

UNIFIED FACILITIES CRITERIA (UFC)

AIR TRAFFIC CONTROL and AIR OPERATIONS FACILITIES



APPROVED FOR PUBLIC RELEASE; DISTRIBUTION UNLIMITED

UNIFIED FACILITIES CRITERIA (UFC)

**AIR TRAFFIC CONTROL and
AIR OPERATIONS FACILITIES**

Any copyrighted material included in this UFC is identified at its point of use.
Use of the copyrighted material apart from this UFC must have the permission of the
copyright holder.

U.S. ARMY CORPS OF ENGINEERS

NAVAL FACILITIES ENGINEERING COMMAND (Preparing Activity)

AIR FORCE CIVIL ENGINEER CENTER

Record of Changes (changes are indicated by \1\ ... /1/)

Change No.	Date	Location
<u>1</u>	<u>December 2017</u>	<u>Revised UFC Summary Sheet and Para. 1-3 Army Applicability</u>
<u>2</u>	<u>June 2019</u>	<u>Changed references to USACE Mobile District to Savannah District on Pages 2, 3, and 5</u>

This UFC supersedes UFC 4-133-01N, dated July 2007.

FOREWORD

The Unified Facilities Criteria (UFC) system is prescribed by MIL-STD 3007 and provides planning, design, construction, sustainment, restoration, and modernization criteria, and applies to the Military Departments, the Defense Agencies, and the DoD Field Activities in accordance with [USD \(AT&L\) Memorandum](#) dated 29 May 2002. UFC will be used for all DoD projects and work for other customers where appropriate. All construction outside of the United States is also governed by Status of Forces Agreements (SOFA), Host Nation Funded Construction Agreements (HNFA), and in some instances, Bilateral Infrastructure Agreements (BIA.) Therefore, the acquisition team must ensure compliance with the more stringent of the UFC, the SOFA, the HNFA, and the BIA, as applicable.

UFC are living documents and will be periodically reviewed, updated, and made available to users as part of the Services' responsibility for providing technical criteria for military construction. Headquarters, U.S. Army Corps of Engineers (HQUSACE), Naval Facilities Engineering Command (NAVFAC), and Air Force Civil Engineer Center (AFCEC) are responsible for administration of the UFC system. Defense agencies should contact the preparing service for document interpretation and improvements. Technical content of UFC is the responsibility of the cognizant DoD working group. Recommended changes with supporting rationale should be sent to the respective service proponent office by the following electronic form: [Criteria Change Request](#). The form is also accessible from the Internet sites listed below.

UFC are effective upon issuance and are distributed only in electronic media from the following source:

- Whole Building Design Guide web site <http://dod.wbdg.org/>.

Hard copies of UFC printed from electronic media should be checked against the current electronic version prior to use to ensure that they are current.

AUTHORIZED BY:



JAMES C. DALTON, P.E.
Chief, Engineering and Construction
U.S. Army Corps of Engineers



JOSEPH E. GOTT, P.E.
Chief Engineer
Naval Facilities Engineering Command



EDWIN H. OSHIBA, SES, DAF
Deputy Director of Civil Engineers
DCS/Logistics, Engineering &
Force Protection



MICHAEL McANDREW
DASD (Facilities Investment and Management)
Office of the Assistant Secretary of Defense
(Energy, Installations, and Environment)

UNIFIED FACILITIES CRITERIA (UFC) NEW SUMMARY SHEET

Document: UFC 4-133-01, *Air Traffic Control and Air Operations Facilities*

Superseding: *UFC 4-133-01N, Navy Air Traffic Control Facilities, 30 July 2007; UFC 4-141-10N, Design Aviation Support Facilities \1\ Section 6 and Section 8 and all other content relating to facility types in this UFC 4-133-01 /1/, United States Air Force Design Guide for Air Traffic Control Towers and Radar Approach Control Facilities, 15 November 2001.*

Description:

UFC 4-133-01 provides requirements for evaluating, planning, programming, and designing Air Traffic Control (ATC) and Air Operations Facilities. This UFC contains guidance for Army, Navy and Air Force planners, engineers, and architects on the planning, engineering, and design of Air Traffic Control Towers (ATCT), Radar Approach Control Facilities (ARAC/RATCF/RAPCON), and Air Operations Buildings (AOB). This UFC is intended as a source of basic architectural and engineering information for all individuals involved in the planning, design, or evaluation of ATC and Air Operations Facilities.

Reasons for Document:

This UFC was developed to provide design requirements to accomplish the following:

- Assist planners in understanding the facility requirements to ensure accurate space programs and budgets,
- Provide architects, engineers and construction surveillance personnel with the essential, minimum requirements for the design and construction of Air Traffic Control and Air Operations Facilities.

Impact:

The following will result from the publication of this UFC:

- There are negligible cost impacts; however, a greater degree of standardization among the Service Branches will result.

\1\ Change 1:

- UFC Summary Sheet. **Superseding** paragraph revised to reflect that this UFC supersedes only certain content of UFC 4-141-10N.
- Para 1-3. Revised to clarify required coordination with respective Army Centers of Aviation Standardization and Expertise and change in availability of definitive designs./1/

Change 2:

- Paragraph 1-3. Changed "Mobile District Center of Standardization of Army Vertical Aviation Facilities (CESAM-AVN-COS-V)" to "Savannah District Center of Standardization for Air Traffic Control/Air Operations Facilities (CESAS-ATCT-COS)"
- Paragraph 1-6. Changed "Aviation Center of Standardization-Vertical (CESAM-AVN-COS-V), Mobile District" to " Air Traffic Control/Air Operations Facilities Center of Standardization (CESAS-ATCT-COS), Savannah District,"
- Paragraph 2-1. Changed "AVN COS-V" to "ATCT-COS" /2/

Unification Issues

The following table identifies items that are not unified among the services:

Section	Topic	Issue
3-9.1	Physical Security General Requirements	The Navy provides additional operational security requirements for ATC facilities.
4-1.2.20	Cab Consoles	Cab consoles are procured differently by each service.
4-1.7.7	Airfield Lighting Control Panel	Each Service branch has unique requirements for the Airfield Lighting Control Panel based on operational standards and interaction with established ATC systems.
4-2.7.7.4	Back-Up Radio Poles and Communications Antennas	The Air Force maintains a requirement for poles for mounting back-up radio antennas.
4-2.7.8.1	Operations/IFR Lighting	The Navy requires colored lights to provide continuity between shore and shipboard operations. The Army and Air Force do not have a requirement for colored lights in the Operations/IFR Room.

This Page Intentionally Left Blank

TABLE OF CONTENTS

CHAPTER 1 INTRODUCTION	1
1-1 BACKGROUND	1
1-2 PURPOSE AND SCOPE.....	1
1-3 APPLICABILITY.	2
1-4 GENERAL BUILDING REQUIREMENTS.....	2
1-5 FACILITY PROJECT TEAM.....	2
1-6 PROGRAM AUTHORITIES.....	3
1-7 APPENDICES.....	3
CHAPTER 2 PLANNING AND LAYOUT.....	5
2-1 SPACE CRITERIA.....	5
2-2 COLLATERAL EQUIPMENT.....	5
2-3 PROJECT PHASING AND COORDINATION.....	5
2-4 FACILITY TYPES.....	6
2-5 COMBINING AIR TRAFFIC CONTROL AND AIR OPERATIONS FACILITY TYPES.....	33
2-6 SITE SELECTION AND APPROVAL PROCESS.....	33
CHAPTER 3 GENERAL REQUIREMENTS.....	37
3-1 AIRFIELD SAFETY.....	37
3-2 ARCHITECTURAL.....	37
3-3 STRUCTURAL.....	40
3-4 MECHANICAL.....	40
3-5 PLUMBING.....	45
3-6 FIRE PROTECTION AND LIFE SAFETY.....	45
3-7 ELECTRICAL.....	48
3-8 TELECOMMUNICATIONS.....	55
3-9 PHYSICAL SECURITY.....	58
3-10 SITE WORK.....	59
3-11 SAFETY AND HEALTH.....	60

CHAPTER 4 SPECIAL DESIGN REQUIREMENTS.....	62
4-1 AIR TRAFFIC CONTROL TOWER (ATCT).....	62
4-2 RADAR APPROACH CONTROL FACILITY (RACF).....	91
4-3 AIR OPERATIONS BUILDING (AOB).....	104
CHAPTER 5 FUNCTIONAL DATA SHEETS.....	110
5-1 INTRODUCTION.....	110
APPENDIX A REFERENCES.....	187
A-1 GOVERNMENT PUBLICATIONS.....	187
A-2 NON-GOVERNMENT PUBLICATIONS.....	192
APPENDIX B BEST PRACTICES.....	193
B-1 DEVELOPMENT OF REQUIRED BUILDING AREA AND LAYOUT.....	193
B-2 ATCT HEIGHT DETERMINATION.....	193
B-3 USE OF DIMENSIONS ON FLOOR PLAN DIAGRAMS.....	193
B-4 PROJECT EXPERIENCE.....	193
B-5 AT/FP REQUIREMENTS.....	193
B-6 TEMPORARY MOBILE ATCT.....	193
B-7 ACCESSIBILITY VS. FUNCTIONALITY.....	193
B-8 ELEVATOR ROOM.....	193
B-9 EXTERIOR CATWALK ACCESS.....	193
B-10 CATWALK SCAFFOLD.....	194
B-11 EXTERIOR OBSERVATION AREA GRATES.....	194
B-12 OVERALL TOWER SHAFT.....	194
B-13 ATCT POWER SHADES.....	194
B-14 CABLE TRAY LAYOUT/ROUTING.....	194
B-15 ATCT CABLE LENGTH.....	194
B-16 DESIGN SPECIAL LOADS.....	194
B-17 LANDSCAPING AND BIRD ISSUES.....	195
B-18 FOAM INSULATION.....	195
B-19 PARKING.....	195
B-20 WORK NOT INCLUDED IN CONSTRUCTION CONTRACT.....	195
APPENDIX C OUTLINE OF TYPICAL SITE SELECTION PROCESS.....	197
APPENDIX D GLOSSARY.....	199

FIGURES

Figure 2-1 ATCT Functional Shaft Vertical Adjacency Diagram.....	14
Figure 2-2 ATCT Control Cab Notional Floor Plan Diagram.....	15
Figure 2-3 ATCT Control Cab Section Diagram.....	16
Figure 2-4 ATCT Non-Functional Shaft with Support Building	17
Figure 2-5 ATCT Functional Shaft without Support Building.....	18
Figure 2-6 ATCT Functional Shaft with Support Building	19
Figure 2-7 ATCT Functional Shaft - Standalone	20
Figure 2-8 RACF Adjacency Diagram.....	27
Figure 2-9 RACF IFR Room	28
Figure 2-10 RACF IFR Equipment Room.....	28
Figure 2-11 AOB Adjacency Diagram.....	32
Figure 4-1 Electronic Equipment Room Clearance Detail.....	64
Figure 4-2 Plan Detail at Control Cab Window Mullion and Structural Column (Army and Air Force only)	73
Figure 4-3 Plan Detail at Control Cab Window Mullion and Structural Column (Navy) ..	73
Figure 4-4 Ceiling Support Plate Section Detail.....	78

TABLES

Table 2-1 ATCT Cab Controller and Space Allowances	8
Table 2-2 ATCT Functional Program Areas	9
Table 2-3 RACF Functional Program Areas	22
Table 2-4 Airfield Operations Building Functional Program Areas	30
Table 4-1 Design Live Loads	76
Table 4-2 Design Live Loads	94
Table 5-1.1 ATCT – Main Entrance Lobby/Vestibule	111
Table 5-1.2 ATCT – Elevator and Elevator Lobby	112
Table 5-1.3 ATCT – Elevator Machine Room	112
Table 5-1.4 ATCT – Tower Shaft Mechanical Room	114
Table 5-1.5 ATCT – Tower Shaft Electrical Room	115
Table 5-1.6 ATCT – Telecommunications Room	116
Table 5-1.7 ATCT – Fire Pump Room	117
Table 5-1.8 ATCT – ATCT Simulator Room	118
Table 5-1.9 ATCT – Administration Area	119
Table 5-1.10 ATCT – Chief Controller's Office, Chief AIC Office, Chief GCA Office	120
Table 5-1.11 ATCT – Training Room	121
Table 5-1.12 ATCT – Toilet Rooms	122
Table 5-1.13 ATCT – Janitor Closet	123
Table 5-1.14 ATCT – Stairwell	124
Table 5-1.15 ATCT – Lower Electronic Equipment Room	124
Table 5-1.16 ATCT – Upper Electronic Equipment Room	126
Table 5-1.17 ATCT – UPS Room	127
Table 5-1.18 ATCT – Ready/Break Room	128
Table 5-1.19 ATCT – Control Cab Mechanical Room	129
Table 5-1.20 ATCT – Control Cab Electrical/Communications Room	130
Table 5-1.21 ATCT – Control Cab	131
Table 5-1.22 ATCT – Electronic Equipment Room for VCSS	131
Table 5-1.23 ATCT – Ground Controlled Approach	133
Table 5-1.24 ATCT – Airspace Information Center	134
Table 5-1.25 ATCT – ATC Equipment Maintenance Building	135
Table 5-2.1 RACF – Lobby/Entry Vestibule	135
Table 5-2.2 RACF – ATC Administration Area	137
Table 5-2.3 RACF – Private Offices	138
Table 5-2.4 RACF – Toilet Rooms with Lockers and Showers	139
Table 5-2.5 RACF – Janitor Closet	140
Table 5-2.6 RACF – Mechanical Room	141
Table 5-2.7 RACF – Electrical Room	142
Table 5-2.8 RACF – Telecommunications Room	143
Table 5-2.9 RACF – TERPS/DSS Office	144
Table 5-2.10 RACF – Operations/Instrument Flight Rules (IFR) Room	145
Table 5-2.11 RACF – Radar Simulator Room	147
Table 5-2.12 RACF – ATCT Simulator Room	148
Table 5-2.13 RACF – Training Room	149
Table 5-2.14 RACF – Briefing/Conference Room	150
Table 5-2.15 RACF – IFR Equipment Room	151

Table 5-2.16 RACF – UPS Room.....	151
Table 5-2.17 RACF – Storage Room.....	153
Table 5-2.18 RACF – Flight Planning Room	154
Table 5-2.19 RACF – Pilot Flight Planning Room.....	155
Table 5-2.20 RACF – ATC Equipment Maintenance Administration Area	156
Table 5-2.21 RACF – ATC Equipment Maintenance Area	157
Table 5-2.22 RACF – Break Room	158
Table 5-2.23 RACF – 2M (Micro Miniature) Electronic Repair Room.....	159
Table 5-3.1 AOB – Lobby/Entry Vestibule	160
Table 5-3.2 AOB – HQ / Command Suite - Reception Area	161
Table 5-3.3 AOB – HQ / Command Suite - Private Offices.....	162
Table 5-3.4 AOB – Air Operations Duty Officer.....	163
Table 5-3.5 AOB – Operations - Airfield Management/Flight Planning.....	164
Table 5-3.6 AOB – Operations – Pilot Flight Planning Room	165
Table 5-3.7 AOB – Operations – Weather Station.....	166
Table 5-3.8 AOB – Operations – Pilot Ready Room	167
Table 5-3.9 AOB – Airfield Services – Open Office Area	168
Table 5-3.10 AOB – Airfield Services – Printer/Copier Station.....	169
Table 5-3.11 AOB – Non-Sensitive Secure Storage Room.....	170
Table 5-3.12 AOB – General Purpose Storage Room	171
Table 5-3.13 AOB – File Storage Area	172
Table 5-3.14 AOB – ATC Equipment Maintenance Administration Area	173
Table 5-3.15 AOB – ATC Equipment Maintenance Area	174
Table 5-3.16 AOB – Break Area	175
Table 5-3.17 AOB – Multipurpose Room	175
Table 5-3.18 AOB – Male and Female Toilet Rooms.....	177
Table 5-3.19 AOB – Janitor Closet.....	178
Table 5-3.20 AOB – Mechanical Room	179
Table 5-3.21 AOB – Electrical Room	180
Table 5-3.22 AOB – Telecommunications Room.....	181
Table 5-3.23 AOB – SIPR Room	182
Table 5-3.24 AOB – Outside Covered Storage Area	183
Table 5-3.25 AOB – Transient Passenger Services.....	184
Table 5-3.26 AOB – VIP Passenger Services.....	185

This Page Intentionally Left Blank

CHAPTER 1 INTRODUCTION

1-1 BACKGROUND

This Unified Facilities Criteria (UFC), UFC 4-133-01, provides requirements for evaluating, planning, programming, and designing Air Traffic Control (ATC) and Air Operations Facilities. The requirements contained in this UFC apply to Army, Navy, and Air Force facilities unless specifically referenced to a single service. This UFC is not intended as a substitution for thorough review during design by individual Program Managers and Operations Staff in the appropriate service.

The desired goal of this UFC is to maintain consistency in ATC and Air Operations Facility requirements across the Army, Navy and Air Force. This UFC is not intended as an operational manual.

Each service has unique requirements to fulfill specific missions. This document will highlight any key differences that impact the overall facility program, layout and design. Where one Service's criteria vary from the other Services' criteria, it is noted in the text.

1-2 PURPOSE AND SCOPE.

This UFC contains guidance for Army, Navy and Air Force planners, engineers, and architects on the planning, engineering, and design of ATC and Air Operations Facilities, which include three facility types:

- Air Traffic Control Tower (ATCT) – Houses equipment and personnel for control of aircraft approaching, departing, and transiting the terminal area or airport and aircraft and vehicular movement on the runways, taxiways and all other movement areas.
- Radar Approach Control Facility (RACF), referred to as the Army Radar Approach Control Facility (ARAC); the Navy Radar Air Traffic Control Facility (RATCF); or the Air Force Radar Approach Control Facility (RAPCON) – Enables the radar branch to provide radar ATC services to instrument flight rules (IFR) and visual flight rules (VFR) air traffic within assigned airspace.
- Air Operations Building (AOB), referred to as the Navy Air Operations Building; the Air Force Airfield Management Operations (AMOPS) Building; or the Army Airfield Headquarters Building/Airfield Operations Facility - Houses the central command, control, services, and management center of an air installation complex. It provides the management center for flight operations, services, and movement control for the entire air installation complex.

1-3 APPLICABILITY.

This UFC is intended as a source of basic architectural and engineering information for all individuals involved in the planning, design, construction or evaluation of ATC and Air Operations Facilities. Architects and engineers (A/Es) that provide design services will use this UFC under the direction of the Service design agencies. Installation and facility planning personnel will use this UFC, in conjunction with other required planning documents, for programming new or replacement facilities, pre-design planning, or assessing the extent of improvements required in an existing ATC or Air Operations Facility in order to achieve the standard established herein.

Refer to UFC 3-260-01, Sec. 1-4, for additional applicability description.

For more information, refer to the following **Service-specific** governing documents:

- **Army:** \1\ This UFC must be used in coordination with the \2\Savannah District Center of Standardization for Air Traffic Control/Air Operations Facilities (CESAS-ATCT-COS)/2/, and the Omaha District, Army Mandatory Center of Expertise for Horizontal Aviation (CENWO-MCX-Horizontal AVN) by authorities granted under ER 1110-345-100 and ER 1110-3-109. /1/
- **Navy:** This UFC is the primary guidance to be used in conjunction with Facility Requirements Documents (FRD), Facility Requirements Supplements (FRS), Intrusion Detection Systems Engineering Plans (IDSEP), Base Exterior Architecture Plans (BEAP), and other DoD and Department of Transportation (DOT) material for the planning and construction of ATCFs and the preparation of DD 1391 MILCON and Step II Special Project Submissions.
- **Air Force:** This UFC must be used in coordination with AF Project Manager Guide for Construction and AFMAN 32-1084, *Facilities Requirements*.

1-4 GENERAL BUILDING REQUIREMENTS.

UFC 1-200-01, "General Building Requirements", provides applicability of model building codes and government-unique criteria for typical design disciplines and building systems, as well as for accessibility, antiterrorism, security, sustainability, and safety. Use this UFC in addition to UFC 1-200-01 and the UFCs and government criteria referenced therein, including the core UFCs listed in UFC 1-200-01.

1-5 FACILITY PROJECT TEAM.

The planning and design team for ATC and Air Operations Facilities must include the standard architectural and engineering (including civil, structural, MEP, and fire protection) disciplines along with the following representatives:

- Airfield or Heliport Operations
- Airfield or Heliport Maintenance Operations
- Environmental Quality and Protection

- Safety
- Fire Emergency Services
- Facility Maintenance
- Energy Management
- Flightline and AT/FP Security
- Space and Naval Warfare Systems Command (SPAWAR) - Navy only

1-6 PROGRAM AUTHORITIES.

Prior to project development, confirm the acquisition methodology and coordinate facility requirements with the appropriate Service. The functional proponent to justify the need, scope (size), and utilization of an ATC or Air Operations Facility is described below. Engineers and planners should assist operations personnel with the planning and programming, definition and scope, site selection, and design of the facility. The functional proponents for each Service are:

- **Army:** Coordinated effort of Air Traffic Services Command (ATSCOM), U.S. Army Aeronautical Services Agency (USAAA), the ²Air Traffic Control/Air Operations Facilities Center of Standardization (CESAS-ATCT-COS), Savannah District,² and the Transportation Systems Center (TSC), Omaha District.
- **Navy and Marine Corps:** Coordinated effort of the Station, SPAWAR, NAVAIR and NAVFAC
- **Air Force:** Air Force Final Authority A30-BAA, HQ AFFSA (operations) and AFCEC (technical).

1-7 APPENDICES.

Appendix A contains a list of references used in this document. The publication date of the code or standard is not included in this document. In general, the latest available issuance of the reference is used.

Appendix B contains a list of background information, “lessons learned,” and other current, good design practices. The designer is expected to review and interpret this guidance and apply the information according to the needs of the project.

Appendix C contains an outline of the Site Selection Process.

Appendix D contains acronyms, abbreviations, and terms.

This Page Intentionally Left Blank

CHAPTER 2 PLANNING AND LAYOUT

This chapter describes the technical requirements that should be addressed during the planning and layout phase in order to understand the unique requirements of Air Traffic Control (ATC) and Air Operations Facilities.

2-1 SPACE CRITERIA.

ATC and Air Operations Facility space needs are site and mission specific and must be individually programmed based on a facility study. Space program development guidance is provided in the following documents:

- **Army:** Actual size must be determined from the definitive standard design and criteria documents in conjunction with unique site requirements shown in the Design-Build Request for Proposals (DB RFP) documents for new ATCFs. Space modules, criteria, or components of the Airfield HQ/ATC Facility must be used to develop space allowances and/or requirements before consideration for development of unique or specialized space allowances from those set forth in this definitive standard design. When space standards and criteria and/or components are not used, the Functional Proponent, in accordance with the Aviation FDT, AVN \2\ATCT-COS/2/ (buildings), and AVN COS-H (siting), will review and validate functional or operational requirements prior to the development of any unique or specialized space allowance(s) and before incorporating into a project programming document or facility design.
- **Navy:** Actual size must be determined during the planning phase using UFC 2-000-05N, *Facility Planning Criteria for Navy and Marine Corps Shore Installations* and UFC 3-101-01, *Architecture*. Consult SPAWAR for the space requirements of the required ATC equipment.
- **Air Force:** Actual size must be determined during the planning process using AFMAN 32-1084, *Facility Requirements*.

Certain spaces are not defined specifically in space programming criteria, such as the Control Cab and Simulator Classroom. These spaces should be considered and added to the space criteria during the planning/DD 1391 development phase.

2-2 COLLATERAL EQUIPMENT.

ESD workbenches, storage cabinets, and shelving are usually procured with the rest of the facility furniture. The work benches, storage cabinets, and shelving are not “built in” during construction. Special ESD chairs are also required.

2-3 PROJECT PHASING AND COORDINATION.

If continuous operations are required, then ensure that project construction phasing does not interrupt ATC operations.

FAA and ATC equipment will need to be relocated from existing facilities, or procured and installed in a new ATC facility. Coordinate requirements and appropriate funding during the planning phase. Refer to Appendix B-20 of this UFC for more information.

2-4 FACILITY TYPES.

Design the ATC and Air Operations Facilities to provide space and equipment for the specific functions required by the project mission. In general, there are two (2) types of ATC Facilities and one (1) type of Air Operations Facility:

1. Air Traffic Control Tower (ATCT)
2. Radar Approach Control Facility (RACF) and
3. Air Operations Building (AOB)

2-4.1 Air Traffic Control Tower (ATCT).

2-4.1.1 Function

The Air Traffic Control Tower (ATCT) houses equipment and personnel for control of aircraft approaching and departing the terminal area and aircraft and vehicular movement on the runways, taxiways, and all other movement areas. It is an elevated structure having an unobstructed line-of-sight to the airfield approach areas, runways, taxiways, aircraft parking areas, and all other operational areas over which aircraft movements must be controlled. The ATCT may be an independent facility or combined with a Radar Approach Control Facility (RACF) or an Airfield Operations Building (AOB). If at all possible, the control tower should be an integral facility with the RACF, thus providing a complete, integrated air traffic control facility.

The ATCT is the nerve center for an air installation complex. All air movement within the Class D airspace and all ground movement are controlled via the ATCT when operational. In some locations, control is relinquished as an advisory service to Flight Operations during extended hours of operation. All aviation electronics (e.g. radios), navigational aids, and landing/approach systems are controlled and operated by ATC personnel. Hence, redundant capabilities in controlling lighting, communications, and data must exist at both the ATCT and Flight Operations. During emergency conditions, (e.g., severe weather), ATC activities may displace to Flight Operations when occupying a tall, narrow building becomes hazardous to ATC personnel.

2-4.1.2 Tower Location and Height.

Each Service branch maintains a Site Selection process that establishes overall Tower location and height. Siting is dependent on a Siting Report. Refer to Section 2-6 for more information.

2-4.1.3 Space Allowance.

Each Service branch maintains a program approval process that establishes overall ATCT size.

- **Army:** The tower gross square foot (GSF) area is a function of the required height for observation of aircraft. This is validated by G-3/5/7 (USAASA). The tower can be a single structure composed of a Control Cab and the tower vertical shaft, which accommodates the structure, functional areas, and provides a code compliant stairwell and elevator. In addition, a tower can be a single structure co-located with another facility structure, but separated seismically for force protection measures.
- **Navy:** The minimum installation is a basic tower containing an entrance level, five (5) intermediate levels, and the Control Cab. Towers of increased height can be provided by adding incremental levels. Cab dimensions are determined during the design phase. Reference UFC 2-000-05N.
- **Air Force:** Refer to Air Force Manual (AFMAN) 32-1084. Space requirements are generally dictated by the site survey and Statement of Intent (SOI) that defines some site specific design parameters. AF Operations (AOF, CCTLR, and AFFSA) will determine the Control Cab occupancy in the site survey.

Table 2-1 outlines the various ATCT Cab level controller and space allowances, either in net square feet (NSF) or gross square feet (GSF). The number of positions and total square footage for each service are based on current average standards. Additional Cab area may be required based on higher controller levels.

Table 2-1 ATCT Cab Controller and Space Allowances

ATCT Service Criteria	Typical ATC Controller Positions ¹	Cab Area (SF)	
Army			
Standard Cab 3 positions and 1 supervisor	4	600 Max NSF ²	Based on AR 420-01 and TC 3-04.81
Navy			
Standard Small Cab 2 positions and 1 supervisor	3	370 GSF ³	Based on NAVAIR 80-T-114
Standard Medium Activity Cab 3 positions and 1 supervisor	4	500 GSF	
Standard Large Cab 4 positions and 1 supervisor	5	620 GSF	
Air Force			
Standard Cab 3 positions and 2 supervisors (including SOF – Supervisor of Flying)	5	540 NSF + 64 NSF for each additional position	Based on AFMAN 32-1084

¹ Positions include space for trainees. Additional special positions may be required based on survey results.

² NSF = Net Square Feet

³ GSF = Gross Square Feet

2-4.1.4 Functional Program Areas.

Typical functional program areas are listed and described briefly in Table 2-2 and described in greater detail in Chapter 5.

Note: Not all ATCT's contain all of the areas listed in the table. The functional areas required are dependent on operational requirements, and the functions required are determined by the user during the planning/DD 1391 development phase.

Table 2-2 ATCT Functional Program Areas

Functional Program Area	Description
Main Entrance Lobby/Vestibule (Table 5-1.1)	Main entrance to the ATCT. Include vestibule in cold weather climates.
Elevator and Elevator Lobby (Table 5-1.2)	One (1) elevator must be provided to service the ATCT. Elevator service is not required to serve the Control Cab and the floor immediately below the Control Cab. However, if a hydraulic elevator is used, the elevator can serve all floors including the one immediately below the Control Cab.
Elevator Machine Room (Table 5-1.3)	A room housing elevator machine equipment.
Tower Shaft Mechanical Room (Table 5-1.4)	A room housing mechanical equipment servicing the Tower Segment with a lockable door.
Tower Shaft Electrical Room (Table 5-1.5)	A room housing electrical equipment servicing the Tower Segment with a lockable door.
Telecommunications Room (Table 5-1.6)	Telephone / Data Communications Frame Room housing the communications distribution plant.
Fire Pump Room (Table 5-1.7)	A room housing the fire pump.
ATCT Simulator Room (Table 5-1.8)	A Simulator Room may be required in the ATCT or the RACF. Refer to description of Simulator Room in <u>Table 2-3</u> .
Administration Area (Table 5-1.9)	An area for the Facility Administrative Work Space.
Private Offices	Provide private offices for the following:

Functional Program Area	Description
(Table 5-1.10)	1. An office for the Chief Controller with a lockable door. The Chief Controller controls all operations of the ATCT and reports back to the AOF/CC. All personnel within the ATCT report to the Chief Controller.
	2. An office for the Chief of Airspace Information Center (Army only)
	3. An office for the Chief of Ground Controlled Approach (Army only)
Training Room (Table 5-1.11)	A room for mandatory training with a lockable door. May be combined with Break Room for space and budgetary constraints.
Toilet Rooms (Table 5-1.12)	Provide a minimum of two (2) toilet rooms, both unisex, one near ground level and one on the level directly below the Control Cab. If the ATCT is attached to a support building that has toilet rooms, then the First and Second floors of the Tower are not required to have a toilet room for those floors. Toilet rooms are only required for the Third floor and above.
Janitor Closet (Table 5-1.13)	A room for janitorial supplies and equipment.
Stairwell (Table 5-1.14)	Pressurized fire-rated stairwell providing emergency egress from the floor below the Control Cab to the ground floor
Lower Electronic Equipment Room (Table 5-1.15)	A room housing ATC electronic equipment with a lockable door. Divide electronic equipment room into two rooms on different floors only if equipment will not fit on one floor due to Occupational Safety and Health Administration (OSHA) standards (e.g. equipment rack spacing). Some stand-alone ATCTs could require three equipment rooms on different floors to accommodate additional equipment (such as a voice switch, recorder, etc.)

Functional Program Area	Description
Upper Electronic Equipment Room (Table 5-1.16)	Preferred location for communication equipment, equipment with antennas, and back-up radio systems.
UPS Room (Table 5-1.17)	A room housing batteries and the UPS system, with a lockable door. May be combined with the ATCT Electronic Equipment Room.
Ready/Break Room (Table 5-1.18)	A room with a small kitchenette and seating for mandatory controller breaks on a separate level from the ATCT Control Cab.
Control Cab Mechanical Room (Table 5-1.19)	A mechanical room providing HVAC service for the ATCT Control Cab separately.
Control Cab Electrical/ Telecommunications Room (Table 5-1.20)	A room housing electrical power and telecommunications equipment for the Control Cab.
Control Cab (Table 5-1.21)	A room with windows on all sides with minimal window framing to maximize view of the airfield.
Electronic Equipment Room (Table 5-1.22)	Additional room housing additional ATC Electronic Equipment, such as the Voice Communications Switching System (VCSS).
Catwalk	An exterior platform surrounding the Control Cab, providing exterior access for cleaning the Cab glass.
Mechanical Chase	A fire rated chase, open from the ground floor to the concrete sub-floor of the ATCT Cab that serves as a pathway for HVAC and plumbing utilities from the Tower Shaft Mechanical Room to the ATCT Mechanical Room.
Vertical Cable Chase	A fire rated chase, open from the ground floor to the concrete sub-floor of the ATCT Cab that serves as a pathway for communications cables from the first floor Telecommunications Room to the Lower Equipment Room, Upper Equipment Room, and the Control Cab.

Functional Program Area	Description
Antenna Cable Chase	Ducts or conduits located within or adjacent to the Control Cab structural columns that serve as pathways for antenna cables from the Equipment Room containing radios to the ATCT Roof.
Ground Controlled Approach (Table 5-1.23)	An office-type open work area for Ground Controlled Approach operations.
Airspace Information Center (Table 5-1.24)	An office-type open work area for Airspace Information Center operations.
ATC Equipment Maintenance (Table 5-1.25)	A building/room for ATC electronic equipment maintenance, including an area for soldering and storage, when an ATCT is located remotely from the Airfield Operations Building.
Mechanical Yard	A screened maintenance yard must be provided for the chiller, back-up generator fuel tank, transformer, etc. In cold-weather climates, the generator may be located in an enclosed generator room. Coordinate with AT/FP requirements.

2-4.1.5 Functional vs. Non-Functional Tower Shaft.

ATCTs may have a functional or a non-functional tower shaft supporting the Control Cab. The key programmatic differences between a functional and a non-functional tower shaft include the following:

- Functional Tower Shaft: Typically pertains to low and intermediate activity ATCTs where operations support functions can be located on most floors in the tower shaft. This eliminates the need for an administrative support building.
- Non-functional Tower Shaft: Typically pertains to major activity ATCTs where operations support functions cannot fill up all the floors in the tower shaft. The shaft includes only unoccupied spaces (i.e. egress stair, elevator and service shafts, etc.) to reduce the floor footprint for cost efficiency. Two to three floors immediately below the cab can be used for administrative support and equipment spaces (these floors can have a wider footprint).

In either case, the preferred layout for the tower shaft is rectangular or square to maximize the efficiency of the layout of the internal spaces.

2-4.1.6 Adjacencies and Layout.

Figure 2-1 represents the vertical adjacencies in an ATCT. This diagram does not convey a building shape, but represents the required adjacencies in a typical ATCT. Figures 2-2 and 2-3 represent a notional Control Cab plan and Section Diagram, respectively.

Important adjacency requirements include the following:

- ATC personnel normally request that a bathroom and break room be located on the floor directly below the ATCT Cab.
- The ATCT electronic equipment space(s) must be located on the uppermost available floor(s) below the Ready/Break Room to ensure that RF cable runs and communication signal losses are minimized. The exact arrangement of the electronic equipment will depend on the specific design of the ATCT and will be determined during design.
- Support functions such as training rooms may be housed separately in a RACF or AOB when the facilities are collocated.

Figure 2-1 ATCT Functional Shaft Vertical Adjacency Diagram

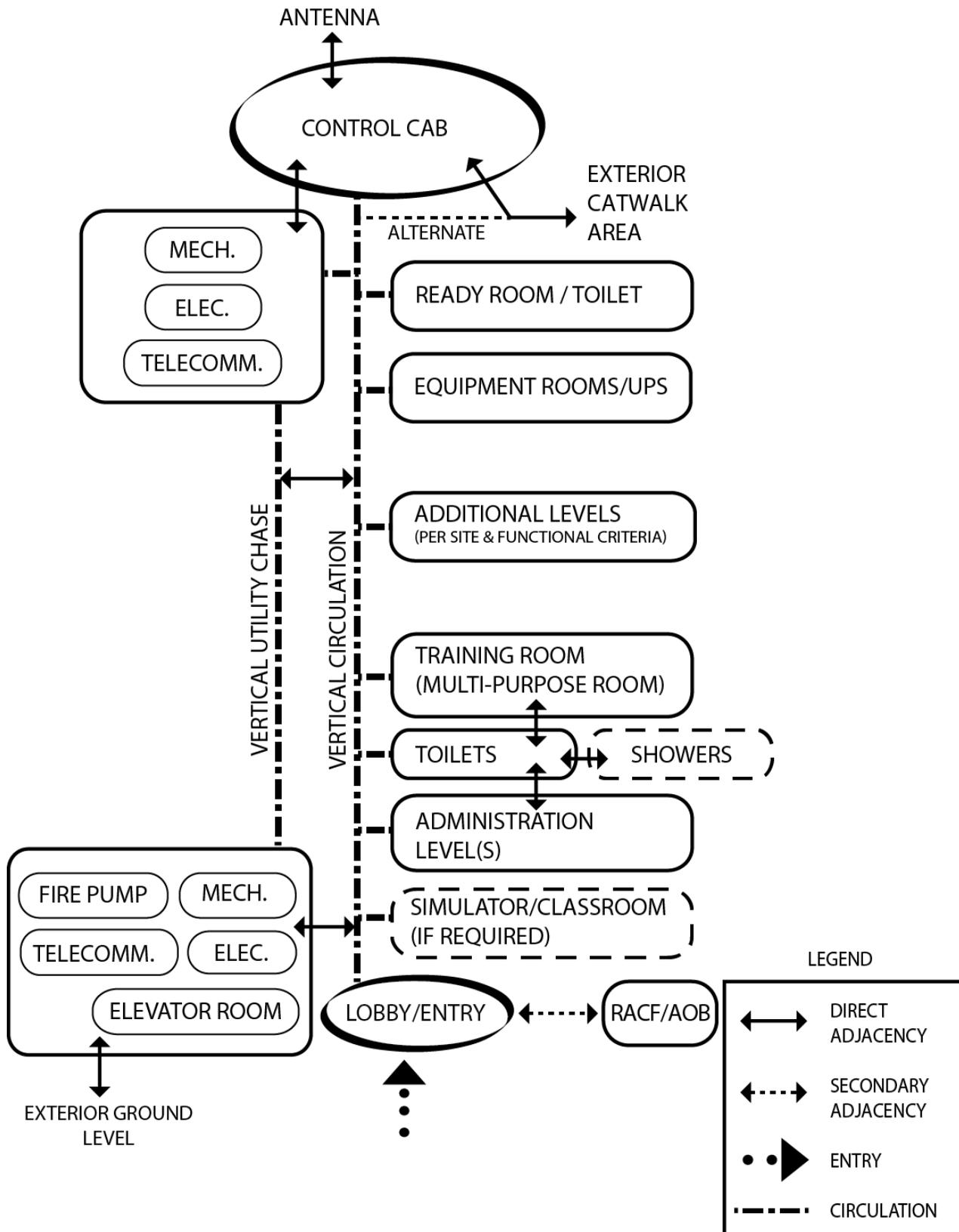

Note: The ATCT Functional Shaft Vertical Adjacency Diagram on the previous page is only illustrative, and is intended to demonstrate typical relationships between programmed spaces. It does not exclude other floor plan geometry, building configurations, or additional spaces required. More refined floor layouts should be developed during the design phase.

Figure 2-2 ATCT Control Cab Notional Floor Plan Diagram

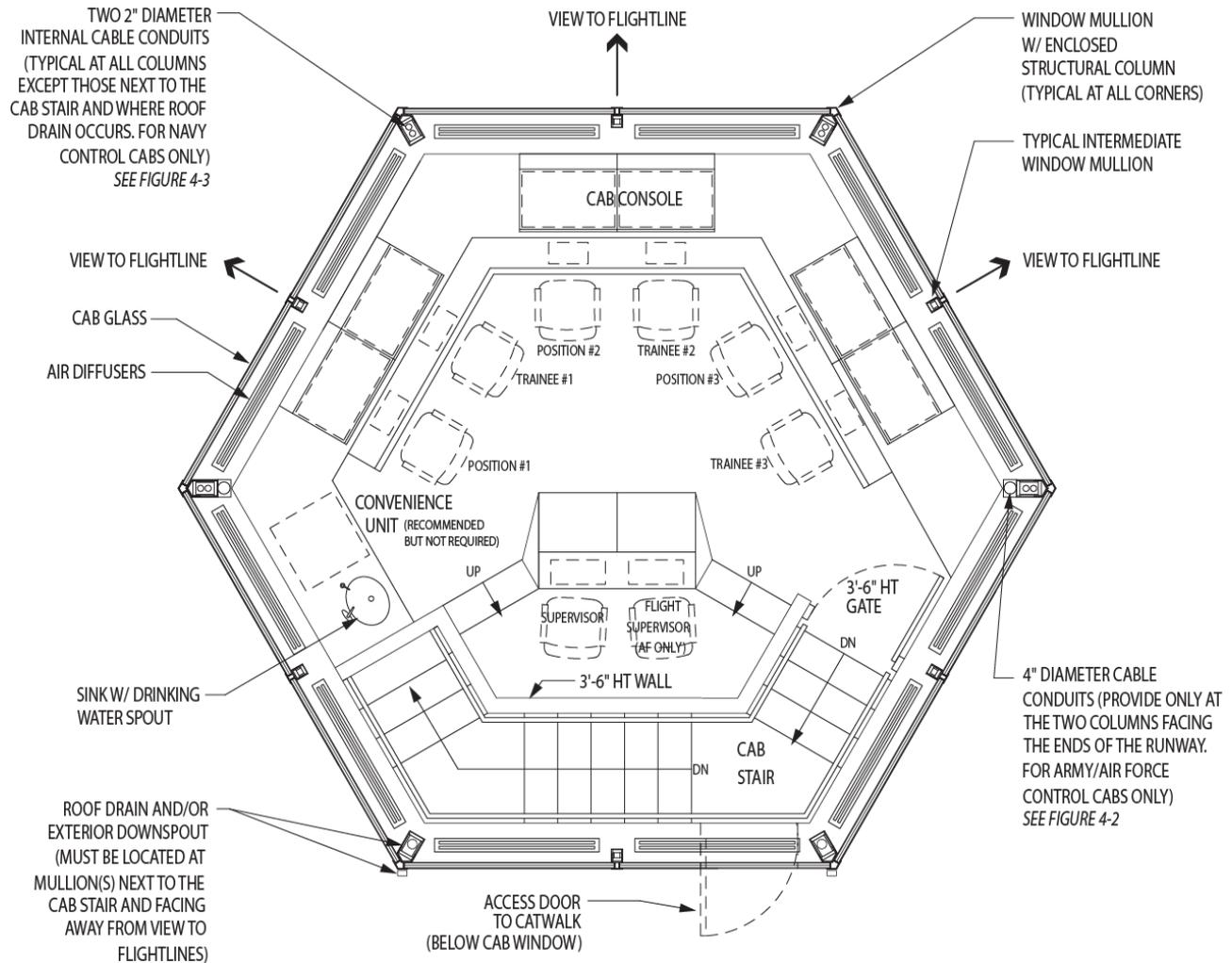

Note: The ATCT Control Cab notional floor plan on this page is diagrammatic and intended to illustrate typical configurations. It does not exclude other tower geometry, Cab configurations, or additional spaces required. More refined floor layouts and should be developed during the design phase.

Figure 2-3 ATCT Control Cab Section Diagram

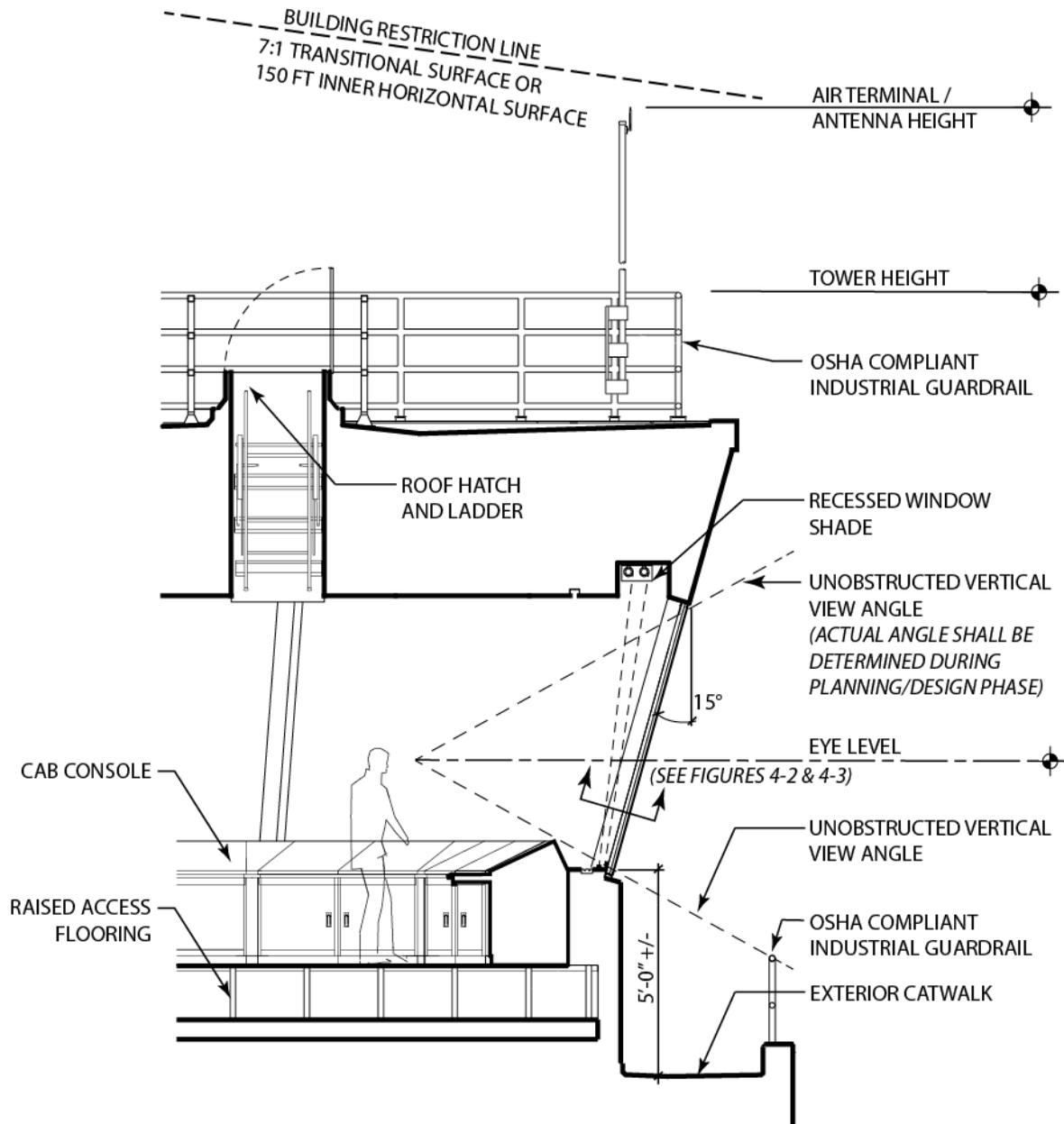

Note: The ATCT Control Cab section is diagrammatic and intended to illustrate typical configurations. It does not exclude other tower geometry and Cab configurations. More refined floor layouts should be developed during the design phase.

Height from exterior catwalk to top of window sill is typical per FAA standards. Maximum distance should allow for simultaneous Control Cab viewing and window washing.

Figure 2-4 ATCT Non-Functional Shaft with Support Building



Figure 2-5 ATCT Functional Shaft without Support Building



Figure 2-6 ATCT Functional Shaft with Support Building



Figure 2-7 ATCT Functional Shaft - Standalone



2-4.2 Radar Approach Control Facility (RACF).

2-4.2.1 Function.

A Radar Approach Control Facility (RACF) controls aircraft by using installed radar to provide ATC services to Instrument Flight Rules (IFR) and Visual Flight Rules (VFR) air traffic within a certain assigned airspace. RACFs offer ATC services to aircraft arriving, departing, or transiting the airspace controlled by the facility.

The RACF contains equipment used for controlling air traffic and is staffed by air traffic controllers and air operations, administrative and maintenance support personnel. The scope of radar services provided will vary according to equipment installed and the delegated airspace. The scope and complexity of the services are the significant design drivers. The RACF contains an IFR control room that includes the radar display consoles and communications control equipment. An adjacent terminal equipment room houses all automation central (or terminal) equipment, maintenance positions and audio/video tape recorders.

Based on current practices and policies, each Service maintains unique names for its Radar Approach Control Facilities as follows:

- **Army:** Army Radar Approach Control (ARAC) facilities are located at U.S. Army installations that use surveillance radar (normally collocated with Precision Approach Radar (PAR) facilities) and air/ground communications equipment. ARAC facilities offer air traffic control services to aircraft arriving, departing, or transiting the airspace controlled by the facility. Service is available to both civil and military airports located within approach control airspace.
- **Navy:** Radar Air Traffic Control Facilities (RATCF) are located at U.S. Navy installations. The ASR, PAR, Precision Approach Landing System (PALS), Transmitting and Receiving Sites, and other NAVAIDS, all of which are remotely located, are monitored and controlled in the RATCF. Local agreements may dictate that an FAA air traffic representative be provided office space in the air traffic control facility. An office for the FAA liaison officer is required at joint-operated Navy/FAA terminal radar approach control (TRACON) facilities.
- **Air Force:** Radar Approach Control (RAPCON) facilities are located at U.S. Air Force installations.

2-4.2.2 Location.

RACFs can be sited anywhere within the range of the radar providing radar assisted approach control. The RACF functions well in a single-story facility, making it a candidate for siting near airfields where building heights are restricted by airport conical or imaginary surfaces.

It is preferable to locate the Radar Approach Control Facility (RACF) adjacent to the Air Traffic Control Tower (ATCT). However, the RACF is not required to be adjacent to the ATCT.

Provide drive-up service access to service entries, including the IFR Equipment Room, the Operations/IFR Room (through the IFR Equipment Room), and the Mechanical Room. Refer to Section 2-2 for more information.

2-4.2.3 Functional Program Areas.

Typical functional program areas are listed and described briefly in Table 2-3 and described in greater detail in Chapter 5.

Note: Not all RACFs contain all of the areas listed in the table. The functional areas required are dependent on operational requirements, and the functions required are determined by the user during the planning/DD 1391 development phase.

Table 2-3 RACF Functional Program Areas

Functional Program Area	Description
Lobby/Entry Vestibule (Table 5-2.1)	Main entrance to the RACF. Include vestibule in cold weather climates.
Administrative Offices (Table 5-2.2)	An open office area with freestanding systems furniture workstations for administrative personnel.
Private Offices (Table 5-2.3)	Provide private offices for the following:
	1. Airfield Operations Flight Commander's Office (AOF/CC). The AOF/CC office may or may not be included in the RACF design. This officer is responsible for the overall management of flight operations, which includes the ATCT, RACF, Airfield Management, and Base Operations. If possible, this office should be located in another facility other than the RACF so that flying customers can meet with them at a facility that is not in a controlled area.
Private Offices (cont'd)	2. Chief Controller. The Chief Controller controls all operations of the RACF and reports back to the AOF/CC. All personnel within the RACF report to the Chief Controller.

Functional Program Area	Description
	<p>3. Chief, Air Traffic Control & Training (Air Force: NCOIC, Air Traffic Control Training). This individual is responsible for keeping all training materials up to date as well as for ensuring the training of new personnel and continuing education of current controllers.</p> <p>4. Chief, Standardization & Evaluation (Air Force: NCOIC, Standardization and Evaluation). This individual maintains the currency of the RACF, ensures compliance with Service standards, and evaluates procedures that are in operation.</p> <p>CBI (Computer-Based Instruction).</p>
Toilet Rooms with Lockers and Showers (Table 5-2.4)	If space and budget allow, there should be toilet rooms available adjacent to the Operations/IFR Room and the Break Room. Toilet rooms for administrative personnel and visitors should be provided in the administrative area.
Janitor (Table 5-2.5)	A separate storage room for janitorial supplies and equipment, located near the toilet rooms.
Mechanical Room (Table 5-2.6)	A room housing mechanical equipment servicing the RACF with a lockable door.
Electrical Room (Table 5-2.7)	A room housing electrical equipment servicing the RACF with a lockable door.
Telecommunications Room (Table 5-2.8)	This room is the first termination point for all copper cabling and fiber optic entering the facility. All incoming lines will be surge-suppressed in this room.

Functional Program Area	Description
Terminal Instrument Procedures (TERPS)/Data System Specialist (DSS) Office (Table 5-2.9)	<p>This area is the largest office requirement in the administrative area. The TERPS office is responsible for actual planning and plotting of approach and procedures, revising procedures that are in place, updating procedures based on new criteria such as airfield mishaps, new aircraft controls, etc.</p> <p>Air Force: TERPS Room is required only when the TERPS function is performed at the unit level. Many MAJCOMS have consolidated TERPS offices to control CONUS locations. The A/E must consult the MAJCOM to confirm the location of TERPS.</p> <p>Navy: TERPS/DSS Office not required.</p>
Operations/Instrument Flight Rules (IFR) Room (Table 5-2.10)	<p>This is the primary functional area of the RACF. This space should be located within the facility and never exit directly to the outside. All radar-controlled approaches are handled from this room.</p>
Radar Simulator Room (Table 5-2.11)	<p>A room housing radar simulators for Standard Terminal Automation Replacement System (STARS) simulators and the IPARTS (PAR Trainer).</p>
ATCT Simulator Room (Table 5-2.12)	<p>A room housing simulators for ATCT simulator operations. The ATCT Simulator Room contains the tower simulator.</p>
Training Room (Table 5-2.13)	<p>A room housing the Computer-Based Instruction (CBI) component of RACF training.</p>
Briefing/Conference Room (Table 5-2.14)	<p>This room should be sized to house the entire RACF shift, plus the AOF/CC and the shift Watch Supervisor. The Briefing Room should be sized to accommodate an adequately-sized conference table.</p>
IFR Equipment Room (Table 5-2.15)	<p>A room housing the communications racks that are the termination points for all lines entering and departing the RACF that provide data to and from the scopes in the Operations/IFR Room.</p>

Functional Program Area	Description
UPS Room (Table 5-2.16)	A room housing the UPS system and its batteries. May be combined with the IFR Equipment Room or the Electrical Room.
Storage Room (Table 5-2.17)	An interior storage area for miscellaneous supplies for the office and operational functions of the RACF.
Flight Planning (Table 5-2.18)	Open office area containing flight dispatch and flight planning operations
Pilot Flight Planning (Table 5-2.19)	Open office area containing flight planning operations
ATC Equipment Maintenance Admin Area (Table 5-2.20)	An open office area for administrative functions required for ATC equipment maintenance.
ATC Equipment Maintenance Area (Table 5-2.21)	An area for ATC equipment maintenance, including space for soldering and storage.
Break Room (Table 5-2.22)	A room containing a wet sink, coffee service, refrigerator, microwave, and vending machines.
2M Room (Table 5-2.23)	A room for Micro-Maintenance repair. Refer to NAVAIR 01-1A-23 for additional requirements.
Secret Internet Protocol Router Network (SIPRNet) Room (if required)	For certain facilities, a room for SIPR equipment must be provided. Discuss space requirements with facility user.
Ground Electronics Maintenance Division Area	Provide an area for Ground Electronics Maintenance Division, including: <ul style="list-style-type: none"> 1. GEMO Office 2. ET Chief Office 3. GEMD Admin/LPO Area
Mechanical Yard	A screened maintenance yard must be provided for the chiller, back-up generator fuel tank, garbage dumpster with a separate screen wall enclosure, generator, transformer, etc.

2-4.2.4 Adjacencies and Layout.

Appropriate building adjacencies are illustrated in Figure 2-8. This diagram does not convey a building shape, but represents the required adjacencies in a typical Radar Approach Control facility.

Important adjacency requirements include the following:

- ATC personnel normally request that an ATC/Simulator/Training Room be located adjacent to the Operations/IFR Room.
- Maintenance personnel normally request that the IFR Equipment Room be located adjacent to the Main Distribution Frame (MDF) Room.

Figure 2-8 RACF Adjacency Diagram

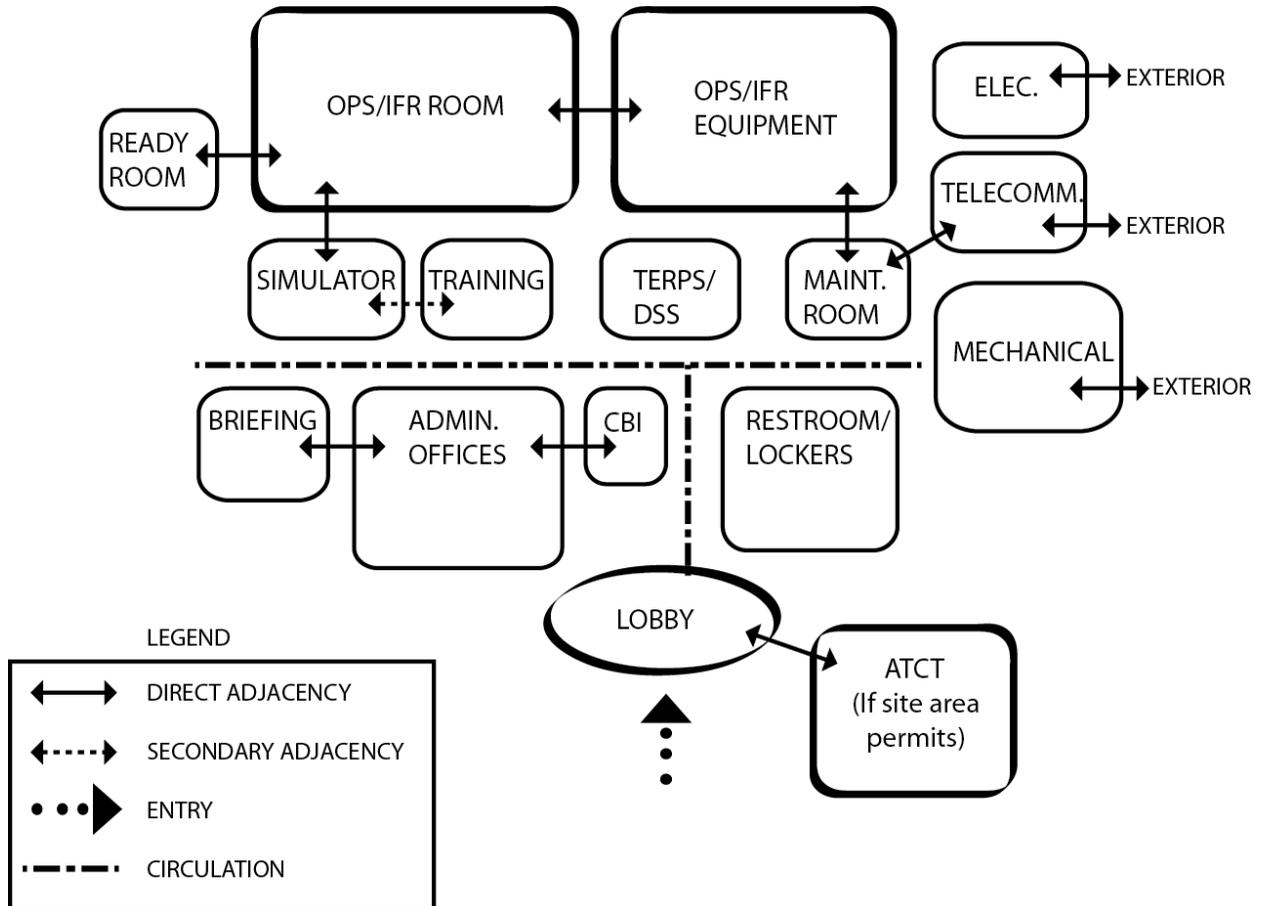

Note: The RACF Adjacency Diagram is only illustrative, and is intended to demonstrate typical relationships between programmed spaces. It does not exclude other floor plan geometry, building configurations or additional spaces required. More refined floor layouts should be developed during the design phase.

Figure 2-9 RACF IFR Room

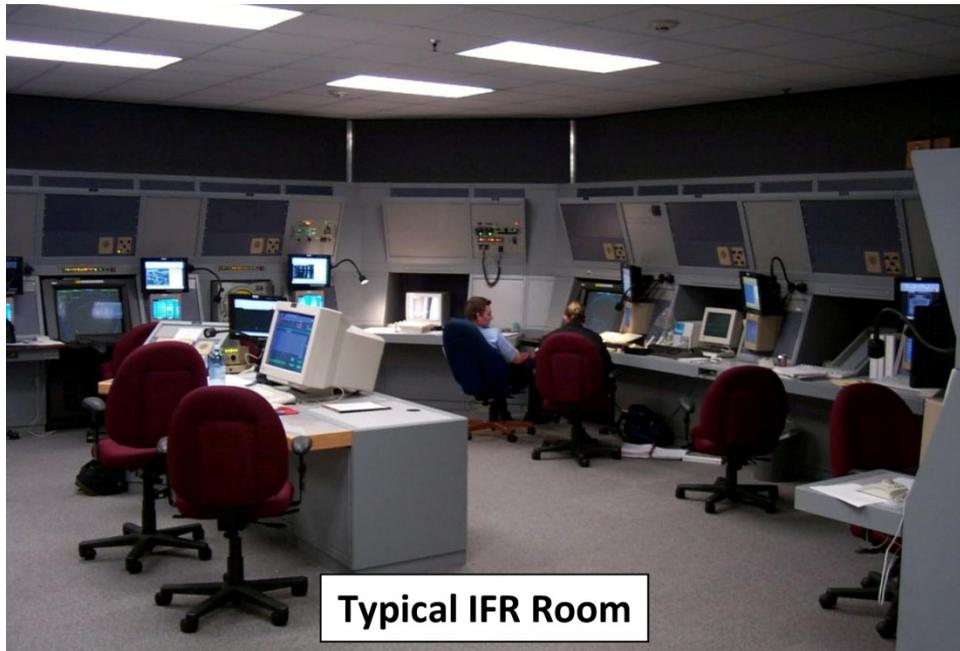
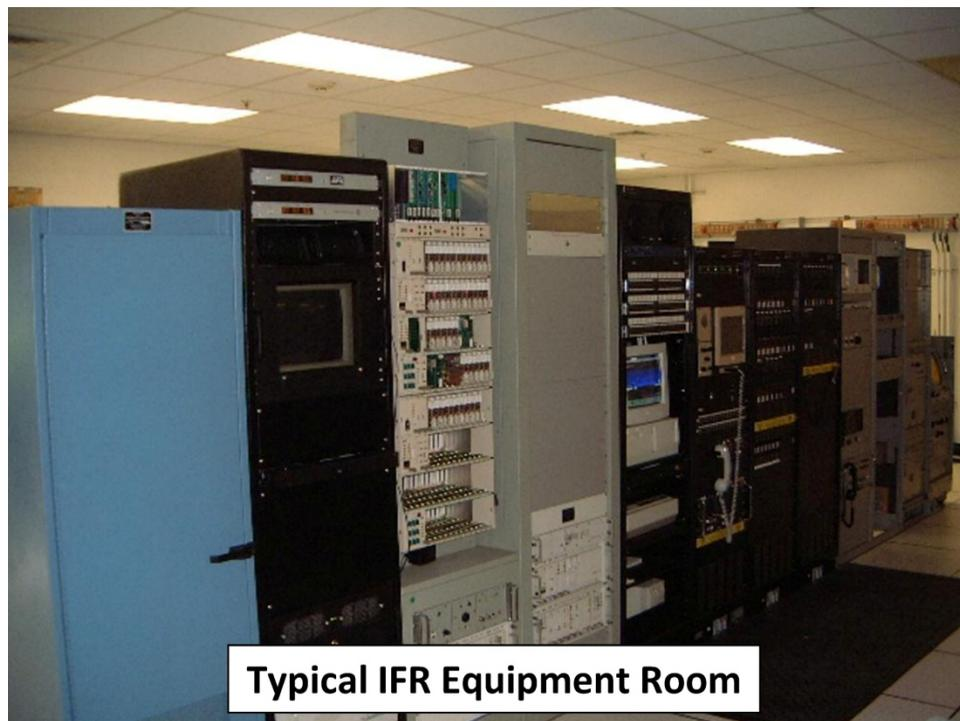

Figure 2-10 RACF IFR Equipment Room



2-4.3 Airfield Operations Building (AOB).

2-4.3.1 Function.

The Airfield Operations Building (AOB) is required to house flight operational and administrative functions of the airfield headquarters. The AOB includes all the functions of flight planning, flight personnel equipment and support rooms, passenger support facilities, and the communications, operations and weather services. Also included, unless otherwise provided in other permanent facilities, are an in-flight kitchen and/or snack bar, and a conference and/or briefing room which may also serve as a personnel training room or classroom. Because of differences in the aviation missions and the requirements of the facility commanders, the components for an AOB may vary considerably. The existence of available permanent facilities will also affect overall space requirements.

Certain airfield installations may enlarge the AOB to include the Airfield Headquarters (HQ). The Airfield HQ includes administrative space for the commander, military personnel, safety officer, and others.

2-4.3.2 Location.

The AOB adjoins the ATCT and RACF where site conditions permit. The AOB may be housed in a separate building or may be combined into a single structure with the ATCT.

The Air Operations Building must be located with direct access by personnel outside the airfield restricted area boundary.

2-4.3.3 Functional Program Areas.

Typical functional program areas are listed and described briefly in Table 2-4 and described in greater detail in Chapter 5.

Note: Not all AOBs contain all of the areas listed in the table. The functional areas required are dependent on operational requirements, and the functions required are determined by the user during the planning/DD 1391 development phase.

Table 2-4 Airfield Operations Building Functional Program Areas

Functional Program Area	Description
Lobby/Vestibule (Table 5-3.1)	Main entrance to the AOB. Include vestibule in cold weather climates.
HQ / Command Suite	The HQ/Command Suite must be tailored to the specific requirements of each command echelon.
HQ/Command Suite - Reception Area (Table 5-3.2)	Controls access to the HQ/Command suite. Include receptionist workstation, visitor seating area, coat closet, and supply closet.
HQ/Command Suite – Private Offices (Table 5-3.3)	Provide Private Offices for: <ol style="list-style-type: none"> 1. Airfield Manager/Commander 2. Chief Controller (CCTLR) or Airfield Operations Flight Commander (AOF/CC) 3. Operations Officer 4. Airfield Safety Officer
Airfield Operations (Tables 5-3.4 – 5-3.8)	This space is comprised of several functional areas, including: <ol style="list-style-type: none"> 1. Air Operations Duty Officer 2. Airfield Management/Flight Planning 3. Pilot Flight Planning 4. Weather Station 5. Pilot Ready Room
Airfield Services (Tables 5-3.9 – 5-3.13)	Provide an area for Airfield Services consisting of: <ol style="list-style-type: none"> 1. General Purpose Workstations 2. Printer/Copier Station (non-secure data only) 3. Non-Sensitive Secure Storage Room 4. General Purpose Storage Room 5. File Storage Area 6. Fuel Handlers
ATC Equipment Maintenance Admin Area (Table 5-3.14)	An open office area with freestanding systems furniture workstations for administrative personnel.
ATC Equipment Maintenance Area (Table 5-3.15)	A room for ATC electronic equipment maintenance, including an area for soldering and storage.

Functional Program Area	Description
Break Area (Table 5-3.16)	A room containing a wet sink, coffee service, refrigerator, microwave, and vending machines.
Multipurpose Room (Table 5-3.17)	Briefings, conferences, press releases, and consolidated training.
Male and Female Toilet Rooms (Table 5-3.18)	Toilet rooms for administrative personnel and visitors should be provided near the main entrance.
Janitor (Table 5-3.19)	A separate room for janitorial supplies and equipment, located near the toilet rooms.
Mechanical Room (Table 5-3.20)	A room housing mechanical equipment servicing the AOB with a lockable door.
Electrical Room (Table 5-3.21)	A room housing electrical equipment servicing the AOB with a lockable door.
Telecommunications Room (Table 5-3.22)	This room is the first termination point for all copper and fiber optic cabling and fiber optic entering the facility. All incoming lines must be surge-suppressed in this room.
SIPR Room (if required) (Table 5-3.23)	For certain facilities, a room for SIPR equipment must be provided. Discuss space requirements with facility user.
Outside Covered Storage Area (Table 5-3.24)	One (1) outside storage building and one (1) outside covered storage area with fence and 10' wide lockable gate. The storage area is used to store airfield services related equipment and must have direct access to the parking aprons
Transient Passenger Services (Table 5-3.25)	Waiting area for transient passengers.
VIP Passenger Services (Table 5-3.26)	Waiting area for VIPs.

2-4.3.4 Adjacencies and Layout.

Appropriate building adjacencies are illustrated in Figure 2-11. This diagram does not convey a building shape, but represents the required adjacencies in an Airfield Operations Building.

Figure 2-11 AOB Adjacency Diagram

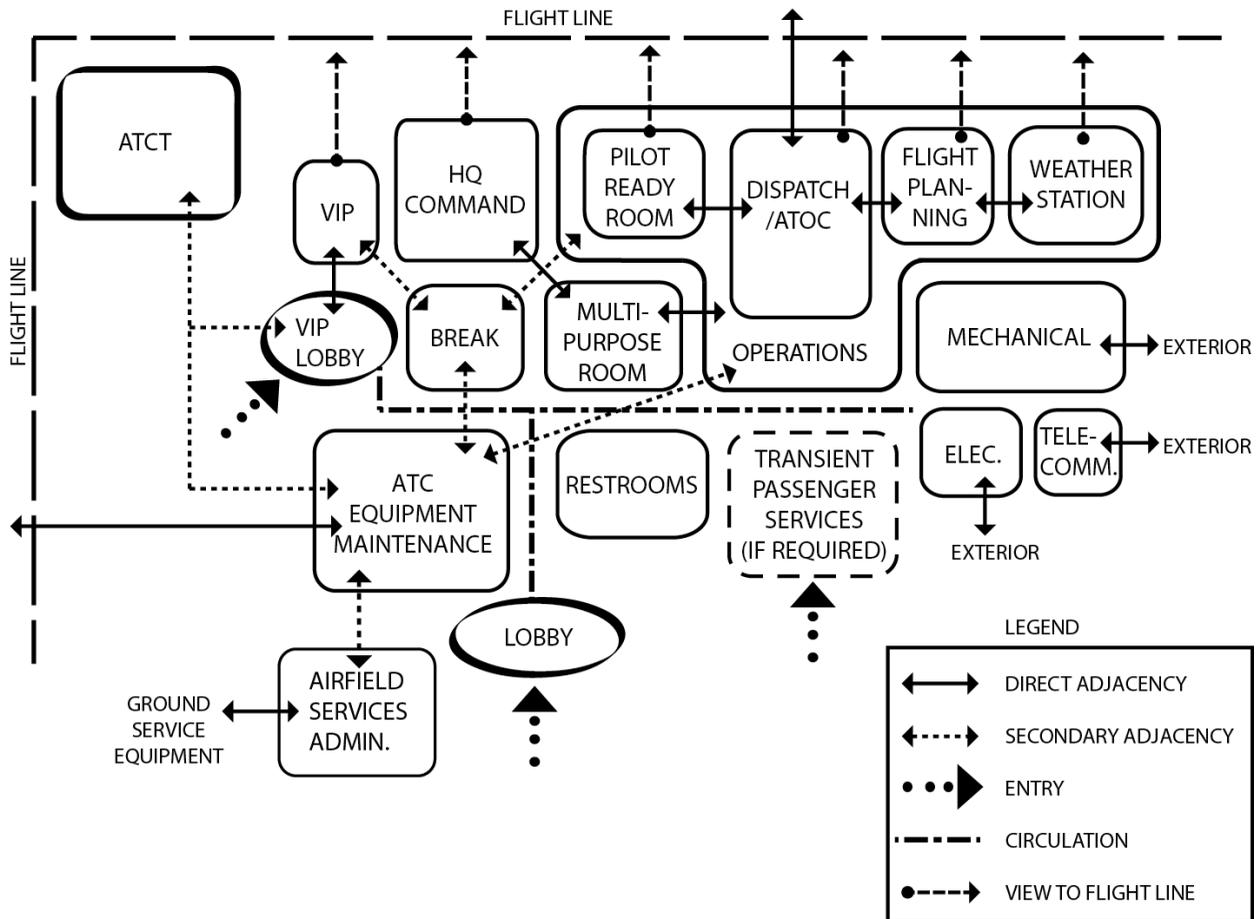

Note: The AOB Adjacency Diagram is only illustrative, and is intended to demonstrate typical relationships between programmed spaces. It does not exclude other floor plan geometry, building configurations, or additional spaces required. More refined floor layouts should be developed during the design phase.

2-5 COMBINING AIR TRAFFIC CONTROL AND AIR OPERATIONS FACILITY TYPES.

ATC and Air Operations Facilities may be provided in separate structures or combined into one structure. Locate the ATCT adjacent to the RACF where siting requirements permit. However, the ATCT may be separated from the RACF and the AOB in order to facilitate visual observation and control of aircraft movement.

2-6 SITE SELECTION AND APPROVAL PROCESS.

2-6.1 Site Location Requirements.

The location and height of the ATC and Air Operations Facilities must be based on a Siting Report that recommends the optimum location and relative orientation of all structures, including the optimum size and height of the ATCT.

Selection of a site within 1,000 meters (m) of a station Tactical Air Navigation (TACAN) system will require an analysis of impacts to the TACAN.

2-6.1.1 Air Traffic Control Tower.

The Air Traffic Control Tower (ATCT) must be sited in accordance with UFC 3-260-01, *Airfield and Heliport Planning and Design*. The ATCT must be physically oriented relative to the primary runways so as to obtain the best unobstructed view of the air installation complex and aircraft primary movement areas (i.e. runways and taxiways), their associated VFR and IFR approach paths, traffic pattern entry points, traffic patterns, ground routes, parking areas, and VFR and IFR departure paths. Consider planned runway and taxiway construction when siting the ATCT, as well as expected vegetation growth that cannot be cultivated due to various factors.

The ATCT itself should not be an obstruction or affect IFR operations. Care must be taken not to site the ATCT close to and/or under a flight path. When computing the height of the ATCT, the height of the antennas being installed (after construction is completed) must be included. The design of the antenna supports, installed as part of the construction, will affect the final antenna height. When computing the total ATCT height, the height of the tallest antenna must be added to the height of the top of the parapet wall or railing. The height of the lightning protection installed during construction must also be included in the total ATCT height if the lightning protection is designed to be higher than the antennas mentioned above. The total height of the ATCT, including antennas and lightning protection, must be shown on the design elevation drawings.

Other considerations for final siting include utility availability (water, sewer, storm, power, and gas), site access, security, and relationship to existing ATC Facilities and existing ATCTs. If an area directly below the ATCT requires controlling, consideration for relocating the ATCT to allow proper visual access to that area should be of prime importance.

All ATCTs have transmitting antennas on the roof. The site approval process requires that all projects having explosives safety, airfield safety, or electromagnetic safety

implications, require a “Safety Certification.” Also, consider the existing location of the airfield beacon during the site selection process. If the beacon will cause visibility problems for ATCT controllers, it will require relocation or a change in height, and should be included in the DD 1391 for the ATCT. The rotating beacon must not be located on top of the ATCT.

2-6.1.2 Radar Approach Control Facility.

The Radar Approach Control Facility (RACF) can be sited anywhere within the range of the equipment providing radar-assisted approach control. The RACF functions well in a single-story facility, making it a candidate for siting near airfields where building heights are restricted by airfield conical or imaginary surfaces.

Provide drive-up service access to service entries in the RACF, including the IFR Equipment Room, the Operations/IFR Room (through equipment room), and the Mechanical Room. Screen chillers, back-up generator fuel tanks, and dumpsters in maintenance/service yards.

2-6.1.3 Air Operations Building.

The Airfield Operations Building (AOB) can be sited anywhere within the air installation complex as long as it complies with the requirements of UFC 3-260-01. Preferred adjacencies are described above in Section 2-4.3.2.

2-6.2 Site Radiation Hazards.

Hazards of Electromagnetic Radiation to Personnel (HERP), Ordnance (HERO), and Fuel (HERF) surveys are crucial to the siting process. Radiating radio frequency (RF) antennas must be installed on top of the ATCT and a radiation hazard (RADHAZ) study to support their installation should be conducted during the site approval process. Facility siting criteria must consider radiating fields of existing antennas, such as the Airport Surveillance Radar (ASR), that support ATC operations.

Define the specific concerns with aiming of radar and various antennas so there is no interference from electrical propagation in the form of electromagnetic and RF waves.

2-6.3 Site Selection and Approval Process.

- **Army:** ATSCOM, through a site survey and in coordination with the USACE Transportation System Center selects the ATCT location. The IMCOM Regional Director, for the specific region approves the site location. The Headquarters, Department of the Army validates the project as part of the established Army process. Refer to project review requirements contained in AR 95-2.

Army National Guard Bureau: The Director, Army National Guard, through the State Adjutant General, approves the location and project. As is appropriate, the State Adjutant General may be the final approval for the site location and project.

- **Navy:** NAVFAC Asset Management and SPAWAR are responsible to conduct the siting study. When a tower siting study is performed, the TSAR analyzes multiple sites and recommends one.

Final site approval must be from the Base/Station Commanding Officer per current NAVFACINST 11010.45. A letter from the ATC Officer or Base/Station Commanding Officer selecting a particular site should be required.

- **Air Force:** The MAJCOM Programming and Requirements Manager requests a site survey from Headquarters Air Force Flight Standards Agency. HQ AFFSA will recommend a site selected for ATCF based on the survey results. Concurrence with the Base/Wing Commander signifies acceptance of the site recommendations.

Refer to Appendix C for an outline of a typical Site Selection Process.

This Page Intentionally Left Blank

CHAPTER 3 GENERAL REQUIREMENTS

This chapter describes the general design criteria shared by all Air Traffic Control (ATC) and Air Operations Facilities.

3-1 AIRFIELD SAFETY.

Federal Regulation 14 CFR Part 157, section 77.13 requires FAA notification for anyone proposing to construct, alter, or deactivate a civil, military, or joint-use (civil/military) airport. Provide obstruction marking or lighting for facilities located in or near aviation operational areas in accordance with UFC 3-535-01, *Visual Air Navigation Facilities* and FAA Advisory Circular AC 70/7460, *Obstruction Marking and Lighting*.

3-2 ARCHITECTURAL.

3-2.1 Future Expansion Capability.

Discuss future expansion potential with local ATC operations personnel. If required, plan for building design that permits incremental additions. Future expansion capability should be carefully planned into the overall design. Future growth must be assumed to be horizontal and not vertical.

3-2.2 Acoustics/Noise Control.

Sound attenuation is necessary for all ATC and Air Operations Facilities in order to control disturbance from high energy noise levels and to minimize disturbance from intrusive speech. Acoustical control is required around toilet rooms, conference/training rooms, and private offices, as well as specialized spaces required in each facility type. Refer to Chapter 5, Functional Data Sheets, for specific sound level criteria for all rooms.

3-2.3 Accessibility for the Disabled.

Comply with the DoD Architectural Barriers Act Accessibility Standards (ABAAS), and provide barrier-free access to civilian workspaces and other spaces intended for public access.

3-2.4 Exterior Materials.

During design, a TACAN Subject Matter Expert must review the facility's proposed exterior materials and their possible impact on TACAN operations. Depending upon the materials used for the outside of an ATC or Air Operations Facility, the impacts can vary for the same location. Some exterior wall materials may interfere with TACAN operations. An example would be that corrugated steel siding would scatter the signal vice acting as a standard reflector and could degrade the signal enough to make the TACAN unusable.

3-2.5 Reflective Surfaces.

To prevent mirror-like reflections from building surfaces to aircraft in flight and air traffic controllers, provide roofs and other external surfaces with a specular reflectance compatible with the location of the building on the airfield. If the building is so located that glare may be an operational hazard, provide the critical surfaces of that building with a light reflectance of not more than 10, measured at an angle of 85 degrees in accordance with the ASTM D 523, *Standard Test Method for Specular Gloss*.

3-2.6 Windows.

Windows in ATC and Air Operations Facilities must comply with UFC 4-010-01, *DoD Minimum Antiterrorism Standards for Buildings*. In addition, windows must meet EAct-2005 and EISA-2007 energy requirements.

Consider windows for administrative and break areas, but do not provide windows in electronic equipment rooms, the RACF Operations/IFR Room, storage rooms, or mechanical and electrical rooms.

3-2.7 Raised Access Flooring.

Where required, provide Raised Access Flooring (RAF) to meet the requirements of NFPA 75, *Standard for the Protection of Information Technology Equipment*. RAF must be supported around the entire perimeter. Provide a bolted grid (stringer) or a rigid grid system. Utilize 24-inch (610 mm) stringer supports throughout (larger supports are not acceptable). Pedestal support systems without horizontal stringers must not be used.

The space between the concrete sub-floor and all raised access flooring will be used to route ATC system cabling to the electronic equipment. Ensure that there is no structural steel in these areas, including any additional seismic bracing that may be required. Keep all air supply panels and similar inserts flush with the flooring surface. Specify installation procedures to conform to FAA-STD-019e and FAA-STD-020b. Provide depressed structural framing and slabs in areas where access flooring occurs to result in uniform, continuous finish floor levels between adjacent floor spaces. Provide a RAF installation above a level permanent floor when it is not economical or practical to depress the structural framing and slab.

3-2.7.1 Bonding and Grounding of RAF.

RAF must be electrically continuous, properly bonded and grounded. Both systems must be connected to the below-floor signal reference grid system and to the perimeter ground cable with copper straps or cable that meets FAA-STD-019e. Stringers of the bolted grid must also be bonded per FAA-STD-019e.

3-2.7.2 Design Loads for RAF Installations.

Use the following Design Loads for RAF installations:

- Rolling: 400 lb min.

- Impact: 100 lb min.
- Concentrated: 1,000 lb. min.

3-2.7.3 RAF Floor Tiles.

Provide filled or unfilled floor tiles with integral, static dissipative carpet or vinyl coverings. The use of filled or unfilled floor tiles must be determined during the planning/DD 1391 development.

If carpeted floor tiles are required, carpet squares must be factory glued or glued to the tiles using adhesive provided by the manufacturer of the floor tile and per the manufacturer's instructions. Carpet squares must have the same dimensions as the RAF panels, instead of tiles with vinyl trim. Spare carpeted tiles (25% of installed area) and one quart of the same adhesive used must be provided and turned over to local ATC personnel upon completion of construction. The adhesive must be provided from the floor manufacturer.

3-2.8 Floor Finishes.

All exposed concrete floors or sub-floors without floor or carpet finish must be cleaned and sealed or painted with an appropriate type of concrete sealer or paint. Floors must be sealed prior to the installation of any conduits, piping, ventilation ducts or RAF.

3-2.8.1 Electronic Equipment Area Floor Finishes.

All areas housing electronic equipment must have static dissipative floor finish materials with a surface resistance between 2.5×10^4 and $1.0 \times 10^8 \Omega$ (ohms) measured in accordance with the ANSI ESD S7.1. Electronic equipment spaces must be provided with static dissipative carpet or laminate or vinyl tile. Cut pile carpeting with a performance factor of less than 2.0 (kV) static generation under worst possible conditions should be required for high traffic areas.

3-2.9 Building Signage.

Building directory, bulletin boards and interior signs must be in accordance with UFC 3-120-01, *Air Force Sign Standard*, unless directed to use installation standards. Confirm final details including size and location for all building signage with user group during the design phase.

- Provide a suitably sized building directory located near the main entrance of each ATC or Air Operations Facility. The directory case must be constructed of extruded aluminum with an architectural finish. It should have a changeable letter board with insertable letters and a sliding glass front.
- A bulletin board is required in the entrance. The bulletin board must be similar in construction to the building directory, except with a cork backboard.

3-2.10 Locker Area.

The locker area provides a space for ATC and Technical Operations personnel to secure their personal belongings while on duty, and serves as a place to store work equipment while off duty. All facets of locker rooms must comply with DoD ABAAS requirements. Include showers with changing rooms and half-height lockers (60% male/40% female). In overseas locations, full-height lockers must be provided.

3-3 STRUCTURAL.

3-3.1 Structural Design.

Except as indicated herein, use the model codes with modifications specified in UFC 1-301-01 along with other applicable UFC documents to develop design documents. Special design requirements for each facility type are provided in Chapter 4.

3-4 MECHANICAL.

3-4.1 Indoor Design Conditions.

The mechanical systems serving ATC and Air Operations Facilities must be based on maintaining the following temperature and humidity requirements:

Critical Spaces: Certain spaces in all ATC facilities are considered Critical and must have the capability to maintain certain temperature/humidity sound level design conditions. Normally, Critical spaces include the Control Cab, Communications Equipment Room, RACF Operations/IFR Room, UPS/Battery Room and all ATC Electronic Equipment Rooms.

- Temperature: 73° F stable $\pm 2^\circ$ F
- Humidity: 35% to 60% R.H
- Control Cab and RACF Operations/IFR Room Sound: Maximum NC 35
- Equipment Room Sound: Maximum NC 45

Refer to Chapter 5, Functional Data Sheets, for information on program areas identified as Critical Areas.

3-4.2 Air Conditioning Loads.

Equipment heat loads must be provided during the planning/DD 1391 development process. Loads must be calculated using normal air conditioning load calculation procedures. Do not consider heat loads from electronic equipment when calculating heating requirements. Loads must be based upon personnel occupancy. Loads due to electronic equipment must be verified during design.

3-4.3 Acoustics/Noise Control.

HVAC system noise control is required for ATC facilities and electrical and mechanical rooms must be designed to control sound attenuation. Sound traps must be used, as required, on the supply and/or return air duct openings and where return air passes through sound treated walls. To minimize HVAC noise, equipment must be mounted on vibration isolators. All rooftop mounted air-handling systems and packaged air conditioning systems must be strategically mounted to alleviate noise attenuation.

3-4.4 General HVAC Requirements.

Detailed descriptions of required spaces and HVAC system requirements are as follows:

3-4.4.1 Radar, Communication, and Telecommunications Rooms.

These spaces house solid state electronic equipment and require complete heating and air conditioning. Cooling and humidity control is required for reliable equipment operation and cooling loads are generally constant, 24 hours per day, except during additions or equipment modifications. Humidification is required to prevent electrostatic charges from derogating equipment performance.

Multiple units designed for computer room environments must supply each equipment room. Two air handling units must house humidifiers and each must be sized for the maximum load for redundancy. Ventilation requirements are based on occupancy and the designer must collect information about room personnel occupancy during the planning process. Specialized computer room HVAC systems with air distribution through the RAF must be installed, and high efficiency air filtration must be integrated into the systems to minimize dust and contaminants.

3-4.4.2 Administrative Spaces.

These spaces require normal office environment cooling, humidification, and heating systems. Heating and cooling loads are variable. Administrative spaces are not normally occupied more than eight (8) hours a day and must be zoned by occupancy hours and similarities in comfort control requirements. Use night setback thermostats in areas occupied for eight (8) hours per day. HVAC systems with VAV are preferred and zones must be determined from building size and layout.

3-4.4.3 Break Rooms.

Provide HVAC capacity for 24-hour per day operation to handle the heat generated by existing and planned vending machine, cooking equipment, refrigeration compressor associated with under-the-counter refrigerators, and drinking water remote chillers when provided. The kitchen area must have its own exhaust fan ducted to the outside which is activated by a switch located near the cook-top or microwave oven.

3-4.4.4 Toilet, Shower, and Locker Rooms.

Provide tempered conditioned supply air ducted directly to toilet room ceilings in the amounts only as required to compensate for heating or cooling thermal envelope loads. Louvered door makeup air must not be used if toilet room entrance walls are fire-rated. Door louvers or undercuts must not be considered if requirements exceed 100 cfm (47.2

lps). Where appropriate, the exhaust fans serving toilets (and adjoining janitor closets) must be interlocked with the building HVAC fan(s). In low activity buildings without central HVAC systems, toilet rooms may be equipped with an exhaust vent fan operated with the room lighting switch.

3-4.4.5 Emergency Generator (E/G) Rooms (if required).

For summer conditions, provide an exhaust fan that is mounted to the side or on the building roof and is weatherproof for space ventilation, activated by an adjustable thermostat. Provisions must be considered to maintain room temperatures a maximum of 10° F above ambient conditions. Design must preclude drawing outside air that could be contaminated by the battery room exhaust. An additional high volume fan is required for simultaneous operation with the generator set. This fan must be sized to draw air through the E/G space at a rate sufficient to provide the necessary heat removal for the specified E/G. Alternatively, a two-speed thermostatically activated fan with activation set-points, sized as noted above, to operate with E/G operation, may be considered. Air intake for both normal ventilation and high-volume exhaust fans must be via low efficiency filtered storm-proof outdoor air louvers or intake hoods with multi-blade (sectioned) low-leakage motorized control dampers (insulated airfoil dampers or similar type preferred for all heating climate zone I through III inclusive). Dampers on fan intake throats must be of similar type, motorized, and interlocked with either fan operation or barometric backdraft.

For installation in colder northern regions, a low ambient thermostatic damper control to interlock intake damper blade sections for high volume exhaust fan to preclude the full damper area from opening on E/G start-up when outdoor ambient is below freezing. Other design options can be considered. For E/G sets equipped with bed-rail mounted integral radiators, the high volume exhaust fan is not typically required as air is drawn over the engine and discharged to the atmosphere via the integral radiator fan (requirements must be verified individually for such installations). E/G space must be provided with a thermostatically-activated unit heater to maintain this space at no less than 50° F.

3-4.4.6 UPS/Battery Equipment Rooms.

This room must be served with two 100% redundant cooling-only constant volume air conditioning systems with minimum MERV 11 filtration. Air-cooled direct refrigerant expansion condensing units, geothermal, and variable refrigerant volume systems are permitted when chilled water is not selected as a primary cooling source. Automatic switchover must be provided in the event of failure of the primary unit. Air distribution must be via an overhead or low sidewall supply directed toward the UPS gear base (integral) ventilation intakes. The UPS gear cooling load is continuous, 24-hours per day, year round, and is approximately constant. Consider the option of incorporating a hydronic run-around-loop heat recovery system or air-to-air heat exchanger for preheating winter ventilation air when justified by life cycle cost analysis. Outside air economizers must not be used due to dust and/or humidity exposure to the sensitive equipment within this room.

3-4.5 Energy Conservation.

The designer must use UFC 1-200-02, *High Performance and Sustainable Building Requirements (August 2012)* for guidance in developing an energy efficient design for ATC and Air Operations Facilities.

The use of alternate sources of energy, such as wind or solar, should be checked carefully to ensure any equipment required will not cause interference issues with the ATC equipment. System maintenance by local personnel should also be considered.

3-4.5.1 Solar Photovoltaic, Solar Lighting, and Heating.

The location of solar collectors should not create a sun reflection problem for aircraft or ground movement on the airfield.

3-4.5.2 Economizer Cycles.

Economizers should be provided as required by ASHRAE 90.1 except for the HVAC systems serving rooms with ATC electronic equipment, such as the ATCT Control Cab, the RACF Operations/IFR Room, all ATC electronic equipment rooms, all UPS Rooms, and all telecommunications rooms.

3-4.6 HVAC System Selection and Location.

HVAC systems should be located on the floor above or below the level housing the equipment. This allows better maintenance access to the mechanical equipment and the likelihood of an HVAC water leak causing damage to electronic equipment is reduced. Locating HVAC and related equipment above the ceilings in occupied Critical areas must be avoided to eliminate problems associated with noise, vibration, and access. Air conditioning equipment serving Critical spaces must be provided with low ambient control to allow cooling in the winter season. ATC Electronic Equipment Rooms with Raised Access Flooring (RAF) must be cooled by multiple floor-mounted Computer Room Air Conditioner (CRAC) units due to anticipated ceiling height restrictions. Rooms without raised access flooring may be served by CRAC units or overhead distribution from adjacent air handling units. The space required for CRAC units and other equipment, including ATC equipment and building systems, must be considered. CRAC units designed for RAF systems must only be used in rooms with RAF systems.

3-4.7 Critical Space Redundancy.

All Critical spaces in ATC and Air Operations Facilities must be provided with 100% redundancy so that if one unit goes down another unit must be capable of handling the entire load. Also, electronic equipment rooms typically need cooling, even when other rooms need heat. Consider having electronic equipment rooms on a dedicated, redundant unit with both humidifying and dehumidifying capabilities.

All cooling systems (central air handling units, DX package units, DX split systems, chillers, pumps, etc.) serving Critical spaces must have 100 percent redundancy and preclude any single-point failure. Include in commissioning requirements to confirm that all equipment serving critical spaces is connected to a power source that is backed up by the E/G.

If chilled water systems are selected, the systems should be sized for 75% (60% allowable with approval) of peak load for the entire facility. The chillers should share the entire load with the primary and secondary units alternating on a user programmable schedule. In the event of a chiller failure, control must be such that the non-Critical loads (all areas other than control cab and electronic equipment rooms) can be dropped. Alternate use of chillers and equalize run time to lengthen life span and improve efficiency. VRV systems must not be used. The use of dedicated Outside Air Units must be considered.

3-4.8 Air Filtration.

The inclusion of highly sensitive electronic equipment in ATC and Air Operations Facilities requires the use of high-quality air filtration systems. High-efficiency filters must be installed in equipment serving Critical areas. In addition, a minimum of 2-inch (50-mm) thick disposable MERV 7 pre-filters must be used in all units. If severe fuel/exhaust odor problems are anticipated due to site location, charcoal filters may be used for outside air intakes serving Critical areas.

Careful consideration must be made for specification of these systems due to the size and high maintenance cost of these filters. High-efficiency filters must be rated at a minimum of MERV 11. Electrostatic air filters may be considered for the Critical spaces in locations with high ambient dust levels such as airports in desert areas. During design, care must be taken to ensure that these filters will not produce electronic feedback or allow harmonics back into the system.

3-4.9 Equipment.

Computer rooms and electrical equipment rooms produce predominantly sensible heat and require specially designed HVAC equipment for optimal performance. Ensure mechanical systems do not interfere with electronic equipment or radiated signals. Provide adequate clear heights in MEP rooms for maintenance personnel throughout ATC and Air Operations Facilities.

Ensure that the locations of mechanical devices in ATC Facilities do not interfere with electronic systems to be installed or the support devices installed in conjunction with ATC equipment. In addition, ensure that mechanical assemblies do not interfere with post-construction access to power panels, cable chases, equipment hatches, or roof hatches.

Provide a snorkel type localized stand-alone exhaust system with timer and 100 fpm capture velocity for any spaces where soldering occurs.

3-4.10 Thermostats.

Remote and local control of thermostats can be allowed in spaces with ATC equipment but must be restricted to the temperature limits as defined in paragraph 3-4.1.

3-4.11 Batteries.

Wet cell lead acid or nickel-cadmium batteries must not be designed for use in the ATC Facilities, except as approved for emergency lighting.

3-5 PLUMBING.

3-5.1 Design Criteria.

Consult with the electrical and architectural design engineers to ensure that plumbing does not interfere with the cable tray installation.

Plumbing design must use UFC, 1-200-02, *High Performance and Sustainable Building Requirements* (August 2012).

3-5.2 Restrooms.

Vitreous china fixtures must be used in all restrooms. Flush valves must be used on ground or second floor only. Tank-type fixtures must be used above the second-floor elevation. Wall-mounted fixtures must be used whenever possible. Provide accessible fixtures required by DoD ABAAS for disabled access. Consider in-line hot water heaters for ATCT restrooms.

3-5.3 Emergency Generator (E/G) Rooms (if required).

An emergency eyewash station must be provided within the E/G Room. A floor drain should not be provided because of the potential for contamination of the sanitary sewer system with diesel fuel.

3-6 FIRE PROTECTION AND LIFE SAFETY.

3-6.1 Type of Construction.

Construction type must be in accordance with UFC 1-200-01.

3-6.2 Definitions:

- Control Cab: That portion of a building or structure used for the control of aircraft by visual observation, radio communication, and/or radar by Air Traffic Control specialists.
- Tower Shaft: That portion of a building, facility, or tower that structurally supports a control cab used for housing minimum mechanical, electrical power, and electronic equipment.
- Base Building: Buildings used for housing support equipment and personnel for ATC activities.

3-6.3 Floor and Wall Penetrations.

All ducts and chases must be fire/smoke-stopped by an approved and listed method. Through-penetration assemblies must be provided in cable duct wall penetrations in accordance with NFPA standards after installation of cables.

Openings in rated walls and floors for cabling, whether installed at the time of construction or for later use, must be completely filled and fireproofed, with a listed assembly. The fire rated assembly must permit repeated removal and replacement, without special tools, as necessary for the installation of cables and to support changing requirements.

3-6.4 Raised Access Flooring Areas.

Raised Access Flooring (RAF) areas may be used as supply air plenums only. Return air plenum use is not allowed.

All cabling and conductors installed in RAF areas must be plenum rated or installed in metal conduit or EMT.

3-6.5 Fire Suppression Systems.

For the purposes of the design and installation of suppression systems only, ATC and Air Operations Facilities are not to be considered “mission critical.”

All areas of ATC and Air Operations Facilities must be protected with wet pipe fire-suppression sprinkler systems. A single fire suppression system may serve an ATCT and an attached adjacent RACF provided that separate water flow indicators are provided for each.

Provide for concealed mounted sprinklers where suspended ceilings are installed.

3-6.6 Fire Alarm and Detection Systems.

Provide intelligent addressable fire alarm, detection and mass notification systems in all ATC and Air Operations Facilities. Audible notification shall be voice messages via speakers. The fire alarm and mass notification systems shall share speaker circuits and notification appliances.

Carbon Monoxide detection, in accordance with NFPA 720, is required in any facility provided with fossil-fueled equipment, such as a generator, boilers, hot water heaters, etc.

A single fire detection and notification system may serve an ATCT and attached adjacent RACF provided separate notification zones are provided for the ATCT and the RACF to prevent simultaneous evacuation of both technical areas.

3-6.7 Electronic Equipment Spaces.

3-6.7.1 Separation.

Provide separation from other areas of the facility with one-hour fire resistance-rated assemblies.

3-6.7.2 Automatic Sprinkler System.

Provide a wet pipe sprinkler system in Electronic Equipment Spaces (EES).

- Provide guards for sprinklers in EES's without ceilings. Provide concealed sprinklers for EES's with drop ceilings.
- Provide a single fire suppression line supplying the sprinklers in EES. This supply must be provided with a supervised shut off valve, check valve, flow switch, and test valve.
- Actuation of the flow switch must remove power to the electronic equipment.

3-6.7.3 Fire Alarm System.

For the EES:

- Provide smoke detection at ceilings, connected to the building fire alarm system to transmit local and remote signal as well as to activate the extinguishing system where provided.
- Provide manual fire alarm stations at all doors from the EES.
- Smoke detector(s) shall be spot type utilizing a laser light source technology. It shall be able to recognize and transmit at least two separate alarm threshold signals.
- Provide local audible alarm notification in each EES. The fire alarm system must be configured such that the first threshold smoke detection signal shall annunciate an alarm at the Fire Alarm Control Panel (FACP) and all remote annunciators, if provided, and initiate alarm notification from the local audible alarms, but will not initiate evacuation alarms throughout the facility.
- A signal indicating second threshold smoke detection, or a detection signal from a second detector, if provided in the EES, will silence the local alarm and initiate the facility evacuation system.
- Do not install heat/smoke detectors directly above ATC equipment cabinets. Equipment locations will be determined during design.

3-6.8 Seismic Restraint.

Fire protection systems and components shall be braced against damage from movement such as from seismic activity, regardless of the probability of such activity. Design and installation of system bracing shall be in accordance with the applicable design standards such as NFPA 13, NFPA 14, NFPA 70 and NFPA 72.

3-7 ELECTRICAL.

The criterion set forth in this section includes the minimum functional and design requirements of interior and exterior electrical systems for ATC and Air Operations Facilities. The power distribution system and components must meet overall power system and Critical system reliability requirements.

3-7.1 Emergency Electrical Power.

3-7.1.1 Emergency Generator.

All electrical power provided to ATC and Air Operations Facilities is considered “Essential”, requiring back-up by an Emergency Generator (E/G). This Essential power must be supplied on a split-bus system, which is herein denoted as Critical and “Non-Critical”. Equipment to be supplied from the Critical bus is limited to the ATC electronic equipment, the signal light guns, and select non-ATC computers, LAN, or other technical equipment that may be required. Non-Critical circuits include the facility mechanical and building systems, such as the HVAC, lighting, and fire protection systems.

To ensure equipment operation during extended power outages, the HVAC systems serving Critical spaces must be on E/G power. If an ATCT is located adjacent to an RACF or AOB, a common emergency generator must be considered.

3-7.1.2 Emergency Generator Location.

Consider an outdoor unit with a weatherproof enclosure in mild climate conditions. Where the E/G is located in a cold climate, the emergency generator must have an in-block heater to facilitate rapid start-up during cold winter snaps. If the cold weather is extreme, utilize a crankcase engine lubricating oil heater to reduce the oil’s viscosity and facilitate an easier and faster start. Consider the use of a battery heat jacket in extreme frigid weather to facilitate full battery cranking power. An ether injection system for direct injection into the engine’s intake manifold will enhance starting capability during very frigid weather.

Consider a below-ground generator vault for units which must be sited within airfield clear zones or primary surfaces.

3-7.1.3 Emergency Generator Fuel Storage.

- Design fuel storage for diesel or jet fuel powered generators in accordance with:
- UFC 3-460-01, *Design: Petroleum Fuel Facilities*, state and local regulations, and the following:

- Title 40, CFR Part 112, *Oil Pollution Prevention*
- Title 40, CFR Part 113, Liability Limits for Small Onshore Storage Facilities, Subpart A “Oil Storage Facilities”

Provide fuel storage capacity for a minimum of 36 hours of continuous generator operation. This will account for periodic engine testing while ensuring at least 24 hours of fuel supply for the full required load during an actual electrical emergency. Provide separation between fuel storage tanks and adjacent buildings, parking aprons and property lines in accordance with UFC 3-460-01. Provide double wall storage tanks and piping. The screen wall surrounding an exterior fuel storage tank must be at least 6 inches (150 mm) taller than the tank. Underground fuel storage tanks are not allowed for ATC Facilities.

3-7.1.4 Emergency Lighting.

Emergency lighting must be connected to the emergency bus and will have 100% backup power from the E/G. Stairways, exit corridors and vestibules must have sufficient general building luminaires connected to the emergency system to provide emergency exit illumination. Also provide emergency lighting at the UPS and backup generator systems for reading any operating instructions.

In addition, each continuously occupied room and each ATC Electronic Equipment Room must be supplied with at least one (1) light from circuits powered by the E/G. Consider providing additional emergency fixtures (conventional with battery back-up or inverter/rectifier located in the fixture ballast) in other locations if determined by local ATC personnel.

3-7.1.5 Emergency Power-Off Switch.

Per NFPA 70, a means to immediately secure all incoming Critical power is required in the ATC electronic equipment spaces and the Facility MDF. These Emergency Power-Off (EPO) switches must cause a main breaker trip (by activating a shunt trip) in the Critical power panel feeding the associated room. Under-voltage type devices must not be used. Circuit breaker number one of the associated power panel must be reserved for shunt trip power. (Local regulations must be consulted for deactivating each facility UPS via an EPO switch. Deactivation is required if over 600 VAC).

The EPO switch must be conveniently located in a conspicuous location near the room entrance(s), readily visible, and protected from accidental activation by means of a protective hinged cover. The EPO switch must have a label stating "Emergency Power-Off." Resetting after activation does not have to be controlled from within the space. An audible alarm on the EPO switch cover is not required.

3-7.1.6 Uninterruptible Power Supply (UPS).

Provide an Uninterruptible Power Supply (UPS) system in ATC and Air Operations Facilities for all Critical technical loads and the specific requirements of the Program Authorities. Install the UPS system in accordance with MIL-HDBK-1012/1, *Electronic*

Facilities Engineering. The UPS system must feed all Critical power panels. UPS sizing calculations are the responsibility of the Designer of Record.

- By design, UPS units must be physically near the load to be served. The UPS must be sized to provide the critical loads with power (plus a 25% spare capacity) for a minimum of 15 minutes to allow the E/G to start, stabilize, and assume the load. Provide remote monitoring of the UPS from a location determined by local ATC personnel.
- Connect the UPS so that the E/G provides input to the UPS during facility power outages. The UPS must be "double conversion" type. UPS output converters must include an isolation transformer. Size and install grounding electrode/bonding separately for derived neutral in accordance with the National Electrical Code (NEC). The UPS must be provided with dual inputs (one Normal UPS input and one Bypass input).
- The UPS is not normally located in the electronic equipment rooms due to space limitations, but must be located in a room serviced by the redundant HVAC system. The electronic equipment cabinets (to be installed after construction) will occupy most of the area in these spaces. If the UPS is to be located in any of these spaces, additional square footage will be required.

UPS systems that are built in are included in the MILCON construction and funding. Rack-mounted UPS systems for telecommunications, instrumentation or similar electronic equipment are not MILCON funded.

- **Navy:** Refer to OPNAVINST 11010.20 for updated guidance on UPS funding.
- **Army:** Refer to AR 415-15 for guidance on funding sources for UPS equipment.

3-7.2 400-Hz Power.

When required by the Program Authority, provide 400-Hz solid-state converter in accordance with UFGS 26 35 43, *400-Hz Solid State Frequency Converter*. Design in accordance with UFC 3-555-01N, *400 Hertz Medium Voltage Conversion/Distribution and Low Voltage Utilization Systems*. De-rate all 400-Hz cables and locate in separate non-magnetic raceway system. Also refer to MIL-HDBK-1012/1.

3-7.3 Grounding, Bonding, Lightning and Surge Protection.

Grounding, bonding, lightning protection, transient voltage protection, and shielding must be designed and installed in accordance with the requirements of NEC Article 250 and as specified in FAA-STD-019e, FAA-STD-020b, NFPA 780, Underwriters Laboratory (UL) 96A, Installation of Lightning Protection Systems, FAA-C-1217, and FAA Order 6950.19a. Specifically, ATC and Air Operations Facilities must have grounding electrode systems and safety grounding systems plus lightning protection, signal reference systems, and multipoint grounding systems. Designers should be aware that FAA requirements dramatically exceed those of the NEC. Special note: unless otherwise noted, there is no requirement for a single point ground system for ATC Facilities.

Lightning protection and grounding are crucial elements to an ATC Facility. Improper grounding and lightning protection can be the cause of many system failures and equipment damage. Any interruption of ATC services can cause severe flight safety issues.

3-7.3.1 Grounding.

Provide a grounding grid on all raised access flooring systems and isolated grounds for each piece of electronic equipment and equipment racks. Provide Equipotential Grounding Plane connections in the areas where equipment racks will be installed. Racks must be directly grounded for maintenance and should operate on a grounded power supply

3-7.3.2 Bonding.

Bonding of all metallic components in a facility is part of the complete facility grounding. Bonding of all metallic components in ATC Facilities is required per FAA-STD-019e. Special attention must be paid to the bonding of items that will be concealed upon completion of the construction effort, such as reinforcing bar.

3-7.3.3 Lightning Protection.

Due to the increased use of jointly procured (FAA/Department of Defense [DoD]) electronic systems for the National Airspace System Modernization (NAS Mod) Program, the lightning protection system requires that the structure be designed and installed per FAA-STD-019e.

Care must be taken to ensure lightning down conductors do not run within the building structure, take the shortest route possible, and are properly terminated to an earth ground. As specified in FAA-STD-019e, all down conductors are required to be connected to the earth electrodes by exothermic welds. This requirement must include the connection of any down conductors to the ground rod in the access well. The Government will ensure that all rooftop antennas installed by the Government are adequately bonded to the lightning protection system, and that all ATC antenna and ATC signal cables installed by the Government are adequately protected from lightning induced transients.

3-7.3.4 Transient Voltage Protection.

Transient voltage protection is required per FAA-STD-019e. Transient Voltage Surge Suppressors (TVSS) will help to prevent incoming surges from damaging any UPS installed. Additionally, the design must include TVSS on all critical power panels to prevent surge transmission between electronic equipment. TVSS is also required on any non-critical panels providing power to general-purpose outlets in any electronic equipment space. TVSS is optional on all other non-critical panels in the remainder of the facility. The lowest set of breakers (either right or left, according to which provides the shortest cable length) must be used in connecting the TVSS. Consult with local ATC personnel for additional non-critical power panel requirements.

The TVSS should be in a separate enclosure adjacent to the switchboard or panel board and be nipped with it. The nipple should be sealed with Oakum or duct seal.

3-7.3.5 Electronic Multipoint Ground System

An electronic multipoint ground system, per FAA-STD-019e, is required. This system must facilitate the interconnection of all non-current-carrying metal objects in the ATC Facility structure to the Earth Electrode System (EES). It is essential that no power grounds utilize this system.

- Electronic multipoint ground plates are required in ATC equipment spaces for the exclusive use of the ATC electronic equipment. One multipoint ground plate is required in the vicinity of the power panels in each of the ATC equipment spaces. A multipoint ground plate is not required in the Operations/IFR Room, IFR Equipment Room, ATC Simulator Room, or the ATCT Control Cab. The Signal Reference Grid (SRG) under the Raised Access Flooring (RAF) will be used to provide the grounding connection. Other multipoint ground plates may be installed as dictated by the facility design.
- All multipoint ground plates provided for ATC electronic equipment must be constructed of 4-inch (100-mm) wide x 20-inch (500-mm) long x 0.25-inch (6-mm) thick copper plate, mounted on standoff brackets. (NOTE: FAA-STD-019e states ground plates must be a minimum of 4 inches (100 mm) wide x 6 inches (150 mm) long). One half of each plate must have an evenly distributed pattern of holes, clear drilled for 0.375-inch (10-mm) hardware, on 1-inch (25-mm) centers. The other half must have a similar pattern of holes clear drilled for 0.125-inch (3-mm) hardware on 0.75-inch (20-mm) centers. All electronic multipoint ground plates in ATC Facilities must be mounted, have covers, and be labeled per FAA-STD-019e.
- To aid future testing of each facility grounding system, a Main Ground Plate must be installed in each facility, which must be easily accessible. The Main Ground Plate can be located in the IFR Equipment Room or in the ATCT Vertical Cable Chase on the ground floor. The Main Ground Plate must be identified by a predominantly green, permanently attached, plastic or metal label bearing the caption "MAIN GROUND PLATE" in black letters.

3-7.3.6 Electrostatic Discharge Prevention.

The electronic equipment to be installed in ATC Facilities will primarily consist of commercial off-the-shelf equipment containing circuit cards similar to those used in computer systems. This electronic equipment is highly susceptible to damage by electrostatic discharge (ESD). It is vital that design efforts concentrate on minimizing the potential for generating static electricity

All floors in rooms containing ATC electronic equipment have static dissipative surfaces connected to the electronic multipoint ground system and that floor coverings meet the requirements of ANSI-A148.1 (UL 779), *Electrically Conductive Floorings*. All chairs in rooms with ATC electronic equipment must have metal frames with conductive casters and chair-covering materials must have a low propensity to store static electricity.

Coordination with local Maintenance personnel is necessary to determine the requirements for any electronic repair or maintenance stations in ATC and Air Operations Facilities. If such work areas are requested, suitable ESD protection is required per FAA-STD-019e.

3-7.3.7 Earth Electrode System.

An EES is required for ATC Facilities per FAA-STD-019e. A survey to gather information concerning the subsurface conditions and soil resistance of the site is required per FAA-STD-019e. One access well is required per FAA-STD-019e so that periodic checks of the EES can be made.

At facilities that have two or more structures, the EES may be required to be interconnected per FAA-STD-019e. Additional guidelines are provided in FAA Orders 6950.19a and 6950.20.

3-7.4 Critical Power Distribution System.

All ATC and Air Operations Facilities require a Critical Power Distribution System (CPDS). Only 480 volt, three-phase, wye, three-wire distribution systems must be used, based on their superior harmonic resolution capability. This capability is applicable to all ATC and Air Operations Facilities unless 480 volt, three-phase utility power is not available.

ATC electronic equipment requires 120/208-volt service, and will generally be supplied from transformers 30 kVA to maximum 75 kVA (480 volt delta, 208Y/120 volt). The designer must follow guidelines in IEEE STD 1100, the Federal Information Processing Standard (FIPS PUB 94) power distribution publication for electronic equipment, and actual equipment loads to size transformer.

3-7.4.1 Main Distribution Panel Essential.

The Main Distribution Panel Essential (MDPE) will normally be rated 480 volt, 60 Hertz, three-phase, three-wire. This panel must be designed with a minimum spare capacity of 25 percent. All breakers 1000 ampere three-phase and higher must be installed in accordance with the NEC, have ground fault interruption protection option, and be rated to provide interrupting capacity in accordance with the short circuit study.

Provide an option to use 208 volt or 480 volt power. On smaller ATC Facilities, it could be more beneficial to use 208 volt power to eliminate the use of dry-type transformers.

3-7.4.2 Critical Power Panels.

Critical power panels are required for ATC Facilities. The critical power panels must be connected to the UPS and designated for ATC electronic equipment use. The combined equipment characteristics, estimated power panel loads, and proposed circuit designations should be identified during the planning/DD 1391 development process. Unless indicated otherwise, each critical panel in ATC Facilities must be 3-phase, 100 Amperes (A) with a 100A 3-phase shunt trip main breaker.

Flush mount panels in the ATC equipment spaces are required, except on masonry walls. Provide six (6) 3/4-inch (20-mm) empty spare conduits to a NEMA 3 enclosure below the RAF at each panel. These spare conduits will facilitate adding circuits in the future without exposing the bottom of the panel.

Each of the Critical power panels must be fed individually from the CPDS. The feeder to each 100 A critical panel must be designed for 100A 3-phase of load at rated voltage. The desired locations of the Critical power panels will be determined during design. Power panels must retain sufficient access for the future installation of additional conduits.

3-7.5 Non-Critical Power Panels.

Non-critical panels are required in ATC Facilities to support general facility requirements, such as overhead lighting and general-use duplex outlets. Desired locations for these power panels will be identified during design.

Non-critical power panels are typically located adjacent to the critical power panels.

3-7.6 Power Panel Access.

The individual room designs must ensure that there are no objects or equipment mounted above or below power panels. This will ensure nothing impairs the installation of conduit runs to support equipment being installed after construction.

Post-construction access to power panels must be designed into the facility. When a power panel is located above the RAF, there must be sufficient cable paths (conduit or 4-inch (100-mm) x 4-inch (100-mm) metal duct) to facilitate cable installation. When power panels are located in adjacent rooms to where the service is required, an adequate number of conduits must be installed from the panel to the room(s) serviced. Quantities and termination of additional cable paths should be specified during the planning process.

3-7.7 Critical Power Circuits

ATC equipment power circuits must be installed during construction. The circuits terminate in junction boxes below the RAF. During the equipment installation, the circuits are extended to the equipment. Everything installed under the RAF (except ATC circuit cables) is installed during construction. This places the burden of overcoming interference issues on the construction contractor.

Note: Not all junction boxes will require an individual conduit path to the Critical power panel. However, conduit sizes and junction boxes must conform to the NEC with respect to the fill requirements. Wiring and junction boxes must be labeled with the power panel designation and circuit number. Spare and unused circuits may be used in the future.

3-7.8 Exterior Electrical Outlets.

Any requirements for vehicle heater outlets or golf cart charging stations should be determined during the planning process. Watertight outlets may be provided for vehicle heaters in parking lots at cold weather sites or for golf cart charging stations when authorized by the local installation.

3-7.9 Neutral Conductor.

Every circuit should consist of one phase conductor, one neutral and one equipment ground. Up to three (3) circuits may be run in one raceway.

3-8 TELECOMMUNICATIONS.

3-8.1 General.

Administrative telephone wiring/cabling must be installed under the MILCON project and funded with MILCON appropriations. In addition, specialized communication wiring/cabling between facilities (e.g., cabling which extends from the ATCT to the RACF, navigation aids, remote transmitters and receivers, etc.) and all raceways, conduits, pullboxes, duct banks, etc., are considered permanent and must be installed as part of the construction contract.

The construction contractor must provide all Inside Plant (ISP) and Outside Plant (OSP) equipment for the facility. ISP includes outlets, jacks, cabling, conduit, cable trays, racks, cabinets, building protector assemblies, and passive termination devices such as patch panels and connector blocks. OSP includes exterior cabling, ductbanks, manholes and utility poles.

3-8.2 Operational Telephone Lines.

Administrative telephone service, not related to ATC, will be required in the ATC and Air Operations Facilities. Typically, this service includes dedicated lines for point-to-point communications (e.g. Crash Phone). Consult with local ATC personnel for guidance. As a preliminary recommendation, each room should have a minimum of one administrative telephone line.

3-8.3 Data Communication Lines.

Communications networking cable should be installed in each space and must be of a type consistent with current station or networking systems. Consult with local ATC personnel for guidance. As a preliminary recommendation, two network lines should be available in each space.

Two data ports are generally required at each location, one for a computer and one for a printer. Four outlet panels (Type RJ-45) are recommended for network and telephone services in each room. Exact requirements must be coordinated with local Facilities, Communications and Information Technology personnel.

3-8.4 Telecommunications Room.

Telecommunications Rooms for Telephone/Data communications systems must be provided for all ATC and Air Operations Facilities. This room is configured with termination blocks and patching hardware and serves as the communications distribution plant for the building supported. This room may require temperature and humidity control. The design must be coordinated with local Facilities personnel, and designed to accommodate all telecommunications and networking equipment.

Provide fireproof 3/4-inch (20-mm) thick plywood from floor to ceiling for telecommunication mounted equipment. Paint plywood to match the other walls in the facility. Provide Building Entrance Terminals (BETs) for the primary lightning protection at their entry point into this room and as necessary to meet the NEC. The BETs may be mounted horizontally or vertically. If mounted vertically, there must be 12 inches (300 mm) minimum between each BET. This will allow external cabling to be connected properly.

A cable management system must be used to create a neat, professional cable installation. Attention to detail is critical. Organize space on walls for each cable type and service. Provide space as necessary in the MDF for other services controlled by other factions (such as CATV and fire alarm systems). It may be necessary to design alternate security for each faction in this room.

3-8.5 Facility Main Distribution Frame.

The facility Main Distribution Frame (MDF) is the location in the facility where all exterior signal cabling (not power) is terminated and surge suppressed before being distributed throughout the facility. The types of conductors include (but are not limited to) telecommunications copper, communications fiber, control circuits for airfield lighting, CATV coaxial cabling, and ATC equipment circuits. The contractor is required to remove all waterproofing from exposed conductors. There must not be another room or communications closet within the ATC Facility for termination of outside plant services. This room may require temperature and humidity control. Coordinate with Mechanical Engineer on HVAC requirements for this room.

The MDF must be located in the Telecommunication Room and must be designed with a minimum spare capacity of 25 percent. A short circuit calculation and protective device coordination analysis for the entire facility must be accomplished to determine the appropriate available interrupting current capacity (AIC) requirement for all facility panels and breakers. This analysis must be performed in accordance with FAA Order 6950.27, *Short Circuit Analysis and Protective Device Coordination Study*. The design must allow only the over-current device closest to the fault to operate.

An elevation drawing of the MDF area must be included in the design showing the location of all installed components in this area, to include (but are not limited to): BETs, inter-site conduits, fiber and copper terminations.

3-8.6 Data Cable Tray.

All cable trays must be the dual flange type with a fill depth of at least 4 inches (100 mm) for electronic and telephone cabling and equipment. The cable trays must be designed

to provide shielding consistent with equipment cabling requirements, FAA-STD-019e, and must be UL listed. The system design must be coordinated with specific equipment layouts as directed by the designated Electronics Engineer. Cable trays must not be located in fire rated corridors. Cable trays must be easily accessible for maintenance. Where feasible, cable tray installations must provide one foot of access between trays and three feet of access around trays. Cable trays must be bonded in accordance with FAA-STD-019e.

Design engineers must consult with each other to ensure that the cable tray does not interfere with other requirements. Designs for cable tray routing must ensure that the tray lies horizontally flat and is not mounted sideways on the tray edge.

3-8.7 Communications Outlets.

One Quad communications outlet is required every 100 square feet. A minimum of one outlet per quad is used for voice circuit.

Multiple outlets should be installed in every room. Installing wiring and multiple outlets within a room adds flexibility for future requirements.

Printers, fax machines and other similar electronics require a separate, dedicated communications outlet.

3-8.8 Telephone Outlets.

Telephone outlets are required in the offices of the facility. Provide a minimum of four (4) each (one per wall) "quad" jacks, two each CAT 6 data and two each CAT 6 telephone at each room. Conduit for telephones can be stubbed, with bushings provided, above the ceiling where suspended ceilings are used. A cable tray should run from the Telephone Terminal Backboard (TTB) to and along the centerline of the facility when this method of installation is used. Conduit is only necessary for areas where there is no ceiling or there is no access above the ceiling. When conduit is used, it must be prewired.

3-8.9 Internal Facility Connectivity.

Careful attention must be applied when designing cable access runs within ATC and Air Operations Facilities to ensure pathways are uninterrupted, provide accessibility along the routes, and provide enough clearance for feeding the cables from point of origin to point of terminations using industry standards.

3-8.10 Inter-Site Connectivity.

ATC remote facilities (navigational aids) are located on and off the airfield, and most require hard-wire connectivity back to the ATC and Air Operations Facilities. These inter-site conduits can be expensive to install, especially if the path is under runways,

taxiways, or parking aprons. All conduits entering the facility must comply with FAA STD-019e.

- All inter-site cabling must be terminated utilizing the Western Electric color code. Provide detectable warning tape above any new duct banks installed for electronic detection.
- Where new facilities are proposed to replace existing ATC Facilities, the new ATC Facilities will require connectivity to the same remote sites as the existing ATC Facilities. This new connectivity must terminate at the RACF MDF. If existing facilities are to be demolished, the design must reroute any “through” cabling prior to the entry into these facilities. Splicing and burying cables beneath the demolished structures is not acceptable. There must be direct and unobstructed access between the vertical cable ladder and the inter-site cable trays/ducts, which provide connectivity to ATC systems in the other ATC facilities.
- If flooding is a possible issue, the conduits may require extensions so that water will not discharge into the ATCF. The penetration in the ATCF must be near the location of the MDF. Nylon pull-cords are required in all conduits. Manhole or conduit access requirements must be determined when the ATCF locations are finalized. A combination of copper, fiber optic, and coaxial cables, with sufficient spares for future use, must be installed. A dedicated ATC-related inter-site trunk cable (minimum 300 pair) is required between the new RACF and ATCT and the existing ATC facility.
- Existing inter-site connectivity may be utilized. However, any existing connectivity cannot be removed or interrupted.
- Every attempt must be made to minimize splices in all new copper and fiber inter-site cabling. Any splices required in the inter-site cabling must be installed by properly trained personnel. All fiber cables must be fusion spliced. All splices, copper and fiber, must be the direct bury, encapsulated, re-enterable type.
- All conduits must penetrate the RACF and ATCT so that installed communications cables can transition easily to their associated termination area or enclosure. The exact termination of the conduits will be determined during design.
- Any connectivity requirements to Flight Planning, the Weather Office, or Airfield Lighting Vaults should be identified during the planning/DD 1391 development process.
- LAN or telephone cabling must not be placed in the same cable tray or conduits as ATC circuits.

Site specific requirements for communication ducts, conduits, manholes, and stub-outs should be identified during the planning/DD 1391 development process.

3-9 PHYSICAL SECURITY.

Physical Security is defined as that part of security concerned with physical measures designed to safeguard personnel, to prevent unauthorized access to equipment,

installations, material, and documents, and to safeguard them against espionage, sabotage, damage, and theft.

3-9.1 General Requirements.

In the context of these requirements, facilities may be sited within a restricted or controlled area (airfield enclave) or may be designated as a controlled or restricted area. Controlled and restricted areas are defined areas in which there are special restrictive measures employed to prevent unauthorized entry. Restrictive areas may be of different types depending on the nature and varying degree of importance of the protected asset. Restricted areas must be authorized by the installation commander, and properly posted, and shall employ physical security measures.

3-9.2 Specific Requirements.

All planned security design and installation must be coordinated in advance with the Base Antiterrorism Office (ATO), Security Officer, and Air Operations to determine the area or building designation (controlled or restricted), threat environment, design basis threat (DBT), level of protection, and access control or other ESS requirements. Use the process in UFC 4-020-01 to identify the design criteria, which includes the assets to be protected, the DBT, and the levels of protection. The engineering risk analysis conducted as part of UFC 4-020-01 should be consistent with the terrorism risk analysis conducted by the installation security/AT staff.

3-9.3 Electronic Security Systems.

Design electronic security systems (ESS) when required in UFC 4-021-02, *Security Engineering: Electronic Security Systems*.

3-9.4 Security Lighting.

Design all security lighting to meet the requirements as stated in UFC 3-530-01, *Design: Interior Exterior Lighting and Controls*.

3-10 SITE WORK.

3-10.1 Parking.

Provide parking spaces for staff on shift, plus accessible spaces required by ABAAS, two visitor spaces, and government vehicles as needed. Many airfields have alternative vehicles for Government use. Provisions for these vehicles including charging stations must be considered. Additional parking should be considered for shift changes. Specific criteria are given in UFC 3-210-02, *POV Site Circulation and Parking*.

3-10.2 Pavement Design.

Exterior paved areas include aircraft, pedestrian and vehicle access and parking. Vehicle access and parking should be in accordance with UFC 3-250-01FA, *Pavement Design for Roads, Streets, Walks, and Open Storage Areas*.

3-10.3 Site Utilities.

Reference UFC 3-210-01A, *Area Planning, Site Planning and Design*; UFC 3-210-06A, *Site Planning and Design*; and UFC 3-230-04A, *Water Distribution*.

3-10.4 Site Lighting.

Orient exterior fixtures to minimize glare on ramps and taxiways. Use full cut-off type fixtures. Refer to UFC 3-260-01, *Airfield and Heliport Planning and Design* for clearance requirements, obstruction lighting requirements, and airfield utility lighting information.

3-11 SAFETY AND HEALTH.

3-11.1 General Requirements.

Design occupied buildings with maximum consideration given to safety and health, with particular emphasis on noise control for hearing conservation.

3-11.2 Human Engineering.

Consider safety in relation to operational function, accessibility for maintenance and repair, physical layout for traffic, interface with other equipment, and environmental factors, such as lighting, temperature, and humidity. See MIL-STD-882, *Standard Practice for System Safety*, and MIL-STD-1472, *Human Engineering*.

3-11.3 Electromagnetic Hazards.

ATC and Air Operations facilities contain equipment that radiates an electromagnetic signal. Consider the effect of electromagnetic radiation (EMR) on personnel (HERP), ordnance (HERO) and fuel (HERF) when planning and designing facilities housing EMR emitting equipment. Provide safety measures to eliminate or reduce hazardous conditions. Refer to Section 2-6.2 and MIL-HDBK-1012/1, *Electronic Facilities Engineering*.

3-11.4 Life Safety.

All drawings must be reviewed by the Regional Safety Manager for safety issues such as lockout points, anchor points, confined spaces, fall hazards, noise hazard areas, and areas where eyewash stations or emergency showers may be necessary. These issues must be addressed at the design level to minimize hazards involved with the day-to-day activities and maintenance of the facility.

This Page Intentionally Left Blank

CHAPTER 4 SPECIAL DESIGN REQUIREMENTS

This chapter describes the special design requirements that only apply to each type of Air Traffic Control and Air Operations Facility, including:

- Air Traffic Control Tower (ATCT). Section 4-1
- Radar Approach Control Facility (RACF, referred to as ARAC (Army), RATCF (Navy) and RAPCON (Air Force)). Section 4-2
- Air Operations Building (AOB, referred to as Air Operations Building (Navy), Airfield Management Operations (AMOPS) Building (Air Force) or Airfield Headquarters Facility (Army)). Section 4-3

4-1 AIR TRAFFIC CONTROL TOWER (ATCT).

Design the Air Traffic Control Tower (ATCT) to be generally consistent with FAA Order 6480.7e, *Airport Traffic Control and Terminal Radar Approach Control Facility Design Guidelines*. If a conflict exists between this UFC and FAA Order 6480.7e, this UFC governs. Sizing of Control Cab window mullions, Cab glazing and electrical grounding are examples of where most recent FAA criteria should be considered.

4-1.1 General Requirements.

4-1.1.1 Risk Category.

For Risk Category, see Table 2-2, UFC 3-301-01. This classification has an impact on the design of most design disciplines involved with an ATCT, including architecture and structural, mechanical, electrical and fire protection engineering. Ensure that non-structural components (e.g. raised access flooring, architectural components, utilities, etc.) are laterally braced as required for seismic load stability in accordance with UFC and building code provisions. Careful analysis of these requirements must be addressed in the planning/DD 1391 development phase. Coordinate additional bracing requirements to avoid interference with items to be installed post construction, such as cabling, conduit raceways and other infrastructure for electronic equipment.

4-1.1.2 Airfield and Ramp Blind Spot Monitoring.

If any portion of the airfield surface is actively used for aircraft movement or parking and the visibility from the ATCT is limited, Closed Circuit Television (CCTV) may be required to provide remote viewing of the area. Consult with the local ATC operations personnel for specific requirements. The entire runway surface must be visible. CCTV cameras must not be used for remote viewing of runways.

4-1.2 Architectural Requirements.

4-1.2.1 Accessibility for the Disabled.

In air traffic control towers, an accessible route is not required to serve the cab and the floor immediately below the cab. See ABAAS F206.2.3.

4-1.2.2 Raised Access Flooring.

Provide Raised Access Flooring (RAF) in the Control Cab with 18 inches (450 mm) of clearance between the floor panels and sub floor to accommodate wiring and insulated piping. The use of RAF in the ATCT Cab area is required to facilitate the periodic rearranging and upgrading of equipment and cables.

The RAF in the Cab must be supported around the perimeter in addition to the normal stringer support. Due to the shape of the Cab, some pieces of RAF can be small, odd shapes. These small pieces must be securely supported so that when stepped on, they do not create a safety hazard.

4-1.2.3 Floor Finishes.

Provide floor tiles with integral, static dissipative carpet coverings in the Control Cab. The use of carpet aids in sound dampening.

4-1.2.4 Interior Walls.

Use wall materials that will help with sound attenuation in the Control Cab and Cab access stairway.

The finish of any interior exposed wall surface in the Cab must be a dark, flat, non-reflective color to reduce night glare. Consult with local ATC personnel for color preferences.

4-1.2.5 Control Cab Walls.

The exposed Control Cab wall above the window and below the window sill must be finished with acoustical material, such as a heavy-gauge insulated metal panel with noise absorbent backing. Design decibel level no greater than 65 dB. Use of floor carpet on walls is not allowed.

4-1.2.6 Ceiling Finishes.

The Control Cab ceiling must be accessible acoustical ceiling tiles with low light reflectance in a suspended grid system. Use dark colored tiles with textured surface, and high acoustic damping. Flat black color is preferred to prevent reflections on the Cab windows. Suspended ceiling grids must be painted flat black.

Ceiling tiles must be constructed of material which is dyed black, so that the ceiling tiles are black throughout the entire tile. The grid system should not be painted black on site. The grid should be ordered from the manufacturer as black.

4-1.2.7 Ceiling/Clearance Heights.

The minimum clear height in the ATCT from the finished floor to the bottom of a finished ceiling must be 8'-0", except for the following conditions:

- Control Cab must have a clear ceiling height of 10'-0" above worker floor (not the raised supervisor level).

- Electronic Equipment Rooms must have a minimum clear unobstructed area from the finished floor to any overhead obstruction of 9'-2". These rooms do not typically have a finished ceiling installed. Refer to Figure 4-1 below for more information.

Figure 4-1 Electronic Equipment Room Clearance Detail

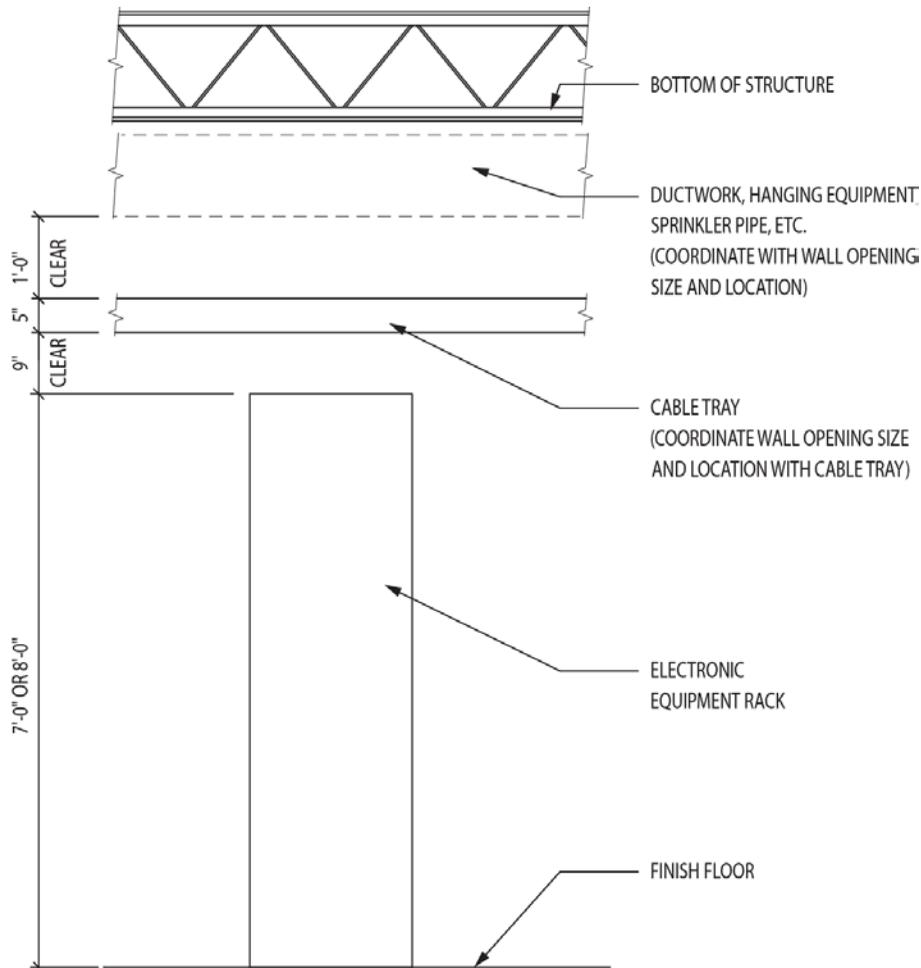

The structural height (floor-to-floor) of each level should be enough to allow HVAC, sprinklers, and electrical equipment be installed without interference.

4-1.2.8 Windows.

Windows must be provided on all sides of the Control Cab, and may also be required in other spaces in the tower.

Window ledges in the Cab must be designed so as not to hinder an air traffic controller's ability to see aircraft movement areas. Deep window ledges extend control consoles away from windows and prevent controllers from viewing aircraft movement areas below and in close proximity to the ATCT. For this reason, the window sill wall thickness/depth must be as narrow as possible (no more than 18" deep).

- The ATCT window sill must be coordinated with the Cab consoles so that the sill and the consoles are the same height. The window sill height must be consistent at the entire Cab perimeter where the consoles will be installed. Refer to Figure 2-3 for window sill height and Cab console height details.
- The window sill must be capable of supporting a 250 lb point load for personnel standing on the sill for maintenance and repair purposes. All window sills and mullions must be covered with a laminate or other material to provide a durable, non-reflective surface. Materials such as gypsum board, plywood, or stained or painted wood are not acceptable.
- The length of the screws used to secure the cab window frames to the structure must be kept as short as possible. If the screws are too long, installing flexible non-metallic tubing or cables inside the tubular column is difficult.
- At a minimum, provide a single window on the runway side of the shaft tower in Training/Briefing Rooms and in the Chief Controller's office. Provide more windows if structurally feasible.

4-1.2.9 Control Cab Glass.

Control Cab glass is the glass in the windows of the Cab for observation of aircraft. Cab glass must be low-iron glass to optimize visible light transmittance. Tinted glass or heat strengthened glass must not be used for the Cab glass.

- Low-E coated glass may be used with the understanding that the coating may reduce visible transmittance. Coordination with HVAC design must take place during planning and design phases to determine the acceptable heat transmission for the low-E coated glass.
- The Cab glass must slope at an outward angle of 15 degrees from vertical.
- Use double pane glazing unless design conditions dictate otherwise.
- Window units must be constructed with a metal or composite plastic perimeter or a unitized extruded aluminum system frame. The frame must be bonded to the glass to provide an airtight, waterproof, and vapor proof seal.
- Cab glass must meet site-specific wind load and seismic requirements.
- Cab glass must allow light gun red, white and green light from inside the ATCT to the outside.

Coordinate with mechanical engineer on HVAC design to minimize condensation forming on Cab glazing, using humidity controls and attention to return air ducts adjacent to each side of the Cab. Cab glass must meet the requirements of the UFGS 08 88 58, *Air Traffic Control Tower Cab Glazing*.

4-1.2.10 Control Cab Window Mullions.

Minimize Control Cab window mullions for air traffic controller visibility. Window mullions should not be directly in the line of sight to critical aircraft movement areas such as the approach ends of the runways.

- If located in a high-wind zone, additional intermediate window mullions may be required to transfer glazing loads to the structure. These mullions, used to resist wind and seismic forces, may be considered only as a last resort.
- Cab window mullions are not limited to aluminum. There are innovations in steel mullion systems that are commercially available. The steel system has better design load properties than aluminum. Also, the coefficient of expansion is less (stainless steel has less thermal conductance than aluminum).
- To minimize sun reflections and hindrance of night vision, Cab window mullion and column finishes must be a non-reflective dark color, and must incorporate a high performance anti-corrosion protection coating. Particular attention must be paid to prevent sunlight reflections from the window sills and mullions. Consider butt glazing in place of non-load bearing mullions.

4-1.2.11 Control Cab Window Shades.

Provide manually-operated window shades for the Control Cab windows. Refer to FAA-E-2470b, *Transparent Plastic Window Shades* and FAA-ANI-300-380, *Transparent Plastic Window Shades*. The Cab shades must be at least 0.125 mm thick, color smoke gray, body dyed, supported by rollers with constant tension. Follow slope of windows and match size and shape of Cab windows. Manual operation is preferred - electric rollers are not encouraged. "Mini-blinds" or opaque, semi-opaque, or mesh type shades are prohibited. Design suspended ceiling so window shade roller is recessed in ceiling.

Local ATC personnel must determine if dual shades are required. If required, use a dual shade system with F-72 SR as the primary shade material and DS 8 SR as the secondary shade material.

4-1.2.12 Roof.

- The Control Cab roof must be sloped to drain away from the center; however, the slope must be kept to a minimum as maintenance personnel will be walking and working on the roof to maintain antennas. Walking pads are required on the Cab roof to protect the roofing material. These pads must provide a walking surface around the perimeter of the roof as well as a path from the perimeter to the roof hatch. Provide a place on the Cab roof to stand while safely shoveling snow away.

- It is recommended that the Cab roof be a flat thermoplastic roof with a Solar Reflective Index (SRI) of 78 or better to meet LEED “cool roof” requirements. Use a light color roof membrane to help achieve LEED criteria. No shingles are allowed. Minimize roof dripping at Cab windows to the greatest extent practicable.
- An OSHA-compliant industrial type safety railing (top rail, middle rail & kick plate) or a parapet wall with height to meet OSHA requirements is required on the roof. The 4-inch (100-mm) sphere rule does not apply to the railing system on the Cab roof because it is considered a “maintenance area” and the railing should comply with the regulations for maintenance areas. Coordinate railing shape and size with antenna mounting requirements.
- Antennas will be mounted to the railing and it shall be designed to carry the weight of the antennas. If a parapet wall is provided, a railing system is still required on the inside of the parapet wall for mounting antennas.

4-1.2.13 Roof Access Hatch.

A personnel access hatch and ladder/stairs is required to transit from the Control Cab to the roof. The opening between the suspended ceiling and the roof is required to be enclosed around the hatch opening and painted flat black on the inside. The portion of the hatch which is visible when stowed must also be painted flat black.

The access hatch must be provided with a concealed pull-down/retractable ladder with integral grab rail. Include OSHA-compliant railing and gate at roof access hatch.

The location of the roof hatch and ladder must not be over the controller position cabinetry. Additionally, it is essential that the location of where the roof ladder will bear on the raised access flooring be shown on the design drawings. This will confirm that the extended ladder does not interfere with the controller position cabinetry. The bearing feet of the ladder must rest on the finished floor when the ladder is fully extended.

4-1.2.14 Catwalk.

Provide safe access for walking around the exterior of the Control Cab to facilitate exterior observations, window washing, and general maintenance. The width of the catwalk must be selected to ensure that it does not interfere with the air traffic controller’s visibility of the runway, taxiway, or apron areas. Locate the catwalk at a sufficient elevation below the Cab to permit the controllers a view of the field unobstructed by any railing. A concrete catwalk is preferred. The exterior catwalk can be a galvanized metal or aluminum grate that allows snow to melt directly through without building up at the edge. Corrosion issues must be taken into account if metal grating is used. Care must be taken during the design to eliminate the possibility of falling snow or ice from the catwalk.

Provide a weather-sealed access door to the catwalk from the ATCT Stairwell. The door must be a minimum of 32 inches (810 mm) wide and 36 inches (910 mm) high. The head of the door must not extend above the cab sill and the base of the door must not extend below the cab walkway extension. The height of this door is limited due to the Cab structure, but must be as tall as possible. Personnel access to the ATCT catwalk is

required to allow washing of the exterior glass of the Cab without the need for a safety harness. Consult with the local ATC staff to discuss window cleaning methods and requirements.

The catwalk must be designed to meet ANSI and OSHA requirements, and should be wide enough to allow the windows to be washed without having to lean backwards over the railing. Catwalk guardrails must also meet ANSI and OSHA requirements, but are not designed to support antennas or other equipment.

4-1.2.15 Elevator.

For Army and Navy projects, comply with NAVFAC ITG 2013-01 *NAVFAC Elevator Design Guide* in addition to requirements below.

Provide an elevator in the ATCT. The elevator must operate from the ground floor to the floor below the floor directly below the Control Cab, or the floor below the Cab if possible.

A hydraulic elevator is acceptable if the Tower Control Cab floor level is less than 60 feet above grade. Otherwise, provide an electric traction elevator. Electric traction elevators must have elevator machine room with elevator machine and controller in a machine room. Elevator machine room may be located above or adjacent to the elevator hoistway.

- Elevator speed must be 150 feet per minute (fpm) if hydraulic, and 350 fpm if electric traction. Minimum rated load for a typical elevator must be 3500 lbs. Elevator capacity must be sufficient to transport equipment to be installed above the ground floor.
- Elevators must conform to ASME/ANSI A17.1, *Safety Code for Elevators and Escalators*, as well as the International Building Code (IBC), NFPA 101, and NEC. The ATCT elevator must be available for use on standby power.
- The elevator car must be sized to accommodate the stretcher requirements of IBC Chapter 30 (24 inches x 84 inches or 610 mm x 2130 mm). The recommended interior size of the elevator car must be 60 inches (1520 mm) wide x 84 inches (2130 mm) deep x 108 inches (2740 mm) high.
- The elevator car door opening must be at least 42 inches (1060 mm) wide and 84 inches (2130 mm) high. The elevator car door must be the single-speed, side-opening, horizontal sliding type. The elevator car must have retractable covers.
- Provide a ventilated elevator shaft.
- Elevator doors must not open directly to the ATCT Stairwell enclosure.
- Hydraulic elevators must be equipped with elevator car safeties and an overspeed governor. Position of the overspeed governor in the elevator hoistway must allow for a governor access door accessible inside the ATCT. Governor access must include a working platform with a platform height of 4 ft. below the bottom of the access door.

4-1.2.16 ATCT Stairwell and Control Cab Stairway.

A pressurized stairwell is required from the floor below the Control Cab to the ground floor. Stair width must be 44 inches (1120 mm) minimum.

A stairway from the floor below the Cab leading up into the Cab must be provided. This stairway must not be a ship's ladder-type stair, but must be a regular stairway meeting all applicable design codes. Code-compliant stairs are required from the Cab subfloor to the RAF. Care must be taken so that the stairwell does not take up a large portion of the Cab floor area.

4-1.2.17 Vertical Utility Chase.

4-1.2.17.1 Ground-to-Cab Mechanical Chase.

A fire-rated chase, open from the ground floor to the concrete sub-floor of the Control Cab that serves as a pathway for HVAC and plumbing utilities from the Tower Shaft Mechanical Room to the ATCT Mechanical Room.

4-1.2.17.2 Ground-to-Cab Vertical Cable Chase.

The ATCT Vertical Cable Chase is typically a 4-foot wide x 2-foot deep (clear inside dimensions) fire-rated chase, open from the ground floor to the concrete sub-floor of the Control Cab.

- A vertical ladder-type cable tray is required for ATC equipment cabling. This vertical cable tray must be accessible from all floors and must provide cable access from the first floor to the open area beneath the ATCT Cab RAF. The ladder must be centered on the chase access door. A minimum 18 inches (450 mm) wide x 4 inches (100 mm) deep (fill depth) ladder-type cable tray is required to provide a cable management system surface. Additional information for the vertical tray shall be provided during design.
- All power cables in the chase must be located in rigid metal conduit instead of the cable tray.
- Access between the top of the vertical cable chase and the Cab is provided as conduit stubs through the Cab sub-floor. Six stubs of 4-inch (100-mm) inside diameter (ID) conduit are required for the exclusive use of ATC equipment cabling. These stubs must be furnished with anti-chafing bushings on each end and must extend at least 4 inches (100 mm), but no more than 6 inches (150 mm), above and below the sub-floor. Additional conduit may be required for telephone and Local Area Network (LAN) cabling. Consult with local ATC operations personnel to confirm final requirements.
- Lockable access to the vertical cable chase must be designed into each floor of the structure. The design must provide sufficient opening to allow personnel to reach and dress cabling runs on the tray. Signs/labels stating "Cable Chase" must be provided for each cable chase access and match in style and size the other facility labels/signage.

- A full size door is not required at each level of the tower for access. A full size door is required on the ground floor and the equipment room floors. Access on the other floors can be via a 24-inch (610-mm) wide X 36-inch (910-mm) high fire-rated access panel/door. If there is no floor at a particular level of the ATCT, an access walkway is required from the stairwell to the front of the cable chase. Final door size will be determined during design.
- A wall opening 5 inches (125 mm) high x 14 inches (350 mm) wide must be provided for the cable tray that will connect the vertical cable tray to the suspended tray systems in the ATC Electronic Equipment Room(s). This opening must be centered above the lockable access door. The bottom of the opening must be a minimum of 110 inches (2790 mm) above the finished floor. Ensure openings comply with fire codes. The final location of this opening will be identified during design. The opening must be finished with smooth edges on both sides of the opening between the chase and equipment space and on the sides of the opening. This opening must be finished to match other openings in the walls, such as sheetrock, paint, and trim.
- Cable Separation. Power and communication cables must be physically separated by distance or by barrier to preclude power cables from coming into contact with communication cables in accordance with the NEC. Cable ladders must be provided. Vertical shafts must be provided with fire separation assemblies in accordance with the other paragraphs in this section.
- The vertical cable chase must be located so as to minimize cable distance to the ATC equipment space(s).

4-1.2.17.1 Control Cab-to-Roof Vertical Chase.

The path for all the RF cables to the roof must be through or adjacent to the tubular steel columns supporting the Control Cab roof. These cableways provide the means to run signal and antenna cables from beneath the Cab RAF to the area above the suspended ceiling and/or to the roof. Power cables for obstruction lights and any building system wiring (electrical and telecommunications) located above the ceiling or on the roof must pass through only the two (2) cableways at the back of the Cab near the Cab stairway. The cableways near the stairs are typically not accessible after construction is complete. All remaining cableways must be reserved for the ATC antenna and signal cabling.

These cableways must be free of obstructions. Cableways must be provided with nylon pull-cords and pull boxes on each floor, sized per the NEC. Pull boxes must be large enough to meet the minimum bending radius specifications of any transmission lines running to the roof. All cable paths must be free of burrs and sharp edges that would damage cables.

- **Army and Air Force:** Provide ducts within the Cab for ATC equipment cabling. Two (2) 4-inch (100 mm) Inside Diameter (ID) ducts must be provided for antenna cables between the ATC Equipment Room and the roof. These ducts are installed adjacent to the roof support columns and terminate in weatherheads on the roof. Ducts from the ATC Equipment Room extend to the floor just below the Cab. A ladder-type cable tray connects these ducts to two (2) 4-inch (100 mm) ID ducts

that continue the run up to the weatherheads required at each of the Cab roof corners. Refer to Figure 4-2 for Plan Detail at Control Cab Window Mullion/Structural Column (Army and Air Force only).

- **Navy:** Access cutouts in the vertical columns are required below the Cab RAF and above the suspended ceiling area. These cutouts are typically slots of at least 2-1/2 inches (62 mm) x 6 inches (150 mm), opening directly into the columns. Reinforcement of these access holes may be required to maintain the structural integrity of the columns. The bottom of the slots below the RAF must be 2 inches (50 mm) to 6 inches (150 mm) above the sub-floor.
- The preferred location of the openings is on the surface of the column that faces the inside of the Cab. However, access holes on the sides of the column are acceptable. The primary requirement is for the access holes to accommodate two sleeves for antenna cables with a bend radius of up to 10 inches (250 mm). Clear access to these openings must be maintained. Nothing must be allowed to block access to these openings, such as HVAC ductwork.

A minimum of two (2) 2-inch (50-mm) ID smooth-walled, non-metallic, flexible sleeves/conduits must be installed in each of the mullions with enclosed structural column to provide a continuous path through the columns. These sleeves are for the exclusive use by SPAWAR Atlantic. One end of each sleeve must be terminated three (3) feet into the cable tray beneath the RAF and secured to the tray. The other end of each sleeve must terminate in the space above the suspended ceiling, within 6 inches (150 mm) of the weatherhead conduits in the same column area, and the ends secured. In addition to the two sleeves described above, one (1) 2-inch (50-mm) ID flexible sleeve must be installed in the column closest to the position labeled as "Local" in the FRS. One end of this sleeve must lay three (3) feet into the cable tray beneath the RAF. The other end must terminate in the area above the ceiling. Each end must be secured to prevent accidental movement into inaccessible areas. The column location for this sleeve will be identified in the FRS.

An ATCT with two local positions will require one conduit for each local position. The requirement for two sleeves or tubing will be identified in the FRS.

After the finished wall is installed in the Cab, access to the cutouts in the column below the RAF must be provided. Where drywall or other wall covering is installed, there must be approximately 6-inch (150-mm) x 6-inch (150-mm) openings provided to permit reaching the access holes in the columns. Protective flashing must be installed to prevent chipping the wall material during post-construction cable installation.

One (1) 4-inch (100-mm) ID galvanized conduit and weather head is required at each of the Cab roof corners. These conduits must be welded to the roof structure and must extend 18 inches (450 mm) to 24 inches (610 mm) above the roof and 8 inches (200 mm) below the roof structure into the space above the suspended ceiling. Anti-chafing bushings area required

on the end of the conduit below the roof. The weatherhead must be galvanized with stainless steel hardware, and sized to accommodate cables with a minimum bending radius of 11-1/4 inches (285 mm). Refer to Figure 4-3 for Plan Detail at Control Cab Window Mullion/Structural Column (Navy only).

Figure 4-2 Plan Detail at Control Cab Window Mullion and Structural Column (Army and Air Force only)

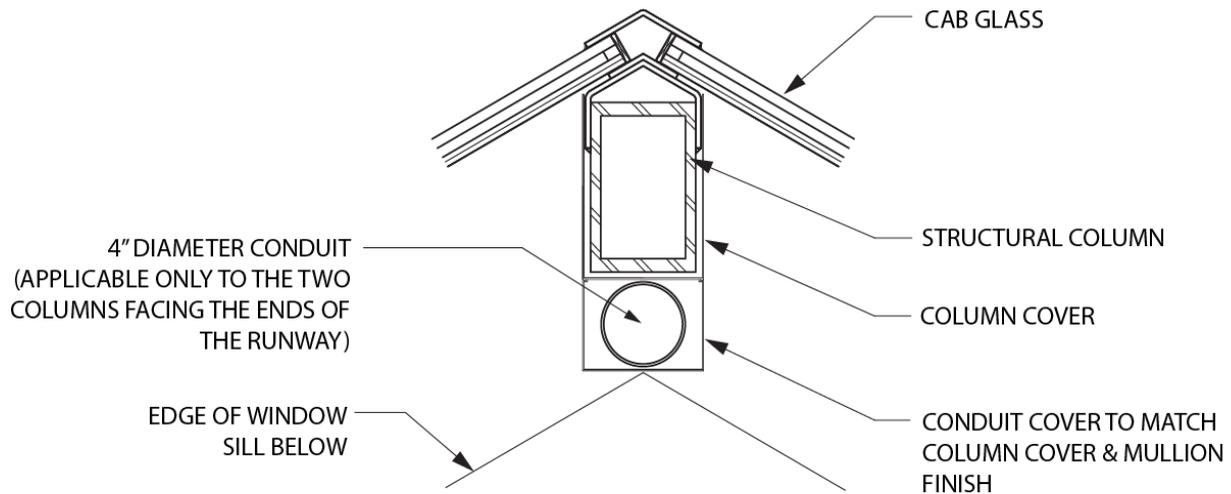
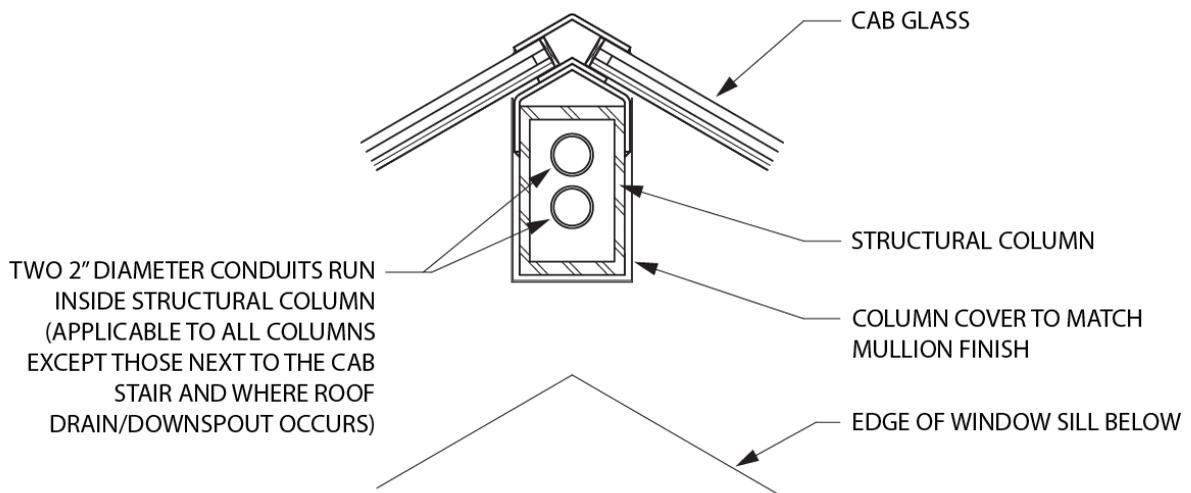

Figure 4-3 Plan Detail at Control Cab Window Mullion and Structural Column (Navy)



4-1.2.18 Cable Tray System.

In the Control Cab, an aluminum or steel ladder-type cable tray is required beneath the RAF, near the controller consoles, and connected to the vertical cable chase. The consoles will be located flush against the Cab wall. This cable tray must be 12 inches (300 mm) wide and 4 inches (100 mm) high (fill depth), with 6-inch (150-mm) on-center rung spacing, and must be installed flush with the front edge of the controller position cabinets. The tray must run continuously around the front of the ATCT Cab and mounted on 1-5/8 inch (40 mm) struts, secured to the concrete floor. The exact location of this cable tray will be determined during design.

In the ATCT Electronic Equipment Rooms, an aluminum or steel ladder-type suspended cable tray system is required. This cable tray must be 12 inches (300 mm) wide and 4 inches (100 mm) high (fill depth), with 6-inch (150-mm) on-center rung spacing. This tray must start at the opening above the access door to the vertical cable ladder and extend into the room above the electronic equipment cabinets. The bottom of the cable tray system must be at least 110 inches (9'-2" or 2790 mm) above the finished floor. If a suspended ceiling is installed, a minimum clearance of 12 inches (300 mm) must be provided between the top of the cable tray and the ceiling. Cable tray dividers, sized to fit the tray, must be provided. The dividers must be MILCON provided and installed by the Government. The location dimensions of the cable tray must be shown on the electrical design drawings to ensure the tray is installed in the correct location.

- **NOTE:** The specific design of the ATCT Electronic Equipment Rooms will determine the exact layout of the cable tray. The exact location of the electronic equipment cabinets and the cable tray must be determined during design.

4-1.2.19 Doors.

ATCT ground level entrance requires a minimum 42" (1070 mm) wide opening.

The doors to the ATCT Electronic Equipment Rooms must be a minimum of 36 inches (910 mm) wide x 80 inches (2030 mm) high to allow for the movement of electronic equipment racks and other ATC equipment. Equipment room doors must have closers and be lockable.

4-1.2.20 Control Cab Consoles.

- **Navy:** The Cab position consoles will be designed, procured and installed by SPAWAR Atlantic during the equipment installation.
- **Army/Air Force:** Use prefabricated modular consoles, vented type with flat top and/or slope top capability with solid surface extended shelf. Provide "spacers" of specific widths to allow the consoles to be installed from corner-to-corner with no gaps. Provide positions for local control, ground control, flight data, and airfield light controls. Provide supervisor overwatch position.

In the Cab, ATC equipment is installed from the front of the consoles so there is no need to have access to the rear of the cabinets. Upgrading or

replacing equipment is done from the front of the cabinets. Cabling comes from below the floor into the bottom of the cabinets.

Cab consoles must not obstruct the controller's visibility and must contain all necessary equipment. Consoles must be constructed as modules sized to permit removal from the Cab. Cab console colors, equipment location and surface configuration design will be coordinated with local ATCT staff.

The contractor must provide and install the airfield lighting panel, power outage indicator lights, door ajar indicator light, dimmer switch for overhead lights, and the master control for the intercom system in the Cab console. Place single "strip bays" at the Local Control Flight Data and Ground Control positions, in addition to the dual "strip bay" provided for the Flight Data position. All other equipment will be provided and installed by the Government. Government installers will accomplish console cut-outs for Government-installed equipment.

- **Army:** Cab consoles are CFCI.
- **Air Force:** Coordinate and validate the Cab console design through E&I, AFFSA, MAJCOM, and the station Air Operations Department to ensure the design accommodates the required equipment.

The location of the Supervisor of Flying (SOF), where required, will be coordinated with the Operations Group (OG) Commander, or designated representative. Provide a sketch of the Cab layout to the ATC staff during design in order to finalize the operational requirements, positions, and equipment layouts.

4-1.2.21 Restrooms.

Provide a minimum of two unisex restrooms. Additional restrooms may be required, depending on functions located in the ATCT shaft. Provide one shower and locker area in towers with more than one restroom where the program requirements reflect a 24-hour work shift.

Restroom doors must be provided with a bathroom door lockset. Restrooms must have one water closet and one lavatory with mirror. Plumbing fixtures should be wall hung to facilitate cleaning and maintenance. Fully or partially recessed (depending on wall depth) towel dispensers with integral waste receptacles should be used. Dispenser/receptacle should have standard stainless steel architectural finish with a removable stainless steel waste container in the bottom receptacle portion. No sanitary napkin dispenser must be installed in unisex restrooms. A sign depicting "In Use" should be included and installed to aid in occupancy notification.

4-1.2.22 Building Signage.

Signage stating "Cell phone use not permitted" is required at the entrance to the Control Cab, IFR Equipment Room and Flight Planning Room. Signage style must match that used throughout the remainder of the facility.

4-1.3 Structural Requirements.

4-1.3.1 Basic Requirements.

It is desirable to provide flexibility for future modifications to occupancy and usage. The minimum floor live load specified below was selected to facilitate future modifications. The Control Cab perimeter walkway live load is required to allow for potential loads related to removal and replacement of window panels.

When a Base Building is required adjacent to the ATCT, design the two to be structurally independent when feasible. This approach is recommended to reduce structural complexity and to facilitate future modification to either structure.

Depending on geometry and stiffness, ATCT structures can be more sensitive to wind and seismic loads than typical buildings due to the slender geometry of the shaft and Cab. Follow procedures provided in applicable UFC documents and national standards for wind and seismic load analysis. Ensure the serviceability limits indicated below are met.

4-1.3.2 Design Live Loads.

Unless a larger load is required, design the structure to withstand the following minimum uniform live loads.

Table 4-1 Design Live Loads

Occupancy or Use	Uniform Load Psf (kPa)
All Floor Levels	150 (7.2)
Cab Perimeter Walkway	60 (2.9)

4-1.3.3 Serviceability.

Serviceability of Control Cab windows is particularly important. In addition to serviceability requirements indicated in UFC 3-301-01 for various components of the structure, take special care to ensure serviceability of window panels at the Cab level. Limit the drift ratio (story lateral deflection/story height) to 0.002 due to design wind loading. Coordinate and review window and mullion details to ensure that windows are designed for the required wind loads, seismic loads, and thermal effects. Coordinate with architectural discipline to provide davits (when required) to facilitate window washing.

Discuss drift requirements for seismic loads with the Government during the design phase. A reasonable approach may be to limit drift ratio to 0.002 for a seismic event less than the maximum considered earthquake.

4-1.3.4 Antenna Support.

Railing at the Control Cab roof is required to withstand the forces imposed by the antennas. Unless more stringent criteria are provided on a project basis, design the railing based on the following parameters in addition to model code criteria:

- Antennas spacing of 24 inches (610 mm) on center for the full length of the railing.
- Antenna size: 3 inch (75 mm) diameter x 17 feet (5180 mm) tall
- Antenna weight: 16 pounds (71 N) each.
- Railing is required to withstand forces imposed by the antennas with 1/2-inch (13 mm) of radial ice and with wind speeds as required by UFC 3-301-01.

4-1.3.5 Support of Control Cab Electronic Monitors.

There are three methods to accommodate electronic monitors used by controllers: Desktop monitors, ceiling tracks, and ceiling track support plates.

4-1.3.5.1 Desktop Monitors.

Due to recent improvements in computer technology, large and heavy television-like monitors are being replaced with lighter flat screens. Typical system monitors weigh an estimated 85lbs. These devices can be placed or mounted to the top of the Cab Consoles. Coordinate requirements with the design of the Cab Consoles.

4-1.3.5.2 Ceiling Tracks.

Some electronic monitors require mounting devices incorporated into suspended ceiling systems. Consult with local ATC personnel for preferences for ceiling track systems.

4-1.3.5.3 Ceiling Support Plate.

Some ATC personnel require a ceiling support plate for their electronic monitors. In this case, the ATCT structure must be designed to include secondary framing that runs directly over the controller position cabinetry of the ATCT Cab. This secondary framing beam should be suspended from the Cab roof structure and braced appropriately. The bottom surface of the suspended beam must be 6 inches (150 mm) clear distance above the suspended ceiling tiles. Align the beam with the interior Cab wall where the controller cabinets are installed. The beam will be used to support either a ceiling track or a mounting plate.

Coordinate the design such that no utilities (e.g. sprinkler system piping) are within 3 inches (75 mm) on either side of the beam. This will ensure that there is adequate clearance for the mounting bracket to be installed. See [Figure 4-4](#) for ceiling track support plate detail.

Figure 4-4 Ceiling Support Plate Section Detail

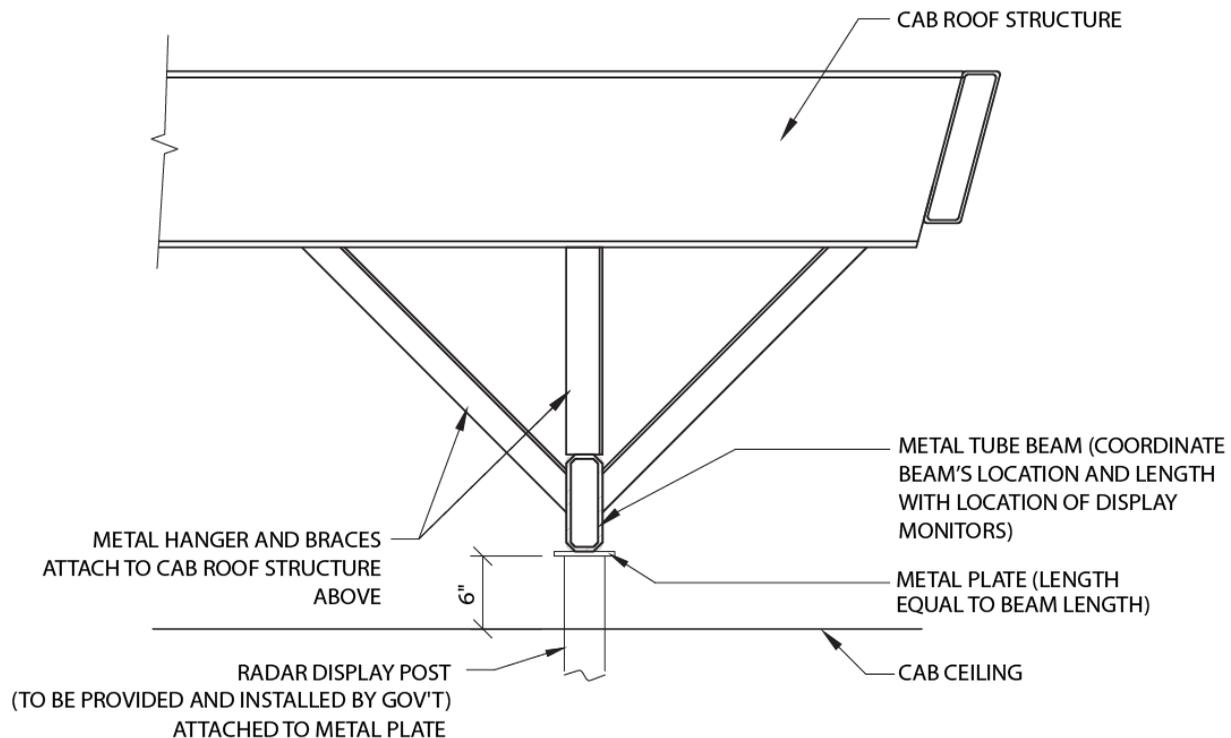

4-1.3.6 Progressive Collapse.

Population density calculation of an ATC tower may not be used to designate a tower with 11 or more personnel as low occupancy. All ATC towers exceeding two stories and routinely occupied by 11 or more personnel must be designed to resist progressive collapse using the UFC 4-023-03 excluding the Tie Force method. Progressive collapse mitigation allows for only safe egress of the facility. Some ATC towers may require continued operation after an event which would require a higher level of protection. Therefore, ATC towers must be evaluated to determine if a higher level of protection is required. Use the process in UFC 4-020-01 to identify the design criteria, which includes the assets to be protected, the DBT, and the levels of protection.

4-1.3.7 Control Cab Roof and Columns.

The Control Cab must use a clear span roof structure so that controllers have 360 degrees of clear view.

Cab columns must be hollow structural shapes. Typically, the columns are sloped in order to provide support of windows with the required downward angle of view. Coordinate column sizes with local ATC personnel to maximize visibility of the airfield. The goal is to minimize the dimensions of the Cab columns in order to minimize obstructed views. Structural shapes should not exceed a width of 6 inches (150mm). Refer to [Figure 2-2](#).

4-1.4 Mechanical Requirements.

4-1.4.1 HVAC Criteria.

The primary HVAC system design objective is to provide environmental control for ATC electronic equipment and personnel. In electronic equipment areas, provisions for temperature and humidity control within the room and under the Raised Access Flooring (RAF) must be installed. Special attention must be given to factors involving installation, maintenance, operation, and reliability with consideration given to diversity and economics. HVAC system design simplicity must be a design goal. HVAC equipment must be limited to serving one or two floors.

- The Control Cab and the supporting electronics equipment areas are considered Critical spaces. Refer to Indoor Design Conditions, General HVAC Requirements, and other information described in Chapter 3-4, *Mechanical*.
- Testing, balancing, adjusting, and commissioning of the HVAC system must take place prior to Government acceptance. This is critical because the heat load varies on each floor because of the different heat output of the equipment.
- Provide an Emergency Air Distribution Shutoff Switch on each floor. Activation of the Shutoff Switch shall shutdown ventilation to the entire building but shall not shut down critical space cooling. Activation of the Emergency Air Distribution Shutoff Switch shall close the outdoor air damper for the Cab Air Handling Unit but the unit shall continue to run on full return air.

4-1.4.2 HVAC Requirements.

Detailed descriptions of required spaces and HVAC system requirements are as follows:

4-1.4.2.1 Control Cab.

The Control Cab is a poorly insulated glass box subject to the maximum effects of changes in atmospheric conditions. Solar gain, greenhouse effect, humidity, conductive heat loss, and convection are forces that influence the design of a specialized Cab HVAC system. Proper air distribution must be controlled to maximize comfort in the Cab. When necessary, ceiling fans must be considered to improve air distribution throughout the space. Supply air must be equally distributed around the perimeter of the Cab and operated continuously at constant volume. Air distribution must be provided along the perimeter of the Cab to prevent glass fogging. Return air must be collected from registers located near the floor or down the stairway and designed to minimize noise transmission from the air handlers. Economizer cycles for the HVAC system must not be utilized, avoiding exposure of critical electronic equipment to wide fluctuations in humidity. The Cab HVAC system must be designed as multiple units in parallel to provide 100 percent cooling redundancy. The Cab HVAC system must serve only the Cab and adjoining spaces within the same fire area. Failure of one unit must allow continuing operation of the second unit. Cabs may be equipped with more than one temperature sensor to allow averaging temperatures throughout the Cab.

4-1.4.2.2 Control Cab HVAC Distribution.

The air distribution system must follow configurations and patterns that are standard to the industry (SMACNA standards). Low and medium pressure ductwork systems must be used where possible. Duct sections with inherently high airflow resistance must be avoided. The number of sharp turns and branching patterns that create airflow turbulence must be minimized. Ductwork must be thermal/noise insulated and must be free of obstruction from auxiliary hardware. Design ductwork to utilize minimum fan horsepower. Exterior insulation must be considered in lieu of duct lining material when required to reduce possible long-term moisture build-up that may lead to growth of mold.

Air distribution must be continuous under the window diffuser system. The duct system must be low noise with a maximum static resistance of 21.17 Pa per 30.5 m (0.085 in of water per 100 linear ft). The duct routing must be under the RAF and coordinated with electrical and equipment wiring routes. Access in the base of the structural columns is critical for installing antenna cables. Diffusers must be floor-grade, linear type, and located at the base of the windows, providing an even coverage of glazing preventing condensation and drafts. Duct system must be coordinated with the structure, electrical, control cabinet sizes, and proximity to the window.

4-1.4.2.3 Sill Area.

The Control Cab window sill area is often used to support the weight of a person cleaning the interior surface of the windows. The design must ensure the air vents located in the Cab window sill and the sills themselves are strong enough to support a 250lb point load for personnel standing on the sills and diffusers.

4-1.4.2.4 Control Cab HVAC System Location.

HVAC systems are located directly below the Control Cab, either on a mezzanine level in the overhead of the floor below the Cab, or on a full floor. Locating HVAC systems on a mezzanine level works well, provided enough space is allocated, including space for maintenance. Provide redundancy for the Cab air handling unit.

- Provide a ducted supply from the air handlers on the floor below the Cab to the diffusers in the Cab sills. HVAC units are not permitted on the Cab roof.
- HVAC ductwork, which may be installed inside the Control Cab wall, must be designed to be as narrow as practical to keep the wall as narrow as possible. HVAC ductwork installed in this wall must not interfere with access to the column cableways or the routing of cables into the cableway.
- It is preferred not to have HVAC systems in overhead spaces because of maintenance difficulty with the limited space available.
- Electrical rooms may require cooling due to the UPS batteries.
- HVAC ducting under the RAF must be routed such that the area along the Cab wall is not used entirely for ducting. Ducts running around the perimeter of the Cab blocks access to the concrete sub floor to secure the position cabinetry. Ducts should exit the Cab wall perpendicular to the wall.

During design, the locations of the duct work and floor penetrations must be reviewed to ensure that they will not interfere with the position consoles.

4-1.4.2.5 Utility and Elevator Shafts.

These spaces usually require natural ventilation only. Storm-proof louvers must be provided to the outside at the top portion of each shaft. Air intake at lower levels may be via passage door, space under doors, or louvers at the base level. Utility chase spaces containing water pipes and drain lines must be heated to maintain a minimum temperature of 40° F.

4-1.4.2.6 Stairwell.

Space conditioning for ATCT Tower Stairwell is not required. However, the stairwell must be controlled to mechanical room standards. Stair sections must be heated above the top elevator landing which leads to the Cab. Heating may be required in some locations due to extreme winter temperatures. Special attention may be required for high humidity areas to prevent condensation in the Stairwell.

4-1.4.2.7 Pipe Chase.

The pipe chase must be fire-stopped at every floor. To prevent freezing, the chase must be opened with louvers, one high and one low between each floor.

4-1.4.2.8 Smoke Dampers.

An elevator shaft smoke damper must be provided to meet life-safety criteria.

4-1.4.2.9 Energy Management and Control System (EMCS).

All new and altered ATCTs must be designed so they can be monitored by an Energy Management and Control System (EMCS). The EMCS must have the capability to monitor lighting systems, security systems, and other systems. Consult the base EMCS office for the design requirements since each base is different.

Due to “Mission Essential” staffing requirements and flight safety considerations, the ATCT occupants, must have direct control of the thermostat to regulate appropriate heating and cooling levels. Configure thermostats so Base EMCS can monitor but not control temperature levels.

Zone the HVAC system so that Control Cab occupants can control the temperature in the Cab. Electronic equipment rooms must be treated as separate zones with their own thermostats. Other floors must be controlled by thermostats zoned to those floors.

4-1.5 Plumbing Requirements.

4-1.5.1 Plumbing Fixtures and Equipment.

Any floor above ATCT Electronic Equipment Rooms must be provided with a floor drain to prevent flooding in case of a water leak. All floor drains must be provided with self-

priming traps or another means to maintain the water level in the traps, which will prevent sewage gasses from entering the ATCT spaces.

- Provide drainage from the elevator pit.
- The ATCT will likely need a water pressure booster system to get water to the Control Cab. Provide a duplex pump system and tanks to provide ample pressure for the domestic water system if the system does not have adequate pressure.
- In the Mechanical Room, provide floor sink for maintenance. Provide floor drains for all mechanical equipment with condensate drains. If ultrasonic humidifiers are used in the Electronic Equipment Rooms or the Cab, provide de-ionized water system to supply the humidifiers.
- In the Fire Pump Room, provide floor sink for system maintenance and back flow preventer drainage.
- In the Janitors Closet, provide floor-mounted mop sink and floor drain.
- Small instant type water heaters are required at each lavatory/sink. A larger instant type heater to serve multiple points of use can be considered if the fixtures are located close together.

4-1.5.2 Catwalk.

Provide freeze-proof hose bib at the exterior door to the Cab catwalk and at the exterior of the ground floor of the ATCT.

Area drains may be provided on the catwalk or the catwalk may be sloped to the exterior for positive drainage.

4-1.5.3 Control Cab Roof.

Provide roof drain and overflow roof drains or scuppers. Minimize exterior downspouts because roof drain pipes interfere with views from the Control Cab. All pipe routings between the roof and the Cab floor, including roof drainage and sprinkler piping, must be routed within or adjacent to the structural columns or mullions at the back of the Cab adjacent to the Cab stairway (away from the primary viewing areas).

In cold weather climates, roof drain hubs and downspout piping must be insulated. The insulation, for the downspout pipe within the Cab roof support column must be 1/2-inch (12-mm) thick foam rubber with the remaining tube void filled with foam insulation. It should be noted that the Cab structure tube configuration produces a significant interior space limitation. Provide electrical heat tapes and insulation for water pipes where required. Heat tapes shall include thermostat control with visual indicator for "ON" condition. Where possible, provide 18 inches (450 mm) heat tape clearance access all around. Heat tape shall not be used on fire protection piping.

4-1.5.4 Convenience Unit.

A convenience unit is required to allow the air traffic controllers on watch in the Control Cab to prepare light meals without leaving their duty station. These units typically contain

a sink with hot (on-demand) and cold water, a drinking fountain, a frost-free refrigerator, and a microwave oven. Coordination with the local ATC personnel is required to determine the specific features desired.

4-1.6 Fire Protection and Life Safety Requirements.

4-1.6.1 Fire Alarm and Detection Systems.

All audible and visual notification devices must be "private mode" devices. Private mode audible devices in the Control Cab will sound for at least 180 seconds (required by NFPA 72 18.4.2.3). Provide a textural private mode device above each exit door for visual text alarm and notification messages.

Audible devices in the Cab must be capable of being manually acknowledged in the Cab, which will interrupt (silence) the audible devices in the Cab before 180 seconds (permitted by NFPA 72 18.4.2.3). Visual devices shall include a blue flashing incandescent light instead of a strobe fixture. Red lights are not allowed.

4-1.6.2 Sprinkler Head Cover Plates.

The cover plates for the sprinkler heads in the Control Cab must be flat black in color.

4-1.6.3 Standpipes.

Class 1 standpipe systems shall be installed in all ATCTs with a Control Cab floor more than 30 feet above the level of Fire Emergency Services (FES) access. Fire hose valves (FHV) shall be located in every stair at each landing serving an occupied or service area level.

4-1.6.4 Smoke Detectors.

Smoke detectors installed in the Control Cab ceiling must be flat black in color.

4-1.6.5 Remote Alarm Panel.

A remote annunciator panel with a local audible alarm is required to be installed in the Control Cab to allow air traffic controllers to monitor alarms. Provisions must be made to allow controllers to silence the local audible alarm generated by the annunciator panel, but not the fire alarm indication.

4-1.7 Electrical Requirements.

4-1.7.1 Critical Power Panels.

4-1.7.1.1 Control Cab.

One Critical power panel is required in the Control Cab, or the uppermost floor directly below the Cab, to provide the Critical power requirements. The preferred location of this power panel is near the stairwell for easy access in case of an emergency.

Note: Flush mounting is the preferred method of installation for the Cab power panels. An access gutter or spare conduits are required between the bottom of the flush-mounted panels and the void below the RAF. This provision will allow installation of branch circuits at a later time.

4-1.7.1.2 Electronic Equipment Spaces.

At least one Critical panel is required in the electronic equipment spaces of the ATCT to provide the power for electronic equipment installed in these spaces. The design of the ATCT will dictate the number of spaces required and therefore the number of Critical panels.

At least one Critical power panel is required in the space housing the Emergency Communications System (ECS) in order to provide the power for Voice Communications Switching System (VCSS) electronic equipment.

Note: Surface mounting is the preferred method of installation for the power panels in the electronic equipment spaces. The location of these panels must provide sufficient safety clearances for maintenance personnel per the NEC. Do not mount power panels directly below the cable tray penetration in ATCT Electronic Equipment Rooms.

4-1.7.2 Critical Power Circuits.

4-1.7.2.1 Control Cab.

Critical power circuits are required below the RAF in the Control Cab. Two Critical power circuits, with dedicated neutral conductors, are required to each controller position and must terminate in a 4-inch (100-mm) x 4-inch (100-mm) junction box under each controller position in the Cab. Provide a 24-inch (610-mm) service loop at each junction box. The quantity of circuits, the number of junction boxes, and the exact location of the junction boxes will be determined during design.

4-1.7.2.2 Control Cab Ceiling.

The Control Cab ceiling requires one or two pairs of ceiling junction boxes, each pair connected to a corresponding pair below the RAF. Each junction box must be 4-inch (100-mm) x 4-inch (100-mm) x 1-1/2-inch (38-mm). These junction boxes must be connected with flexible metal conduit, with one 3/4-inch (20-mm) conduit and one 1-1/4-inch (30-mm) for each pair. The conduit routing must be inside the window mullion. The exact quantity and location of the junction boxes will be identified during design.

Note: Additional wired outlets may be required in the ceiling area for relocated signal light guns. Consult with local ATC personnel for specific requirements.

4-1.7.2.3 Roof.

The ATCT roof will require Critical power service. This service must provide power to obstruction lights installed as part of construction. Any additional critical power required on the roof should be identified during design.

4-1.7.3 Non-Critical Power Circuits.

The ATCT roof requires non-critical power service, consisting of two weatherproof duplex 20A outlet boxes, which must be placed on opposite sides of the roof. These are required for electronic maintenance use. This service must be Ground Fault Interrupt (GFI) protected.

The ATCT catwalk requires non-critical power service, including one weatherproof duplex 20A outlet box, which must be placed adjacent to the access door. This outlet is required for maintenance use.

Non-critical outlets must not be designed into the Control Cab wall areas where ATC equipment consoles will be located.

4-1.7.4 Emergency Electrical Power.

4-1.7.4.1 UPS.

Provide a UPS system for critical power near the Control Cab and all ATC electronic equipment areas. Use the anticipated load to determine the size of the UPS. For UPS units serving ATCTs, minimum size must not be less than 20KVA. ATC electronic equipment loads should be provided during the planning/DD 1391 development process.

4-1.7.4.2 Remote Monitoring of Emergency Generator.

Remote monitoring of the ATCT generator must be provided. Personnel in the ATCT Control Cab may be unaware if the generator is running. Locate the monitor in the ATCT Cab.

4-1.7.4.3 Emergency Lighting.

Emergency lighting must be provided in the Control Cab. Provide additional emergency fixtures (conventional with battery-backup or inverter/rectifier located in the fixture ballast) in the Stairwell and ATC equipment rooms.

4-1.7.4.4 Emergency Power-Off Switch.

The electronic equipment space(s) in the ATCT require one Emergency Power-Off (EPO) switch in each room. A typical location for the Control Cab EPO switch is immediately adjacent to the top of the Cab stairway. The exact location of the EPO switches will be determined during design.

4-1.7.5 Lighting.

All fluorescent lighting fixtures require Radio Frequency Interference (RFI) suppression-type ballasts. All lighting controls in the facility, when more than one exists, should be labeled with which lights they control.

4-1.7.5.1 Control Cab.

Lighting in the Control Cab is divided into two groups: focused and non-focused. The first group is focused and is required to illuminate the controller positions. The second group is non-focused and is designed for general housekeeping usage. Each group requires independent controls and must be capable of variable intensity. The local ATC personnel must determine the location for all wall-mounted ceiling light variable intensity controls. All dimmer switches for controlling the lights in the Cab and Cab Stairwell must be located in the Cab.

Lighting should be compatible with night vision goggle requirements.

All lighting trim rings on ceiling lights shall be flat black.

- Focused Lighting

The focused lighting group is required to illuminate the controller positions. The design must plan for pairs of focused white lights, with each pair illuminating one ATC controller position with its own intensity control. Focused lighting controls (dimmer switches) must be within easy reach of the person sitting in the controller position. Each pair must be recessed into the ceiling to prevent reflections on the window glass and positioned to cancel shadows at the controller console.

After testing, the lighting intensity controls must be coiled and stored under the Raised Access Flooring (RAF) with sufficient cable length to permit mounting the controls on each controller console, which will be installed after construction is completed.

Spotlights must be recessed pinhole lights with non-reflective grooved baffles, dimmer controlled, with approximately 2.5 inch (64 mm) opening and a 100-watt bulb.

- Non-Focused Lighting

Separate, non-focused lighting is required for general use. Recessed white ceiling lights are required for general housekeeping purposes. A single, wall-mounted, variable intensity control is required. This light control must have a protective cover to prevent accidental activation of these lights during night operations.

Additional non-focused lighting is required to properly illuminate the stairs leading to the Cab. The stairwell lighting must include variable intensity, white floor illumination (theater-style) lights as well as general purpose lighting. Ensure light fixtures do not create a hazard to personnel or restrict movement of equipment on the stairs.

Overhead lighting must not be used above controller positions. Consider the use of desk-mounted gooseneck lamps to illuminate each position. The gooseneck lamp must be fully dimmable and controlled from each position.

4-1.7.5.2 Electronic Equipment Room(s) and Other Spaces.

Lighting in ATCT Electronic Equipment Room(s) must be consistent with that required in electronic maintenance and administrative spaces. Fluorescent-type lighting is acceptable and there is no requirement for variable intensity control. Light fixtures in the ATCT Equipment Rooms must not be located directly above proposed cabinet installations. To prevent interference with overhead-mounted cable tray, lights must be mounted at least 110 inches (9'-2" or 2790 mm) above the finished floor. Proposed cable tray and cabinet locations will be determined during design. See [Figure 4-1](#) for minimum clearance height details.

Consult with the local ATC personnel for any specific requirements in administrative spaces.

4-1.7.5.3 Roof Obstruction Lights.

Per FAA Advisory Circular AC 70/7460, provide obstruction lighting on the ATCT during and after construction. Although some antennas have lights, the ATCT must have obstruction lighting as part of the structure. Lights that are part of the antennas may be removed at a later date if the communication requirements or communication system design changes.

4-1.7.5.4 Signal Light Guns.

Electrical design must include light gun mounting and power. Local ATC personnel must be consulted to determine if new light guns are required as part of the construction project.

Light gun outlet locations must be determined during design. Eye bolts for hanging the light guns must be installed by the Contractor.

4-1.7.5.5 Exterior Lighting.

Building entrances should be lit to 21.5 lx (2 foot-candles) by High Pressure Sodium (HPS) units. Specify the use of solar powered luminaries when they meet lighting requirements and are cost-effective.

4-1.7.6 Lightning Protection.

Air terminals on an ATCT roof must provide a zone of protection for all antennas to be installed by the Government except for those antennas with built-in lightning protection. These antennas have integral air terminals that must be connected to the lightning protection down conductors during installation. The down conductors on the ATCT roof must be accessible for the later connection of the ECS antennas.

4-1.7.7 Airfield Lighting Control Panel.

Provide an Airfield Lighting Control Panel (ALCP), with connections and interface to the airfield lighting vault. Request review with the local ATC staff to determine if the ALCP is

required. If required, connectivity to the vault or other lighting sites would be installed by the construction contractor.

- **Army:** Where available, integrate ALCP with the Army Airfield Automation System.
- **Navy:** An ALCP is not required, but a connection to the airfield lighting vault may be required. Refer to FRS for specific connectivity requirements.
- **Air Force:** If required, include installation of the conduit and wiring for the ALCP. The size and number of conduit and conductors must be determined on a case-by-case basis. Provide and install the ALCP in the ATCT Control Cab console. -The Contractor should make the physical connection (including underground ducting) from the airfield lighting vault to the ALCP. Provide one 4-inch (10-cm) empty square duct between power panel and the space below the RAF in the ATCT Cab. The ALCP must conform to minimum requirements of FAA Advisory Circular AC 150/5345-3, *Specification of L 821 Panels for Remote Control of Airport Lighting*. Updated, improved controls are encouraged but must be approved by the MAJCOM.

ALCPs in the Control Cab should be designed and programmed for ATC use. Specifically, Sequenced Flashing Lights must be programmed to work in concert with the settings of the Approach Lighting System. (For example, when ALS settings are adjusted, the SFL settings must be coupled to the ALS settings which means they must act as one system without requiring independent setting adjustments by ATC personnel.)

4-1.8 Telecommunications Requirements.

4-1.8.1 Main Distribution Frame (MDF)

An ATCT Main Distribution Frame (MDF) is not required if the ATCT is attached to the RACF.

If the ATCT is not attached to the RACF, provide an MDF in the Telecommunications Room on the ground floor of the ATCT for terminating all outside communications conductors. At this location, all outside plant communications and control conductors must terminate, be protected, cross connected, and distributed throughout the rest of the ATCT. This includes all cables between the RACF and ATCT if the buildings are not connected.

4-1.8.2 ATC Circuit Intermediate Distribution Frame (IDF).

An ATC Circuit Intermediate Distribution Frame (IDF) is where circuits are separated and routed to the ATC equipment. This IDF contains both copper and fiber cables. If required, the ATC Circuit IDF may be located in the ATCT Electronic Equipment Room or the Control Cab. The ATC IDF located in the ATCT must be located on 3/4-inch (20-mm) thick fire-rated plywood, at least 4 feet wide, from floor to ceiling.

4-1.8.3 Internal Facility Connectivity.

Two (2) 4-inch (100-mm) conduits are required between the ATCT MDF and ATCT cable chase exclusively for ATC circuit cabling. Conduits must terminate in the bottom of the ATCT MDF and the bottom of the ATCT cable chase. Bushings must be installed at each end. Nylon pull-cords are required in each conduit.

Any additional connectivity requirements should be addressed during the planning/DD 1391 development phase.

4-1.8.4 Primary Crash Alarm System.

One of the phone lines in the Control Cab will be uniquely identified as the "Crash Phone" line. This circuit will be terminated in a junction box under the raised access floor. The junction box shall have one CAT 6 telephone jack. The exact location of this circuit will be identified during design.

4-1.9 Safety and Security.

ATCTs are normally located within restricted areas that meet the minimum security measures for external security. If the facility is located within a restricted area of a lower level of security, provide additional measures to meet the minimum security requirements for the level of security assigned to the facility.

When the ATCT is outside the Security Zone perimeter, a 10-foot-high fence with single razor wire will completely enclose the tower structure. The fence must be not less than 15 feet from the structure exterior and include a lockable personnel gate not less than 40 inches (1015 mm) wide, and a vehicle lockable access gate not less than 15 feet wide.

4-1.9.1 Doors and Cipher Locks.

The exterior entry doors must be equipped with non-removable hinges and locking hardware including cipher locks. Doors equipped with electronic cipher locks are required to be powered from a critical power circuit (Uninterruptible Power Supply [UPS]).

Provide and install cipher locks, door closers, and electric strikes on the ground floor main entrance door to the ATCT and the door entering the stairs going to the Control Cab. The lock on the main entry and cab doors must have a remote control override switch, controlled from the Cab.

Provide a light in the Cab console which indicates when either of these doors is not closed. Any indicator lights for doors not closed should be wall mounted on the stair wall or other location.

To allow selective access to personnel who do not have the combination, ATCT doors with cipher locks must be releasable from inside the ATCT Cab via a door release switch. This switch must be provided with an electric strike for remote release from the Cab. Doors equipped with electronic cipher locks are required to be powered from a Critical power circuit (UPS).

The small door from the Cab to the catwalk should not be automatically lockable. A manually activated deadbolt engaged from the inside is acceptable. If an outside ladder or stair is provided from the catwalk to the pressurized stairwell, the door leading into the stairwell must not be capable of locking. This door serves as the secondary egress from the Cab.

ATCT electronic equipment spaces require doors with locking hardware. The locking hardware must comply with the requirements of NFPA 101. Standard commercial-grade key locks will suffice for the equipment spaces.

If the ATCT elevator design utilizes an elevator with a door that opens directly into the electronic equipment space(s), a means to "lock out" the elevator from stopping at these space(s) is required. This lockout capability must be activated from inside the elevator cab.

4-1.9.2 Access Control System.

Provide an intercom station and a video camera system to monitor the ATCT doors equipped with cipher locks such as the ATCT ground floor entrance and the final stairs leading to the Control Cab. This system allows the controllers in the Cab to identify, communicate if needed, and grant access to individuals not having pre-approved access. If the intercom station is located on the exterior of the ATCT, it must be installed in a weatherproof box. Consider including a canopy in the design if the main entry is not under the roof.

Typically, the video camera monitors are located in the Cab. The video from these cameras does not go anywhere but to the controllers' point of use.

The video cameras and monitors must be provided as part of MILCON construction. These cameras are used for access control only, and should not be classified as "security" cameras. Without these cameras, someone needing access could potentially wait for an extended length of time before gaining access, because the controllers can't always leave their position to open a door.

4-1.9.3 Airfield Monitoring Cameras.

Provide a video camera system for the monitoring of obstructed airfield areas, if necessary, for 100% visibility of all airfield traffic surfaces. Cameras cannot be used to view any runway surface, only taxiways, parking areas, loading areas, etc. Cameras are also used to monitor weapons loading areas if they are obstructed from view. Additional cameras are added as needed for each area that is obstructed. The obstructed areas must be identified during the Site Selection process.

4-1.9.4 Voice Communications.

Doors with cipher locks in the ATCT require two-way communications between personnel in the Control Cab and personnel not having the combination but needing access. Consult with the local Air Operations Department for specific requirements.

Provide and install an intercom station at the main entrance to the ATCT and at the entrance to the Cab. The intercom station located on the exterior of the ATCT must be installed in a weatherproof box.

An intercom system must be provided and installed to allow audible communication between all floors and stations. The intercom system must be simple and allow the Cab to do an "All-Call" to every floor, including the Simulator Classroom (if provided). Master control must be located in the Cab. The intercom system is purchased and installed by the Contractor.

Connect exterior intercom system to the base telephone system in case of emergency.

4-2 RADAR APPROACH CONTROL FACILITY (RACF).

4-2.1 General Requirements.

4-2.1.1 Risk Category.

For Risk Category, see Table 2-2, UFC 3-301-01. This classification has an impact on the design of most design disciplines involved with a RACF, including architecture and structural, mechanical, electrical and fire protection engineering. Ensure that non-structural components (e.g. raised access flooring, architectural components, utilities, etc.) are laterally braced as required for seismic load stability in accordance with UFC and building code provisions. Careful analysis of these requirements must be addressed in the planning/DD 1391 development phase. Coordinate additional bracing requirements to avoid interference with items to be installed post construction, such as cabling, conduit raceways and other infrastructure for electronic equipment.

4-2.2 Architectural Requirements.

4-2.2.1 Raised Access Flooring.

Provide Raised Access Flooring (RAF) in the Operations/IFR Room, the IFR Equipment Room, and the STARS and ATCT Simulator Room with 18 inches (450 mm) of clearance provided between the floor panels and sub floor to accommodate wiring and insulated piping.

4-2.2.2 Floor Finishes.

The Operations/IFR Room and Simulator Rooms must be provided with integral, static-dissipative carpet. The IFR Equipment Room must be provided with vinyl or laminate floor tiles or carpet with integral static dissipative coverings. Consult with local ATC personnel for preferred floor finishes.

4-2.2.3 Interior Walls.

Sound attenuating wall panels for the Operations/IFR Room are required to absorb noise generated from within the room.

All interior exposed surface treatments in the Operations/IFR Room must be non-glare and non-reflective.

4-2.2.4 Ceiling Finishes.

A black or white ceiling is required in the Operations/IFR room and the Simulator Rooms. Black tiles should be the same as the ceiling in the ATCT Control Cab. Consult with local ATC personnel for preferred ceiling color.

4-2.2.5 Ceiling Heights.

The minimum clear height in the RACF from the finished floor to the bottom of a finished ceiling must be 9'-0", except for the following conditions:

- The RACF Operations/IFR Room and the IFR Equipment Room must have a clear ceiling height of 10'-0" above the RAF.

Final floor-to-floor heights will be determined during design.

4-2.2.6 Acoustical Treatment.

Provide full height 3-1/2" (90-mm) thick sound attenuation batt. insulation in all walls surrounding the Operations/IFR Room:

- Partitions must be constructed to provide a minimum STC rating of 45. Consider increasing this requirement if the RACF is located adjacent to a runway.
- Operations/IFR Room doors must be solid core and rated STC 35 or higher.
- As a minimum, doors should have acoustical seals around all frames.
- An acoustical sill may be provided between Operations/IFR Room and external rooms. Do not provide a sill between the Operations/IFR Room and the IFR Equipment Room since it may obstruct movement of equipment.

4-2.2.7 Roof Access.

A personnel access hatch and ladder/stairs is required to transit from inside the RACF to the roof to maintain antennas mounted on the roof. Any requirement for roof walking pads must be identified during the planning/DD 1391 development phase.

4-2.2.8 Antenna Mounting.

An area for miscellaneous antenna mounting on the RACF roof may be required. If required, the system must consist of a 10 to 20 foot long railing with weather head(s) and conduit to an inside cable path, and must include lightning protection and grounding per FAA standards.

Any requirements for this antenna mounting area must be identified during the planning/DD 1391 development phase.

4-2.2.9 Roof Cable Access for GPS Antenna Infrastructure.

A cable path is required from the space below the RAF in the IFR Equipment Room to the roof of the RACF. One 2-inch (50-mm) rigid conduit is required. This conduit will be used to route antenna cabling to the roof.

- An enclosure with a back panel, mounted to the conduit, is required. The enclosure must be a 16-inch (400-mm) wide by 12-inch (300-mm) high by 8-inch (200-mm) deep, stainless steel, Hoffman-style enclosure.
- All conduits must utilize sweep bends.
- Anti-chafing bushings are required at both ends.
- The interior end of the conduit must be connected to the IFR Equipment Room cable tray or terminate within 6 inches (150 mm) of the cable tray.
- The conduit must protrude 18 inches (450 mm) above the roof and be bonded to the lightning protection system. The location of this conduit must be on the portion of the RACF roof that has a southern exposure. The exact location must be determined during design.

4-2.2.10 Doors.

- Double door access is required between the Operations/IFR Room and the IFR Equipment Room. In addition, double door access is required between the IFR Equipment Room and the outside loading area. At least one leaf of double-door sets must be 48 inches (1220 mm) wide, if the center support is not removable. Doors from the IFR Equipment Room to the Maintenance Room and from the Operations/IFR Room (if directly connected) to the Maintenance Room must be a minimum of 48 inches (1220 mm) to allow passage of equipment being maintained.
- All other doors in equipment areas must be a minimum of 42 inches (1050 mm) wide. All other doors (office, toilet, etc.) must be a minimum of 36 inches (910 mm) wide.
- The primary building entry door should be steel with a wire-glass vision lite and cipher lock. All exterior doors must be steel.
- Provide a small, narrow wire-glass lite in the Operations/IFR Room door.

4-2.2.11 Vertical Cable Chase.

If connectivity with the ATCT utilizes an overhead cable tray, a short vertical cable chase may be required in the IFR Equipment Room. Specific requirements will be identified during design.

4-2.2.12 Cable Tray System.

Connectivity of the cable tray between the Operations/IFR Room, the IFR Equipment Room, and the ATC/STARS Simulator Rooms is required. If bulkheads or walls are installed below the RAF between these rooms, two (2) penetrations will be required to connect the cable tray between the Operations/IFR Room and the IFR Equipment Room.

One (1) penetration is required for all other rooms. If required, cable tray penetrations connecting adjacent rooms must be located below the door access between those rooms. All cable tray penetrations between spaces must comply with applicable fire protection codes.

- A 12-inch (300-mm) or 18-inch (450-mm) wide by 4-inch (100-mm) high (fill depth) ladder-type cable tray is required below the RAF in the Operations/IFR Room. The exact size and location of this cable tray will be determined during design.
- A 12-inch (300-mm) or 18-inch (450-mm) wide by 4-inch (100-mm) high (fill depth) ladder-type cable tray is required below the RAF in the IFR Equipment Room. The exact size and location of this cable tray will be determined during design. Connectivity of this tray to the ATCT vertical cable chase is required utilizing either conduit or cable tray.
- A 12-inch (300-mm) wide by 4-inch (100-mm) high (fill depth) ladder-type cable tray is required below the RAF in the ATC Simulator and STARS Simulator Rooms. The exact location of this cable tray will be determined during design.

See Section 3-8.10 for connectivity requirements between the ATC MDF Enclosure and the IFR Equipment Room.

4-2.2.13 Building Signage.

Signage stating “Cell phone use not permitted” is required at certain ATC Facility operational spaces such as the entrance to the IFR Equipment Room, and the IFR Room. Signage style must match that used throughout the remainder of the facility.

4-2.2.14 Building Loading Area.

Provide an exterior building loading area adjacent to the double doors to the IFR Equipment Room. The driveway leading to this loading area must be at least 15 feet (4570 mm) wide.

4-2.3 Structural Requirements.

4-2.3.1 Design Live Loads.

Unless a larger load is required, design the structure to withstand the following minimum uniform live loads:

Table 4-2 Design Live Loads

Occupancy or Use	Uniform Load Psf (kPa)
RACF Operations/IFR Room	150 (4.8)
Loading Docks	200 (9.6)

Locker Rooms	50 (2.4)
--------------	----------

4-2.4 Mechanical Requirements.

4-2.4.1 General HVAC Requirements.

Detailed descriptions of required spaces and HVAC system requirements are as follows:

4-2.4.2 RACF Operations/IFR Room.

RAF grilles must be sized and located to provide proper air distribution. Where RAF is not utilized or where two separate equipment and people conditioning systems are used, dampers in an overhead system must control proper air distribution. Either system designed for use in the RACF must provide a comfortable working environment. Economizer cycles for the HVAC system must not be utilized, avoiding exposure of critical electronic equipment to wide fluctuations in humidity. Under-floor pressure and air volumetric delivery, measured in cubic feet per minute (cfm) or liters per second (lps), must initially be balanced for the design load. The system must be re-balanced to take advantage of additional design capacity when future equipment is added. Where required by local environmental conditions, the outside air must be carbon filtered at the make-up air intakes for the RACF Operations/IFR Room.

4-2.4.3 Energy Management and Control System (EMCS).

The RACF must be connected to the installation's Energy Management and Control System (EMCS). The EMCS must have the capability to monitor lighting systems, security systems, and other systems. Consult the base EMCS office for the design requirements since each base is different.

Due to "Mission Essential" staffing requirements and flight safety considerations, the RACF occupants, not the base EMCS office, must have direct control of the thermostat to regulate appropriate heating and cooling levels for ATC electronic equipment spaces.

4-2.5 Plumbing Requirements.

No special plumbing requirements have been identified for the RACF.

4-2.6 Fire Protection and Life Safety Requirements.

4-2.6.1 Fire Alarm and Detection Systems.

Audible alarms must not be installed in the Operations/IFR Room. Provide a textural private mode device above each exit door for visual text alarm and notification messages. Two white strobes are required behind the controller position cabinets and two red strobes are required in front of the cabinets in the controller area.

Audible and visual notification devices in operational and technical areas must be 'private mode' devices. Audible and visual notification devices in public areas must be 'public mode' devices.

4-2.6.2 Light Blocking Curtain in Operations/IFR Room.

The Operations/IFR Room may include features such as a light blocking curtain installed over the controller position cabinetry. This curtain will extend from the top of the cabinets to the ceiling. The curtain on the ends of the cabinets will extend from the floor to the ceiling. This curtain must be considered when designing the placement of the recessed sprinklers. The specific location of the curtain will be identified during design.

4-2.7 Electrical Requirements.

4-2.7.1 Space Requirements.

Consult the Systems Integration Engineer (SIE) for power support requirements and panel locations. The SIE will provide a comprehensive list of equipment including their electrical requirements and significant watt or BTU output. Similarly, consult the equipment manufacturers for accurate power requirements, including requirements for power or frequency filters.

4-2.7.1.1 Operations/IFR and IFR Equipment Rooms.

Power distribution panels for the Operations/IFR Room and the IFR Equipment Room must be located in the IFR Equipment Room or adjacent Maintenance Room. These spaces must be supplied separately from the rest of the building.

Provide dedicated circuits for each piece of equipment in the Operations/IFR Room and for each rack in the IFR Equipment Room so that removal for maintenance of any piece of equipment has no effect on the balance of the RACF. Circuits in the Operations/IFR Room should be "clean" to eliminate electrical interference from any other equipment.

4-2.7.1.2 Electrical Room.

The Electrical Room must have exterior access as well as access from within the RACF. A pad-mounted transformer must be provided.

4-2.7.1.3 TERPS.

The TERPS office, if provided, has multiple equipment requirements (computers, scanners, plotters, etc.). Consider replacing standard office duplex locations with fourplex outlets. If practical, provide integral surge protection for these outlets.

4-2.7.1.4 Simulator Room.

Typically, the simulator will require a minimum of 10 each, single pole, 120 VAC, 20 amp circuit breakers and 2 each, single pole, 120 VAC, 30 amp circuit breakers from a 120/208VAC, 60 Hz, three-phase source designed to comply with ANSI C84.1. The total connected load will not exceed 100 amps. Design dedicated circuit breakers for the

proposed tower simulator equipment and separate convenience outlets distributed throughout the classroom.

4-2.7.1.5 Other Building Areas.

Power distribution panels for the spaces outside the Operations/IFR Room and the IFR Equipment Room must be in an electrical closet accessible to base Maintenance personnel. All hallways must have at least one duplex outlet for janitorial personnel. Office spaces must have at least one duplex outlet located for the convenience of janitorial personnel in addition to the standard requirements for an office space.

4-2.7.2 Critical Power Panels.

4-2.7.2.1 Operations/IFR Room.

Two 100 amp critical power panels are required in the Operations/IFR Room. Proposed locations of these power panels will be identified during design.

4-2.7.2.2 IFR Equipment Room.

Two 100 amp critical power panels are required in the IFR Equipment Room. Proposed locations of these power panels will be identified during design.

4-2.7.2.3 ATC Simulator Room.

In lieu of a separate ATC Simulator/Training Room critical power panel, critical power circuits for this room will be provided by the panels located in the Operations/IFR Room.

4-2.7.3 Critical Power Circuits.

4-2.7.3.1 Operations/IFR Room.

Critical power circuits are required below the Raised Access Flooring (RAF) in the Operations/IFR Room. The critical circuits must terminate in a 6-inch (150-mm) by 6-inch (150-mm) by 4-inch (100-mm) deep junction box under the RAF directly below each controller position in the Operations/IFR Room. Each box must contain between one and four circuits. Provide a 24-inch (600-mm) service loop at each junction box.

4-2.7.3.2 IFR Equipment Room.

Critical power circuits are required below the RAF in the IFR Equipment Room. The critical circuits must terminate in a 6-inch (150-mm) by 6-inch (150-mm) by 4-inch (100-mm) deep junction box under the RAF directly below each electronic cabinet or rack in the IFR Equipment Room. Provide a 24-inch (600-mm) service loop at each junction box.

4-2.7.3.3 ATC Simulator/Training Room.

Critical power circuits are required either below the RAF or on the wall in the ATC Simulator/Training Room. The critical circuits must terminate in a standard duplex outlet under the RAF directly below each trainer position or on the wall. In lieu of a separate ATC Simulator/Training Room critical power panel, these junction boxes can be fed from the Operations/IFR Room critical power panel.

The quantity of circuits, the number of outlets, and the exact location of the outlets must be determined during design.

4-2.7.4 Non-Critical Power Circuits.

There are no specific requirements for the RACF non-critical power circuits.

4-2.7.5 Grounding.

In addition to the RACF grounding requirements in the IFR Equipment Room, Operations/IFR Room, and Simulator Room, a single point ground connected to the Equipotential Grounding Plane is required on the plywood panel for the telephone cable breakout. If the ETVS is on a separate rack, provide a grounding connection for this rack.

4-2.7.6 Transient Voltage Surge Suppressors (TVSS).

The power bus for other rooms must be isolated from technical power and critical-technical loads in the Operations/IFR, IFR Equipment and Simulator Rooms to protect such loads from transient voltage variations. Surge protection must reduce lightning and switching surges to within acceptable quality power limits.

4-2.7.7 Emergency Electrical Power.

4-2.7.7.1 Uninterruptible Power Supply (UPS).

Provide a UPS system for critical power near the IFR Equipment Room and all ATC electronic equipment areas. Use the anticipated load to determine the size of the UPS. ATC electronic equipment loads should be provided during the planning/DD 1391 development process.

4-2.7.7.2 Emergency Lighting.

Emergency lighting must be provided in the Operations/IFR Room (spots and floor lights only). In the Operations/IFR Room, emergency lighting should activate only when there is a power failure.

Exit lighting in the Operations/IFR Room must be screened so the lighting will not reflect or cause glare on operational positions. Use LED non-glare exit lighting design.

4-2.7.7.3 Emergency Power-Off Switch.

The IFR Room and IFR Equipment Room require two EPO switches in each. The exact location of the EPO switches will be determined during design.

4-2.7.7.4 Backup Radio Poles and Communications Antennas.

- **Air Force Only:** Provide a minimum of two poles at 25-50 feet (7.5 m – 15 m) from the building and 50 feet from each other for mounting back-up radio antennas. The type and construction of the poles should be verified with the installation's communications squadron. Provide a dedicated panel for troubleshooting lines.

4-2.7.8 Lighting.

All fluorescent lighting fixtures require Radio Frequency Interference (RFI) suppression-type ballasts. All lighting controls in the facility, when more than one exists, should be labeled with which lights they control. Additional guidance is as follows:

4-2.7.8.1 Operations/IFR Room.

Lighting in the Operations/IFR Room will be divided into four functional uses within each operational area ("horseshoe"): blue or red lights inside the horseshoe, white lights inside the horseshoe, theater wall lights inside the horseshoe, and white lights behind the horseshoe. Wall-mounted lighting controls must be installed with a safety switch cover to prevent accidental activation. Blue or red light controls must be readily distinguishable from white light controls. Consult with the local ATC personnel for preference of either red or blue lights. Location of the lighting fixtures with respect to the light blocking curtain will be identified during design.

- Blue or red operation area lights (white fluorescent lights with blue or red, semi-opaque tube covers that are often the center bank of two lights on a four-tube light fixture) must be variable and separately controlled from all other lights. One

variable intensity control must be located near the room main entrance; a second variable intensity control must be located near the door to the IFR Equipment Room. If multiple operational areas are planned, each horseshoe must have an independent light control.

- White operations area lights, which are often the outer bank of two lights on a four-tube light fixture, must be variable and separately controlled from all other lights. One on/off switch with variable intensity control must be located near the room entrance; a second on/off switch with variable intensity control must be run under the RAF with sufficient cable so that the control can be mounted in the supervisor's console or near the entrance to the IFR Equipment Room. If multiple operational areas are planned, each horseshoe must have independent light control.
- Theater-type wall lighting to illuminate the walking area near the walls is required inside or between the horseshoes. One on/off switch with variable intensity control must be located near the room entrance. A second on/off switch with variable intensity control must be centrally located on the wall where the theater lights are installed.
- The area behind each horseshoe requires variable intensity white fluorescent lighting. These lights can be subdivided into left and right side controls. The double set of on/off switches with variable intensity control must be located at each entrance to the IFR Equipment Room. A second set of on/off switches with variable intensity control must be located near the other room entrance. If multiple operational areas are planned, each horseshoe must have independent light control.
- **Army and Air Force:** The Army and Air Force do not have a requirement for colored lights in the IFR Room. However, lights must be 0-100% dimmable in the Operations/IFR Room and 50% dimmable in immediate adjacent areas.

4-2.7.8.2 IFR Equipment Room.

Lighting in IFR Equipment Room must be consistent with that required in electronic maintenance and administrative spaces. Fluorescent-type lighting is acceptable and there is no requirement for variable intensity control. Light fixtures in the IFR Equipment Room must not be located directly above proposed cabinet installations. Lighting must be placed to ensure that the areas between equipment rows are illuminated. Proposed cabinet locations will be determined during design.

4-2.7.8.3 ATCT and STARS Simulator Rooms.

Lights in the ATCT and STARS Simulator Classrooms must be white and must be capable of variable intensity (fully dimmable).

4-2.7.8.4 Other Spaces.

Consult with the local ATC personnel for any specific requirements in administrative spaces.

4-2.8 Telecommunications Requirements.

4-2.8.1 RACF Main Distribution Frame (MDF).

Provide an MDF within the RACF for terminating all outside communications conductors. At this location, all outside plant communications and control conductors must terminate, be protected, cross-connected, and distributed throughout the rest of the RACF. This includes all cables between the RACF and the ATCT if the buildings are not connected.

If the RACF MDF and the IFR Equipment Room are adjacent to each other, RACF can be installed in both rooms and a cable tray must be used for the connectivity. If the two rooms are not adjacent (separated by other rooms or hallways), 4-inch (100-mm) conduits are used to provide the connectivity.

4-2.8.2 ATC MDF Enclosure.

The ATC MDF Enclosure is located within the RACF MDF and is exclusively where all ATC circuits are terminated before being distributed to the ATC equipment spaces. Trunk cables are utilized for the ATC circuits going to the IFR Equipment Room.

A Hoffman-style enclosure (Type 1, 48 inches (1220 mm) high by 36 inches (910 mm) wide by 11 inches (275 mm) deep), including a back panel, is required for termination of all operational ATC circuit inter-site cabling. This enclosure must be wall-mounted in close proximity to the RACF MDF. The bottom of the enclosure must be 24 inches (600 mm) above the finished floor. The door of the enclosure must incorporate a "T" handle latch. A closure accepting a padlock is required.

4-2.8.3 ATC Circuit Intermediate Distribution Frame (IDF).

The ATC Circuit Intermediate Distribution Frame (IDF) is located in the IFR Equipment Room and is where circuits are separated and routed to the ATC equipment and from the equipment to the ATCT. This MDF contains both copper and fiber cables. The IDF in the IFR Equipment Room is inside a prefabricated enclosure.

4-2.8.4 RACF to ATCT Connectivity.

4-2.8.4.1 Attached ATCT.

Four (4) 4-inch (100-mm) conduits or one (1) 12-inch (300-mm) wide and 4-inch (100-mm) deep (fill depth) cable tray is required from the RACF MDF to the ATCT cable chase exclusively for ATC circuit cabling. Conduits must terminate in the bottom of the RACF MDF and the bottom of the ATCT cable chase. Conduits must stub up 4 inches (100 mm) from the concrete floor. Bushings must be installed at each end. Nylon pull-cords are required in each conduit.

Four (4) 4-inch (100-mm) conduits or one (1) 12-inch (300-mm) wide and 4-inch (100-mm) deep (fill depth) cable tray is required from the ATC MDF to the ATCT cable chase exclusively for ATC circuit cabling. Conduits must terminate in the bottom of the ATC MDF and the bottom of the ATCT cable chase. Conduits must stub up 4 inches (100mm) from the concrete floor. Bushings must be installed at each end. Nylon pull-cords are required in each conduit.

4-2.8.4.2 Detached ATCT.

If the ATCT and the RACF are not attached, connectivity is required between the two.

- Four (4) 4-inch (100-mm) conduits are required from the RACF MDF to the ATCT MDF exclusively for ATC circuit cabling. Conduits must terminate in the bottom of each MDF. Conduits must stub up 4 inches (100 mm) from the concrete floor. Bushings must be installed at each end. Nylon pull-cords are required in each conduit.
- Four (4) 4-inch (100-mm) conduits or one (1) 12-inch (300-mm) wide and 4-inch (100-mm) deep (fill depth) cable tray is required from the ATC MDF to the ATCT cable chase exclusively for ATC circuit cabling. Conduits must terminate in the bottom of the ATC MDF and the bottom of the ATCT cable chase. Conduits must stub up 4 inches (100 mm) from the concrete floor. Bushings must be installed at each end. Nylon pull-cords are required in each conduit.

Any additional connectivity requirements should be addressed during the planning/DD 1391 development phase.

4-2.8.5 Internal Facility Connectivity.

Four (4) 4-inch (100-mm) conduits or one (1) 12-inch (300-mm) wide and 4-inch (100-mm) deep (fill depth) cable tray is required between the RACF MDF and ATC MDF exclusively for ATC circuit cabling. Conduits must terminate in the bottom of the RACF MDF and the bottom of the ATC MDF enclosure. Bushings must be installed at each end. Nylon pull-cords are required in each conduit.

Three (3) 4-inch (100-mm) conduits or one (1) 12-inch (300-mm) wide and 4-inch (100-mm) deep (fill depth) cable tray is required from ATC MDF to the IFR Equipment Room. Conduits must stub up 4 inches (100 mm) from the concrete floor. Bushings must be installed at each end. Nylon pull-cords are required in each conduit. Exact location will be determined during design. This cable tray must be connected to the cable tray in the IFR Equipment Room.

Any additional connectivity requirements should be addressed during the planning/DD 1391 development phase.

4-2.9 Safety and Security.

The RACF is normally located within restricted areas that meet the minimum security measures for external security. If the facility is located within a restricted area of a lower level of security, or is located remote and outside of an established restricted area, provide additional measures to meet the minimum security requirements for the level of security assigned to the facility. Security at the main entrance to the RACF requires a single entry point with visitor control.

Remote locks, video cameras, card readers, and/or keypads may be required as components of the IDS. The level of security and the designer's responsibility for particular security elements will be designated by the User command.

4-2.9.1 Doors and Cipher Locks.

The exterior entry doors must be equipped with non-removable hinges and locking hardware including cipher locks. Doors equipped with electronic cipher locks are required to be powered from a critical power circuit (Uninterruptible Power Supply [UPS]).

Provide and install cipher locks, cameras, intercoms, door closers, and electric strikes on any outside or inside entrance doors to the Operations/IFR Room. This approach allows the controllers in the Operations/IFR Room to identify, communicate if needed, and grant access to individuals not having pre-approved access. Cameras are not required on the doors to the IFR Equipment Room. The exterior door into the IFR Equipment Room is required to have entry hardware. This door must be equipped with a cipher lock or standard locking hardware. The Maintenance division will determine the type of lock.

If exterior doors are provided out of the Operations/IFR Room, these doors must not have access hardware on the outside.

4-2.9.2 Access Control System.

Provide and install intercom stations with video camera system at the main entry door of the RACF and the entrance to the Operations/IFR Room to monitor RACF doors equipped with cipher locks. This system will allow for personnel identification, visitor check-in, and to monitor ingress and egress. Adequate space for the video monitor must be provided in the Watch Supervisor's area and in the entry vestibule.

If the intercom station is located on the exterior of the RACF, it must be installed in a weatherproof box. Consider including a canopy in the design if the main entry is not under the roof.

Additional video monitoring may be required at security fencing and guard post for facilities located outside the secure area of the installation. Consult with the local ATC personnel for specific CCTV requirements.

4-2.9.3 Voice Communications.

Provide communication between the main entry door into the Operations/IFR Room and the supervisor position in the Operations/IFR Room.

4-3 AIR OPERATIONS BUILDING (AOB).

4-3.1 General Requirements.

4-3.1.1 Risk Category.

For Risk Category, see Table 2-2, UFC 3-301-01. This classification has an impact on the design of most design disciplines involved with an AOB, including architecture and structural, mechanical, electrical and fire protection engineering. Ensure that non-structural components (e.g. raised access flooring, architectural components, utilities, etc.) are laterally braced as required for seismic load stability in accordance with UFC and building code provisions. Careful analysis of these requirements must be addressed in the planning/DD 1391 development phase.

4-3.2 Architectural.

4-3.2.1 Ceiling Heights.

The minimum clear height in the AOB from the finished floor to the bottom of a finished ceiling must be 9'-0".

Final floor-to-floor heights will be determined during design.

4-3.2.2 Floor Finishes.

The Operations-Airfield Management/Fight Planning Room must be provided with integral, static-dissipative carpet.

4-3.2.3 Roof Access.

A personnel access hatch and ladder/stairs is required to transit from inside the AOB to the roof to maintain antennas mounted on the roof. Any requirement for roof walking pads must be identified during the planning/DD 1391 development phase.

4-3.2.4 Antenna Mounting.

An area for miscellaneous antenna mounting on the AOB roof may be required. If required, the system must consist of a 10 to 20-foot (3 m – 6 m) long railing with weather head(s) and conduit to an inside cable path, and must include lightning protection and grounding per FAA standards.

Any requirements for this antenna mounting area must be identified during the planning/DD 1391 development phase.

4-3.3 Structural.

4-3.3.1 Structural Isolation.

If located adjacent to the ATCT, the AOB must be structurally isolated from the ATCT to prevent pounding during a seismic event.

4-3.4 Mechanical.

4-3.4.1 Energy Management and Control System (EMCS).

The AOB must be connected to the installation's Energy Management and Control System (EMCS). The EMCS must have the capability to monitor lighting systems, security systems, and other systems. Consult the base EMCS office for the design requirements since each base is different.

Due to "Mission Essential" staffing requirements and flight safety considerations, the AOB occupants, not the base EMCS office, must have direct control of the thermostat to regulate appropriate heating and cooling levels for ATC electronic equipment spaces.

4-3.5 Plumbing.

No unique plumbing requirements have been identified for the AOB.

4-3.6 Fire Protection and Life Safety.

No unique fire protection requirements have been identified for the AOB.

4-3.7 Electrical.

4-3.7.1 Space Requirements.

Consult the Systems Integration Engineer (SIE) for power support requirements and panel locations. The SIE will provide a comprehensive list of equipment including their electrical requirements and significant watt or BTU output. Similarly, consult the equipment manufacturers for accurate power requirements, including requirements for power or frequency filters.

4-3.7.2 Electrical Room.

The Electrical Room must have exterior access as well as access from within the AOB. A pad-mounted transformer must be provided.

4-3.7.3 Power Distribution.

Power distribution panels for the spaces in the AOB must be in an electrical closet accessible to base Maintenance personnel. All hallways must have at least one duplex outlet for janitorial personnel. Office spaces must have at least one duplex outlet located for the convenience of janitorial personnel in addition to the standard requirements for an office space.

4-3.7.4 Critical Power Panels.

4-3.7.4.1 Operations – Airfield Management/Flight Planning Room and Weather Station.

Critical power panels are required in the Operations – Airfield Management/Flight Planning Room and Weather Station. Proposed locations of these power panels will be identified during design.

4-3.7.5 Non-Critical Power Circuits.

There are no specific requirements for the AOB non-critical power circuits.

4-3.7.6 Grounding.

In addition to the grounding requirements in the Operations-Airfield Management/Flight Planning Room and the Weather Station, a single point ground connected to the Equipotential Grounding Plane is required on the plywood panel for the telephone cable breakout. If the ETVS is on a separate rack, provide a grounding connection for this rack.

4-3.7.7 Transient Voltage Surge Suppressors (TVSS).

The power bus for other rooms must be isolated from technical power and critical-technical loads in the Operations – Weather Station to protect such loads from transient voltage variations. Surge protection must reduce lightning and switching surges to within acceptable quality power limits.

4-3.7.8 Emergency Electrical Power.

4-3.7.8.1 Uninterruptible Power Supply (UPS).

Provide a UPS system for critical power near all ATC electronic equipment areas. Use the anticipated load to determine the size of the UPS. ATC electronic equipment loads should be provided during the planning/DD 1391 development process.

4-3.7.9 Lighting.

All fluorescent lighting fixtures require Radio Frequency Interference (RFI) suppression-type ballasts. All lighting controls in the facility, when more than one exists, should be labeled with which lights they control.

Consult with the local ATC personnel for any specific requirements in administrative spaces.

4-3.8 Telecommunications.

4-3.8.1 AOB Main Distribution Frame (MDF).

Provide an MDF within the AOB for terminating all outside communications conductors. At this location, all outside plant communications and control conductors must terminate, be protected, cross-connected, and distributed throughout the rest of the AOB.

4-3.8.2 ATC MDF Enclosure.

The ATC MDF Enclosure is located within the AOB MDF and is exclusively where all ATC circuits are terminated before being distributed to the ATC equipment spaces.

A Hoffman-style enclosure (Type 1, 48 inches (1220 mm) high by 36 inches (910 mm) wide by 11 inches (275 mm) deep), including a back panel, is required for termination of all operational ATC circuit inter-site cabling. This enclosure must be wall-mounted in close proximity to the AOB MDF. The bottom of the enclosure must be 24 inches (600 mm) above the finished floor. The door of the enclosure must incorporate a "T" handle latch. A closure accepting a padlock is required.

4-3.8.3 AOB to RACF Connectivity.

Connectivity between the RACF IFR Equipment Room and the AOB Operations-Airfield Management/Flight Planning Room is required. This and any additional connectivity requirements should be addressed during the planning/DD 1391 development phase.

4-3.9 Safety and Security.

The AOB is normally located within restricted areas that meet the minimum security measures for external security. If the facility is located within a restricted area of a lower level of security, or is located remote and outside of an established restricted area, provide additional measures to meet the minimum security requirements for the level of security assigned to the facility. Security at the main entrance to the AOB requires a single entry point with visitor control.

Remote locks, video cameras, card readers, and/or keypads may be required as components of the IDS. The level of security and the designer's responsibility for particular security elements will be designated by the User command during the planning/DD 1391 development process.

4-3.9.1 Doors and Cipher Locks.

The exterior entry doors must be equipped with non-removable hinges and locking hardware including cipher locks. Doors equipped with electronic cipher locks are required to be powered from a critical power circuit (Uninterruptible Power Supply [UPS]).

4-3.9.2 Access Control System.

Provide and install intercom stations with video camera system at the main entry door of the AOB to monitor AOB doors equipped with cipher locks. This system will allow for personnel identification, visitor check-in, and to monitor ingress and egress. Adequate space for the video monitor must be provided in the Command Suite or Airfield Operations area.

If the intercom station is located on the exterior of the AOB, it must be installed in a weatherproof box. Consider including a canopy in the design if the main entry is not under the roof.

Additional video monitoring may be required at security fencing and guard post for facilities located outside the secure area of the installation. Consult with the local ATC personnel for specific CCTV requirements.

4-3.9.3 Voice Communications.

Provide communication between the main entry door into the AOB and the Command Suite or Airfield Operations area.

This Page Intentionally Left Blank

CHAPTER 5 FUNCTIONAL DATA SHEETS

5-1 INTRODUCTION.

This chapter identifies the specific design needs for the individual spaces within Air Traffic Control (ATC) and Air Operations Facilities. Building design criteria are provided in a standard Functional Data Sheet (FDS) table format that generally follows the Uniformat II / Work Breakdown Structure (WBS). The Interior Construction/Built-In Equipment category includes anything physically attached or plumbed to the building such as counters, cabinets, casework, toilet accessories, window treatments, and retractable overhead screens. The Furnishings and Equipment category includes loose or moveable items.

The Functional Data Sheets are presented as a guide for the designer, planner, or RFP preparer. It is intended that the information in them are the minimum requirements for the respective rooms and spaces. These minimum requirements apply in addition to all other requirements of this UFC and other referenced documents. In the event of a mutually exclusive conflict or where both requirements cannot be satisfied, the Functional Data Sheets take precedence. However, if in the best judgment of the designer, a more restrictive requirement is appropriate, the more restrictive requirement may be applied after consulting with the user.

Not all ATCT's contain all of the areas listed in the following tables. The functional areas required are dependent on operational requirements, and the functions required are determined by the user during the planning/DD 1391 development phase.

Table 5-1.1 ATCT – Main Entrance Lobby/Vestibule

Description / Usage	Main entrance to ATCT	
Ceiling Height	8'-0" minimum	
Windows	Not required	
Doors	Minimum 42" W x 96" H opening – provide vestibule in cold weather areas	
Interior Construction / Built-In Equipment	Building directory and bulletin board	
Finishes	Walls	Plaster or GWB - painted
	Floor	Hard surface (terrazzo, VCT, etc.)
	Base	Terrazzo, rubber or vinyl
	Ceiling	Acoustical ceiling tile or painted GWB
Plumbing		
HVAC	Heating and Cooling (heating only in vestibule)	
Fire Protection and Life Safety	Wet-pipe, automatic fire suppression sprinkler system	
Power	Standard power for office-type areas	
Lighting	As required by UFC 3-530-01	
Communication	Telephone	
	Data	
	CCTV	As required for access control system
	CATV	
	Security	Intercom station and access control system in vestibule – cipher lock, door closer and electric strike on secured door between vestibule (or exterior) and lobby
Acoustics	NC 40	
Furnishings and Equipment		
Special Requirements	A covered or recessed entrance or vestibule is recommended.	
	For use during project execution by the appropriate Service agency	
Occupancy	Staff	
	Other	
Min. net ft² (m²)		

Table 5-1.2 ATCT – Elevator and Elevator Lobby

Description / Usage	Provide one (1) elevator to service all floors of the ATCT from the ground floor to the floor below the floor directly below the Control Cab, or the floor below the Cab if possible. Provide an elevator meeting all IBC requirements on each floor.	
Ceiling Height	8'-0" minimum	
Windows		
Doors	Minimum 42"W x 84"H – single-speed, side-opening, horizontal sliding type	
Interior Construction / Built-In Equipment	Standard elevator cab with stainless steel retractable covers.	
Finishes	Walls	Standard elevator cab with plastic laminate panels
	Floor	Hard surface (terrazzo, VCT, etc.)
	Base	
	Ceiling	Standard elevator ceiling
Plumbing	Floor drain in elevator pit	
HVAC	Ventilate elevator shaft – air enters low and exits high	
Fire Protection and Life Safety	Conform to UFC 3-600-01 and ASME/ANSI A17.1, <i>Safety Code for Elevators and Escalators</i> . Provide smoke detection. For Army and Navy comply additionally with NAVFAC ITG 2013-01 <i>NAVFAC Elevator Design Guide</i> .	
Power		
Lighting	As required by UFC 3-530-01	
Communication	Telephone	Emergency telephone
	Data	
	CCTV	
	CATV	
	Security	
Acoustics		
Furnishings and Equipment		
Special Requirements		
	For use during project execution by the appropriate Service agency	
Occupancy	Staff/Other	
Min. net ft² (m²)		

Table 5-1.3 ATCT – Elevator Machine Room

Description / Usage	Room housing elevator equipment	
Ceiling Height	Exposed structure. Provide 8'-0" minimum clear height	
Windows	Not required.	
Doors	Minimum 36" W x 80" H	
Interior Construction / Built-In Equipment		
Finishes	Walls	CMU, plaster or GWB – painted
	Floor	Sealed concrete
	Base	
	Ceiling	No ceiling required
Plumbing		
HVAC	Heating and cooling for elevator equipment, based on manufacturer's requirements	
Fire Protection and Life Safety	Conform to UFC 3-600-01 and ASME/ANSI A17.1, <i>Safety Code for Elevators and Escalators</i> . Provide smoke detection. For Army and Navy comply additionally with NAVFAC ITG 2013-01 <i>NAVFAC Elevator Design Guide</i> .	
Power	As required for elevator equipment	
Lighting	As required by UFC 3-530-01	
Communication	Telephone	
	Data	
	CCTV	
	CATV	
	Security	Lockable door with standard commercial-grade key lock
Acoustics	NC 50	
Furnishings and Equipment	Elevator equipment, as required	
Special Requirements		
	For use during project execution by the appropriate Service agency	
Occupancy	Staff	
	Other	
Min. net ft² (m²)		

Table 5-1.4 ATCT – Tower Shaft Mechanical Room

Description / Usage	Room housing HVAC equipment for the lower levels of the ATCT.	
Ceiling Height	Exposed structure. Minimum 8'-0" clear height	
Windows	Not required	
Doors	Minimum 36" W x 80" H	
Interior Construction / Built-In Equipment		
Finishes	Walls	CMU, plaster or GWB – painted
	Floor	Sealed concrete
	Base	
	Ceiling	No ceiling required
Plumbing	Floor drain required if located above an ATC Electronic Equipment Room	
HVAC	Heating/cooling based on manufacturer's requirements	
Fire Protection and Life Safety	Wet-pipe, automatic fire suppression sprinkler system	
Power	As required for mechanical equipment	
Lighting	As required by UFC 3-530-01	
Communication	Telephone	
	Data	
	CCTV	
	CATV	
	Security	Lockable door with standard commercial-grade key lock
Acoustics	NC 50	
Furnishings and Equipment	Mechanical HVAC equipment, as required.	
Special Requirements		
	For use during project execution by the appropriate Service agency	
Occupancy	Staff	
	Other	
Min. net ft² (m²)		

Table 5-1.5 ATCT – Tower Shaft Electrical Room

Description / Usage	Room housing electrical equipment for the lower levels of the ATCT.	
Ceiling Height	Exposed structure. Minimum 8'-0" clear height	
Windows	Not required	
Doors	Minimum 36" W x 80" H	
Interior Construction / Built-In Equipment		
Finishes	Walls	CMU, plaster or GWB – painted
	Floor	Sealed concrete
	Base	
	Ceiling	No ceiling required
Plumbing		
HVAC	Heating and cooling as required for electrical equipment	
Fire Protection and Life Safety	Wet-pipe, automatic fire suppression sprinkler system	
Power	As required for electrical equipment	
Lighting	As required by UFC 3-530-01	
Communication	Telephone	
	Data	
	CCTV	
	CATV	
	Security	Lockable door with standard commercial-grade key lock
Acoustics	NC 50	
Furnishings and Equipment	Electrical equipment, as required.	
Special Requirements		
	For use during project execution by the appropriate Service agency	
Occupancy	Staff	
	Other	
Min. net ft² (m²)		

Table 5-1.6 ATCT – Telecommunications Room

Description / Usage	Telephone/Data Communications Frame Room housing the communications distribution plant for the ATCT. Room only required if the ATCT is a standalone facility.	
Ceiling Height	Exposed structure. Minimum 8'-0" clear height	
Windows	Not required	
Doors	Minimum 36" W x 80" H	
Interior Construction / Built-In Equipment		
Finishes	Walls	Painted 3/4-inch fire-rated plywood, floor to ceiling, all walls
	Floor	Sealed concrete
	Base	
	Ceiling	No ceiling required
Plumbing		
HVAC	Heating and cooling as required for telecommunications equipment	
Fire Protection and Life Safety	Wet-pipe, automatic fire suppression sprinkler system. Provide smoke detection.	
Power	Critical and non-critical power as required for telecommunications equipment	
Lighting	As required by UFC 3-530-01	
Communication	Telephone	As required for telecommunications equipment
	Data	As required for telecommunications and networking equipment
	CCTV	
	CATV	
	Security	Lockable door with standard commercial-grade key lock
Acoustics	NC 50	
Furnishings and Equipment	Telecommunications and networking equipment, as required.	
Special Requirements	Multipoint ground system	
	For use during project execution by the appropriate Service agency	
Occupancy	Staff	
	Other	
Min. net ft² (m²)		

Table 5-1.7 ATCT – Fire Pump Room

Description / Usage	Room housing fire pump for the ATCT.	
Ceiling Height	Exposed structure. Minimum 8'-0" clear height	
Windows	Not required	
Doors	Minimum 36" W x 84" H door; coordinate with fire pump equipment.	
Interior Construction / Built-In Equipment	Provide duplex pump system and tanks to provide ample pressure for the domestic water system. If an ATCT is deemed "mission critical," a redundant fire pump must be provided in accordance with UFC 3-600-01.	
Finishes	Walls	CMU, plaster or GWB – painted
	Floor	Sealed concrete
	Base	
	Ceiling	No ceiling required
Plumbing	Provide floor sink and reduced pressure backflow preventer	
HVAC	Heating and ventilation only	
Fire Protection and Life Safety	Wet-pipe, automatic fire suppression sprinkler system	
Power	As required for fire pump(s) and related equipment	
Lighting	As required by UFC 3-530-01	
Communication	Telephone	
	Data	
	CCTV	
	CATV	
	Security	Lockable door with standard commercial-grade key lock
Acoustics	NC 50	
Furnishings and Equipment	Fire pump(s) and related equipment, as required.	
Special Requirements	May be combined with Mechanical Room	
	For use during project execution by the appropriate Service agency	
Occupancy	Staff	
	Other	
Min. net ft² (m²)		

Table 5-1.8 ATCT – ATCT Simulator Room

Description / Usage	Room housing ATCT simulator for controller training.	
Ceiling Height	9'-0" minimum	
Windows	Recommended but not required	
Doors	Minimum 36" W x 80" H	
Interior Construction / Built-In Equipment		
Finishes	Walls	Plaster or GWB – painted
	Floor	Carpet
	Base	Rubber or vinyl
	Ceiling	Acoustical ceiling tile or painted GWB
Plumbing		
HVAC	Heating and cooling	
Fire Protection and Life Safety	Wet-pipe, automatic fire suppression sprinkler system. Provide smoke detection.	
Power	Critical power as required for simulator equipment and standard power for office area	
Lighting	As required by UFC 3-530-01, with dimmable capability	
Communication	Telephone	One outlet per workstation
	Data	Two outlets per workstation (computer and printer)
	CCTV	
	CATV	
	Security	Lockable door with standard commercial-grade key lock
Acoustics	NC 30	
Furnishings and Equipment	Simulator equipment, as required and ESD chairs on casters for controllers.	
Special Requirements	Multipoint ground system	
	For use during project execution by the appropriate Service agency	
Occupancy	Staff	
	Other	
Min. net ft² (m²)		

Table 5-1.9 ATCT – Administration Area

Description / Usage	Open office area containing systems furniture workstations.	
Ceiling Height	8'-0" minimum	
Windows	Not required	
Doors		
Interior Construction / Built-In Equipment		
Finishes	Walls	Plaster or GWB – painted
	Floor	Carpet
	Base	Rubber or vinyl
	Ceiling	Acoustical ceiling tile or painted GWB
Plumbing		
HVAC	Heating and cooling	
Fire Protection and Life Safety	Wet-pipe, automatic fire suppression sprinkler system	
Power	Standard power for office area	
Lighting	As required by UFC 3-530-01	
Communication	Telephone	One outlet per workstation
	Data	Two outlets per workstation (computer and printer)
	CCTV	
	CATV	
	Security	
Acoustics	NC 40	
Furnishings and Equipment	Freestanding systems furniture, as required	
Special Requirements		
	For use during project execution by the appropriate Service agency	
Occupancy	Staff	
	Other	
Min. net ft² (m²)		

Table 5-1.10 ATCT – Chief Controller's Office, Chief AIC Office, Chief GCA Office

Description / Usage	Private office for Chief Controller, Chief AIC and/or Chief GCA.	
Ceiling Height	8'-0" minimum	
Windows	Recommended but not required	
Doors	Minimum 36" W x 80" H	
Interior Construction / Built-In Equipment		
Finishes	Walls	Plaster or GWB – painted
	Floor	Carpet
	Base	Rubber or vinyl
	Ceiling	Acoustical ceiling tile or painted GWB
Plumbing		
HVAC	Heating and cooling	
Fire Protection and Life Safety	Wet-pipe, automatic fire suppression sprinkler system	
Power	Standard power for office area	
Lighting	As required by UFC 3-530-01	
Communication	Telephone	One outlet
	Data	Two outlets (computer and printer)
	CCTV	
	CATV	
	Security	Lockable door with standard commercial-grade key lock
Acoustics	NC 35	
Furnishings and Equipment	Desk, chair, credenza/bookcase, filing cabinets and two (2) visitor chairs	
Special Requirements		
	For use during project execution by the appropriate Service agency	
Occupancy	Staff	
	Other	
Min. net ft² (m²)		

Table 5-1.11 ATCT – Training Room

Description / Usage	Room for mandatory training.	
Ceiling Height	8'-0" minimum	
Windows	Recommended but not required	
Doors	Minimum 36" W x 80" H	
Interior Construction / Built-In Equipment		
Finishes	Walls	Plaster or GWB – painted
	Floor	Carpet
	Base	Rubber or vinyl
	Ceiling	Acoustical ceiling tile or painted GWB
Plumbing		
HVAC	Heating and cooling	
Fire Protection and Life Safety	Wet-pipe, automatic fire suppression sprinkler system	
Power	Standard power for office area	
Lighting	As required by UFC 3-530-01	
Communication	Telephone	One outlet
	Data	Two outlets per workstation (computer and printer)
	CCTV	
	CATV	As required
	Security	Intercom and lockable door with standard commercial-grade key lock
Acoustics	NC 30	
Furnishings and Equipment	Freestanding furniture, as required	
Special Requirements		
	For use during project execution by the appropriate Service agency	
Occupancy	Staff	
	Other	
Min. net ft² (m²)		

Table 5-1.12 ATCT – Toilet Rooms

Description / Usage	Unisex restroom	
Ceiling Height	8'-0" minimum	
Windows		
Doors	Minimum 36" W x 80" H	
Interior Construction / Built-In Equipment	Include recessed towel dispensers with integral waste receptacles. No sanitary napkin dispenser shall be provided.	
Finishes	Walls	Ceramic tile on moisture resistant GWB – full height
	Floor	Ceramic tile
	Base	Ceramic tile
	Ceiling	Acoustical ceiling tile or painted GWB
Plumbing	One (1) water closet and one (1) lavatory with mirror in each restroom. Include a shower and changing area in at least one toilet room.	
HVAC	Exhaust fan only.	
Fire Protection and Life Safety	Wet-pipe, automatic fire suppression sprinkler system	
Power	Standard power at lavatory with GFI outlets	
Lighting	As required by UFC 3-530-01	
Communication	Telephone	
	Data	
	CCTV	
	CATV	
	Security	Lockable door with bathroom lockset
Acoustics	NC 45	
Furnishings and Equipment		
Special Requirements	Locate one restroom at the ground level and one at the level directly below the Control Cab. Provide sign indicating "In Use".	
	For use during project execution by the appropriate Service agency	
Occupancy	Staff	
	Other	
Min. net ft² (m²)		

Table 5-1.13 ATCT – Janitor Closet

Description / Usage	Space for custodial supplies and equipment	
Ceiling Height	Exposed structure. Provide 8-0" minimum clear height.	
Windows		
Doors	Minimum 36" W x 80" H	
Interior Construction / Built-In Equipment	Include mop rack and storage shelving	
Finishes	Walls	48"H ceramic tile wainscot on moisture resistant GWB – painted GWB above
	Floor	Ceramic tile or sealed concrete
	Base	Ceramic tile
	Ceiling	No ceiling required
Plumbing	One (1) custodial-style floor sink and floor drain	
HVAC	Exhaust fan only	
Fire Protection and Life Safety	Wet-pipe, automatic fire suppression sprinkler system	
Power	Standard power with GFI outlets	
Lighting	As required by UFC 3-530-01	
Communication	Telephone	
	Data	
	CCTV	
	CATV	
	Security	Lockable door with standard commercial-grade key lock
Acoustics	NC 50	
Furnishings and Equipment		
Special Requirements	Provide elevator access to the janitor mop sink	
	For use during project execution by the appropriate Service agency	
Occupancy	Staff	
	Other	
Min. net ft² (m²)		

Table 5-1.14 ATCT – Stairwell

Description / Usage	Pressurized fire-rated stairwell providing emergency egress from the floor below the Control Cab to the ground floor. Minimum stair width must be 44".	
Ceiling Height	Exposed structure. Provide minimum clear height as required by code.	
Windows		
Doors	Minimum 36" W x 80" H, fire-rated as required	
Interior Construction / Built-In Equipment		
Finishes	Walls	CMU, plaster or GWB - painted
	Floor	Sealed concrete
	Base	Rubber or vinyl
	Ceiling	No ceiling required
Plumbing		
HVAC	Stairwell must be pressurized. Heating and/or cooling, to be determined during the planning process	
Fire Protection and Life Safety	Fire-rated enclosure as required by code. Sprinklers as required by NFPA 13. Provide	
Power	Standard power at each landing	
Lighting	As required by UFC 3-530-01	
Communication	Telephone	
	Data	
	CCTV	
	CATV	
	Security	Intercom and access control system – cipher lock, door closer and electric strike at upper door providing access to Control Cab
Acoustics	NC 50	
Furnishings and Equipment		
Special Requirements		
	For use during project execution by the appropriate Service agency	
Occupancy	Staff	
	Other	
Min. net ft2 (m2)		

Table 5-1.15 ATCT – Lower Electronic Equipment Room

Description / Usage	Room for ATC Electronic Equipment	
Ceiling Height	Exposed structure. Provide 110 inches (9'-2") minimum clear height below any obstruction.	
Windows		
Doors	Minimum 36" W x 80" H	
Interior Construction / Built-In Equipment	Overhead cable tray system.	
Finishes	Walls	CMU, plaster or GWB – painted
	Floor	Static dissipative carpet or tile
	Base	Rubber or vinyl
	Ceiling	No ceiling required
Plumbing		
HVAC	CRITICAL AREA: Requires redundant heating and cooling	
Fire Protection and Life Safety	Wet-pipe, automatic fire suppression sprinkler system. Provide smoke detection.	
Power	Critical and non-critical power as required for ATC electronic equipment	
Lighting	Standard fixtures with RF shielding and suppression filters	
Communication	Telephone	One outlet
	Data	As required for ATC electronic equipment
	CCTV	
	CATV	
	Security	Lockable door with standard commercial-grade key lock
Acoustics	NC 50	
Furnishings and Equipment	ATC electronic equipment as required. ESD bench and chairs on casters if required.	
Special Requirements	Multipoint ground system. Elevator access is required for this room.	
	For use during project execution by the appropriate Service agency	
Occupancy	Staff	
	Other	
Min. net ft² (m²)		

Table 5-1.16 ATCT – Upper Electronic Equipment Room

Description / Usage	Room for ATC Electronic Equipment. Preferred location for communications equipment, equipment with antennas, and back-up radio systems.	
Ceiling Height	Exposed structure. Provide 110 inches (9'-2") minimum clear height below any obstruction.	
Windows		
Doors	Minimum 36" W x 80" H	
Interior Construction / Built-In Equipment	Overhead cable tray system.	
Finishes	Walls	CMU, plaster or GWB – painted
	Floor	Static dissipative carpet or tile
	Base	Rubber or vinyl
	Ceiling	No ceiling required
Plumbing		
HVAC	CRITICAL AREA: Requires redundant heating and cooling	
Fire Protection and Life Safety	Wet-pipe, automatic fire suppression sprinkler system. Provide smoke detection.	
Power	Critical and non-critical power as required for ATC electronic equipment	
Lighting	Standard fixtures with RF shielding and suppression filters	
Communication	Telephone	One outlet
	Data	As required for ATC electronic equipment
	CCTV	
	CATV	
	Security	Lockable door with standard commercial-grade key lock
Acoustics	NC 50	
Furnishings and Equipment	ATC electronic equipment, as required. ESD bench and chairs on casters if required.	
Special Requirements	Multipoint ground system. Elevator access is required for this room. Locate room as high in the ATCT as possible to reduce RF loss in the antenna cables going to the roof.	
	For use during project execution by the appropriate Service agency	
Occupancy	Staff	
	Other	
Min. net ft² (m²)		

Table 5-1.17 ATCT – UPS Room

Description / Usage	Room housing the UPS system for the ATCT.	
Ceiling Height	Exposed structure. Minimum 8'-0" clear height	
Windows	Not required	
Doors	Minimum 36" W x 80" H	
Interior Construction / Built-In Equipment		
Finishes	Walls	CMU, plaster or GWB – painted
	Floor	Sealed concrete
	Base	
	Ceiling	No ceiling required
Plumbing		
HVAC	CRITICAL AREA: Requires redundant heating and cooling	
Fire Protection and Life Safety	Wet-pipe, automatic fire suppression sprinkler system	
Power	As required for UPS system equipment, include grounding per FAA Standard. Include EPO switch.	
Lighting	As required by UFC 3-530-01	
Communication	Telephone	
	Data	
	CCTV	
	CATV	
	Security	Lockable door with standard commercial-grade key lock
Acoustics	NC 50	
Furnishings and Equipment	UPS system equipment, as required.	
Special Requirements	May be combined with the Upper ATCT Electronic Equipment Room or the Electrical Room.	
	For use during project execution by the appropriate Service agency	
Occupancy	Staff	
	Other	
Min. net ft² (m²)		

Table 5-1.18 ATCT – Ready/Break Room

Description / Usage	Room for mandatory controllers breaks on the level directly below the ATCT Control Cab	
Ceiling Height	8'-0" minimum	
Windows	Optional	
Doors	Minimum 36" W x 80" H	
Interior Construction / Built-In Equipment	Base cabinets with plastic laminate countertop and wall cabinets above. Accommodate a wet sink.	
Finishes	Walls	Plaster or GWB – painted
	Floor	VCT or carpet
	Base	Rubber or vinyl
	Ceiling	Acoustical ceiling tile or painted GWB
Plumbing	Sink (and floor drain, if located above an ATC electronic equipment room)	
HVAC	Heating and cooling	
Fire Protection and Life Safety	Wet-pipe, automatic fire suppression sprinkler system	
Power	Standard power with GFI outlets	
Lighting	As required by UFC 3-530-01	
Communication	Telephone	One outlet
	Data	Yes
	CCTV	
	CATV	Yes
	Security	Intercom
Acoustics	NC 40	
Furnishings and Equipment	Coffee service, refrigerator, microwave, as well as one table with seating.	
Special Requirements		
	For use during project execution by the appropriate Service agency	
Occupancy	Staff	
	Other	
Min. net ft² (m²)		

Table 5-1.19 ATCT – Control Cab Mechanical Room

Description / Usage	Room housing HVAC equipment serving the Control Cab. May be provided as a mezzanine space above the Ready/Break Room.	
Ceiling Height	Exposed structure. Minimum 8'-0" clear height	
Windows	Not required	
Doors	Minimum 36" W x 80" H	
Interior Construction / Built-In Equipment		
Finishes	Walls	CMU, plaster or GWB – painted
	Floor	Sealed concrete
	Base	
	Ceiling	No ceiling required
Plumbing	Floor drain required if located above an Electronic Equipment Room	
HVAC	Heating and ventilation only.	
Fire Protection and Life Safety	Wet-pipe, automatic fire suppression sprinkler system	
Power	As required for mechanical equipment	
Lighting	As required by UFC 3-530-01	
Communication	Telephone	
	Data	
	CCTV	
	CATV	
	Security	Lockable door with standard commercial-grade key lock
Acoustics	NC 50	
Furnishings and Equipment	Mechanical HVAC equipment, as required.	
Special Requirements		
	For use during project execution by the appropriate Service agency	
Occupancy	Staff	
	Other	
Min. net ft² (m²)		

Table 5-1.20 ATCT – Control Cab Electrical/Communications Room

Description / Usage	Room housing equipment for electrical power and telecommunications service to the Control Cab. Locate near the Control Cab level.	
Ceiling Height	Exposed structure. Minimum 8'-0" clear height	
Windows	Not required	
Doors	Minimum 36" W x 80" H	
Interior Construction / Built-In Equipment	UPS system is required	
Finishes	Walls	CMU, plaster or GWB – painted
	Floor	Sealed concrete
	Base	
	Ceiling	No ceiling required
Plumbing		
HVAC	Heating and cooling as required for electrical and telecommunications equipment	
Fire Protection and Life Safety	Wet-pipe, automatic fire suppression sprinkler system	
Power	As required for electrical and telecommunications equipment	
Lighting	As required by UFC 3-530-01	
Communication	Telephone	
	Data	
	CCTV	
	CATV	
	Security	Lockable door with standard commercial-grade key lock
Acoustics	NC 50	
Furnishings and Equipment	Electrical and telecommunications equipment, as required.	
Special Requirements		
	For use during project execution by the appropriate Service agency	
Occupancy	Staff	
	Other	
Min. net ft² (m²)		

Table 5-1.21 ATCT – Control Cab

Description / Usage	Elevated space having an unobstructed line of sight to the entire airfield and areas over which aircraft movements must be controlled. If required, provide a raised platform for the ATCT Supervisor.	
Ceiling Height	10'-0" ceiling height at controller positions	
Windows	360 degree view – minimize structural supports and window mullions to maximize view from Control Cab to airfield	
Doors	Minimum 36" W x 80" H Cab entrance door and minimum 36" x 42" access door to Catwalk.	
Interior Construction / Built-In Equipment	Raised Access Flooring (RAF), fully grounded and bonded – Data cable tray installed below RAF. Accommodate a convenience unit, if required.	
Finishes	Walls	Plaster or GWB – painted flat black – acoustical panels on exposed walls above windows and below windowsill
	Floor	Static dissipative carpet on RAF
	Base	Rubber or vinyl
	Ceiling	Acoustical ceiling tile – flat black tile and suspended grid – flat black trim on all lighting
Plumbing	(Optional) Convenience unit– floor drain at subfloor below RAF	
HVAC	CRITICAL AREA: Requires redundant heating and cooling	
Fire Protection and Life Safety	Wet-pipe, automatic fire suppression sprinkler system – special audible and visual alarm requirements – see Section 4-1.6. Provide smoke detection. Provide flat black sprinkler cover plates and flat black smoke detectors.	
Power	Critical and non-critical power as required for ATC electronic equipment	
Lighting	Focused and non-focused lighting with dimmable capability. Low level "theater" style lighting at treads in Cab stairway.	
Communication	Telephone	3 total. Refer to Sec. 4-1.8.4
	Data	As required
	CCTV	Access control monitors in Cab
	CATV	
	Security	Cipher lock, door closer and electric strike at door to Cab. Intercom and access control video camera at door to Cab
Acoustics	NC 25	
Furnishings and Equipment	Modular consoles for each controller position – provide ESD chairs that have metal frames with conductive casters and chair-covering material for controllers and supervisor – light guns as required	
Special Requirements	Multipoint ground system. Provide a stairway from the Cab level down to the entrance to the ATCT stairwell. Refer to Table 5-1.14 for ATCT stairwell security requirements.	
	For use during project execution by the appropriate Service agency	
Occupancy	Staff	
	Other	
Min. net ft² (m²)		

Table 5-1.22 ATCT – Electronic Equipment Room for VCSS

Description / Usage	Additional Room for ATC Electronic Equipment (if required) for VCSS.	
Ceiling Height	Exposed structure. Provide 110 inches (9'-2") minimum clear height below any obstruction.	
Windows		
Doors	Minimum 36" W x 80" H	
Interior Construction / Built-In Equipment	Overhead cable tray system.	
Finishes	Walls	CMU, plaster or GWB – painted
	Floor	Static dissipating carpet or tile
	Base	Rubber or vinyl
	Ceiling	No ceiling required
Plumbing		
HVAC	CRITICAL AREA: Requires redundant heating and cooling	
Fire Protection and Life Safety	Wet-pipe, automatic fire suppression sprinkler system. Provide smoke detection.	
Power	Critical and non-critical power as required for ATC electronic equipment.	
Lighting	Standard fixtures with RF shielding and suppression filters.	
Communication	Telephone	One outlet
	Data	As required for ATC electronic equipment
	CCTV	
	CATV	
	Security	Lockable door with standard commercial-grade key lock
Acoustics	NC 50	
Furnishings and Equipment	ATC electronic equipment, as required. ESD bench and chairs on casters if required.	
Special Requirements	Multipoint Ground System	
	For use during project execution by the appropriate Service agency	
Occupancy	Staff	
	Other	
Min. net ft² (m²)		

Table 5-1.23 ATCT – Ground Controlled Approach

Description / Usage	Room housing Ground Controlled Approach (GCA) operations.	
Ceiling Height	8'-0" minimum	
Windows	Recommended but not required	
Doors	Minimum 36" W x 80" H	
Interior Construction / Built-In Equipment		
Finishes	Walls	Plaster or GWB – painted
	Floor	Static dissipative carpet
	Base	Rubber or vinyl
	Ceiling	Acoustical ceiling tile or painted GWB
Plumbing		
HVAC	Heating and cooling	
Fire Protection and Life Safety	Wet-pipe, automatic fire suppression sprinkler system	
Power	Standard power for office area	
Lighting	As required by UFC 3-530-01	
Communication	Telephone	One outlet
	Data	Two outlets per workstation (computer and printer)
	CCTV	
	CATV	
	Security	Intercom speaker for monitoring ATCT access, lockable door with cipher lock access.
Acoustics	NC 30	
Furnishings and Equipment	Freestanding furniture, as required	
Special Requirements	Overhead cable tray	
	For use during project execution by the appropriate Service agency	
Occupancy	Staff	
	Other	
Min. net ft² (m²)		

Table 5-1.24 ATCT – Airspace Information Center

Description / Usage	Room housing Airspace Information Center (AIC) operations.	
Ceiling Height	8'-0" minimum	
Windows	Recommended but not required	
Doors	Minimum 36" W x 80" H	
Interior Construction / Built-In Equipment		
Finishes	Walls	Plaster or GWB – painted
	Floor	Static dissipative carpet
	Base	Rubber or vinyl
	Ceiling	Acoustical ceiling tile or painted GWB
Plumbing		
HVAC	Heating and cooling	
Fire Protection and Life Safety	Wet-pipe, automatic fire suppression sprinkler system	
Power	Standard power for office area	
Lighting	As required by UFC 3-530-01	
Communication	Telephone	One outlet
	Data	Two outlets per workstation (computer and printer)
	CCTV	
	CATV	
	Security	Intercom speaker for monitoring ATCT access, lockable door with cipher lock access.
Acoustics	NC 30	
Furnishings and Equipment	Freestanding furniture, as required	
Special Requirements	Raised access floor	
	For use during project execution by the appropriate Service agency	
Occupancy	Staff	
	Other	
Min. net ft² (m²)		

Table 5-1.25 ATCT – ATC Equipment Maintenance Building

Description / Usage	When a standalone ATCT is remote and not attached to an Airfield Operations Building, a separate building with office/work bench space for technicians will be provided for ATC equipment maintenance. Refer to specific Army requirements in the COS Standard Design.	
Ceiling Height	Minimum 9'-0" clear height	
Windows	Not required	
Doors	Minimum 36" W x 80" H and 72" W x 84" H double door for receiving ATC equipment.	
Interior Construction / Built-In Equipment	Snorkel-type localized standalone exhaust system, as required.	
Finishes	Walls	CMU, plaster or GWB – painted
	Floor	Static dissipative VCT or carpet
	Base	
	Ceiling	Acoustical ceiling tile
Plumbing		
HVAC	Heating and ventilation as required	
Fire Protection and Life Safety	Wet pipe, automatic fire suppression sprinkler system	
Power	As required for maintenance equipment, including grounding per FAA Standard. TVSS required on the panel feeding this room.	
Lighting	As required by UFC 3-530-01	
Communication	Telephone	One outlet minimum
	Data	Two outlets (computer and printer) minimum
	CCTV	
	CATV	
	Security	Lockable door with standard commercial-grade key lock
Acoustics		
Furnishings and Equipment	ESD chairs on casters, ESD storage shelving, ESD cabinets, and ESD workbenches, as required.	
Special Requirements	Multipoint ground system.	
	For use during project execution by the appropriate Service agency	
Occupancy	Staff	
	Other	
Min. net ft² (m²)		

Table 5-2.1 RACF – Lobby/Entry Vestibule

Description / Usage	Main entrance to RACF	
Ceiling Height	9'-0" minimum	
Windows	Not required	
Doors	Minimum 42" W x 96" H opening – provide vestibule in cold weather areas	
Interior Construction / Built-In Equipment	Building directory and bulletin board	
Finishes	Walls	Plaster or GWB - painted
	Floor	Hard surface (terrazzo, VCT, etc.)
	Base	Terrazzo, rubber or vinyl
	Ceiling	Acoustical Ceiling Tile or Painted GWB
Plumbing		
HVAC	Heating and Cooling (heating only in vestibule)	
Fire Protection and Life Safety	Wet-pipe, automatic fire suppression sprinkler system	
Power	Standard power for office-type areas	
Lighting	As required by UFC 3-530-01	
Communication	Telephone	Yes
	Data	
	CCTV	Access Control System
	CATV	
	Security	Intercom station and access control system in vestibule – cipher lock, door closer and electric strike on secured door between vestibule (or exterior) and lobby
Acoustics	NC 40	
Furnishings and Equipment		
Special Requirements	A covered or recessed entrance or vestibule is recommended. Provide a one-way reinforced window and a slot for passing of ID cards in the primary building entry door.	
	For use during project execution by the appropriate Service agency	
Occupancy	Staff	
	Other	
Min. net ft² (m²)		

Table 5-2.2 RACF – ATC Administration Area

Description / Usage	Open office area containing systems furniture workstations	
Ceiling Height	9'-0" minimum	
Windows	Not required	
Doors		
Interior Construction / Built-In Equipment		
Finishes	Walls	Plaster or GWB – painted
	Floor	Carpet
	Base	Rubber or vinyl
	Ceiling	Acoustical ceiling tile or painted GWB
Plumbing		
HVAC	Heating and cooling	
Fire Protection and Life Safety	Wet-pipe, automatic fire suppression sprinkler system	
Power	Standard power for office area	
Lighting	As required by UFC 3-530-01	
Communication	Telephone	One outlet per workstation
	Data	Two outlets per workstation (computer and printer)
	CCTV	
	CATV	
	Security	
Acoustics	NC 40	
Furnishings and Equipment	Freestanding systems furniture, as required	
Special Requirements		
	For use during project execution by the appropriate Service agency	
Occupancy	Staff	
	Other	
Min. net ft² (m²)		

Table 5-2.3 RACF – Private Offices

Description / Usage	Private office for select RACF positions.	
Ceiling Height	9'-0" minimum	
Windows	Recommended but not required	
Doors	Minimum 36" W x 80" H	
Interior Construction / Built-In Equipment		
Finishes	Walls	Plaster or GWB – painted
	Floor	Carpet
	Base	Rubber or vinyl
	Ceiling	Acoustical ceiling tile or painted GWB
Plumbing		
HVAC	Heating and cooling	
Fire Protection and Life Safety	Wet-pipe, automatic fire suppression sprinkler system	
Power	Standard power for office area	
Lighting	As required by UFC 3-530-01	
Communication	Telephone	One outlet
	Data	Two outlets (computer and printer)
	CCTV	
	CATV	
	Security	Lockable door with standard commercial-grade key lock
Acoustics	NC 35	
Furnishings and Equipment	Desk, chair, credenza/bookcase, filing cabinets and two (2) visitor chairs	
Special Requirements		
	For use during project execution by the appropriate Service agency	
Occupancy	Staff	
	Other	
Min. net ft² (m²)		

Table 5-2.4 RACF – Toilet Rooms with Lockers and Showers

Description / Usage	Men's and Women's Toilet Rooms	
Ceiling Height	9'-0" minimum	
Windows		
Doors	Minimum 36" W x 80" H	
Interior Construction / Built-In Equipment	Include lockers and recessed towel dispensers with integral waste receptacles. Provide half-height lockers (60% male, 40% female). In overseas locations, full-height must be provided.	
Finishes	Walls	Ceramic tile on moisture resistant GWB – full height
	Floor	Ceramic tile
	Base	Ceramic tile
	Ceiling	Acoustical ceiling tile or painted GWB
Plumbing	Water closets, urinals and lavatories with mirror. Include at least one shower and changing area in each toilet room.	
HVAC	Exhaust fan only.	
Fire Protection and Life Safety	Wet-pipe, automatic fire suppression sprinkler system	
Power	Standard power at lavatory with GFI outlets	
Lighting	As required by UFC 3-530-01	
Communication	Telephone	
	Data	
	CCTV	
	CATV	
	Security	Lockable door with bathroom lockset
Acoustics	NC 45	
Furnishings and Equipment		
Special Requirements	Provide separate restrooms adjacent to the Operations/IFR Room and the Break Room if space and budget allow.	
	For use during project execution by the appropriate Service agency	
Occupancy	Staff	
	Other	
Min. net ft² (m²)		

Table 5-2.5 RACF – Janitor Closet

Description / Usage	Space for custodial supplies and equipment	
Ceiling Height	Exposed structure. Provide 9'-0" minimum clear height.	
Windows		
Doors	Minimum 36" W x 80" H	
Interior Construction / Built-In Equipment	Include mop rack and storage shelving	
Finishes	Walls	48" H Ceramic tile wainscot on moisture resistant GWB – painted GWB above
	Floor	Ceramic tile or sealed concrete
	Base	Ceramic tile
	Ceiling	No ceiling required
Plumbing	One (1) custodial-style floor sink and floor drain	
HVAC	Exhaust fan only	
Fire Protection and Life Safety	Wet-pipe, automatic fire suppression sprinkler system	
Power	Standard power with GFI outlets	
Lighting	As required by UFC 3-530-01	
Communication	Telephone	
	Data	
	CCTV	
	CATV	
	Security	Lockable door with standard commercial-grade key lock
Acoustics	NC 50	
Furnishings and Equipment		
Special Requirements		
	For use during project execution by the appropriate Service agency	
Occupancy	Staff	
	Other	
Min. net ft² (m²)		

Table 5-2.6 RACF – Mechanical Room

Description / Usage	Room housing HVAC equipment for the RACF.	
Ceiling Height	Exposed structure. Minimum 7'-6" clear height	
Windows	Not required	
Doors	Minimum 36" W x 80" H	
Interior Construction / Built-In Equipment		
Finishes	Walls	CMU, plaster or GWB – painted
	Floor	Sealed concrete
	Base	
	Ceiling	No ceiling required
Plumbing	Floor sink required.	
HVAC	Heating and ventilation only.	
Fire Protection and Life Safety	Wet-pipe, automatic fire suppression sprinkler system	
Power	As required for mechanical equipment	
Lighting	As required by UFC 3-530-01	
Communication	Telephone	
	Data	
	CCTV	
	CATV	
	Security	Lockable door with standard commercial-grade key lock
Acoustics	NC 50	
Furnishings and Equipment	Mechanical HVAC equipment, as required.	
Special Requirements		
	For use during project execution by the appropriate Service agency	
Occupancy	Staff	
	Other	
Min. net ft² (m²)		

Table 5-2.7 RACF – Electrical Room

Description / Usage	Room housing electrical equipment for RACF.	
Ceiling Height	Exposed structure. Minimum 9'-0" clear height	
Windows	Not required	
Doors	Minimum 36" W x 80" H – interior and exterior access required	
Interior Construction / Built-In Equipment	UPS system is required	
Finishes	Walls	CMU, plaster or GWB – painted
	Floor	Sealed concrete
	Base	
	Ceiling	No ceiling required
Plumbing		
HVAC	Heating and ventilation as required for electrical equipment	
Fire Protection and Life Safety	Wet-pipe, automatic fire suppression sprinkler system	
Power	As required for electrical equipment. Include UPS system if required. Include grounding per FAA standard.	
Lighting	As required by UFC 3-530-01	
Communication	Telephone	
	Data	
	CCTV	
	CATV	
	Security	Lockable door with standard commercial-grade key lock
Acoustics	NC 50	
Furnishings and Equipment	Electrical equipment, as required.	
Special Requirements		
	For use during project execution by the appropriate Service agency	
Occupancy	Staff	
	Other	
Min. net ft2 (m2)		

Table 5-2.8 RACF – Telecommunications Room

Description / Usage	Telecommunications Frame Room housing the communications distribution plant for the RACF.	
Ceiling Height	Exposed structure. Minimum 9'-0" clear height	
Windows	Not required	
Doors	Minimum 36" W x 80" H	
Interior Construction / Built-In Equipment		
Finishes	Walls	Painted 3/4- inch fire-rated plywood, floor to ceiling, all walls.
	Floor	Sealed concrete
	Base	
	Ceiling	No ceiling required
Plumbing		
HVAC	Heating and cooling as required for telecommunications equipment	
Fire Protection and Life Safety	Wet-pipe, automatic fire suppression sprinkler system. Provide smoke detection.	
Power	Critical and non-critical power as required for telecommunications equipment. Include grounding per FAA standard.	
Lighting	As required by UFC 3-530-01	
Communication	Telephone	As required for telecommunications equipment
	Data	As required for telecommunications equipment
	CCTV	
	CATV	
	Security	Lockable door with standard commercial-grade key lock
Acoustics	NC 50	
Furnishings and Equipment	Telecommunications equipment, as required.	
Special Requirements	Multipoint ground system. Location of Main Distribution Frame (MDF) and ATC MDF enclosure.	
	For use during project execution by the appropriate Service agency	
Occupancy	Staff	
	Other	
Min. net ft² (m²)		

Table 5-2.9 RACF – TERPS/DSS Office

Description / Usage	Office responsible for actual planning and plotting of aircraft approach and ATC procedures	
Ceiling Height	9'-0" minimum	
Windows	Not required	
Doors		
Interior Construction / Built-In Equipment		
Finishes	Walls	Plaster or GWB – painted
	Floor	Carpet
	Base	Rubber or vinyl
	Ceiling	Acoustical ceiling tile or painted GWB
Plumbing		
HVAC	Heating and cooling	
Fire Protection and Life Safety	Wet-pipe, automatic fire suppression sprinkler system	
Power	Standard power for office area	
Lighting	As required by UFC 3-530-01	
Communication	Telephone	One outlet per workstation
	Data	Two outlets per workstation (computer and printer)
	CCTV	
	CATV	
	Security	
Acoustics	NC 40	
Furnishings and Equipment	Freestanding systems furniture for employee workstations. Also provide space for a large format plotter, drafting table, computer workstation, map storage drawers, and shelving for active Technical Orders.	
Special Requirements		
	For use during project execution by the appropriate Service agency	
Occupancy	Staff	
	Other	
Min. net ft² (m²)		

Table 5-2.10 RACF – Operations/Instrument Flight Rules (IFR) Room

Description / Usage	Room for controlling radar approach by aircraft, including a station for the Watch Supervisor, who oversees all scope activity. The Operations/IFR Room requires a considerable amount of circulation space.	
Ceiling Height	9'-0" minimum	
Windows	Not required	
Doors	36" W x 80" H minimum – double door access (48" W x 80" H) is required to the IFR Equipment Room – include narrow wire-glass lite in all doors	
Interior Construction / Built-In Equipment	Raised Access Flooring (RAF), fully grounded and bonded – Data cable tray installed below RAF	
Finishes	Walls	Plaster or GWB – painted with acoustical wall panels
	Floor	Static dissipative carpet
	Base	Rubber or vinyl
	Ceiling	Black (dyed) or white acoustical ceiling tile
Plumbing		
HVAC	CRITICAL AREA: Requires redundant heating and cooling	
Fire Protection and Life Safety	Wet-pipe, automatic fire suppression sprinkler system – special audible and visual alarm requirements – see <u>Section 4-2.6</u> . Provide smoke detection.	
Power	Critical power as required for ATC equipment and standard power for office area	
Lighting	Special requirements, see <u>Paragraph 4-2.7.8</u>	
Communication	Telephone	One outlet per workstation
	Data	Two outlets per workstation (computer and printer)
	CCTV	
	CATV	
	Security	Outside or inside entrance doors require cipher locks, cameras, intercoms, and electric door strikes
Acoustics	NC 40	
Furnishings and Equipment	Modular consoles for each controller position – provide ESD chairs that have metal frames with conductive casters and chair-covering material for controllers and supervisor – light curtain installed over cabinetry	
Special Requirements	Multipoint ground system. Doors between the Operations/IFR Room and the IFR Equipment Room must not be lockable.	
	For use during project execution by the appropriate Service agency	
Occupancy	Staff	
	Other	
Min. net ft² (m²)		

UFC 4-133-01
19 April 2016
Change 2, 25 June 2019

Table 5-2.11 RACF – Radar Simulator Room

Description / Usage	Room housing Radar simulators for controller training.	
Ceiling Height	9'-0" minimum	
Windows	Not required	
Doors	Minimum 36" W x 80" H	
Interior Construction / Built-In Equipment	Raised Access Flooring (RAF), fully grounded and bonded – Data cable tray installed below RAF	
Finishes	Walls	Plaster or GWB – painted
	Floor	Static dissipative carpet
	Base	Rubber or vinyl
	Ceiling	Black (dyed) or white acoustical ceiling tile
Plumbing		
HVAC	CRITICAL AREA: Requires redundant heating and cooling. May be on same system as Operations/IFR Room	
Fire Protection and Life Safety	Wet-pipe, automatic fire suppression sprinkler system	
Power	Critical power as required for simulator equipment and standard power for office area.	
Lighting	As required by UFC 3-530-01, with dimmable capability.	
Communication	Telephone	One outlet per simulator
	Data	Two outlets per simulator (computer and printer)
	CCTV	
	CATV	
	Security	Lockable door with standard commercial-grade key lock
Acoustics	NC 30	
Furnishings and Equipment	Simulator equipment, as required – provide ESD chairs that have metal frames with conductive casters and chair-covering material	
Special Requirements	Multipoint ground system.	
	For use during project execution by the appropriate Service agency	
Occupancy	Staff	
	Other	
Min. net ft² (m²)		

Table 5-2.12 RACF – ATCT Simulator Room

Description / Usage	Room housing ATCT simulator for controller training.	
Ceiling Height	9'-0" minimum	
Windows	Not required	
Doors	Minimum 36" W x 80" H	
Interior Construction / Built-In Equipment	Raised Access Flooring (RAF), fully grounded and bonded – Data cable tray installed below RAF	
Finishes	Walls	Plaster or GWB – painted
	Floor	Static dissipative carpet
	Base	Rubber or vinyl
	Ceiling	Acoustical ceiling tile or painted GWB
Plumbing		
HVAC	CRITICAL AREA: Requires redundant heating and cooling. May be on same system as Operations/IFR Room	
Fire Protection and Life Safety	Wet-pipe, automatic fire suppression sprinkler system	
Power	Critical power as required for simulator equipment and standard power for office area	
Lighting	As required by UFC 3-530-01, with dimmable capability	
Communication	Telephone	One outlet per workstation
	Data	Two outlets per workstation (computer and printer)
	CCTV	
	CATV	
	Security	Lockable door with standard commercial-grade key lock
Acoustics	NC 30	
Furnishings and Equipment	Simulator equipment, as required - provide ESD chairs that have metal frames with conductive casters and chair-covering material	
Special Requirements	Multipoint ground system.	
	For use during project execution by the appropriate Service agency	
Occupancy	Staff	
	Other	
Min. net ft² (m²)		

Table 5-2.13 RACF – Training Room

Description / Usage	Room housing the Computer-Based Instruction (CBI) component of RACF training. Locate adjacent to or near the Operations/IFR Room.	
Ceiling Height	9'-0" minimum	
Windows	Recommended but not required	
Doors	Minimum 36" W x 80" H	
Interior Construction / Built-In Equipment	White board, projector and motorized recessed projection screen. If a single large room is provided, consider a moveable partition to subdivide the space, allowing two individual sessions to be held at the same time.	
Finishes	Walls	Plaster or GWB – painted
	Floor	Carpet
	Base	Rubber or vinyl
	Ceiling	Acoustical ceiling tile or painted GWB
Plumbing		
HVAC	Heating and cooling	
Fire Protection and Life Safety	Wet-pipe, automatic fire suppression sprinkler system	
Power	Standard power for multiple computer workstations	
Lighting	As required by UFC 3-530-01	
Communication	Telephone	One outlet per workstation
	Data	Two outlets per workstation (computer and printer)
	CCTV	
	CATV	
	Security	Lockable door with standard commercial-grade key lock
Acoustics	NC 30	
Furnishings and Equipment	Freestanding furniture, as required. Typically contains between two and five computer workstations – provide ESD chairs that have metal frames with conductive casters and chair-covering material	
Special Requirements	May be combined with the RACF Briefing / Conference Room to reduce overall space requirements.	
	For use during project execution by the appropriate Service agency	
Occupancy	Staff	
	Other	
Min. net ft² (m²)		

Table 5-2.14 RACF – Briefing/Conference Room

Description / Usage	Room sized to house the entire RACF shift, plus the AOF/CC and the shift Watch Supervisor, for joint briefings and conferences. This space will be used by ATC and Maintenance personnel.	
Ceiling Height	9'-0" minimum	
Windows	Recommended but not required	
Doors	Minimum 36" W x 80" H	
Interior Construction / Built-In Equipment	White board, projector and motorized recessed projection screen. If a single large room is provided, consider a moveable partition to subdivide the space, allowing two individual sessions to be held at the same time.	
Finishes	Walls	Plaster or GWB – painted
	Floor	Carpet
	Base	Rubber or vinyl
	Ceiling	Acoustical ceiling tile or painted GWB
Plumbing		
HVAC	Heating and cooling	
Fire Protection and Life Safety	Wet-pipe, automatic fire suppression sprinkler system	
Power	Standard power for office-type areas	
Lighting	As required by UFC 3-530-01	
Communication	Telephone	One outlet minimum
	Data	Two outlets (computer and printer) minimum
	CCTV	
	CATV	
	Security	Lockable door with standard commercial-grade key lock
Acoustics	NC 35	
Furnishings and Equipment	Conference Table(s) and chairs on casters as required	
Special Requirements	May be combined with the RACF Training Room to reduce overall space requirements.	
	For use during project execution by the appropriate Service agency	
Occupancy	Staff	
	Other	
Min. net ft² (m²)		

Table 5-2.15 RACF – IFR Equipment Room

Description / Usage	Room housing communication racks that are the termination points for all lines entering and departing the RACF that provide data to and from the scopes in the Operations/IFR Room. Locate immediately adjacent to the Operations/IFR Room.	
Ceiling Height	9'-0" minimum	
Windows	Not required	
Doors	36" W x 80" H minimum – provide double door access (48" W x 80" H minimum) to the Operations/IFR Room(include narrow wire-glass lite in both doors) – provide double door access (48" W x 80" H minimum) to the exterior.	
Interior Construction / Built-In Equipment	Raised Access Flooring (RAF), fully grounded and bonded – Data cable tray installed below RAF.	
Finishes	Walls	Plaster or GWB – painted
	Floor	Static dissipative carpet or vinyl tile
	Base	Rubber or vinyl
	Ceiling	Acoustical ceiling tile or painted GWB
Plumbing		
HVAC	CRITICAL AREA: Requires redundant heating and cooling	
Fire Protection and Life Safety	Wet-pipe, automatic fire suppression sprinkler system. Provide smoke detection.	
Power	Critical power as required for ATC equipment and standard power for office area.	
Lighting	As required by UFC 3-530-01	
Communication	Telephone	One outlet
	Data	As required for ATC equipment
	CCTV	
	CATV	
	Security	Outside or inside entrance doors require cipher locks, door closers, and electric door strikes
Acoustics	NC 45	
Furnishings and Equipment	Communications racks and support equipment as required, including ESD workbenches, storage cabinets, shelving and chairs on casters.	
Special Requirements	Multipoint ground system. Doors between the Operations/IFR Room and the IFR Equipment Room must not be lockable. Location of ATC Circuit Intermediate Distribution Frame (IDF).	
	For use during project execution by the appropriate Service agency	
Occupancy	Staff	
	Other	
Min. net ft² (m²)		

Table 5-2.16 RACF – UPS Room

Description / Usage	Room housing the UPS system for the RACF.	
Ceiling Height	Exposed structure. Minimum 9'-0" clear height	
Windows	Not required	
Doors	Minimum 36" W x 80" H interior access door and a double door for exterior access as required	
Interior Construction / Built-In Equipment		
Finishes	Walls	CMU, plaster or GWB – painted
	Floor	Sealed concrete
	Base	
	Ceiling	No ceiling required
Plumbing		
HVAC	CRITICAL AREA: Requires redundant heating and cooling	
Fire Protection and Life Safety	Wet-pipe, automatic fire suppression sprinkler system	
Power	As required for UPS system equipment, include grounding per FAA Standard. Include EPO switch.	
Lighting	As required by UFC 3-530-01	
Communication	Telephone	
	Data	
	CCTV	
	CATV	
	Security	Lockable door with standard commercial-grade key lock
Acoustics	NC 50	
Furnishings and Equipment	UPS system equipment, as required.	
Special Requirements	Multipoint ground system. May be combined with the IFR Equipment Room or Electrical Room.	
	For use during project execution by the appropriate Service agency	
Occupancy	Staff	
	Other	
Min. net ft² (m²)		

Table 5-2.17 RACF – Storage Room

Description / Usage	Room for storage of general purpose materials.	
Ceiling Height	9'-0" minimum	
Windows	Not required	
Doors	Minimum 36" W x 80" H	
Interior Construction / Built-In Equipment	Full height walls for secure storage.	
Finishes	Walls	Plaster or GWB – painted
	Floor	VCT
	Base	Rubber or vinyl
	Ceiling	Acoustical ceiling tile or painted GWB
Plumbing		
HVAC	Heating and cooling	
Fire Protection and Life Safety	Wet-pipe, automatic fire suppression sprinkler system	
Power	Standard power for storage areas	
Lighting	As required by UFC 3-530-01	
Communication	Telephone	One outlet minimum
	Data	
	CCTV	
	CATV	
	Security	Lockable door with standard commercial-grade key locks
Acoustics	NC 40	
Furnishings and Equipment	Shelving and storage cabinets as required by user.	
Special Requirements		
	For use during project execution by the appropriate Service agency	
Occupancy	Staff	
	Other	
Min. net ft² (m²)		

Table 5-2.18 RACF – Flight Planning Room

Description / Usage	Open office area containing flight dispatch and flight planning operations.	
Ceiling Height	9'-0" minimum	
Windows	Recommended but not required	
Doors	Minimum 36" W x 80" H	
Interior Construction / Built-In Equipment	Provide eight (8) linear feet of counter open to hall or lobby. If required, provide Raised Access Flooring (RAF), fully grounded and bonded, with data cable tray installed below RAF.	
Finishes	Walls	Plaster or GWB – painted
	Floor	Static dissipative carpet
	Base	Rubber or vinyl
	Ceiling	Acoustical ceiling tile or painted GWB
Plumbing		
HVAC	Heating and cooling	
Fire Protection and Life Safety	Wet-pipe, automatic fire suppression sprinkler system	
Power	Critical power (UPS) as required for ATC electronic equipment and standard power for office area	
Lighting	As required by UFC 3-530-01	
Communication	Telephone	One outlet per workstation
	Data	Two outlets per workstation (computer and printer)
	CCTV	As required
	CATV	As required
	Security	
Acoustics	NC 40	
Furnishings and Equipment	Freestanding systems furniture, as required. ESD chairs on casters for operations personnel.	
Special Requirements	Multipoint ground system. Connectivity to IFR Equipment Room required.	
	For use during project execution by the appropriate Service agency	
Occupancy	Staff	
	Other	
Min. net ft² (m²)		

Table 5-2.19 RACF – Pilot Flight Planning Room

Description / Usage	Open office area containing flight planning operations.	
Ceiling Height	9'-0" minimum	
Windows	Recommended but not required	
Doors	Minimum 36" W x 80" H	
Interior Construction / Built-In Equipment		
Finishes	Walls	Plaster or GWB – painted
	Floor	Carpet.
	Base	Rubber or vinyl
	Ceiling	Acoustical ceiling tile or painted GWB
Plumbing		
HVAC	Heating and cooling	
Fire Protection and Life Safety	Wet-pipe, automatic fire suppression sprinkler system	
Power	Standard power for office area.	
Lighting	As required by UFC 3-530-01	
Communication	Telephone	One outlet per workstation
	Data	Two outlets per workstation (computer and printer)
	CCTV	
	CATV	
	Security	
Acoustics	NC 40	
Furnishings and Equipment	Freestanding systems furniture, as required.	
Special Requirements		
	For use during project execution by the appropriate Service agency	
Occupancy	Staff	
	Other	
Min. net ft² (m²)		

Table 5-2.20 RACF – ATC Equipment Maintenance Administration Area

Description / Usage	An open office area for administrative functions required for ATC equipment maintenance.	
Ceiling Height	9'-0" minimum	
Windows	Recommended but not required	
Doors	Minimum 36" W x 80" H	
Interior Construction / Built-In Equipment		
Finishes	Walls	Plaster or GWB – painted
	Floor	Carpet
	Base	Rubber or vinyl
	Ceiling	Acoustical ceiling tile or painted GWB
Plumbing		
HVAC	Heating and cooling	
Fire Protection and Life Safety	Wet-pipe, automatic fire suppression sprinkler system	
Power	Standard power for office area	
Lighting	As required by UFC 3-530-01	
Communication	Telephone	One outlet per workstation
	Data	Two outlets per workstation (computer and printer)
	CCTV	
	CATV	
	Security	
Acoustics	NC 40	
Furnishings and Equipment	Freestanding systems furniture, as required.	
Special Requirements		
	For use during project execution by the appropriate Service agency	
Occupancy	Staff	
	Other	
Min. net ft² (m²)		

Table 5-2.21 RACF – ATC Equipment Maintenance Area

Description / Usage	Room for maintenance of ATC equipment. Locate adjacent to the IFR Equipment Room with direct access to the Telecommunications Room.	
Ceiling Height	Minimum 9'-0" clear height	
Windows	Not required	
Doors	Minimum 36" W x 80" H	
Interior Construction / Built-In Equipment	Snorkel-type localized stand-alone exhaust system, as required.	
Finishes	Walls	CMU, plaster or GWB – painted
	Floor	Static dissipative VCT or carpet
	Base	
	Ceiling	Acoustical ceiling tile
Plumbing		
HVAC	Heating and cooling	
Fire Protection and Life Safety	Wet-pipe, automatic fire suppression sprinkler system	
Power	As required for maintenance equipment, include grounding per FAA Standard. TVSS required on the panel feeding this room.	
Lighting	As required by UFC 3-530-01	
Communication	Telephone	One outlet minimum
	Data	Two outlets (computer and printer) minimum
	CCTV	
	CATV	
	Security	Lockable door with standard commercial-grade key lock
Acoustics	NC 45	
Furnishings and Equipment	ESD Chairs on casters, ESD storage shelving, ESD cabinets, and ESD workbenches, as required.	
Special Requirements	Multipoint ground system. Locate adjacent to the IFR Equipment Room with direct access to the Telecommunications Room.	
	For use during project execution by the appropriate Service agency	
Occupancy	Staff	
	Other	
Min. net ft² (m²)		

Table 5-2.22 RACF – Break Room

Description / Usage	Room with a small kitchenette and seating accessible to trainees and RACF maintenance personnel as well as the on-duty controllers and administrative offices. Locate immediately adjacent to the Operations/IFR Room. Should also be accessible from the administrative office area.	
Ceiling Height	9'-0" minimum	
Windows	Recommended but not required	
Doors	Minimum 40" W x 80" H to provide access for vending machines.	
Interior Construction / Built-In Equipment	Base cabinets with plastic laminate countertop and wall cabinets above. Accommodate a wet sink.	
Finishes	Walls	Plaster or GWB – painted
	Floor	VCT
	Base	Rubber or vinyl
	Ceiling	Acoustical ceiling tile or painted GWB
Plumbing	Sink with hot and cold water	
HVAC	Heating and cooling	
Fire Protection and Life Safety	Wet-pipe, automatic fire suppression sprinkler system	
Power	Standard power with GFI outlets – provide outlet for wall-mounted television (if provided).	
Lighting	As required by UFC 3-530-01. Provide fully dimmable fixtures if located adjacent to the Operations/IFR Room.	
Communication	Telephone	One outlet
	Data	Yes
	CCTV	
	CATV	As required
	Security	Intercom
Acoustics	NC 40	
Furnishings and Equipment	Coffee service, refrigerator, microwave, a stove/range unit, and vending machines, along with seating and tables.	
Special Requirements	If a small break area, adjacent to the Operations/IFR Room, is provided for the controllers, another larger break room is required for the remainder of the facility. If approved, provide a stove/range unit with a filtered hood vented to the exterior.	
	For use during project execution by the appropriate Service agency	
Occupancy	Staff	
	Other	
Min. net ft² (m²)		

Table 5-2.23 RACF – 2M (Micro Miniature) Electronic Repair Room

Description / Usage	A room for Micro-Maintenance repair. Refer to NAVAIR 01-1A-23 for additional requirements.	
Ceiling Height	Minimum 9'-0" clear height	
Windows	Not required	
Doors	Minimum 36" W x 80" H	
Interior Construction / Built-In Equipment	Snorkel-type localized stand-alone exhaust system, as required.	
Finishes	Walls	CMU, plaster or GWB – painted
	Floor	Static dissipative VCT or carpet
	Base	
	Ceiling	Acoustical ceiling tile
Plumbing		
HVAC	Heating and cooling	
Fire Protection and Life Safety	Wet-pipe, automatic fire suppression sprinkler system	
Power	As required for maintenance equipment, include grounding per FAA Standard. TVSS required on the panel feeding this room.	
Lighting	As required by UFC 3-530-01	
Communication	Telephone	One outlet minimum
	Data	Two outlets (computer and printer) minimum
	CCTV	
	CATV	
	Security	Lockable door with standard commercial-grade key lock
Acoustics	NC 45	
Furnishings and Equipment	ESD Chairs on casters, ESD storage shelving, ESD cabinets, and ESD workbenches, as required.	
Special Requirements	Multipoint ground system. Locate adjacent to the IFR Equipment Room with direct access to the Telecommunications Room.	
	For use during project execution by the appropriate Service agency	
Occupancy	Staff	
	Other	
Min. net ft² (m²)		

Table 5-3.1 AOB – Lobby/Entry Vestibule

Description / Usage	Main entrance to AOB.	
Ceiling Height	9'-0" minimum	
Windows	Not required	
Doors	Minimum 36" W x 84" H opening, or as required by code – provide vestibule in cold weather areas	
Interior Construction / Built-In Equipment	Building directory and bulletin board	
Finishes	Walls	Plaster or GWB - painted
	Floor	Hard surface (terrazzo, VCT, etc.)
	Base	Terrazzo, rubber or vinyl
	Ceiling	Acoustical Ceiling Tile or Painted GWB
Plumbing		
HVAC	Heating and Cooling (heating only in vestibule)	
Fire Protection and Life Safety	Wet-pipe, automatic fire suppression sprinkler system	
Power	Standard power for office-type areas	
Lighting	As required by UFC 3-530-01	
Communication	Telephone	
	Data	
	CCTV	
	CATV	
	Security	Cipher lock and door closer at main entry door
Acoustics	NC 40	
Furnishings and Equipment		
Special Requirements	A covered or recessed entrance or vestibule is recommended.	
	For use during project execution by the appropriate Service agency	
Occupancy	Staff	
	Other	
Min. net ft² (m²)		

Table 5-3.2 AOB – HQ / Command Suite - Reception Area

Description / Usage	Open office area containing reception area for HQ / Command.	
Ceiling Height	9'-0" minimum	
Windows	Not required	
Doors	Minimum 36" W x 80" H	
Interior Construction / Built-In Equipment	Include visitor seating and coat closet	
Finishes	Walls	Plaster or GWB – painted
	Floor	Carpet
	Base	Rubber or vinyl
	Ceiling	Acoustical ceiling tile or painted GWB
Plumbing		
HVAC	Heating and cooling	
Fire Protection and Life Safety	Wet-pipe, automatic fire suppression sprinkler system	
Power	Standard power for office area	
Lighting	As required by UFC 3-530-01	
Communication	Telephone	One outlet per workstation
	Data	Two outlets per workstation (computer and printer)
	CCTV	
	CATV	
	Security	
Acoustics	NC 40	
Furnishings and Equipment	Freestanding systems furniture, as required.	
Special Requirements		
	For use during project execution by the appropriate Service agency	
Occupancy	Staff	
	Other	
Min. net ft² (m²)		

Table 5-3.3 AOB – HQ / Command Suite - Private Offices

Description / Usage	Private office for select HQ / Command positions.	
Ceiling Height	9'-0" minimum	
Windows	Recommended but not required	
Doors	Minimum 36" W x 80" H	
Interior Construction / Built-In Equipment		
Finishes	Walls	Plaster or GWB – painted
	Floor	Carpet
	Base	Rubber or vinyl
	Ceiling	Acoustical ceiling tile or painted GWB
Plumbing		
HVAC	Heating and cooling	
Fire Protection and Life Safety	Wet-pipe, automatic fire suppression sprinkler system	
Power	Standard power for office area	
Lighting	As required by UFC 3-530-01	
Communication	Telephone	One outlet
	Data	Two outlets (computer and printer)
	CCTV	
	CATV	As required
	Security	Lockable door with standard commercial-grade key lock
Acoustics	NC 35	
Furnishings and Equipment	Desk, chair, credenza/bookcase, filing cabinets and two (2) visitor chairs	
Special Requirements		
	For use during project execution by the appropriate Service agency	
Occupancy	Staff	
	Other	
Min. net ft² (m²)		

Table 5-3.4 AOB – Air Operations Duty Officer

Description / Usage	Reception area with counter.	
Ceiling Height	9'-0" minimum	
Windows	Recommended but not required	
Doors	Minimum 36" W x 80" H	
Interior Construction / Built-In Equipment		
Finishes	Walls	Plaster or GWB – painted
	Floor	Carpet
	Base	Rubber or vinyl
	Ceiling	Acoustical ceiling tile or painted GWB
Plumbing		
HVAC	Heating and cooling	
Fire Protection and Life Safety	Wet-pipe, automatic fire suppression sprinkler system	
Power	Standard power for office area	
Lighting	As required by UFC 3-530-01	
Communication	Telephone	One outlet per workstation
	Data	Two outlets per workstation (computer and printer)
	CCTV	
	CATV	
	Security	
Acoustics	NC 40	
Furnishings and Equipment	Freestanding systems furniture, as required.	
Special Requirements		
	For use during project execution by the appropriate Service agency	
Occupancy	Staff	
	Other	
Min. net ft² (m²)		

Table 5-3.5 AOB – Operations - Airfield Management/Flight Planning

Description / Usage	Open office area containing flight dispatch and flight planning operations.	
Ceiling Height	9'-0" minimum	
Windows	Recommended but not required	
Doors	Minimum 36" W x 80" H	
Interior Construction / Built-In Equipment	Provide eight (8) linear feet of counter open to hall or lobby. If required, provide Raised Access Flooring (RAF), fully grounded and bonded, with data cable tray installed below RAF.	
Finishes	Walls	Plaster or GWB – painted
	Floor	Static dissipative carpet
	Base	Rubber or vinyl
	Ceiling	Acoustical ceiling tile or painted GWB
Plumbing		
HVAC	Heating and cooling	
Fire Protection and Life Safety	Wet-pipe, automatic fire suppression sprinkler system	
Power	Critical power (UPS) as required for ATC electronic equipment and standard power for office area	
Lighting	As required by UFC 3-530-01	
Communication	Telephone	One outlet per workstation
	Data	Two outlets per workstation (computer and printer)
	CCTV	As required
	CATV	As required
	Security	
Acoustics	NC 40	
Furnishings and Equipment	Freestanding systems furniture, as required. ESD chairs on casters for operations personnel.	
Special Requirements	Multipoint ground system. Connectivity to IFR Equipment Room required.	
	For use during project execution by the appropriate Service agency	
Occupancy	Staff	
	Other	
Min. net ft² (m²)		

Table 5-3.6 AOB – Operations – Pilot Flight Planning Room

Description / Usage	Open office area containing flight planning operations.	
Ceiling Height	9'-0" minimum	
Windows	Recommended but not required	
Doors	Minimum 36" W x 80" H	
Interior Construction / Built-In Equipment		
Finishes	Walls	Plaster or GWB – painted
	Floor	Carpet.
	Base	Rubber or vinyl
	Ceiling	Acoustical ceiling tile or painted GWB
Plumbing		
HVAC	Heating and cooling	
Fire Protection and Life Safety	Wet-pipe, automatic fire suppression sprinkler system	
Power	Standard power for office area.	
Lighting	As required by UFC 3-530-01	
Communication	Telephone	One outlet per workstation
	Data	Two outlets per workstation (computer and printer)
	CCTV	
	CATV	
	Security	
Acoustics	NC 40	
Furnishings and Equipment	Freestanding systems furniture, as required.	
Special Requirements		
	For use during project execution by the appropriate Service agency	
Occupancy	Staff	
	Other	
Min. net ft² (m²)		

Table 5-3.7 AOB – Operations – Weather Station

Description / Usage	Open office area containing weather station operations.	
Ceiling Height	9'-0" minimum	
Windows	Recommended but not required	
Doors	Minimum 36" W x 80" H	
Interior Construction / Built-In Equipment		
Finishes	Walls	Plaster or GWB – painted
	Floor	Static dissipative carpet
	Base	Rubber or vinyl
	Ceiling	Acoustical ceiling tile or painted GWB
Plumbing		
HVAC	Heating and cooling	
Fire Protection and Life Safety	Wet-pipe, automatic fire suppression sprinkler system	
Power	Critical power is required for the Weather electronic equipment and standard power for office area. TVSS required on the panel feeding this room.	
Lighting	As required by UFC 3-530-01	
Communication	Telephone	One outlet per workstation
	Data	Two outlets per workstation (computer and printer)
	CCTV	
	CATV	
	Security	
Acoustics	NC 40	
Furnishings and Equipment	Freestanding systems furniture, as required.	
Special Requirements	Multipoint ground system.	
	For use during project execution by the appropriate Service agency	
Occupancy	Staff	
	Other	
Min. net ft² (m²)		

Table 5-3.8 AOB – Operations – Pilot Ready Room

Description / Usage	Open office area containing pilot ready room.	
Ceiling Height	9'-0" minimum	
Windows	Recommended but not required	
Doors	Minimum 36" W x 80" H	
Interior Construction / Built-In Equipment		
Finishes	Walls	Plaster or GWB – painted
	Floor	Carpet
	Base	Rubber or vinyl
	Ceiling	Acoustical ceiling tile or painted GWB
Plumbing		
HVAC	Heating and cooling	
Fire Protection and Life Safety	Wet-pipe, automatic fire suppression sprinkler system	
Power	Standard power for office area	
Lighting	As required by UFC 3-530-01	
Communication	Telephone	One outlet per workstation
	Data	Two outlets per workstation (computer and printer)
	CCTV	
	CATV	
	Security	
Acoustics	NC 40	
Furnishings and Equipment	Freestanding systems furniture, as required.	
Special Requirements		
	For use during project execution by the appropriate Service agency	
Occupancy	Staff	
	Other	
Min. net ft² (m²)		

Table 5-3.9 AOB – Airfield Services – Open Office Area

Description / Usage	Open office area containing airfield services operations.	
Ceiling Height	9'-0" minimum	
Windows	Recommended but not required	
Doors	Minimum 36" W x 80" H	
Interior Construction / Built-In Equipment		
Finishes	Walls	Plaster or GWB – painted
	Floor	Carpet
	Base	Rubber or vinyl
	Ceiling	Acoustical ceiling tile or painted GWB
Plumbing		
HVAC	Heating and cooling	
Fire Protection and Life Safety	Wet-pipe, automatic fire suppression sprinkler system	
Power	Standard power for office area	
Lighting	As required by UFC 3-530-01	
Communication	Telephone	One outlet per workstation
	Data	Two outlets per workstation (computer and printer)
	CCTV	
	CATV	
	Security	
Acoustics	NC 40	
Furnishings and Equipment	Freestanding systems furniture, as required.	
Special Requirements		
	For use during project execution by the appropriate Service agency	
Occupancy	Staff	
	Other	
Min. net ft² (m²)		

Table 5-3.10 AOB – Airfield Services – Printer/Copier Station

Description / Usage	Room containing shared printers and copiers for airfield services.	
Ceiling Height	9'-0" minimum	
Windows	Recommended but not required	
Doors	Minimum 36" W x 80" H	
Interior Construction / Built-In Equipment	Base cabinets with plastic laminate countertop and wall cabinets above.	
Finishes	Walls	Plaster or GWB – painted
	Floor	Carpet or VCT
	Base	Rubber or vinyl
	Ceiling	Acoustical ceiling tile or painted GWB
Plumbing		
HVAC	Heating and cooling	
Fire Protection and Life Safety	Wet-pipe, automatic fire suppression sprinkler system	
Power	As required for printers and copiers. Provide standard outlets along countertop for portable equipment.	
Lighting	As required by UFC 3-530-01	
Communication	Telephone	One outlet minimum
	Data	As required for printers and copiers
	CCTV	
	CATV	
	Security	Lockable cabinets
Acoustics	NC 45	
Furnishings and Equipment		
Special Requirements		
	For use during project execution by the appropriate Service agency	
Occupancy	Staff	
	Other	
Min. net ft² (m²)		

Table 5-3.11 AOB – Non-Sensitive Secure Storage Room

Description / Usage	Room for storage of non-sensitive materials.	
Ceiling Height	9'-0" minimum	
Windows	Not required	
Doors	Minimum 36" W x 80" H	
Interior Construction / Built-In Equipment	Full height walls for secure storage. Room construction must comply with service specific requirements.	
Finishes	Walls	Plaster or GWB – painted
	Floor	VCT
	Base	Rubber or vinyl
	Ceiling	Acoustical ceiling tile or painted GWB
Plumbing		
HVAC	Heating and cooling	
Fire Protection and Life Safety	Wet-pipe, automatic fire suppression sprinkler system	
Power	Standard power for storage areas	
Lighting	As required by UFC 3-530-01	
Communication	Telephone	One outlet minimum
	Data	
	CCTV	
	CATV	
	Security	
Acoustics	NC 40	
Furnishings and Equipment	Shelving and storage cabinets as required by user.	
Special Requirements		
	For use during project execution by the appropriate Service agency	
Occupancy	Staff	
	Other	
Min. net ft² (m²)		

Table 5-3.12 AOB – General Purpose Storage Room

Description / Usage	Room for storage of general purpose materials.	
Ceiling Height	9'-0" minimum	
Windows	Not required	
Doors	Minimum 36" W x 80" H	
Interior Construction / Built-In Equipment	Full height walls for secure storage.	
Finishes	Walls	Plaster or GWB – painted
	Floor	VCT
	Base	Rubber or vinyl
	Ceiling	Acoustical ceiling tile or painted GWB
Plumbing		
HVAC	Heating and cooling	
Fire Protection and Life Safety	Wet-pipe, automatic fire suppression sprinkler system	
Power	Standard power for storage areas	
Lighting	As required by UFC 3-530-01	
Communication	Telephone	One outlet minimum
	Data	
	CCTV	
	CATV	
	Security	Lockable door with standard commercial-grade key locks
Acoustics	NC 40	
Furnishings and Equipment	Shelving and storage cabinets as required by user.	
Special Requirements		
	For use during project execution by the appropriate Service agency	
Occupancy	Staff	
	Other	
Min. net ft² (m²)		

Table 5-3.13 AOB – File Storage Area

Description / Usage	Room for file storage.	
Ceiling Height	9'-0" minimum	
Windows	Not required	
Doors	Minimum 36" W x 80" H	
Interior Construction / Built-In Equipment	Full height walls for secure storage.	
Finishes	Walls	Plaster or GWB – painted
	Floor	VCT
	Base	Rubber or vinyl
	Ceiling	Acoustical ceiling tile or painted GWB
Plumbing		
HVAC	Heating and cooling	
Fire Protection and Life Safety	Wet-pipe, automatic fire suppression sprinkler system	
Power	Standard power for storage areas	
Lighting	As required by UFC 3-530-01	
Communication	Telephone	One outlet minimum
	Data	
	CCTV	
	CATV	
	Security	Lockable door with standard commercial-grade key locks
Acoustics	NC 40	
Furnishings and Equipment	Shelving and storage cabinets as required by user.	
Special Requirements		
	For use during project execution by the appropriate Service agency	
Occupancy	Staff	
	Other	
Min. net ft² (m²)		

Table 5-3.14 AOB – ATC Equipment Maintenance Administration Area

Description / Usage	Open office area containing systems furniture workstations	
Ceiling Height	9'-0" minimum	
Windows	Not required	
Doors		
Interior Construction / Built-In Equipment		
Finishes	Walls	Plaster or GWB – painted
	Floor	Carpet
	Base	Rubber or vinyl
	Ceiling	Acoustical ceiling tile or painted GWB
Plumbing		
HVAC	Heating and cooling	
Fire Protection and Life Safety	Wet-pipe, automatic fire suppression sprinkler system	
Power	Standard power for office area	
Lighting	As required by UFC 3-530-01	
Communication	Telephone	One outlet per workstation
	Data	Two outlets per workstation (computer and printer)
	CCTV	
	CATV	
	Security	
Acoustics	NC 40	
Furnishings and Equipment	Freestanding systems furniture, as required	
Special Requirements		
	For use during project execution by the appropriate Service agency	
Occupancy	Staff	
	Other	
Min. net ft² (m²)		

Table 5-3.15 AOB – ATC Equipment Maintenance Area

Description / Usage	Room for maintenance of ATC electronic equipment. Include general purpose storage room, non-sensitive secure storage room, and file storage area.	
Ceiling Height	9'-0" minimum	
Windows	Recommended but not required	
Doors	Minimum 36" W x 80" H – interior; minimum 36" W x 80" H exterior door access; confirm opening requirement with local ATC equipment maintenance personnel.	
Interior Construction / Built-In Equipment	Snorkel-type localized stand-alone exhaust system, as required.	
Finishes	Walls	CMU, plaster or GWB – painted
	Floor	Static dissipative VCT or carpet
	Base	Rubber or vinyl
	Ceiling	Acoustical ceiling tile or painted GWB
Plumbing	Plumbed emergency eye wash station, as required.	
HVAC	Heating and cooling	
Fire Protection and Life Safety	Wet-pipe, automatic fire suppression sprinkler system	
Power	As required for maintenance equipment, include grounding per FAA Standard. TVSS required on the panel feeding this room.	
Lighting	As required by UFC 3-530-01	
Communication	Telephone	One outlet minimum
	Data	Two outlets (computer and printer) minimum
	CCTV	
	CATV	
	Security	Lockable door with standard commercial-grade key lock
Acoustics	NC 45	
Furnishings and Equipment	General purpose workstations, ESD Chairs on casters, ESD storage shelving, ESD cabinets, and ESD workbenches, as required.	
Special Requirements	Multipoint ground system.	
	For use during project execution by the appropriate Service agency	
Occupancy	Staff	
	Other	
Min. net ft² (m²)		

Table 5-3.16 AOB – Break Area

Description / Usage	Room with a small kitchenette and seating accessible to all occupants of the AOB.	
Ceiling Height	9'-0" minimum	
Windows	Recommended but not required	
Doors	Minimum 42" W x 80" H for vending machine access. Coordinate vending machine installation route.	
Interior Construction / Built-In Equipment	Base cabinets with plastic laminate countertop and wall cabinets above. Accommodate a wet sink.	
Finishes	Walls	Plaster or GWB – painted
	Floor	VCT or ceramic tile
	Base	Rubber or vinyl
	Ceiling	Acoustical ceiling tile or painted GWB
Plumbing	Sink with hot and cold water	
HVAC	Heating and cooling	
Fire Protection and Life Safety	Wet-pipe, automatic fire suppression sprinkler system	
Power	Standard power with GFI outlets – provide outlet for wall-mounted television (if provided).	
Lighting	As required by UFC 3-530-01	
Communication	Telephone	One outlet
	Data	
	CCTV	
	CATV	
	Security	Lockable cabinets
Acoustics	NC 40	
Furnishings and Equipment	Coffee service, refrigerator, microwave, and vending machines, as well as seating and tables	
Special Requirements	If approved, provide a stove/range unit with a filtered hood vented to the exterior.	
	For use during project execution by the appropriate Service agency	
Occupancy	Staff	
	Other	
Min. net ft² (m²)		

Table 5-3.17 AOB – Multipurpose Room

Description / Usage	Multipurpose room for conferences and training sessions.	
Ceiling Height	9'-0" minimum	
Windows	Recommended but not required	
Doors	Minimum 36" W x 80" H (provide two if a moveable partition is provided)	
Interior Construction / Built-In Equipment	White board, projector and motorized recessed projection screen. If a single large room is provided, consider a moveable partition to subdivide the space, allowing two individual sessions to be held at the same time.	
Finishes	Walls	Plaster or GWB – painted
	Floor	Carpet
	Base	Rubber or vinyl
	Ceiling	Acoustical ceiling tile or painted GWB
Plumbing		
HVAC	Heating and cooling	
Fire Protection and Life Safety	Wet-pipe, automatic fire suppression sprinkler system	
Power	Standard power for office-type areas	
Lighting	As required by UFC 3-530-01	
Communication	Telephone	One outlet minimum (two if a moveable partition is provided)
	Data	Two outlets (computer and printer) minimum (four if a moveable partition is provided)
	CCTV	
	CATV	As required
	Security	Lockable door(s) with standard commercial-grade key lock
Acoustics	NC 35	
Furnishings and Equipment	Conference table(s) and chairs on casters, as required.	
Special Requirements		
	For use during project execution by the appropriate Service agency	
Occupancy	Staff	
	Other	
Min. net ft² (m²)		

Table 5-3.18 AOB – Male and Female Toilet Rooms

Description / Usage	Men's and Women's Toilet Rooms	
Ceiling Height	9'-0" minimum	
Windows		
Doors	Minimum 36" W x 80" H	
Interior Construction / Built-In Equipment	Include lockers and recessed towel dispensers with integral waste receptacles.	
Finishes	Walls	Ceramic Tile on moisture resistant GWB – full height
	Floor	Ceramic Tile
	Base	Ceramic Tile
	Ceiling	Acoustical ceiling tile or painted GWB
Plumbing	Water closets, urinals and lavatories with mirror. Include at least one shower and changing area in each toilet room.	
HVAC	Exhaust fan only	
Fire Protection and Life Safety	Wet-pipe, automatic fire suppression sprinkler system	
Power	Standard power at lavatory with GFI outlets	
Lighting	As required by UFC 3-530-01	
Communication	Telephone	
	Data	
	CCTV	
	CATV	
	Security	Lockable door with bathroom lockset
Acoustics	NC 45	
Furnishings and Equipment		
Special Requirements		
	For use during project execution by the appropriate Service agency	
Occupancy	Staff	
	Other	
Min. net ft2 (m2)		

Table 5-3.19 AOB – Janitor Closet

Description / Usage	Room for custodial supplies and equipment.	
Ceiling Height	Exposed structure. Provide 9'-0" minimum clear height.	
Windows		
Doors	Minimum 36" W x 80" H	
Interior Construction / Built-In Equipment	Include mop rack and storage shelving	
Finishes	Walls	48"H Ceramic Tile wainscot on moisture resistant GWB – painted GWB above
	Floor	Ceramic Tile or Sealed Concrete
	Base	Ceramic Tile
	Ceiling	No ceiling required
Plumbing	One (1) custodial-style floor sink	
HVAC	Exhaust fan only	
Fire Protection and Life Safety	Wet-pipe, automatic fire suppression sprinkler system	
Power	Standard power with GFI outlets	
Lighting	As required by UFC 3-530-01	
Communication	Telephone	
	Data	
	CCTV	
	CATV	
	Security	Lockable door with standard commercial-grade key lock
Acoustics	NC 50	
Furnishings and Equipment		
Special Requirements		
	For use during project execution by the appropriate Service agency	
Occupancy	Staff	
	Other	
Min. net ft2 (m2)		

Table 5-3.20 AOB – Mechanical Room

Description / Usage	Room housing HVAC equipment for the AOB.	
Ceiling Height	Exposed structure. Minimum 9'-0" clear height	
Windows	Not required	
Doors	Minimum 36" W x 80" H	
Interior Construction / Built-In Equipment		
Finishes	Walls	CMU, plaster or GWB – painted
	Floor	Sealed concrete
	Base	
	Ceiling	No ceiling required
Plumbing	Floor sink required.	
HVAC	Heating and ventilation only	
Fire Protection and Life Safety	Wet-pipe, automatic fire suppression sprinkler system	
Power	As required for mechanical equipment	
Lighting	As required by UFC 3-530-01	
Communication	Telephone	
	Data	
	CCTV	
	CATV	
	Security	Lockable door with standard commercial-grade key lock
Acoustics	NC 50	
Furnishings and Equipment	Mechanical HVAC equipment, as required.	
Special Requirements		
	For use during project execution by the appropriate Service agency	
Occupancy	Staff	
	Other	
Min. net ft2 (m2)		

Table 5-3.21 AOB – Electrical Room

Description / Usage	Room housing electrical equipment for AOB.	
Ceiling Height	Exposed structure. Minimum 9'-0" clear height	
Windows	Not required	
Doors	Minimum 36" W x 80" H – interior and exterior access required	
Interior Construction / Built-In Equipment		
Finishes	Walls	CMU, plaster or GWB – painted
	Floor	Sealed concrete
	Base	
	Ceiling	No ceiling required
Plumbing		
HVAC	Heating and cooling as required for electrical equipment	
Fire Protection and Life Safety	Wet-pipe, automatic fire suppression sprinkler system	
Power	As required for electrical equipment	
Lighting	As required by UFC 3-530-01	
Communication	Telephone	
	Data	
	CCTV	
	CATV	
	Security	Lockable door with standard commercial-grade key lock
Acoustics	NC 50	
Furnishings and Equipment	Electrical equipment, as required.	
Special Requirements		
	For use during project execution by the appropriate Service agency	
Occupancy	Staff	
	Other	
Min. net ft2 (m2)		

Table 5-3.22 AOB – Telecommunications Room

Description / Usage	Telephone / Data Communications Frame Room housing the communications distribution plant for the AOB.	
Ceiling Height	Exposed structure. Minimum 9'-0" clear height	
Windows	Not required	
Doors	Minimum 36" W x 80" H	
Interior Construction / Built-In Equipment		
Finishes	Walls	Painted 3/4 inch fire rated plywood, floor to ceiling, all walls
	Floor	Sealed concrete
	Base	
	Ceiling	No ceiling required
Plumbing		
HVAC	Heating and cooling as required for telecommunications equipment	
Fire Protection and Life Safety	Wet-pipe, automatic fire suppression sprinkler system. Provide smoke detection.	
Power	As required for telecommunications equipment	
Lighting	As required by UFC 3-530-01	
Communication	Telephone	As required for telecommunications equipment
	Data	As required for telecommunications equipment
	CCTV	
	CATV	
	Security	Lockable door with standard commercial-grade key lock
Acoustics	NC 50	
Furnishings and Equipment	Telecommunications equipment, as required.	
Special Requirements		
	For use during project execution by the appropriate Service agency	
Occupancy	Staff	
	Other	
Min. net ft² (m²)		

Table 5-3.23 AOB – SIPR Room

Description / Usage	For certain facilities, a room for SIPR equipment must be provided.	
Ceiling Height	Exposed structure. Minimum 9'-0" clear height	
Windows	Not required	
Doors	Minimum 36" W x 80" H	
Interior Construction / Built-In Equipment		
Finishes	Walls	Painted 3/4 inch fire rated plywood, floor to ceiling, all walls
	Floor	Sealed concrete
	Base	
	Ceiling	No ceiling required
Plumbing		
HVAC	Heating and cooling as required for SIPR equipment	
Fire Protection and Life Safety	Wet-pipe, automatic fire suppression sprinkler system	
Power	As required for SIPR equipment	
Lighting	As required by UFC 3-530-01	
Communication	Telephone	As required
	Data	As required
	CCTV	
	CATV	
	Security	Lockable door with standard commercial-grade key lock
Acoustics	NC 50	
Furnishings and Equipment	SIPR equipment, as required.	
Special Requirements		
	For use during project execution by the appropriate Service agency	
Occupancy	Staff	
	Other	
Min. net ft² (m²)		

Table 5-3.24 AOB – Outside Covered Storage Area

Description / Usage	One (1) outside storage building and one (1) outside covered storage area with fence and lockable gate. The storage area is used to store airfield services related equipment and must have direct access to the parking aprons	
Ceiling Height	Exposed structure. Minimum 12'-0" clear height	
Windows		
Doors		
Interior Construction / Built-In Equipment		
Finishes	Walls	
	Floor	Sealed concrete
	Base	
	Ceiling	No ceiling required
Plumbing		
HVAC		
Fire Protection and Life Safety		
Power	As required for overhead lighting and convenience power	
Lighting	As required by UFC 3-530-01	
Communication	Telephone	
	Data	
	CCTV	
	CATV	
	Security	
Acoustics		
Furnishings and Equipment		
Special Requirements		
	For use during project execution by the appropriate Service agency	
Occupancy	Staff	
	Other	
Min. net ft² (m²)		

Table 5-3.25 AOB – Transient Passenger Services

Description / Usage	Waiting area for transient passengers.	
Ceiling Height	9'-0" minimum	
Windows	Recommended but not required	
Doors	Minimum 36" W x 80" H	
Interior Construction / Built-In Equipment		
Finishes	Walls	Plaster or GWB – painted
	Floor	Carpet
	Base	Rubber or vinyl
	Ceiling	Acoustical ceiling tile or painted GWB
Plumbing		
HVAC	Heating and cooling	
Fire Protection and Life Safety	Wet-pipe, automatic fire suppression sprinkler system.	
Power	Standard power for office-type areas. Provide adequate USB charging outlets.	
Lighting	As required by UFC 3-530-01	
Communication	Telephone	One outlet minimum
	Data	Wireless internet access
	CCTV	
	CATV	Yes
	Security	
Acoustics	NC 40	
Furnishings and Equipment	Seating as required by program.	
Special Requirements		
	For use during project execution by the appropriate Service agency	
Occupancy	Staff	
	Other	
Min. net ft² (m²)		

Table 5-3.26 AOB – VIP Passenger Services

Description / Usage	Waiting area for VIPs.	
Ceiling Height	9'-0" minimum	
Windows	Recommended but not required	
Doors	Minimum 36" W x 80" H	
Interior Construction / Built-In Equipment		
Finishes	Walls	Plaster or GWB – painted
	Floor	Carpet
	Base	Rubber or vinyl
	Ceiling	Acoustical ceiling tile or painted GWB
Plumbing		
HVAC	Heating and cooling	
Fire Protection and Life Safety	Wet-pipe, automatic fire suppression sprinkler system	
Power	Standard power for office-type areas. Provide adequate USB charging outlets.	
Lighting	As required by UFC 3-530-01	
Communication	Telephone	One outlet minimum
	Data	Yes
	CCTV	
	CATV	Yes
	Security	
Acoustics	NC 40	
Furnishings and Equipment	Seating as required by program.	
Special Requirements		
	For use during project execution by the appropriate Service agency	
Occupancy	Staff	
	Other	
Min. net ft² (m²)		

This Page Intentionally Left Blank

APPENDIX A REFERENCES

A-1 GOVERNMENT PUBLICATIONS

UNIFIED FACILITIES CRITERIA (UFC)

http://www.wbdg.org/ccb/browse_cat.php?o=29&c=4

UFC 1-200-01, *General Building Requirements*

UFC 3-120-01, *Air Force Sign Standard* (to be superseded by unified version)

UFC 3-210-02, *POV Site Circulation and Parking*

UFC 3-250-01FA, *Pavement Design for Roads, Streets, Walks and Open Storage Areas*

UFC 3-260-01, *Airfield and Heliport Design and Planning*

UFC 3-260-02, *Pavement Design for Airfields*

UFC 3-460-01, *Design: Petroleum Fuel Facilities*

UFC 3-535-01, *Visual Air Navigation Facilities*

UFC 3-555-01N, *400 Hertz Medium Voltage Conversion / Distribution and Low Voltage Utilization Systems*

UFC 4-020-01, *DoD Security Engineering Facilities Planning Manual*

UFC 4-020-02, *DoD Security Engineering Facilities Design Manual*, currently in Draft and unavailable

UFC 4-021-02, *Electronic Security Systems*

UFC 4-023-03, *Design of Buildings to Resist Progressive Collapse*

UFGS 08 81 00, *Glazing*

NAVY

http://www.wbdg.org/ccb/browse_org.php?o=30 or www.navfac.navy.mil

ITG 2013-01, *NAVFAC Elevator Design Guide*

MIL-HDBK-419A Vol. 1 & 2 of 29 December 1987, *Grounding, Bonding, and Shielding Requirements for Electronic Equipment and Facilities*

MIL-HDBK-1012/1, *Electronic Facilities Engineering*

MIL-HDBK-1013/1A, *Design Guidelines for Physical Security of Facilities*

MIL-HDBK-1195, *Radio Frequency Shielded Enclosures*

NAVFACINST 11010.45, *Regional Planning Instruction*

NAVSEA OP 3565/NAVAIR 16-1-529 of 01 May 2002, Volume 1, *Electromagnetic Radiation Hazards to Personnel, Fuel and Other Flammable Material*; and Volume 2, *Electromagnetic Radiation Hazards to Ordnance*.

NAVAIR 00-80T-114 of 15 September 2006, *Naval Air Training and Operating Procedures Standardization (NATOPS) Air Traffic Control Manual*

NAVAIR 01-1A-23, *Standard Maintenance Practices Miniature/Microminiature (2M) Electronic Assembly Repair*, 1 October 2006

NAVAIR 51-50AAA-2, *General Requirements for Shore Based Airfield Marking and Lighting*, Feb 2009

OPNAVINST 5100.23G of 30 December 2005, *Navy Safety and Occupational Health (NAVSOH) Program Manual*

SPACE AND NAVAL WARFARE SYSTEMS COMMAND (SPAWAR)

<http://enterprise.spawar.navy.mil>

SPAWARINST 2804.1, *Policy and Procedures Concerning Base Electronic Systems Engineering Plan*

U.S. AIR FORCE (USAF)

http://www.wbdg.org/ccb/browse_org.php?o=33 or <http://www.e-publishing.af.mil>

AFMAN 32-1084, *Facilities Requirements*

AFI 13-204v1, *Airfield Operations Career Field Development*

AFI 13-204v2, *Airfield Operations Standardization and Evaluations*

AFI 13-204v3, *Airfield Operations Procedures and Programs*

AFI 31-101, *Protection of Controlled Areas*

AFI 32-1044, *Visual Air Navigation Systems*

AFI 32-1054, *Corrosion Control*

AFI 32-1062, *Electric Power Plants and Generators*

AFI 32-1063, *Electric Power Systems*

AFI 32-1065, *Grounding Systems*

AFJMAN 32-1070, Chapter 4, *Plumbing* (Army TM 5-810-5)

AFJMAN 32-1083, *Electrical Interior Facilities Engineering* (Army TM 5-683)

AFMAN 32-7046, *Engineering Weather Data*

AFPD 13-2, *Air Traffic Control, Airspace, Airfield, and Range Management*

AFPD 32-10, *Installations and Facilities*

ETL 02-12, *Communications and Information System Criteria for Air Force Facilities*

ETL 01-1, *Reliability and Maintainability (R&M) Design Checklist*

ETL 01-18, *Fire Protection Engineering Criteria – Electronic Equipment Installations*

USAF Landscape Design Guide

USAF Project Manager's Guide for Design and Construction

Tower Simulation System (TSS) Facility Design Criteria by ADACEL, March 24, 2003

U.S. ARMY CORPS OF ENGINEERS (USACE)

http://www.wbdg.org/ccb/browse_org.php?o=31 or <http://www.hnd.usace.army.mil/techinfo/>

AR 95-2, *Airspace, Airfields/Heliports, Flight Activities, Air Traffic Control, and Navigational Aids*

AR 190-16, *Physical Security*

AR 190-51, *Security of Unclassified Army Property*

AR 210-20, *Real Property Master Planning for Army Installations*

AR 380-5, *Department of the Army Information Security Program*

AR 420-1, *Army Facilities Management*

DA PAM 415-28, *Guide to Army Real Property Category Codes*

ETL 1110-3-491, *Engineering & Design: Sustainable Design for Military Facilities*

TC 3-04.81, *ATC Facility Operations, Training, Maintenance and Standardization*

FEDERAL AVIATION ADMINISTRATION (FAA)

www.faa.gov

FAA Order 6480.4a, *ATCT Siting Criteria*

FAA Order 6480.7e of 11 August 2004, *Airport Traffic Control Tower and Terminal Radar Approach Control (TRACON) Facility Design Guidelines*

FAA Order 6480.18 of 3 April 1986, *Standard Specification for Transparent Plastic Window Shades for use in ATCT Cabs*

FAA Order 6950.19a of 01 July 1996, *Practices and Procedures For Lightning Protection, Grounding, Bonding, and Shielding Implementation*

FAA Order 6950.20 of 28 July 1978, *Fundamental Considerations of Lightning Protection, Grounding, Bonding, and Shielding*

FAA Order 6950.27, *Short Circuit Analysis and Protective Device Coordination Study*

FAA Specification C-1217, *Electrical Work Interior*

FAA Specification E-2470b of 05 December 1985, *Transparent Plastic Window Shades*

FAA-ANI-300-380, *Transparent Plastic Window Shades*

FAA Advisory Circular AC 70/7460, *Obstruction Marking and Lighting*

FAA Advisory Circular AC 150/5345-43F of 12 September 2006, *Specification For Obstruction Lighting Equipment*

FAA Advisory Circular AC 150/5345-3G of 9 September 2010, *Specification for L-821 Panels for Remote Control of Airport Lighting*

FAA-STD-019e of 22 December 2005, *Lightning and Surge Protection, Grounding, Bonding and Shielding Requirements for Facilities*

FAA-STD-020b, *Transient Protection, Grounding, Bonding and Shielding Requirements for Electronic Equipment*

FEDERAL INFORMATION PROCESSING STANDARDS (FIPS)

www.fips.gov

FIPS PUB 94, *Guideline on Electrical Power for ADP Installations*

CODE OF FEDERAL REGULATIONS (CFR)

<https://www.archives.gov/federal-register/cfr/>

Title 14, CFR Part 157, *Notice of Construction, Alternation, Activation and Deactivation*

Title 29, CFR Part 1910, *Occupational Safety and Health Standards*

Title 40, CFR Part 112, *Oil Pollution Prevention*

Title 40, CFR Part 113, *Liability Limits for Small Onshore Storage Facilities, Subpart A, "Oil Storage Facilities"*

DEFENSE STANDARDIZATION PROGRAM OFFICE (DSPO)

<http://www.dsp.dla.mil>

MIL-STD-882, *System Safety Program Requirements*

MIL-STD-1472, *Human Engineering Design Criteria for Military Systems, Equipment and Facilities*

MIL-STD-3007, *Standard Practice for Unified Design Criteria and Unified Facilities Guide Specifications*

UNDERWRITERS LABORATORY (UL)

www.ul.com

UL 96A, *Installation of Lightning Protection Systems*

UL 779, *Electrically Conductive Floorings*

A-2 NON-GOVERNMENT PUBLICATIONS

NATIONAL FIRE PROTECTION ASSOCIATION (NFPA)

www.nfpa.org

NFPA 13, *Sprinkler Systems*

NFPA 70, *National Electric Code (NEC), latest edition*

NFPA 72, *National Fire Alarm Code, latest edition*

NFPA 75, *Standard for the Protection of Information Technology Equipment*

NFPA 101, *Life Safety Code, latest edition*

NFPA 720, *Standard for the Installation of Carbon Monoxide (CO) Detection and Warning Equipment*

NFPA 780, *Standard for the Installation of Lightning Protection Systems, latest edition*

AMERICAN STANDARDS FOR TESTING AND MATERIALS (ASTM)

www.astm.org

ASTM D 523, *Standard Test Method for Specular Gloss*

AMERICAN NATIONAL STANDARDS INSTITUTE (ANSI)

www.ansi.org

ASME/ANSI A17.1 & A17.3, *Safety Code for Elevators and Escalators*

ANSI A148.1, *Electrically Conductive Floorings*

ANSI C84.1, *Electric Power Systems and Equipment – Voltage Ratings (60 Hertz)*

ANSI/ESD S7.1, *Resistive Characterization of Materials – Floor Materials*

AMERICAN SOCIETY OF HEATING, REFRIGERATING, AND AIR CONDITIONING ENGINEERS (ASHRAE)

www.ashrae.org

ASHRAE 90.1, *Energy Standard for Buildings (except low-rise residential buildings)*

INTERNATIONAL CODE COUNCIL (ICC)

www.iccsafe.org

International Building Code (IBC)

APPENDIX B BEST PRACTICES

B-1 DEVELOPMENT OF REQUIRED BUILDING AREA AND LAYOUT.

During the planning/DD 1391 development process, the planner should contact appropriate local personnel to discuss and finalize specific space requirements. Confirm area requirements for electronic equipment areas with the requirements developer. In addition, there are unique mechanical/electrical requirements for ATCFs.

For the ATCT, the circulation factor is greater than normal due to limited building footprint.

B-2 ATCT HEIGHT DETERMINATION.

After site selection and issuance of siting report, the planner can determine the tower height and consequently, the number of floors in the ATCT.

B-3 USE OF DIMENSIONS ON FLOOR PLAN DIAGRAMS.

The use of floor plan diagrams is generally helpful to communicate the overall layout and adjacencies in each facility type.

B-4 PROJECT EXPERIENCE.

Require the use of experienced A/E, designers and builders.

B-5 AT/FP REQUIREMENTS.

Reduce the impact of AT/FP requirements.

B-6 TEMPORARY MOBILE ATCT.

During the planning/DD 1391 development phase, the need for a temporary mobile ATCT should be determined to avoid interruptions of continuous ATC operations.

B-7 ACCESSIBILITY VS. FUNCTIONALITY.

Improve accessibility without affecting functionality.

B-8 ELEVATOR MACHINE ROOM.

A room housing elevator machine equipment.

B-9 EXTERIOR CATWALK ACCESS.

The catwalk must be accessible directly from the Cab stair via an access door hatch. Using the Catwalk to provide secondary egress from the Cab is optional, not mandatory; the final decision on the requirement for secondary egress shall be determined by the local Authority Having Jurisdiction (AHJ).

B-10 CATWALK SCAFFOLD.

Consider a means to attach scaffolding to the catwalk for regular maintenance of the tower shaft. Reinforced holes may be designed into the catwalk on all four sides of the shaft to allow scaffolding cables to be routed through the holes and secured.

B-11 EXTERIOR OBSERVATION AREA GRATES.

There are corrosion concerns with the metal grates, especially ATCTs near the coast. The salt in the air helps speed up the corrosion process. Even if the grating is galvanized, some corrosion will still occur. Implement detailed solutions during the design and siting phase.

B-12 OVERALL TOWER SHAFT.

A rectangular tower shaft floor plan often provides an economical use of space. Electronic equipment racks, stairwells and elevators are rectangular in shape and fit more efficiently in a rectangular tower to reduce materials and cost.

B-13 ATCT POWER SHADES.

Recommend not using power shades in the tower Cab due to maintenance issues. If the electric motors fail, replacements may not be readily available and the shades remain broken.

B-14 CABLE TRAY LAYOUT/ROUTING.

Cable tray routing should be planned and designed to provide direct routing between equipment served. The preference is that cable tray routing should be confined within the operational spaces where possible, and avoid corridors especially in multi-occupancy buildings. Routing should minimize penetration of fire-rated walls and floors. Depending on facility configuration and required path between equipment, the cable trays may have to be routed through corridors.

B-15 ATCT CABLE LENGTH.

Minimizing the cable distance is of extreme importance and should not be sacrificed for other design considerations. An example would be offsetting the cable path to facilitate HVAC duct. Interdisciplinary coordination early in the design is very important in reducing cable length. Additionally, the cable chase is meant to be a straight vertical shaft with no horizontal jogs from one location to another. Coaxial cable connecting the radios to the antennas is very stiff and cannot easily be routed through offsets.

B-16 DESIGN SPECIAL LOADS.

The structural designer will provide for the support of communication, future ceiling track, and other special equipment.

Before undertaking unique antenna support designs, consider the use of existing commercial products suitable for the purpose.

B-17 LANDSCAPING AND BIRD ISSUES.

Contractor should be aware of bird issues when creating landscaping plan. For example, retention ponds tend to also attract birds, especially if there is water present all the time.

B-18 FOAM INSULATION.

Consider spray on foam in equipment and mechanical areas for sound attenuation that meets smoke development and flame spread criteria.

B-19 PARKING.

The ATC electronic equipment maintenance division typically has numerous Government vehicles used to travel on the airfield. If the facility is part of the airfield perimeter security fence, consider parking some of the Government vehicles used on the airfield on the airfield side.

B-20 WORK NOT INCLUDED IN CONSTRUCTION CONTRACT.

The following items, except as noted, are Government-Furnished Equipment (GFE) and will be installed by others during construction or upon completion of the construction contract.

1. Antennas. Antennas will be Government installed. All required safety features and lightning protection will be incorporated to protect property and personnel. Lightning protection is provided and installed by the Contractor, and must protect any antennas without integral lightning protection. The antenna mast must withstand wind loads based on the maximum gust conditions and take into consideration the projected heights of antennas to be mounted on the ATCT as well as being capable of resisting lateral loads required by the applicable safety codes. Also consider ice loads and wind-borne salt spray, and how it corrodes and affects radio inter-mod vulnerability.
2. Light Guns. Install eyebolts in the ceiling to hang light guns. These should be located adjacent to light gun outlets. If desired, the battery-operated desk mount type light gun may be installed in lieu of the ceiling mount type. The light gun(s) must be purchased with local Operations and Maintenance (O&M) funds. If battery-powered light guns are used, a 115 +/- 10 VAC outlet must be installed on the console within three feet of each proposed light gun location. Coordinate the location of the light guns with the user during the planning process. Consult with the local Air Operations Department to determine if any existing hard-wired light guns require relocation. If required, the Contractor is responsible for relocating any existing light guns.
3. CCTV Security System. The CCTV security system is Government furnished and installed (GFGI). The Contractor provides rough-in and conduits with pull wires as required.
4. Tower Radar Display Monitor. The Tower Radar Display monitor is GFGI.

5. ATC data or communications cabling internal to the facility, other than office telephone systems and local area network (LAN) cabling to desktop computers, is GFGI.
6. ATC Electronic Equipment Room communications racks, communications equipment, and radar/radar housing are GFGI. Wall-mounted data or telecommunications cabinets or related conduit are furnished and installed by the Contractor.
7. FAA Coordination. Coordinate relocation of existing equipment and connectivity with the FAA.
 - **Army:** ATC equipment: radios, STARS, communication and recording equipment, Voice Communications Switching System (VCSS), etc. is installed by separate contract and is procured through Product Manager Air Traffic Control (PM ATC) at the Army Aviation and Missile Command (AMCOM) Redstone Arsenal, AL. Requirements and Technical oversight is a function of USAISEC Fort Detrick, MD. The Contractor is responsible for providing conduit and pull strings for installation. Console cut-out locations and instrument locations must be determined during design. Items to be transferred over from existing facilities must be identified. Weather station equipment and locations must be coordinated with the organization responsible for weather status on the installation.
 - **Air Force:** ATC equipment: radios, STARS and RADAR consoles, communication and recording equipment, Enhanced Terminal Voice Switch (ETVS) etc. is installed by separate contract and is procured through UNK due to 38 EIG stepping away. Requirements and Technical oversight is a function of HQ AFFSA. The Contractor is responsible for providing conduit and pull strings for installation. Console cut-out locations and instrument locations must be determined during design. Items to be transferred over from existing facilities must be identified. Weather station equipment and locations must be coordinated with the organization responsible for weather status on the installation.

Refer to ETL 02-12, *Communications and Information System Criteria for Air Force Facilities*, which delineates programming responsibilities for Real Property versus equipment.

APPENDIX C OUTLINE OF TYPICAL SITE SELECTION PROCESS

The air traffic control tower site selection process is a collaborative effort amongst the planner, Air Ops/Customer, and the representative performing the site evaluation study.

C-1 Establish Tower Siting Study Representative/Methodology (Government/Consultant, etc.)

- See Site Selection and Approval Process in Chapter 2.

C-2 Establish authority for tower site approval.

- See Site Selection and Approval Process in Chapter 2.

C-3 Base/authority recommends potential site(s) for consideration.

- Planner coordinates tower siting study.
- Perform preliminary desktop study:
- Use GIS and other basic available tools to evaluate proposed sites

C-4 Establish site viability and basic geometry compliance.

- Safety zones/clearances
- Site angle to critical areas
- Obstruction avoidance
- Establish preliminary tower height
- Re-work proposed options and results from preliminary study with feedback/input from Air Ops and Planner. Revise and establish new viable options as required.

C-5 Basic considerations in site selection.

- Clear Zone conflicts (existing and future – consider impact of planned/future projects)
- Existing infrastructure
- Future development
- Environmental/Archaeological Issues
- Anti-Terrorism/Force Protection (AT/FP)
- Exact site variance – consider that exact placement of tower on proposed site may vary during actual design for various reasons. Evaluate envelope of reasonable exact locations at a specified site.
- Other special design considerations (Light vault locations, special seismic design, special foundation design, etc.)
- Terminal Approach Procedures (TERPS)

- Existing equipment relocation – consider if space is required for relocation of existing equipment

C-6 Narrow recommended viable site(s) based on considerations.

- Visual tower site evaluation and validation study: (use recommended or equivalent process below)
- Visually validate Tower cab vantage point Height Options
- Perform physical site survey
- Utilize vertical man-lift and accurate GPS on proposed site location/cab vantage point
- Film 360-degree video from tower cab vantage point
- Validate control points
- Consider/evaluate alternate vantage points/elevations

C-7 Re-Evaluate and Rank viable tower sites.

- Assess visual vantage point study results
- Consider optimal visual vantage point
- Consider operational requirements

C-8 Prepare Final Report (forward to planner).

- Summary of viable tower sites
- Plan to resolve visual obstructions
- Maps, flight paths, and other relevant data
- Pros/Cons for viable sites
- Recommended site selection

C-9 Final Site Selection.

- Conduct meeting with selecting authority
- Review final study/recommendations

C-10 Begin formal site approval process.

- See Site Selection and Approval Process in Chapter 2.

C-11 Prepare activity 1391 (use worst case height).

APPENDIX D GLOSSARY

ACRONYMS

A	Ampere(s)
AAAS	Army Airfield Automation System
ABAAS	Architectural Barriers Act Accessibility Standards
A-E	Architect - Engineer
AF	Air Force
AFCEC	Air Force Civil Engineer Center
AFFSA	Air Force Flight Standards Agency
AFI	Air Force Instruction
AFPD	Air Force Policy Directive
AFJMAN	Air Force Joint Manual (Inter-service)
AFMAN	Air Force Manual
AIA	American Institute of Architects
ALCP	Airfield Lighting Control Panel
ANSI	American National Standards Institute
AOF	Airfield Operations Flight
AOF/CC	Airfield Operations Flight Commander
ARAC	Army Radar Approach Control (same as RAPCON and RATCF)
ARNGB	Army National Guard Bureau
ASHRAE	American Society of Heating, Refrigerating and Air-Conditioning Engineers
ASME	American Society of Mechanical Engineers
ASR	Available Supply Rate OR Airport Surveillance Radar
ASTM	American Society for Testing and Materials
ATC	Air Traffic Control
ATCF	Air Traffic Control Facility

ATCT	Air Traffic Control Tower/ Airport Traffic Control Tower
AT/FP	Antiterrorism Force Protection
ATSCOM	Air Traffic Services Command
BEAP	Base Exterior Architecture Plans
BIA	Bilateral Infrastructure Agreement
BTU / H	British Thermal Unit per Hour
CATV	Cable Television
CBI	Computer-Based Instruction
CC	Commander
CCB	Construction Criteria Base
CCTLR	Chief Controller
CCTV	Closed Circuit Television
CFCI	Contractor Furnished, Contractor Installed
CFM	Cubic Feet per Minute
CFR	Code of Federal Regulations
CONUS	Contiguous United States
CM	Centimeter(s)
CMU	Concrete Masonry Unit
CPDS	Critical Power Distribution System
dB	Decibel
DB	Design-Build
DBT	Design Basis Threat
DoD	Department of Defense
DOT	Department of Transportation
DSS	Data Systems Specialist

E&I	Engineering and Installation
ECS	Emergency Communications System
EES	Earth Electrode System
E/G	Engine Generator
EMCS	Energy Management and Control System
EMR	Electromagnetic Radiation
EPA	Environmental Protection Agency
EPO	Emergency Power - Off
ESD	Electrostatic Dissipative OR Electrostatic Discharge
ESS	Electronic Security Systems
ETL	Engineering Technical Letter
ETVS	Enhanced Terminal Voice Switch
F	Fahrenheit
FAA	Federal Aviation Administration
FAA-STD	Federal Aviation Administration Standard
FIPS	Federal Information Processing Standards
FRD	Facility Requirements Documents
FRS	Facility Requirements Supplements
GCA	Ground Controlled Approach
GEMD	Ground Electronics Maintenance Division
GFE	Government Furnished Equipment
GFGI	Government Furnished, Government Installed
GFI	Ground Fault Interrupt OR Ground Fault Indicator
GPS	Global Positioning System
GSF	Gross Square Feet

GWB	Gypsum Wall Board
HERF	Hazards Of Electromagnetic Radiation To Fuel
HERO	Hazards Of Electromagnetic Radiation To Ordnance
HERP	Hazards Of Electromagnetic Radiation To Personnel
HNFA	Host Nation Funded Construction Agreements
HPS	High Pressure Sodium
HQUSACE	Headquarters, U.S. Army Corps of Engineers
HVAC	Heating, Ventilating and Air Conditioning
Hz	Hertz
IDF	Intermediate Distribution Frame
IDS	Intrusion Detection System
IDSEP	Intrusion Detection System Engineering Plan
IFR	Instrument Flight Rules
LAN	Local Area Network
LB	Pound(s)
LPS	Liters Per Second
Lx	Lux
M	Meter(s)
MAJCOM	Major Command
MDF	Main Distribution Frame
MIL-HDBK	Military Handbook
MILCON	Military Construction Program
MIL STD	Military Standard
MM	Millimeter(s)
NAS	Naval Air Station or National Airspace System

NAS Mod	National Airspace System Modernization
NATOPS	Naval Air Training and Operating Procedures Standardization
NAVAIDS	Navigational Aids System
NAVAIR	Naval Air Systems Command
NAVFAC	Naval Facilities Engineering Command
NAVFACINST	Naval Facilities Instruction
NAVSEA	Naval Sea Systems Command
NCOIC	Non-Commissioned Officer in Charge
NEC	National Electric Code
NEMA	National Electrical Manufacturers Association
NFPA	National Fire Protection Association
NSF	Net Square Feet
O&M	Operations and Maintenance
OP / OPS	Operations
OPNAVINST	Chief of Naval Operations Instruction
OSHA	Occupational Health and Safety Administration
PALS	Precision Approach Landing System
PAR	Precision Approach Radar
PM ATC	Product Manager Air Traffic Control
PSF	Pounds (lbs) per Square Foot
R&M	Reliability and Maintainability
RADHAZ	Radiation Hazard
RAF	Raised Access Flooring
RAPCON	Radar Approach Control (same as ARAC or RATCF)
RATCF	Radar Air Traffic Control Facility (same as ARAC or RAPCON)

RF	Radio Frequency
RFI	Radio Frequency Interference
RFP	Request For Proposal
SF	Square Foot / Feet
SIE	Systems Integration Engineer
SOFA	Status of Forces Agreements
SOI	Statement of Intent
SPAWAR	Space and Naval Warfare Systems Command
STARS	Standard Terminal Automation Replacement System
TACAN	Tactical Air Navigation
TERP / TERPS	Terminal Instrument Procedures OR Terminal Procedures
TI	Technical Instruction
TM	Technical Manual
TRACON	Terminal Radar Approach Control
TTB	Telephone Terminal Backboard
TVSS	Transient Voltage Surge Suppressor
UFC	Unified Facility Criteria
UL	Underwriters Laboratory
UPS	Uninterrupted / Uninterruptible Power Supply
US	United States
USAASA	US Army Aeronautical Services Agency
USACE	US Army Corps of Engineers
USAF	United States Air Force
VAC	Volt(s), Alternating Current
VCSS	Voice Communication Switching System

VFR Visual Flight Rules

W Watt(s)

WBDG Whole Building Design Guide (www.wbdg.org)