

UNIFIED FACILITIES CRITERIA (UFC)

STRUCTURAL ENGINEERING



APPROVED FOR PUBLIC RELEASE; DISTRIBUTION UNLIMITED

UNIFIED FACILITIES CRITERIA (UFC)

STRUCTURAL ENGINEERING

Any copyrighted material included in this UFC is identified at its point of use. Use of the copyrighted material apart from this UFC must have the permission of the copyright holder.

U.S. ARMY CORPS OF ENGINEERS

NAVAL FACILITIES ENGINEERING SYSTEMS COMMAND (Preparing Activity)

AIR FORCE CIVIL ENGINEER CENTER

Record of Changes (changes are indicated by \1\ ... /1/)

Change No.	Date	Location
01	04 Feb. 2022	\1\ -2-4.1 Delegated Engineered Systems clarification -Table 2-2 Tsunami Risk Category and Sea Level Rise Scenario added to Table 2-2 -Table 2-2 Footnotes added to Table 2-2 -2-7.2 New section on 3D printed concrete added -3-3 Addition to Chapter 6 Tsunami Loads -8-1.1 IEBC clarification respecting Tsunami Loads and Effects -C-14.1 Clarification respecting Probabilistic Tsunami Hazard Analysis. /1/

This UFC supersedes UFC 3-301-01, dated 1 June 2013 with Change 4 of 12 September 2016.

FOREWORD

The Unified Facilities Criteria (UFC) system is prescribed by MIL-STD 3007, including the exemption process, and provides planning, design, construction, sustainment, restoration, and modernization criteria, and applies to the Military Departments, the Defense Agencies, and the DoD Field Activities in accordance with [USD \(AT&L\) Memorandum](#) dated 29 May 2002. UFC will be used for all DoD projects and work for other customers where appropriate. All construction outside of the United States is also governed by Status of Forces Agreements (SOFA), Host Nation Funded Construction Agreements (HNFA), and in some instances, Bilateral Infrastructure Agreements (BIA.) Therefore, the acquisition team must ensure compliance with the most stringent of the UFC, the SOFA, the HNFA, and the BIA, as applicable.

UFC are living documents and will be periodically reviewed, updated, and made available to users as part of the Services' responsibility for providing technical criteria for military construction. Headquarters, U.S. Army Corps of Engineers (HQUSACE), Naval Facilities Engineering Systems Command (NAVFAC), and Air Force Civil Engineer Center (AFCEC) are responsible for administration of the UFC system. Military Departments, the Defense Agencies, and the DoD Field Activities should contact the preparing service for document interpretation and improvements. Technical content of this UFC is the responsibility of the DoD structural working group. Recommended changes with supporting rationale should be sent to the respective service proponent office by the following electronic form: [Criteria Change Request](#). The form is also accessible from the Internet sites listed below.

UFC are effective upon issuance and are distributed only in electronic media from the following source:

- Whole Building Design Guide web site <http://dod.wbdg.org/>.

Refer to UFC 1-200-01, *DoD Building Code (General Building Requirements)*, for implementation of new issuances on projects.

AUTHORIZED BY:

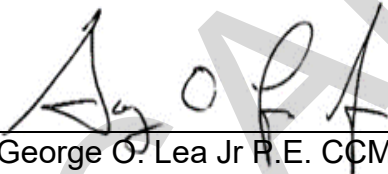

George O. Lea Jr R.E. CCM FCMAA
Chief Military Engineering Branch
Engineering and Construction Division
US Army Corps of Engineers



ROBERT D. CURFMAN, P.E.
Chief Engineer
Naval Facilities Engineering Command



NANCY J. BALKUS, P.E., SES
Deputy Director of Civil Engineers
DCS Logistics, Engineering &
Force Protection (HAF/A4C)
HQ, United States Air Force



MICHAEL McANDREW
Deputy Assistant Secretary of Defense
(Facilities Management)
Office of the Assistant Secretary of Defense
(Sustainment)

**UNIFIED FACILITIES CRITERIA (UFC)
REVISION SUMMARY SHEET**

Subject: UFC 3-301-01, *Structural Engineering*

Cancels: UFC 3-301-01, *Structural Engineering* dated 1 June 2013 with Change 3 of 12 September 2016

Description of Changes:

- This UFC combines UFC 3-301-01, *Structural Engineering*, and all provisions of UFC 3-310-04, *Seismic Design for Buildings*, that do not relate to Risk Category V structures, strategic military assets. UFC 3-301-02 now applies strictly to Risk Category V structures only.
- This UFC adopts the structural design provisions of the 2018 *International Building Code* (2018 IBC) for use in DoD building design and renovation.
- This UFC adopts the structural design provisions of the 2018 International Existing Building Code (2018 IEBC).
- Additional design load combinations are now specified for the design of structural members sensitive to vertical earthquake ground motion.
- Live loads are updated to coordinate with 2018 IBC.
- This UFC adopts the structural design provisions of the 2016 Minimum Design Loads for Buildings and Other Structures (ASCE 7-16).
- Site-specific structural load data tables for wind are updated to the basic wind speed values from the 2018 IBC and ASCE/SEI 7-16.
- Site-specific structural load data tables for seismic ground motion parameters are updated to the risk-targeted maximum considered earthquake values and the peak ground accelerations from ASCE/SEI 7-16.
- Updated snow, wind and seismic load tables are no longer part of this UFC; they can be found using the structural load data tool hosted on the Whole Building Design Guide website at:
<https://www.wbdg.org/additional-resources/tools/ufcsldt>

Reasons for Changes:

- The updated UFC is designed to be consistent with and to supplement the guidance contained in the 2018 IBC as modified and implemented by UFC 1-200-01.

Impact:

The newly introduced design load combinations for structural members sensitive to vertical ground motions may result in modest increases in the cost of those members. However, the seismic performance of these members should improve.

The following additional benefit should be realized:

- Web based load calculating tool ensures that the locations identified and the loadings described are complete and current with the most up-to-date available information.
- DoD structural design criteria is current with industry codes and standards.

Non-Unified Items: This document contains no non-unified items.

CANCELLED

TABLE OF CONTENTS

CHAPTER 1 INTRODUCTION	1
1-1 PURPOSE AND SCOPE	1
1-2 BACKGROUND	1
1-3 APPLICABILITY	2
1-4 CONFLICTS AND MODIFICATIONS	2
1-5 OVERVIEW OF THIS UFC	2
1-6 COMMENTARY	4
1-7 OTHER CRITERIA	4
1-7.1 General Building Requirements.....	4
1-7.2 Progressive Collapse Analysis and Design.....	4
1-7.3 Design of Risk Category V Structures.....	4
CHAPTER 2 MODIFICATIONS TO IBC	7
2-1 IBC CHAPTER 1 - SCOPE AND ADMINISTRATION	7
2-1.1 Section 101 – GENERAL.....	7
2-2 IBC CHAPTER 2 – DEFINITIONS	7
2-2.1 Section 202 – DEFINITIONS.....	7
2-3 IBC CHAPTER 4 – SPECIAL DETAILED REQUIREMENTS BASED ON OCCUPANCY AND USE	8
2-3.1 Section 423 – STORM SHELTERS.....	8
2-4 IBC CHAPTER 16 - STRUCTURAL DESIGN	8
2-4.1 Section 1603 - CONSTRUCTION DOCUMENTS.....	8
2-4.2 Section 1604 - GENERAL DESIGN REQUIREMENTS.....	10
2-4.3 Section 1605 – LOAD COMBINATIONS.....	15
2-4.4 Section 1607 - LIVE LOADS.....	19
2-4.5 Section 1608 - SNOW LOADS.....	20
2-4.6 Section 1609 - WIND LOADS.....	20
2-4.7 Section 1613 - EARTHQUAKE LOADS.....	22
2-4.8 Section 1615 – TSUNAMI LOADS.....	24
2-5 IBC CHAPTER 17 - SPECIAL INSPECTIONS AND TESTS	24
2-5.1 Section 1701 – GENERAL.....	24
2-5.2 Section 1703 – APPROVALS.....	25

2-5.3	Section 1704 – SPECIAL INSPECTIONS AND TESTS, CONTRACTOR RESPONSIBILITY AND STRUCTURAL OBSERVATIONS.....	26
2-5.4	Section 1705 – REQUIRED SPECIAL INSPECTIONS AND TESTS...	27
2-6	IBC CHAPTER 18 - SOILS AND FOUNDATIONS.	28
2-6.1	Section 1808 – FOUNDATIONS.....	28
2-6.2	Section 1809 - SHALLOW FOUNDATIONS.	28
2-7	IBC CHAPTER 19 – CONCRETE.	29
2-7.1	Section 1901 – GENERAL.....	29
2-7.2	Section 1904 - DURABILITY REQUIREMENTS.....	34
1904.3	- Environmental Severity Classification and Concrete Cover [Addition].....	34
2-7.3	Section 1907 - MINIMUM SLAB PROVISIONS.	34
2-8	IBC CHAPTER 21 – MASONRY.	39
2-8.1	Section 2101 – GENERAL.....	39
2-8.2	Section 2104 – CONSTRUCTION.....	39
2-8.3	Section 2106 - SEISMIC DESIGN.	40
2-8.4	Section 2109 - EMPIRICAL DESIGN OF MASONRY [Deletion].....	42
2-9	IBC CHAPTER 22 – STEEL.....	42
2-9.1	Section 2204 – CONNECTIONS.	42
2-9.2	Section 2205 - STRUCTURAL STEEL.	42
2-9.3	Section 2210 - COLD-FORMED STEEL.....	42
2-9.4	Section 2211 - COLD-FORMED STEEL LIGHT-FRAMED CONSTRUCTION.....	42
2-10	IBC CHAPTER 23 – WOOD.....	44
2-10.1	Section 2308 - CONVENTIONAL LIGHT-FRAME CONSTRUCTION.	44
CHAPTER 3 MODIFICATIONS TO ASCE 7		45
3-1	ASCE 7-16 CHAPTER 1 – GENERAL.....	45
3-1.1	Section 1.3 - BASIC REQUIREMENTS.	45
3-2	ASCE 7-16 CHAPTER 2 – COMBINATIONS OF LOADS.....	45
3-2.1	Section 2.3 - LOAD COMBINATIONS FOR STRENGTH DESIGN. ...	45
3-2.2	Section 2.4 – LOAD COMBINATIONS FOR ALLOWABLE STRESS DESIGN.....	46
3-2.3	Section 2.5 - LOAD COMBINATIONS FOR EXTRAORDINARY EVENTS.	46

3-3	ASCE 7-16 CHAPTER 7 – SNOW LOADS.....	46
3-3.1	Section 7.4 – Sloped Roof Snow Loads, p_s [Supplement].	47
3-4	ASCE 7-16 CHAPTER 11 – SEISMIC DESIGN CRITERIA.	47
3-4.1	Section 11.1 – GENERAL.....	47
3-4.2	Section 11.2 – DEFINITIONS.	48
3-4.3	Section 11.5 - IMPORTANCE FACTOR AND RISK CATEGORY.	48
3-5	ASCE 7-16 CHAPTER 12 – SEISMIC DESIGN REQUIREMENTS FOR BUILDING STRUCTURES.....	48
3-5.1	Section 12.2 – STRUCTURAL SYSTEM SELECTION.....	48
3-5.2	Section 12.6 - ANALYSIS PROCEDURE SELECTION [Supplement].	49
3-5.3	Section 12.8 - EQUIVALENT LATERAL FORCE PROCEDURE [Supplement].....	49
3-5.4	Section 12.10 - DIAPHRAGMS, CHORDS, AND COLLECTORS.	59
3-5.5	Section 12.11 - STRUCTURAL WALLS AND THEIR ANCHORAGE. .	59
3-6	ASCE 7-16 CHAPTER 13 – SEISMIC DESIGN REQUIREMENTS FOR NONSTRUCTURAL COMPONENTS.	60
3-6.1	Section 13.1 – GENERAL.....	60
3-6.2	Section 13.2 - GENERAL DESIGN REQUIREMENTS.	60
3-6.3	Section 13.3 - SEISMIC DEMANDS ON NONSTRUCTURAL COMPONENTS.	62
3-6.4	Section 13.4 - NONSTRUCTURAL COMPONENT ANCHORAGE.	62
3-6.5	Section 13.5 - ARCHITECTURAL COMPONENTS.	63
3-6.6	Section 13.6 - MECHANICAL AND ELECTRICAL COMPONENTS.	64
3-7	ASCE 7 CHAPTER 15 – SEISMIC DESIGN REQUIREMENTS FOR NONBUILDING STRUCTURES.....	66
3-7.1	Section 15.4 - STRUCTURAL DESIGN REQUIREMENTS.	66
3-7.2	Section 15.5 - NONBUILDING STRUCTURES SIMILAR TO BUILDINGS.	67
3-7.3	Section 15.7 - TANKS AND VESSELS.....	67
3-8	ASCE 7 CHAPTER 26 – WIND LOADS: GENERAL REQUIREMENTS	68
3-8.1	Section 26.12 ENCLOSURE CLASSIFICATION	68
CHAPTER 4 SEISMIC EVALUATION AND RETROFIT OF EXISTING BUILDINGS ..		69
4-1	GENERAL	69
4-2	MODIFICATIONS TO RP 8	70

4-2.1	Performance Objectives for Evaluation and Retrofit using ASCE 41-13	70
4-2.2	Exemptions and Benchmark Buildings	72
4-3	MODIFICATIONS TO 2018 IEBC CHAPTER 5	73
4-3.1	Section 502 - ADDITIONS	73
4-3.2	Section 503 - ALTERATIONS	74
4-3.3	Section 506 - CHANGE OF OCCUPANCY	74
4-3.4	Section 507 - HISTORIC BUILDINGS	74
4-3.5	Section 508 - MOVED STRUCTURES [ADDITION]	75
CHAPTER 5	NONBUILDING STRUCTURES	83
5-1	HIGHWAY BRIDGE DESIGN	83
5-2	RAILROAD BRIDGE DESIGN	83
5-3	TANKS FOR LIQUID STORAGE	83
5-4	TANKS FOR PETROLEUM STORAGE	83
5-5	ENVIRONMENTAL ENGINEERING CONCRETE STRUCTURES	83
5-6	PRESTRESSED CONCRETE TANKS	83
5-7	WATER TREATMENT FACILITIES	83
5-8	TRANSMISSION TOWERS AND POLES	83
5-9	ANTENNA TOWERS	84
5-10	PEDESTRIAN BRIDGES	84
CHAPTER 6	MODIFICATIONS TO THE IBC FOR CRITICAL HEALTHCARE FACILITIES	85
6-1	IBC CHAPTER 1 – SCOPE AND ADMINISTRATION	85
6-1.1	Section 101 - GENERAL	85
6-2	IBC CHAPTER 16 – STRUCTURAL DESIGN	85
6-2.1	Section 1603 - CONSTRUCTION DOCUMENTS	85
6-3	IBC CHAPTER 18 - SOILS AND FOUNDATIONS	85
6-3.1	Section 1807 – FOUNDATION WALLS, RETAINING WALLS AND EMBEDDED POSTS AND POLES	85
6-4	IBC CHAPTER 19 - CONCRETE	86
6-4.1	Section 1901 – GENERAL	86
6-4.2	Section 1903 – SPECIFICATIONS FOR TESTS AND MATERIALS ..	86
6-4.3	Section 1905 – MODIFICATIONS TO ACI 318	86

6-4.4	Section 1908 - SHOTCRETE.....	87
6-5	IBC CHAPTER 21 - MASONRY	87
6-5.1	Section 2101 - GENERAL.....	87
6-5.2	Section 2106 - SEISMIC DESIGN	87
6-5.3	Section 2107 - ALLOWABLE STRESS DESIGN	88
6-6	IBC CHAPTER 22 - STEEL.....	89
6-6.1	Section 2210 - COLD-FORMED STEEL.....	89
6-6.2	Section 2211 - COLD-FORMED STEEL LIGHT-FRAMED CONSTRUCTION.....	89
CHAPTER 7 MODIFICATIONS TO ASCE 7-16 FOR CRITICAL HEALTHCARE FACILITIES.....		91
7-1	ASCE 7-16 CHAPTER 11 – SEISMIC DESIGN CRITERIA	91
7-1.1	Section 11.1 – GENERAL.....	91
7-2	ASCE 7-16 CHAPTER 12 – SEISMIC DESIGN REQUIREMENTS FOR BUILDING STRUCTURES.....	91
7-2.1	Section 12.1 – STRUCTURAL DESIGN BASIS.....	91
7-2.2	Section 12.2 – STRUCTURAL SYSTEM SELECTION.....	92
7-2.3	Section 12.3 - DIAPHRAGM FLEXIBILITY, CONFIGURATION IRREGU LARITIES, AND REDUNDANCY	96
7-2.4	Section 12.12 - DRIFT AND DEFORMATION	96
7-2.5	ASCE 7-16 CHAPTER 13 – SEISMIC DESIGN REQUIREMENTS FOR NONSTRUCTURAL COMPONENTS	96
7-2.6	Section 13.2 - GENERAL DESIGN REQUIREMENTS	96
7-2.7	Section 13.4 - NONSTRUCTURAL COMPONENT ANCHORAGE	97
7-2.8	Section 13.5 - ARCHITECTURAL COMPONENTS	97
7-2.9	Section 13.6 - MECHANICAL AND ELECTRICAL COMPONENTS	97
CHAPTER 8 MODIFICATIONS TO IBC.....		99
8-1	IEBC CHAPTER 5 - PRESCRIPTIVE COMPLIANCE METHOD	99
8-1.1	Section 501 – General	99
8-2	IEBC CHAPTER 7 – ALTERATIONS - LEVEL ONE	100
8-2.1	SECTION 703 - GENERAL.....	100
APPENDIX A REFERENCES.....		101
APPENDIX B BEST PRACTICES		115
B-1	STRUCTURAL DESIGN.....	115

B-1.1	Building Drift Limits.....	115
B-1.2	Impact Resistant Glazing.....	115
B-1.3	Hard Wall Buildings.....	116
B-1.4	Wind and Seismic Loads on Photovoltaic Arrays.....	116
B-1.5	Wind Loads on Buildings with Large Openings.....	116
B-2	SOILS AND FOUNDATIONS.....	116
B-2.1	Gable Bent Footings.....	116
B-2.2	Footings on Expansive Soils.....	117
B-2.3	Footing Depth Due to Frost.....	117
B-3	CONCRETE.....	118
B-3.1	Slab-on-Ground Concrete Strength.....	118
B-3.2	Slab-on-Ground Joints.....	118
B-3.3	Slab-on-Ground Drying Shrinkage.....	118
B-3.4	Slab-on-Ground Vapor Retarder/Barrier.....	119
B-3.5	Post-Installed Adhesive Concrete Anchors.....	120
B-4	MASONRY.....	120
B-4.1	Masonry Veneer Base Detail.....	120
B-5	STEEL.....	120
B-5.1	Shelf Angles for Masonry.....	120
B-5.2	Cold-Formed Continuous Beams and Joists.....	120
B-5.3	Masonry Veneer/Steel Stud Wall Detailing.....	120
B-5.4	Steel Structures in Corrosive Environments.....	121
B-5.5	Steel Structures in Arctic and Antarctic Zones.....	121
B-5.6	Steel Column Base Plate Shear Transfer.....	122
B-5.7	Steel Joist Connections.....	122
B-6	WOOD.....	122
B-6.1	Connections.....	122
APPENDIX C ALTERNATE DESIGN PROCEDURE FOR RC IV STRUCTURES.....		123
C-1	GENERAL.....	123
C-1.1	Overview.....	123
C-1.2	Design Review Panel.....	124
C-2	DEFINITIONS.....	124

C-2.1	General.....	124
C-3	CONSTRUCTION DOCUMENTS.....	124
C-3.1	General.....	125
C-4	GENERAL DESIGN REQUIREMENTS.....	125
C-4.1	General.....	125
C-5	LOAD COMBINATIONS.....	125
C-5.1	General.....	125
C-5.2	Seismic Load Combinations.....	125
C-6	DEAD LOADS.....	126
C-6.1	General.....	126
C-7	LIVE LOADS.....	126
C-7.1	General.....	126
C-8	SNOW LOADS.....	126
C-8.1	General.....	126
C-9	WIND LOADS.....	126
C-9.1	General.....	126
C-10	SOIL LATERAL LOADS.....	126
C-10.1	General.....	126
C-11	RAIN LOADS.....	126
C-11.1	General.....	126
C-12	FLOOD LOADS.....	127
C-12.1	General.....	127
C-13	ICE LOADS—ATMOSPHERIC ICING.....	127
C-13.1	General.....	127
C-14	TSUNAMI LOADS.....	127
C-14.1	General.....	127
C-15	EARTHQUAKE LOADS – GENERAL.....	127
C-15.1	Scope.....	127
C-16	EARTHQUAKE LOADS – SITE GROUND MOTION.....	127
C-16.1	General Procedure for Determining Design Spectral Response Accelerations.....	127
C-16.2	Site-specific Response Analysis for Determining Ground Motion Accelerations.....	128

C-16.3	Ground Motion Hazard Analysis.	128
C-17	EARTHQUAKE LOADS – CRITERIA SECTION.	128
C-17.1	Structural Design Criteria.....	128
C-17.2	Importance Factors.....	128
C-17.3	Site Limitations.	128
C-17.4	Building Configuration.....	129
C-17.5	Analysis Procedures.	129
C-18	EARTHQUAKE LOADS – MINIMUM DESIGN LATERAL FORCE AND RELATED EFFECTS.	131
C-18.1	Seismic Load Effect, <i>E</i>	131
C-18.2	Redundancy.....	131
C-18.3	Deflection and Drift Limits.....	131
C-18.4	Seismic Force-resisting Systems.....	132
C-19	DYNAMIC ANALYSIS PROCEDURES FOR THE SEISMIC DESIGN OF BUILDINGS.....	134
C-19.1	General.....	134
C-20	EARTHQUAKE LOADS, SOIL-STRUCTURE INTERACTION EFFECTS.	134
C-20.1	Analysis Procedure.....	134
C-21	SEISMIC DESIGN, DETAILING, AND STRUCTURAL COMPONENT LOAD EFFECTS.....	134
C-21.1	Structural Component Design and Detailing.....	134
C-21.2	Structural Integrity.....	134
C-21.3	Soils and Foundations.	134
C-22	SEISMIC DESIGN REQUIREMENTS FOR NONSTRUCTURAL COMPONENTS.....	134
C-22.1	Component Design.....	134
C-22.2	Performance Objectives.....	134
C-22.3	Modification of ASCE 7-16 for Life Safety Design.....	135
C-22.4	Modification of ASCE 7-16 for Immediate Occupancy Design.....	136
APPENDIX D GUIDANCE FOR SEISMIC DESIGN OF NONSTRUCTURAL COMPONENTS		140
D-1	INTRODUCTION.	141
D-1.1	Design Criteria.	141

D-1.2	Walk-down Inspections and Seismic Mitigation for Buildings in Risk Categories IV.....	141
D-2	ARCHITECTURAL COMPONENTS.....	142
D-2.1	Reference.....	142
D-2.2	General.....	142
D-2.3	Typical Architectural Components.....	142
D-3	MECHANICAL AND ELECTRICAL COMPONENTS.....	145
D-3.1	Component Support.....	145
D-3.2	Stacks (Exhaust) Associated with Buildings.....	156
D-3.3	Elevators.....	157
D-3.4	Lighting Fixtures in Buildings.....	161
D-3.5	Bridges, Cranes, and Monorails.....	161
APPENDIX E MECHANICAL AND ELECTRICAL COMPONENT CERTIFICATION		163
E-1	COMPONENT CERTIFICATION.....	163
E-1.1	General.....	163
APPENDIX F ABBREVIATIONS		167
APPENDIX G MINIMUM UNIFORMLY DISTRIBUTED LIVE LOADS, L_o, AND MINIMUM CONCENTRATED LIVE LOADS.....		173
G-1	REFERENCES.....	173

FIGURES

Figure 2-1	Widths of Thickened Slabs and Slab Edge Conditions Under Wall Loads.....	38
Figure 3-1	Anchorage of Walls to Flexible Diaphragm.....	60
Figure B-1	Design Depth of Bottom of Building Foundation.....	119
Figure D-1	Partial Infill Masonry Wall between Two Concrete Columns, Causing Adverse “Short Column” Effect.....	144
Figure D-2	Typical Details for Isolation of Rigid Partition Walls.....	146
Figure D-3	Typical Seismic Restraints for Floor-mounted Equipment.....	148
Figure D-4	Typical Seismic Restraints for Suspended Equipment.....	149
Figure D-5	Acceptable Seismic Details for Pipe Sway Bracing.....	151
Figure D-6	Pinned-pinned Support Condition for Table D-1.....	153
Figure D-7	Fixed-pinned Support Condition for Table D-2.....	154
Figure D-8	Fixed-fixed Support Condition for Table D-3.....	155
Figure D-9	Period Coefficients for Uniform Beams.....	158
Figure D-10	Single Guyed Stacks.....	159
Figure D-11	Elevator Details.....	160

TABLES

Table 2-1	Lateral Deflection Limits for Framing Supporting Exterior Wall Finishes	10
Table 2-2	Risk Category of Buildings and Other Structures	12
Table 2-3	Maximum Allowable Wall Load at a Thickened Slab for Wall Load Near Center of Slab or Near Keyed or Doweled joints.....	35
Table 2-4	Maximum Allowable Wall Load at a Thickened Slab for Wall Load Near Free Edge	36
Table 3-1	Replacement for ASCE 7-16 Table 12.2-1 Design Coefficients and Factors for Basic Seismic Force-Resisting Systems	50
Table 4-1	Replacement for ASCE 41-13 Table 4-6, Benchmark Buildings	76
Table 6-1	Minimum Thickness of Masonry Walls	90
Table 7-1	Replacement for ASCE 7-16 Table 12.2-1 Design Coefficients and Factors for Basic Seismic Force-Resisting Systems	93
Table C-1	System Limitations for Risk Category IV Buildings Designed Using Alternate Procedure of Chapter 3.....	137
Table D-1	Maximum Span for Rigid Pipe with Pinned-Pinned Conditions, L..	153
Table D-2	Maximum Span for Rigid Pipe with Fixed-Pinned Condition, L	154
Table D-3	Maximum Span for Rigid Pipe with Fixed-Fixed Condition, L.....	155
Table G-1	Minimum Uniformly Distributed Live Loads and Minimum Concentrated Live Loads⁹.....	173

This page intentionally left blank

CANCELLED

CHAPTER 1 INTRODUCTION

1-1 PURPOSE AND SCOPE.

This Unified Facility Criteria (UFC) provides requirements for structures designed and constructed for the Department of Defense (DoD). These technical requirements are based on the 2018 *International Building Code* (2018 IBC), as modified by UFC 1-200-01, *DoD Building Code (General Building Requirements)*, and the structural standard referenced by the 2018 IBC: ASCE/SEI 7-16 *Minimum Design Loads and Associated Criteria for Buildings and Other Structures* (hereinafter referred to simply as ASCE 7-16). The criteria further provides limited technical guidance for seismic evaluation and strengthening of existing buildings, and references the 2018 edition of the *International Existing Building Code* (2018 IEBC), ICSSC RP 8 / NIST GCR 11-917-12, *Standards of Seismic Safety for Existing Federally Owned and Leased Buildings* (RP 8) as well as ASCE/SEI 41-17, *Seismic Evaluation and Retrofit of Existing Buildings* (hereinafter referred to simply as ASCE 41-13). This information is for use by structural engineers to develop design calculations, specifications, plans, and design-build Requests for Proposal (RFPs), and it is meant to serve as the minimum design requirement for DoD buildings.

1-2 BACKGROUND.

UFC 1-200-01 implements and supplements 2018 IBC as the building code for DoD. Chapter 2 of this UFC further modifies the IBC for structural-specific design requirements and is organized by the chapter of the IBC that each section modifies. Apply any section in the 2018 IBC, that is not specifically referenced, as it is written in the 2018 IBC. Chapter 3 of this UFC further modifies ASCE 7-16 for structural-specific design requirements and is organized by the chapter of ASCE 7 that each section modifies. Apply any section in ASCE 7-16, that is referenced by the 2018 IBC but is not modified in Chapter 3 of this UFC, as it is written in ASCE 7-16.

The 2018 IBC and ASCE 7-16 section modifications are one of four actions, according to the following legend:

[Addition] – Add new section, including new section number, not shown in 2018 IBC or ASCE 7-16.

[Deletion] – Delete referenced 2018 IBC or ASCE 7-16 section or noted portion of a section.

[Replacement] – Delete referenced 2018 IBC or ASCE 7-16 section or noted portion and replace it with the narrative shown.

[Supplement] – Add narrative shown as a supplement to the narrative shown in the referenced section of 2018 IBC or ASCE 7-16.

The climatic and seismic data referenced in this UFC are intended as tools to assist in the consistent interpretation of the corresponding data in the IBC at significant DoD installations within the United States, and as the basis for applying the provisions of UFC 1-200-01 to significant DoD installations outside of the United States.

1-3 APPLICABILITY.

This UFC applies to all service elements and contractors involved in the planning, design and construction of DoD facilities worldwide.

1-4 CONFLICTS AND MODIFICATIONS.

The 2018 IBC provisions are directed toward public health, safety, and general welfare, presenting minimum standards that must be met by the private sector construction industry. The use of industry standards for DoD projects promotes communication in the marketplace, improves competition, and results in cost savings. However, the military sometimes requires higher standards to achieve unique building performance, or to construct types of facilities that are not used in the private sector. In addition, the construction of military facilities outside the United States can introduce requirements that are not addressed in national model building codes. Modifications to the 2018 IBC and ASCE 7-16 provisions contained herein are intended to fulfill those unique military requirements. Where conflicts between the 2018 IBC or ASCE 7-16 and this UFC arise, this UFC prevails.

In addition, for construction outside the United States, conflicts between host nation building codes and the UFC may arise. In those instances, the more stringent design provisions prevail.

1-5 OVERVIEW OF THIS UFC.

Brief descriptions of the various chapters and appendices of this UFC follow.

- Chapter 2 – MODIFICATIONS TO IBC. Chapter 2 provides supplemental requirements for applying the 2018 IBC structural provisions to conventional DoD building design by listing required modifications for specific 2018 IBC sections. The 2018 IBC sections that are not referenced in Chapter 2 or otherwise modified by provisions of Appendix C apply as they are written in the 2018 IBC.
- Chapter 3 – MODIFICATIONS TO ASCE 7. Chapter 3 provides supplemental requirements for applying the ASCE 7-16 structural provisions to conventional DoD building design by listing required modifications for specific ASCE 7-16 sections. The ASCE 7-16 sections that are adopted by the 2018 IBC but are not referenced in Chapter 3 or otherwise modified by provisions of Appendix C apply as they are written in ASCE 7-16.
- CHAPTER 4 - SEISMIC EVALUATION AND RETROFIT OF EXISTING BUILDINGS. This chapter contains provisions for the *repair, alteration*, change of occu-

pancy, acquisition, *addition* to and relocation of existing buildings. For this purpose, this chapter adopts by reference the provisions of ICSSC RP 8 / NIST GCR 11-917-12, *Standards of Seismic Safety for Existing Federally Owned and Leased Buildings*, cited herein as RP 8 as well as those of ASCE/SEI 41-13, *Seismic Evaluation and Retrofit of Existing Buildings*. Where RP 8 makes no specific provision, this chapter adopts the provisions of the 2018 IEBC Prescriptive Compliance Method. This chapter also makes revisions to specific sections in RP 8 and the 2018 IEBC.

- **CHAPTER 5 – NONBUILDING STRUCTURES.** This chapter lists the names of various standards and other guidelines to be followed for the design of highway bridges, railroad bridges, tanks for liquid storage, tanks for petroleum storage, environmental engineering concrete structures, prestressed concrete tanks, water treatment facility structures, transmission towers and poles, antenna towers, and pedestrian bridges.
- **CHAPTER 6 – MODIFICATIONS TO THE IBC FOR CRITICAL HEALTHCARE FACILITIES.** This chapter contains a number of additional requirements for certain critical healthcare facilities identified in the chapter. The requirements are presented in the form of modifications to Chapters 16, 18, 19, 20, 21, and 22 of the IBC.
- **CHAPTER 7 – MODIFICATIONS TO ASCE 7 FOR CRITICAL HEALTHCARE FACILITIES.** This chapter contains a number of additional requirements for the same healthcare facilities within the scope of Chapter 6. The requirements are presented in the form of modifications to Chapters 11, 12, and 13 of ASCE 7.
- **Appendix A – REFERENCES.** The UFC has an extensive list of referenced public documents. The primary references for this UFC are the 2018 IBC and ASCE 7-16.
- **Appendix B – BEST PRACTICES.** This chapter provides useful recommendations and guidance on a number of important topics such as building drift limits, impact resistant glazing, wind and seismic loads on photovoltaic arrays, etc.
- **Appendix C – ALTERNATE DESIGN PROCEDURE FOR BUILDINGS AND OTHER STRUCTURES IN RISK CATEGORY IV.** For buildings assigned to Risk Category IV, those that are “essential” because of their military function or post-earthquake recovery role, the 2018 IBC /ASCE 7-16 requires higher design lateral loads and more stringent structural detailing procedures than those for buildings assigned to Risk Category I, II, or III. Applying nonlinear analysis procedures may result in more economical or better-performing Risk Category IV buildings than linear elastic procedures can provide. While the 2018 IBC/ASCE 7-16 permits nonlinear static analysis procedures, it provides little guidance on how to perform them. Appendix C presents optional nonlinear static analysis procedures that may be used for Risk Category IV buildings. Apply the optional

nonlinear procedures outlined in Appendix C only with the approval of the Contracting Officer.

- Appendix D – GUIDANCE FOR SEISMIC DESIGN OF NONSTRUCTURAL COMPONENTS. Appendix D provides guidance for seismic design of nonstructural components. Requirements for design of nonstructural components in this UFC are supplemented by guidance provided in this appendix.
- Appendix E – MECHANICAL AND ELECTRICAL COMPONENT CERTIFICATION. Appendix E provides guidance in addition to what is available in ASCE 7-16 Section 13.2.2 on certification of mechanical and electrical components.
- Appendix F – ABBREVIATIONS. This appendix lists all the abbreviated terms used in this UFC.
- Appendix G – MINIMUM UNIFORMLY DISTRIBUTED LIVE LOADS, L_0 , AND MINIMUM CONCENTRATED LIVE LOADS. This appendix contains Table G-1, which replaces Table 1607.1 of the 2018 IBC, and includes additional occupancy or use classification for military facilities that are shown in bold italics

1-6 COMMENTARY.

Limited commentary has been provided in the chapters. Section designations for such commentary are preceded by a “[C]”, and the commentary narrative is shaded.

1-7 OTHER CRITERIA.

Military criteria other than those listed in this document may be applicable to specific types of structures. Such structures must meet the additional requirements of the applicable military criteria.

1-7.1 General Building Requirements.

Comply with UFC 1-200-01, DoD Building Code (General Building Requirements). UFC 1-200-01 provides applicability of model building codes and government unique criteria for typical design disciplines and building systems, as well as for accessibility, antiterrorism, security, high performance and sustainability requirements, and safety. Use this UFC in addition to UFC 1-200-01 and the UFCs and government criteria referenced therein.

1-7.2 Progressive Collapse Analysis and Design.

Apply UFC 4-023-03, *Design of Buildings to Resist Progressive Collapse*, if required by UFC 4-010-01, *DoD Minimum Antiterrorism Standards for Buildings*. UFC 3-301-01 and UFC 4-023-03 both apply in that case. Design in accordance with one does not guarantee compliance with the other.

1-7.3 Design of Risk Category V Structures.

An additional risk category not included in the 2018 IBC/ASCE 7-16, Risk Category V, has been added to address national strategic military assets. Structures in this risk category are designed to remain elastic during the MCE_R . Refer to UFC 3-301-02 for the design of all RC V structures.

CANCELLED

CANCELLED

This page intentionally left blank

CHAPTER 2 MODIFICATIONS TO IBC

2-1 IBC CHAPTER 1 - SCOPE AND ADMINISTRATION.

2-1.1 Section 101 – GENERAL.

101.4.7 – Existing Buildings [Supplement]

For seismic evaluation and retrofit of existing buildings, the provisions of Chapter 4 of this UFC apply to all matters governing the *repair, alteration*, change of occupancy, acquisition, *addition* and relocation. Where the provisions of Chapter 4 and the 2018 IEBC are in conflict, those of Chapter 4 govern. Section 116 - UNSAFE STRUCTURES AND EQUIPMENT.

[C] 101.4.7 – Existing Buildings [Supplement]

The purpose of this [Supplement] must direct users to specific provisions for seismic evaluation and retrofit of existing buildings. In the 2012 IBC, the existing building provisions were in Chapter 34. In the 2015 and 2018 editions of the IBC, Chapter 34 consists solely of the following statement: “Action taken during the 2012 Code Development Process removed Chapter 34, Existing Structures, from the IBC. The provisions of this chapter are contained in the International Existing Building Code. See Section 101.4.7.” The 2018 IEBC contains three alternative compliance methods; the Prescriptive Compliance Method follows the same layout and philosophy as the previous IBC Chapter 34. Chapter 4 of this UFC cites a federal recommended practice document (ICSSC RP 8) and a national standard (ASCE 41-13) for seismic evaluation and retrofit of existing buildings. The chapter provides some modifications and clarifications to the requirements of RP 8 and ASCE 41-13.

116.5 – Restoration [Replacement]

Where the structure or equipment determined to be unsafe by the AHJ is restored to a safe condition, to the extent that *repairs, alterations* or *additions* are made or a change of occupancy occurs during the restoration of the structure, such *repairs, alterations, additions* or change of occupancy must comply with the requirements of Sections 101.4.7, 105.2.2 and Chapter 4 of this UFC, as applicable.

2-2 IBC CHAPTER 2 – DEFINITIONS.

2-2.1 Section 202 – DEFINITIONS.

STRUCTURAL ENGINEER OF RECORD (SER) [Addition]

The Structural Engineer of Record (SER) is a registered design professional who performs or supervises the analysis, design, and document preparation for the building structural system. The SER is responsible for the design of the primary structural system, which is the completed combination of elements, which serve to support the building's self-weight, applicable live loads and environmental loads such as wind, seismic, and thermal.

2-3 IBC CHAPTER 4 – SPECIAL DETAILED REQUIREMENTS BASED ON OCCUPANCY AND USE.

2-3.1 Section 423 – STORM SHELTERS.

423.3 – Critical Emergency Operations [Replacement]

In hurricane-prone regions (see ASCE 7 Section 26.2) and/or in areas where shelter design wind speeds for tornados equal or exceed 250 mph (see Figure 304.2(1) of ICC 500), the following facilities must comply with Table 1604.5 as Risk Category IV structures and must be provided with a storm shelter constructed in accordance with ICC 500:

- 911 call stations
- Emergency operation centers
- Fire and ambulance stations
- Police stations
- Critical national defense functions that must be manned continuously and for which there is no redundant capability at a different location.

2-4 IBC CHAPTER 16 - STRUCTURAL DESIGN.

2-4.1 Section 1603 - CONSTRUCTION DOCUMENTS.

1603.1.5 – Earthquake Design Data Item 3 [Replacement]

3. Mapped spectral response acceleration parameters, S_s and S_1 , must be indicated. If the data are based on site-specific response analysis, this must be noted. Site-specific source data must also include whether response spectrum or time-history analyses were performed.

1603.1.10 – Systems/Components Requiring Special Inspection for Seismic Resistance [Addition]

Construction documents and specifications must be prepared for those systems and components requiring special inspection for seismic resistance, as specified in 2018 IBC Section 1705.12 as modified by appropriate special inspection section in UFC 1-200-01 and by the SER. Reference to seismic standards in lieu of detailed drawings is acceptable.

1603.2 - Delegated Engineered Systems [Addition]

The SER for a structure may delegate responsibility for the design of systems or component parts of the structure to a qualified delegated registered professional engineer. Both the SER for the structure and the delegated engineer must comply with the requirements of this UFC.

Exception: The SER must design and detail all primary lateral force resisting system connections for wind and seismic forces, including steel connections. This provision does not preclude a pre-engineered structure manufacturer from designing primary lateral force-resisting connections where the engineer for the pre-engineered structure is also the SER. This would be the case with pre-engineered metal buildings and pre-engineered parking garages, for example. /1/

The following are some examples of optional delegated designs:

- a. Prefabricated wood components
- b. Cast-in-place post-tensioned concrete structural systems
- c. Precast, prestressed concrete components
- d. Open web steel joists and joist girders
- e. Specialty foundation systems
- f. Simple (shear only) steel connections (lateral must be designed by SER).
- g. Cold-formed steel joist/stud/truss framing and pre-fabricated components
- h. Seismic design and anchorage of nonstructural components
- i. Proprietary track for under-hung cranes and monorails
- j. Autoclaved aerated concrete
- k. Cross-laminated timber connections

The delegated engineer must sign and seal all work they design. The SER must review all submittals that have been signed and sealed by the delegated engineer, to verify compliance with the design intent and the specified design criteria and to ensure coordination with the contract documents and other shop drawings. All submittals from the delegated engineer must be approved by the SER prior to the start of fabrication of the system or component part and prior to any field construction that may be affected by the system or component part.

2-4.2 **Section 1604 - GENERAL DESIGN REQUIREMENTS.**

1604.3 - Serviceability [Supplement]

The SER must ensure that the maximum allowable frame drift is suitable for the proposed structure considering occupancy, use/function, and all details of construction. See ASCE 7-16 Appendix C “Serviceability Considerations” including commentary, and Section B-1.1 of UFC 3-301-01 for additional guidance.

In the wind design of a building or non-building structure, lateral drift must not exceed $H/480$ based on a wind speed with a 10 year MRI. See Figure CC.2-1 of ASCE 7 for wind speeds with a 10 year MRI. Consideration must be given to cladding systems when evaluating lateral drift as a more stringent drift limitation may be appropriate for certain cladding system.

1604.3.1 - Deflections [Replacement]

Deflections of structural members must not exceed the most restrictive of the limitations of Sections 1604.3.2 through 1604.3.5 or those permitted by Table 1604.3, or Table 2-1 of UFC 3-301-01.

Table 2-1 Wind Induced Deflection Limits for Framing Supporting Exterior Wall Finishes^{a,b}

Brick veneer	$L/600$
Exterior Insulation Finish Systems	$L/240$
Cement board	$L/360$
Stone Masonry	VERIFY WITH STONE SUPPLIER
Plywood and Wood-Based Structural-Use Panels	$L/240$
Gypsum sheathing	$L/240$
Metal or vinyl siding and insulated metal panel	$L/240$

Notes to Table 2-1, “Lateral Deflection Limits for Framing Supporting Exterior Wall Finishes”

- a. The wind load is permitted to be taken as 0.42 times the “component and cladding” loads for the purpose of determining the deflection limits herein.
- b. L must be calculated as $L = k \cdot l$, where k is the theoretical effective length factor, and l is the actual member length.

Table 1604.5 [Replacement]

Replace Table 1604.5 of the IBC with Table 2-2 of this UFC. All references in the IBC to Table 1604.5 must be interpreted as a reference to Table 2-2 of this UFC. Items that are different from those in 2018 IBC Table 1604.5 are shown in italics.

1604.11 - Fall Prevention and Protection [Addition]

To protect personnel during occupancy and maintenance phases, consider fall hazards at the planning and design phase of a project and eliminate them to the maximum extent possible. Also consider safe access to work location at heights. Fall prevention and protection measures are prescribed in:

- 29 CFR 1910, Subpart D
- ANSI/ASSE A1264.1
- ANSI/ASSE Z359.6

When elimination or prevention of fall hazards is not feasible, include in design certified and labeled anchorages that are conveniently located to perform the work safely. The anchorages and the structural elements that support these anchorages must meet the requirements of 2018 IBC Section 1607.10.4, as modified by this UFC

Where fall protection is required near weight-handling equipment, prevent conflicts between the weight-handling equipment and fall protection measures.

Table 2-2 Risk Category of Buildings and Other Structures

Risk Category	Nature of Occupancy	Seismic Factor I_E	Snow Factor I_s	Ice Factor I_i	Tsunami Factor I_{TSU}	DoD Sea Level Rise (SLR) Scenario ^f
I	<p>Buildings and other structures that represent a low hazard to human life in the event of failure, including, but not limited to:</p> <ul style="list-style-type: none"> • Agricultural facilities • Certain temporary facilities • Minor storage facilities 	1.00	0.8	0.80	N/A Tsunami design not required	N/A
II	<p>Buildings and other structures except those listed in Risk Categories I, III, IV and V</p>	1.00	1.00	1.00	1.00	Low (2065)
III	<p>Buildings and other structures that represent a substantial hazard to human life or represent significant economic loss in the event of failure, including, but not limited to:</p> <ul style="list-style-type: none"> • Buildings and other structures whose primary occupancy is public assembly with an occupant load greater than 300 people^d • Buildings and other structures containing <i>elementary school, secondary school, or daycare facilities</i> with an occupant load greater than 250^d • Buildings and other structures containing <i>adult education facilities, such as colleges and universities</i>, with an occupant load greater than 500^d • Group I-2, Condition 1 occupancies with 50 or more care recipients^e • Group I-2, Condition 2 occupancies not having emergency surgery or emergency treatment facilities^e • Group I-3 occupancies • Any other occupancy with an occupant load greater than 5,000^{a,d} • Power-generating stations; water treatment facilities for potable water, wastewater treatment facilities, and other public utility facilities that are not included in Risk Categories IV and V • Buildings and other structures not included in Risk Categories IV and V containing quantities of toxic, flammable, or explosive materials that: Exceed maximum allowable quantities per control area as given in Table 307.1(1) or 307.1(2) or per outdoor control area in accordance with <i>NFPA 1: Fire Code</i>; and are sufficient to pose a threat to the public if released.^b • <i>Facilities having high-value equipment (including aircraft maintenance hangers^d), as designated by the AHJ</i> 	1.25	1.10	1.25	1.25	Medium (2065)

Risk Category	\1\Nature of Occupancy	Seismic Factor I_E	Snow Factor I_S	Ice Factor I_I	\1\Tsunami Factor I_{Tsu}	\1\DoD Sea Level Rise (SLR) Scenario ^f
IV	<p>Buildings and other structures designed as essential facilities, including, but not limited to:</p> <ul style="list-style-type: none"> • Group I-2, Condition 2 occupancies having emergency surgery or emergency treatment facilities ^e • Ambulatory care facilities having emergency surgery or emergency treatment facilities ^e • Fire, rescue, and police stations, and emergency vehicle garages ^e • Designated earthquake, hurricane, or other emergency shelters ^e • Designated emergency preparedness, communication, and operation centers, and other facilities required for emergency response ^e • Power-generating stations and other utility facilities required as emergency backup facilities for Risk Category IV structures. ^e • Buildings and other structures containing quantities of highly toxic materials that: <ul style="list-style-type: none"> Exceed maximum allowable quantities per control area as given in Table 307.1(2) or per outdoor control area in accordance with <i>NFPA 1, Fire Code</i>; and are sufficient to pose a threat to the public if released. ^b • <i>Air traffic control tower (ATCT), Radar Approach Control Facility (RACF) and air traffic control centers unless the AHJ determines that the facility is classified as a non-essential facility and is not required for post-disaster operations (i.e. minor facility, where an alternate temporary control facility is available, auxiliary outlying field, etc.). Contact the AHJ for additional guidance.</i> • <i>Emergency aircraft hangars that house aircraft required for post-disaster emergency response; if no suitable back up facilities exist</i> • <i>Buildings and other structures not included in Risk Category V, having DoD mission-essential command, control, primary communications, data handling, and intelligence functions that are not duplicated at geographically separate locations, as designated by the using agency.</i> ^e • <i>Water storage facilities and pump stations required to maintain water pressure for fire suppression.</i> 	1.50	1.20	1.25	1.25	High (2065) ^g
V^c	<p>Facilities designed as national strategic military assets, including, but not limited to:</p>	1.0	1.50	1.50	1.25/1/	Highest (2065) ^{g/1/}

Risk Category	\1\Nature of Occupancy	Seismic Factor <i>I_E</i>	Snow Factor <i>I_S</i>	Ice Factor <i>I_I</i>	\1\Tsunami Factor <i>I_{Tsu}</i>	\1\DoD Sea Level Rise (SLR) Scenario ^f
	<ul style="list-style-type: none"> • Key national defense assets (e.g. National Missile Defense facilities) without geographically separated redundant capability, as approved by the AHJ • Facilities involved in operational missile control, launch, tracking, or other critical defense capabilities • Emergency backup power-generating facilities required for primary power for Category V occupancy • Power-generating stations and other utility facilities required for primary power for Category V occupancy, if emergency backup power generating facilities are not available <p>Facilities involved in storage, handling, or processing of nuclear, chemical, biological, or radiological materials, where structural failure could have widespread catastrophic consequences, as designated by the AHJ./1/</p>					

Notes to Table 2-2, “Risk Category of Buildings and Other Structures”

- a. For purposes of occupant load calculations, occupancies required by Table 1004.5 to use gross floor area are permitted to use net floor area to determine the total occupant load.
- b. Where approved by the AHJ, the classification of buildings and other structures as Risk Category III or IV based on their quantities of toxic, highly toxic or explosive materials is permitted to be reduced to Risk Category II, provided it can be demonstrated by hazard assessment in accordance with Section 1.5.3 of ASCE 7 that a release of the toxic, highly toxic or explosive material is not sufficient to pose a threat to the public.
- c. Risk Category V has been added to address national strategic military assets. Structures in this risk category are designed to remain elastic during the MCER. Refer to UFC 3-301-02 for the design of all RC V structures.
- d. \1\These facilities may be designed for Tsunami Risk Category I or II as designated by the AHJ.
- e. These facilities may be designed for Tsunami Risk Category I, II or III as designated by the AHJ if adequate equivalent facilities are available outside of the tsunami inundation zone or if adequate equivalent facilities within the inundation zone have been designed for the effects of tsunami.

- f. Use the site-specific value from the DoD Regional Sea Level (DRSL) database corresponding to the designated scenario (low/medium/high/highest) for the year 2065. The DRSL database is available at <https://sealevelscenarios.serdp-estcp.org>.
- g. Subject to approval by the AHJ, a DoD 2065 sea level rise scenario of Medium may be used for Risk Category IV and V structures when designing for a combination of tsunami and sea level rise. Reference section 3-3.3 within this UFC for specific limitations and requirements./1/

1604.12 - Expansion Joints [Addition]

Follow the recommendations in *NAS Technical Report No. 65* for spacing of expansion joints.

2-4.3 Section 1605 – LOAD COMBINATIONS

1605.1.2 – Structural Members Sensitive to Vertical Ground Motion [Addition]

Where the design earthquake spectral response acceleration parameter at short periods, S_{DS} , is greater than 1.0g, the components from building and nonbuilding structures listed below must be designed for additional load combinations given in Sections 1605.2.2, Section 1605.3.1.3 and 1605.3.2.2 for Strength Design, Allowable Stress Design (basic load combinations) and Allowable Stress Design (alternative basic load combinations), respectively.

Building Structures:

- horizontal or nearly horizontal structural members spanning 65 ft or more
- horizontal or nearly horizontal cantilever components longer than 16 ft
- horizontal or nearly horizontal prestressed components
- building components, excluding foundations, in which demands due to gravity loads exceed 80% of the nominal strength of the component
- horizontal structural elements supporting discontinuous vertical elements of the gravity force-resisting system
- base-isolated structures

Nonbuilding Structures:

- long-span roof structures (e.g. stadiums or high bay aircraft maintenance hangars)
- electric power generation facilities

Exception: Nonbuilding structures addressed by ASCE 7-16 Section 15.1.4 are not required to comply with this section.

[C] 1605.1.2 Structural Members Sensitive to Vertical Ground Motion [Addition]

The effects of vertical earthquake ground motion on buildings have traditionally been given much less attention than the effects of horizontal ground motion. This is largely due to the belief that the peak vertical ground acceleration is considerably smaller than the peak horizontal ground acceleration. A fairly large safety factor against static vertical loads also exists in engineered buildings. As a result, it is generally considered adequate to include the effects of vertical ground motions in the simplified form of $0.2S_{DS}D$, as done in the IBC and the ASCE 7-16 standard for many years. However, certain structural members are particularly vulnerable to vertical ground motions, and require more explicit consideration of such ground motions in their design. This [Addition] addresses those specific members by incorporating additional provisions for design considering vertical ground motions.

The threshold value of $S_{DS} > 1.0g$ was derived from a similar requirement in the 2004 edition of Eurocode 8, which specified the peak vertical ground acceleration, a_{vg} , to be greater than $0.25g$ for its special provisions related to vertical ground motions to apply. The derivation is as shown below:

1. From the vertical ground motion response spectrum given in ASCE 7-16 Section 11.9.2, the ratio of the peak vertical acceleration (spectral acceleration at $T = 0$) and the maximum vertical spectral acceleration (flat top portion of the response spectrum) is $0.3/0.8 = 0.375$.
2. The maximum vertical spectral acceleration has been traditionally assumed to be $2/3SDS$.
3. So, the peak vertical ground acceleration can be expressed in terms of SDS as:
 $avg = 0.375 \times (2/3SDS) = 0.25SDS$
4. So, $avg > 0.25g \Rightarrow SDS > 1.0g$

1605.2.2 – Additional Load Combinations for Vertical Ground Motions [Addition]

The following additional load combinations with seismic load effects must be considered for elements of buildings and nonbuilding structures specified in Section 1605.1.2.

Where the prescribed seismic load effect, $E = f(E_v, E_h)$, defined in ASCE 7-16 Section 12.4.2 or 12.14.3.1, is combined with the effects of other loads, the following seismic load combinations apply:

$$1.2(D + F) + 1.0E_{v0} + 0.3E_h + f_1L + 1.6H + f_2S \quad (\text{Equation 16-5A})$$

$$0.9(D + F) - E_{v0} + 0.3E_h + 1.6H \quad \text{(Equation 16-7A)}$$

Where the seismic load effect with overstrength, $E_m = f(E_v, E_{mh})$, defined in ASCE 7-16 Section 12.4.3, is combined with the effects of other loads, the following seismic load combinations apply:

$$1.2(D + F) + 1.0E_{v0} + 0.3E_{mh} + f_1L + 1.6H + f_2S \quad \text{(Equation 16-5A)}$$

$$0.9(D + F) - E_{v0} + 0.3E_{mh} + 1.6H \quad \text{(Equation 16-7A)}$$

The effect of vertical ground motion, E_{v0} , can be determined from one of the following:

- $E_{v0} = 0.67S_{DS}D$
- E_{v0} is determined by direct analysis using the design vertical response spectrum given in ASCE 7-16 Section 11.9.

[C] 1605.2.2 – Additional Load Combinations for Vertical Ground Motions [Addition]

The additional load combinations were derived using the 100+30 rule of combining the effects from orthogonal seismic loads. The code-specified vertical ground motion effect ($0.2S_{DS}D$) can be derived by first assuming peak vertical ground motion component to be $2/3^{\text{rd}}$ of the corresponding peak horizontal component, and then combining 30% of that ($0.3 \times 0.67S_{DS} = 0.2S_{DS}$) with 100% of the horizontal seismic load effects. This section simply adds two more load combinations where 100% of the vertical seismic load effect is combined with 30% of the horizontal seismic load effect.

1605.3.1.3 – Additional Load Combinations for Vertical Ground Motions [Addition]

The following additional load combinations with seismic load effects must be considered for elements of buildings and nonbuilding structures specified in Section 1605.1.2.

Where the prescribed seismic load effect, $E = f(E_v, E_h)$, defined in ASCE 7-16 Section 12.4.2 or 12.14.3.1, is combined with the effects of other loads, the following seismic load combinations apply:

$$D + H + F + 0.7E_{v0} + 0.21E_h \quad \text{(Equation 16-12A)}$$

$$D + H + F + 0.75(0.7E_{v0} + 0.21E_h) + 0.75L + 0.75S \quad \text{(Equation 16-14A)}$$

$$0.6(D + F) - 0.7E_{v0} + 0.21E_h + H \quad \text{(Equation 16-16A)}$$

Where the seismic load effect with overstrength, $E_m = f(E_v, E_{mh})$, defined in ASCE 7-16 Section 12.4.3, is combined with the effects of other loads, the following seismic load combinations apply:

$$D + H + F + 0.7E_{v0} + 0.21E_{mh} \quad \text{(Equation 16-12A)}$$

$$D + H + F + 0.75(0.7E_{v0} + 0.21E_{mh}) + 0.75L + 0.75S \quad \text{(Equation 16-14A)}$$

$$0.6(D + F) - 0.7E_{v0} + 0.21E_{mh} + H \quad \text{(Equation 16-16A)}$$

The effect of vertical ground motion, E_{v0} , can be determined from one of the following:

- $E_{v0} = 0.67S_{DS}D$
- E_{v0} is determined by direct analysis using the design vertical response spectrum given in ASCE 7-16 Section 11.9.

[C] 1605.3.1.3 – Additional Load Combinations for Vertical Ground Motions [Addition]

See the commentary to Section 1605.2.2 above for some background on how the additional load combinations were derived.

1605.3.2.2 – Additional Load Combinations for Vertical Ground Motions [Addition]

The following additional load combinations with seismic load effects must be considered for elements of buildings and nonbuilding structures specified in Section 1605.1.2.

Where the prescribed seismic load effect, $E = f(E_v, E_h)$, defined in ASCE 7-16 Section 12.4.2 or 12.14.3.1, is combined with the effects of other loads, the following seismic load combinations apply:

$$D + L + S + E_{v0}/1.4 + E_h/4.6 \quad \text{(Equation 16-21A)}$$

$$0.9D - E_{v0}/1.4 + E_h/4.6 \quad \text{(Equation 16-22A)}$$

Where the seismic load effect with overstrength, $E_m = f(E_v, E_{mh})$, defined in ASCE 7-16 Section 12.4.3, is combined with the effects of other loads, the following seismic load combinations apply:

$$D + L + S + E_{v0}/1.4 + E_{mh}/4.6 \quad \text{(Equation 16-21A)}$$

$$0.9D - E_{v0}/1.4 + E_{mh}/4.6 \quad \text{(Equation 16-22A)}$$

The effect of vertical ground motion, E_{v0} , can be determined from one of the following:

- $E_{v0} = 0.67S_{DS}D$
- E_{v0} is determined by direct analysis using the design vertical response spectrum given in ASCE 7-16 Section 11.9.

[C] 1605.3.2.2 – Additional Load Combinations for Vertical Ground Motions [Addition]

See the commentary to Section 1605.2.2 above for some background on how the additional load combinations were derived.

2-4.4 **Section 1607 - LIVE LOADS.**

1607.1 - General [Replacement]

Live loads are those loads defined in Section 1607.1. Table G-1 of this UFC defines minimum uniformly distributed live loads and minimum concentrated live loads for the design of structures. Table G-1 is IBC Table 1607.1 with additional Occupancy or Use classifications for military facilities. The classifications that have been added to IBC Table 1607.1 are shown in bold italics within Table G-1.

Table 1607.1 [Replacement]

Replace Table 1607.1 of the IBC with Table G-1 of this UFC. (All references in the IBC to Table 1607.1 must be interpreted as references to Table G-1 of this UFC.)

1607.7.1 - Loads [Replacement]

Where a structure does not restrict access for vehicles that exceed a 10,000 pound (4536 kg) gross vehicle weight rating, those portions of said structure subject to such loading must be designed using the vehicular live loads, including consideration of impact and fatigue, in accordance with the AASHTO Bridge Design Specification.

1607.10.4 – Fall arrest and lifeline anchorages [Supplement]

Fall arrest anchorages must be capable of supporting at least 5,000 pounds per person attached, or be designed, installed and used as part of a complete fall arrest system which maintains a safety factor of at least 2.0 under the supervision of a qualified person. See ANSI/ASSE Z359.6 for additional requirements and design guidance (Note: the 1.6 load factor used in Z359.6 for active forces must be replaced by 2.0).

1607.10.5 - Hangers [Addition]

The design live load on hanger bay walls supporting floors and balconies must be increased by 33 percent to account for impact.

1607.12 - Distribution of Floor Loads [Supplement]

Add the following to the end of the paragraph: “Partial floor live load must be distributed per Section 4.3.3 of ASCE 7”.

2-4.5 **Section 1608 - SNOW LOADS.**

1608.4 - Specific Locations within the United States [Addition]

Ground snow loads at DoD installations within the United States and its territories and possessions are identified using the structural load data tool hosted on the Whole Building Design Guide website at

<https://www.wbdg.org/additional-resources/tools/ufcsldt>

Exception: Ground snow load at locations in the State of Montana must be determined from <http://snowload.montana.edu/>.

At locations where the ground snow load is not provided, use the best locally available criteria. /1/

1608.5 - Specific Locations Outside of the United States [Addition]

Ground snow loads at specific locations outside of the United States and its territories and possessions are identified using the structural load data tool hosted on the Whole Building Design Guide website [1\www.wbdg.org/1/](https://www.wbdg.org/)

<https://www.wbdg.org/additional-resources/tools/ufcsldt>

At locations where the ground snow load is not provided, use the best locally available [1\criteria.1/](#)

1608.6 - Snow Load Case Studies [Addition]

Snow load case studies may be done to clarify and refine snow loadings at site-specific locations with the approval of the AHJ. Where required by the AHJ, a site-specific study must be conducted if the ground snow load is greater than 30 psf (1.4KPa). The methodology used to conduct snow load case studies at site-specific locations is presented in the Cold Regions Research and Engineering Laboratory (CRREL) report “Database and Methodology for Conducting Site Specific Snow Load Case Studies for the United States.”

2-4.6 **Section 1609 - WIND LOADS.**

1609.1.1 – Determination of Wind Loads [Supplement]

Add the following to the list of exceptions:

7. For winds parallel to the ridge of open buildings, the wind load delivered to the main wind force resisting system from the bare frames or partially clad end walls must be determined in accordance with the provisions of ASCE 7-16 Section 28.3.5.

1609.1.2 – Aircraft Hangar Wind Loads [Addition]

Wind load on main wind force resisting system of aircraft hangars must be determined based on the following conditions:

- Hangar doors closed for winds at the maximum design velocity. Calculate the structural forces based upon the assumption of a “partially enclosed building.” It is permissible to use the large volume reduction factor of ASCE 7 in determining the design wind pressures. Assume that a 1-inch (25-mm) strip around the perimeter of all hangar door panels is an opening and combine this with the area of all unshielded fenestration.
- Hangar doors open to the maximum extent possible with a wind velocity of 60 mph (97 km/h). Calculate the structural forces upon the assumption of a “partially enclosed building.” Use the total open door area in the large volume reduction factor calculation.

1609.2.4 - Vertical Lift Fabric Hangar Doors (VLFD) [Addition]

Vertical Lift Fabric Doors are prohibited within windborne debris regions.

In addition to windborne debris regions, VLFD's are prohibited for use in aircraft maintenance hangars where risk category III wind speeds equal or exceed wind speeds defining a windborne debris region. Namely, 130 mph (58 m/s) within one mile of the coastal mean high-water line or 140 mph (63.6 m/s) anywhere.

[C] 1609.2.4 – Vertical Lift Fabric Hangar Doors (VLFD) [Addition]

VLFD's are currently prohibited for use in windborne debris regions due to failures experienced during hurricane Michael. These failures were predominately caused by wind driven debris. Additionally, the DoD has prohibited VLFD use where hangar design wind speeds are consistent with windborne debris regions, which provides commensurate design wind speed protection against windborne debris for Risk Category III hangar facilities.

1609.2.5 – Roll Up Doors and Sectional Doors in Hurricane Prone Regions [Addition]

In hurricane prone regions, warehouse and/or garage roll up doors or sectional doors must be pressure tested for components and cladding design wind pressure and shown to pass in accordance with ANSI/DASMA 108, Standard Method for Testing Sectional Garage Doors and Rolling Doors. This requirement must be noted on the construction drawings in addition to the project specifications. The SER must specify the components and cladding design wind pressure for garage/sectional doors on the construction drawings.

1609.3.1 - Wind Speed Conversion [Replacement]

When required, the basic design wind speed can be converted to an allowable stress design wind speed, V_{asd} , using Equation 16-33a.

$$V_{asd} = \sqrt{0.6}V \quad (\text{Equation 16-33a})$$

When required, the basic design wind speed can be converted to a fastest-mile wind speed, V_{fm} , using Equation 16-33b.

$$V_{fm} = (\sqrt{0.6}V - 10.5) / 1.05 \quad (\text{Equation 16-33b})$$

1609.3.2 - Specific Locations within the United States [Addition]

Basic design wind speeds at DoD installations within the United States and its territories and possessions can be identified using the structural load data tool hosted on the Whole Building Design Guide website at:

<https://www.wbdg.org/additional-resources/tools/ufcsldt>

1609.3.3 - Specific Locations Outside of the United States [Addition]

Basic design wind speeds at specific locations outside of the United States and its territories and possessions can be identified using the structural load data tool hosted on the Whole Building Design Guide website at:

<https://www.wbdg.org/additional-resources/tools/ufcsldt>

At locations where the basic design wind speed is not provided, use the best locally available information. For additional guidance, contact the AHJ.

2-4.7 Section 1613 - EARTHQUAKE LOADS.

1613.1 – Scope [Supplement]

For all structures, wherever ASCE 7-16 Table 12.2-1 is referenced, it must be replaced by Table 3-1 of this UFC.

[C] 1613.1 – Scope [Supplement]

Although Chapter 14 of ASCE 7-16 is not adopted by the 2018 IBC, occasional references to ASCE 7-16 Chapter 14 sections are made in this UFC.

1613.2.1.1 - Specific Locations within the United States [Addition]

Seismic parameters at DoD installations within the United States and its territories and possessions are can be identified using the structural load data tool hosted on the Whole Building Design Guide website at

<https://www.wbdg.org/additional-resources/tools/ufcsldt>

1613.2.1.2 - Specific Locations Outside of the United States [Addition]

Seismic ground motion parameters at specific locations outside of the United States and its territories and possessions can be identified using the structural load data tool hosted on the Whole Building Design Guide website at

<https://www.wbdg.org/additional-resources/tools/ufcsldt>.

For locations not shown, the best available information must be used with the approval of the AHJ. Appendix G includes available seismic spectral acceleration maps at selected locations outside of the United States. These maps may be used to interpolate the seismic ground motions at locations that are not identified in the above noted structural load data tool.

1613.2.1.3 – Site Specific Seismicity Study Process [Addition]

The site-specific ground motion procedures in Chapter 21 of ASCE 7 may be used to determine ground motions for any structure.

1613.3 – Ballasted Photovoltaic Panel Systems [Replacement]

Ballasted photovoltaic panel systems are not permitted.

[C] Ballasted Photovoltaic Panel Systems [Replacement]

Ballasted systems are specifically disallowed by UFC 3-110-03, *Roofing*.

1613.4 - Procedure for Determining MCE_R and Design Spectral Response Accelerations [Addition]

Ground motion accelerations, represented by response spectra and coefficients derived from these spectra, must be determined in accordance with the procedure of ASCE 7-16 Sections 11.4.2-11.4.6, or the site-specific procedure of

ASCE 7-16 Section 11.4.8. Subject to approval by the AHJ, a site-specific response analysis using the procedure of ASCE 7-16 Section 11.4.8 may be used in determining ground motions for any structure. Such analysis needs to include justification for its use in lieu of the mapped ground motion data that are described below.

A site-specific response analysis using the procedures of ASCE 7-16 Section 11.4.8 must be used for structures on sites classified as Site Class F (see ASCE 7-16 Section 20.3.1), unless the following condition is applicable:

The mapped Risk-Targeted Maximum Considered Earthquake (MCE_R) spectral response acceleration at short periods, S_s , and the mapped MCE_R spectral response acceleration at 1-second period, S_1 , as determined in accordance with UFC 3-301-01, are less than or equal to 0.25 and 0.10, respectively.

S_s and S_1 must be determined for installations within the United States from Section 1613.2.1.1, added by this UFC. For installations located outside the United States, S_s and S_1 must be determined from Section 1613.2.1.2, added by this UFC.

2-4.8 **Section 1615 – TSUNAMI LOADS.**

1615.1 – General [Replacement]

The design and construction of buildings and structures located in a Tsunami Design Zone, as defined by the Tsunami Design Geodatabase or by DoD tsunami mapping for at risk OCONUS installations, must be in accordance with Chapter 6 of ASCE 7.

For at risk Pacific and Pacific Rim OCONUS installations, see the following link to access tsunami inundation and flow maps.

Link here:

<https://www.wbdg.org/ffc/dod/unified-facilities-criteria-ufc/tsunami-inundation-mapping>

Maps are formatted as KMZ files, which can be downloaded and opened with Google Earth, ARCGIS, or an equivalent KMZ compatible geo map application.

Section 1616 – STRUCTURAL INTEGRITY [Deletion].

Delete this section in its entirety.

2-5 IBC CHAPTER 17 - SPECIAL INSPECTIONS AND TESTS.

2-5.1 **Section 1701 – GENERAL.**

1701.1 - Scope [Supplement]

Add the following paragraph:

Contractual relationships and the composition of the architect / engineer / construction (AEC) team differ from that contemplated by the language of 2018 IBC, when doing DoD construction. When performing design or construction using typical methods for in-house design, AE design, and contracting for construction, 2018 IBC/ASCE 7-16 terms of Authority Having Jurisdiction and Building Official must be as defined in MIL STD 3007

Unless noted otherwise, apply the following substitutions for implementing the IBC:

- “Building official” - defined as “Authority Having Jurisdiction” as referenced in MIL STD 3007).
- “Owner” - defined as “Authority Having Jurisdiction”
- “Permit applicant” - defined as “contractor”

[C] 1701.1 - Scope [Supplement]

The context of the IBC terms “permit”, “permit application”, “permit applicant”, and “owner” must be modified for DoD projects. DoD functions as the building department/jurisdiction and the AHJ functions as the building official. When DoD advertises a project, the building permit is effectively implied/granted. However the overall project may still require other permits related to site storm water, air quality, demolition disposal, etc.

2-5.2 Section 1703 – APPROVALS.

1703.4 - Performance [Replacement]

New, unusual, or innovative materials, systems or methods previously untried may be incorporated into designs when evidence shows that such use is in the best interest of the Government from the standpoint of economy, lower life-cycle costs, and quality of construction. Supporting data, where necessary to assist in the approval of materials or assemblies not specifically provided for in the code, must consist of valid evaluation reports from International Code Council – Evaluation Service (ICC-ES), or other qualified testing and evaluation service with the prior approval of the AHJ.

1703.4.1 - Research and Investigation [Deletion]

Delete this section in its entirety.

1703.4.2 - Research Reports [Deletion]

Delete this section in its entirety.

2-5.3 **Section 1704 – SPECIAL INSPECTIONS AND TESTS, CONTRACTOR RESPONSIBILITY AND STRUCTURAL OBSERVATIONS.**

1704.2.3 Statement of special inspections. [Replacement]

Replace the first paragraph with the following:

The SER must submit a Statement of Special Inspections in accordance with Section 107.1. This statement must be in accordance with Section 1704.3. A template ‘Statement of Special Inspections’ and a template ‘Schedule of Special Inspections’ may be found on the WBDG at the following link under ‘related material’:

<https://www.wbdg.org/ffc/dod/unified-facilities-criteria-ufc/ufc-3-301-01>

1704.6 – Structural Observations [Replacement]

Replace the first paragraph with the following:

Where required by the provisions of Section 1704.6.1, 1704.6.2 or 1704.6.3 structural observations must be performed by the SER or their designated representative who must be a Registered Design Professional. Structural observation does not include or waive the responsibility for the inspections in Section 110 or the special inspections in Section 1705 or other sections of this code.

1704.6.1 – Structural Observations for Structures [Replacement]

Replace Item 1 with the following:

1 - The structure is classified as Risk Category IV in accordance with Table 2-2 of this UFC.

Replace Item 3 with the following:

3 – Such observation is required by the SER.

1704.6.2 – Structural Observations for Seismic Resistance [Replacement]

Replace Item 1 with the following:

1 - The structure is classified as Risk Category III or IV in accordance with Table 2-2 of this UFC.

Replace Item 3 with the following:

3 - The structure is assigned to Seismic Design Category E, is classified as Risk Category I or II in accordance with Table 2-2 of this UFC, and is greater than two stories above grade plane.

1704.7 – Special Inspector of Record [Addition]

When the provisions of Section 1704.6.1, 1704.6.2 or 1704.6.3 apply, the services of a Special Inspector of Record (SIOR) must be retained by the Contractor as a third party quality assurance agent (see UFC 1-200-01). The SIOR must be a licensed professional engineer in a state acceptable to the AHJ. The SIOR must submit qualifications acceptable to the AHJ.

1704.7.1 – Duties of the Special Inspector of Record (SIOR) [Addition]

The duties of the SIOR are defined in the following UFGS specifications;

Design-Bid-Build projects - specification 01 45 35

Design-Build projects - specification 01 45 35.05

1704.7.2 – Final Inspection Report [Addition]

When the work requiring Special Inspections is completed and all nonconforming items have been resolved to the satisfaction of the SER, the Contractor needs to notify the SIOR to submit a Final Special Inspection Report to the Contracting Officer, the SER, and the Contractor. The Final Special Inspection Report must attest that Special Inspection has been performed on all work requiring Special Inspection and that all nonconforming work and corrections of all discrepancies noted in the daily reports was resolved to the satisfaction of the SER and the Contracting Officer. The Final Special Inspection Report must be signed, dated, and must bear the seal of the SIOR.

2-5.4 Section 1705 – REQUIRED SPECIAL INSPECTIONS AND TESTS.

1705.3.3 – Adhesive Anchors [Addition]

The SER is required to determine the proof load (see ACI 318 Section 17.8.2.1) to be used for field-testing and to indicate in the construction documents which anchors are considered critical for testing.

1705.12.6 – Plumbing, Mechanical and Electrical Components [Supplement]

Add the following before the existing text:

Special inspection and verification are required for Designated Seismic Systems and must be performed as required by the Statement of Special Inspections, and the Schedule of Special Inspections, which must be prepared for each project. Templates for these documents may be downloaded the following link, under “Related Materials”:

<http://www.wbdg.org/ffc/dod/unified-facilities-guide-specifications-ufgs/ufgs-01-45-35>

The SER must prepare a Statement of Special Inspections in accordance with Section 1704 for the Designated Seismic Systems. The Statement of Special Inspections must define the periodic walk-down inspections that must be performed to ensure that the nonstructural elements satisfy life safety mounting requirements. The walk-down inspections must be performed by design professionals who are familiar with the construction and installation of mechanical and electrical components, and their vulnerabilities to earthquakes. The selection of the design professional is subject to the approval of the SER.

Designated Seismic Systems require a final walk-down inspection by the SER. The final review must be documented in a report. The final report prepared by the SER must include the following:

1. Record/observations of final site visit
2. Documentation that all required inspections were performed in accordance with the Statement of Special Inspections.
3. Documentation that the Designated Seismic Systems were installed in accordance with the construction documents and inspected in accordance with the requirements of Chapter 17, as modified by this section.

2-6 IBC CHAPTER 18 - SOILS AND FOUNDATIONS.

2-6.1 Section 1808 – FOUNDATIONS.

1808.4 - Vibratory Loads [Supplement]

Add the following to the end of the paragraph:

Design foundations in accordance with ACI 351.3R or ACI 350.4R, as applicable, and UFC 3-220-01.

1808.8.2.1 - Reinforcement [Addition]

For footings over three feet (914 mm) thick, the minimum ratio of reinforcement area to gross concrete area in each direction must be 0.0015, with not less than one-half nor more than two-thirds of the total reinforcement required placed near any one face. Use a bar size no smaller than No. 4 (#13M) with a maximum spacing of 12 inches (305 mm). [See 13.3.4.4 of 318-14]

2-6.2 Section 1809 - SHALLOW FOUNDATIONS.

1809.5.1 - Frost Line Depth [Addition]

Frost line depth at DoD installations within the United States and its territories and possessions and outside the United States are identified using the structural load data tool hosted on the Whole Building Design Guide website at

<https://www.wbdg.org/additional-resources/tools/ufcsldt>

At locations where frost line depths are not provided, use the best locally available information. For additional guidance, contact the AHJ. For guidance on the depth of footings considering frost, see Appendix Section B-2.3.

2-7 IBC CHAPTER 19 – CONCRETE.

2-7.1 Section 1901 – GENERAL.

1901.7 - Construction Joints [Addition]

Provide construction, contraction, and expansion joints in structures in accordance with ACI 224.3R and ACI 318, Section 26.5.6.

1901.10 – Lightweight Concrete Water Content [Addition]

All coarse lightweight aggregate used in a concrete mixture must be saturated surface dry prior to mixing. The total allowable water in the concrete mixture must account for the water in the aggregate and admixtures. The water-to-cementitious materials ratio must not exceed 0.50.

2-7.2 Section 1903 – SPECIFICATIONS FOR TESTS AND MATERIALS.

1903.5 – Additively Constructed Concrete (3D Printed Concrete) [Addition]

Pursuant to UFC 1-200-01 Section 104.11, Concrete produced using additive construction, hereafter referred to as Additively Constructed Concrete (ACC), is allowed as an alternative material, design, and method of construction when adhering to the following requirements and when approved in writing by the AHJ.

ACC structures are limited to one story, risk category I or II structures in seismic design categories A & B only. Additionally, the following general requirements or limitations apply:

- Unreinforced concrete construction is not allowed
- ACC elements are not allowed as part of the Lateral Force Resisting System (LFRS) in Seismic Design Category B, unless LFRS assemblies have been shake table-tested with relevant loading, or wind loads can be demonstrated to govern over seismic loads using an R-factor of 1.0.
- Provide a full description of concrete mixes, including how mixes will differ from region to region as applicable. Include admixtures in description

where utilized.

- Provide a narrative description of Quality Assurance and Quality Control procedures for concrete placement, including hot and cold weather placement constraints for ACC elements if applicable
- Maintain minimum reinforcing cover per ACI 318. Cover shall not consist of printed materials, unless demonstrated through testing that ACI 318 development length can be met using applicable load factors.
- Cast-in-place or post-installed anchors must not depend on printed material for shear or tensile strength, unless site tested to 150% of design load.
- Diaphragm-to-wall connections must be shown by calculation or testing to resist in-plane and out-of-plane forces with applicable load factors. Anchorage may not be solely dependent on printed shell material.
- Provide complete design drawings, including connection detailing sufficient to adequately convey continuous vertical and lateral load path to foundation
- Provide complete mathematical demand and capacity calculations based on ACI 318 for all applicable ASCE 7 loads and affected elements. Calculations must demonstrate a complete vertical and lateral load path and may not rely on printed shell elements to resist loads except for pure compression. Alternatively, webbing may be employed with shell elements as indicated in the following image, but only with third-party load-testing validation of composite assemblies for all relevant loading. Load capacity values must be published as part of a third party testing report and tested assemblies must be applicable to constructed assemblies.

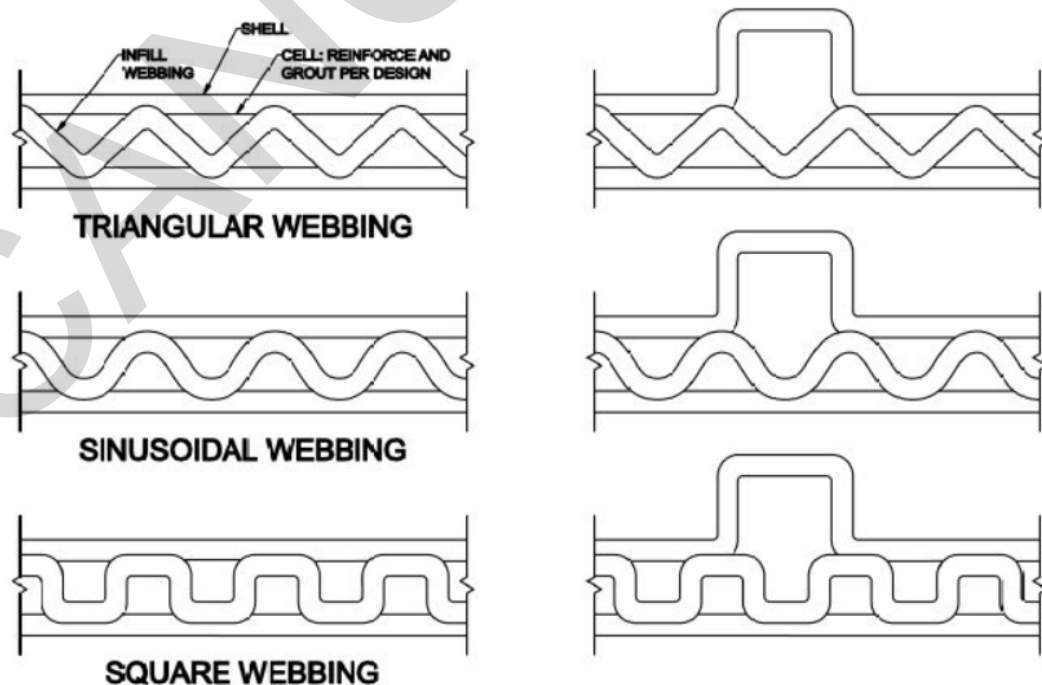

- Design must be peer reviewed by the government a minimum of 90 days

prior to construction start and will include review by subject matter experts at United States Army Corps of Engineers (USACE) Construction Engineering Research Laboratory (CERL). All comments and concerns must be resolved to the government's satisfaction.

Allowable ACC Elements and Limitations

- ACC is limited to reinforced walls no taller than 10 feet, reinforced embedded wall pilasters and non-participating stay-in-place formwork for simple reinforced continuous wall footings.
- Suspended elements, including but not limited to beams, girders, or floor and roof diaphragm elements are not approved for ACC.
- ACC wall elements must consist of two printed concrete face shells acting as stay-in-place forms with a minimum interior core width of 4 inches and a maximum core width of 12 inches. Provide print stabilizers spanning between face shells to occur at no greater than 12 inches on center horizontally and 6 inches on center vertically. Provide corner stabilizers spanning from interior wall corners to exterior face shell in both directions (e.g. either side of interior corner). Larger print stabilizer spacing require print-stability testing.
- Embedded pilasters must consist of printed shells and interior monolithic reinforced cast concrete cores that are 6 to 8 inches by 6 to 8 inches. Larger sections require print-stability testing.
- Wall cavities adjacent to pilasters that are without webbing or monolithic cast concrete shall not be permitted unless this portion is considered to be non-structural.

Third Party Independent Testing Requirements

ACC structures must conform to the requirements noted in this section and ICC AC509 - 3D Automated Construction Technology for 3D Concrete Walls. If AC 509 is in conflict, this UFC supersedes. Compliance to this section must be demonstrated by obtaining an ICC ES evaluation report (or equivalent) that conforms to both ICC-AC509 and the following modifications to ICC-AC509

ICC AC509 4.2.1 [Replacement] Cast Specimens for compressive testing shall be tested in accordance with ASTM C31 for monolithically cast portions of wall. Cast Specimens following ASTM C31 or ASTM C109 shall be permitted for printable material mixture development only. Prior to construction, conduct compressive strength testing in accordance with ASTM C109 with specimens extracted by saw cutting in accordance with ASTM C42 and prepared to meet planeness requirements according to ASTM C109. Specimens shall capture at least one interface and shall be tested for compression in the directions parallel to print direction, perpendicular to print direction, and transverse to print direction.

ICC AC509 4.2.2 [Replacement] Prior to specimen creation, the flow of the

printable material shall be tested in accordance with ASTM C230. For materials that exhibit slump prior to entering the printer the mix may be tested in accordance with ASTM C143 or C1611. Printable materials shall be tested in accordance to ASTM C230 prior to placement and within 5 minutes after leaving the printer.

ICC AC509 4.2.4 [Replacement] Unconfined compression Strength (UCS) Testing: Shall be performed in accordance with ASTM 2166, with cylindrical specimen sizes representative of the bead geometry, where the diameter or height of the specimen must be at least 5 times the maximum particle size. Prior to construction the UCS shall be performed at 0, 15, 30, 45, 60, 90, and 120 minutes after mixing and the elastic limit at each age shall be determined. This shall be used to report the time to next layer limit based on weight of successive layers expected. Printable materials shall be tested in accordance with this test method prior to placement during printing and within 5 minutes of leaving the printer.

ICC AC509 4.3.3 [Supplement] Freeze-Thaw specimens of printed materials shall be extracted from printed components through saw cutting in accordance with ASTM C666. Specimen sizes shall be as described in ASTM C666 to include specimens with at least 1 interface on each side parallel to the length of the specimen and specimens with at least 3 layers perpendicular to the length of the specimen. For regions where freeze-thaw is not a concern this test may be forgone.

ICC AC509 4.4.1 [Replacement] Perform tests on 3D printed specimens in accordance with ASTM C341. Length change specimens of printed materials shall be extracted from printed components. Specimens shall have at least 1 interface on each side parallel to the length of the specimen. Components that will be in contact with soils with high sulfate content or exposed to salts must be tested according to ASTM C1012.

ICC AC509 4.6.2 [Addition] Tensile bond strength shall be in accordance with ASTM C496 or ASTM C1583. Shear bond strength shall be tested as described below.

- 4.6.2.1 Tensile bond strength tested in accordance with ASTM C496 shall use prismatic specimens consisting of at least two layers with a single interface loaded along the interface. Specimens shall be tested transverse to the print with the height being equal to a single shell width, and the height being equal to two times a single shell width, and the length being equal to at least 3 times a single shell width.
- 4.6.2.2 Direct shear testing shall be loaded in single or double shear using prismatic specimens consisting of at least two layers for single shear and three layers for double shear. Specimens shall have dimensions that are representative of the wall shell dimensions

and a length of at least 3 times the shell width. Loading rate shall in accordance to ASTM C496.

- 4.6.2.3 Specimens for interface testing shall be extracted by saw cutting in accordance with ASTM C42 and prepared to meet planeness requirements in ASTM C109.

ICC AC509 4.8 [Addition] For construction geometries, a print stability test must be performed, which consists of a print mock-up representative of the wall geometry used in construction to ensure that there are no stability issues prior to construction. Time between layers and construction shall be represented of field conditions. This is permitted to be done as part of the development of structural test samples.

ICC AC509 4.9 [Addition] Dynamic Testing

- 4.9.1 Testing for blast overpressure, where applicable, must be in accordance with ASTM F2247 or ASTM F2927 for door locations and ASTM F1642 or GSA TS01 for windows locations. Ballistics testing must be in accordance with MIL STD 662.
- 4.9.2 For compliance for wind and seismic, testing shall be performed in accordance with ASTM E2126 procedure for in-plane shear or out-of-plane bending. Where structures must meet seismic categories higher than C, shake-table testing shall be performed to meet design requirements.
- 4.9.3 Impact: ASTM E1886 for windborne debris and ASTM E695 for impact loading.
- 4.9.4 Blast: Tested for overpressure in accordance with ASTM F2247 or ASTM F2927 for door locations and ASTM F1642 or GSA TS01 for windows locations.
- 4.9.5 Ballistics: Testing shall be in accordance to MIL STD 662.

ICC AC509 5.5 [Replacement] Special Inspections shall be performed in accordance with this UFC. Quality control testing shall be performed by obtaining samples cured following ASTM C31 for compression testing and interface testing shall be performed according to section 4.2 and 4.6. Fresh material testing shall be performed in accordance with ASTM C31 with testing performed in accordance with section 4.2.2 and 4.2.4 in replace of the slump test.

5.5.1 Representative components for sample extraction shall be printed at the same time as construction of the printed components to be placed in service. Each representative components shall be large enough to extract samples for compliance with sections 4.2.1, 4.4.1, and 4.6.2.

5.5.2 Data on printing conditions and process shall be documented and reported to include: start times, print time for each layer, delay times (includes waiting between layers), reasons for delays, time that delay occurred, and hourly temperature and humidity. If delay occurs in the middle

of printing a layer the time prior to delay and following delay should be recorded, in addition to the delay./1/

2-7.3 Section 1904 - DURABILITY REQUIREMENTS.

1904.3 - Environmental Severity Classification and Concrete Cover [Addition]

Conform to ACI 357.3R Table 5.5.4 for minimum concrete cover for exterior exposed concrete at project locations with an Environmental Severity Classification (ESC) C3 thru C5. See UFC 1-200-01 for determination of ESC for project locations. Exposed concrete is any concrete that is not enclosed within a building envelope. In addition, concrete with a minimum of two coats of exterior grade paint is not considered exposed where properly maintained. Corrosion inhibitor coatings/additives would not qualify as a paint coating. This requirement does not apply to galvanized, stainless or epoxy coated reinforcing. Refer to ACI 318 cover requirements in these cases.

2-7.4 Section 1907 - MINIMUM SLAB PROVISIONS.

1907.1 - General [Replacement]

Replace the first line of the paragraph to read:

The thickness of concrete floor slabs supported directly on the ground must not be less than 4 inches (102 mm).

1907.2 - Slab-on-Ground Design [Addition]

Design slabs-on-ground in accordance with ACI 360R, except slabs-on-ground supporting aircraft loading must be designed in accordance with UFC 3-260-02. Warehouses must have minimum reinforcing according to UFC 04-440-01.

1907.2.1 - Wall Loads on Slab-on-Ground [Addition]

Slabs-on-ground must have adequate thickness to support wall line loads, which can be determined through engineering analysis or from Tables 2-4 and 2-5. The thickened portion of a slab on ground must have a minimum width as shown in Figure 2-1. This does not apply to non-load bearing light gauge metal or wood partition walls.

1907.2.2 - Slab-on-Ground Over Permafrost [Addition]

Design and construction of slabs-on-ground over permafrost must be in accordance with UFC 3-130-01.

1907.2.3 - Post-Tensioned Slab-on-Ground [Addition]

The design of post-tensioned slabs-on-ground must be in accordance with PTI DC10.1.

Table 2-3 Maximum Allowable Wall Load at a Thickened Slab for Wall Load Near Center of Slab or Near Keyed or Doweled joints

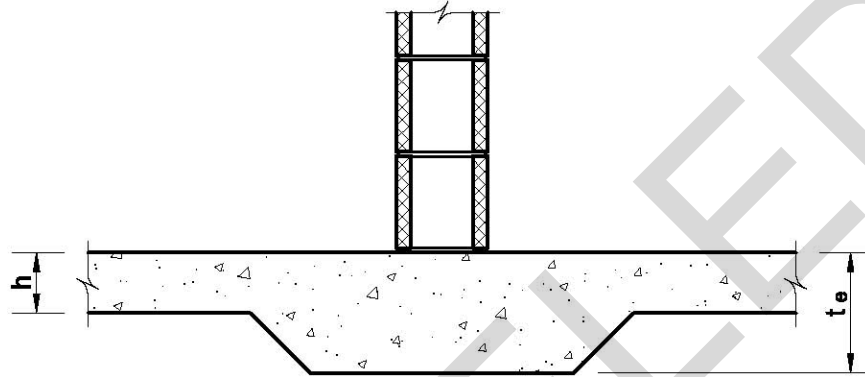

Thickness of Thickened Floor Slab, t_e	Slab Line Load Capacity, P			
	Flexural Strength ^a of Concrete			
	550 psi (3.9 MPa)	600 psi (4.1 MPa)	650 psi (4.5 MPa)	700 psi (4.8 MPa)
4 in (102 mm)	425 lb/ft (6.2 kN/m)	455 lb/ft (6.6 kN/m)	485 lb/ft (7.1 kN/m)	510 lb/ft (7.4 kN/m)
5 in (127 mm)	565 lb/ft (8.2 kN/m)	600 lb/ft (8.8 kN/m)	640 lb/ft (9.3 kN/m)	675 lb/ft (9.9 kN/m)
6 in (152 mm)	710 lb/ft (10.4 kN/m)	755 lb/ft (11.0 kN/m)	805 lb/ft (11.7 kN/m)	850 lb/ft (12.4 kN/m)
7 in (178 mm)	860 lb/ft (12.6 kN/m)	920 lb/ft (13.4 kN/m)	975 lb/ft (14.2 kN/m)	1030 lb/ft (15.0 kN/m)
8 in (203 mm)	1015 lb/ft (14.8 kN/m)	1080 lb/ft (15.8 kN/m)	1150 lb/ft (16.8 kN/m)	1215 lb/ft (17.7 kN/m)
9 in (229 mm)	1175 lb/ft (17.1 kN/m)	1255 lb/ft (18.3 kN/m)	1330 lb/ft (19.4 kN/m)	1410 lb/ft (20.6 kN/m)
10 in (254 mm)	1340 lb/ft (19.6 kN/m)	1430 lb/ft (20.9 kN/m)	1520 lb/ft (22.2 kN/m)	1605 lb/ft (23.4 kN/m)

Table 2-4 Maximum Allowable Wall Load at a Thickened Slab for Wall Load Near Free Edge

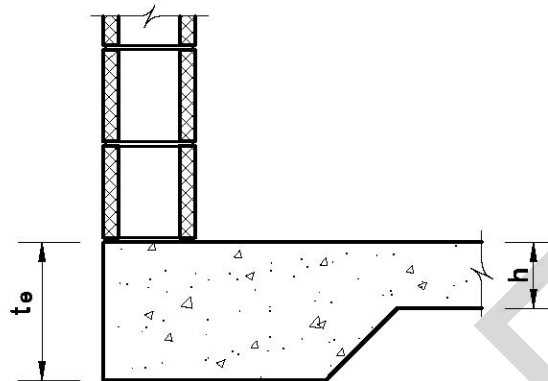

Thickness of Thickened Floor Slab, t_e	Slab Line Load Capacity, P			
	Flexural Strength ^a of Concrete			
	550 psi (3.9 MPa)	600 psi (4.1 MPa)	650 psi (4.5 MPa)	700 psi (4.8 MPa)
4 in (102 mm)	330 lb/ft (4.8 kN/m)	355 lb/ft (5.2 kN/m)	375 lb/ft (5.5 kN/m)	395 lb/ft (5.8 kN/m)
5 in (127 mm)	435 lb/ft (6.4 kN/m)	465 lb/ft (6.8 kN/m)	495 lb/ft (7.2 kN/m)	525 lb/ft (7.7 kN/m)
6 in (152 mm)	550 lb/ft (8.0 kN/m)	585 lb/ft (8.5 kN/m)	620 lb/ft (9.1 kN/m)	660 lb/ft (9.6 kN/m)
7 in (178 mm)	665 lb/ft (9.7 kN/m)	710 lb/ft (10.4 kN/m)	755 lb/ft (11.0 kN/m)	800 lb/ft (11.7 kN/m)
8 in (203 mm)	785 lb/ft (11.5 kN/m)	840 lb/ft (12.3 kN/m)	890 lb/ft (13.0 kN/m)	945 lb/ft (13.8 kN/m)
9 in (229 mm)	910 lb/ft (13.3 kN/m)	975 lb/ft (14.2 kN/m)	1035 lb/ft (15.1 kN/m)	1090 lb/ft (15.9 kN/m)
10 in (254 mm)	1040 lb/ft (15.2 kN/m)	1110 lb/ft (16.2 kN/m)	1180 lb/ft (17.2 kN/m)	1245 lb/ft (18.2 kN/m)

Notes for Table 2-4 and Table 2-5: The allowable wall loads are based on a modulus of subgrade reaction (k) of 100 pounds per cubic inch (27.1 MPa/m). The thickness of the thickened slab will be computed by multiplying the above thickness by a constant factor. Constants for other subgrade moduli are tabulated below.

Modulus of Sub-grade Reaction (k)	25 pci (6.8 MPa/m)	50 pci (13.6 MPa/m)	100 pci (27.1 MPa/m)	200 pci (54.3 MPa/m)	300 pci (81.4 MPa/m)
Constant Factor	1.3	1.1	1.0	0.9	0.8

For other modulus of subgrade reaction values, the constant values may be considered equal to $\sqrt[5]{100/k}$, ($\sqrt[5]{27.1/k}$ metric).

^a For this application, the flexural strength of concrete was assumed equal to $9\sqrt{f'_c}$, ($0.75\sqrt{f'_c}$ metric) where f'_c is the specified compressive strength of concrete in pounds per square inch (MPa).

CANCELLED

Table 2-1 Widths of Thickened Slabs and Slab Edge Conditions under Wall Loads

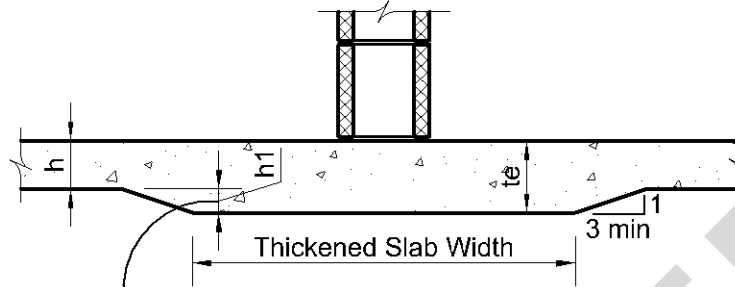

- 2"(51mm) - 3'-0"(914mm) Thickened Slab Width
- 3"(76mm) - 4'-0"(1219mm) Thickened Slab Width
- 4"(102mm) - 5'-0"(1524mm) Thickened Slab Width
- 5"(127mm) - 6'-0"(1828mm) Thickened Slab Width

A) SLABS LOADED NEAR THE CENTER

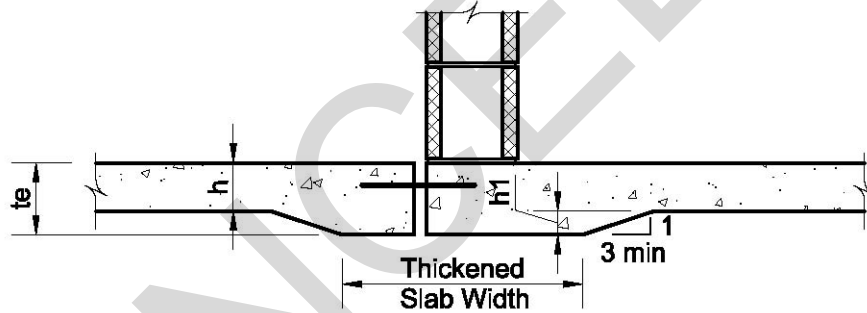

See Figure 2-1 (A) for slab width

B) SLABS LOADED NEAR A KEYED OR DOWELED JOINT

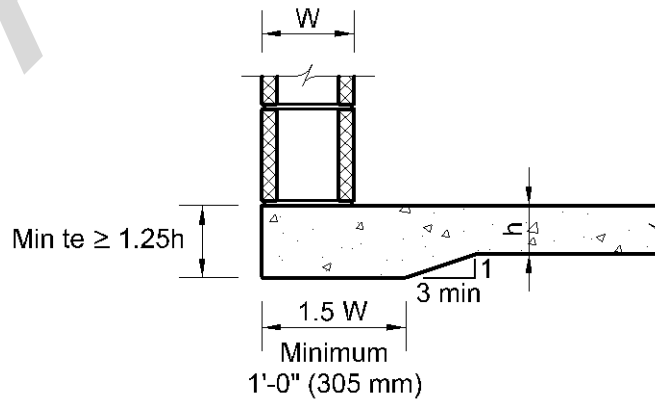

C) SLABS LOADED NEAR A FREE EDGE

2-8 IBC CHAPTER 21 – MASONRY.

2-8.1 Section 2101 – GENERAL.

Renumber Section 2101.2.1 to 2101.2.4.

2101.2.1 - Allowable Stress Design [Addition]

Masonry must be designed as reinforced unless the element is isolated from the structure so that vertical and lateral forces are not imparted to the element.

2101.2.2 - Strength Design [Addition]

Masonry must be designed as reinforced unless the element is isolated from the structure so that vertical and lateral forces are not imparted to the element.

2101.2.3 - Empirical Design [Addition]

Do not design Masonry according to the empirical method.

2101.4 - Shear Wall Construction [Addition]

Shear walls must be running bond construction only; stack bond construction is not permitted.

2-8.2 Section 2104 – CONSTRUCTION.

Renumber Sections 2104.1.1 and 2104.1.2 as 2104.1.4 and 2104.1.5, respectively.

2104.1.1 - Placing Mortar and Units [Addition]

Masonry walls below grade and elevator shaft walls must be grouted solid.

2104.1.2 - Installation of Wall Ties [Addition]

Use of corrugated metal brick ties is not permitted.

2104.1.3 - Joint Reinforcement [Addition]

Horizontal wall reinforcement must be continuous around wall corners and through wall intersections, unless the intersecting walls are separated. Reinforcement that is spliced in accordance with the applicable provisions of TMS 402-16 is permitted to be considered continuous.

2104.1.6 - Concrete Masonry Control Joints [Addition]

Spacing and placement of control joints must be in accordance with NCMA TEK 10-2C or 10-3.

2104.1.7 - Vertical Brick Expansion Joints [Addition]

Spacing, placement, and size of vertical brick expansion joints must be in accordance with BIA Technical Notes 18 and 18A.

2-8.3 Section 2106 - SEISMIC DESIGN.

2106.2 - Additional Requirements for Masonry Systems [Addition]

2106.2.1 - Minimum Reinforcement for Special or Intermediate Masonry Walls, SDC B-F [Addition]

In addition to the minimum reinforcement requirements of Sections 7.3.2.5 and 7.3.2.6 of TMS 402-16, the following applies:

1. Reinforcement is required be continuous around wall corners and through wall intersections, unless the intersecting walls are separated. Reinforcement that is spliced in accordance with applicable provisions of TMS 402-16 is permitted be considered continuous.
2. Only horizontal reinforcement that is continuous in the wall or element is permitted to be included in computing the area of horizontal reinforcement. Intermediate bond beam steel properly designed at control joints is permitted be considered continuous.

2106.2.2 - Joints in Structures assigned to SDC B or Higher [Addition]

Where concrete abuts structural masonry and the joint between the materials is not designed as a separation joint, the concrete must be roughened so that the average height of aggregate exposure is 1/8 in. (3 mm) and must be bonded to the masonry in accordance with these requirements as if it were masonry. Vertical joints not intended to act as separation joints are required to be crossed by horizontal reinforcement as required by Section 5.1.1.2 of TMS 402-16.

2106.2.3 - Coupling Beams in Structures Assigned to SDC D or Higher [Addition]

Structural members that provide coupling between shear walls must be designed to reach their moment or shear nominal strength before either shear wall reaches its moment or shear nominal strength. Analysis of coupled shear walls must comply with accepted principles of mechanics.

The design shear strength, ϕV_n , of the coupling beams is required to satisfy the following criterion:

$$\phi V_n \geq \frac{1.25(M_1 + M_2)}{L_c} + 1.4V_g$$

Where:

M_1 and M_2 = nominal moment strength at the ends of the beam

L_c = length of the beam between the shear walls

V_g = unfactored shear force due to gravity loads

The calculation of the nominal flexural moment needs to include the reinforcement in reinforced concrete roof and floor systems. The width of the reinforced concrete slab used for calculations of reinforcement must be six times the floor or roof slab thickness.

2106.2.4 - Anchoring to Masonry [Addition]

Anchors in masonry must be designed in accordance with TMS 402-16. Additionally, at least one of the following must be satisfied for structures assigned to SDC C or higher.

- a. Anchors in tension are designed to be governed by the tensile strength of a ductile steel element.
- b. Anchors are designed for the maximum load that can be transmitted to the anchors from a ductile attachment, considering both material overstrength and strain hardening of the attachment.
- c. Anchors are designed for the maximum load that can be transmitted to the anchors by a non-yielding attachment.
- d. Anchors are designed for the maximum load obtained from design load combinations that include E , where the effect of horizontal ground motion, Q_E , is multiplied by Ω_0 .

[C] 2106.2.4 - Anchoring to Masonry [Addition]

This [Addition] harmonizes design of anchors embedded in masonry with those embedded in concrete. These provisions are intended to prevent brittle failure in the connections. ACI 318-14 Chapter 17 includes similar provisions to prevent brittle failure in anchors in concrete. These requirements are simplified version of those in ACI 318-14. Note Option a is available only for anchors in tension, and not for anchors in shear. Also, Item d requires that the anchor design forces produced by the horizontal ground motions only (Q_E) be multiplied by the overstrength factor Ω_0 . Anchor design forces produced by the vertical earthquake ground motions (E_v) do not need to be amplified.

2-8.4 **Section 2109 - EMPIRICAL DESIGN OF MASONRY [Deletion].**

Delete this section in its entirety.

2-9 IBC CHAPTER 22 – STEEL.

2-9.1 **Section 2204 – CONNECTIONS.**

2204.2 – Bolting [Supplement]

Add the following to the end of the paragraph:

Compressible-washer-type direct tension indicators or twist-off-type tension-control bolts conforming to RCSC, *Specification for Structural Joints Using High-Strength Bolts* must be provided at all high strength bolted connections.

2-9.2 **Section 2205 - STRUCTURAL STEEL.**

2205.1 – General [Supplement]

Add the following to the end of the paragraph:

Design structural steel floor framing systems for vibration serviceability in accordance with AISC Design Guide 11.

2205.3 – Steel Structures in Corrosive Environments [Addition]

Protect exposed exterior steel in high humidity environments with hot dipped galvanizing or the use of stainless alloy. Coatings may be used in other environments. Select the appropriate system or material to suit the anticipated exposure. For exposed exterior steel deck and cold-formed steel members, provide ASTM A653/A653M G90 galvanizing and connect with corrosion-resistant fasteners. See Section B-5.4 of UFC 3-301-01 for additional guidance.

2-9.3 **Section 2210 - COLD-FORMED STEEL.**

2210.1.1.2 – Steel Roof Deck [Supplement]

Add the following to the end of the paragraph:

Steel roof deck is not permitted to be thinner than 22-gauge.

2210.1.1.4 – Steel Deck Diaphragms [Addition]

Design steel deck diaphragms for in-plane and out-of-plane loads in accordance with SDI DDM03.

2-9.4 **Section 2211 - COLD-FORMED STEEL LIGHT-FRAMED CONSTRUCTION.**

2211.1.1 - Seismic Requirements for Cold-Formed Steel Structural Systems [Replacement]

Design cold-formed steel light-frame construction to resist seismic forces in accordance with the provisions of Section 2211.1.1.1, and Section 2211.1.1.2 or Section 2211.1.1.3.

Renumber Sections 2211.1.1.1 and 2211.1.1.2 as 2211.1.1.2 and 2211.1.1.3, respectively.

2211.1.1.1 – Diagonal Bracing Material [Addition]

For diagonal bracing, use ASTM A653/A653M steel without rerolling.

[C] 2211.1.1.1 - Diagonal Bracing Material [Addition]

Rerolling induces strain hardening and reduces the elongation of the material and is therefore not desirable for performance under seismic loading.

2211.3 – Floor Vibrations [Addition]

Design cold-formed steel framing systems for vibration serviceability in accordance with the proposed design procedure in *Floor Vibration Design Criterion for Cold-Formed C-Shaped Supported Residential Floor Systems* by Kraus. The proposed design procedure is based on residential construction, but is suitable for most applications of cold-formed floor construction.

2211.4 – Brick Veneer/Steel Stud Walls [Addition]

Follow the recommendations of BIA Technical Note 28B for the Design of steel stud backup for brick veneer. In particular, recommendations for minimum stud gage, minimum galvanization, minimum anchorage of studs to track, welding of studs, use of deflection track, allowable stud deflection, wall sheathing, and water-resistant barriers.

2211.5 – Cold-Formed Steel Connections [Addition]

Interconnect cold-formed steel members with screw fasteners or by welding. The use of pneumatic nailing is permitted only for the connection of cold-formed steel members to members made of other materials.

2211.6 – Galvanized Cold-Formed Framing [Addition]

Cold-formed steel members exposed to spray from salt, salt water, brackish water, or seawater must be galvanized per ASTM A653/A653M G90 and all fasteners must be hot dipped galvanized or stainless steel.

2-10 IBC CHAPTER 23 – WOOD.

2-10.1 Section 2308 - CONVENTIONAL LIGHT-FRAME CONSTRUCTION.

2308.2.6 – Risk category limitation [Replacement]

The use of the provisions for *conventional light-frame construction* in this section is not permitted for RC IV buildings assigned to *Seismic Design Category C, D, E, or F*, as determined in 2018 IBC Section 1613.2.5.

CANCELLED

CHAPTER 3 MODIFICATIONS TO ASCE 7

3-1 ASCE 7-16 CHAPTER 1 – GENERAL.

3-1.1 Section 1.3 - BASIC REQUIREMENTS.

1.3.1 – Strength and Stiffness [Supplement]

Add to the end of Item c.: During the design concept stage of development, documentation must be submitted to the AHJ for approval of the performance based design approach.

1.3.1.3 – Performance Based Procedures [Replacement]

Structural and nonstructural components and their connections must be demonstrated by a combination of analysis and testing to provide a reliability not less than that expected for similar components designed in accordance with the Strength Procedures of Section 1.3.1.1 when subject to the influence of dead, live, environmental, and other loads. Consideration must be given to uncertainties in loading and resistance.

1.3.1.3.3 – Documentation [Replacement]

Provide reports submitted for approval to the AHJ and to an independent peer reviewer (where required), that document compliance with this section and the results of analysis and testing.

3-2 ASCE 7-16 CHAPTER 2 – COMBINATIONS OF LOADS.

3-2.1 Section 2.3 - LOAD COMBINATIONS FOR STRENGTH DESIGN.

2.3.4 – Load Combinations Including Self-Straining Forces and Effects [Supplement]

Add to the end of the paragraph: The effect of load T needs to be taken into consideration on a structure. For further information see ASCE 7 Section C2.3.4.

[C] 2.3.4 Load Combinations Including Self-Straining Forces and Effects [Supplement]

ASCE 7-16 Section 2.3.4 does not provide specific load factors to use with T . Commentary Section C.2.3.4 contains such load factors. The entire text of the commentary should be read and understood before using the load combinations in the commentary. The impact of T on serviceability and long term performance of the facility may also need to be evaluated.

3-2.2 **Section 2.4 – LOAD COMBINATIONS FOR ALLOWABLE STRESS DESIGN.**

2.4.4 – Load Combinations Including Self-Straining Forces and Effects [Supplement]

Add to the end of the paragraph: The effect of load T needs to be taken into consideration on a structure. For further information, see ASCE 7 Section C2.4.4.

[C] 2.4.4 Load Combinations Including Self-Straining Forces and Effects [Supplement]

ASCE 7-16 Section 2.4.4 does not provide specific load factors to use with T . Commentary Section C.2.4.4 contains such load factors. The entire text of the commentary should be read and understood before using the load combinations in the commentary. The impact of T on serviceability and long term performance of the facility may also need to be evaluated.

3-2.3 **Section 2.5 - LOAD COMBINATIONS FOR EXTRAORDINARY EVENTS.**

2.5.1 – Applicability [Replacement]

Where required by UFC 4-023-03, strength and stability must be checked to ensure that structures are capable of resisting the effects of progressive collapse with the load combinations provided in UFC 4-023-03.

2.5.2 – Load Combinations [Deletion]

Delete this section in its entirety.

2.5.3 – Stability Requirements [Deletion]

Delete this section in its entirety.

3-3 ASCE 7-16 CHAPTER 6 – TSUNAMI LOADS.

3-3.1 **Section 6.14 TSUNAMI VERTICAL EVACUATION REFUGE STRUCTURES**

6.14.1 - Minimum Inundation Elevation and Depth [Supplement]

Where a factor of 1.3 is required to be multiplied by the maximum considered tsunami inundation elevation, this factor need not be applied to the sea-level rise component of maximum considered inundation elevation. Where a 1.3 factor is required, it is not cumulative to the Tsunami factor in Table 2-2, but rather supplants the tsunami factor in Table 2-2.

3-3.2 Section 6.15 DESIGNATED NONSTRUCTURAL COMPONENTS AND SYSTEMS

6.15.1 – Performance Requirements [Supplement]

Design mission-critical systems according to the requirements of 6.15.1. In addition to projected sea-level rise (see table 2-2), mission critical systems must be situated above maximum inundation elevation factored up by 1.3, unless designed directly for tsunami effects and if inundation would not inhibit critical function during and after a tsunami.

3-3.3 Section 6.5 ANALYSIS OF DESIGN INUNDATION DEPTH AND FLOW VELOCITY

6.5.3 – Sea Level Change [Supplement]

Subject to approval by the AHJ, a medium 2065 DoD Regional Sea Level Rise (DRSL) target may be utilized for risk category IV and V structures in tsunami prone regions when designing for a combination of tsunami and sea-level rise. Design must incorporate future construction adaptation to either the High 2065 or Highest 2065 DRSL scenarios according to Table 2-2 for RC IV and V structures. Cost and risk must be considered when selecting adaptive design features. The adaptive design features must be included in the design analysis and in the design drawings and should be labeled, “Not in Contract (NIC),” to permit future construction as needed with negligible additional design cost or effort. The DRSL database is available at:

<https://sealevelscenarios.serdp-estcp.org /1/>

3-4 ASCE 7-16 CHAPTER 7 – SNOW LOADS.

3-4.1 Section 7.4 – Sloped Roof Snow Loads, p_s [Supplement].

Add to the end of the paragraph: Where obstructions occur on the roof from equipment such as photovoltaic panels, lightning cable systems, etc., the potential for snow buildup around the obstructions needs to be considered.

3-5 ASCE 7-16 CHAPTER 11 – SEISMIC DESIGN CRITERIA.

3-5.1 Section 11.1 – GENERAL.

11.1.2 – Scope [Supplement]

The design and detailing of the components of the seismic force-resisting system must comply with the applicable provisions of ASCE 7-16 Section 11.7 and ASCE 7-16 Chapter 12, as modified by this UFC and 3-301-02 (for RC V structures), in addition to the nonseismic requirements of the 2018 IBC.

11.1.3 – Applicability [Supplement]

Add the following at the end of the section: Building or structures that are not routinely occupied, but whose primary purpose supports human activities, such as training towers, are not to be classified as non-building structures unless specifically approved by the AHJ.

3-5.2 Section 11.2 – DEFINITIONS.

DESIGNATED SEISMIC SYSTEMS [Replacement]

Those nonstructural components that require design in accordance with Chapter 13 and for which the component importance factor, I_p , is greater than 1.0. This designation applies to systems that are required to be operational following the Design Earthquake. Designated Seismic Systems will be identified by Owner and will have an Importance Factor $I_p = 1.5$.

FRAME:

Moment Frame [Replacement]

A frame in which members and joints resist lateral forces by flexure as well as along the axis of the members. Moment frames are categorized as intermediate moment frames (IMF), ordinary moment frames (OMF), and special moment frames (SMF). Every joint must be restrained against rotation.

3-5.3 Section 11.5 - IMPORTANCE FACTOR AND RISK CATEGORY.

11.5.1 Importance Factor [Replacement]

A seismic importance factor, I_e , must be assigned to each structure in accordance with Table 2-2 of this UFC.

3-6 ASCE 7-16 CHAPTER 12 – SEISMIC DESIGN REQUIREMENTS FOR BUILDING STRUCTURES.

3-6.1 Section 12.2 – STRUCTURAL SYSTEM SELECTION.

12.2.1 - Selection and Limitations [Supplement]

Table 3-1, Replacement for ASCE 7-16 Table 12.2-1, must be used in lieu of ASCE 7-16 Table 12.2-1.

3-6.2 **Section 12.6 - ANALYSIS PROCEDURE SELECTION [Supplement].**

Add at the end of the section:

For RC IV structures designed using the alternate procedure of Appendix C of this publication, only nonlinear static or nonlinear response history procedure in accordance with the provisions of Appendix C is permitted

3-6.3 **Section 12.8 - EQUIVALENT LATERAL FORCE PROCEDURE [Supplement].**

When the ELF procedure is used, provisions of ASCE 7-16 Section 12.8 must be used. This procedure may be applied to the design of buildings assigned to RCs I through IV as permitted by ASCE 7-16 Table 12.6-1.

[C] 12.8 EQUIVALENT LATERAL FORCE PROCEDURE [Supplement]

The ELF procedure is the primary design method for seismic design of military buildings. Several restrictions on using the ELF procedure for buildings in SDCs D - F are imposed by ASCE 7-16 Table 12.6-1. These restrictions are predicated on the presence of horizontal and vertical irregularities. The Simplified Design Procedure of ASCE 7-16 Section 12.14 is a simplification of the ELF procedure that may be applied to low-rise buildings that meet a set of pre-conditions given in ASCE 7-16 Section 12.14.1.1. Some of the pre-conditions are onerous to the point of rendering the simplified design procedure of Section 12.14 less than useful.

**Table 3-1, Replacement for ASCE 7-16 Table 12.2-1,
Design Coefficients and Factors for Basic Seismic Force-Resisting Systems**

BASIC SEISMIC FORCE-RESISTING SYSTEM	DETAILING REFERENCE SECTION	RESPONSE MODIFICATION COEFFICIENT R^a	OVERSTRENGTH FACTOR, Ω_0^b	DEFLECTION AMPLIFICATION FACTOR, C_d^c	STRUCTURAL SYSTEM LIMITATIONS INCLUDING STRUCTURAL HEIGHT, h_m , (FEET) LIMITS BY SEISMIC DESIGN CATEGORY ^d				
					B	C	D ^e	E ^e	F ^f
A. Bearing Wall Systems									
1. Special reinforced concrete shear walls ^{g,h}	(18.2.1.6) ^s	5	2-1/2	5	NL	NL	160	160	100
2. Ordinary reinforced concrete shear walls ^g	(18.2.1.6) ^s	4	2-1/2	4	NL	NL	NP	NP	NP
3. Detailed plain concrete shear walls ^g	(1905.1.6) ^u	2	2-1/2	2	NL	NP	NP	NP	NP
4. Ordinary plain concrete shear walls ^g	(Chapter 14) ^s	1-1/2	2-1/2	1-1/2	NL	NP	NP	NP	NP
5. Intermediate precast shear walls ^g	(18.2.1.6) ^s , (1905.1.3) ^u	4	2-1/2	4	NL	NL	40 ⁱ	40 ⁱ	40 ⁱ
6. Ordinary precast shear walls ^g	(Chapter 11) ^s	3	2-1/2	3	NL	NP	NP	NP	NP
7. Special reinforced masonry shear walls	(7.3.2.6) ^t	5	2-1/2	3-1/2	NL	NL	160	160	100
8. Intermediate reinforced masonry shear walls	(7.3.2.5) ^t	3-1/2	2-1/2	2-1/4	NL	NL	NP	NP	NP
9. Ordinary reinforced masonry shear walls	(7.3.2.4) ^t	2	2-1/2	1-3/4	NL	160	NP	NP	NP
10. Detailed plain masonry shear walls	This system is not permitted by UFC, but is permitted by ASCE 7-16 for SDC B								
11. Ordinary plain masonry shear walls	This system is not permitted by UFC, but is permitted by ASCE 7-16 for SDC B								
12. Prestressed masonry shear walls	(7.3.2.10, 7.3.2.11, 7.3.2.12) ^t	1-1/2	2-1/2	1-3/4	NL	NP	NP	NP	NP

**Table 3-1 (Continued) Replacement for ASCE 7-16 Table 12.2-1
Design Coefficients and Factors for Basic Seismic Force-Resisting Systems**

BASIC SEISMIC FORCE-RESISTING SYSTEM	DETAILING REFERENCE SECTION	RESPONSE MODIFICATION COEFFICIENT R^a	SYSTEM OVER-STRENGTH FACTOR, Ω_0^b	DEFLECTION AMPLIFICATION FACTOR, C_d^c	STRUCTURAL SYSTEM LIMITATIONS INCLUDING STRUCTURAL HEIGHT, h_n , (FEET) LIMITS BY SEISMIC DESIGN CATEGORY ^d				
					B	C	D ^e	E ^e	F ^f
13. Ordinary reinforced AAC masonry shear walls	(7.3.2.9) ^t	2	2-1/2	2	NL	35	NP	NP	NP
14. Ordinary plain AAC masonry shear walls	(7.3.2.7) ^t	1-1/2	2-1/2	1-1/2	NL	NP	NP	NP	NP
15. Light-frame (wood) walls sheathed with wood structural panels rated for shear resistance	(2301-2307) ^u	6-1/2	3	4	NL	NL	65	65	65
16. Light-frame (cold-formed steel) walls sheathed with wood structural panels rated for shear resistance or <i>with</i> steel sheets	(2211, 2301-2307) ^u	6-1/2	3	4	NL	NL	65	65	65
17. Light-frame walls with shear panels of all other materials	(2211, 2301-2307) ^u	2	2-1/2	2	NL	NL	35	NP	NP
18. Light-frame (cold-form steel) wall systems using flat strap bracing	(2211, 2301-2307) ^u	4	2	3-1/2	NL	NL	65	65	65
B. Building Frame Systems									
1. Steel eccentrically braced frames	(F3) ^r	8	2	4	NL	NL	160	160	100
2. Steel special concentrically braced frames	(F2) ^r	6	2	5	NL	NL	160	160	100
3. Steel ordinary concentrically braced frames	(F1) ^r	3-1/4	2	3-1/4	NL	NL	35 ^j	35 ^j	NP ^j
4. Special reinforced concrete shear walls ^{g,h}	(18.2.1.6) ^s	6	2-1/2	5	NL	NL	160	160	100

**Table 3-1 (Continued) Replacement for ASCE 7-16 Table 12.2-1
Design Coefficients and Factors for Basic Seismic Force-Resisting Systems**

BASIC SEISMIC FORCE-RESISTING SYSTEM	DETAILING REFERENCE SECTION	RESPONSE MODIFICATION COEFFICIENT R^a	SYSTEM OVER-STRENGTH FACTOR, Ω_0^b	DEFLECTION AMPLIFICATION FACTOR, C_d^c	STRUCTURAL SYSTEM LIMITATIONS INCLUDING STRUCTURAL HEIGHT, h_n , (FEET) LIMITS BY SEISMIC DESIGN CATEGORY ^d				
					B	C	D ^e	E ^e	F ^f
5. Ordinary reinforced concrete shear walls ^g	(18.2.1.6) ^s	5	2-1/2	4-1/2	NL	NL	NP	NP	NP
6. Detailed plain concrete shear walls ^g	(1905.1.6) ^u	2	2-1/2	2	NL	NP	NP	NP	NP
7. Ordinary plain concrete shear walls ^g	(Chapter 14) ^s	1-1/2	2-1/2	1-1/2	NL	NP	NP	NP	NP
8. Intermediate precast shear walls ^g	(18.2.1.6) ^s , (1905.1.3) ^u	5	2-1/2	4-1/2	NL	NL	40 ⁱ	40 ⁱ	40 ⁱ
9. Ordinary precast shear walls ^g	(Chapters 1 - 18) ^s	4	2-1/2	4	NL	NP	NP	NP	NP
10. Steel and concrete composite eccentrically braced frames	(H3) ^r	8	2	4	NL	NL	160	160	100
11. Steel and concrete composite special concentrically braced frames	(H2) ^r	5	2	4-1/2	NL	NL	160	160	100
12. Steel and concrete composite ordinary braced frames	(H1) ^r	3	2	3	NL	NL	NP	NP	NP
13. Steel and concrete composite plate shear walls	(H6) ^r	6-1/2	2-1/2	5-1/2	NL	NL	160	160	100
14. Steel and concrete composite special shear walls	(H5) ^r	6	2-1/2	5	NL	NL	160	160	100
15. Steel and concrete composite ordinary shear walls	(H4) ^r	5	2-1/2	4-1/2	NL	NL	NP	NP	NP
16. Special reinforced masonry shear walls	(7.3.2.6) ^t	5-1/2	2-1/2	4	NL	NL	160	160	100
17. Intermediate reinforced masonry shear walls	(7.3.2.5) ^t	4	2-1/2	4	NL	NL	NP	NP	NP
18. Ordinary reinforced masonry shear walls	(7.3.2.4) ^t	2	2-1/2	2	NL	160	NP	NP	NP

**Table 3-1 (Continued) Replacement for ASCE 7-16 Table 12.2-1
Design Coefficients and Factors for Basic Seismic Force-Resisting Systems**

BASIC SEISMIC FORCE-RESISTING SYSTEM	DETAILING REFERENCE SECTION	RESPONSE MODIFICATION COEFFICIENT R^a	SYSTEM OVER-STRENGTH FACTOR, Ω_0^b	DEFLECTION AMPLIFICATION FACTOR, C_d^c	STRUCTURAL SYSTEM LIMITATIONS INCLUDING STRUCTURAL HEIGHT, h_n , (FEET) LIMITS BY SEISMIC DESIGN CATEGORY ^d				
					B	C	D ^e	E ^e	F ^f
19. Detailed plain masonry shear walls	This system is not permitted by UFC, but is permitted by ASCE 7-16 for SDC B								
20. Ordinary plain masonry shear walls	This system is not permitted by UFC, but is permitted by ASCE 7-16 for SDC B								
21. Prestressed masonry shear walls	(7.3.2.10, 7.3.2.11, 7.3.2.12) ^t	1-1/2	2-1/2	1-3/4	NL	NP	NP	NP	NP
22. Light-frame (wood) walls sheathed with wood structural panels rated for shear resistance	(2301-2307) ^u	7	2-1/2	4-1/2	NL	NL	65	65	65
23. Light-frame (cold-formed steel) walls sheathed with wood structural panels rated for shear resistance or <i>with</i> steel sheets	(2211, 2301-2307) ^u	7	2-1/2	4-1/2	NL	NL	65	65	65
24. Light-framed walls with shear panels of all other materials	(2211, 2301-2307) ^u	2-1/2	2-1/2	2-1/2	NL	NL	35	NP	NP
25. Steel buckling-restrained braced frames	(F4) ^r	8	2-1/2	5	NL	NL	160	160	100
26. Steel special plate shear walls	(F5) ^r	7	2	6	NL	NL	160	160	100
C. Moment-Resisting Frame Systems									
1. Steel special moment frames	(E3) ^r	8	3	5-1/2	NL	NL	NL	NL	NL
2. Steel special truss moment frames	(E4) ^r	7	3	5-1/2	NL	NL	160	100	NP
3. Steel intermediate moment frames	(E2) ^r	4-1/2	3	4	NL	NL	35 ^k	NP ^k	NP ^k
4. Steel ordinary moment frames	(E1) ^r	3-1/2	3	3	NL	NL	NP ^{l,q}	NP ^{l,q}	NP ^{l,q}
5. Special reinforced concrete moment frames ^m	(18.2.1.6) ^s	8	3	5-1/2	NL	NL	NL	NL	NL

**Table 3-1 (Continued) Replacement for ASCE 7-16 Table 12.2-1
Design Coefficients and Factors for Basic Seismic Force-Resisting Systems**

BASIC SEISMIC FORCE-RESISTING SYSTEM	DETAILING REFERENCE SECTION	RESPONSE MODIFICATION COEFFICIENT R^a	SYSTEM OVER-STRENGTH FACTOR, Ω_0^b	DEFLECTION AMPLIFICATION FACTOR, C_d^c	STRUCTURAL SYSTEM LIMITATIONS INCLUDING STRUCTURAL HEIGHT, h_n , (FEET) LIMITS BY SEISMIC DESIGN CATEGORY ^d				
					B	C	D ^e	E ^e	F ^f
6. Intermediate reinforced concrete moment frames	(18.2.1.6) ^s	5	3	4-1/2	NL	NL	NP	NP	NP
7. Ordinary reinforced concrete moment frames	(18.2.1.6) ^s	3	3	2-1/2	NL	NP	NP	NP	NP
8. Steel and concrete composite special moment frames	(G3) ^r	8	3	5-1/2	NL	NL	NL	NL	NL
9. Steel and concrete composite intermediate moment frames	(G2) ^r	5	3	4-1/2	NL	NL	NP	NP	NP
10. Steel and concrete composite partially restrained moment frames	(G4) ^r	6	3	5-1/2	160	160	100	NP	NP
11. Steel and concrete composite ordinary moment frames	(G1) ^r	3	3	2-1/2	NL	NP	NP	NP	NP
12. Cold-formed steel—special bolted moment frame ⁿ	(2210) ^u	3-1/2	3 ^o	3-1/2	35	35	35	35	35
D. Dual Systems with Special Moment Frames Capable of Resisting at Least 25% of Prescribed Seismic Forces [ASCE 7-16 12.2.5.1]									
1. Steel eccentrically braced frames	(F3) ^r	8	2-1/2	4	NL	NL	NL	NL	NL
2. Steel special concentrically braced frames	(F2) ^r	7	2-1/2	5-1/2	NL	NL	NL	NL	NL
3. Special reinforced concrete shear walls ^{g,h}	(18.2.1.6) ^s	7	2-1/2	5-1/2	NL	NL	NL	NL	NL
4. Ordinary reinforced concrete shear walls ^g	(18.2.1.6) ^s	6	2-1/2	5	NL	NL	NP	NP	NP
5. Steel and concrete composite eccentrically braced frames	(H3) ^r	8	2-1/2	4	NL	NL	NL	NL	NL

**Table 3-1 (Continued) Replacement for ASCE 7-16 Table 12.2-1
Design Coefficients and Factors for Basic Seismic Force-Resisting Systems**

BASIC SEISMIC FORCE-RESISTING SYSTEM	DETAILING REFERENCE SECTION	RESPONSE MODIFICATION COEFFICIENT R^a	SYSTEM OVER-STRENGTH FACTOR, Ω_0^b	DEFLECTION AMPLIFICATION FACTOR, C_d^c	STRUCTURAL SYSTEM LIMITATIONS INCLUDING STRUCTURAL HEIGHT, h_n , (FEET) LIMITS BY SEISMIC DESIGN CATEGORY ^d				
					B	C	D ^e	E ^e	F ^f
6. Steel and concrete composite special concentrically braced frames	(H2) ^r	6	2-1/2	5	NL	NL	NL	NL	NL
7. Steel and concrete composite plate shear walls	(H6) ^r	7-1/2	2-1/2	6	NL	NL	NL	NL	NL
8. Steel and concrete composite special shear walls	(H5) ^r	7	2-1/2	6	NL	NL	NL	NL	NL
9. Steel and concrete composite ordinary shear walls	(H4) ^r	6	2-1/2	5	NL	NL	NP	NP	NP
10. Special reinforced masonry shear walls	(7.3.2.6) ^t	5-1/2	3	5	NL	NL	NL	NL	NL
11. Intermediate reinforced masonry shear walls	(7.3.2.5) ^t	4	3	3-1/2	NL	NL	NP	NP	NP
12. Steel buckling-restrained braced frames	(F4) ^r	8	2-1/2	5	NL	NL	NL	NL	NL
13. Steel special plate shear walls	(F5) ^r	8	2-1/2	6-1/2	NL	NL	NL	NL	NL
E. Dual Systems with Intermediate Moment Frames Capable of Resisting at Least 25% of Prescribed Seismic Forces [ASCE 7-16 12.2.5.1]									
1. Steel special concentrically braced frames ^p	(F2) ^r	6	2-1/2	5	NL	NL	35	NP	NP
2. Special reinforced concrete shear walls ^{g,h}	(18.2.1.6) ^s	6-1/2	2-1/2	5	NL	NL	160	100	100
3. Ordinary reinforced masonry shear walls	(7.3.2.4) ^t	3	3	2-1/2	NL	160	NP	NP	NP
4. Intermediate reinforced masonry shear walls	(7.3.2.5) ^t	3-1/2	3	3	NL	NL	NP	NP	NP

**Table 3-1 (Continued) Replacement for ASCE 7-16 Table 12.2-1
Design Coefficients and Factors for Basic Seismic Force-Resisting Systems**

BASIC SEISMIC FORCE-RESISTING SYSTEM	DETAILING REFERENCE SECTION	RESPONSE MODIFICATION COEFFICIENT R^a	SYSTEM OVER-STRENGTH FACTOR, Ω_0^b	DEFLECTION AMPLIFICATION FACTOR, C_d^c	STRUCTURAL SYSTEM LIMITATIONS INCLUDING STRUCTURAL HEIGHT, h_n , (FEET) LIMITS BY SEISMIC DESIGN CATEGORY ^d				
					B	C	D ^e	E ^e	F ^f
5. Steel and concrete composite special concentrically braced frames	(H2) ^r	5-1/2	2-1/2	4-1/2	NL	NL	160	100	NP
6. Steel and concrete composite ordinary braced frames	(H1) ^r	3-1/2	2-1/2	3	NL	NL	NP	NP	NP
7. Steel and concrete composite ordinary shear walls	(H4) ^r	5	3	4-1/2	NL	NL	NP	NP	NP
8. Ordinary reinforced concrete shear walls ^g	(18.2.1.6) ^s	5-1/2	2-1/2	4-1/2	NL	NL	NP	NP	NP
F. Shear Wall-Frame Interactive System with Ordinary Reinforced Concrete Moment Frames and Ordinary Reinforced Concrete Shear Walls^g	(18.2.1.6) ^s	4-1/2	2-1/2	4	NL	NP	NP	NP	NP
G. Cantilevered column systems detailed to conform to the requirements for [ASCE 7-16 12.2.5.2]:									
1. Steel special cantilever column systems	(E6) ^r	2-1/2	1-1/4	2-1/2	35	35	35	35	35
2. Steel ordinary cantilever column systems	(E5) ^r	1-1/4	1-1/4	1-1/4	35	35	NP ⁱ	NP ⁱ	NP ⁱ
3. Special reinforced concrete moment frames ^m	(18.2.1.6) ^s	2-1/2	1-1/4	2-1/2	35	35	35	35	35
4. Intermediate reinforced concrete moment frames	(18.2.1.6) ^s	1-1/2	1-1/4	1-1/2	35	35	NP	NP	NP
5. Ordinary reinforced concrete moment frames	(18.2.1.6) ^s	1	1-1/4	1	35	NP	NP	NP	NP
6. Timber frames	(2301 – 2307) ^u	1-1/2	1-1/2	1-1/2	35	35	35	NP	NP

**Table 3-1 (Continued) Replacement for ASCE 7-16 Table 12.2-1
Design Coefficients and Factors for Basic Seismic Force-Resisting Systems**

BASIC SEISMIC FORCE-RESISTING SYSTEM	DETAILING REFERENCE SECTION	RESPONSE MODIFICATION COEFFICIENT R^a	SYSTEM OVER-STRENGTH FACTOR, Ω_0^b	DEFLECTION AMPLIFICATION FACTOR, C_d^c	STRUCTURAL SYSTEM LIMITATIONS INCLUDING STRUCTURAL HEIGHT, h_n , (FEET) LIMITS BY SEISMIC DESIGN CATEGORY ^d				
					B	C	D ^e	E ^e	F ^f
H. Steel Systems Not Specifically Detailed for Seismic Resistance, Excluding Cantilevered Column Systems	AISC 360-10, AISI S100, AISI S240, ASCE 8	3	3	3	NL	NL	NP	NP	NP

**TABLE 3-1 (Continued) Replacement for ASCE 7-16 Table 12.2-1
Design Coefficients and Factors for Basic Seismic Force-Resisting Systems**

FOR SI: 1 foot (ft) = 304.8 mm, 1 pound per square foot (psf) = 0.0479 kN/m²

- a. Response modification coefficient, R , for use throughout. Note R reduces forces to a strength level, not an allowable stress level.
- b. Where the tabulated value of the overstrength factor, Ω_0 , is greater than or equal to $2\frac{1}{2}$, Ω_0 is permitted to be reduced by subtracting the value of $\frac{1}{2}$ for structures with flexible diaphragms.
- c. Deflection amplification factor, C_d , for use in **ASCE 7-16** Sections 12.8.6, 12.8.7, 12.9.1.2, **12.12.3, and 12.12.4**.
- d. NL= Not limited and NP = Not permitted. For metric units, use **30 m** for 100 ft and **50 m** for 160 ft.
- e. See **ASCE 7-16** Section 12.2.5.4 for a description of seismic force-resisting systems limited to buildings with a structural height, h_n , of 240 feet (**75 m**) or less.
- f. See **ASCE 7-16** Section 12.2.5.4 for seismic force-resisting systems limited to buildings with a structural height, h_n , of 160 feet (**50 m**) or less.
- g. In Section 2.3 of ACI 318, a shear wall is defined as a structural wall.
- h. In Section 2.3 of ACI 318, the definition of "special structural wall" includes precast and cast-in-place construction.
- i. An increase in structural height, h_n , to 45 ft (**14 m**) is permitted for single story storage warehouse facilities.
- j. Steel ordinary concentrically braced frames (**OCBFs**) are permitted in single-story buildings up to a structural height, h_n , of 60 ft (**18 m**) where the dead load of the roof does not exceed 20 psf (**1.0 kN/m²**) and in penthouse structures.
- k. See Section 12.2.5.7 for limitations in structures assigned to Seismic Design Categories D, E, or F.
- l. See Section 12.2.5.6 for limitations in structures assigned to Seismic Design Categories D, E, or F.

-
- m. In Section 2.3 of ACI 318, the definition of “special moment frame” includes precast and cast-in-place construction.
 - n. Cold-formed steel – special bolted moment frames must be limited to one-story in height in accordance with ANSI/AISI S400.
 - o. Alternately, the seismic load effect with overstrength, E_{mh} , is permitted to be based on the expected strength determined in accordance with ANSI/AISI S400.
 - p. Ordinary moment frame is permitted to be used in lieu of intermediate moment frame for Seismic Design Category B or C.
 - q. ***Ordinary Moment Frames are permitted to be used as part of the structural system that transfers forces between isolator units.***
 - r. ***ANSI/AISC 341-16 section number.***
 - s. ***ACI 318-14, Section 18.2.1.6 cites appropriate sections in ACI 318-14.***
 - t. ***TMS 402-16 section number.***
 - u. ***2018 IBC section numbers.***

3-6.4 **Section 12.10 - DIAPHRAGMS, CHORDS, AND COLLECTORS.**

12.10.2.1 Collector Elements Requiring Load Combinations with Overstrength Factor for Seismic Design Categories C through F

Item 3 [Replacement]. Forces calculated using the load combinations of Section 2.3.6 without overstrength factor, with seismic forces determined by Eq. (12.10-2).

EXCEPTIONS [Replacement]:

1 - In structures or portions thereof braced entirely by wood light-frame shear walls, collector elements and their connections, including connections to vertical elements, need only be designed to resist forces using the load combinations of Section 2.3.6 without overstrength factor, with seismic forces determined in accordance with Section 12.10.1.1.

[C] 12.10.2.1 Collector Elements Requiring Load Combinations with Overstrength Factor for Seismic Design Categories C through F

The two [Replacement] added under this section are intended to clarify that the load combinations to be used with these two provisions are the ones that do not include the overstrength factor. The text in ASCE 7-16 simply refers to the load combinations in Section 2.3.6. However, ASCE 7-16 Section 2.3.6 contains two sets of seismic load combinations – regular load combinations involving seismic load effects not amplified by the overstrength factor of the structure, and load combinations where the seismic load effects are amplified by the overstrength factor. The intent of ASCE 7-16 must use the load combinations that do not include the overstrength factor.

3-6.5 **Section 12.11 - STRUCTURAL WALLS AND THEIR ANCHORAGE.**

12.11.2.1 Wall Anchorage Forces [Supplement]

Refer to Figure 3-1 for determination of the span of flexible diaphragm, L_f .

Figure 2-1 Anchorage of Walls to Flexible Diaphragm

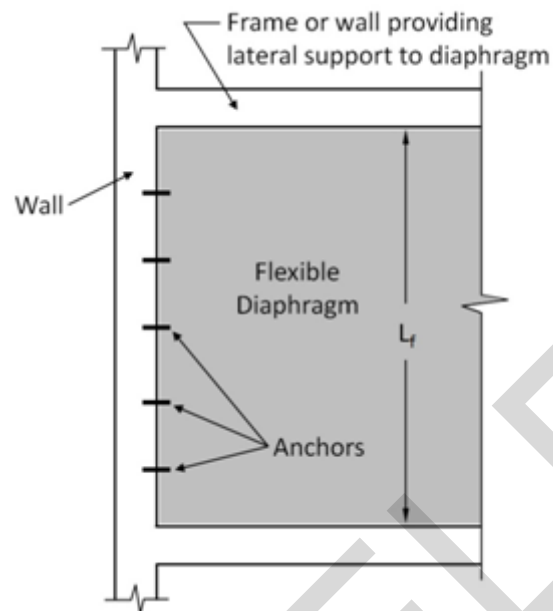

3-7 **ASCE 7-16 CHAPTER 13 – SEISMIC DESIGN REQUIREMENTS FOR NON-STRUCTURAL COMPONENTS.**

3-7.1 **Section 13.1 – GENERAL.**

13.1.1 Scope [Supplement]

Add as the second paragraph:

Appendix D of this UFC provides supplementary guidance on architectural, mechanical, and electrical component design requirements. Section D-2 provides guidance on architectural component design, including interior and exterior wall elements. Section D-3 provides guidance on electrical and mechanical systems design. To the extent that is practicable, subsections of Appendix D reference relevant sections of ASCE 7-16.

3-7.2 **Section 13.2 - GENERAL DESIGN REQUIREMENTS.**

13.2.2 Special Certification Requirements for Designated Seismic Systems [Supplement]

Appendix E of this UFC provides verification and certification guidance.

When shake table testing is performed, the Required Response Spectra (RRS) must be either derived using ICC-ES AC156 or developed from a site-specific in-structure response time history based study. In the case of the latter, the RRS for each axis must be generated from the time histories defined in Section 2-14.2 of

UFC 3-310-04, and be peak broadened by 15%. The in-structure response spectra per Section 2-16.4.4 of UFC 3-310-04 must be used to determine demand if the Nonstructural Component is not supported at grade.

Testing must be performed in accordance with nationally recognized testing procedures such as:

1. The requirements of the International Code Council Evaluations Service (ICC-ES), *Acceptance Criteria for Seismic Qualification by Shake-Table Testing of Nonstructural Components*, ICC-ES AC156, November 2010.
2. The *CERL Equipment Fragility and Protection Procedure (CEFAPP)*, USACERL Technical Report 97/58, Wilcoski, J., Gambill, J.B., and Smith, S.J., March 1997. The test motions, test plan, and results of this method require peer review.
3. For power substation equipment only, Institute of Electrical and Electronics Engineers (IEEE), *Recommended Practices for Seismic Design of Substations*, IEEE 693-2005.

Shake table tests must include triaxial motion components that result in the largest response spectral amplitudes at the natural frequencies of the equipment for each of the three axes of motion. The Test Response Spectrum (TRS) test motions, demand RRS, test plan, and test results must be reviewed independently by a team of Registered Design Professionals. The design professionals must have documented experience in the appropriate disciplines, seismic analysis, and seismic testing. The independent review must include, but need not be limited to, the following:

1. Review of site-specific seismic criteria, including the development of site-specific spectra and ground motion histories, and all other project-specific criteria;
2. Review of seismic designs and analyses for both the equipment and all supporting systems, including the generation of in-structure motions;
3. Review of all testing requirements and results; and,
4. Review of all equipment quality control, quality assurance, maintenance, and inspection requirements.

13.2.2.1 Component Certification and O&M Manual [Addition]

For any electrical or mechanical component required by ASCE 7-16 Section 13.2.2 to be certified, evidence demonstrating compliance with the requirement must be maintained in a file identified as "Equipment Certification Documentation." This file must be a part of the Operations & Maintenance (O&M) Manual that is turned over to the AHJ. The project specifications must require the O&M

Manual state that replaced or modified components need to be certified per the original certification criteria.

13.2.2.2 Component Identification Nameplate [Addition]

Any electrical or mechanical component required by ASCE 7-16 Section 13.2.2 to be certified is required to bear permanent marking or nameplates constructed of a durable heat and water resistant material. Nameplates must be mechanically attached to such nonstructural components and placed on each component for clear identification. The nameplate cannot be less than 5" x 7" with red letters 1" in height on a white background stating "Certified Equipment." The following statement is required to be on the nameplate: "This equipment/component is certified. No modifications are allowed unless authorized in advance and documented in the Equipment Certification Documentation file." The nameplate needs to also contain the component identification number in accordance with the drawings/specifications and the O&M manuals.

13.2.7 Construction Documents [Supplement]

Construction documents for architectural, mechanical, and electrical components must be prepared by a Registered Design Professional for all buildings assigned to RC IV.

3-7.3 Section 13.3 - SEISMIC DEMANDS ON NONSTRUCTURAL COMPONENTS.

13.3.2 Seismic Relative Displacements [Supplement]

Egress stairways and ramps must be detailed in accordance with ASCE 7-16 Section 13.5.10.

3-7.4 Section 13.4 - NONSTRUCTURAL COMPONENT ANCHORAGE.

13.4.2.2 Anchors in Masonry [Replacement]

Anchors in masonry must be designed in accordance with TMS 402-16. Additionally, at least one of the following must be satisfied in structures assigned to SDC C or higher.

- a. Anchors in tension are designed to be governed by the tensile strength of a ductile steel element.
- b. Anchors are designed for the maximum load that can be transmitted to the anchors from a ductile attachment, considering both material overstrength and strain hardening of the attachment.

- c. Anchors are designed for the maximum load that can be transmitted to the anchors by a non-yielding attachment.
- d. Anchors are designed for the maximum load obtained from design load combinations that include E , with E multiplied by Ω_0 as given in ASCE 7-16 Tables 13.5-1 and 13.6-1.

[C] 13.4.2.2 Anchors in Masonry [Replacement]

This [Replacement] harmonizes design of anchors embedded in concrete and masonry. ASCE 7-16 Section 13.4.2.2 includes provisions to prevent brittle failure in anchors in masonry attaching nonstructural components. This [Replacement] simply makes them consistent with ACI 318-14. Note Option a is available only for anchors in tension, and not those in shear. This [Replacement] also exempts anchorage in SDC A and B structures from these ductility/overstrength requirements, which is consistent with what is required for anchors in concrete.

13.4.2.3 Post-Installed Anchors in Concrete and Masonry [Replacement]

In structures assigned to SDC C or higher, post-installed mechanical anchors or adhesive anchors in concrete are required to be prequalified for seismic applications in accordance with ACI 355.2 or other approved qualification procedures. In structures assigned to SDC C or higher, post-installed anchors in masonry are required to be prequalified for seismic applications in accordance with approved qualification procedures.

[C] 13.4.2.3 Post-Installed Anchors in Concrete and Masonry [Replacement]

This [Replacement] specifies that ACI 355.2 is for prequalification of post-installed mechanical anchors only, and adds a reference to ACI 355.4 for prequalification of post-installed adhesive anchors, which is not referenced in ASCE 7-16.

3-7.5 **Section 13.5 - ARCHITECTURAL COMPONENTS.**

13.5.6 Suspended Ceilings [Supplement]

For buildings assigned to RC IV, suspended ceilings must be designed to resist seismic effects using a rigid bracing system, where the braces are capable of resisting tension and compression forces, or diagonal splay wires, where the wires are installed taut. Particular attention should be given in walk-down inspections (see Section 1705.12.6 in Chapter 2 of this UFC) to ensure splay wires are taut. Positive attachment must be provided to prevent vertical movement of ceiling ele-

ments. Vertical support elements need to be capable of resisting both compression and tensile forces. Vertical supports and braces designed for compression must have a slenderness ratio, Kl/r , of less than 200. Additional guidance on suspended ceiling design is provided in Section D-2.3.8 of this UFC.

13.5.7 Access Floors [Supplement]

Installed access floor components that have importance factors, I_p , greater than 1.0 must meet the requirements of Special Access Floors (ASCE 7-16 Section 13.5.7.2). Note: Equipment that requires certification (see Section 2-13.2.2 in this UFC) need to account for the motion amplification that occurs because of any supporting access flooring.

3-7.6 Section 13.6 - MECHANICAL AND ELECTRICAL COMPONENTS.

13.6.1 General [Supplement]

Stacks attached to or supported by buildings must be designed to meet the force and displacement provisions of ASCE 7-16 Sections 13.3.1 and 13.3.2. They must further be designed in accordance with the requirements of ASCE 7-16 Chapter 15 and the special requirements of ASCE 7-16 Section 15.6.2. Guidance on stack design may be found in Section D-3.2.

13.6.2 Mechanical Components [Supplement]

Guidance on the design of piping supports and attachments is found in Section D-3.1.4 of this UFC.

13.6.3 Electrical Components [Supplement]

Guidance on the design of electrical equipment supports, attachments, certification is found in Appendices D and E of this UFC.

13.6.4 Component Support [Supplement]

For buildings that are assigned to RC IV, guidance on the design of lighting fixtures is found in Section D-3.4 of this UFC.

13.6.4.5 Additional Requirements – Item 5 [Addition]

The local regions of support attachment for all mechanical and electrical equipment must be evaluated for the effects of load transfer on component walls and other structural elements.

13.6.11.3 Seismic Controls for Elevators [Supplement]

For buildings that are assigned to RC IV, or in SDCs E or F, the trigger level for seismic switches must be set to 50% of the acceleration of gravity along both orthogonal horizontal axes. Elevator systems (equipment, systems, supports, etc) in RC IV or SDCs E or F buildings will have an $I_p = 1.5$ and must be designed to ensure elevator operability at accelerations below 50% of the acceleration of gravity along both orthogonal horizontal axes. Additional guidance on the design of elevator systems is found in Section D-3.3 of this UFC.

[C] 13.6.11.3 Seismic Switches [Supplement]

Note that the 0.50g is consistent with Article 3137, *Seismic Requirements for Elevators, Escalators and Moving Walks*, Subchapter 6, Elevator Safety Orders, California Code of Regulations, Title 8 (<http://www.dir.ca.gov/title8/3137.html>).

13.6.12 Rooftop Solar Panels [Deletion]

Delete the exception to this section in its entirety.

[C] 13.6.12 Rooftop Solar Panels [Deletion]

The exception addresses ballasted solar panels without positive direct attachment to roof structure. However, ballasted systems are specifically disallowed by UFC 3-110-03, *Roofing*.

13.6.14 Bridges, Cranes, and Monorails [Addition]

Structural supports for those crane systems that are located in buildings and other structures assigned to SDC C with I_p greater than 1.0, or assigned to SDC D, E, or F, must be designed to meet the force and displacement provisions of ASCE 7-16 Section 13.3. Seismic forces, F_p , must be calculated using a component amplification factor, a_p , of 2.5 and a component response modification factor, R_p , of 2.5, except that crane rail connections must be designed for the forces resulting from an R_p of 1.5 in all directions. When designing for forces in either horizontal direction, the weight of crane components, W_p , need not include any live loads, lifted loads, or loads from crane components below the bottom of the crane cable. If the crane is not in a locked position, the lateral force parallel to the crane rails can be limited by the friction forces that can be applied through the brake wheels to the rails. In this case, the full rated live load of the crane plus the weight of the crane must be used to determine the gravity load that is carried by each wheel. Guidance on the design of these systems is found in Section D-3.5 of this UFC.

13.6.14.1 Bridges, Cranes, and Monorails for RC IV Buildings [Addition]

In addition to the requirements of Section 13.6.14 of this UFC, for bridges, cranes, and monorails for all RC IV buildings, vertical earthquake-induced motions corresponding to the MCE_R event must be considered. When a site-specific vertical spectrum is not used, the vertical response spectrum may be developed following the provisions of ASCE 7-16 Section 11.9.2.

3-8 ASCE 7 CHAPTER 15 – SEISMIC DESIGN REQUIREMENTS FOR NONBUILDING STRUCTURES.

3-8.1 Section 15.4 - STRUCTURAL DESIGN REQUIREMENTS.

15.4.5 – Drift Limit [Replacement]

Nonbuilding structures similar to buildings are required to comply with lateral drift requirements as specified for buildings in Chapter 12, ASCE 7-16.

Exception: The drift limitations of Section 12.12.1 need not apply to nonbuilding structures if a rational analysis acceptable to the AHJ indicates they can be exceeded without adversely affecting structural stability or attached or interconnected components and elements such as walkways and piping. *P*-delta effects need to be considered where critical to the function or stability of the structure.

15.4.9.2 Anchors in Masonry [Replacement]

Anchors in masonry must be designed in accordance with TMS 402-16. Additionally, for non-building structures assigned to SDC C, D, E, or F, at least one of the following must be satisfied.

- a. Design anchors in tension to be governed by the tensile strength of a ductile steel element.
- b. Anchors are designed for the maximum load that can be transmitted to the anchors from a ductile attachment, considering both material overstrength and strain hardening of the attachment.
- c. Anchors are designed for the maximum load that can be transmitted to the anchors by a non-yielding attachment.
- d. Anchors are designed for the maximum load obtained from design load combinations that include E , with E multiplied by Ω_0 as given in ASCE 7-16 Tables 13.5-1 and 13.6-1.

[C] 15.4.9.2 Anchors in Masonry [Replacement]

This [Replacement] harmonizes design of anchors embedded in concrete and masonry. ASCE 7-16 Section 15.4.9.2 includes provisions to prevent brittle failure in anchors in masonry in nonbuilding structures. This [Replacement] simply

makes them consistent with ACI 318-14. Note Option 'a' is available only for anchors in tension, not shear.

15.4.9.3 Post-Installed Anchors in Concrete and Masonry [Replacement]

Post-installed mechanical anchors in concrete in non-building structures assigned to SDC C, D, E, or F are required to be prequalified for seismic applications in accordance with ACI 355.2 or other approved qualification procedures. Post-installed adhesive anchors in concrete in non-building structures assigned to SDC C, D, E, or F are required to be prequalified for seismic applications in accordance with ACI 355.4 or other approved qualification procedures. Post-installed anchors in masonry non-building structures assigned to SDC C, D, E, or F are required to be prequalified for seismic applications in accordance with approved qualification procedures.

[C] 15.4.9.3 Post-Installed Anchors in Concrete and Masonry [Replacement]

This [Replacement] specifies that ACI 355.2 is for prequalification of post-installed mechanical anchors only, and adds a reference to ACI 355.4 for prequalification of post-installed adhesive anchors, which is not referenced in ASCE 7-16.

3-8.2 Section 15.5 - NONBUILDING STRUCTURES SIMILAR TO BUILDINGS.

15.5.6.1 General [Supplement]

UFC 4-152-01, *Design: Piers and Wharves*, governs the seismic design of piers and wharves for the DoD.

15.5.6.2 Design Basis [Deletion]

Delete this section in its entirety.

3-8.3 Section 15.7 - TANKS AND VESSELS.

15.7.5 Anchorage [Replacement]

Tanks and vessels at grade are permitted to be designed without anchorage where they meet the requirements for unanchored tanks in reference documents. Tanks and vessels supported above grade on structural towers or building structures must be anchored to the supporting structure.

Anchorage must be in accordance with Chapter 17 of ACI 318. Post-installed anchors are permitted to be used in accordance with Section 15.4.9.3. For anchors

in tension, where the special seismic provisions of ACI 318 Section 17.2.3.4.2 apply, the requirements of ACI 318 Section 17.2.3.4.3(a) must be satisfied.

15.7.11.7(b) [Replacement]

Anchorage must be in accordance with Chapter 17 of ACI 318. Post-installed anchors are permitted to be used in accordance with Section 15.4.9.3. For anchors in tension, where the special seismic provisions of ACI 318 Section 17.2.3.4.2 apply, the requirements of ACI 318 Section 17.2.3.4.3(a) must be satisfied.

3-9 ASCE 7 CHAPTER 26 – WIND LOADS: GENERAL REQUIREMENTS

3-9.1 **Section 26.12 ENCLOSURE CLASSIFICATION**

26.12.1 General. [Supplement]

Design all fire station garage bays as partially enclosed structures, with the assumption that garage bay doors have failed. The remainder of the fire station, if isolated from garage bay internal pressure, may be designed according to standard code provisions.

[C] 26.12.1 - General [Supplement]

Damage experienced during Hurricane Michael in 2018 included multiple instances of roof diaphragm loss due to exterior roll-up and sectional door failures, including a fire station where bay doors failed, followed by a total loss of roof diaphragm.

CHAPTER 4 SEISMIC EVALUATION AND RETROFIT OF EXISTING BUILDINGS

4-1 GENERAL

The provisions of this chapter apply to matters governing the repair, alteration, change of occupancy, acquisition, addition to and relocation of existing buildings. The following documents are hereby adopted for these purposes:

1. ICSSC RP 8 / NIST GCR 11-917-12, *Standards of Seismic Safety for Existing Federally Owned and Leased Buildings*, cited herein as RP 8. RP 8 is applicable to all existing DoD owned and leased buildings at all locations worldwide.
2. Prescriptive Compliance Method of the 2018 International Existing Building Code (2018 IEBC)

Modifications are made to specific sections of the 2018 IEBC and RP 8. It is expected that designers may highlight or otherwise mark those paragraphs of the 2018 IEBC and RP 8 that are modified by this chapter. The required 2018 IEBC and RP 8 section modifications are one of three actions, according to the following legend:

[Addition] – New section added, includes new section number not shown in the 2018 IEBC or RP 8.

[Replacement] – Delete referenced 2018 IEBC or RP 8 section and replace it with the narrative shown.

[Supplement] – Add narrative shown as a supplement to the narrative shown in the referenced section of the 2018 IEBC or RP 8.

Where the provisions of RP 8 and IEBC are in conflict, those of RP 8 govern. Where RP 8 makes no specific provision, the provisions of the IEBC, as modified by this Chapter, govern.

For repairs, alterations, acquisitions, and changes of occupancy, the provisions of RP 8, as modified by this chapter, must be used.

For additions and relocation of buildings, the provisions of the Prescriptive Compliance Method of the 2018 IEBC, as modified by this chapter, govern.

[C] 4-1 Scope

RP 8 gives exemptions, triggers, scope, and criteria applicable to alterations, repairs, changes of occupancy, acquisitions, and (in general terms) historic buildings; in these cases, where the Prescriptive Compliance Method of the 2018 IEBC has different provisions or no provisions at all, the RP 8 provisions (as modified by this chapter) must be used, whether they are more restrictive or less restrictive than the IEBC.

RP 8 uses the national standards ASCE/SEI 31-03 and ASCE/SEI 41-06 as criteria for seismic evaluation and retrofit, respectively. This chapter uses the combined update to those standards, known as ASCE/SEI 41-13.

RP 8 does not contain provisions for additions or relocated buildings; in these cases, 2018 IEBC provisions apply, as modified by this chapter.

This Chapter clarifies certain terms used in RP 8 and the application of RP 8 to various risk categories. RP 8's exemptions and benchmarking provisions are also modified by this chapter.

The 2018 IEBC contains three alternative compliance methods. This UFC specifies the use of only the Prescriptive Compliance Method. This method is closest in organization to what used to be Chapter 34 of the IBC. Starting with the 2015 IBC, Chapter 34 was replaced by a reference to the IEBC; the 2018 IBC references the 2018 IEBC. This makes it necessary to select one of the IEBC compliance methods.

4-2 MODIFICATIONS TO RP 8

Apply the following modifications to RP 8.

RP 8 Section 1.0 [Supplement]. Wherever RP 8 cites ASCE/SEI 31-03 or ASCE/SEI 41-06, the corresponding section or provision of ASCE/SEI 41-13 must be used instead.

RP 8 Section 2.1 (b) [Replacement]. For buildings assigned to Seismic Design Category C, a project is planned, the cost of which totals more than 50% of the replacement value of the building.

RP 8 Section 2.1 (c) [Replacement]. For buildings assigned to Seismic Design Category D, E, or F, a project is planned, the cost of which totals more than 30% of the replacement value of the building.

Where seismic evaluation or retrofit is required, ASCE/SEI 41-13 must be used. Performance objectives for evaluation or retrofit must be as specified in the following subsections.

4-2.1 Performance Objectives for Evaluation and Retrofit using ASCE 41-13

4-2.1.1 Buildings Assigned to Risk Category I, II, III, or IV

Performance objectives for seismic evaluation or retrofit of buildings assigned to risk category I, II, III, or IV using ASCE 41-13 must be as follows:

Risk Category	Scope item	Evaluation Performance Objective ^{2,4}	Retrofit Performance Objective ⁴
I or II	Structural	Life Safety in BSE-1E	Life Safety in BSE-1N and Collapse Prevention in BSE-2N
	Nonstructural ¹	Life Safety in BSE-1E	Life Safety in BSE-1N
III	Structural	Damage Control in BSE-1E ³	Damage Control in BSE-1N and Limited Safety in BSE-2N
	Nonstructural ¹	Life Safety in BSE-1N	Life Safety in BSE-1N
IV	Structural	Immediate Occupancy in BSE-1E	Immediate Occupancy in BSE-1N and Life Safety in BSE-2N
	Nonstructural ¹	Position Retention in BSE-1E	Operational in BSE-1N

¹ At the AHJ's discretion, the Nonstructural scope may be waived in areas of the building not affected by the project and not affecting DoD operations, safety, or post-earthquake occupancy.

² At the AHJ's discretion, Tier 3 evaluation at the BSE-2E hazard level may also be required, consistent with ASCE/SEI 41-13 Table 2-1.

³ Tier 1 or Tier 2 evaluation at the Damage Control level must use the Tier 1 checklists and Tier 2 procedures for Life Safety performance, but M_s -factors and other quantitative limits must be taken as the average of Life Safety and Immediate Occupancy values.

⁴ See ASCE41-13 for definitions of BSE-1E, BSE-1N, and BSE-2N.

[C] 4-2.1.1 Buildings Assigned to Risk Category I, II, III, or IV. In general, the ASCE 41-13 performance objectives were selected to maintain the same expected performance and scope of work as those in the May 1, 2012 edition of UFC 3-310-04 (retired). There is one significant exception: For buildings assigned to risk category IV, the nonstructural retrofit objective in the May 1, 2012 edition would have translated to "Position Retention in BSE-1N." Instead, "Operational in BSE-1N" is specified to ensure that critical equipment will receive the ruggedness certification required for Operational performance. Also, note that for risk category III buildings, the nonstructural evaluation objective uses the hazard level BSE-1N, not BSE-1E. This is intended to

capture the effect of the 25 percent force increase required in the May 1, 2012 edition of UFC 3-310-04 (retired).

Note that enhanced performance, such as operation of designated essential equipment following the BSE-2N, may be desirable and would be based on the discretion of the AHJ.

4-2.2 Exemptions and Benchmark Buildings

4-2.2.1 Exemptions

Where applied to projects involving change of occupancy, exemptions in RP 8 Section 1.3 based on occupancy or use apply to the new or intended occupancy.

RP 8 Section 1.3 item a [Replacement]. a. All buildings assigned to SDC A.

RP 8 Section 1.3 item b [Replacement]. b. All buildings assigned to SDC B.

RP 8 Section 1.3 item c [Replacement]. c. Detached one- and two-family dwellings located where $S_{DS} < 0.4 g$.

RP 8 Section 1.3, item d [Replacement]. d. Risk category I or II building structures intended for incidental human occupancy or that are occupied by persons for a total of less than 2 hours a day.

RP 8 Section 1.3 item e [Replacement]. e. Risk category I or II one-story buildings of steel light frame or wood construction with areas less than 280 m² (3000 ft²).

[C] 4-2.2.1 Exemptions

The revisions to RP 8 Section 1.3 provide the enforcing agency guidance referenced in RP 8 Section C1.3 regarding relative risk. RP 8 Section 1.3 refers to safety-based performance objectives and occupancy-based performance objectives. Per Section 4-2.1 of this UFC, those correspond directly to a building's risk category. Therefore, Section 4-2.2.1 recasts certain RP 8 exemptions in terms of risk category.

4-2.2.2 Benchmark Buildings

Where the Benchmark Building provisions of ASCE 41-13 apply, Table 4-1 of this chapter must replace ASCE 41-13 Table 4-6, Benchmark Buildings, and RP 8 Table 1-1, Benchmark Buildings.

4-2.2.3 ACQUISITION

Leased, purchased, donated buildings, or portions of such buildings, must comply with applicable provisions of RP 8.

[C] 4-2.2.3 ACQUISITION

RP 8 addresses leased, purchased, and donated buildings and portions of buildings in Sections 1.3.2, 1.3.3, and 2.1.e. Since the IEBC does not address acquisitions, this section is added for clarity and completeness.

4-3 MODIFICATIONS TO 2018 IEBC CHAPTER 5

4-3.1 Section 502 - ADDITIONS

502.1.1 – Combined Projects [Addition]

Alteration work performed in conjunction with an addition project must comply with the provisions for alteration projects. Repair work performed in conjunction with an addition project must comply with the provisions for repair projects.

[C] 502.1.1 – Combined Projects [Addition]

In general, RP 8 and the 2018 IEBC make provisions based on the intended project type. This section addresses cases where multiple project types, one of which is an addition, are intended. The provision is primarily a pointer to the requirements in Section 4-3 in this chapter.

502.5 – Existing Structural Elements Carrying Lateral Load, Exception 1 [Replacement]

Exceptions:

1. Any existing seismic force-resisting structural element whose demand-capacity ratio with the addition considered is no more than 10 percent greater than its demand-capacity ratio with the addition ignored is permitted to remain unaltered provided the addition neither creates new structural irregularities, as defined in ASCE 7-16 Section 12.3.2, nor makes existing structural irregularities more severe. For purposes of calculating demand-capacity ratios, the demand needs to consider applicable load combinations that include wind or earthquake load effects. For purposes of this exception, comparisons of demand-capacity ratios and calculation of design lateral loads, forces and capacities must account for the cumulative effects of additions and alterations since original construction.

4-3.2 **Section 503 - ALTERATIONS**

503.1 – General [Supplement]

The following requirements apply to projects involving additions to existing buildings.

If no alterations are made to an existing structure that receives a new structurally independent addition, then seismic evaluation of the existing structure is not required. If alterations are made to an existing structure that receives a new structurally independent addition, the requirements of RP 8 must be met for the existing structure.

[C] 503.1 – General [Supplement]

RP 8 addresses the triggers, exemptions, scope, and criteria for seismic evaluation and retrofit associated with alteration projects.

Note that the RP 8 trigger for alteration projects (RP 8 Section 2.1.b) is based on the cost of the alteration relative to the facility's replacement value, whereas the IEBC trigger is based on changes to demand-capacity ratios resulting from the intended work. Also, 2018 IEBC Sections 503.5 through 503.11 include additional proactive seismic retrofit triggers for "major" alterations and reroofing alterations. RP 8 does not include these triggers. Since, in case of a conflict, RP 8 governs over the IEBC, this UFC also does not require compliance with those IEBC provisions.

4-3.3 **Section 506 - CHANGE OF OCCUPANCY**

[C] Section 506 - CHANGE OF OCCUPANCY

RP 8 addresses the triggers, exemptions, scope, and criteria for seismic evaluation and rehabilitation associated with change of occupancy projects.

Note that the RP 8 trigger for change of occupancy projects (RP 8 Section 2.1.a) is based on a case-by-case understanding of the proposed change, "as determined by the agency," whereas the IEBC trigger is based only on a change of risk category.

4-3.4 **Section 507 - HISTORIC BUILDINGS**

[C] Section 507 - HISTORIC BUILDINGS

RP 8 addresses historic buildings in Section 4.7.

Note that the RP 8 provisions for historic buildings generally require compliance, whereas the IEBC provisions do not.

4-3.5 **Section 508 - MOVED STRUCTURES [ADDITION]**

508.1 Conformance. [Addition]

Structures moved into or within the jurisdiction must comply with the provisions required for new structures.

CANCELLED

◇ Replacement for ASCE 41-13 Table 4-6, Benchmark Buildings

Building Type ^{1,2}	Building Seismic Design Provisions					Seismic Evaluation or Retrofit Provisions			Tri-Services Criteria ⁹		
	NBC ^{LS}	SBC ^{LS}	UBC ^{LS}	IBC ^{LS}	NEHRP ^{LS}	FEMA 178 ^{LS}	FEMA 310/ASCE 31 ^{LS, IO}	FEMA 356/ASCE/SEI 41 ^{LS7, IO8}	Design		Evaluation
									LS	IO	LS, IO
Wood Frame, Wood Shear Panels (Types W1 & W2)	1993	1994	1976	2000	1985	*	1998	2000	1982	1986	1999
Wood Frame, Wood Shear Panels (Type W1A)	*	*	1997	2000	1997	*	1998	2000	1998	1998	1999
Steel Moment-Resisting Frame (Types S1 & S1A)	*	*	1994 ⁴	2000	1997	*	1998	2000	1998	1998	1999
Steel Centrally Braced Frame (Types S2 & S2A)	*	*	1997	2000	*	*	1998	2000	1992	1992	1999
Steel Eccentrically Braced Frame (Types S2 & S2A)	*	*	1988 ⁴	2000	1997	*	*	2000	1992	1992	1999
Buckling-Restrained Braced Frame (Types S2 & S2A)	*	*	*	2006	*	*	*	2000	1992	1992	1999
Light Metal Frame (Type S3)	*	*	*	2000	*	1992	1998	2000	1992¹⁰	1998¹⁰	1999

Table 4-1 (Continued) Replacement for ASCE 41-13 Table 4-6, Benchmark Buildings

Building Type ^{1,2}	Building Seismic Design Provisions					Seismic Evaluation or Retrofit Provisions			Tri-Services Criteria ⁹		
	NBC ^{LS}	SBC ^{LS}	UBC ^{LS}	IBC ^{LS}	NEHRP ^{LS}	FEMA 178 ^{LS}	FEMA 310/ASCE 31 ^{LS, IO}	FEMA 356/ASCE/SEI 41 ^{LS7, IO8}	Design		Evaluation
									LS	IO	LS, IO
Steel Frame w/Concrete Shear Walls (Type S4)	1993	1994	1994 ⁹	2000	1985	*	1998	2000	1982	1986	1999
Steel Frame with URM Infill (Types S5 & S5A)	*	*	*	2000	*	*	1998	2000	*	NP	1999
Steel Plate Shear Wall (Type S6)	*	*	*	2006	*	*	*	2000	*	*	*
Reinforced Concrete Moment-Resisting Frame (Type C1) ³	1993	1994	1994	2000	1997	*	1998	2000	1982	1986	1999
Reinforced Concrete Shear Walls (Types C2 & C2A)	1993	1994	1994	2000	1985	*	1998	2000	1982	1986	1999
Concrete Frame with URM Infill (Types C3 & C3A)	*	*	*	2000	*	*	1998	2000	*	NP	1999
Tilt-up Concrete (Types PC1 & PC1A)	*	*	1997	2000	*	*	1998	2000	1998	1998	1999

Table 4-1 (Continued) Replacement for ASCE 41-13 Table 4-6, Benchmark Buildings

Building Type ^{1,2}	Building Seismic Design Provisions					Seismic Evaluation or Retrofit Provisions			Tri-Services Criteria ⁹		
	NBC ^{LS}	SBC ^{LS}	UBC ^{LS}	IBC ^{LS}	NEHRP ^{LS}	FEMA 178 ^{LS}	FEMA 310/ASCE 31 ^{LS, IO}	FEMA 356/ASCE/SEI 41 ^{LS7, IO8}	Design		Evaluation
									LS	IO	LS, IO
Precast Concrete Frame (Types PC2 & PC2A)	*	*	*	2000	*	1992	1998	2000	1998	1998	1999
Reinforced Masonry Bearing Walls w/Flexible Diaphragms (Type RM1)	*	*	1997	2000	*	*	1998	2000	1998	1998	1999
Reinforced Masonry Bearing Walls w/Stiff Diaphragms (Type RM2)	1993	1994	1994 ⁹	2000	1985	*	1998	2000	1982	1986	1999
Unreinforced Masonry Bearing Walls w/Flexible Diaphragms (Type URM)5	*	*	1991 ⁶	2000	*	1992	1998	2000	*	NP	1999 (LS only)
Unreinforced Masonry Bearing Walls w/Stiff Diaphragms (Type URMA)	*	*	*	2000	*	*	1998	2000	*	NP	1999

Table 4-1 (Continued) Replacement for ASCE 41-13 Table 4-6, Benchmark Buildings

Building Type ^{1,2}	Building Seismic Design Provisions					Seismic Evaluation or Retrofit Provisions			Tri-Services Criteria ⁹		
	NBC ^{LS}	SBC ^{LS}	UBC ^{LS}	IBC ^{LS}	NEHRP ^{LS}	FEMA 178 ^{LS}	FEMA 310/ ASCE 31 ^{LS, IO}	FEMA 356/ ASCE/SEI 41 ^{LS7, IO8}	Design		Evaluation
									LS	IO	LS, IO
Seismic Isolation or Passive Dissipation	*	*	1991	2000	*	*	*	2000	*	*	*
Load-Bearing Cold-Formed Steel Framing (Not listed in ASCE/SEI 41-13)	N/A	N/A	N/A	N/A	N/A	N/A	N/A	2000	1998 ¹¹	1998 ¹¹	1999

CANCELED

Table 4-1 (Continued) Replacement for ASCE 41-13 Table 4-6, Benchmark Buildings

Notes:

- ¹ Building Type refers to one of the Common Building Types defined in **ASCE 41-13** Table 2-2.
- ² Buildings on hillside sites shall not be considered Benchmark Buildings.
- ³ Flat slab concrete moment frames shall not be considered Benchmark Buildings.
- ⁴ Steel moment-resisting frames and eccentrically braced frames with links adjacent to columns shall comply with the 1994 UBC Emergency Provisions, published September/October 1994, or subsequent requirements.
- ⁵ URM buildings evaluated or retrofitted and shown to be acceptable using Special Procedure (the ABK Methodology, 1984) may be considered benchmark buildings subject to the limitation of Section 15.2.
- ⁶ Refers to the GSREB or its predecessor, the Uniform Code of Building Conservation (UCBC), or its successor, IEBC Appendix Chapter A1.
- ⁷ S-3 Structural Performance Level for the BSE-1.
- ⁸ S-1 Structural Performance Level for the BSE-1.
- ⁹ ***The Tri-Services Criteria Benchmark Year provisions apply only to the structural aspects of the evaluation; older retrofits designed using Tri-Service Criteria need to be evaluated for compliance with the new standards. Nonstructural and foundation elements shall require a minimum Tier 1 evaluation, in accordance with ASCE 41-13, except under the following circumstances:***
- a. The building was designed and constructed in accordance with TI 809-04 or later Tri-Services criteria; or,***
 - b. The building was evaluated in accordance with TI 809-05 or later Tri-Services criteria, and the building evaluation and rehabilitation included structural, nonstructural, geotechnical, and foundation measures.***
- ¹⁰ ***Pre-engineered metal buildings designed in accordance with 1992 criteria using ASCE 7-16 loading may be considered as Benchmark Buildings for Life Safety Performance Objective, only if all other applicable restrictions are met. Pre-engineered metal buildings designed in accordance with 1998 criteria, including TI 809-30, Metal Building Systems, may be considered as Benchmark Buildings for both the Life Safety and Immediate Occupancy Performance Objectives, only if all other applicable restrictions are met.***
- ¹¹ ***This benchmark year is based in the initial publication of TI 809-07, Design of Cold-Formed Load-Bearing Steel System and Masonry Veneer Steel Stud Walls, 1998.***
- ^{LS} Only buildings designed and constructed or evaluated in accordance with these documents and being evaluated to the Life-Safety Performance Level may be considered Benchmark Buildings.
-

Table 4-1 (Continued) Replacement for ASCE 41-13 Table 4-6, Benchmark Buildings

¹⁰ Buildings designed and constructed or evaluated in accordance with these documents and being evaluated to the Immediate Occupancy Performance Level may be considered Benchmark Buildings.

* No benchmark year; buildings shall be evaluated using **ASCE 41-13**.

NP – Not Permitted. Tri-Services guidance does not permit the use of URM.

NBC – Building Code Officials and Code Administrators (BOCA), *National Building Code*, 1993.

SBC – Southern Building Code Congress (SBCC), *Standard Building Code*, 1994.

UBC – International Conference of Building Officials (ICBO), *Uniform Building Code*, **year as shown in table**.

GSREB – ICBO, *Guidelines for Seismic Retrofit of Existing Buildings*, 2001.

IBC – International Code Council, *International Building Code*, 2000.

NEHRP – Federal Emergency Management Agency (FEMA), *NEHRP Recommended Provisions for the Development of Seismic Regulations for New Buildings*. **Years shown in table refer to editions of document.**

FEMA 178 – FEMA, *NEHRP Handbook for the Seismic Evaluation of Existing Buildings*, 1992.

FEMA 310 – FEMA, *Handbook for the Seismic Evaluation of Buildings – A Prestandard*, 1998. **FEMA 310 was superseded by ASCE 31-03, which in turn has been superseded by ASCE 41-13.**

FEMA 356 - FEMA, *Prestandard and Commentary for the Seismic Rehabilitation of Existing Buildings - FEMA 356 was superseded by ASCE 41-06, which in turn has been superseded by ASCE 41-13.*

ASCE 31 – ASCE, *Seismic Evaluation of Existing Buildings*, 2003

ASCE/SEI 41 – ASCE, *Seismic Rehabilitation of Existing Buildings*, 2006

Tri-Services Criteria:

1982 – TM 5-809-10; NAVFAC P-355; AFM 88-3, Ch 13, Seismic Design for Buildings, 1982.

1986 – TM 5-809-10-1; NAVFAC P-355.1; AFM 88-3, Ch 13, Sec A, Seismic Design Guidelines for Essential Buildings, 1986.

1988 – TM 5-809-10-2; NAVFAC P-355.2; AFM 88-3, Ch 13, Sec B, Seismic Design Guidelines for Upgrading Existing Buildings, 1988.

Table 4-1 (Continued) Replacement for ASCE 41-13 Table 4-6, Benchmark Buildings

1992 – TM 5-809-10; NAVFAC P-355; AFM 88-3, Ch 13, Seismic Design for Buildings, 1992.

CANCELLED

CHAPTER 5 NONBUILDING STRUCTURES

5-1 HIGHWAY BRIDGE DESIGN.

Design of highway bridges is required to be in accordance with *AASHTO* LRFD Bridge Design Specifications. Design examples are available in the PCI Bridge Design Manual and the following links

- *LRFD Design Examples* (<http://www.fhwa.dot.gov/bridge/lrfd/examples.cfm>)
- *Reference Manual* (<http://www.fhwa.dot.gov/bridge/pubs/nhi15047.pdf>)

5-2 RAILROAD BRIDGE DESIGN.

Design of railroad bridges is required to be in accordance with the AREMA Manual for Railway Engineering.

5-3 TANKS FOR LIQUID STORAGE.

Design of tanks for liquid storage is required to be in accordance with NFPA 22, AWWA D100, AWWA D103, AWWA D107, AWWA D115, AWWA D110 and AWWA D120 as applicable.

5-4 TANKS FOR PETROLEUM STORAGE.

Design of tanks for petroleum storage is required to be in accordance with UFC 3-460-01.

5-5 ENVIRONMENTAL ENGINEERING CONCRETE STRUCTURES.

Design of environmental engineering concrete structures is required to be in accordance with ACI 350.

5-6 PRESTRESSED CONCRETE TANKS.

Design of prestressed concrete tanks is required to be in accordance with ACI 372R.

5-7 WATER TREATMENT FACILITIES.

Design of water treatment facilities is required to be in accordance with the Water Environment Federation (WEF) Manual of Practice 8.

5-8 TRANSMISSION TOWERS AND POLES.

Design of transmission towers is required to be in accordance with ASCE 10. Design of transmission poles is required to be in accordance with IEEE Standards Association's National Electric Safety Code.

5-9 ANTENNA TOWERS.

Design of antenna towers is required to be in accordance with ANSI/TIA-222-G.

5-10 PEDESTRIAN BRIDGES.

Design of pedestrian bridges is required to be in accordance with the AASHTO LRFD Guide Specifications for Design of Pedestrian Bridges.

CANCELLED

CHAPTER 6 MODIFICATIONS TO THE IBC FOR CRITICAL HEALTHCARE FACILITIES

6-1 IBC CHAPTER 1 – SCOPE AND ADMINISTRATION

6-1.1 Section 101 - GENERAL

101.2 – Scope. [Supplement]

For the seismic design of the facilities listed below assigned to SDC D, E, or F, the modifications to 2018 IBC Chapters 16, 18, 19, 21, and 22 included in this chapter apply in addition to those in Chapter 2 of this UFC. Where the provisions of this chapter and those in the 2018 IBC or in Chapter 2 of this UFC are in conflict, the provisions of this chapter govern.

- Group I-2, Condition 2 occupancies, as defined in 2018 IBC Section 308.3, having emergency surgery or emergency treatment facilities.
- Ambulatory care facilities having emergency surgery or emergency treatment facilities.

6-2 IBC CHAPTER 16 – STRUCTURAL DESIGN

6-2.1 Section 1603 - CONSTRUCTION DOCUMENTS

1603.1.5 – Earthquake Design Data. [Supplement]

Add the following three items to the list:

12. Applicable horizontal structural irregularities.
13. Applicable vertical structural irregularities.
14. Location of base as defined in ASCE 7-16 Section 11.2.

6-3 IBC CHAPTER 18 - SOILS AND FOUNDATIONS

6-3.1 Section 1807 – FOUNDATION WALLS, RETAINING WALLS AND EMBEDDED POSTS AND POLES

1807.1.1 - Design Lateral Soil Loads. [Replacement]

Foundation walls must be designed for the lateral soil loads determined by a geotechnical investigation, in accordance with Section 1803.

1807.1.3 – Rubble Stone Foundation Walls. [Replacement]

Rubble stone foundation walls are not permitted.

1807.1.4 - Permanent Wood Foundation Systems. [Replacement]

Permanent wood foundation systems are not permitted.

1807.2.2 – Design Lateral Soil Loads [Replacement]

Design Retaining walls for lateral soil loads determined by a geotechnical investigation in accordance with Section 1803 subject to a minimum of eighty percent of the lateral soil loads determined in accordance with Section 1610. Apply seismic earth pressure increases to seismic loads in applicable load combinations.

6-4 IBC CHAPTER 19 - CONCRETE

6-4.1 Section 1901 – GENERAL

1901.5 - Construction Documents [Supplement]

Add the following item to the list:

12. Openings larger than 12 inches (305 mm) in any dimension must be detailed on the structural drawings.

6-4.2 Section 1903 – SPECIFICATIONS FOR TESTS AND MATERIALS

1903.5 – Steel Fiber Reinforcement [Addition]

Steel fiber reinforcement is not permitted.

6-4.3 Section 1905 – MODIFICATIONS TO ACI 318

1905.1.9 – ACI 318, Section 12.7.3 [Addition]

Add Section 12.7.3.4 to ACI 318 as follows:

12.7.3.4 - At least two No. 5 bars in diaphragms having two layers of reinforcement in both directions and one No. 5 bar in diaphragms having a single layer of reinforcement in both directions must be provided around openings larger than 12 inches in any dimension in addition to the minimum reinforcement required by Section 12.6. Extend bars beyond the opening sufficient to develop their capacity.

1905.1.10 – ACI 318, Section 18.12.6 [Addition]

Add Section 18.12.6.2 to ACI 318 as follows:

18.12.6.2 – *Precast topping slabs containing collector and/or boundary reinforcement must not be less than 3 inches (76 mm) or $6d_b$ thick, where d_b is the diameter of the largest reinforcement element in the topping slab.*

6-4.4 **Section 1908 - SHOTCRETE**

1908.10.2 – Panel Criteria [Supplement]

Add the following sentence at the end of the paragraph:

Obtain approval from the AHJ prior to performing the test panel method.

6-5 IBC CHAPTER 21 - MASONRY

6-5.1 **Section 2101 - GENERAL**

2101.5 - Prohibition [Addition]

The following design, systems and materials are not permitted:

- 1 Unreinforced masonry
- 2 Autoclaved aerated concrete (AAC) masonry
- 3 Empirical design of masonry
- 4 Adobe construction
- 5 Ordinary reinforced masonry shear walls
- 6 Intermediate reinforced masonry shear walls
- 7 Prestressed masonry shear walls
- 8 Simplified Direct Design procedure for masonry
- 9 Celersap (common European in place clay tile forming system for concrete floors)

6-5.2 **Section 2106 - SEISMIC DESIGN**

2106.1.1 - Minimum Reinforcement Requirements for Masonry Walls. [Addition]

The total area of reinforcement in reinforced masonry walls must not be less than 0.003 times the sectional area of the wall. Neither the horizontal nor the vertical reinforcement is permitted to be less than one third of the total. Horizontal and vertical reinforcement must be spaced at not more than 24 inches (610 mm) on center. The smallest bar diameter permitted is No. 4, except that No. 3 bars may be used for ties and stirrups. Vertical wall reinforcement needs to have dowels of

equal size and equal matched spacing in all footings. Reinforcement must be continuous around wall corners and through intersections. Only reinforcement that is continuous in the wall is permitted in computing the minimum area of reinforcement. Reinforcement with splices conforming to TMS 402-16 can be considered as continuous reinforcement.

Horizontal reinforcing bars in bond beams must be provided at the top of footings, at the top of wall openings, at roof and floor levels, and at the top of parapet walls. For walls 12 inches (nominal) (305 mm) or more in thickness, horizontal and vertical reinforcement must be equally divided into two layers, except where designed as retaining walls. Where reinforcement is added above the minimum requirements, such additional reinforcement need not be so divided.

Provide trim bars around openings in reinforced masonry walls of not less than one number 5 bar (or two number 4 bars) for all openings greater than 24 inches (406mm) in any direction. Extend said trim bars 24 inches or 48 bar diameters beyond the opening, whichever is greater. Trim bars noted in this requirement are in addition to minimum reinforcement elsewhere.

When reinforcement in bearing walls is designed, placed and anchored in position as for columns, the allowable stresses must be as for columns.

Joint reinforcement is not permitted to be used as principal reinforcement in masonry.

2106.1.2 – Lateral Support of Masonry Walls. [Addition]

Lateral support of masonry walls may be provided by cross walls, columns, pilasters, counterforts or buttresses where spanning horizontally or by floors, beams, girts or roofs where spanning vertically. Where walls are supported laterally by vertical elements, the stiffness of each vertical element must exceed that of the tributary area of the wall.

2106.1.3 – Anchor Bolts [Addition]

Bent bar anchor bolts are not permitted. The maximum size anchor permitted is 1/2-inch (13 mm) diameter for 6-inch (152 mm) nominal masonry, 3/4-inch (19 mm) diameter for 8-inch (203 mm) nominal masonry, 7/8-inch (22 mm) diameter for 10-inch (254 mm) nominal masonry, and 1-inch (25 mm) diameter for 12-inch (304.8 mm) nominal masonry.

6-5.3 Section 2107 - ALLOWABLE STRESS DESIGN

2107.5 – Thickness of walls [Addition]

For thickness limitations of walls as specified in Chapter 8 of TMS 402-16, nominal thickness must be used. Stresses must be determined on the basis of the

net thickness of the masonry, with consideration for reduction, such as raked joints.

The thickness of masonry walls must be designed so that allowable maximum stresses specified in Chapter 8 of TMS 402-16 are not exceeded. Also, masonry walls are not permitted to exceed the height or length-to-thickness ratio or the minimum thickness as specified in Chapter 8 of TMS 402-16 and as set forth in Table 6-1.

6-6 IBC CHAPTER 22 - STEEL

6-6.1 Section 2210 - COLD-FORMED STEEL

2210.1.1.2 – Steel Roof Deck [Supplement]

Add the following to the end of the paragraph:

Steel roof deck is not permitted to be thinner than 20-gauge.

6-6.2 Section 2211 - COLD-FORMED STEEL LIGHT-FRAMED CONSTRUCTION

2211.1.1.1 - Prohibitions [Addition]

The following systems are not permitted within the seismic force-resisting system of a building:

1. Shear wall assemblies per Section C2.2.3 of AISI S213
2. Prescriptive framing

Renumber Sections 2211.1.1.1 ([Addition] in Chapter 2 of this UFC), 2211.1.1.2 and 2211.1.1.3 as 2211.1.1.2, 2211.1.1.3 and 2211.1.1.4, respectively.

Table 6-1 Minimum Thickness of Masonry Walls^{1,2}

Type of Masonry	Maximum Ratio of Unsupported Height or Length to Thickness ^{2,3}	Nominal Minimum Thickness (Inches)
Bearing or Shear Walls:		
1. Stone masonry	14	16
2. Reinforced grouted masonry	25	6
3. Reinforced hollow unit masonry	25	6
Nonbearing Walls:		
4. Exterior reinforced walls	30	6
5. Interior reinforced partitions	36	4

1. For varying thickness, use the least thickness when determining the height or length to thickness ratio.
2. In determining the height or length-to-thickness ratio of a cantilevered wall, use a dimension that is twice the dimension of the end of the wall from the lateral support.
3. Cantilevered walls not part of a building and not carrying applied vertical loads need not meet these minimum requirements but their design must comply with stress and overturning requirements.

CHAPTER 7 MODIFICATIONS TO ASCE 7-16 FOR CRITICAL HEALTHCARE FACILITIES

7-1 ASCE 7-16 CHAPTER 11 – SEISMIC DESIGN CRITERIA

7-1.1 Section 11.1 – GENERAL

11.1.2 – Scope [Supplement]

For the facilities listed below and assigned to SDC D, E, or F, the modifications to ASCE 7-16 included in this chapter apply in addition to those in Chapter 3 of this UFC. Where the provisions of this chapter and those in ASCE 7-16 or in Chapter 3 of this UFC are in conflict, the provisions of this chapter govern.

- Group I-2, Condition 2 occupancies, as defined in 2018 IBC Section 308.3, having emergency surgery or emergency treatment facilities.
- Ambulatory care facilities having emergency surgery or emergency treatment facilities.

7-2 ASCE 7-16 CHAPTER 12 – SEISMIC DESIGN REQUIREMENTS FOR BUILDING STRUCTURES

7-2.1 Section 12.1 – STRUCTURAL DESIGN BASIS

12.1.7 – Structural Configuration. [Addition]

The following configuration limitations apply to structures within the scope of this chapter.

1. Bay spacing must be essentially equal and uniform throughout.
2. Transfer beams or trusses supporting upper-level columns are not to be used unless permitted on a case by case basis by the AHJ.
3. Seismic joints must be avoided, if at all possible. When required, they need to be specifically identified in the schematic design phase of the project and approved by the AHJ, subject to the following provisions:
 - a. Seismic joints must be properly detailed on the working drawings;
 - b. Seismic joints must be sized based on the maximum expected displacements, considering the effects of story drift, diaphragm displacements and rotations, and a realistic approximation of element section properties. For materials designed considering the ultimate limit state, such as concrete, the stiffness representative of this state must be

used. Seismic separations must be at least 125% of the separation required by ASCE 7-16.

4. Adjacent structures that are not integral with an existing structure must be separated by not less than 2 inches per story.

12.1.8 – Limitations on Seismic Force-Resisting Reinforced Concrete Structural Members. [Addition]

Lightweight concrete is not permitted to be used in structural members resisting seismic forces, except in concrete floors and roof slabs used as diaphragm elements to distribute earthquake forces to vertical seismic force-resisting elements.

12.1.9 – Limitations on Seismic Force-Resisting Steel Structural Members. [Addition]

Steel eccentrically braced systems must be subject to the additional limitation that connections of nonstructural components are not to be located in the vicinity of EBF link beams. Such connections include, but are not limited to, precast panel connections, elevator guide rail supports, staircase supports, pipe supports, etc.

7-2.2 **Section 12.2 – STRUCTURAL SYSTEM SELECTION**

12.2.1 - Selection and Limitations. [Supplement]

Table 7-1, Replacement for ASCE 7-16 Table 12.2-1, must be used in lieu of ASCE 7-16 Table 12.2-1. Only the structural systems included in Table 7-1 are permitted to be used in structures within the scope of this chapter.

Unless specifically prohibited in Chapter 6 of this UFC, other structural systems that are permitted by ASCE 7-16 for SDC D, E or F, including those employing seismic isolation and seismic damping systems are permitted subject to written approval by the AHJ. Proposals to obtain written approval for other structural systems must demonstrate the equivalent performance of those systems, relative to the permitted systems, considering (a) initial construction and maintenance costs, (b) requirements for bracing nonstructural components and building contents, (c) risk of economic losses and disruption to hospital functions due to earthquakes and (d) other demonstrable benefits.

12.2.3.2 - Two-Stage Analysis Procedure. [Supplement]

Add the following requirement:

- f. Where design elements of the upper portion is governed by the seismic load effects with overstrength, as defined in ASCE 7-16 Section 12.4.3, the amplified loads must be considered in the design of the lower portion.

Replacement for ASCE 7-16 Table 12.2-1 Design Coefficients and Factors for Basic Seismic Force-Resisting Systems

BASIC SEISMIC FORCE-RESISTING SYSTEM	DETAILING REFERENCE SECTION	RESPONSE MODIFICATION COEFFICIENT R^a	OVERSTRENGTH FACTOR, Ω_0^b	DEFLECTION AMPLIFICATION FACTOR, C_d^c	STRUCTURAL SYSTEM LIMITATIONS INCLUDING STRUCTURAL HEIGHT, h_n , (FEET) LIMITS BY SEISMIC DESIGN CATEGORY ^d				
					B	C	D ^e	E ^e	F ^f
B. Building Frame Systems									
1. Steel eccentrically braced frames	(F3) ^r	8	2	4	NL	NL	160	160	100
2. Steel special concentrically braced frames	(F2) ^r	6	2	5	NL	NL	160	160	100
4. Special reinforced concrete shear walls ^{g,h}	(18.2.1.6) ^s	6	2-1/2	5	NL	NL	160	160	100
16. Special reinforced masonry shear walls	(7.3.2.6) ^t	5-1/2	2-1/2	4	NL	NL	160	160	100
22. Light-frame (wood) walls sheathed with wood structural panels rated for shear resistance	(2301-2307) ^u	7	2-1/2	4-1/2	NL ^v	NL ^v	65 ^v	65 ^v	65 ^v
23. Light-frame (cold-formed steel) walls sheathed with wood structural panels rated for shear resistance or with steel sheets	(2211, 2301-2307) ^u	7	2-1/2	4-1/2	NL ^v	NL ^v	65 ^v	65 ^v	65 ^v
25. Steel buckling-restrained braced frames	(F4) ^r	8	2-1/2	5	NL	NL	160	160	100

C. Moment-Resisting Frame Systems									
1. Steel special moment frames	(E3) ^r	8	3	5-1/2	NL	NL	NL	NL	NL
5. Special reinforced concrete moment frames ^m	(18.2.1.6) ^s	8	3	5-1/2	NL	NL	NL	NL	NL
D. Dual Systems with Special Moment Frames Capable of Resisting at Least 25% of Prescribed Seismic Forces [ASCE 7-16 12.2.5.1]									
1. Steel eccentrically braced frames	(F3) ^r	8	2-1/2	4	NL	NL	NL	NL	NL

**Table 7-1 (Continued) Replacement for ASCE 7-16 Table 12.2-1
Design Coefficients and Factors for Basic Seismic Force-Resisting Systems**

BASIC SEISMIC FORCE-RESISTING SYSTEM	DETAILING REFERENCE SECTION	RESPONSE MODIFICATION COEFFICIENT R^a	SYSTEM OVER-STRENGTH FAC-TOR, Ω_0^b	DEFLECTION AMPLIFICATION FACTOR, C_d^c	STRUCTURAL SYSTEM LIMITATIONS INCLUDING STRUCTURAL HEIGHT, h_n , (FEET) LIMITS BY SEISMIC DESIGN CATEGORY ^d				
					B	C	D ^e	E ^e	F ^f
2. Steel special concentrically braced frames	(F2) ^r	7	2-1/2	5-1/2	NL	NL	NL	NL	NL
3. Special reinforced concrete shear walls ^{g,h}	(18.2.1.6) ^s	7	2-1/2	5-1/2	NL	NL	NL	NL	NL
10. Special reinforced masonry shear walls	(7.3.2.6) ^t	5-1/2	3	5	NL	NL	NL	NL	NL
12. Steel buckling-restrained braced frames	(F4) ^r	8	2-1/2	5	NL	NL	NL	NL	NL

FOR SI: 1 foot (ft) = 304.8 mm, 1 pound per square foot (psf) = 0.0479 kN/m²

- a. Response modification coefficient, R , for use throughout. Note R reduces forces to a strength level, not an allowable stress level.
- b. Where the tabulated value of the overstrength factor, Ω_0 , is greater than or equal to 2½, Ω_0 is permitted to be reduced by subtracting the value of ½ for structures with flexible diaphragms.
- c. Deflection amplification factor, C_d , for use in **ASCE 7** Sections 12.8.6, 12.8.7, 12.9.1.2, **12.12.3, and 12.12.4**.
- d. NL= Not limited and NP = Not permitted. For metric units, use **30 m** for 100 ft and **50 m** for 160 ft.
- e. See **ASCE 7-16** Section 12.2.5.4 for a description of seismic force-resisting systems limited to buildings with a structural height, h_n , of 240 feet (**75 m**) or less.
- f. See **ASCE 7-16** Section 12.2.5.4 for seismic force-resisting systems limited to buildings with a structural height, h_n , of 160 feet (**50 m**) or less.
- g. In Section 2.3 of ACI 318, a shear wall is defined as a structural wall.

- h. In Section 2.3 of ACI 318, the definition of “special structural wall” includes precast and cast-in-place construction.
- m. In Section 2.3 of ACI 318, the definition of “special moment frame” includes precast and cast-in-place construction.
- r. ***ANSI/AISC 341-16 section number.***
- s. ***ACI 318-14, Section 18.2.1.6 cites appropriate sections in ACI 318-14.***
- t. ***TMS 402-16 section number.***
- u. ***2018 IBC section numbers.***
- v. ***Permitted only for structures up to two-stories***

CANCELLED

7-2.3 **Section 12.3 - DIAPHRAGM FLEXIBILITY, CONFIGURATION IRREGULARITIES, AND REDUNDANCY**

12.3.3.1 - Prohibited Horizontal and Vertical Irregularities for Seismic Design Categories D through F. [Replacement]

Structures having horizontal structural irregularity Type 1b of ASCE 7-16 Table 12.3-1 or vertical structural irregularities Type 1b, 5a or 5b of ASCE 7-16 Table 12.3-2 are not permitted.

7-2.4 **Section 12.12 - DRIFT AND DEFORMATION**

12.12.3 - Structural Separation. [Replacement]

Replace ASCE 7-16 Equation 12.12-1 by the following:

$$\Delta_M = C_d \Delta_{MAX} \quad (\text{Equation 12.12-1})$$

7-2.5 **ASCE 7-16 CHAPTER 13 – SEISMIC DESIGN REQUIREMENTS FOR NON-STRUCTURAL COMPONENTS**

7-2.6 **Section 13.2 - GENERAL DESIGN REQUIREMENTS**

13.2.2 - Special Certification Requirements for Designated Seismic Systems [Supplement]

Special Seismic Certification must be provided in accordance with the requirements of ASCE 7-16 Section 13.2.2, except for equipment and components that are considered rugged as listed in Section 2.2 of OSHPD Code Application Notice (CAN) No. 2-1708A.5, issued by the California Office of Statewide Health Planning and Development (OSHPD).

Items prequalified under the Special Seismic Certification Preapproval (OSP) program of OSHPD are deemed to possess Special Seismic Certification required by ASCE 7-16 Section 13.2.2.

[C] 13.2.2 - Special Certification Requirements for Designated Seismic Systems [Supplement]

The California Office of Statewide Health Planning and Development (OSHPD) has published Code Application Notice (CAN) 2-1708A.5, which explicitly explains OSHPD's expectations as they relate to special seismic certification. The main focus of the CAN is to emphasize items requiring physical shake table testing. OSHPD has also created a Special Seismic Certification Preapproval (OSP) program. This program offers a means to obtain prequalification of product lines for special seismic certification. Lists of equipment that is pre-approved by

OSHPD can be found at <http://www.oshpd.ca.gov/FDD/Pre-Approval/SpecSeis-Cert-IrgeScrn-wModelCol.html> and <http://www.oshpd.ca.gov/FDD/Pre-Approval/OSP-List-by-Category.pdf>. The basis of OSHPD preapproval is always shake table testing in compliance with ICC-ES AC156 and satisfaction of ICC-ES AC156 post-test acceptance criteria.

7-2.7 Section 13.4 - NONSTRUCTURAL COMPONENT ANCHORAGE

13.4.2.3 - Post-Installed Anchors in Concrete and Masonry [Replacement]

Revise section title to: **Prequalified Post-Installed Anchors and Specialty Inserts in Concrete and masonry.**

Replace text with: Post-installed anchors and specialty inserts in concrete that are pre-qualified for seismic applications in accordance with ACI 355.2, ACI 355.4, ICC-ES AC193, ICC-ES AC232, ICC-ES AC308 or ICC-ES AC446 are permitted. Post-installed anchors in masonry must be pre-qualified for seismic applications in accordance with ICC-ES AC01, AC58 or AC106.

Use of screw anchors is limited to dry interior conditions. Screw anchors are not permitted for use in building exterior envelopes. Re-use of screw anchors or screw anchor holes is not permitted.

7-2.8 Section 13.5 - ARCHITECTURAL COMPONENTS

13.5.7 - Access Floors [Supplement]

All access floors must be special access floors in accordance with ASCE 7-16 Section 13.5.7.2.

7-2.9 Section 13.6 - MECHANICAL AND ELECTRICAL COMPONENTS

13.6.6 Distribution Systems: Duct Systems. [Replacement]

Replace Exception 2 with: Design for the seismic forces of Section 13.3 are not required where provisions are made to avoid impact with other ducts or mechanical components or to protect the ducts in the event of such impact, the distribution system is positively attached to the structure; and HVACR ducts have a cross-sectional area of 6 ft² (0.557 m²) or less, or weigh 10 lb/ft (146 N/m) or less.

13.6.11.1.1 Elevators guide rail support. [Addition]

The design of guide rail support-bracket fastenings and the supporting structural framing must use the weight of the counterweight or maximum weight of the car plus not less

than 40 percent of its rated load. The seismic forces must be assumed to be distributed one third to the top guiding members and two thirds to the bottom guiding members of cars and counterweights, unless other substantiating data are provided. In addition to the requirements of ASCE 7-16, Section 13.6.11.1, the minimum seismic forces must be 0.5g acting in any horizontal direction.

CANCELLED

CHAPTER 8 MODIFICATIONS TO IEBC

8-1 IEBC PART 1 – SCOPE AND APPLICATION

8-1.1 101.2 – Scope [Supplement]

11Repairs, Alterations, Additions and Changes of Occupancy of Existing Buildings and Other Structures as defined by the 2018 International Existing Building Code (IEBC) does not apply to ASCE 7-16 Tsunami Load and Effects.

[C] 101.2 - Scope [Supplement]

The IEBC does not currently incorporate Tsunami requirements. Accordingly, this supplement is provided as clarification. This may change with future editions of the IEBC./1/

8-2 IEBC CHAPTER 5 - PRESCRIPTIVE COMPLIANCE METHOD

8-2.1 Section 501 – General

503.12 – Roof Diaphragms Resisting Wind Loads in High-wind Regions [Replacement]

When a building alteration 11or repair/1/ is performed where the basic design wind speed for RC II structures is greater than 115 mph (51 m/s) or in a special wind region in accordance with this UFC, roof diaphragms, diaphragm connections to roof framing members and diaphragm-to-wall connections must be evaluated for wind loads specified in this UFC, provided at least one of the following conditions occurs and this provision has not been invoked in the previous 25 years:

1. The cost of the alteration or repair exceeds 50% of replacement value for the building.
2. Reroofing a risk category III or IV building that involves removal of more than 50 percent of roofing material.

If the diaphragm and/or diaphragm connections are found incapable of resisting 75 percent of current UFC design wind loads they must be replaced or strengthened in accordance with current design wind loads specified in this UFC.

Exception: The following building types are exempt from this requirement:

- Reinforced concrete buildings with concrete diaphragms
- Reinforced concrete masonry unit buildings with concrete diaphragms.

- Detached one and two family dwellings
- Multiple single-family dwellings (townhouses) with less than eight attached dwelling units not more than three stories above grade.
- Risk Category I buildings

8-3 IEBC CHAPTER 7 – ALTERATIONS - LEVEL ONE

8-3.1 **SECTION 703 - GENERAL**

**706.3.2 - Roof Diaphragms Resisting Wind Loads in High-wind Regions
[Replacement]**

Apply section 503.12 of the previous UFC section.

CANCELLED

APPENDIX A REFERENCES

GOVERNMENT PUBLICATIONS:

- California Department of Industrial Relations
2701 Ocean Park Blvd # 220,
Santa Monica, CA 90405
- Article 3137, Seismic Requirements for Elevators, Escalators and Moving Walks, Subchapter 6, Elevator Safety Orders, California Code of Regulations, Title 8 (<http://www.dir.ca.gov/title8/3137.html>), 1998*
- California Office of Statewide Health Planning and Development
400 R Street #359
Sacramento, CA 95811-6213
<http://www.oshpd.ca.gov>
- Certification of Equipment and Nonstructural Components, Code Application Notice (CAN) No. 2-1708A.5, Effective October 31, 2008, Revised June 26, 2009*
- Department of Defense
1090 Vermont Avenue, NW, Suite 700 | Washington, DC 20005-4950
<http://dod.wbdg.org/>
- UFC 1-200-01, DoD Building Code (General Building Requirements), 2016 Edition*
- UFC 3-110-03, Roofing, 2004 Edition*
- UFC 3-130-01, General Provisions - Arctic and Subarctic Construction, 2004 Edition*
- UFC 3-130-06, Calculation Methods for Determination of Depth of Freeze and Thaw in Soil – Arctic and Subarctic Construction, 2004 Edition*
- UFC 3-220-01, Geotechnical Engineering, 2012 Edition*
- UFC 3-260-02, Pavement Design for Airfields, 2001 Edition*
- UFC 3-310-04, Seismic Design of Risk Category V Structures (Archived)*
- UFC 3-320-06A, Concrete Floor Slabs on Grade Subjected to Heavy Loads, 2005 Edition*

UFC 3-460-01, *Design: Petroleum Fuel Facilities*, 2010 Edition

UFC 4-010-01, *DoD Minimum Antiterrorism Standards for Buildings*, 2012 Edition

UFC 4-023-03, *Design of Buildings to Resist Progressive Collapse*, 2009 Edition

UFC 4-152-01, *Design: Piers and Wharves*, 2017 Edition

UFGS, *Unified Facilities Guide Specifications*

Federal Emergency Management
Agency
500 C Street, SW
Washington, DC 20472
<http://www.fema.gov>

FEMA 310, *Seismic Evaluation of Buildings – A Prestandard*, 1998 Edition (Superseded by ASCE 31 and 41)

FEMA 178, *Seismic Evaluation of Existing Buildings*, 2013.

FEMA 356, *Prestandard and Commentary for the Seismic Rehabilitation of Existing Buildings*, 2000 Edition (Superseded by ASCE 41)

FEMA P-361, *Safe Rooms for Tornadoes and Hurricanes: Guidance for Community and Residential Safe Rooms*, Third Edition (2015)

FEMA P-750, *NEHRP Recommended Provisions for Seismic Regulations for New Buildings and Other Structures*, 2009 Edition, Part 1: Provisions

FEMA P-750, *NEHRP Recommended Provisions for Seismic Regulations for New Buildings and Other Structures*, 2009 Edition, Part 2: Commentary

FEMA P-750, *NEHRP Recommended Provisions for Seismic Regulations for New Buildings and Other Structures*, 2009 Edition, Part 3: Resource Papers (RP) on Special Topics in Seismic Design

- FEMA P-1026 / March 2015, *Seismic Design of Rigid Wall – Flexible Diaphragm Buildings: An Alternate Procedure*
- National Institute of Standards and Technology
Building and Fire Research Laboratory
100 Bureau Drive, Stop 8600
Gaithersburg, MD 20899-8600
<http://www.nist.gov/index.html>
- ICSSC RP 8 / NIST GCR 11-917-12, *Standards of Seismic Safety for Existing Federally Owned and Leased Buildings*, December 2011
- NIST GCR 10-917-5, NEHRP Seismic Design Technical Brief No. 4, *Nonlinear Structural Analysis for Seismic Design*, October 2010
- Occupational Safety & Health Administration
200 Constitution Ave., NW,
Washington, DC 20210
<http://www.osha.gov/>
- 29 CFR, Part 1910, *Notices of Proposed Rulemaking*
- 29 CFR, Part 1910, *Occupational Safety and Health Standards for General Industry*
- 29 CFR, Part 1926, *Safety and Health Regulations for Construction*
- U.S. Army Corps of Engineers
441 G Street NW
Washington, DC 20314-1000
<http://www.usace.army.mil/>
- TM 5-809-10 / NAVFAC P-355 / AFM 88-3, Chap. 13 *Seismic Design for Buildings*, 1982 and 1992 Editions
- TM 5-809-10-1 / NAVFAC P-355.1 / AFM 88-3, CHAP. 13, SEC A *Seismic Design Guidelines for Essential Buildings*, 27 February 1986
- TM 5-809-10-2 / NAVFAC P-355.2 / AFM 88-3, Chapter 13, Sec B, 1 September 1988
- TI 809-04 *Seismic Design for Buildings*, 31 December 1998
- TI 809-05 *Seismic Evaluation and Rehabilitation for Buildings*, November 1999

TI 809-07 *Design of Cold-Formed Load-Bearing Steel Systems and Masonry Veneer / Steel Stud Walls*, 30 November 1998

TI 809-30 *Metal Building Systems*, 1 August 1998

USACERL Technical Report 97/58, *The CERL Equipment Fragility and Protection Procedure (CEFAPP)*, Wilcoski, J., Gambill, J.B., and Smith, S.J., March 1997

USACERL Technical Report 98/34, *Seismic Mitigation for Equipment at Army Medical Centers*, Wilcoski, J., 1998

U.S. Department of Energy
1000 Independence Ave., SW
Washington, DC 20585
<http://energy.gov/ehss/doeeh-0545-seismic-evaluation-procedure-equipment-us-department-energy-facilities-1997>

DOE/EH-0545, *Seismic Evaluation Procedure for Equipment in U.S. Department of Energy Facilities*, March 1997

Volume 4 of DOE Binders: SAND92-0140 Part I, UC-523, *Use of Seismic Experience Data to Show Ruggedness of Equipment in Nuclear Power Plants*, Revision 4, Senior Seismic Review and Advisory Panel, Sandia National Laboratories, June 1992

NON-GOVERNMENT PUBLICATIONS:

American Association of State Highway and Transportation Officials
444 N Capitol St. NW
Suite 249
Washington, DC 20001
<http://www.transportation.org>

LRFD Bridge Design Specifications, Customary U.S. Units

LRFD Guide Specifications for the Design of Pedestrian Bridges

American Concrete Institute
38800 Country Club Dr.
Farmington Hills, MI 48331-3439
<http://www.concrete.org/>

ACI 223R, *Guide for the Use of Shrinkage-Compensating Concrete*, 2010 Edition

ACI 224R, *Control of Cracking in Concrete Structures*, 2001 Edition

ACI 224.3R, *Joints in Concrete Construction*, 1995 Edition

ACI 302.1R, *Guide for Concrete Floor and Slab Construction*, 2015 Edition

ACI 302.2R, *Guide for Concrete Slabs that Receive Moisture-Sensitive Flooring Materials*, 2006 Edition

ACI 318, *Building Code Requirements for Structural Concrete*, 2014 Edition

ACI 350, *Code Requirements for Environmental Engineering Concrete Structures*, 2006 Edition

ACI 350.4R, *Design Considerations for Environmental Engineering Concrete Structures*, 2004 Edition

ACI 351.3R, *Report on Foundations for Dynamic Equipment*, 2018 Edition

ACI 355.2, *Qualification of Post-Installed Mechanical Anchors in Concrete and Commentary*, 2007 Edition

ACI 355.4, *Qualification of Post-Installed Adhesive Anchors in Concrete and Commentary*, 2011 Edition

ACI 357R, *Guide for the Design and Construction of Fixed Offshore Concrete Structures*, 1984 Edition

ACI 360R, *Guide to Design of Slabs-on-Ground*, 2010 Edition

ACI 364.3R, *Guide for Cementitious Repair Material Data Sheet*, 2009 Edition

ACI 372R, *Guide to Design and Construction of Circular Wire-and-Strand-Wrapped Prestressed Concrete Structures*, 2013 Edition

American Institute of Steel Construction
One East Wacker Drive, Suite 700
Chicago, IL 60601-1802
<http://www.aisc.org/>

ANSI/AISC 341, *Seismic Provisions for Structural Steel Buildings*, 2016

AISC 360, *Specification for Structural Steel Buildings*, 2016 Edition

AISC Steel Design Guide 1, *Base Plate and Anchor Rod Design*, 2nd Edition

AISC Steel Design Guide 3, *Serviceability Design Considerations for Steel Buildings*, 2nd Edition

AISC Steel Design Guide 11, *Vibrations of Steel-Framed Structural Systems Due to Human Activity*, 2nd Edition

RCSC *Specification for Structural Joints Using High-Strength Bolts*, 2009 Edition

Ivan Gomez, Amit Kanvinde, Chris Smith and Gregory Deierlein, *Shear Transfer in Exposed Column Base Plates*, 2009

American Iron and Steel Institute
25 Massachusetts Ave.
NW Suite 800
Washington, D.C. 20001
<http://www.steel.org/>

AISI S100, *North American Specification for the Design of Cold-Formed Steel Structural Members*, 2012 Edition

AISI S240, *North American Standard For Cold-Formed Steel Structural Framing*, 2015 Edition

AISI S400, *North American Standard for Seismic Design of Cold-Formed Steel Structural Systems*, 2015 Edition with Supplement 1 of 2016

J. H. Garrett, Jr., G. Haaijer, and K. H. Klippstein, *Effective Lengths for Laterally Unbraced Compression Flanges of Continuous Beams Near Intermediate Supports*, Proceedings, Sixth International Specialty Conference on Cold-Formed Steel Structures, 1982(<http://www.ccfsonline.org/>)

American Railway Engineering and Maintenance-of-Way Association
4501 Forbes Blvd., Suite 130
Lanham, MD 20706
<http://www.arena.org/>

Manual for Railway Engineering, 2018 Edition

American Society of Civil Engineers
1801 Alexander Bell Dr,
Reston, VA 20191
<http://www.asce.org>

ASCE 7-16, *Minimum Design Loads and Associated Criteria for Buildings and Other Structures*, 2016 Edition

ASCE 31, *Seismic Evaluation of Existing Buildings*, 2003 Edition

ASCE 32, *Design and Construction of Frost-Protected Shallow Foundations*, 2001 Edition

ASCE 41, *Seismic Evaluation and Retrofit of Existing Buildings*, 2013 Edition

ASCE 10, *Design of Latticed Steel Transmission Structures*, 2015 Edition

Background on the Development of the NEHRP Seismic Provisions for Non-Structural Components and their Application to Performance Based Seismic Engineering, Gillengerten, J.D., and Bachman, R.E., ASCE Structures Congress, 2003

American Society of Mechanical Engineers
Two Park Avenue
New York, NY 10016-5990
<http://www.asme.org>

ASME B31.1, *Power Piping*, 2016 Edition

ASME B31.3, *Process Piping*, 2016 Edition

ASME B31.4, *Pipeline Transportation Systems for Liquid Hydrocarbons and Other Liquids*, 2016 Edition

ASME B31.5, *Refrigeration Piping and Heat Transfer Components*, 2016 Edition

ASME B31.8, *Gas Transmission and Distribution Piping Systems*, 2016 Edition

ASME B31.9, *Building Services Piping*, 2014 Edition

American Society of Safety Engineers
520 N Northwest Hwy, Park Ridge,
IL 60068
<http://www.asse.org>

ANSI/ASSE A1264.1, *Safety Requirements for Workplace Walking/Working Surfaces and Their Access; Workplace Floor, Wall and Roof Openings, Stairs and Guardrail/Handrail Systems*, 2017 Edition

ANSI/ASSE Z359, *Fall Protection Code Package, Version 3.0*

ANSI/ASSE Z359.6, *Specifications and Design Requirements for Active Fall Protection Systems*, 2016 Edition

American Society for Metals
ASM World Headquarters
9639 Kinsman Road
Materials Park, OH 44073-0002
<https://www.asminternational.org>

ASM Handbook Volume 13B, *Corrosion: Materials*, 2005 Edition

American Water Works Association
6666 W. Quincy Ave.
Denver, CO 80235-3098
<http://www.awwa.org/>

AWWA D100, *Welded Carbon Steel Tanks for Water Storage*, 2011 Edition

AWWA D103, *Factory-Coated Bolted Steel Tanks for Water Storage*, 2009 Edition

AWWA D107, *Composite Elevated Tanks for Water Storage*, 2016 Edition

AWWA D110, *Wire- and Strand-Wound, Circular, Prestressed Concrete Water Tanks*, 2013 Edition

AWWA D115, *Tendon-Prestressed Concrete Water Tanks*, 2017 Edition

AWWA D120, *Thermosetting Fiberglass-Reinforced Plastic Tanks*, 2009 Edition

ASTM International (formerly American Society for Testing and Materials)
100 Barr Harbor Drive
PO Box C700
West Conshohocken
PA 19428-2959
<http://www.astm.org/>

ASTM A653/A653M, *Standard Specification for Steel Sheet, Zinc-Coated (Galvanized) or Zinc-Iron Alloy-Coated (Galvannealed) by the Hot-Dip Process*, 2017 Edition

ASTM C157/C157M, *Standard Test Method for Length Change of Hardened Hydraulic-Cement Mortar and Concrete*, 2017 Edition

ASTM F1554, *Standard Specification for Anchor Bolts, Steel, 36, 55, and 105-ksi Yield Strength*, 2017e1 Edition

Brick Industry Association
(formerly Brick Institute of America)
1850 Centennial Park Dr # 301,
Reston, VA 20191
<http://www.gobrick.com/>

BIA Technical Note 18, *Volume Changes – Analysis and Effects of Movement*, 2006 Edition

BIA Technical Note 18A, *Accommodating Expansion of Brickwork*, 2006 Edition

BIA Technical Note 28B, *Brick Veneer/Steel Stud Walls*, 2005 Edition

Cold Regions Research and Engineering Laboratory
72 Lyme Road
Hanover, New Hampshire
<http://www.erdc.usace.army.mil/Locations/ColdRegionsResearchandEngineeringLaboratory.aspx>

Database and Methodology for Conducting Site Specific Snow Load Case Studies for the United States

Electric Power Research Institute
3420 Hillview Avenue
Palo Alto, California 94304 USA
<http://epri.com>

EPRI Report NP-5223, *Generic Seismic Ruggedness of Power Plant Equipment* (Revision 1), 1 August 1991

Institute of Electrical and Electronics Engineers (IEEE)
445 Hoes Lane
Piscataway, NJ 08854-4141
<http://standards.ieee.org>

IEEE 693, *Recommended Practices for Seismic Design of Substations*, 2005 Edition

IEEE Standards Association, *National Electric Safety Code (NESC)*, 2017 Edition

International Code Council
500 New Jersey Ave.
NW, 6th Floor
Washington, DC 20001
<http://www.iccsafe.org/>

International Building Code, 2018 Edition

International Code Council
ICC Evaluation Service
3060 Saturn St. #100
Brea, CA 92821
<http://www.icc-es.org/>

ICC 300, *Standard for Bleachers, Folding and Telescopic Seating and Grandstands*, 2017 Edition

ICC 500, *ICC/NSSA Standard for the Design and Construction of Storm Shelters*, 2014 Edition

ICC-ES AC156, *Acceptance Criteria for Seismic Qualification by Shake-Table Testing of Nonstructural Components*, November 2010

ICC-ES AC 368, *Acceptance Criteria for Suspended Ceiling Framing Systems*, February 2012

ICC-ES AC509, *Acceptance Criteria for 3D Automated Construction Technology for 3D Concrete Walls*
June 2019/1/

McGraw-Hill
1221 Avenue of the Americas
New York, NY 10020-1095
<http://www.mhprofessional.com/>

Shock and Vibration Handbook, edited by C.M. Harris, 6th Edition, 2009

Alexander Newman, *Metal Building Systems: Design and Specification*, 2nd Edition

National Academy of Sciences
2101 Constitution Ave NW, Washington, DC 20418
<http://www.nationalacademies.org/>

Technical Report No. 65, *Expansion Joints in Buildings*, 1974 Edition

National Concrete Masonry Association
13750 Sunrise Valley Drive
Herndon, VA 20171
<http://www.ncma.org>

TEK 10-2C, *Control Joints for Concrete Masonry Walls – Empirical Method*, 2010 Edition

TEK 10-3, *Control Joints for Concrete Masonry Walls – Alternative Engineered Method*, 2003 Edition

National Fire Protection Association
1 Batterymarch Park
Quincy, MA 02169-7471
<http://www.nfpa.org>

NFPA 1, *Fire Code*, 2018 Edition

NFPA 13, *Standard for the Installation of Sprinkler Systems*, 2016 Edition

NFPA 22, *Standard for Water Tanks for Private Fire Protection*, 2018 Edition

Post-Tensioning Institute
38800 Country Club Dr, Farmington Hills, MI 48331
<http://www.post-tensioning.org/>

PTI DC10.1, *Design of Post-Tensioned Slabs-on-Ground*, 2008 Edition

PTI DC 10.5, *Standard Requirements for Design and Analysis of Shallow Post-Tensioned Concrete Foundations on Expansive Soils*, 2012 Edition

Precast/Prestressed Concrete Institute
200 West Adams Street, #2100
Chicago, IL 60606-6938

PCI MNL-122, *Architectural Precast Concrete*, 3rd Edition, 2007

PCI MNL-133, *Bridge Design Manual*, 3rd Edition

Seismic Qualification Utility Group – Winston & Strawn, EQE Incorporated, MPR Associates Incorporated, Stevenson & Associates, and URS Corporation /John A. Blume & Associates Inc.

Generic Implementation Procedure (GIP) for Seismic Verification of Nuclear Plant Equipment, Revision 3A, Volume 2 of DoE binders, 14 February 1992

320 King Street, 4th Floor Alexan-
dria, VA 22314-3238
<http://squg.mpr.com/>

Sheet Metal and Air Conditioning
Contractors' National Association
(SMACNA)
4201 Lafayette Center Drive Chan-
tilly, Virginia 20151-1219
<http://www.smacna.org/>

ANSI/SMACNA 001, *Seismic Restraint
Manual: Guidelines for Mechanical Sys-
tems*, 3rd Edition, 2008 Edition

Steel Deck Institute
2661 Clearview Rd #3, Allison Park,
PA 15101
<http://www.sdi.org/>

SDI DDM03, *Diaphragm Design Manual*,
Third Edition

Structural Engineers Association of
California
921 11th St., Suite 1100
Sacramento, CA 95814
<http://www.seaoc.org/>

SEAOC PV1-2012, *Structural Seismic Re-
quirements and Commentary for Rooftop
Solar Photovoltaic Arrays*

SEAOC PV2-2017, *Wind Design for Solar
Arrays*

Telecommunications Industry
Association (TIA)
1320 North Courthouse
Rd. Suite 200
Arlington, VA 22201
<http://www.tiaonline.org/>

ANSI/TIA-222-G, *Structural Standard for
Antenna Supporting Structures and An-
tennas*, including Addendums 1-4, Revi-
sion H, October 5, 2017

The Masonry Society
105 South Sunset St., Suite Q
Longmont, CO 80501-9215
<http://www.masonrysociety.org>

TMS 402-16, TMS 602-16, *Building Code
Requirements and Specification for Ma-
sonry Structures*

Virginia Tech
Blacksburg
VA 24061-0002
<http://www.vt.edu/>

Cynthia A. Kraus, *Floor Vibration Design
Criterion for Cold-Formed C-Shaped Sup-
ported Residential Floor systems*, Mas-
ter's Thesis, 1997

Water Environment Federation
601 Wythe Street
Alexandria, VA 22314-1304
<http://www.wef.org/>

WEF MOP 8, *Design of Municipal
Wastewater Treatment Plants*, 5th Edition

Zweigwhite
38 West Trenton Boulevard,
Suite 101
Fayetteville, AR 72701
<http://www.zweiggroup.com>

Tobolski, M., *Special Seismic Certification of Nonstructural Components*, Structural Engineering and Design, Vol. 12, No. 2, March 2011

CANCELLED

This Page Intentionally Left Blank

CANCELLED

APPENDIX B BEST PRACTICES

B-1 STRUCTURAL DESIGN.

B-1.1 Building Drift Limits.

The topic of serviceability is addressed in IBC Section 1604.3 which requires: “Structural systems and members thereof shall be designed to have adequate stiffness to limit deflections as indicated in Table 1604.3.” However, the section is obviously focused on structural members, not an entire building or structure.

ASCE 7-16 Section 12.12 requires interstory drift caused by code-prescribed seismic forces to be within tolerable limits. These are the only mandatory building drift limits of the IBC.

ASCE 7-16 Appendix C, Serviceability Considerations, which is non-mandatory, states: “Lateral deflection or drift of structures and deformation of horizontal diaphragms and bracing systems caused by wind effects shall not impair the serviceability of the structure.” The extensive commentary on this appendix discusses how the above objective might be accomplished, but leaves it to engineering judgment that should be exercised in consultation with the building client.

The establishment of acceptable drift limits and load combinations that must be considered in evaluating serviceability does require significant engineering judgment. Application of a requirement that must be stringent can significantly impact the cost of a structure. Lax requirements can lead to damage of rigidly connected components.

The *Metal Building Systems Manual* provides guidance on allowable drift due to wind loads for pre-engineered metal buildings, and serviceability recommendations for metal buildings can also be found in Chapter L of AISC 360 with additional guidance in AISC *Steel Design Guide 3*.

When separate support columns are used for top-running cranes, they should be supported so that differential movement between the crane columns and building columns, due to differences in stiffness, does not overstress either set of columns and result in local column buckling.

B-1.2 Impact Resistant Glazing.

Buildings which are subjected to tornado winds can suffer some of the same missile impact damage to the exterior façade of the building as those located in windborne debris regions. The loss of glazing on a building due to missile impact can render the facility inoperable. The loss of glazing will also cause an increase in internal pressure in the building causing further damage. Consideration should be given to providing impact resistant glazing on facilities in tornado prone areas similar to what is required in windborne debris regions. Tornado prone regions are the areas of the United States where the design wind speed for tornados in accordance with Figure 304.2(1) of ICC 500 is 250 mph.

B-1.3 Hard Wall Buildings.

In buildings constructed of load bearing tilt-up or precast structural walls, the loss of the roof diaphragm during a high wind event can lead to total collapse of the structure. The following are several possible methods to mitigate this hazard:

- Limit the length of continuous wall panels between full height lateral cross bracing elements to better restrain the wall panels.
- Provide a system of robust continuous ties across the roof diaphragm to preserve the walls if the roof diaphragm fails.

FEMA has issued an important publication, FEMA P-1026, on the seismic design of these buildings.

B-1.4 Wind and Seismic Loads on Photovoltaic Arrays.

Design provisions for rooftop-mounted photovoltaic panels and their attachments are included in ASCE 7-16 Section 13.6.12 for seismic loading and in ASCE 7-16 Chapters 29 through 31 for wind loading. Additional guidance on the design wind and seismic loads for rooftop-mounted photovoltaic arrays can be found in *Wind Design for Solar Arrays* (SEAOC PV2-2017) and *Structural Seismic Requirements and Commentary for Rooftop Solar Photovoltaic Arrays* (SEAOC PV1-2012), prepared by the Structural Engineers Association of California Solar Photovoltaic Systems Committee. When designing support structures for photovoltaic arrays, review requirements in UFC 3-110-03 *Roofing* concerning roof mounted systems including the requirement that supports be permanently affixed to the structure, which means that ballasted systems are not permitted. 2018 IBC Section 1607.13.5 includes gravity load requirements for roof structures that provide support for photovoltaic panel systems. This section does not disallow ballasted systems. Seismic design of ballasted photovoltaic panel systems is in fact specifically permitted by 2018 IBC Section 1613.3.

B-1.5 Wind Loads on Buildings with Large Openings.

When determining wind loads on building containing large openings such as overhead doors in warehouses, maintenance shops, etc., it is recommended that the criteria for hangars in Section 1609.1.2 of Chapter 2 of this UFC be used.

B-2 SOILS AND FOUNDATIONS.

B-2.1 Gable Bent Footings.

Moment frame reactions from metal building gable bents have horizontal thrusts at column bases which can be resisted by several methods. For large thrust forces (40 to 50 kips (118 kN to 222 kN)), tie rods are usually cost-effective. The tie rods can be embedded in a thickened slab or can be part of a tie beam between column foundations. For smaller thrust forces, hairpin reinforcing bars may be used to transfer the thrust force

from the column anchor bolts into the slab-on-ground reinforcement, which acts as the tie between the columns. However, each of these methods requires close attention to detailing of joints in the slab, isolation joints around a foundation pier and other possible interruptions in the continuous slab reinforcement between columns. Also, future renovations that might require trenching across the continuous slab reinforcement could result in the loss of the tension tie. A third method must design the foundation for an overturning moment due to the thrust force at the base of the column. Each of these methods can provide the necessary resistance to the thrust force, but needs to be evaluated for each project condition. For further discussion on the design of foundations for gable bent reactions, refer to *Metal Building Systems: Design and Specification* by Alexander Newman.

B-2.2 Footings on Expansive Soils.

In the presence of expansive soils, footings must be designed to withstand expansive soil movement in order to prevent significant damage to structures. Cyclical expansive soil movement from soil water content, usually caused by a combination of inadequate drainage and seasonal wetting and drying cycles, are especially troublesome. Base the design on soil testing and recommendations by qualified geotechnical engineers. Ensure soil investigations include estimates of settlement, heave, and recommendations to mitigate effects of expansive soil movement. Ensure positive drainage away from structures that will prevent ponding close to structures. Guidance on design of foundations on expansive soils can be found in UFC 3-220-01 and PTI DC 10.5-12.

B-2.3 Footing Depth Due to Frost.

The depth to which frost penetrates at a site depends on the climate, the type of soil, the moisture in the soil and the surface cover (e.g., pavement kept clear of snow vs. snow covered turf). If the supporting soil is warmed by heat from a building, frost penetration is reduced considerably. The values in the WBDG load data tool (<https://www.wbdg.org/additional-resources/tools/ufcsltdt>) represent the depth of frost penetration to be expected if the ground is bare of vegetation and snow cover, the soil is non-frost susceptible (NFS), well-drained (i.e., dry) sand or gravel, and no building heat is available. Thus, these values represent the deepest (i.e., worst case) frost penetration expected in each area. Most building foundations can be at a shallower depth without suffering frost action. (However, other considerations besides frost penetration may affect foundation depth, such as erosion potential or moisture desiccation). For interior footings, which under service conditions are not normally susceptible to frost, the potential effects of frost heave during construction should be considered. Design values for heated and unheated buildings may be obtained by reducing the values WBDG tool values according to Figure B-1. For buildings heated only infrequently, the curve in Figure B-1 for unheated buildings should be used. The curves in Figure B-1 were established with an appreciation for the variability of soil and the understanding that some portions of the building may abut snow-covered turf while other portions abut paved areas kept clear of snow. Foundations should be placed at or below the depths calculated above. The foundation of heated buildings may be placed at a shallower depth than calculated above if protected from frost action by insulation on the cold side, see Figure C1 of

ASCE 32. For more information on the design of foundation insulation, see ASCE 32. Additional information on which more refined estimates of frost penetration can be made, based on site-specific climatic information, the type of ground cover, and soil conditions, is contained in UFC 3-130-06.

Figure B-1 Footing Depth Example: The minimum depth needed for footings of a hospital and an unheated vehicle storage building to be built in Fort Drum, New York, is calculated to protect them from frost action. The tabulated frost penetration value for Fort Drum is 94 inches (WBDG load data tool). Using the “heated” curve in Figure B-1, footings for the hospital should be located 4 feet below the surface. Using the “unheated” curve, footings for the unheated garage should be located 5.5 feet below the surface.

B-3 CONCRETE.

B-3.1 Slab-on-Ground Concrete Strength.

For slabs-on-ground subject to forklift traffic, it is recommended that the minimum compressive strength for the concrete be 4,000 psi (27.6 MPa) for pneumatic tire traffic and 5,000 psi (34.5 MPa) for steel tire traffic.

B-3.2 Slab-on-Ground Joints.

For slabs-on-ground, it is recommended that the joints align across the building floor plate to avoid joints ending abruptly at the edge of a panel. Joints that end abruptly at an adjacent panel edge could cause a crack to propagate into the adjacent panel. For locations where placement of joints at a panel edge are unavoidable, refer to UFC 3-320-06A for additional reinforcement requirements to minimize crack propagation.

Location of joints in slabs-on-ground need to be coordinated with the joints in hard-surface finishes to avoid having the joints telegraph through the hard-surface finish.

B-3.3 Slab-on-Ground Drying Shrinkage.

Cracking in slabs generally results from drying shrinkage and restraint caused by friction between the slab and subgrade. Curling and warping occur due to differential shrinkage when the top of the slab dries to lower moisture content than the bottom of the slab. Recommendations for reducing the effects of drying shrinkage can be found in ACI 360R, ACI 224R, and ACI 302.1R. Shrinkage compensating concrete can also be used to reduce shrinkage cracking. See recommendations in ACI 223R.

Figure B-1 Design Depth of Bottom of Building Foundation

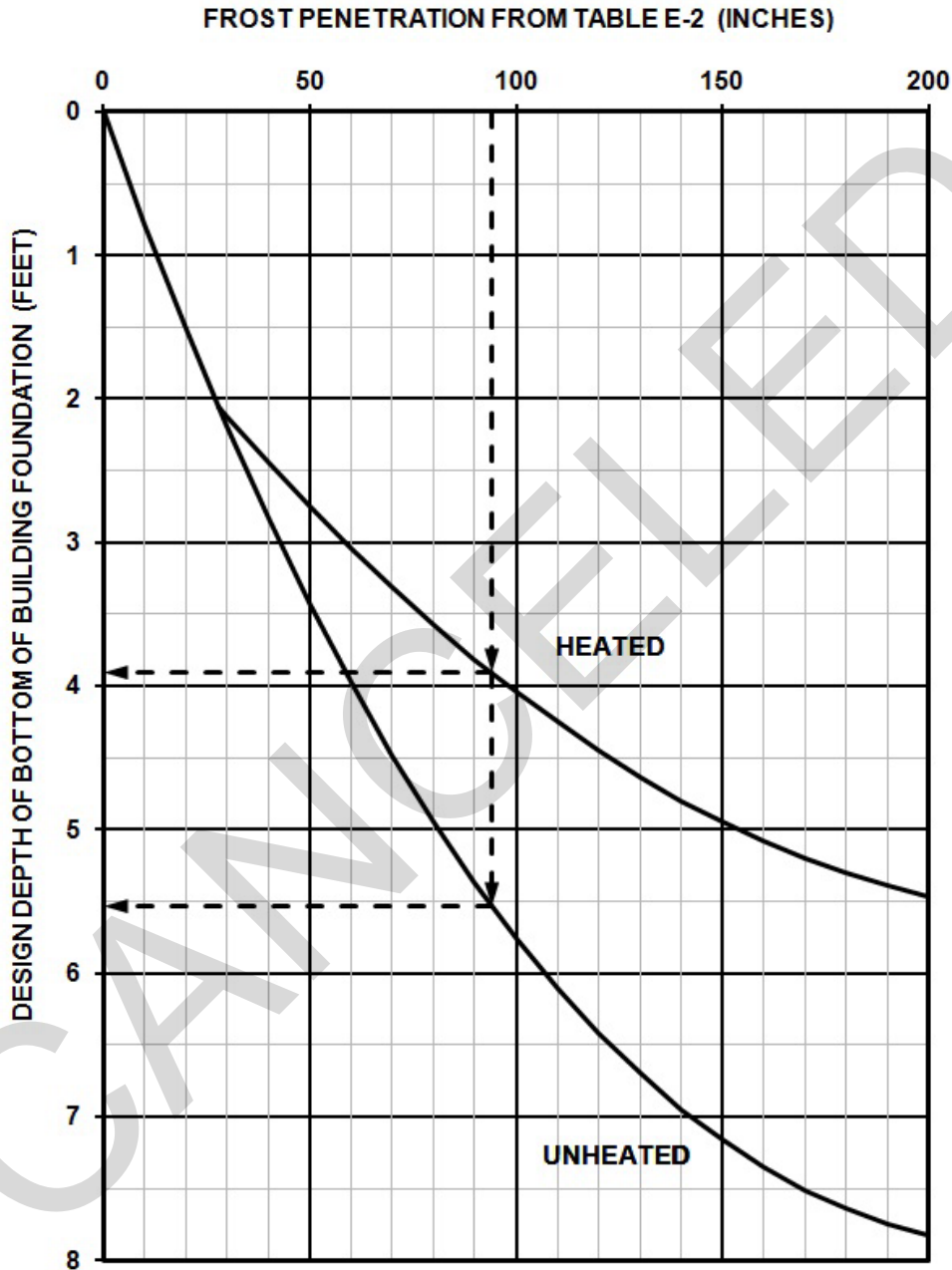

B-3.4 Slab-on-Ground Vapor Retarder/Barrier.

To facilitate proper moisture control of a slab-on-ground to meet the moisture limits of water-based adhesives and durability during construction, it is recommended that the vapor retarder have a minimum thickness of 10 mil (250 μm) with a maximum permeance rating of 0.04 perm. Where moisture is a critical issue under the floor covering, such as wood floors, and a vapor barrier is required, it is recommended to reduce the

maximum permeance rating to 0.01 perm. For further guidance on slabs to receive moisture-sensitive floor coverings refer to ACI 302.2R. Note that the 2018 IBC has minimum vapor barrier requirements in Section 1907.

B-3.5 Post-Installed Adhesive Concrete Anchors.

It is recommended that adhesive anchors be proof loaded during special inspections of critical anchors to the lesser of 50 percent of the expected peak load based on adhesive bond strength or 80 percent of the anchor yield strength with the proof load being sustained for a minimum of 10 seconds.

B-4 MASONRY.

B-4.1 Masonry Veneer Base Detail.

The base of the masonry veneer should be placed on a shelf angle or a foundation ledge that is lower than the base of the steel stud wall by at least 4 inches (102 mm). The width of this shelf angle or foundation ledge will include the width of the masonry veneer and the cavity. This width should not be less than two-thirds of the veneer thickness plus the minimum air space.

B-5 STEEL.

B-5.1 Shelf Angles for Masonry.

Shelf angles should be hot-dip galvanized structural steel members. Angles should be provided in segments approximately 10 feet (3 m) in length, with gaps between segments. Shelf angles should be detailed to allow enough gaps for thermal expansion and contraction of the steel in angle runs and at building corners. Corners of buildings should have corner pieces with each leg no less than 4 feet (1.2 m) in length where possible.

Limit deflection of horizontal legs of shelf angles under masonry loading to 1/16 inch (1.6 mm) at the end of the horizontal leg. Rotation of the shelf angle support should be included in the horizontal leg displacement calculation.

B-5.2 Cold-Formed Continuous Beams and Joists.

Guidance on determining the effective length of the unbraced compression flange for cold-formed continuous beams and joists can be found in AISI *Effective Lengths for Laterally Unbraced Compression Flanges of Continuous Beams Near Intermediate Supports*.

B-5.3 Masonry Veneer/Steel Stud Wall Detailing.

Recommended details for masonry veneer/steel stud wall assemblies can be found in BIA Technical Note 28B.

B-5.4 Steel Structures in Corrosive Environments.

Steel structures designed for corrosive environments should include consideration of the following corrosion protection measures:

- a. Box-shaped members should be designed so that all inside surfaces may be readily inspected, cleaned, and painted, or should be closed entirely, except when hot-dip galvanized, to prevent exposure to moisture.
- b. The legs of two back-to-back angle members, when not in contact, should have a minimum separation of 3/8 inch (9.5 mm) to permit air circulation.
- c. Pockets or depressions in horizontal members should have drain holes to prevent water from ponding in low areas. Positive drainage should be provided away from exposed steel. Column bases should be terminated on concrete curbs or piers above grade, and tops of curbs or piers should be pitched to drain.
- d. Where extremely corrosive conditions exist, consideration should be given to providing cathodic protection in addition to protective coatings for steel members exposed to salt water moisture environments.
- e. Structural members embedded in concrete and exterior railing, handrails, fences, guardrails, and anchor bolts should be galvanized or constructed of stainless steel.
- f. Dissimilar metals, (e.g., aluminum and steel, stainless steel and carbon steel, zinc-coated steel and uncoated steel) should be isolated by appropriate means to avoid the creation of galvanic cells which can occur when dissimilar metals come in contact.
- g. Consult a corrosion specialist certified by NACE International to recommend material protection for elements exposed to heavy industrial pollution, chemicals, or corrosive soils.
- h. For increased serviceability and compatibility with fireproofing, use galvanized steel deck in accordance with ASTM A653/A653M.
- i. Note that some common grades of stainless alloy such as ASTM Type 306 or 316 are susceptible to corrosion when immersed in salt or brackish water.

Further guidance for designing steel structures in corrosive environments can be found in *ASM Handbook Volume 13B*.

B-5.5 Steel Structures in Arctic and Antarctic Zones.

For carbon steel, the transition from ductile to brittle behavior occurs within temperatures to be expected in Arctic and Antarctic zones. Ductility is important for structures in high seismic areas. Toughness, a characteristic also affected by cold temperatures, is important for structures which could be subjected to cyclic or impact loads. Design of structures which could be subjected to cyclic or impact loads in cold climates should include consideration of the following measures to mitigate potential fatigue and fracture problems:

- a. Provide ample fillets to avoid stress risers.
- b. Use bolted joints whenever possible. If welded joints are used, take precautions to eliminate gas and impurities in welds. Proper preheating and post-cooling are essential.
- c. Use low-carbon steels and nickel-alloy steels that have good toughness characteristics at low temperatures.

B-5.6 Steel Column Base Plate Shear Transfer.

Shear transfer between column base plates and the concrete foundation elements can be accomplished through several load paths including shear friction between the base plate and grout, anchor rods or shear keys. The design provisions in *AISC Design Guide 1: Base Plate and Anchor Rod Design* should be followed when designing base plates for shear. Research and full scale testing of base plates in shear, conducted at the University of California, Berkeley, provide further guidance on recommended shear friction coefficient, anchor rod bending length, and concrete capacity design of shear key bearing. Results of the testing can be found in the research report *Shear Transfer in Exposed Column Base Plates*, published by AISC.

B-5.7 Steel Joist Connections.

Connections between open web steel joists and supporting girders or joist girders and building columns are in many instances covered by typical details provided by the joist supplier, which may not provide the needed capacity for lateral or uplift loading. Each joist connection should be designed specifically for the project and take into consideration the lateral and uplift loads acting on the connection.

B-6 WOOD.

B-6.1 Connections.

When using prescriptive guidelines in building codes for nailed wood connections, careful consideration needs to be given to ensure a complete load path from the roof to the foundation. The use of metal plate connections for roof trusses, top plates and sill plates is an effective way to provide a more robust load path.

APPENDIX C ALTERNATE DESIGN PROCEDURE FOR RC IV STRUCTURES

C-1 GENERAL.

C-1.1 Overview.

This Appendix must be used for the alternate design of buildings and other structures assigned to RC IV.

Buildings assigned to RC IV are either unit/installation-essential or post-disaster essential (Table 2-2). This Appendix provides an optional nonlinear static and nonlinear dynamic analysis procedure for RC IV buildings and other structures that may be used as an alternative to the procedures found in the 2018 *International Building Code* (2018 IBC). This procedure may provide more economical or better-performing structural designs compared to linear analysis procedures. The analysis procedures outlined in this Appendix must be used only with the approval of the Authority having Jurisdiction.

The nonlinear procedures outlined in this Appendix require that an RC IV building meet two general performance objectives:

1. A Life Safety (LS) performance objective for the Risk-Targeted Maximum Considered Earthquake (MCE_R) ground motions, nominally an earthquake associated with a 1% probability of structural collapse in 50 years; and,
2. An Immediate Occupancy (IO) performance objective for earthquake ground motion that is two-third of the MCE_R ground motion. This earthquake is termed herein as the BSE-1N earthquake, adopting the terminology used in ASCE/SEI 41-17, *Seismic Evaluation and Retrofit of Existing Buildings*.

[C] C-1.1 Overview

In ASCE 7-16, MCE_R is used in conjunction with a “Collapse Prevention” performance objective. The alternate design in this chapter is required to meet a “Life Safety” performance objective. So, from a purist point of view, the procedure in this Appendix should have used MCE ground motion values, which could be determined by dividing the S_S - and S_1 - values of ASCE 7-16, by risk coefficients C_{RS} (ASCE 7-16 Figure 22-18) and C_{R1} (ASCE 7-16 Figure 22-19), respectively. In view of the fact that C_{RS} - and C_{R1} -values are typically within a narrow range around 1.0, a decision was made to avoid unjustifiable complications and use MCE_R ground in place of MCE ground motion for the alternate designs of this Appendix. The same approach is adopted in ASCE 41-13 as well.

Performance criteria based on tolerable levels of damage are defined to ensure that these performance objectives are met. Nonlinear strength and deformation demands are determined by performing nonlinear static or nonlinear dynamic analyses and the

results compared with acceptance criteria contained in authoritative documents, such as ASCE 41-13 or FEMA P-750, or developed based on laboratory data or rational analysis.

To ensure that satisfactory nonlinear behavior is achieved, restrictions on the types of seismic force-resisting systems that can be used in conjunction with this Appendix are imposed.

This Appendix replaces the provisions of Chapter 16 of the 2018 IBC, as modified by Chapter 2, for use in performing the alternative analysis of RC IV buildings and other structures. All other chapters of the 2018 IBC apply as modified by Chapter 2.

C-1.2 Design Review Panel.

A design review of the seismic force-resisting system design and structural analysis must be performed by an independent team of Registered Design Professionals in the appropriate disciplines and others experienced in seismic analysis methods and the theory and application of nonlinear seismic analysis and structural behavior under extreme cyclic loads. In addition to a final review, a Design Review Panel should be convened at the beginning of a design to review proposed design methodology and strategy. Membership on the Design Review Panel is subject to the approval of the Authority having Jurisdiction. A design review needs to include, but not necessarily be limited to, the following:

1. Any site-specific seismic criteria used in the analysis, including the development of site-specific spectra and ground motion time-histories;
2. Any acceptance criteria used to demonstrate the adequacy of structural elements and systems to withstand the calculated force and deformation demands, together with any laboratory or other data used to substantiate the criteria;
3. The preliminary design, including the selection of the structural system and the configuration of structural elements; and,
4. The final design of the entire structural system and all supporting analyses.

C-2 DEFINITIONS.

C-2.1 General.

2018 IBC Section 202 and ASCE 7-16 Section 11.2 apply. In addition, the definitions listed in Section X.1 of Resource Paper 2 of FEMA P-750, *NEHRP Recommended Provisions for Seismic Regulations for New Buildings and Other Structures*, 2009 Edition, apply.

C-3 CONSTRUCTION DOCUMENTS.

C-3.1 General.

2018 IBC Section 1603, as modified by Section 2-4.1 of this UFC, applies.

Exception:

For buildings designed using this Appendix, the Seismic Importance Factor, I_e , the design base shear, seismic response coefficient, C_s , and the Response Modification Factor, R , do not apply and need not be listed in construction documents.

C-4 GENERAL DESIGN REQUIREMENTS.

C-4.1 General.

2018 IBC Section 1604 applies, except as modified herein. Table 2-2 of this UFC must replace 2018 IBC Table 1604.5. The Importance Factor for seismic loading defined in Table 2-2 does not apply, and should be taken as 1.0. Importance Factors for seismic design of nonstructural components must be determined in accordance with the criteria of ASCE7-16 Chapter 13. Importance Factors for snow and ice loads apply as listed in Table 2-2.

C-5 LOAD COMBINATIONS.

C-5.1 General.

RC IV buildings and other structures, and portions thereof, must be designed to resist the load combinations specified in this section. For all load combinations where earthquake-generated forces are not considered, 2018 IBC Section 1605.2 applies. In addition, where atmospheric ice and wind-on-ice loads are considered, ASCE 7-16 Section 2.3.3 applies. Where earthquake-generated forces are considered, 2018 IBC Equations 16-5 and 16-7 must be replaced by Equations C-1 and C-2 of this UFC. 2018 IBC Section 1605.3 does not apply; allowable stress design is not permitted for use in this Appendix. ASCE 7-16 Section 2.3.6 does not apply; for any design situation requiring the use of load combinations with overstrength factor, Equations C-1 and C-2 apply, subject to the exceptions noted in Section C-18.1.

C-5.2 Seismic Load Combinations.

When the effects of earthquake-generated forces are considered, structures are required to resist the most critical effects from the following combinations of factored loads:

When the effects of gravity and seismic loads are additive:

$$1.1(D + 0.25 L + 0.2 S) + E \quad \text{(Equation C-1)}$$

When the effects of gravity and seismic loads are counteractive:

$$0.9 D + E$$

(Equation C-2)

Where

D = Effect of dead load

L = Effect of unreduced design live load

S = Effect of design flat roof snow load calculated in accordance with ASCE 7-16

E = The maximum effect of horizontal and vertical earthquake forces at the BSE-1N displacement (Δ_S) or MCE_R displacement (Δ_M), determined in the nonlinear analysis, as set forth in Section C-18.1

Exception: Where the design flat-roof snow load calculated in accordance with ASCE 7-16 is less than 30 psf, the effective snow load is permitted to be taken as zero.

C-6 DEAD LOADS.

C-6.1 General.

2018 IBC Section 1606 applies.

C-7 LIVE LOADS

C-7.1 General.

2018 IBC Section 1607, as modified by Section 2-4.3 of this UFC, applies, except that wherever Table 1607.1 is referenced, it must be replaced by Table G-1 of this UFC.

C-8 SNOW LOADS.

C-8.1 General.

2018 IBC Section 1608, as modified by Section 2-4.4 of this UFC, applies.

C-9 WIND LOADS.

C-9.1 General.

2018 IBC Section 1609, as modified by Section 2-4.5 of this UFC, applies.

C-10 SOIL LATERAL LOADS.

C-10.1 General.

2018 IBC Section 1610 applies, without the exception that is noted there.

C-11 RAIN LOADS.

C-11.1 General.

2018 IBC Section 1611 applies.

C-12 FLOOD LOADS.

C-12.1 General.

2018 IBC Section 1612 applies.

C-13 ICE LOADS—ATMOSPHERIC ICING.

C-13.1 General.

2018 IBC Section 1614 applies.

C-14 TSUNAMI LOADS.

C-14.1 General.

Probabilistic Tsunami Hazard Analysis (PTHA) may be performed on either the current topography or the topography adjusted for sea-level rise. Use current NAVD88/MHW still water elevation for EGL velocity calculations regardless of topography used for PTHA.

C-15 EARTHQUAKE LOADS – GENERAL.

C-15.1 Scope.

Every structure, and portion thereof, must as a minimum be designed and constructed to resist the effects of earthquake motions and assigned an SDC as set forth in 2018 IBC Section 1613.2.5/ASCE 7-16 Section 11.6. The use of nonlinear analysis procedures in this Appendix minimizes the need for SDC use, but the SDC is required for establishing detailing requirements.

C-16 EARTHQUAKE LOADS – SITE GROUND MOTION.

C-16.1 General Procedure for Determining Design Spectral Response Accelerations.

Ground motion accelerations, represented by response spectra and coefficients derived from these spectra, must be determined in accordance with the general procedure of this Section, or the site-specific response analysis procedure of Section C-16.2.

Mapped spectral response accelerations must be determined as prescribed in Sections 1613.2.1.1 and 1613.2.1.2 in Chapter 2 of this UFC.

MCE_R spectral accelerations, adjusted for site class effects, at short periods (S_{MS}) and 1-second period (S_{M1}) must be determined in accordance with ASCE 7-16 Section 11.4.4. The general response spectrum for MCE_R ground shaking must be determined

in accordance with ASCE 7-16 Section 11.4.6, except that S_{MS} and S_{M1} must be used respectively in lieu of S_{DS} and S_{D1} .

The BSE-1N spectral accelerations, adjusted for site class effects, at short periods (S_{DS}) and at 1-second period (S_{D1}) must be determined as 2/3 of S_{MS} and S_{M1} , respectively. The design response spectrum for BSE-1N ground shaking must be constructed in accordance with ASCE 7-16 Section 11.4.6.

C-16.1.1 Site Class Definition.

ASCE 7-16 Section 20.3 applies as written.

C-16.2 Site-specific Response Analysis for Determining Ground Motion Accelerations.

ASCE 7-16 Section 21.1 applies.

C-16.3 Ground Motion Hazard Analysis.

ASCE 7-16 Section 21.2 applies.

C-17 EARTHQUAKE LOADS – CRITERIA SECTION.

C-17.1 Structural Design Criteria.

Each structure must be assigned a Seismic Design Category in accordance with 2018 IBC Section 1613.2.5/ASCE 7-16 Section 11.6, for use with required structural design and construction provisions. Each structure must be provided with complete lateral and vertical force-resisting systems capable of providing adequate strength, stiffness, and energy dissipation capacity to withstand the earthquake ground motions determined in accordance with Section C-16 within the prescribed performance objectives of Section C-18. In addition, each structure must be designed to accommodate the architectural, mechanical, and electrical component requirements of Section C-22. Ground motions must be assumed to occur along any horizontal direction of a structure. A continuous load path, or paths, with adequate strength and stiffness to transfer forces induced by the earthquake ground motions from the points of application to the final point of resistance must be provided.

C-17.2 Importance Factors.

The structural seismic importance factor, I_e , is not used. The component seismic importance factor, I_p , used in Section C-22, must be the value specified in Sections C-22.4.4.

C-17.3 Site Limitations.

A structure assigned to RC IV must not be sited where there is a known potential for an active fault to cause rupture of the ground surface at the structure. An *active fault* is defined as a fault for which there is an average historic slip rate of 1 mm or more per year and for which there is geographic evidence of seismic activity in Holocene times (the most recent 11,000 years).

C-17.4 Building Configuration.

The requirements of ASCE 7-16 Sections 12.3.1, 12.3.2, and 12.3.3 do not apply to facilities designed using the provisions of this Chapter.

C-17.5 Analysis Procedures.

C-17.5.1 Nonlinear Analysis.

The Alternate RC IV analysis procedure of this Appendix may be used in lieu of the Equivalent Lateral Force or Modal Response Spectrum Analysis procedures that would generally be used to comply with the 2018 IBC and Chapter 2 of this UFC. For this alternate procedure, a nonlinear structural analysis must be performed. The analysis may use either the Nonlinear Static Procedure (NSP) or the Nonlinear Dynamic Procedure (NDP).

C-17.5.1.1 Nonlinear Static Procedure.

The NSP is permitted for structures not exceeding 6 stories in height and having a fundamental period, T , not greater than $3.5T_s$, where T_s is determined in accordance with ASCE 7-16 Section 11.4.6. Application of the NSP needs to comply with the requirements of *Resource Paper 2 of FEMA P-750, NEHRP Recommended Provisions for Seismic Regulations for New Buildings and Other Structures, 2009 Edition, Part 3, Resource Papers (RP) on Special Topics in Seismic Design, subject to the modifications below*. In applying the NSP, the user may employ the references cited in Resource Paper 2 of FEMA P-750. Further information on NSP may be found in *FEMA P-750, NEHRP Recommended Provisions for Seismic Regulations for New Buildings and Other Structures, 2009 Edition, Part 2, Commentary* and in NEHRP Seismic Design Technical Brief No. 4, *Nonlinear Structural Analysis for Seismic Design*, NIST GCR 10-917-5. The following should be noted:

1. To apply the FEMA P-750 NSP, the design earthquake ground motions and associated spectral accelerations must be as specified herein (MCE_R and BSE-1N), and not the design ground motions defined in FEMA P-750.
2. A target displacement must be separately determined for each of the MCE_R and BSE-1N spectra.

3. The structure as a whole and each of the elements of the lateral force-resisting system and its connections must be evaluated for their adequacy to provide Immediate Occupancy Performance at the BSE-1N target displacement and to provide Life Safety Performance at the MCE_R target displacement.
4. P-Delta effects must be included in the development of the backbone curves (see Section 2.4 of NIST GCR 10-917-5 NEHRP Seismic Design Technical Brief No 4).
5. Multidirectional and concurrent seismic effects must be included as defined in Section 7.2.5 of ASCE/SEI 41-17.
6. The following modifications must be made to Resource Paper 2 of FEMA P-750
 - a. Replace references to ASCE 41-06 w/Supplement 1 with ASCE/SEI 41-17.
 - b. Replace references to Section 3.3.3 of ASCE 41-06 w/Supplement 1 with Section 7.4.3 of ASCE/SEI 41-17.
 - c. Replace references to Section 3.3.3.3.2 of ASCE 41-06 w/Supplement 1 with Section 7.4.3.3.2 of ASCE/SEI 41-17.
 - d. Replace reference to Equation 3-16 of ASCE/SEI 41-06 w/Supplement 1 with Equation 7-32 of ASCE/SEI 41-17 and replace μ_{max} in Equation 7-32 of ASCE/SEI 41-17 with R_{max} .

C-17.5.1.2 Nonlinear Dynamic Procedure.

Application of the NDP needs to comply with the requirements of ASCE 7-16 Chapter 16.

C-17.5.2 Site Ground Motions.

Two characteristic ground motions must be required for the design of facilities using this procedure:

1. For the LS performance objective, the MCE_R ground motion must be used. For the NSP, spectral response accelerations must be determined using the procedures of Section C-16.1 or Section C-16.2. For the NDP, MCE_R ground motions must be determined using procedures prescribed in ASCE 7-16 Section 16.2.
2. For the IO performance objective, the BSE-1N ground motion must be used. For the NSP, spectral response accelerations must be determined using the procedures of Section C-16.1 or Section C-16.2. For the NDP, BSE-1N ground motions must be determined using procedures prescribed in ASCE 7-16 Section 16.2.

C-18 EARTHQUAKE LOADS – MINIMUM DESIGN LATERAL FORCE AND RELATED EFFECTS.

C-18.1 Seismic Load Effect, E .

When the NSP is used, the seismic load effect, E , for use in the load combinations of Section C-5.2 must be determined from ASCE 7-16 Section 12.4. In the application of ASCE 7-16 Section 12.4, the term S_{DS} must be interpreted as S_{MS} for the LS performance objective. When the NDP is used, the seismic load effect, E , is simply the response determined from the dynamic analysis. The redundancy coefficient, ρ , must be taken as 1.0.

Exceptions:

1. Where these provisions require consideration of structural overstrength (see ASCE 7-16 Section 12.4.3), the values of member forces, Q_E , obtained from NSP analysis at the peak (maximum base shear) of the NSP pushover curve must be used in place of the quantity E_{mh} .
2. Where these provisions require consideration of structural overstrength (see ASCE 7-16 Section 12.4.3), the values of member forces, Q_E , obtained from NDP analysis at the maximum base shear found in the analysis using any of the ground motion records must be used in place of the quantity E_{mh} .

C-18.2 Redundancy.

ASCE 7-16 Section 12.3.4 does not apply to facilities designed using the provisions of this Chapter.

C-18.3 Deflection and Drift Limits.

C-18.3.1 Allowable Story Drift.

Because the Alternate Design Procedure is a nonlinear performance-based design approach, specific target drift limits are not set for designs.

C-18.3.1.1 Life Safety Performance Objective.

The LS performance objective must be achieved for MCE_R ground shaking. At the LS performance level, structural components may be damaged, but they retain a margin of safety of at least 1.5 against the onset of loss of gravity load carrying capacity. Some residual global structural strength and stiffness remain at the maximum lateral displacement in all stories. No out-of-plane wall failures occur. Partitions may be damaged, and the building may be beyond economical repair. Some permanent (inelastic) drift may occur. While inelastic behavior is permitted, member strength degradation needs to be limited in primary structural members (residual strength cannot not be less than 80% of

nominal yield strength). Primary structural elements are those that are required to provide the building with an ability to resist collapse when ground motion-induced seismic forces are generated. For secondary structural elements (those that are not primary elements), strength degradation to levels below the nominal yield strength is permitted. Not more than 20% of the total strength or initial stiffness of a structure can be assumed to be provided by secondary elements. The LS performance objective needs to be verified by analysis - either the NSP or the NDP. LS acceptance criteria contained in ASCE 41-13 must be used to demonstrate acceptable performance. Alternatively, acceptance criteria can be developed by the designer and approved by the design review panel (see Section C-1.2)

C-18.3.1.2 Immediate Occupancy Performance Objective.

The IO performance objective must be achieved for BSE-1N ground shaking. At the IO performance level, a building remains safe to occupy, essentially retaining pre-earthquake design strength and stiffness and nonstructural elements retain position and are operational. Minor cracking of facades, ceilings, and structural elements may occur. Significant permanent (inelastic) drift does not occur. The structural system for the building remains “essentially” elastic. Any inelastic behavior does not change the basic structural response and does not present any risk of local failures. Member deformations are not permitted to exceed 125% of deformations at nominal member yield strengths. No member strength degradation is permitted, regardless of deformation. The IO performance objective needs to be verified by analysis, either the NSP or the NDP. The IO acceptance criteria contained in ASCE 41-13 must be used to demonstrate acceptable performance (see ASCE 41-13 Table 2-3 BPON Performance 1-A). Alternatively, appropriate acceptance criteria can be developed by the designer and approved by the design review panel (see Section C-1.2)

C-18.3.2 Drift Determination and P-Delta Effects.

C-18.3.2.1 Drift and Deflection Determination for Nonlinear Static Procedure.

The design story drifts, Δ_S and Δ_M must be taken as the values obtained for each story at the target displacements for the BSE-1N and MCE_R , respectively.

C-18.3.2.2 Drift and Deflection Determination for Nonlinear Dynamic Procedure.

Story drifts must be determined directly from the nonlinear analysis performed in accordance with the provisions of ASCE 7-16 Chapter 16.

C-18.3.2.3 P-Delta Effects for Nonlinear Static Procedure and Nonlinear Dynamic Procedure.

Static P-Delta ($P-\Delta$) effects must be incorporated in all lateral load analyses.

C-18.4 Seismic Force-resisting Systems.

C-18.4.1 Permitted Seismic Force-resisting Systems.

Table C-1, System Limitations for RC IV Buildings Designed Using Alternate Analysis Procedure, must replace ASCE 7-16 Table 12.2-1 and Table 3-1 of this UFC. Table C-1 must be used to determine whether a seismic force-resisting system is permitted. Table C-1 also lists building height limitations for the permitted systems. Seismic force-resisting systems that are not listed in Table C-1 may be permitted if analytical and test data are submitted that establish the dynamic characteristics and demonstrate the lateral force resistance and energy dissipation capacity to be equivalent to the structural systems listed in the table. Such exceptions may be authorized when permission is granted by the design review panel (see Section C-1.2).

C-18.4.2 Structural Design Requirements.

C-18.4.2.1 Dual Systems.

ASCE 7-16 Section 12.2.5.1 applies.

C-18.4.2.2 Combinations of Framing Systems.

Different seismic force-resisting systems are permitted along the two orthogonal axes of a building structure, so long as both systems comply with the provisions of this Chapter.

C-18.4.2.3 Interaction Effects.

Moment-resisting frames that are enclosed or adjoined by more rigid elements that are not considered to be part of the seismic force-resisting system must be designed so that the action or failure of those elements will not impair the vertical load-carrying and seismic force-resisting capability of the frame. The design needs to provide for the effect of these rigid elements on the structural system at structural deformations corresponding to the design story drift at the target displacement, as determined by analysis.

C-18.4.2.4 Deformational Compatibility.

For components that are not included in seismic force resisting system ensure that ductile detailing requirements are provided such that the vertical load-carrying capacity of these components is not compromised by induced moments and shears resulting from the design story drift.

For structures assigned to Seismic Design Category D, E, or F, reinforced concrete frame members not designed as part of the seismic force-resisting system must comply with ACI 318 *Building Code Requirements for Structural Concrete*, Section 18.14.

C-18.4.3 Response Modification (R), System Overstrength (Ω_0), Deflection Amplification (C_d) Factors.

Because only the NDP or the NSP are permitted for the alternate design of RC IV structures the factors R , C_d , and Ω_0 are not required.

C-18.4.4 Member Strength.

The load combination requirements of Sections C-5.1 and C-5.2 must be satisfied. Seismic load effects must be determined in accordance with Section C-18.1.

C-19 DYNAMIC ANALYSIS PROCEDURES FOR THE SEISMIC DESIGN OF BUILDINGS.

C-19.1 General.

The procedures outlined in Section C-17.5 must be followed for dynamic analysis of buildings and other structures that are designed in accordance with the provisions of this Chapter.

C-20 EARTHQUAKE LOADS, SOIL-STRUCTURE INTERACTION EFFECTS.

C-20.1 Analysis Procedure.

When these effects are considered, the provisions of ASCE 7-16 Chapter 19 apply.

C-21 SEISMIC DESIGN, DETAILING, AND STRUCTURAL COMPONENT LOAD EFFECTS.

C-21.1 Structural Component Design and Detailing.

The provisions of ASCE 7-16 Chapter 12, as modified by Chapter 3 of this UFC, apply.

C-21.2 Structural Integrity.

The provisions of 2018 IBC Section 1616 apply.

C-21.3 Soils and Foundations.

The provisions of 2018 IBC Chapter 18 apply.

C-22 SEISMIC DESIGN REQUIREMENTS FOR NONSTRUCTURAL COMPONENTS.

C-22.1 Component Design.

The provisions of ASCE 7-16 Chapter 13, as modified by Chapter 3, apply, except as noted in the following paragraphs. Appendix D provides supplementary guidance on design and analysis of some architectural, mechanical, and electrical components.

C-22.2 Performance Objectives.

The design procedure presented in this Appendix includes two overall performance objectives that influence the requirements for architectural, mechanical, and electrical components. First, the design must provide LS performance for the MCE_R . Second, the design must provide IO performance for BSE-1N ground motions.

C-22.2.1 Life Safety Performance Objective for Nonstructural Components.

This performance level seeks to mitigate falling hazards, but many architectural, mechanical, and electrical systems may be damaged and become non-functional.

C-22.2.2 Immediate Occupancy Performance Objective for Nonstructural Components.

This performance level ensures that installed equipment and contents remain mounted to their supporting system and remain functional, but the equipment may not be operational due to loss of utilities.

C-22.3 Modification of ASCE 7-16 for Life Safety Design.

C-22.3.1 Ground Motion Parameters for Determination of Life Safety Seismic Forces.

In the application of ASCE 7-16 Section 13.3.1, seismic forces must be determined for the MCE_R ground motion parameters.

C-22.3.2 Nonlinear Static Procedure.

In the application of ASCE 7-16 Section 13.3.1, seismic forces on components based on the NSP must be based on ASCE 7-16 Equations 13.3-1 through 13.3-3. The quantity S_{MS} must be substituted for the term S_{DS} found in the equations. In the application of ASCE 7-16 Section 13.3.2, the response of the building to the MCE_R ground motion must be used.

C-22.3.3 Nonlinear Dynamic Procedure.

In the application of ASCE 7-16 Section 13.3.1, seismic forces on components based on the NDP must be based on ASCE 7-16 Equation 13.3-4. The term a_{ij} is the maximum acceleration at the level of the component under consideration, as determined from the dynamic analysis. In the application of ASCE 7-16 Section 13.3.2, the response of the building to the MCE_R ground motion must be used.

C-22.3.4 Component Importance Factors.

The component importance factor, I_p , is required for force calculations in ASCE 7-16 Section 13.3.1. I_p must be taken as 1.0, in lieu of the importance factors listed in ASCE 7-16 Section 13.1.3.

C-22.4 Modification of ASCE 7-16 for Immediate Occupancy Design.

C-22.4.1 Ground Motion Parameters for Determination of IO Seismic Forces.

In the application of ASCE 7-16 Section 13.3.1, seismic forces must be determined for the BSE-1N ground motion parameters.

C-22.4.2 Nonlinear Static Procedure.

In the application of ASCE 7-16 Section 13.3.1, seismic forces on components based on the NSP must be based on ASCE 7-10 Equations 13.3-1 through 13.3-3. In the application of ASCE 7-16 Section 13.3.2, the response of the building to the BSE-1N ground motion must be used.

C-22.4.3 Nonlinear Dynamic Procedure.

In the application of ASCE 7-16 Section 13.3.1, seismic forces on components based on the NDP must be based on ASCE 7-16 Equation 13.3-4. The term a_i is the maximum acceleration at the level of the component under consideration, as determined from the dynamic analysis. In the application of ASCE 7-16 Section 13.3.2, the response of the building to the BSE-1N ground motion must be used.

C-22.4.4 Component Importance Factors.

The component importance factor, I_p , is required for force calculations in ASCE 7-16 Section 13.3.1. I_p must be as given in ASCE 7-16 Section 13.1.3.

**Table C-1 System Limitations for Risk Category IV Buildings Designed
Using Alternate Procedure of Chapter 3**

Basic Seismic Force-Resisting System²	System and Building Height (ft) Limita- Seismic Design Cat- egory				
	B	C	D	E	F
	Bearing Wall Systems				
Ordinary steel braced frames in light-frame construction	NL	NL	65	65	65
Special reinforced concrete shear walls	NL	NL	160	160	100
Ordinary reinforced concrete shear walls	NL	NL	NP	NP	NP
Special reinforced masonry shear walls	NL	NL	160	160	100
Light-framed walls with shear panels - wood structural panels/sheet steel panels	NL	NL	65	65	65
Light-framed walls with shear panels - all other materials	NL	NL	35	NP	NP
Light-framed walls with shear panels - using flat strap bracing	NL	NL	65	65	65
Building Frame Systems					
Steel eccentrically braced frames	NL	NL	160	160	100
Special steel concentrically braced frames	NL	NL	160	160	100
Ordinary steel concentrically braced frames	NL	NL	35 ³	35 ³	NP ³
Special reinforced concrete shear walls	NL	NL	160	160	160
Ordinary reinforced concrete shear walls	NL	NL	NP	NP	NP
Composite eccentrically braced frames	NL	NL	160	160	100
Composite special concentrically braced frames	NL	NL	160	160	100
Ordinary composite braced frames	NL	NL	NP	NP	NP
Composite steel plate shear walls	NL	NL	160	160	100
Special composite reinforced concrete shear walls with steel elements	NL	NL	160	160	100
Special reinforced masonry shear walls	NL	NL	160	160	100
Light-framed walls with shear panels - wood structural panels/sheet steel panels	NL	NL	65	65	65
Light-framed walls with shear panels - all other materials	NL	NL	35	NP	NP
Moment-Resisting Frame Systems					
Special steel moment frames	NL	NL	NL	NL	NL
Special steel truss moment frames	NL	NL	160	100	NP
Intermediate steel moment frames	NL	NL	35 ⁵	NP ⁵	NP ⁵
Ordinary steel moment frames	NL	NL	NP ⁶	NP ⁶	NP ⁶
Special reinforced concrete moment frames	NL	NL	NL	NL	NL

Table C-1 (Continued) System Limitations for Risk Category IV Buildings Designed Using Alternate Procedure of Chapter 3

Basic Seismic Force-Resisting System²	System and Building Height (ft) Limitations¹				
	Seismic Design Category				
	B	C	D	E	F
Intermediate reinforced concrete moment frames	NL	NL	NP	NP	NP
Special composite moment frames	NL	NL	NL	NL	NL
Intermediate composite moment frames	NL	NL	NP	NP	NP
Composite partially restrained moment frames	160	160	100	NP	NP
Dual Systems with Special Moment Frames capable of resisting at least 25% of prescribed seismic forces					
Steel eccentrically braced frames	NL	NL	NL	NL	NL
Special steel concentrically braced frames	NL	NL	NL	NL	NL
Special reinforced concrete shear walls	NL	NL	NL	NL	NL
Ordinary reinforced concrete shear walls	NL	NL	NP	NP	NP
Composite eccentrically braced frames	NL	NL	NL	NL	NL
Composite special concentrically braced frames	NL	NL	NL	NL	NL
Composite steel plate shear walls	NL	NL	NL	NL	NL
Special composite reinforced concrete shear walls with steel elements	NL	NL	NL	NL	NL
Ordinary composite reinforced concrete shear walls with steel elements	NL	NL	NP	NP	NP
Special reinforced masonry shear walls	NL	NL	NL	NL	NL
Dual Systems with Intermediate Moment Frames capable of resisting at least 25% of prescribed seismic forces					
Special steel concentrically braced frames ⁴	NL	NL	35	NP	NP
Special reinforced concrete shear walls	NL	NL	160	100	100
Ordinary reinforced concrete shear walls	NL	NL	NP	NP	NP
Composite special concentrically braced frames	NL	NL	160	100	NP
Ordinary composite braced frames	NL	NL	NP	NP	NP
Ordinary composite reinforced concrete shear walls with steel elements	NL	NL	NP	NP	NP
Cantilevered Column Systems detailed to conform to the requirements for:					
Special steel cantilever column systems	35	35	35	35	35
Special reinforced concrete moment frames	35	35	35	35	35

NP - indicates not permitted, NL – indicates not limited.

¹ Any system that is restricted by this table may be permitted if it is approved by the design review panel (see Section C-1.2).

² See Table 3-1 for detailing references for seismic force-resisting systems.

Table C-1 (Continued) System Limitations for Risk Category IV Buildings Designed Using Alternate Procedure of Chapter 3

³ Steel ordinary concentrically braced frames are permitted in single-story buildings, up to a structural height, h_n , of 60 ft, where the dead load of the roof does not exceed 20 psf, and in penthouse structures.

⁴ Ordinary moment frames may be used in lieu of intermediate moment frames for Seismic Design Category B or C.

⁵ See ASCE 7-16 Section 12.2.5.7 for limitations in structures assigned to Seismic Design Category D, E, or F.

⁶ See ASCE 7-16 Section 12.2.5.6 for limitations in structures assigned to Seismic Design Category D, E, or F.

CANCELLED

This Page Intentionally Left Blank

CANCELLED

APPENDIX D GUIDANCE FOR SEISMIC DESIGN OF NONSTRUCTURAL COMPONENTS

D-1 INTRODUCTION.

This Appendix defines architectural, mechanical, and electrical components, discusses their participation and importance in relation to the seismic design of the structural system, and provides guidance for their design to resist damage from earthquake-induced forces and displacements. The fundamental principles and underlying requirements of this Appendix are that the design of these components for buildings in Risk Categories (RCs) I, II, and III should be such that they will not collapse and cause personal injury due to the accelerations and displacements caused by severe earthquakes, and that they should withstand more frequent but less severe earthquakes without excessive damage and economic loss. In contrast, designated components in RC IV buildings, are required to remain operational following a design earthquake.

D-1.1 Design Criteria.

2018 IBC Section 1613, as modified by Chapter 2 of this UFC, governs the seismic design of architectural, mechanical, and electrical components. 2018 IBC Section 1613 references Chapter 13 of ASCE 7-16. Because ASCE 7-16 is the primary source of design requirements for these components, this Appendix cites ASCE 7-16 provisions and amplifies them as appropriate.

D-1.2 Walk-down Inspections and Seismic Mitigation for Buildings in Risk Categories IV.

D-1.2.1 General Guidance.

Section 1705.12.6 of UFC 3-301-01 requires that an initial *walk-down* inspection of new RC IV buildings be performed. A walk-down inspection is a visual inspection of a building to identify possible seismic vulnerabilities of its architectural, mechanical, and electrical components. Inspections should include investigating adequacy of component load paths, anchorage and bracing, and components' abilities to accommodate differential motions with respect to supporting building structure. The walk-down inspector should become familiar with the design earthquake motions for the site, structural configuration of the building, building drawings, and documentation of all previous walk-down inspections. Inspectors should document all observations with photographs, schematic drawings, and narrative discussions of apparent vulnerabilities. Inspection reports normally do not include detailed assessments of component vulnerabilities, but they may recommend further detailed assessments. Inspectors should also define mitigation recommendations in inspection reports. Prior to building commissioning, the Authority Having Jurisdiction (AHJ) should ensure seismic mitigation recommendations are fully implemented. An example of a walk-down inspection of Madigan Army Medical Center at Fort Lewis, WA, may be found in USACERL Technical Report 98/34, *Seismic Mitigation for Equipment at Army Medical Centers*.

D-1.2.2 Periodic Post-commissioning Walk-down Inspections.

In addition to initial walk-down inspections performed at building commissioning, periodic post- construction walk-down inspections should be conducted in RC IV buildings by installation personnel, as part of routine operations and maintenance. For RC IV buildings, such inspections should be conducted at least every second year following building commissioning, or, for affected systems, when any change to architectural, mechanical, or electrical systems occurs.

D-2 ARCHITECTURAL COMPONENTS.

D-2.1 Reference.

ASCE 7-16 Section 13.5, Architectural Components.

D-2.2 General.

Architectural components addressed in ASCE 7-16 Chapter 13 are listed in ASCE 7-16 Table 13.5-1. These components are called “architectural” because they are not part of the vertical or lateral load-resisting systems of a building, or part of the mechanical or electrical systems. Although they are usually shown on architectural drawings, they often have a structural aspect and can affect the response of a building to earthquake ground motions. Architects should consult with structural, mechanical, and electrical engineers, as appropriate, when dealing with these elements. The structural engineer must review architectural (as well as mechanical and electrical) component anchorage details, to ensure compliance with anchorage requirements. During this review, the structural engineer must also identify installed architectural (as well as mechanical and electrical) components that may adversely affect the performance of the structural system.

D-2.3 Typical Architectural Components.

Examples of architectural components that have a structural aspect requiring special attention follow.

D-2.3.1 Nonstructural Walls.

A wall is considered architectural or nonstructural when it is not designed to resist lateral or vertical forces beyond transient interior air pressure of 5psf. To ensure that nonstructural walls do not resist lateral forces, they should either be disconnected from the building structure (i.e., isolated) at the top and the ends of the wall or be very flexible (in-plane) relative to the structural walls and frames resisting lateral forces. An isolated wall must be capable of acting as a cantilever from the floor, or be braced to resist its own out-of-plane motions and loads, without interacting with the lateral force-resisting system. Such interaction may be detrimental to the wall or the lateral force-resisting system or both.

D-2.3.2 Curtain Walls and Filler Walls.

A curtain wall is an exterior wall, often constructed of masonry that lies outside of and usually conceals the structural frame of a building. A filler wall is an infill, usually constructed of masonry, within the structural members of a frame. These walls are often considered architectural in nature if they are designed and detailed by the architect. However, they can act as structural shear walls. If they are connected to the frame, they will be subjected to the deflections of the frame and will participate with the frame in resisting lateral forces. Curtain walls and infill walls in buildings governed by this document should be designed so they do not restrict the deformations of the structural framing under lateral loads (i.e., so they are isolated from building lateral deformations). Lateral supports and bracing for these walls should be provided as prescribed in this Appendix.

D-2.3.3 Partial Infill Walls.

A partial infill wall is one that has a strip of windows between the top of the solid infill and the bottom of the floor above, or has a vertical strip of window between one or both ends of the infill and a column. Such walls require special treatment. If they are not properly isolated from the structural system, they will act as shear walls. The wall with windows along the top is of particular concern because of its potential effect on the adjacent columns. The columns are fully braced where there is an adjacent infill, but are unbraced in the zone between the windows. The upper, unbraced part of the column is a "short column," and its greater rigidity (compared with the other, longer unbraced columns in the system) must be considered in structural design. Short columns are very susceptible to shear failure in earthquakes. Figure D-1 shows a partial infill wall, with short columns on either side of the infill, which should be avoided. All infills in buildings governed by this document should be considered to be nonstructural components, and should be designed so they do not restrict the deformation of the structural framing under lateral loads. In this instance, the partial infill should be sufficiently isolated from the adjacent frame elements to permit those elements to deform in flexure as designed.

D-2.3.4 Precast Panels.

Exterior walls that consist of precast panels attached to the building frame are addressed in a different way. The general layout and wall section for wall panels is usually shown on architectural drawings, while structural details for the support of the panels are usually shown on structural drawings. It is common for the detailed structural design of the precast panels to be delegated to a specialty engineer engaged by the General Contractor or by the precast concrete panel subcontractor. This is done because the details of design may vary depending on the manufacturing methods and facilities of the panel manufacturer. The specialty engineer is engaged to incorporate those considerations as well as means and methods of construction that the project structural engineer excludes from the scope of work. The structural engineer must review this design as

needed to verify that the application of loads and the configuration of the connections details are compatible with the design of the supporting structure. In such cases, structural drawings should include design criteria and representative details in order to show what is expected. The design criteria should include the required design forces and frame deflections that must be accommodated by the panels and their connections. Particular attention should be given to the effects of deflections of the frame members supporting precast panels, to assure that appropriate reaction forces and deflections are considered. Panels with more than two attachment points between their bottom edge and the supporting frame should be avoided. Further guidance can be found in *Architectural Precast Concrete*, 3rd Edition (PCI MNL-122-07), published by the Precast/Pre-stressed Concrete Institute (PCI).

Figure D-1 Partial Infill Masonry Wall between Two Concrete Columns, Causing Adverse “Short Column” Effect

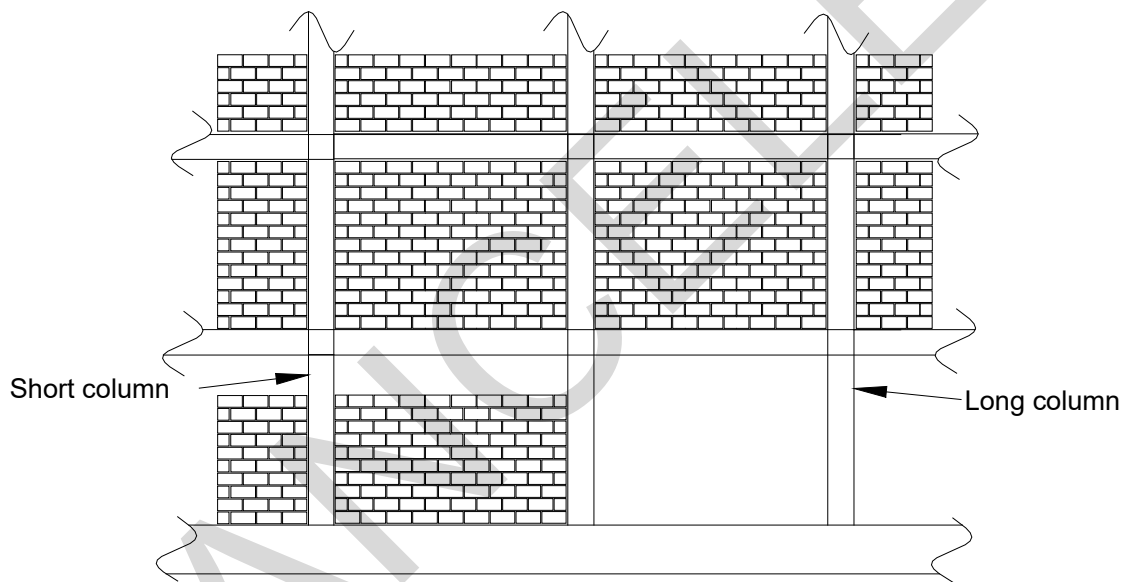

D-2.3.5 Masonry Veneer.

Reference should be made to *Building Code Requirements for Masonry Structures* (TMS 402-16). A masonry veneer is defined as a masonry wythe that provides the exterior finish of a wall system and transfers out-of-plane load directly to a backing, but is not considered to add load-resisting capacity to the wall system. A masonry veneer may be anchored or adhered. An anchored veneer is defined as a masonry veneer secured to and supported laterally by the backing through anchors and supported vertically by the foundation or other structural elements. An adhered veneer is defined as a masonry veneer secured to and supported by the backing through adhesion. Chapter 12 of TMS 402 provides requirements for design and detailing of anchored masonry veneer and adhered masonry veneer. The design of anchored veneer is addressed in Section

12.1.2 of TMS 402, while the design of adhered veneer is addressed in Section 12.1.3 of the same document.

D-2.3.6 Rigid Partition Walls.

Rigid partition walls are generally nonstructural masonry walls. Such walls should be isolated, so they are not called upon to resist in-plane lateral forces to which they are subjected, based on relative rigidities. Typical details for isolating these walls are shown in Figure D-2. These walls should be designed for the prescribed forces normal to their plane.

D-2.3.7 Nonrigid Partition Walls.

Nonrigid partition walls are generally nonstructural partitions, such as stud and drywall, stud and plaster, and movable partitions. When these partitions are constructed according to standard recommended practice, they are assumed to be able to withstand design in-plane drift of only 0.005 times the story height (1/16 in./ft [5 mm/m] of story height) without damage. This is much less than the most restrictive allowable story drift in ASCE 7-16 Table 12.12-1. Therefore, damage to these partitions should be expected in the design earthquake if they are anchored to the structure in the in-plane direction. For RC IV, these partition walls should be isolated from in-plane building motions at the tops and sides of partitions if drifts exceeding 0.005 times the story height are anticipated in the design earthquake. Partition walls should be designed for the prescribed seismic force acting normal to flat surfaces. However, the wind or the usual 5 pounds per square foot partition load (2018 IBC Section 1607.15) will usually govern.

Economic comparison between potential damage and costs of isolation should be considered. For partitions that are not isolated, a decision has to be made for each project as to the contribution, if any, such partitions will make to damping and response of the structure, and the effect of seismic forces parallel to (in-plane with) the partition resulting from the structural system as a whole. Usually, it may be assumed that this type of a partition is subject to future changes in floor layout location. The structural role of partitions may be controlled by limiting the height of partitions and by varying the method of support.

D-2.3.8 Suspended Ceilings.

Requirements for suspended ceilings are provided in ASCE 7-16 Section 13.5.6, as modified by Chapter 3. Useful guidance is available in ICC-ES AC 368 *Acceptance Criteria for Suspended Ceiling Framing Systems*, issued by the International Code Council Evaluation Service (ICC-ES) in July 2015.

D-3 MECHANICAL AND ELECTRICAL COMPONENTS.

D-3.1 Component Support.

D-3.1.1 References.

ASCE 7-16 Section 13.6.4 Component Supports.

Figure D-2 Typical Details for Isolation of Rigid Partition Walls

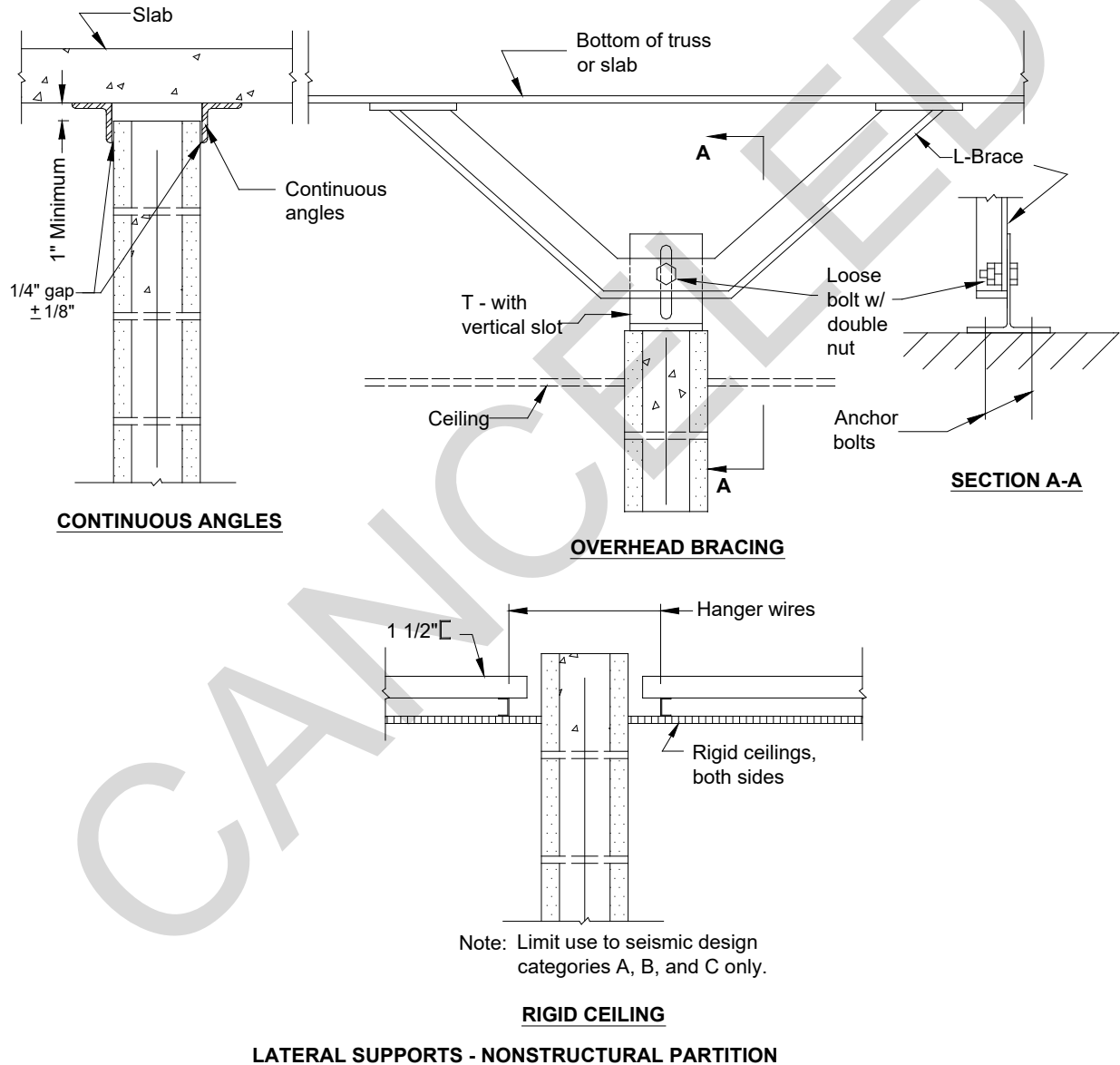

D-3.1.2 Base-mounted Equipment in RC IV.

Floor or pad-mounted mission-critical equipment installed RC IV buildings assigned to SDC D, E, or F should use cast-in-place anchor bolts to anchor them. Alternatively, post-installed anchors are permitted to be used provided they are qualified for earthquake loading in accordance with ACI 355.2, *Qualification of Post-Installed Mechanical Anchors in Concrete*, and ACI 355.4, *Acceptance Criteria for Qualification of Post-Installed Adhesive Anchors in Concrete*, as applicable. For this equipment, two nuts should be provided on each bolt, and anchor bolts should conform to ASTM F1554-07ae1, *Standard Specification for Anchor Bolts, Steel, 36, 55, and 105-ksi Yield Strength*. Cast-in-place anchor bolts should have an embedded straight length equal to at least 12 times the nominal bolt diameter. Anchor bolts that exceed the normal depth of equipment foundation piers or pads should either extend into the concrete floor, or the foundation should be increased in depth to accommodate the bolt lengths. Figure D-3 illustrates typical base anchorage and restraint for equipment.

CANCELLED

Figure D-3 Typical Seismic Restraints for Floor-mounted Equip-

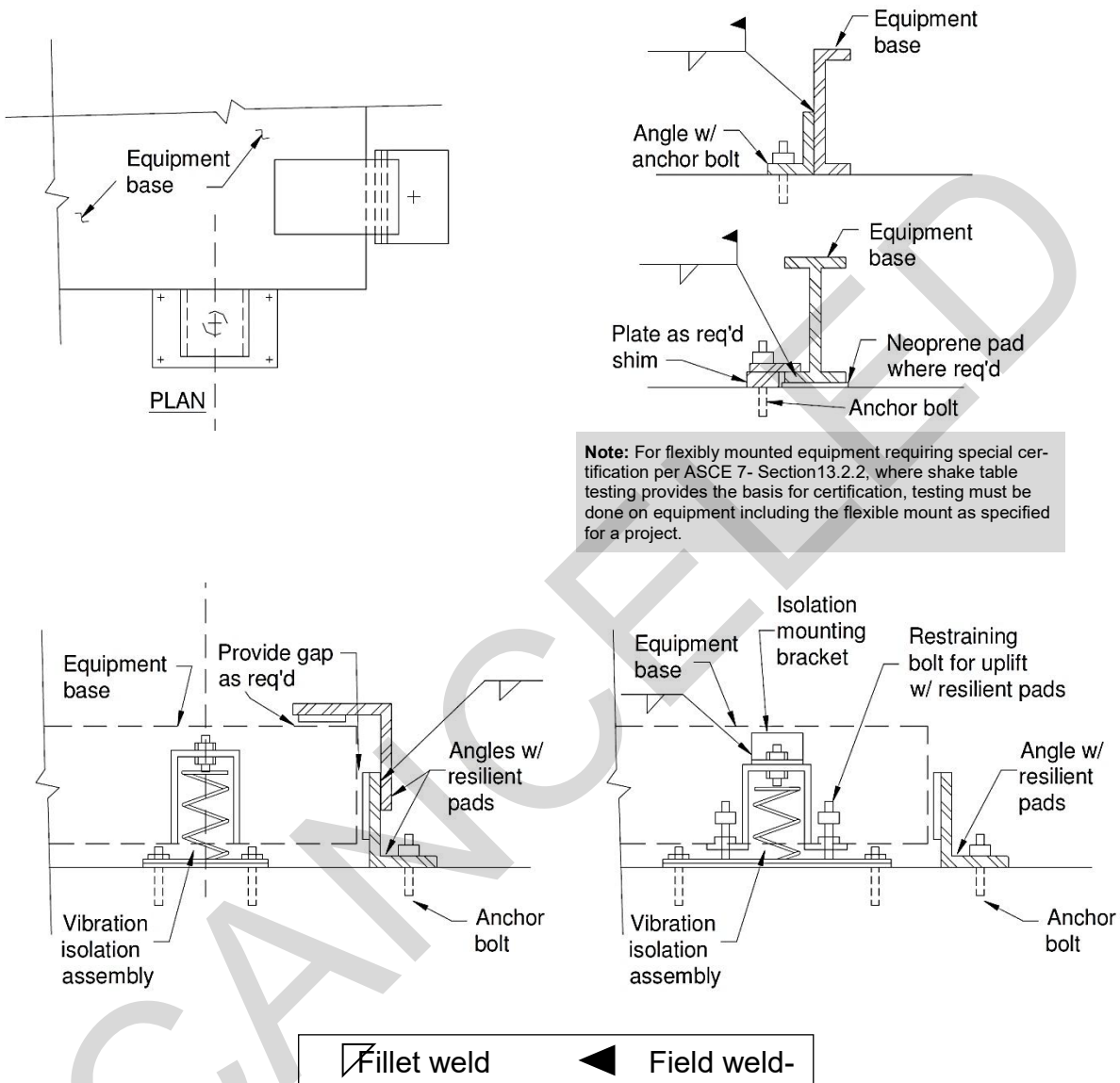

D-3.1.3 Suspended Equipment.

Seismic bracing for suspended equipment may use the bracing recommendations and details in ANSI/SMACNA 001-2008, *Seismic Restraint Manual: Guidelines for Mechanical Systems*, 3rd Edition. Trapeze-type hangers should be secured with not less than two bolts. Figure D-4 shows typical seismic restraints for suspended equipment.

Figure D-4 Typical Seismic Restraints for Suspended Equipment

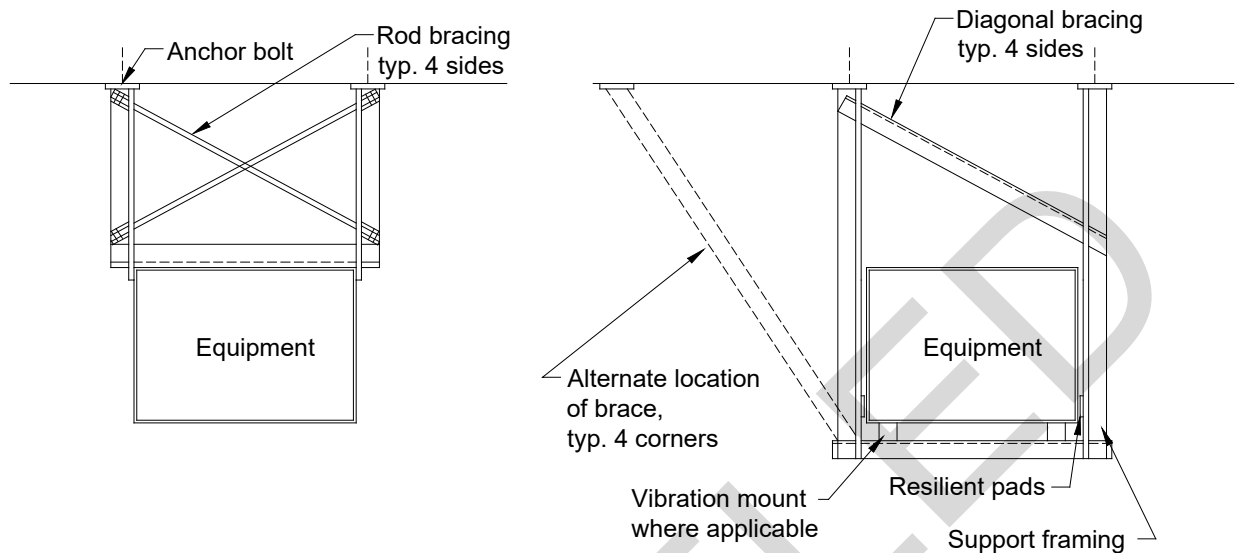

SUSPENDED EQUIPMENT

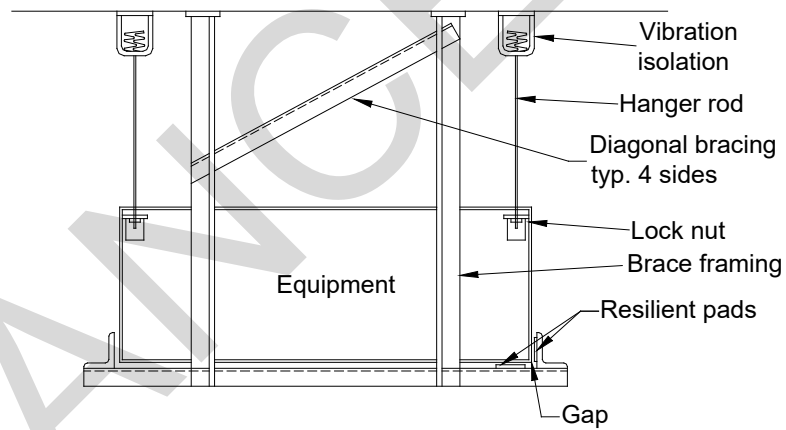

SUSPENDED EQUIPMENT WITH VIBRATION MOUNT

D-3.1.4 Supports and Attachments for Piping.

Seismic supports required in accordance with ASCE 7-16-Section 13.6.7, Distribution Systems: Piping and Tubing Systems, should be designed in accordance with the following guidance. This piping is not constructed in accordance with ASME B31 or NFPA 13.

D-3.1.4.1 General.

The provisions of this section apply to all risers and riser connections; all horizontal pipes and attached valves; all connections and brackets for pipes; flexible couplings and

expansion joints; and spreaders. The following general guidance applies to these elements:

1. For seismic analysis of horizontal pipes, the equivalent static force should be considered to act concurrently with the full dead load of the pipe, including contents.
2. All connections and brackets for pipe should be designed to resist concurrent dead and equivalent static forces. Seismic forces should be determined from ASCE 7-16 Section 13.3.1. Supports should be provided at all pipe joints unless continuity is maintained. Figure D-5 provides acceptable sway bracing details.
3. Flexible couplings should be provided at the bottoms of risers for pipes larger than 3.5 in. (89 mm) in diameter. Flexible couplings and expansion joints should be braced laterally and longitudinally unless such bracing would interfere with the action of the couplings or joints. When pipes enter buildings, flexible couplings should be provided to allow for relative movement between the soil and building.
4. Spreaders should be provided at appropriate intervals to separate adjacent pipelines unless pipe spans and clear distances between pipes are sufficient to prevent contact between the pipes during an earthquake.

D-3.1.4.2 Rigid versus Flexible Piping Systems.

Piping systems should be considered either rigid or flexible. The dynamic response of rigid piping systems is assumed to be decoupled from the building amplified response, so that the component amplification factor, a_p , is set to 1.0 (see ASCE 7-16 Table 13.6-1, note a). It is assumed that flexible pipes may couple with and further amplify building motion, so a_p is set to 2.5. This suggests that pipe system forces, F_p , would be less for rigid pipes; however, that is not necessarily the case because R_p values are larger for flexible pipes than for rigid pipes. Designers are encouraged to use high-deformability pipe systems that may permit longer pipe support spacing in accordance with this guidance. It should be noted that when high deformability pipe systems, which have the larger R_p values, are used (e.g., welded steel pipe systems), F_p may be limited by the minimum value set forth by ASCE 7-16 Equation 13.3-3. Forces based on ASCE 7-16 Equation 13.3-3 may also govern for pipes installed in lower levels of a building.

Figure D-5 Acceptable Seismic Details for Pipe Sway Bracing

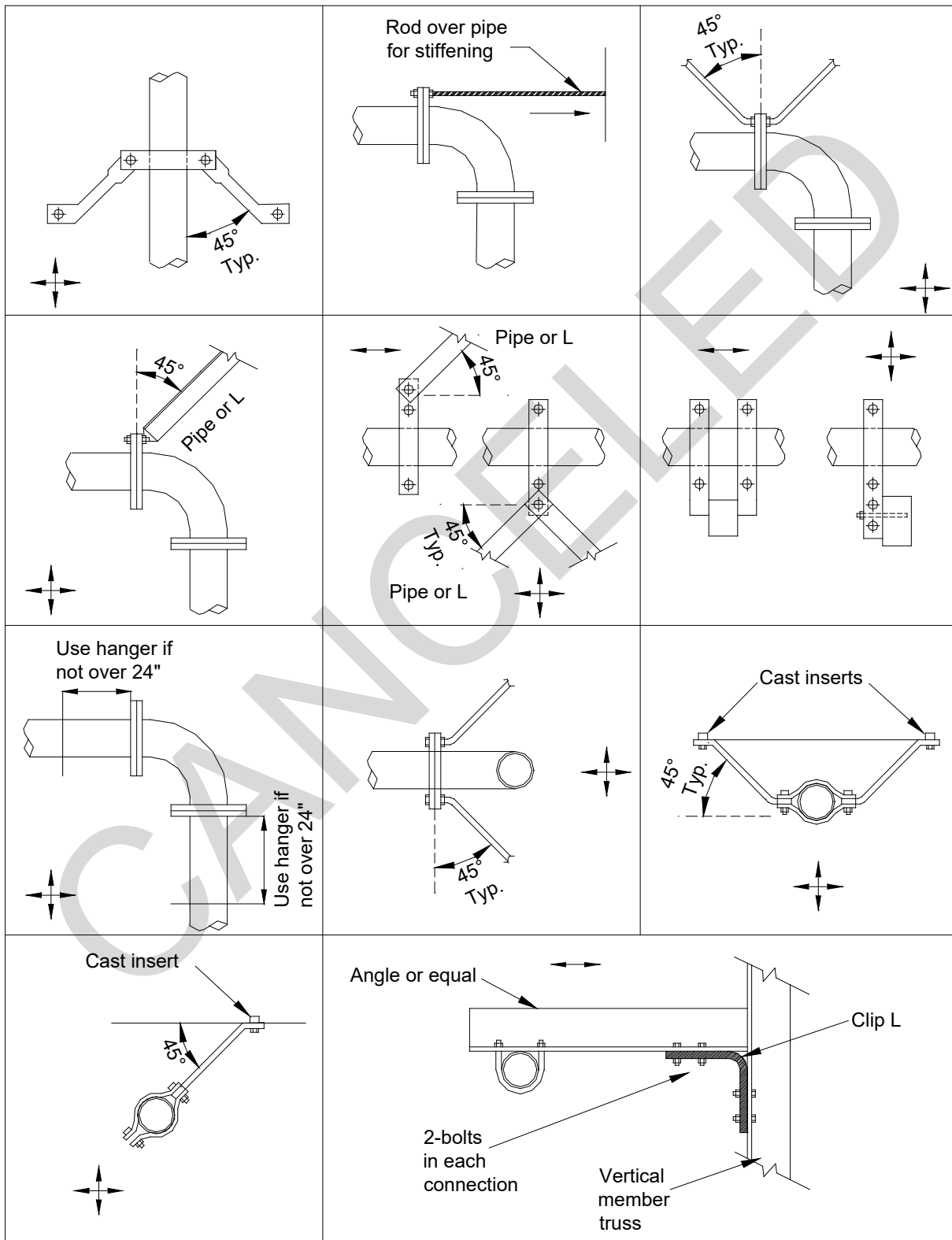

D-3.1.4.2.1 Rigid Piping System.

A piping system is assumed rigid if its maximum period of vibration is no more than 0.06 second (ASCE 7-16-Section 11.2 definition for Component, rigid). ASCE 7-16 Table 13.6-1 Footnote 1 indicates that a_p equals 1.0 for rigid pipes, where the support motions are not amplified. Rigid and rigidly attached pipes should be designed in accordance with ASCE 7 Equation 13.3-1, where W_p is the weight of the pipes, their contents, and attachments. Forces should be distributed in proportion to the total weight of pipes, contents, and attachments.

Tables D-1, D-2, and D-3 may be used to determine allowable span-diameter relationships for rigid pipes; standard (40S) pipe; extra strong (80S) pipe; types K, L, and M copper tubing; and 85 red brass or SPS copper pipe in RC IV buildings. These tables are based on water-filled pipes with periods equal to 0.06 second. Figures D-6, D-7, and D-8 display support conditions for Tables D-1, D-2, and D-3, respectively. The relationship used to determine maximum pipe lengths, L , shown in the tables, that will result in rigid pipes having a maximum period of vibration of 0.06 seconds, is given in Equation D-1 (which is excerpted from the *Shock and Vibration Handbook*, 6th Edition, 2009):

$$L = \sqrt{C \pi T_a \sqrt{\frac{EI_g}{w}}}, \text{ in. or mm} \quad \text{(Equation D-1)}$$

where

C = period constant, equal to 0.50 for pinned-pinned pipes; 0.78 for fixed- pinned pipes; and 1.125 for fixed-fixed pipes

T_a = natural period of pipe in its fundamental mode, set equal to 0.06 second

E = modulus of elasticity of pipe, psi or MPa

I = moment of inertia of pipe, in⁴ or mm⁴

w = weight of pipe and contents per unit length, lb/in. or N/mm

Table D-1
Maximum Span for Rigid Pipe with Pinned-Pinned Conditions, L

Diameter Inches	Std. Wt. Steel Pipe 40S	Ex. Strong Steel Pipe 80S	Copper Tube Type K	Copper Tube Type L	Copper Tube Type M	85 Red Brass & SPS Copper Pipe
1	7'- 0"	7'- 0"	5'- 5"	5'- 4"	4'- 11"	5'- 11"
1 1/2	8'- 5"	8'- 6"	6'- 5"	6'- 3"	5'- 12"	7'- 1"
2	9'- 4"	9'- 5"	7'- 3"	7'- 1"	6'- 10"	7'- 10"
2 1/2	10'- 3"	10'- 5"	7'- 11"	7'- 10"	7'- 5"	8'- 8"
3	11'- 3"	11'- 5"	8'- 8"	8'- 6"	8'- 1"	9'- 6"
3 1/2	11'- 12"	12'- 2"	9'- 3"	9'- 1"	8'- 8"	10'- 2"
4	12'- 8"	12'- 11"	9'- 10"	9'- 9"	9'- 5"	10'- 9"
5	13'- 11"	14'- 3"	10'- 11"	10'- 8"	10'- 4"	11'- 8"
6	15'- 1"	15'- 7"	11'- 12"	11'- 6"	11'- 2"	12'- 7"
8	16'- 12"	17'- 8"				
10	18'- 9"	19'- 4"				
12	20'- 1"	20'- 9"				

Figure D-6 Pinned-pinned Support Condition for Table D-1

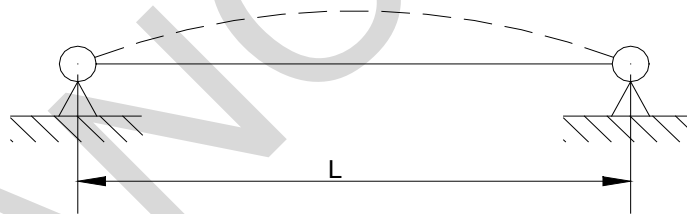

Table D-2
Maximum Span for Rigid Pipe with Fixed-Pinned Condition, L

Diameter Inches	Std. Wt. Steel Pipe 40S	Ex. Strong Steel Pipe 80S	Copper Tube Type K	Copper Tube Type L	Copper Tube Type M	85 Red Brass & SPS Copper Pipe
1	8'- 9"	8'- 10"	6'- 9"	6'- 8"	6'- 1"	7'- 5"
1 1/2	10'- 6"	10'- 7"	7'- 12"	7'- 10"	7'- 6"	8'- 10"
2	11'- 7"	11'- 9"	9'- "	8'- 10"	8'- 6"	9'- 9"
2 1/2	12'- 10"	12'- 12"	9'- 11"	9'- 9"	9'- 4"	10'- 9"
3	14'- 1"	14'- 3"	10'- 10"	10'- 7"	10'- 1"	11'- 10"
3 1/2	14'- 11"	15'- 3"	11'- 7"	11'- 4"	10'- 10"	12'- 8"
4	15'- 9"	16'- 1"	12'- 4"	12'- 2"	11'- 9"	13'- 5"
5	17'- 5"	17'- 10"	13'- 8"	13'- 3"	12'- 10"	14'- 7"
6	18'- 10"	19'- 5"	14'- 11"	14'- 5"	13'- 11"	15'- 8"
8	21'- 2"	22'- 0"				
10	23'- 5"	24'- 2"				
12	25'- 1"	25'- 11"				

Figure D-7 Fixed-pinned Support Condition for Table D-2

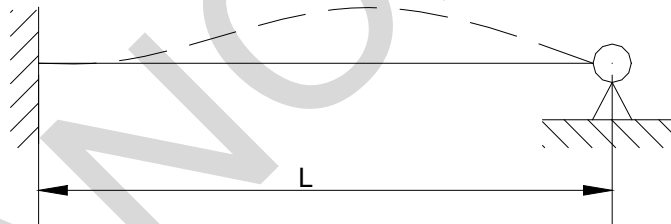
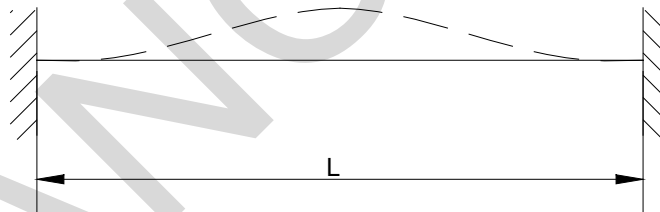

Table D-3
Maximum Span for Rigid Pipe with Fixed-Fixed Condition, *L*

Diameter Inches	Std. Wt. Steel Pipe 40S	Ex. Strong Steel Pipe 80S	Copper Tube Type K	Copper Tube Type L	Copper Tube Type M	85 Red Brass & SPS Copper Pipe
1	10'- 7"	10'- 7"	8'- 1"	7'- 12"	7'- 4"	8'- 11"
1 1/2	12'- 7"	12'- 8"	9'- 7"	9'- 5"	8'- 12"	10'- 8"
2	13'- 11"	14'- 2"	10'- 10"	10'- 8"	10'- 2"	11'- 9"
2 1/2	15'- 5"	15'- 7"	11'- 11"	11'- 9"	11'- 2"	12'- 11"
3	16'- 11"	17'- 2"	12'- 12"	12'- 9"	12'- 1"	14'- 3"
3 1/2	17'- 12"	18'- 4"	13'- 11"	13'- 8"	13'- 1"	15'- 3"
4	18'- 11"	19'- 4"	14'- 9"	14'- 8"	14'- 2"	16'- 1"
5	20'- 11"	21'- 5"	16'- 5"	15'- 11"	15'- 5"	17'- 7"
6	22'- 7"	23'- 4"	17'- 12"	17'- 4"	16'- 9"	18'- 10"
8	25'- 6"	26'- 5"				
10	28'- 2"	29'- 0"				
12	30'- 2"	31'- 1"				

Figure D-8 Fixed-fixed Support Condition for Table D-3



D-3.1.4.2.2 Flexible Piping Systems.

Piping systems that do not comply with the rigidity requirements of Section D-3.1.4.2.1 (i.e., period less than or equal to 0.06 second) should be considered flexible (i.e., period greater than 0.06 second). Flexible piping systems should be designed for seismic forces with consideration given to both the dynamic properties of the piping system and the building or structure in which it is placed. In lieu of a more detailed analysis, equivalent static lateral force may be computed using ASCE 7 Equation 13.3-1, with $a_p = 2.5$. The forces should be distributed in proportion to the total weight of pipes, contents, and attachments. If the weight of attachments is greater than 10% of pipe weight, attachments should be separately braced, or substantiating calculations should be required. If temperature stresses are appreciable, substantiating calculations should be required. The following guidance should also be followed for flexible pipe systems:

1. Separation between pipes should be a minimum of four times the calculated maximum displacement due to F_p , but not less than 4 in. (102 mm) clearance between parallel pipes, unless spreaders are provided.
2. Clearance from walls or rigid elements should be a minimum of three times the calculated displacement due to F_p , but not less than 3 in. (76 mm) clearance from rigid elements.
3. If the provisions of the above paragraphs appear to be too severe for an economical design, alternative methods based on rational and substantial analysis may be applied to flexible piping systems.
4. Acceptable seismic details for sway bracing are shown in Figure D-5.

D-3.2 Stacks (Exhaust) Associated with Buildings.

D-3.2.1 References.

ASCE 7 Section 13.6, as modified by Section 13.6.1 of Chapter 3 of this UFC, and Chapter 15 .

D-3.2.2 General.

Stacks are actually vertical beams with distributed mass and, as such, cannot be modeled accurately by single-mass systems. This design guidance applies to either cantilever or singly-guyed stacks attached to buildings. When a stack foundation is in contact with the ground and the adjacent building does not support the stack, it should be considered to be a nonbuilding structure (see ASCE 7 Chapter 15). This guidance is intended for stacks with a constant moment of inertia. Stacks having a slightly varying moment of inertia should be treated as having a uniform moment of inertia with a value equal to the average moment of inertia.

Stacks that extend more than 15 ft (4.6 m) above a rigid attachment to the supporting building should be designed according to the guidance for cantilever stacks presented in Section D-3.2.3. Stacks that extend less than 15 ft (4.6 m) should be designed for the equivalent static lateral force defined in ASCE 7 Section 13.3.1 using the a_p and R_p values in ASCE 7 Table 13.6-1.

Stacks should be anchored to supporting buildings using long anchor bolts (where bolt length is at least 12 bolt diameters). Much more strain energy can be absorbed with long anchor bolts than with short ones. The use of long anchor bolts has been demonstrated to give stacks better seismic performance. A bond-breaker material should be used on the upper portion of the anchor bolt to ensure a length of unbonded bolt for strain energy absorption. Two nuts should be used on anchor bolts to provide an additional factor of safety.

D-3.2.3 Cantilever Stacks.

The fundamental period of a cantilever stack should be determined from the period coefficient (e.g., $C = 0.0909$) provided in Figure D-9, unless actually computed. The equation and the period coefficients, C , shown in Figure D-9 were derived from the *Shock and Vibration Handbook* (6th Edition, 2009). Dynamic response of ground-supported stacks may be calculated from the appropriate base shear equations for the Equivalent Lateral Force Procedure defined in ASCE 7 Section 12.8.

D-3.2.4 Guyed Stacks.

Analysis of guyed stacks depends on the relative rigidities of cantilever component and guy cable support systems. If a cable is relatively rigid compared to the cantilever component, the stack should respond in a manner similar to the higher modes of vibration of a cantilever, with periods and mode shapes similar to those shown in Figure D-9. The fundamental period of vibration of the guyed system should be somewhere between the values for the fundamental and the appropriate higher mode of a similar cantilever stack. An illustration for a single guyed stack is shown in Figure D-10. Guyed stacks should be designed with rigid cables so that the true deflected shape is closer to that shown on the right side of Figure D-10. This requires pretensioning of guy cables to a minimum of 10 percent of stack seismic forces, F_p . Design for guyed stacks is beyond the scope of this document. However, some guidance may be found in TIA-222-G, *Structural Standards for Antenna Supporting Structures and Antennas*, 2005, including Addendum 2, 2009.

D-3.3 Elevators.

D-3.3.1 References.

ASCE 7 Section 13.6.11, "Elevator and Escalator Design Requirements," as modified by Section 13.6.11.3 of Chapter 3 of this UFC.

D-3.3.2 General.

Elevator car and counterweight frames, roller guide assemblies, retainer plates, guide rails, and supporting brackets and framing (Figure D-11) should be designed in accordance with ASCE 7 Section 13.6.11. Lateral forces acting on guide rails should be assumed to be distributed one-third to top guide rollers and two-thirds to bottom guide rollers of elevator cars and counterweights. An elevator car and/or counterweight should be assumed to be located at its most adverse position in relation to its guide rails and support brackets. Horizontal deflections of guide rails should not exceed 1/2 in. (12.7 mm) between supports, and horizontal deflections of the brackets should not exceed 1/4 in. (6.4 mm).

Figure D-9 Period Coefficients for Uniform Beams

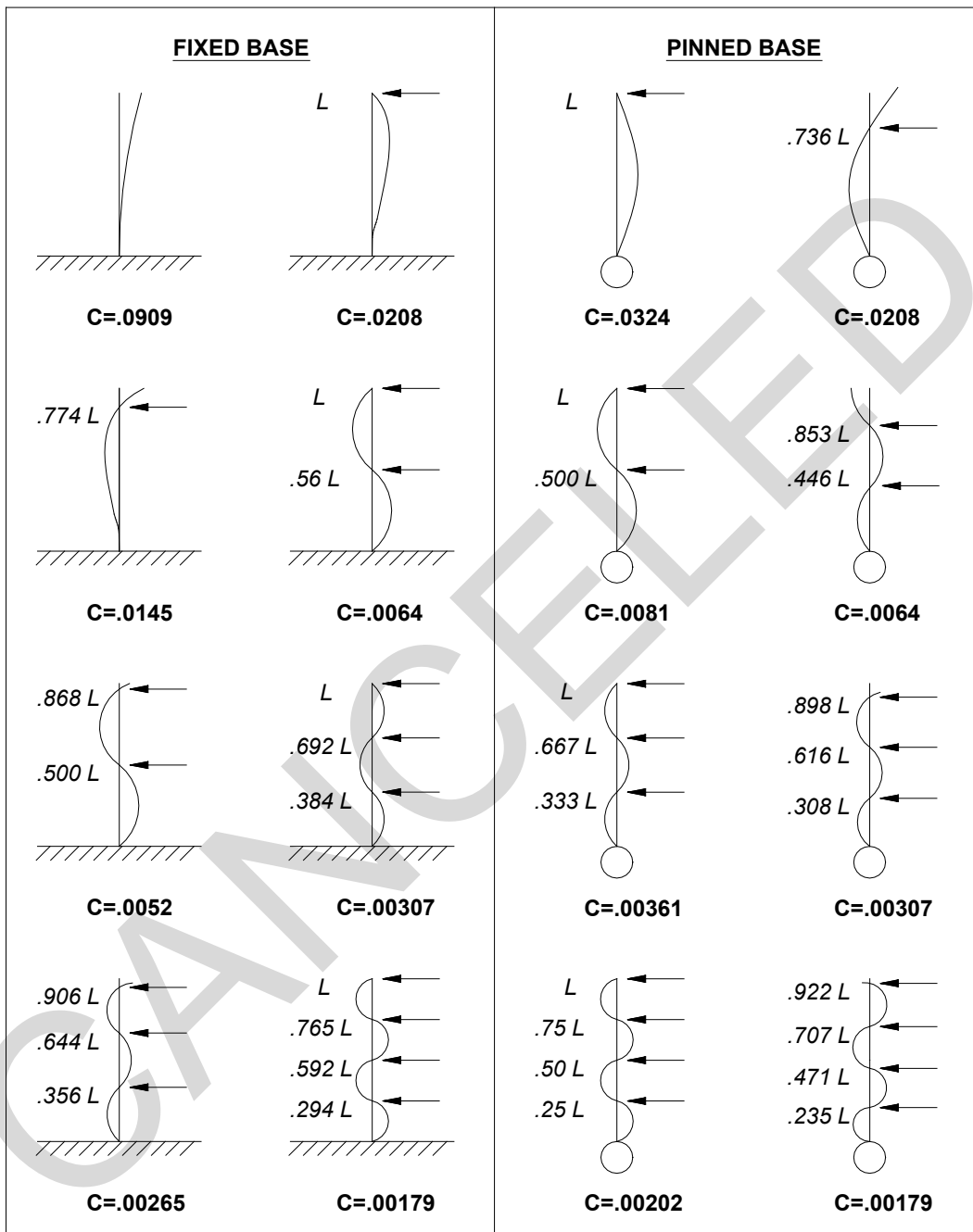

$$T_a = C \sqrt{\frac{wL^4}{EI}}$$

T_a = Fundamental period (sec)
 w = Weight per unit length of beam (lb/in) (N/mm)
 L = Total beam length (in) (mm)
 I = Moment of inertia (in⁴) (mm⁴)
 E = Modulus of elasticity (psi) (MPa)
 C = Period constant

Figure D-10 Single Guyed Stacks.

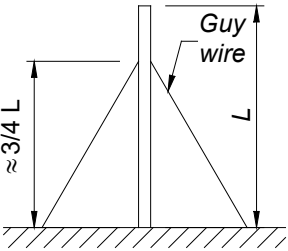
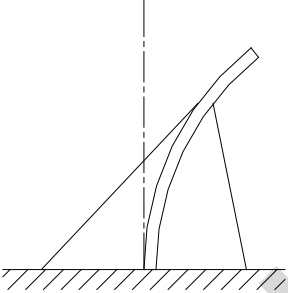
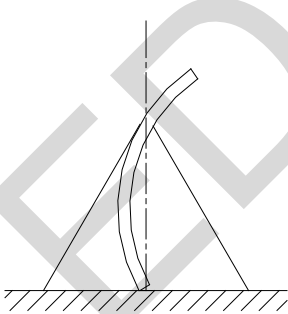
DESCRIPTION	DEFLECTED SHAPE	
	FLEXIBLE WIRE	RIGID WIRE
		

D-3.3.3 Retainer Plates.

In structures assigned to SDC D, E, and F, clearances between the machined faces of rail and retainer plates should not be more than 3/16 in. (4.8 mm), and the engagement of a rail should not be less than the dimension of its machined side face. When a car safety device attached to lower members of a car frame complies with lateral restraint requirements, a retainer plate is not required for the bottom of the car.

D-3.3.4 Counterweight Tie Brackets.

In structures assigned to SDC D, E, and F, the maximum spacing of counterweight rail tie brackets tied to a building structure should not exceed 16 ft (4.9 m). An intermediate spreader bracket, which is not required to be tied to a building structure, should be provided for tie brackets spaced greater than 10 ft (3.0 m), and two intermediate spreader brackets are required for tie brackets spaced greater than 14 ft (4.3 m).

D-3.3.5 Force Calculation.

Elevator machinery and equipment should be designed for $a_p = 1.0$ in ASCE 7 Equation 13.3-1, when rigid and rigidly attached. Non-rigid or flexibly mounted equipment (which has a period greater than 0.06 second) should be designed with $a_p = 2.5$.

Figure D-11 Elevator Details

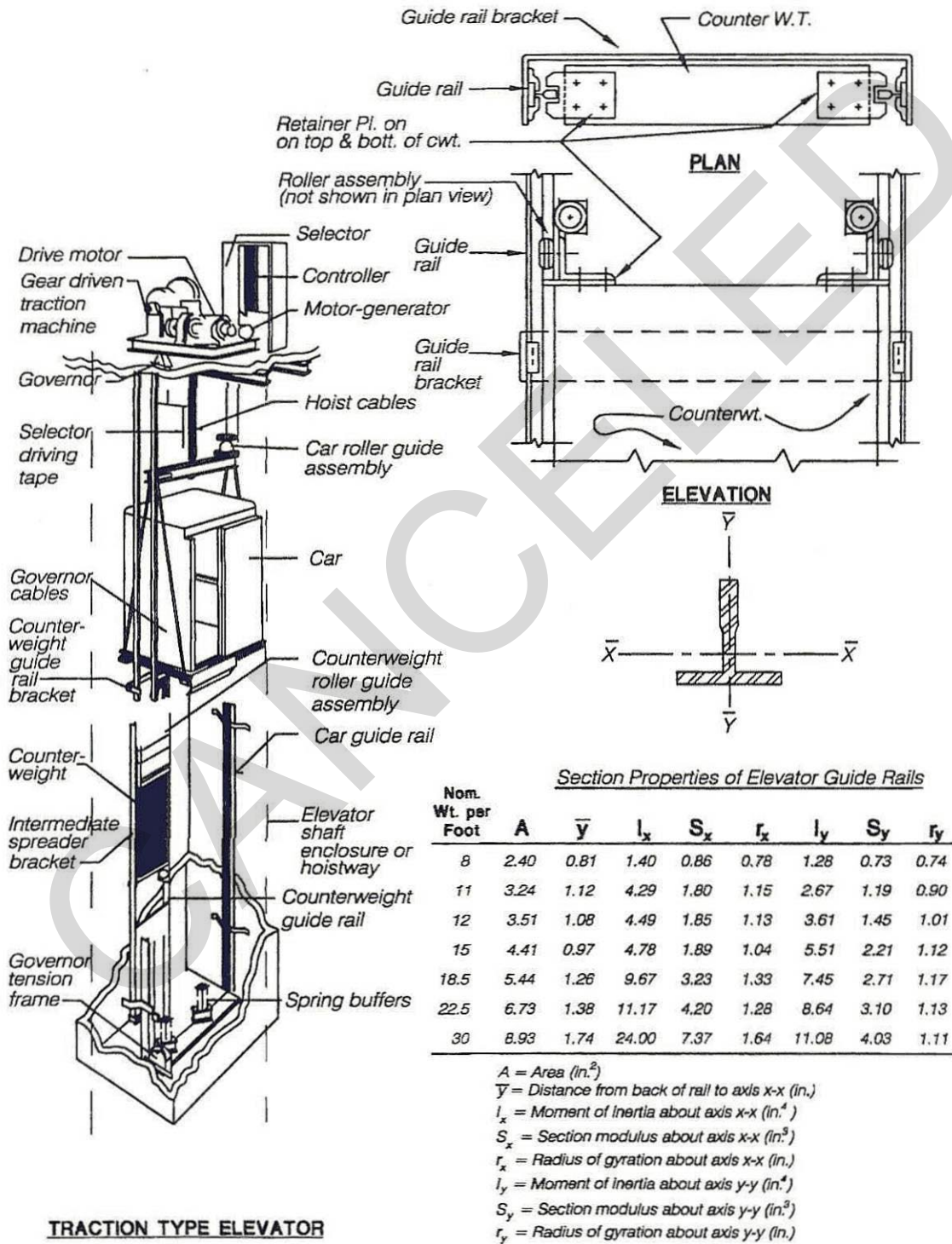

D-3.4 Lighting Fixtures in Buildings

D-3.4.1 Reference.

ASCE 7 Sections 13.2.5 Testing Alternative for Seismic Capacity Determination, 13.5.6 Suspended Ceilings, 13.6.1 General, 13.6.2 Mechanical Components, 13.6.3 Electrical Components, and 13.6.4 Component Supports as modified by Chapter 3 of this UFC in the Sections 13.5.6, 13.6.1, 13.6.2, 13.6.3, and 13.6.4. .

D-3.4.2 General.

Lighting fixtures, including their attachments and supports, in SDC C, D, E, and F buildings should conform to the following materials and construction requirements:

1. Fixture supports should use materials that are suitable for that purpose. Cast metal parts, other than those of malleable iron, and cast or rolled threads, should be subject to special investigation to ensure structural adequacy.
2. Loop and hook or swivel hanger assemblies for pendant fixtures should be fitted with restraining devices to hold their stems in the support position during earthquake motions. Pendant-supported fluorescent fixtures should also be provided with flexible hanger devices at their attachments to the fixture channel to preclude breaking of the support. Motions of swivels or hinged joints should not cause sharp bends in conductors or damage to insulation.
3. A supporting assembly that is intended to be mounted on an outlet box should be designed to accommodate mounting features on 4 in. (102 mm) boxes, 3 in. (76 mm) plaster rings, and fixture studs.
4. Each surface-mounted individual or continuous row of fluorescent fixtures should be attached to an earthquake-resisting ceiling support system. Support devices for attaching fixtures to suspended ceilings should be locking-type scissor clamps or full loop bands that will securely attach to the ceiling support. Fixtures attached to the underside of a structural slab should be properly anchored to the slab at each of their corners.
5. Each wall-mounted emergency light unit should be secured in a manner that will hold the unit in place during a seismic disturbance.

D-3.5 Bridges, Cranes, and Monorails.

D-3.5.1 References.

ASCE 7 Section 13.6 Mechanical and Electrical Component, as modified by Chapter 3 of this UFC in the Sections 13.6.14 Bridges, Cranes, and Monorails and 13.6.14.1 Bridges, Cranes, and Monorails for RC IV Buildings and 2018 IBC Section 1607.14.

D-3.5.2 General.

2018 IBC Section 1607.14 provides live load design guidance for cranes. Vertical restraints should be provided to resist crane uplift. Experience has shown that vertical ground motions can be amplified significantly in either crane bridges or crane rail support brackets that are cantilevered from columns. Analysis of cranes should consider their amplified response in the vertical direction, in addition to horizontal response. The criteria in Section 13.6.14 in Chapter 3 of this UFC specify a component amplification factor, a_p , of 2.5 in the direction parallel to crane rails, because a crane bridge would almost certainly be flexible enough in its weak axis to have a natural period greater than 0.06 seconds. This factor is greater than 1.0 because, at large natural periods, a crane bridge can be expected to amplify ground and building motions. This factor has a value of 1.0 perpendicular to crane rails because the bridge would be loaded axially in this direction, resulting in a natural period that is less than 0.06 second. The crane bridge is considered to be rigid when loaded axially, so that it will not amplify ground or building motions. When a crane is not in the locked position, it is reasonable to assume that upper bound forces in the direction parallel to crane rails, between the wheels and the rails, cannot exceed a conservative estimate of the force that could be transmitted by friction between the brake wheels and rails.

APPENDIX E MECHANICAL AND ELECTRICAL COMPONENT CERTIFICATION

E-1 COMPONENT CERTIFICATION.

E-1.1 General.

The background to mechanical and electrical component certification is explained in *Special Seismic Certification of Nonstructural Components* (Tobolski, M. Structural Engineering and Design, 2011).

ASCE 7 Section 13.2 states that certification shall be by analysis, testing or experience data. Mechanical and electrical equipment that must remain operable following the design earthquake must be certified based on shake table testing or experience data unless it can be shown that the component is inherently rugged by comparison with similar seismically qualified components (Section 13.2.2). ASCE 7 Section 13.2.2 Item 2 states that “Components with hazardous substances and assigned a component Importance Factor, I_p , of 1.5 in accordance with Section 13.1.3 shall be certified by the manufacturer as maintaining containment following the design earthquake by (1) analysis, (2) approved shake table testing in accordance with Section 13.2.5, or (3) experience data in accordance with Section 13.2.6.”

The California Office of Statewide Health Planning and Development (OSHPD) has published Code Application Notice (CAN) 2-1708A.5, which explicitly explains OSHPD’s expectations as they relate to special seismic certification. The main focus of the CAN must emphasize items requiring physical shake table testing. OSHPD has also created a Special Seismic Certification Preapproval (OSP) program. This program offers a means to obtain prequalification of product lines for special seismic certification. Lists of equipment that is pre-approved by OSHPD can be found at <http://www.oshpd.ca.gov/FDD/Pre-Approval/SpecSeisCert-IrgeScrn-wModelCol.html> and <http://www.oshpd.ca.gov/FDD/Pre-Approval/OSP-List-by-Category.pdf>. The basis of OSHPD preapproval always is shake table testing in compliance with ICC-ES AC156 and satisfaction of ICC-ES AC156 post-test acceptance criteria.

E-1.1.1 References.

ASCE 7 Section 13.2, General Design Requirements, and Chapter 3 Section 13.2.2.

E-1.1.2 Analytical Certification.

Certification based on analysis, as noted in ASCE 7 Section 13.2.2 Item 3, requires a reliable and conservative understanding of the equipment configuration, including the mass distribution, strength, and stiffness of the various subcomponents. From this information, an analytical model may be developed that reliably and conservatively predicts the equipment dynamic response and potential controlling modes of failure. If such detailed information on the equipment or a basis for conservative estimates of these properties is not available, then methods other than analysis must be used. The

use of analysis for active or energized components is not permitted (see ASCE 7 Section 13.2.2). Any analytical qualification of equipment should be peer-reviewed independently by qualified, Registered Design Professionals.

E-1.1.3 Certification Based on Testing.

Shake table tests conducted in accordance with either ICC-ES AC156, *Acceptance Criteria for Seismic Qualification by Shake-Table Testing of Nonstructural Components*, or a site-specific study, should first use uniaxial motions along each of the three principal axes of the equipment that is being tested. The measured response recorded with vibration response monitoring instrumentation should be reviewed to determine if out-of-plane response (in terms of peak amplitude) at a given location of instrumentation exceeds 20% of the in-plane response. The in-plane direction is the direction of horizontal test motions, while the out-of-plane direction is at a horizontal angle of 90 degrees with respect to the in-plane axis. An out-of-plane response (equipment relative acceleration or equipment deformation) that exceeds 20% of the in-plane response, for either horizontal test, indicates that significant cross-coupling is occurring. In that case, the final qualification test should be triaxial, with simultaneous phase-incoherent motions along all three principal axes. If out-of-plane response is less than 20% of the in-plane response for both horizontal tests, at each critical location instrumented, then the final qualification tests can be biaxial with motions in one horizontal and the vertical directions. After post-test inspection and functional compliance verification, the Unit Under Test (UUT) may be rotated 90 degrees about the vertical axis and biaxial testing for the other horizontal direction and vertical direction can be conducted. Normally, two biaxial tests, rather than a single triaxial test, would be conducted when a triaxial shake table is not available or the displacement capacity of a triaxial shake table in one direction must be so small.

The development of ICC-ES AC156 is documented in *ASCE Structures Congress Proceedings: Background on the Development of the NEHRP Seismic Provisions for Non-Structural Components and their Application to Performance Based Seismic Engineering* (Gillengerten, J.D., and Bachman, R.E., ASCE Structures Congress, 2003). For RC V facilities the site-specific seismic site response analysis will result in a set of site-specific ground motions that define the seismic hazard. The building model could be analyzed with these motions to define predicted time-history motions at each location where critical equipment must be installed. From these building response motions, response spectra could be developed, using 5% of critical damping. If the equipment will be placed at several locations in the same building or in multiple buildings, a required response spectrum (RRS) could be developed that envelopes all the spectra generated from each building response record. As an alternative to the ICC-ES AC156 procedure, the equipment could be qualified with triaxial motions fit to the RRS, but generated according to ICC-ES AC156. A second alternative approach would be to test with the predicted time history motions that have the greatest response spectra amplitude at the measured natural frequency of the equipment in each of the principal directions. Using worst-case records would require that resonance search shake table tests be conducted in each of the three principal directions as defined in ICC-ES AC156. All alternatives to

ICC-ES AC156 equipment qualification testing require peer review of the development of test records and test plans by qualified, Registered Design Professionals. Post-test inspection and functional compliance verification would still be required in accordance with ICC-ES AC156.

E-1.1.4 Additional Certification Methods.

Three additional methods are permitted for defining equipment capacity: earthquake experience data, seismic qualification testing data, and the CERL Equipment Fragility and Protection Procedure. The use of these methods requires a peer review by a qualified, Registered Design Professional.

E-1.1.4.1 Earthquake Experience Data.

Earthquake experience data that were obtained by surveying and cataloging the effects of strong ground motion earthquakes on various classes of equipment mounted in conventional power plants and other industrial facilities may be used. Section 4.2.1 of the publication *Generic Implementation Procedure (GIP) for Seismic Verification of Nuclear Plant Equipment* (DOE 1992) provides these data. Based on this work, a Reference Spectrum would be developed to represent the seismic capacity of equipment in the earthquake experience equipment class. DOE/EH-0545, *Seismic Evaluation Procedure for Equipment in U.S. Department of Energy Facilities*, provides guidance on this procedure. A detailed description of the derivation and use of this Reference Spectrum is contained in DoE publication SAND92-0140, *Use of Seismic Experience Data to Show Ruggedness of Equipment in Nuclear Power Plants*. This document should be reviewed before using the Reference Spectrum. The Reference Spectrum and four spectra from which it is derived are shown in Figure 5.3-1 of DOE/EH-0545. The Reference Spectrum and its defining response levels and frequencies are shown in Figure 5.3-2 of the same document. When this approach is used, the Reference Spectrum is used to represent the seismic capacity of equipment, when the equipment is determined to have characteristics similar to the earthquake experience equipment class and meets the intent of the caveats for that class of equipment as defined in Chapter 8 of DOE/EH-0545.

E-1.1.4.2 Qualification Testing Database.

Data collected from seismic qualification testing of nuclear power plant equipment may be used in the certification of equipment. These data were used to develop generic ruggedness levels for various equipment classes in the form of Generic Equipment Ruggedness Spectra (GERS). The development of the GERS and the limitations on their use are documented in Electric Power Research Institute (EPRI) report NP-5223, *Generic Seismic Ruggedness of Power Plant Equipment in Nuclear Power Plants*. The nonrelay GERS and limitations on their use are discussed in Chapter 8 of DOE/EH-0545, while the relay GERS are in Chapter 11 of the same document. The EPRI report should be reviewed by users of the GERS to understand the basis for them. The use of either the Reference Spectrum or the GERS for defining equipment capacity requires

careful review of the basis for them to ensure applicability to the equipment being evaluated.

E-1.1.4.3 CERL Equipment Fragility and Protection Procedure.

The CERL Equipment Fragility and Protection Procedure (CEFAPP), defined in USACERL Technical Report 97/58, may be used for defining equipment capacity. Similar to the other methods, CEFAPP defines a response spectrum envelope of the equipment capacity. This method requires a series of shake table tests to develop an actual failure envelope across a frequency range. This experimental approach requires greater effort than the ICC-ES AC156 qualification testing. However, the resulting failure envelope provides a more accurate and complete definition of capacity, rather than simply determining that the equipment survived a defined demand environment. Unlike the AC156 procedure, site-specific testing, or the other two additional methods, CEFAPP defines actual equipment capacity and provides information on modes of failure with respect to response spectra amplitudes and frequency of motion. Definitions of equipment capacity are more accurate with respect to frequency and mode of failure than can be established using the alternative methods. When equipment capacity is compared with the seismic demands at the various locations in which the equipment must be installed, the equipment vulnerability, if any, can be clearly defined in terms of predicted mode of failure and frequency. The procedure provides information on how to protect the equipment, using isolation, strengthening, or stiffening. The use of CEFAPP requires peer review of proposed test motions, the test plan, and use of the data, by qualified Registered Design Professionals.

E-1.1.4.4 Qualification of Power Substation Equipment.

IEEE Recommended Practices for Seismic Design of Substations (IEEE 693-2005) provides detailed guidance for the qualification of equipment used in power substations. This guidance should be used for the qualification of this equipment even if installed at facilities other than substations (e.g., power plants).

APPENDIX F ABBREVIATIONS

g	Gravitational Acceleration
µm	Micrometer (micron)
3-D	Three Dimensional
AASHTO	American Association of State Highway and Transportation Officials
ACI	American Concrete Institute
AEC	Architect/Engineer/Construction
AFCEC	Air Force Civil Engineer Center
AHJ	Authority Having Jurisdiction (See MIL-STD 3007, Change 2, Nov 2018)
AISC	American Institute of Steel Construction
ANSI	American National Standards Institute
AREMA	American Railway Engineering and Maintenance-of-Way Association
ASCE	American Society of Civil Engineers
ASM	American Society for Metals
ASME	American Society of Mechanical Engineers
ASSE	American Society of Safety Engineers
ASTM	American Society for Testing and Materials, now ASTM International
ATFP	Anti-Terrorism Force Protection
ATCT	Air Traffic Control Tower
AWWA	American Water Works Association
BIA	Brick Industry Association (formerly Brick Institute of America)
BPON	Basic Performance Objective Equivalent to New Building Standards
BSE	Basic Safety Earthquake

CEFAPP CERL Equipment Fragility and Protection Procedure

CERL Construction Engineering Research Laboratory (formerly USACERL)

CP Collapse Prevention

CRREL Cold Regions Research and Engineering Laboratory

DC Damage Control

DoD Department of Defense

DoE Department of Energy

ELF Equivalent Lateral Force

EPRI Electric Power Research Institute

ERDC U.S. Army Engineer Research and Development Center

FEMA Federal Emergency Management Agency

GERS Generic Equipment Ruggedness Spectra

GIP Generic Implementation Procedure

GSREB Guidelines for Seismic Retrofit of Existing Buildings

HVAC Heating, Ventilating, and Air Conditioning

IBC International Building Code

ICC-ES International Code Council – Evaluation Service

ICSSC Interagency Committee on Seismic Safety in Construction

IEBC International Existing Building Code

IEEE Institute of Electrical and Electronics Engineers

IMF Intermediate Moment Frame

In...... Inches
In./ft...... Inch per Foot
ICBO International Conference of Building Officials
IO Immediate Occupancy (Performance Objective/Level)
ISAT International Seismic Application Technologies
kg Kilogram
kg/m³ Kilograms per Cubic Meter
km/h..... Kilometers per Hour
kN..... Kilonewton
kN/m Kilonewton per Meter
kN/m² Kilonewton per Square Meter
kPa..... Kilopascal
lb/ft..... Pounds per Foot
lb..... Pounds
LmS Limited Safety
LRFD..... Load and Resistance Factor Design
LS..... Life Safety (Performance Objective/Level)
m..... Meter
m/s Meters per Second
m²..... Square Meter
MC-1 Mission-Critical Level 1
MC-2 Mission-Critical Level 2
MCE_R Risk-Targeted Maximum Considered Earthquake

mil	0.001 Inch
mm	Millimeter
mm²	Square Millimeter
MPa	Megapascal
MPa/m	Megapascal per Meter
mph	Miles per Hour
MRI	Mean Recurrence Interval
NACE	National Association of Corrosion Engineers
NAS	National Academy of Science
NAVFAC	Naval Facilities Engineering Command
NCMA	National Concrete Masonry Association
NDP	Nonlinear Dynamic Procedure
NEHRP	National Earthquake Hazards Reduction Program
NFPA	National Fire Protection Association
NFS	Non-Frost Susceptible
NIST	National Institute of Standards and Technology
NL	Not Limited
NMC	Non-Mission-Critical
NSP	Nonlinear Static Procedure
O&M	Operation and Maintenance
OCBF	Ordinary Concentrically Braced Frame
OMF	Ordinary Moment Frame

OP Operational (Performance Objective/Level)

OSHPD The California Office of Statewide Health Planning and Development

OSP OSHPD Special Seismic Certification Preapproval Program

pci Pounds per Cubic Inch

psf Pounds per Square Foot

psi Pounds per Square Inch

PSSQ Project Specific Seismic Qualification

PTI Post-Tensioning Institute

RACF Radar Approach Control Facility

RC Risk Category

RCSC Research Council on Structural Connections

RFP Request for Proposal

RP Recommended Practice (also Resource Paper)

RRS Required Response Spectrum

SBC Standard Building Code

SDC Seismic Design Category

SDI Steel Deck Institute

SEAOC Structural Engineers Association of California

SEI Structural Engineering Institute

SER Structural Engineer of Record

SIOR Special Inspector of Record

SMF Special Moment Frame

TDLF Total Design Lateral Force

TI..... Technical Instruction

TIA Tentative Interim Agreement; Telecommunications Industry Association

TMS..... The Masonry Society

TRS Test Response Spectrum

UBC Uniform Building Code

UFC..... Unified Facilities Criteria

UFGS Unified Facilities Guide Specifications

URM Unreinforced Masonry

USACE..... U.S. Army Corps of Engineers

USACERL... United States Army Construction Engineering Research Laboratory (now ERDC-CERL)

UUT..... Unit Under Test

V_{asd}..... Allowable Stress Design Wind Speed

V_{fm}..... Fastest Mile Wind Speed

V..... Basic Design Wind Speed

WEF Water Environment Federation

APPENDIX G MINIMUM UNIFORMLY DISTRIBUTED LIVE LOADS, L_o , AND MINIMUM CONCENTRATED LIVE LOADS

G-1 REFERENCES.

All section references are to the 2018 International Building Code (2018 IBC). Table G-1 includes 2018 IBC Table 1607.1 with additional Occupancy or Use classification for military facilities that are shown in bold italics.

Table G-1 Minimum Uniformly Distributed Live Loads and Minimum Concentrated Live Loads⁹

OCCUPANCY OR USE	UNIFORM		CONCENTRATED	
	(kPa)	(psf)	(kN)	(lbs.)
1. Apartments (see residential)	---	---	---	---
2. Access floor systems				
Office use	2.4	50	8.9	2,000
Computer use	4.8	100	8.9	2,000
3. Ammunition Storage				
<i>High explosives (one story)</i>	23.9	500	---	---
<i>Inert explosives (one story)</i>	23.9	500	---	---
<i>Pyrotechnics (one story)</i>	23.9	500	---	---
<i>Small arms (one story)</i>	23.9	500	---	---
<i>Torpedo (one story)</i>	16.8	350	---	---
4. Armories and drill rooms	7.2 ⁿ	150 ⁿ	---	---
5. Assembly areas				
Fixed seats (fastened to floor)	2.9 ^m	60 ^m	---	---
Follow spot, projection and control rooms	2.4	50	---	---
Lobbies	4.8 ^m	100 ^m	---	---
Movable seats	4.8 ^m	100 ^m	---	---
Stage floors	7.2 ^m	150 ^m	---	---
Platforms (assembly)	4.8 ^m	100 ^m	---	---
Other assembly areas	4.8 ^m	100 ^m	---	---
6. Balconies and decks ^h	4.8	1.5 times the live load for the area served, not required to exceed 100	---	---
<i>(Balconies serving as primary means of egress for multiple rooms must be considered as corridors.)</i>				
7. Battery charging room	9.6	200	---	---
8. Boiler houses	9.6	200	---	---
9. Catwalks	1.9	40	1.33	300
10. Cleaning gear / trash room compactor	3.6	75	---	---

OCCUPANCY OR USE	UNIFORM		CONCENTRATED	
	(kPa)	(psf)	(kN)	(lbs.)
11. Cold Storage (Food or provision freezer) <i>First floor</i> <i>Upper floors</i>	19.2 14.4	400 300	---	---
12. Command Duty Officer Day room	2.9	60	---	---
13. Cornices	2.9	60	---	---
14. Corridors First floor Other floors	4.8 Same as occupancy served except as indicated	100 Same as occupancy served except as indicated	---	---
15. Court rooms	3.8	80	---	---
16. Dining rooms and restaurants	4.8 ^m	100 ^m	---	---
18. Dwellings (see residential)	---	---	---	---
19. Elevator machine room and control room grating (on area of 50.8 mm x 50.8 mm (2 in. x 2 in.))	---	---	1.33	300
20. Finish light floor plate construction (on area of 25.4 mm x 25.4 mm (1 in. x 1 in.))	---	---	0.89	200
21. Fire escapes On single-family dwellings only	4.8 1.9	100 40	---	---
22. Galleys <i>Dishwashing rooms</i> <i>General kitchen area</i> <i>Provision storage (not refrigerated)</i> <i>Preparation room</i> <i>Meat</i> <i>Vegetable</i>	14.4 12.0 9.6 12.0 4.8	300 250 200 250 100	---	---
23. Garages (passenger vehicles only) Trucks & buses	1.9° See IBC Section 1607.7	40° See IBC Section 1607.7	Note a See IBC Section 1607.7	Note a See IBC Section 1607.7
24. Generator rooms	9.6	200	---	---
25. Guard House	3.6	75	---	---
26. Handrails, guards and grab bars	See IBC Section 1607.8	See IBC Section 1607.8	See IBC Section 1607.8	See IBC Section 1607.8

UFC 3-301-01
1 October 2019
Change 1, 4 February 2022

OCCUPANCY OR USE	UNIFORM		CONCENTRATED	
	(kPa)	(psf)	(kN)	(lbs.)
27. Helipads ^P	See IBC Section 1607.6	See IBC Section 1607.6	See IBC Section 1607.6	See IBC Section 1607.6
28. Hospitals				
Corridors above first floor	3.8	80	4.45	1,000
Operating rooms, laboratories	2.9	60	4.45	1,000
Patient rooms	1.9	40	4.45	1,000
29. Hotels (see residential)	---	---	---	---
30. Incinerators; charging room	7.2	150	---	---
31. Laboratories, normal scientific equipment	6.0	125	---	---
32. Latrines / Heads / Toilets / Washroom	3.6	75	---	---
33. Libraries				
Reading rooms	2.9	60	4.45	1,000
Stack rooms	7.2 ^{b,n}	150 ^{b,n}	4.45	1,000
Corridors above first floor	3.8	80	4.45	1,000
34. Manufacturing				
Light	6.0 ^m	125 ⁿ	8.9	2,000
Heavy	12.0 ^m	250 ⁿ	13.34	3,000
35. Marquees, except one- and two-family dwellings	3.6	75	---	---
36. Mechanical equipment room (general) ^q	4.8	100	---	---
37. Mechanical room (HVAC, elevator machine rooms and floors over elevator hoistways)	6.0	125	---	---
38. Mechanical telephone and radio equipment room	7.2	150	---	---
39. Morgue	4.8	100	---	---
40. Office buildings				
File and computer rooms shall be designed for heavier loads based on anticipated occupancy	---	---	---	---
Lobbies and first floor corridors	4.8	100	8.9	2,000
Offices	2.4	50	8.9	2,000
Corridors above first floor	3.8	80	8.9	2,000
41. Penal Institutions				
Cell blocks	1.9	40	---	---
Corridors	4.8	100	---	---

OCCUPANCY OR USE	UNIFORM		CONCENTRATED	
	(kPa)	(psf)	(kN)	(lbs.)
42. Post offices				
<i>General area</i>	4.8	100	---	---
<i>Work rooms</i>	6.0	125	---	---
43. Power plants	9.6	200	---	---
44. Projection booths	4.8	100	---	---
45. Pump houses	4.8	100	---	---
46. Recreation room	4.8	100	---	---
47. Recreational uses:				
Bowling alleys, poolrooms and similar uses	3.6 ^m	75 ^m		
Dance halls and ballrooms	4.8 ^m	100 ^m		
Gymnasiums	4.8 ^m	100 ^m		
Ice skating rink	12 ⁿ	250 ⁿ	---	---
Reviewing stands, grandstands and bleachers	4.8 ^{c,m}	100 ^{c,m}		
Roller skating rink	4.8 ^m	100 ^m		
Stadiums and arenas with fixed seats (fastened to floor)	2.9 ^{c,m}	60 ^{c,m}		
48. Receiving rooms (radio) including roof areas supporting antennas and electronic equipment	7.2	150	---	---
49. Refrigeration storage rooms				
<i>Dairy</i>	9.6	200	---	---
<i>Meat</i>	12.0	250	---	---
<i>Vegetable</i>	13.2	275	---	---
50. Residential				
One & two family dwellings				
Uninhabitable attics without storage ⁱ	0.5	10	---	---
Uninhabitable attics with storage ^{i,j,k}	1.0	20	---	---
Habitable attics and sleeping areas ^k	1.4	30	---	---
Canopies, including marquees	1.0	20	---	---
All other areas	1.9	40		
Hotels and multifamily dwellings				
Private rooms & corridors serving them	1.9	40	---	---
Corridors serving as primary means of egress to multiple private rooms	3.8	80	---	---
Public rooms ^m and corridors serving them	4.8	100		

OCCUPANCY OR USE	UNIFORM		CONCENTRATED	
	(kPa)	(psf)	(kN)	(lbs.)
51. Roofs				
All roof surfaces subject to maintenance workers	---	---	1.33	300
Awnings and canopies:				
Fabric construction supported by a skeleton structure	0.23 ^m	5 ^m	---	---
All other construction, except one and two-family dwellings	1.0	20		
Ordinary flat, pitched, and curved roofs (that are not occupiable)	1.0	20	---	---
Primary roof members exposed to a work floor				
Single panel point of lower chord of roof trusses or any point along primary structural members supporting roofs over manufacturing, storage warehouses, and repair garages				
All other primary roof members	---	---	8.9	2000
Occupiable roofs:				
Roof gardens	---	---	1.33	300
Assembly areas	4.8	100	---	---
All other similar areas	4.8 ^m	100 ^m	---	---
Roof of PV shade structures	Note I 1.0	Note I 20	Note I	Note I
52. Schools				
Classrooms	1.9	40	4.45	1,000
Corridors above first floor	3.8	80	4.45	1,000
First floor corridors	4.8	100	4.45	1,000
53. Scuttles, skylight ribs, and accessible ceilings	---	---	0.89	200
54. Shops: Manufacturing and Industrial				
Aircraft utility	9.6	200	---	---
Assembly and repair	12.0	250	---	---
Bombsight (w/o shielding)	6.0	125	---	---
Carpenter	6.0	125	---	---
Electrical	14.4	300	---	---
Engine overhaul	14.4	300	---	---
55. Sidewalks, vehicular driveways and yards, subject to trucking	12.0 ^{d,n}	250 ^{d,n}	35.6 ^e	8,000 ^e
56. Stairs and exits				
One- and two-family dwellings	1.9	40	1.3 ^f	300 ^f
All other	4.8	100	1.3 ^f	300 ^f

OCCUPANCY OR USE	UNIFORM		CONCENTRATED	
	(kPa)	(psf)	(kN)	(lbs.)
57. Storage warehouses (shall be designed for heavier loads if required for anticipated storage)				
General				
Light	6.0 ⁿ	125 ⁿ		
Heavy	12 ⁿ	250 ⁿ		
Aircraft	9.6	200		
Building Materials	12	250	---	---
Drugs, paint, oil	9.6	200		
Dry Provisions	14.4	300		
Groceries, wine, Liquor	14.4	300		
Light Tools	7.2	150		
Pipe & metal	48	1000		
Paint and oil (one story)	24	500		
Hardware	14.4	300		
58. Stores				
Retail				
First floor	4.8	100	4.45	1,000
Upper floors	3.6	75	4.45	1,000
Wholesale, all floors	6.0 ⁿ	125 ⁿ	4.45	1,000
59. Tailor shop	3.6	75	---	---
60. Telephone exchange rooms and central computer IT server spaces	7.2	150	8.9	2000
61. Vehicle barriers	See IBC Section 1607.9	See IBC Section 1607.9	See IBC Section 1607.9	See IBC Section 1607.9
62. Walkways and elevated platforms (other than exitways)	2.9	60	---	---
Range Towers, Climbing Towers and other Multi-story Training Towers	4.8	100		
Pedestrian Bridges	AASHTO^r	AASHTO^r		
63. Yards and terraces, pedestrian	4.8 ^m	100 ^m	---	---

Notes to Table G-1, “Minimum Uniformly Distributed Live Loads, L_o , and Minimum Concentrated Live Loads”

For SI: 1 inch = 25.4 mm, 1 square inch = 645.16 mm², 1 square foot = 0.0929 m², 1 pound per square foot = 0.0479 kN/m² = 0.0479 kPa, 1 pound = 0.004448 kN, 1 pound per cubic foot = 16 kg/m³.

- a. Floors in garages or portions of building used for the storage of motor vehicles shall be designed for the uniformly distributed live loads of this table or the following concentrated loads: (1) for garages restricted to passenger vehicles accommodating not more than nine passengers, 3,000 pounds (13.34 kN) acting on an area of 4.5 inches x 4.5 inches (114 mm x 114 mm); (2) for mechanical parking structures without slab or deck which are used for storing passenger vehicles only, 2,250 pounds (10.0 kN) per wheel.
- b. The loading applies to stack room floors that support nonmobile, double-faced library book stacks, subject to the following limitations:
 - 1) The nominal book stack unit height shall not exceed 90 inches (2,290mm).
 - 2) The nominal shelf depth shall not exceed 12 inches (305mm) for each face;
 - 3) Parallel rows of double-faced book stacks shall be separated by aisles not less than 36 inches (915 mm) wide.
- c. Design in accordance with the ICC 300.
- d. Other uniform loads in accordance with an approved method containing provisions for truck loadings shall also be considered where appropriate.
- e. The concentrated wheel load shall be applied on an area of 4.5 inches by 4.5 inches (114mm x 114mm).
- f. The minimum concentrated load on stair treads shall be applied on an area of 2 inches by 2 inches (51mm x 51mm). This load need not be assumed to act concurrently with the uniform load.
- g. Where snow loads occur that are in excess of the design conditions, the structure shall be designed to support the loads due to the increased loads caused by drift buildup or a greater snow design determined by the **AHJ**. (See IBC Section 1608).
- h. See IBC Section 1604.8.3 for decks attached to exterior walls.
- i. Uninhabitable attics without storage are those where the maximum clear height between the joist and rafter is less than 42 inches (1067 mm), or where there are not two or more adjacent trusses with web configuration capable of accommodating an assumed rectangle 42 inches (1067 mm) in height by 24 inches (610 mm) in width, or greater, within the plane of the truss. This live load need not be assumed to act concurrently with any other live load requirements.
- j. Uninhabitable attics with storage are those where the maximum clear height between the joist and rafter is 42 inches (1067 mm) or greater, or where there are two

or more adjacent trusses with web configuration capable of accommodating an assumed rectangle 42 inches (1067 mm) in height by 24 inches (610 mm) in width, or greater, within the plane of the trusses.

The live load need only be applied to those portions of the joists or truss bottom chords where both of the following conditions are met:

- 1) The attic area is accessible from an opening not less than 20 inches (508 mm) in width by 30 inches (762 mm) in length that is located where the clear height in the attic is a minimum of 30 inches (762 mm); and
- 2) The slopes of the joists or truss bottom chords are no greater than two units vertical in 12 units horizontal.

The remaining portions of the joist or truss bottom chords shall be designed for a uniformly distributed concurrent live load of not less than 10 psf (0.5 kPa).

- k. Attic spaces served by stairways other than the pull-down type shall be designed to support the minimum live load specified for habitable attics and sleeping rooms.
- l. Areas of occupiable roofs, other than roof gardens and assembly areas, shall be designed for appropriate loads as approved by the **AHJ**. Unoccupied landscaped areas of roof shall be designed in accordance with IBC Section 1607.13.3.
- m. Live load reduction is not permitted.
- n. Live load reduction is only permitted in accordance with Section 1607.11.1.2 or Item 1 of Section 1607.11.2.
- o. Live load reduction is only permitted in accordance with Section 1607.11.1.3 or Item 2 of Section 1607.11.2.
- p. Helipads supporting military aircraft shall be designed to support the actual aircraft weight and impact loading due to landing.
- q. All attics with mechanical units shall be designed for a mechanical equipment room loading.
- r. For live loads on pedestrian bridges see AASHTO LRFD *Guide Specifications for the Design of Pedestrian Bridges*.