

UNIFIED FACILITIES CRITERIA (UFC)

ROOFING



UNIFIED FACILITIES CRITERIA (UFC)

ROOFING

Any copyrighted material included in this UFC is identified at its point of use. Use of the copyrighted material apart from this UFC must have the permission of the copyright holder.

U.S. ARMY CORPS OF ENGINEERS

NAVAL FACILITIES ENGINEERING COMMAND (Preparing Activity)

AIR FORCE CIVIL ENGINEER SUPPORT AGENCY

Record of Changes (changes are indicated by \1\ ... /1/)

Change No.	Date	Location
1	22 May 2014	1-8.4, 2.2, 2-3.5, 2-3.6, 2-5.1, 2-8.1.3, 6-9.2: Miscellaneous editorial changes 2-8.3: Thickness of weldable thermoplastic membranes changed to 60 mil (1.52 mm) 5-2.4: Insulated metal roof panels allowed in limited circumstances. 6-3.1, 6-3.2, 6.4: MREC rewritten
2	01 Jan 2017	1-8.5 ccr #5041 revisions. 1-8.8 ccr #4878 clarification on cool roofing; removed date from ASHRAE 90.1 reference. 1-8.9 ccr #5222 rewrote to clarify application to new and existing roof. 2-3.1 ccr #4153 added ref to IPC. Ccr #4476, #5098 and #4668 TPO changes: Paragraphs 2-7 and 2-8 rewritten to include TPO membranes as suitable roofing type. Table 2-1 updated. B-8 revised. B-14 added. These are USACE TPO Roofing lessons learned.

FOREWORD

The Unified Facilities Criteria (UFC) system is prescribed by MIL-STD 3007 and provides planning, design, construction, sustainment, restoration, and modernization criteria, and applies to the Military Departments, the Defense Agencies, and the DoD Field Activities in accordance with [USD \(AT&L\) Memorandum](#) dated 29 May 2002. UFC will be used for all DoD projects and work for other customers where appropriate. All construction outside of the United States is also governed by Status of Forces Agreements (SOFA), Host Nation Funded Construction Agreements (HNFA), and in some instances, Bilateral Infrastructure Agreements (BIA.) Therefore, the acquisition team must ensure compliance with the most stringent of the UFC, the SOFA, the HNFA, and the BIA, as applicable.

UFC are living documents and will be periodically reviewed, updated, and made available to users as part of the Services' responsibility for providing technical criteria for military construction. Headquarters, U.S. Army Corps of Engineers (HQUSACE), Naval Facilities Engineering Command (NAVFAC), and Air Force Civil Engineer Center (AFCEC) are responsible for administration of the UFC system. Defense agencies should contact the preparing service for document interpretation and improvements. Technical content of UFC is the responsibility of the cognizant DoD working group. Recommended changes with supporting rationale should be sent to the respective service proponent office by the following electronic form: [Criteria Change Request](#). The form is also accessible from the Internet sites listed below.

UFC are effective upon issuance and are distributed only in electronic media from the following source:

- Whole Building Design Guide web site <http://dod.wbdg.org/>.

Refer to UFC 1-200-01, *General Building Requirements*, for implementation of new issuances on projects.

AUTHORIZED BY:



JAMES C. DALTON, P.E.
Chief, Engineering and Construction
U.S. Army Corps of Engineers



JOSEPH E. GOTT, P.E.
Chief Engineer
Naval Facilities Engineering Command



TERRY G. EDWARDS, P.E.
Director, Air Force Center for
Engineering and the Environment
Department of the Air Force



MICHAEL McANDREW
Director, Facility Investment and
Management
Office of the Deputy Under Secretary of
Defense (Installations and Environment)

**UNIFIED FACILITIES CRITERIA (UFC)
NEW DOCUMENT SUMMARY SHEET**

Subject: UFC 3-110-03, *Roofing*, dated 1 May 2012.

Cancel: UFC 3-110-03, *Roofing*, dated 26 September 2006, UFC 3-320-03A, *Structural Considerations for Metal Roofing*, dated 1 March 2005 with Change 2 dated October 2010, UFC 3-330-02A, *Commentary On Roofing Systems*, dated 1 March 2005 and MIL-HDBK-1001/5, *Roofing and Waterproofing*, dated 28 February 1990 .

Description of Changes: UFC 3-110-03 updates the roofing design criteria for DOD.

Reasons for Changes:

- Updated to coordinate with the latest editions of the National Roofing Contractor Association's Roofing Manual and Metal Building Manufacturer's Association Roofing Manual and to meet the latest DOD requirements.

Impact: There are negligible cost impacts. However, the following benefits should be realized.

- By using the current industry standards, designers and contractors will be more familiar with the criteria.
- Continuing to rely on commercial standards minimizes the need for future revisions.

TABLE OF CONTENTS

CHAPTER 1 INTRODUCTION	1
1-1 PURPOSE AND SCOPE.....	1
1-2 APPLICABILITY.....	1
1-3 GENERAL BUILDING REQUIREMENTS.....	1
1-4 CONTENTS.....	1
1-4.1 System Design.....	1
1-4.2 Appendices.....	2
1-5 BACKGROUND.....	2
1-6 SYSTEM SELECTION.....	3
1-6.1 New Construction.....	3
1-6.2 Existing Structures.....	3
1-7 SYSTEM TYPES.....	3
1-8 GENERAL DESIGN REQUIREMENTS.....	3
1-8.1 Unified Facilities Guide Specifications (UFGS).....	3
1-8.2 Wind Resistance Rating.....	4
1-8.3 Thermal Expansion.....	4
1-8.4 Air and Vapor Barriers.....	4
1-8.5 Elimination, Prevention and Control of Fall Hazards.....	4
1-8.6 Roof Hatches.....	5
1-8.7 Skylights.....	5
1-8.8 Cool Roofs.....	5
1-8.9 Photovoltaic Systems – Rack Mounted Systems.....	5
1-8.10 Design Professional Qualifications.....	6
1-8.11 Warranty Requirements.....	6
1-8.12 Roof Information Card.....	7
CHAPTER 2 LOW-SLOPE ROOFING DESIGN REQUIREMENTS	9
2-1 GENERAL.....	9
2-2 DESIGN-BUILD.....	9
2-3 GENERAL LOW-SLOPE ROOFING REQUIREMENTS.....	9
2-3.1 Positive Drainage.....	9
2-3.2 Roof Curb Heights.....	9

2-3.3	Horizontal Roof Top Duct Work.	9
2-3.4	Snow and Ice.	9
2-3.5	Hail.	10
2-3.6	Vegetative Roofing Systems.....	10
2-4	ROOF DECKS.....	11
2-4.1	Deck Slope.	11
2-4.2	Types of Roof Decks.	11
2-5	RIGID BOARD ROOF INSULATION.....	12
2-5.1	General.....	12
2-5.2	Types of Roof Insulation.	12
2-6	COVER BOARDS.	14
2-6.1	General.....	14
2-6.2	Types of Cover Boards.	14
2-7	SUITABLE ROOF MEMBRANES.....	14
2-8	GUIDANCE FOR ROOF MEMBRANES.....	15
2-8.1	Asphalt BUR Membranes.	15
2-8.2	MB Membranes.	16
2-8.3	Thermoset EPDM Membranes.	17
2-8.4	Weldable Thermoplastic Membranes.	18
	Fully adhered weldable thermoplastic systems do not allow billowing of the roof membrane and are the preferred method of installation.	18
2-8.5	Thermoplastic Polyolefin (TPO).	18
2-8.6	Hot Rubberized Reinforced Fluid-applied Membranes.	18
2-9	LOW-SLOPE CONSTRUCTION DETAILS.....	18
CHAPTER 3	STEEP-SLOPE ROOFING DESIGN REQUIREMENTS.....	21
3-1	GENERAL.....	21
3-2	DESIGN-BUILD.....	21
3-3	GENERAL STEEP-SLOPE ROOFING REQUIREMENTS.....	21
3-3.1	Self-Adhering Underlayment.....	21
3-3.2	Overhangs.	22
3-3.3	Curb Heights.....	22
3-3.4	Metal Flashing.	22
3-3.5	Gutters and Downspouts.	22

3-3.6	Snow and Ice Considerations.....	23
3-3.7	Hail Resistance.....	23
3-3.8	Fall Protection.....	23
3-4	ASPHALT SHINGLES.....	23
3-4.1	Wind Pressure.....	23
3-4.2	Perimeter Drip Edge.....	23
3-4.3	Valley Flashing.....	23
3-4.4	Underlayments.....	24
3-5	TILE ROOFING.....	24
3-5.1	Slope.....	24
3-5.2	Fasteners.....	24
3-5.3	Flashing.....	25
3-5.4	Perimeter Drip Edge.....	25
3-5.5	Batten Boards.....	25
3-5.6	Snow Guards.....	25
3-5.7	Roof Cement.....	25
3-5.8	Self-Adhering Underlayment.....	25
3-5.9	Felt Underlayment.....	25
3-6	SLATE ROOFING.....	25
3-6.1	Roof Cement.....	26
3-6.2	Self-Adhering Underlayment.....	26
3-6.3	Felt Underlayment.....	26
3-6.4	Snow Guards and Fences.....	26
3-7	OTHER STEEP-SLOPE ROOFING.....	26
3-8	STEEP-SLOPE CONSTRUCTION DETAILS.....	26
CHAPTER 4	ROOF SYSTEM RELATED SHEET METAL FLASHINGS.....	28
4-1	GENERAL.....	28
4-2	REFERENCE STANDARDS.....	28
4-3	SHEET METAL.....	28
4-3.1	Sheet Metal Type.....	28
4-3.2	Sheet Metal Gauge and Thickness.....	28
4-3.3	Organic Coatings.....	28

4-4	MATERIAL COMPATIBILITY.	29
4-5	EXPANSION AND CONTRACTION	29
CHAPTER 5 STANDING SEAM METAL ROOFING SYSTEM DESIGN REQUIREMENTS		31
5-1	INTRODUCTION.	31
5-2	GENERAL REQUIREMENTS.	31
5-2.1	Design-Build.	31
5-2.2	Panels Type.....	31
5-2.3	Overhangs.	32
5-2.4	Insulated Metal Panels.	32
5-2.5	Corrosion Treatment.....	32
5-2.6	Organic Coatings.	32
5-2.7	Metal Thickness.....	33
5-2.8	Panel Attachment.	33
5-2.9	Flashings and Penetrations.	34
5-2.10	Other Rooftop Appurtenances.....	35
5-2.11	Wind Design.	36
5-3	HYDROSTATIC SYSTEM REQUIREMENTS.	36
5-3.1	General.....	36
5-3.2	Material.....	36
5-3.3	Panel Type.....	37
5-3.4	Slope.	38
5-3.5	ASTM Test Method.....	38
5-3.6	Hydrostatic Specifications.....	38
5-3.7	Recommended Hydrostatic Construction Details.....	38
5-4	HYDROKINETIC SYSTEM REQUIREMENTS.	38
5-4.1	General.....	38
5-4.2	Material.....	39
5-4.3	Panel Type.....	39
5-4.4	Flashing Details.	39
5-4.5	Slope.	40
5-4.6	Hydrokinetic Roofing Specifications.....	40
5-4.7	Recommended Hydrokinetic Construction Details.....	40

CHAPTER 6 RE-ROOFING REQUIREMENTS	43
6-1 OVERVIEW.	43
6-2 GENERAL CONSIDERATIONS.....	43
6-2.1 Terminology.....	43
6-2.2 Life Cycle Cost Analysis.	43
6-2.3 Low-sloped Versus Steep-Sloped Considerations.....	43
6-3 MESH REINFORCED ELASTOMERIC ROOF COATINGS (MREC).....	44
6-4 LOW-SLOPE ROOFING REMOVAL AND REPLACEMENT.....	45
6-4.1 Analysis of Existing System.....	45
6-4.2 Phenolic Foam Board Insulation.....	45
6-4.3 Testing for Asbestos Containing Materials (ACM).	45
6-4.4 Slope.	46
6-5 REPLACING SINGLE-PLY SYSTEMS.	46
6-6 LOW-SLOPE CONVERSIONS.....	46
6-7 TAPERED ROOF INSULATION SYSTEMS.	46
6-8 RECOVERING STEEP-SLOPE ROOFS.....	47
6-8.1 Historic Buildings.	47
6-9 METAL ROOFING.....	47
6-9.1 Metal Roofing Recover.	47
6-9.2 Metal Roofing Overbuild.	47
6-10 SPRAY APPLIED POLYURETHANE FOAM.....	48
6-10.1 Foam.....	49
6-10.2 Coating.	49
6-11 NEW TRUSSES AND DECKING.	49
6-12 SECONDARY PROTECTION.	49
6-13 CLIMATE/WEATHER CONSIDERATIONS.	49
6-13.1 Night Seals.	50
6-13.2 Upgrading Insulation.....	50
6-14 LOGISTICAL CONSIDERATIONS.....	50
6-14.2 System and Site Safety Considerations.....	51
6-14.3 Deck Replacement.	51
APPENDIX A REFERENCES	53

APPENDIX B BEST PRACTICES	59
B-1 INTRODUCTION	59
B-2 SUSTAINABILITY	59
B-2.1 21 TENETS OF SUSTAINABILITY	59
B-3 ROOFING SYSTEMS	61
B-3.1 LOW-SLOPE ROOF DRAINS	61
B-3.2 COVER BOARDS	61
B-3.3 COMMON METAL ROOF PANEL PROFILES	61
B-4 TEMPORARY ROOFS	63
B-5 ELECTRIC FIELD VECTOR MAPPING (EFVM)	64
B-5.1 HOW EFVM WORKS	64
B-5.2 LOCATING A BREACH IN THE MEMBRANE	64
B-6 RECYCLING	65
B-7 LIFE CYCLE ASSESSMENT	65
B-8 COOL ROOFING AND HEAT ISLAND ISSUES	65
B-9 GUTTERS AND DOWNSPOUTS	65
B-10 PARAPETS	66
B-11 DESIGN PROFESSIONAL QUALIFICATIONS	66
B-12 REROOFING	66
B-13 RECOVERING	67
B-14 TPO ROOFING	67
APPENDIX C GLOSSARY, ACRONYMS AND ABBREVIATIONS	69
APPENDIX D WARRANTIES	87
D-1 GENERAL	87
D-2 WARRANTY TYPES	87
D-2.1 MANUFACTURERS' WARRANTIES	87
D-2.2 GENERAL CONTRACTOR'S WARRANTIES (ONE TO FIVE YEARS)	88
D-2.3 ROOF INSTALLERS WARRANTY TO GENERAL CONTRACTOR (ONE TO TWO YEARS)	88
D-3 BONDING	89
D-4 WARRANTY REVIEW	89
D-5 CONTRACTOR'S WARRANTY	89

D-5.1	ROOF MANUFACTURER’S WARRANTY.....	89
D-5.2	WARRANTY CLAIM.	90
D-6	CLOSE-OUT.....	90
D-7	BUILDING MAINTENANCE.....	90
D-8	POST-CONSTRUCTION ROOF MODIFICATIONS.....	90
APPENDIX E QUALITY ASSURANCE CONSIDERATIONS		91
E-1	GENERAL.....	91
E-2	DESIGN.....	91
E-3	SPECIFICATIONS.....	91
E-3.1	ROOF SYSTEM.....	91
E-3.2	MAINTAINABILITY.....	91
E-3.3	SUBMITTALS.....	92
E-3.4	ROOF MANUFACTURER INSPECTION.....	92
E-3.5	WARRANTY SELECTION.....	92
E-3.6	PRE-INSTALLATION/PRE-CONSTRUCTION MEETING.....	92
E-3.7	MINIMUM INSTALLER QUALIFICATIONS.....	92
E-4	FIELD INSPECTION(S)/CQM.....	93
E-4.1	INSTALLATION.....	93
E-4.2	LEAKS.....	93
E-5	CLOSE OUT OF CONTRACT.....	93
APPENDIX F OTHER RESOURCES.....		95

TABLES

TABLE 1-1. RELATIONSHIP WITH NRCA MANUAL.....	2
TABLE 2-1. LOW-SLOPE ROOFING CONSTRUCTION DETAIL LIMITATIONS	20
TABLE 3-1. STEEP-SLOPE ROOFING CONSTRUCTION DETAIL LIMITATIONS ...	27
TABLE 5-1. HYDROKINETIC METAL ROOFING CONSTRUCTION DETAIL LIMITATIONS	41
TABLE 6-1. ALLOWABLE RECOVER OVER EXISTING ROOFING*	44

FIGURES

FIGURE B-1. COMMON METAL ROOF PANEL PROFILES AND CLIPS 62
FIGURE B-2. BULB SEAM ZIP RIB 63

CANCELLED

CHAPTER 1 INTRODUCTION

1-1 PURPOSE AND SCOPE.

Use this UFC in conjunction with the current editions of the National Roofing Contractors Association (NRCA) *Roofing Manuals* (NRCA Manual) and the NRCA technical bulletins and the Metal Building Manufacturers Association (MBMA) *Metal Roofing Systems Design Manual* (MBMA Roofing Manual) to provide specific design guidance for Military roofing projects. This UFC explains how to apply the NRCA Manual and the MBMA Roofing Manual to the design of Military projects (including **Army, Navy, and Air Force**).

1-2 APPLICABILITY.

This UFC is applicable to all military projects and planners, design professionals and contractors responsible for roofing planning, system design, installation, and maintenance. Family housing requirements may differ from the requirements stated herein. Where one Military Service's criteria vary from the other Services' criteria, it is noted in the text.

1-3 GENERAL BUILDING REQUIREMENTS.

UFC 1-200-01, "DoD Building Code (General Building Requirements)", provides applicability of model building codes and government-unique criteria for typical design disciplines and building systems, as well as for accessibility, antiterrorism, security, sustainability, and safety. Use this UFC in addition to UFC 1-200-01 and the UFCs and government criteria referenced therein.

1-4 CONTENTS.

Roofing design begins with system selection documented in this UFC, the NRCA Manual, and the MBMA Roofing Manual.

1-4.1 System Design.

The NRCA Roofing Manual and the MBMA Roofing Manual provide information regarding the design and construction of roofing systems. However, because of the emphasis on low life cycle cost, this UFC limits the applicability of certain techniques permitted by NRCA and MBMA. The NRCA Roofing Manual CD 2010 comprises five volumes (collectively referred to as NRCA Manual). Table 1-1 illustrates the relationship of this UFC with the NRCA Manual. Use the MBMA Roofing Manual for the design of metal roof systems in combination with the NRCA Manual.

TABLE 1-1. RELATIONSHIP WITH NRCA MANUAL		
UFC 3-110-03	Primary Design Criteria	Additional Criteria (Reference Only)
Chapter 2 - Low-slope Roofing Design Requirements (except metal roofing)	The NRCA Manual: Membrane Roof Systems – 2007 The NRCA Manual: Metal Panel and SPF Roof Systems – 2008 NRCA Construction Details CD – 2010	
Chapter 3- Steep-slope Roofing Design Requirements (except metal roofing)	The NRCA Manual: Steep-slope Roof Systems – 2009 NRCA Construction Details CD - 2010	
Chapter 4 – Roof System Related Sheet Metal Flashing	The NRCA Manual: Architectural Metal Flashing, Condensation Control & Reroofing – 2010	SMACNA Architectural Sheet Metal Manual
Chapter 5 – Standing Seam Metal Roofing Design Requirements	MBMA Roofing Manual (for Hydrostatic systems) NRCA Construction Details CD – 2010 (for Hydrokinetic systems)	The NRCA Manual: Metal Panel and SPF Roof Systems – 2008 & SMACNA Architectural Sheet Metal Manual
Chapter 6 - Reroofing Requirements	The NRCA Manual: Architectural Metal Flashing, Condensation Control and Reroofing	

1-4.2 Appendices.

Appendix A is a reference list. Appendix B provides background information and design best practices. Appendix C is the glossary of acronyms and abbreviations. Appendix D provides considerations on roof warranties. Appendix E provides quality assurance guidelines. Appendix F provides other resource documents.

1-5 BACKGROUND.

There are a variety of materials and roofing systems available. Satisfactory roofing performance comes from careful system and material selection, design, contract document preparation, specification, installation, and maintenance.

Roofing systems are exposed to the full brunt of the weather and can allow moisture intrusion or fail prematurely if not properly designed, installed, and maintained. Moisture intrusion can be costly, adversely affect the functions within the building, and result in roof system failure. Since modern roofing systems contain considerable thermal insulation, moisture intrusion lowers thermal efficiency and hinders energy conservation. Wet materials support fungus or mildew, cause deterioration of other roofing system components, and can emit odors leading to sick buildings and occupants.

1-6 SYSTEM SELECTION.

There are two starting points in roofing system selection.

1-6.1 New Construction.

In new construction, the roof system selection is an integral part of the overall building design and must take into account interior building usage and climate. For example, the building can be designed to prevent outward moisture drive, support heavy roof systems (such as garden roofs or paver systems), or sloped for the desired durability (life cycle cost benefit) and aesthetic considerations.

1-6.2 Existing Structures.

See Chapter 6 for more information on reroofing. When dealing with existing structures, weight, slope, existing and hazardous materials, and historic preservation may become constraints. For example, the thickness, weight, and reflectivity of the roof system has a major impact on roof/structure as already designed. Further, with an occupied building, construction noises, fumes, fire hazards, and roof access all take on increased importance.

1-7 SYSTEM TYPES.

For the purposes of this UFC, roofing is categorized as low-slope, steep-slope and metal roofing. Low-slope roofing systems are weatherproof membrane types of roof systems installed on slopes at or less than 3:12 (14 degrees). Steep-slope roofing systems are water-shedding types of roof coverings installed on slopes greater than 3:12 (14 degrees). Standing-seam metal roofing (SSMR) systems are either hydrostatic that are designed and constructed to be totally water resistive (like a roof membrane) or hydrokinetic that are not totally resistive to water intrusion and rely on slope to shed water.

1-8 GENERAL DESIGN REQUIREMENTS

The following requirements apply to all military roofing projects, regardless of system type:

1-8.1 Unified Facilities Guide Specifications (UFGS).

All roofing projects, including both design-build and design-bid-build, shall be designed consistent with this UFC and requirements of the applicable UFGS. Design-bid-build projects are required to utilize the applicable UFGS. Appendix A lists the applicable UFGS documents.

1-8.2 Wind Resistance Rating.

The designer of record shall determine wind uplift pressures and dimensions of the corners, perimeter, and field of the roof in accordance with ASCE-7, *Minimum Design Loads for Buildings and other Structures*. Delineate calculated values in the roof specification or drawings. Utilize independently tested and rated roof systems, such as Factory Mutual (FM), Underwriters Laboratory (UL), and Single Ply Roofing Industry (SPRI).

1-8.3 Thermal Expansion.

The design of the roof and building thermal expansion systems shall consider the selected roof system and shall comply with the roofing system manufacturer requirements.

1-8.4 Air and Vapor Barriers.

Coordinate the roofing design with UFC 3-101-01, "Architecture", which provides design criteria for the building envelope as a whole, including the roof. UFC 3-101-01 includes requirements for air and vapor barriers associated with roofing systems as well as the required $\frac{1}{1}$ calculation to determine the need for a vapor retarder and to verify that the vapor retarder has been positioned correctly in the roof assembly. Care must be taken to maintain the continuity of the roof vapor retarder, which is critical to its performance. Moist air leakage through poorly installed vapor retarders defeats their purpose and creates interior moisture problems.

1-8.5 Elimination, Prevention and Control of Fall Hazards.

Incorporate fall protection control measures in the design of roofs. Any part or component of the building, facility, structure or equipment requiring future maintenance work at roofs must incorporate in the design fall prevention methods or techniques to eliminate fall hazards during occupancy and when performing maintenance work. There is no safe distance from an unprotected edge. The preferred order of control measures or the hierarchy of controls is to eliminate the need to work at heights (design out fall hazards), followed by prevention (installing guards) and protection and control of fall hazards by identifying, designing and installing anchorages (hard points) for safe use of fall arrest equipment and systems. Select materials used in fall protection equipment for metal compatibility in order to minimize corrosion; type 316 stainless steel is recommended.

Elimination, prevention or control of fall hazards must comply with the provisions and requirements of American National Standards Institute, ANSI/ASSE Z359 Fall Protection Code, ANSI/ASSE A1264.1 Standard and DOL - 29 CFR Part 1910, Subpart D. For additional information, refer to *Building Design Elements for Enhanced Fall Protection for Construction and Maintenance Personnel: An NRCA Perspective*. For Navy projects comply with the *Department of the Navy Fall Protection Guide*.

1-8.6 Roof Hatches.

All buildings over two stories, excluding family housing, shall have a roof hatch with an interior ladder or building-attached exterior ladder for roof access. This includes metal roof overbuilds. Provide roof hatches with fully lined and insulated curbs. Coordinate curb height with tapered insulation heights; standard curb height is 12 in. (305 mm), 16, 18, and 24 in. (405, 455, and 610 mm) are available. The height of the roof curb shall be selected to provide 8 inch minimum curbing above the surface of the roof. Also, provide ladders up to the roof hatch, ladder up safety posts, and safety rails per OSHA requirements. Coordinate with UFC 4-010-01, "DoD Minimum Antiterrorism Standards for Buildings".

1-8.7 Skylights.

If skylights are included, specify fully lined and insulated curbs. Coordinate curb height with tapered insulation heights; standard curb height is 12 in. (305 mm), 16, 18, and 24 in. (405, 455, and 610 mm) are available. The height of the roof curb shall be selected to provide 8 inch minimum curbing above the surface of the roof. Skylight framing and flashing shall extend over and beyond the curb's vertical wall.

1-8.8 Cool Roofs.

∨If a cool roof is selected; meet the ASHRAE 90.1 Chapter 5 values for cool roofing. If a cool roof is not selected in climate zones 1-3, meet one of the exception requirements listed in ASHRAE 90.1 Chapter 5./2/

Mechanically fastened single-ply roof systems shall comply with the requirements for mechanically fastened single-ply systems in Chapter 2. Condensation on the underside of mechanically fastened systems can result in ice build-up in winter, mold growth on the facers, moisture dripping into the interior, and replacement of the roofs with less than four years of service. See Appendix B for more information.

1-8.9 Photovoltaic Systems – Rack Mounted Systems

If a photovoltaic system is selected, the contractor must adhere to the following guidelines:

- *Building Owners Guide to Roof-mounted Photo Voltaic Systems* published by NRCA.
- *Guidelines for Roof-mounted Photovoltaic Systems* published by NRCA.

∨PV supports must be permanently affixed stanchions that are anchored to the building structure.

Undertake installation of a photovoltaic roof system over roof systems with caution. Include the following when planning and designing PV systems located on new or existing roofs:

- Determine if the roof structure can handle the anticipated roof load increase. /2/
- Design to ensure that roof drainage is maintained considering the additional roof deflection due to load.
- Design the roof related details for anticipated roof replacement work. Coordinate with the photovoltaic system designer to anticipate and plan for future roof replacement.
- PV equipment on a roof places an entirely new set of roof protection requirements during initial installation and throughout the maintenance cycle. Specify a roof protection program to be applied during the PV system installation.
- Inspect and determine that the existing roof system has at least 10 years of service life remaining. If not, the existing roof shall be removed and a new replacement roof system designed in tandem with the photovoltaic system.
- If 10 years remaining service life remains, contact the warranty holder and involve them in the design of the intersecting details, required roof protection, re-inspections, and their requirements for maintaining the roofs guarantee.

1-8.10 Design Professional Qualifications.

Both design-build and design-bid-build projects with more than 15,000 ft.² (1400 m²) of roof area or that is defined as “critical use” or “mission critical” in the project DD Form 1391 shall have a Registered Roof Consultant (RRC) or a registered PE or RA that derives his or her principal income from roofing design on the quality control staff of the Design or Design-Build (DB) team.

1-8.11 Warranty Requirements.

Any new, permanent construction facility shall be designed and specified with a warranty that meets the following requirements:

- Has “no dollar limit,”
- Covers full system water-tightness,
- Is from the single source manufacturer, and

- Has a minimum duration of 20 years.

Manufacturers' warranties that require periodic inspections or repairs at the Government's expense to maintain the warranty are not permitted. The warranty terms, exclusions, and limits must be enumerated in the specifications and require that all roof curbs and penetration flashings \1\ (these include snow guard and lightning protection attachments) /1/ integrated into the roof system are covered under the warranty. For additional background on warranties, refer to Appendix D.

1-8.12 Roof Information Card.

Per the UFGSs for each roof installation, furnish a typewritten information card for facility records and a card laminated in plastic and framed for interior display at roof access point.

CANCELLED

This Page Intentionally Left Blank

CANCELLED

CHAPTER 2 LOW-SLOPE ROOFING DESIGN REQUIREMENTS

2-1 GENERAL.

The NRCA Manual provides a wide range of information for design and construction of low-slope roofing assemblies. This chapter does not address low-slope metal roofing (see Chapter 5). This chapter reinforces particularly salient information with regard to military use or limits the applicability of certain techniques in the NRCA Manual. Where contents of the NRCA Manual are acceptable without modification, those sections are not mentioned herein.

2-2 DESIGN-BUILD.

Because of the wide variety of materials available and the variation in quality in similar materials, design-build contracts for low-slope roofing systems must name the specific desired low-slope roofing system (BUR, Modified Bitumen, MREC, EPDM, etc.) and identify relevant performance requirements to be provided under the contract. It is not sufficient to simply specify a low-slope roofing system per this UFC.

2-3 GENERAL LOW-SLOPE ROOFING REQUIREMENTS.

2-3.1 Positive Drainage.

The minimum slope for construction of new buildings is 1/2:12 to achieve positive drainage. Consult with a plumbing engineer to determine the appropriate number of roof drains and the size of drain pipes. Refer to the International Plumbing Code (IPC), Chapter 11, Storm Drainage. Retrofit drains are not permitted.

2-3.2 Roof Curb Heights.

Curbs height shall be a minimum of 8 in. (200 mm) above the roof surface, but shall not be less than 6 in. (150 mm) above the high point of a cricket. Roofs with slope may need additional crickets on the upslope side of all non-round penetrations to assure positive drainage around equipment. Crickets are required on the upslope side of all penetrations greater than 24-in. (610-mm) wide

2-3.3 Horizontal Roof Top Duct Work.

Horizontal roof-top ductwork shall have a minimum clearance of 18 in. (455 mm) above the roof plane to ensure ease of re-roofing. Ductwork larger than 48-in. (1220-mm) wide will require a minimum clearance of 24-in. (610-mm) and shall be coordinated with the HVAC engineer.

2-3.4 Snow and Ice.

Over-the-eaves drainage in cold climates can be problematic if snow and ice issues are not addressed early in the design process. Issues that designers shall address are

contained in the Cold Regions Research & Engineering Laboratory (CRREL) report MP-01-5663, *Minimizing the Adverse Effects of Snow and Ice on Roofs*.

Locate downspouts to avoid ice build-up on pedestrian circulation paths.

2-3.5 Hail.

Some geographical areas of the United States are more prone to severe hail events. Roof assemblies shall be capable of resisting impact from reasonably expected hail storms for a given geographical area in accordance with IBC-2009 Paragraph 1504.7. Typical enhancements include a thicker membrane combined with a rigid coverboard directly below the membrane.

Owners of critical facilities, such as hospitals, schools, computer centers, airports and sensitive government buildings have come to realize the importance of installing a hail resistant roof assembly over critical facilities. Hail-resistant roof assemblies shall incorporate high-density cover boards when fully-adhered roof covers are specified. Examples of roof covers that have been shown to perform well in hail prone areas (up to 2-in. (50-mm) hail stone size) include the following:

- Aggregate surfaced built up roofing
- Aggregate surfaced modified bitumen
- 1\ /1/
- Fully adhered 90 mil (2.28 mm) EPDM
- Granule or smooth with coating polyester reinforced modified bitumen

2-3.6 Vegetative Roofing Systems.

Vegetative roof systems are a roof area of plantings/landscaping installed above a waterproofed substrate at any building level that is separated from the ground beneath by its manmade structure. A vegetative roof system consists of a waterproofing system and its associated components such as protection course, root barrier, drainage layer, thermal insulation and aeration layer, and an overburden of growth medium and plantings. See *NRCA Vegetative Roof Systems* for additional information.

Vegetative roof systems must be installed over newly installed roof systems and cannot be installed over existing roof systems. Knowledgeable selection of compatible building materials, quality vegetative roof system materials, and systems that will withstand the conditions of the location where a building is located are vital to a quality vegetative roof assembly design. Properly prepared contract documents with accurate drawings and details are essential. Vegetative roof systems shall be designed by an RRC or a registered PE or RA that derives his or her principal income from roofing design. Test the final assembly with a 48-hour water test per ASTM D5957 and/or using an electric field vector mapping (EFVM) system (see Appendix B for more info on EFVM).

Recommended waterproof membrane systems for use in vegetative roofs include:

- Hot fluid applied modified asphalt membrane, fabric reinforced – 215 mils minimum thickness
- Atactic polypropylene polymer (APP) and Styrene butadiene styrene (SBS) polymer modified bitumen sheet membrane, 2-layer minimum
- 1\ /1/
- PVC reinforced – 72 mils (1.82 mm) minimum thickness

2-4 ROOF DECKS.

2-4.1 Deck Slope.

For new construction, the minimum slope noted in Chapter 2, Positive Drainage, must be accomplished in the structural deck.

2-4.2 Types of Roof Decks.

2-4.2.1 Steel Decks.

Steel roof decks are common on military facilities. When properly designed, they provide an economical and dependable roof deck. They are lightweight and are particularly useful where relatively large clear spans are desired. Mechanically attach roof insulation for this type of roof deck. Design to prevent mechanical fasteners from backing out enough to disengage the deck. In addition, the design of the roof insulation must be tolerant of a small degree of fastener back out. Two layers of insulation are required. Depending on wind resistance requirements, all layers of insulation may be mechanically fastened or the bottom layer may be mechanically fastened and the top layer adhered. Wood fiberboard may not be in direct contact with steel decks.

2-4.2.2 Structural Concrete Decks.

Structural precast and poured-in-place concrete roof decks are also commonly used on military projects. They are heavy and are best suited to roof decks with relatively short spans. Use mechanically fastened insulation only when fully adhered roof systems will not meet the required wind uplift resistance. Due to the inherent moisture in the concrete, proper drying time is required. Ensure during system selection and installation that adequate bonding takes place between the roof system and the deck. Prior to installing any roof system on a concrete deck, conduct a test per ASTM D4263. The deck is acceptable for roof system application when there is no visible moisture on underside of plastic sheet after 24 hours.

2-4.2.3 Wood-Plank and Structural Wood-Panel Decks.

Wood-plank and structural wood-panel decks were used in the past on many military facilities. Generally, this material may only be used on small buildings or in reroofing

when the existing material is in fair or better condition. Use of this material on new buildings must be supported with strong arguments demonstrating that neither steel nor structural concrete decks fulfill the specific functional requirements.

2-4.2.4 Cement-Wood Fiber Deck Panels.

Cement-wood fiber deck panels have limited utility due to concerns about moisture susceptibility. This type of deck shall not be used for new construction.

2-4.2.5 Lightweight Insulating Concrete Decks.

Lightweight insulating concrete decks have limited utility due to its hygroscopic nature and difficulty of reroofing. Do not use this type of roof deck for new construction.

2-4.2.6 Poured Gypsum Concrete Decks.

Poured gypsum concrete decks have limited utility due to difficulty in attaching membranes to the deck and difficulty in repair. Do not use this type of roof deck for new construction.

2-4.2.7 Precast Gypsum Panel Decks.

Precast gypsum panel roof decks have been used on many military facilities. However, where membrane leaks have occurred, these roof decks pose a safety hazard due to structural instability. Do not use this type of roof deck for new construction.

2-4.2.8 Thermosetting Insulating Fills.

Thermosetting insulating fills have limited utility. Do not use this type of roof deck for new construction.

2-5 RIGID BOARD ROOF INSULATION.

2-5.1 General.

Roof insulation is a very cost-effective means of reducing energy consumption. Depending on climate and the type of membrane selected, the position of the insulation in the roof system greatly affects the performance of the roof system. Insulation system shall be selected and designed to meet the requirements in UFC 3-101-01, "Architecture", and \1\ UFC 1-200-02, "High Performance and Sustainable Building Requirements". /1/

2-5.2 Types of Roof Insulation.

2-5.2.1 Cellular Glass Insulation.

Cellular glass roof insulation is not widely used due to its high cost. It is most commonly used in cold storage facilities and other areas where excessive amounts of moisture would degrade the insulating capabilities of other types of insulation.

2-5.2.2 Perlite Board Insulation.

Perlite board insulation is commonly used and may be specified where factors other than insulating efficiency per unit thickness are the primary design considerations. It is particularly useful in roof assemblies where fire resistance is of primary concern and the potential for water vapor intrusion is limited. Perlite board shall not be used in high-wind areas.

2-5.2.3 Polyisocyanurate Foam Board Insulation.

Polyisocyanurate foam board is the most commonly used roof insulation. It is often specified where insulating ability is the primary design consideration. The minimum compressive strength of polyisocyanurate foam board shall be 25 psi (172 kPa).

2-5.2.4 Polystyrene Board Insulation.

Polystyrene board roof insulation is used by the military and is made in two types: expanded polystyrene board (EPS) and extruded polystyrene board (XPS). In terms of moisture resistance and insulating capability, XPS is superior to EPS. It is also more expensive but appropriate for use in inverted membrane systems and cold storage facilities. Do not use polystyrene in direct contact with hot mopped systems. It is typically necessary to use underlayment board and cover board with polystyrene insulation in order to provide for necessary fire interior and exterior ratings and membrane adhesion properties, except when used as part of a loose-laid, inverted roof system assembly on concrete deck. When polystyrene is used on the interior of a building, it must be encased with a fire resistive material.

2-5.2.5 Composite Board Insulation.

Composite board roof insulation may be specified where a multiple layer type of insulation does not satisfy all design requirements, and where there are cost savings available from reducing the number of construction operations needed to install two different kinds of roof insulation. Single layer applications shall be limited when possible.

2-5.2.6 Phenolic Foam Board Insulation.

Phenolic foam board insulation causes severe corrosion when in contact with steel roof decks. It is no longer manufactured in the United States. Phenolic foam board insulation shall not be specified for use.

2-5.2.7 Tapered Insulation Systems.

Tapered rigid board roof insulation systems are more expensive per square unit than non-tapered insulation. As a result, do not use tapered insulation to create the primary slope in new construction. Use tapered insulation in crickets and saddles to ensure positive drainage when adequate drainage already exists in the roof deck as a whole. The slope of crickets and saddles shall be twice that of the main slope.

2-6 COVER BOARDS.

2-6.1 General.

Coverboards installed directly below the roof membrane shall be used within all roof assemblies except single-ply ballasted roof systems. Coverboards provide the following functions:

1. Separate incompatible material
2. Minimize the effects of thermal drift; and
3. Protect the thermal insulation and provide a rigid support for the roof membrane.

2-6.2 Types of Cover Boards.

2-6.2.1 Glass Mat Silicon-modified Gypsum Boards.

Provides improved impact and moisture resistance to roof covers and improved fire resistance.

2-6.2.2 High Density Wood Fiber.

Provides improved impact resistance to roof covers, but is hydroscopic in nature.

2-6.2.3 Paper-faced Gypsum Board.

This shall not be used as a cover board.\2\

2-7 SUITABLE ROOF MEMBRANES.

The NRCA Manual discusses all available roof membranes; however, some membranes do not provide the long-term performance requirements for military buildings. Some new products may not be judged suitable because of the lack of proven performance. Other membrane systems may not be suitable because experience has shown a lack of cost effectiveness over the required life cycle.

Generally, low-slope roof membranes that are suitable for use by the military are limited to the following:

1. Asphalt built-up roof (BUR) membranes
2. Styrene butadiene styrene (SBS) or atactic polypropylene polymer (APP) modified bitumen (MB) membranes
3. Ethylene propylene diene monomer (EPDM) single-ply membranes
4. Weldable thermoplastic polyvinyl chloride (PVC) single-ply membranes

5. Weldable Thermoplastic Polyolefin (TPO)
6. Spray applied polyurethane foam (SPF) membranes
7. Hot rubberized reinforced fluid-applied membranes./2/

2-8 GUIDANCE FOR ROOF MEMBRANES.

This Section provides requirements and considerations for the design and construction of the above roof membrane types. \2\ Consider the use of any membrane type for which there is not a corresponding UFGS on a case-by-case basis, subject to approval by the project manager.

2-8.1 Asphalt BUR Membranes.

/2/ BUR systems have broad applicability for dependable low-slope roof systems with low service life cost. Consider this roof system unless it can be shown that it fails to meet important design criteria. Positive attributes of BUR membranes include:

- Durability with long service life
- Low maintenance
- Well-understood maintenance procedures

However, the success of this roofing system is based upon sound installation techniques accompanied by suitable quality control. Quality control can be influenced by the warranty. More information on warranties may be found in Appendix D and more information on quality assurance may be found in Appendix E.

2-8.1.1 Cant Strips.

Provide cant strips for all built-up roof systems.

2-8.1.2 Fiberglass Mat Material.

BUR systems must use fiberglass mat material and no less than three-ply or as limited by the UFGS.

2-8.1.3 Roof Vents.

\1\ Ventilating base sheets are required on all concrete roof deck systems. Roof vents are not permitted for new construction. /1/

2-8.1.4 Types of BUR Membrane Surfacing.

The allowable types of top surfacing for BUR membranes are granulated modified bitumen cap sheet and aggregate.

2-8.1.4.1 Granulated Modified Bitumen Cap Sheet.

Ceramic granules reduce the temperature effect on BUR systems. However, as granules are lost, degradation due to ultraviolet (UV) radiation will negatively affect performance. Longevity of these systems on average is not as great as aggregate surfaced BUR systems.

2-8.1.4.2 Aggregate Surface.

The most common type of BUR surfacing is aggregate embedded in a bituminous flood coat. The thickness of 400 lb. (180 kg) gravel surfacing per square of roofing is 0.5 to 0.75 in. (12 to 18 mm). This surfacing allows the temperature of the BUR membrane to remain somewhat cooler than mineral surfaced cap sheet BUR systems. Aggregate surface BUR systems tend to have a longer expected service life than mineral surfaced cap sheet BUR systems because of lower membrane temperature and due to protection of the membrane by the aggregate.

Aggregate surfaced roof system coverings shall be designed and installed in accordance with the IBC Code and Table 1504.4 based on the exposure category and basic wind speed at the building site. The aggregate shall comply with the ASTM D1863 No. 6 aggregate in hurricane prone regions as defined by the IBC Section 1609.2. Aggregate is not permitted when the basic wind speed is 100 mph or greater or at airfields.

2-8.2 MB Membranes.

MB roofing systems have low maintenance cost, and must be considered when long service life is required. The polymers used to modify the asphalt bitumen improve the performance characteristics of the asphalt. The addition of polymers increases low temperature flexibility and high temperature stability. MB membranes are reinforced with fiberglass, polyester, or a combination of both. MB membranes must have at least two-ply or as specified by the UFGS.

2-8.2.1 Polymer Modifiers.

The two major types of bitumen modifiers used are an elastomeric Styrene Butadiene Styrene (SBS) polymer and a thermoplastic Atactic Polypropylene (APP) polymer. SBS systems are usually applied by hot mopping asphalt; however, torch varieties of SBS membranes are gaining prominence. Some SBS products are applied with cold adhesive or torching. APP systems are typically applied with propane torches, which necessitate special requirements for safe handling and storage. All torch-applied MB systems will utilize non-combustible cant strips at parapets and curbs. Only non-combustible materials shall be used for torch-applied systems, including the roof deck, parapets, and structure. If the torch method is used, specify that the roofing contractor conduct an on-site two-hour fire watch after the last torch is extinguished. Provide access to the building interior for the fire watch personnel.

2-8.2.2 MB Membrane Surfacing.

The three common types of surfacing used for the top sheet of MB systems are granulated surfaced, metal foil faced, and coated smooth surfaced.

2-8.2.2.1 Granulated Surface.

Ceramic granules reduce the temperature effect on MB systems. However, as granules are lost, degradation due to ultraviolet (UV) radiation will negatively affect performance. Longevity of these systems on average is not as great as aggregate surfaced MB systems.

2-8.2.2.2 Metal Foil Surface.

Metal foils surfaced MB roof systems may be used to achieve solar reflectivity or to improve fire resistance.

2-8.2.2.3 Smooth Surface.

Uncoated smooth surfaced systems are not permitted. Smooth surface membranes must be factory coated for heat reflection and UV protection.

2-8.3 Thermoset EPDM Membranes.

EPDM roof membranes provide predictable serviceability in roof systems in all climates. The minimum sheet thickness shall be 90 mil. All lap seams shall be fabricated with 6-in. (150 mm) seam tape and stripped-in with self-adhering, semi-cured EPDM cover strips.

\1\ /1/

2-8.3.1 Mechanically fastened EPDM Systems.

Mechanically fastened EPDM are not permitted.

2-8.3.2 Fully Adhered EPDM Systems.

Fully adhered EPDM systems do not allow billowing of the membrane and are the preferred method of EPDM installation.

2-8.3.3 Ballasted EPDM Systems.

Ballasted EPDM roof systems use larger sheets with factory made seams, which are proven superior to field seams. The downside of ballasted roof systems is the need for stone ballast or concrete pavers, and the increased difficulty in detecting sources of leaks. The ballast is relatively heavy at 10 to 12 lbs. per sf. (49 to 59 kg per sm) and may affect the structural system. All ballasted systems shall comply with ANSI/SPRI RP-4, *Wind Design Standard for Ballasted Single-ply Roofing Systems*. \2\

2-8.4 Weldable Thermoplastic Membranes.

Thermoplastics are materials that soften when heated and regain their physical properties upon cooling. Weldable thermoplastic membranes are appealing as roofing systems because when the seams are properly heat welded they can exhibit seam strengths comparable to the membrane sheet. Weldable thermoplastic membranes are available in many different colors and are often rated as a cool roof. to reduce energy consumption. While the material costs are higher than bituminous-based roofing, labor costs are generally lower. Properly constructed weldable thermoplastic membrane systems may last 15 years or more. Thermoplastic systems permitted in DON are Polyvinyl Chloride (PVC), and Thermoplastic Polyolefin (TPO). Both systems have been used successfully for over 15 years. The minimum thickness of weldable thermoplastic membranes shall be 60 mils (1.52 mm) for PVC and 72 mils for TPO.

2-8.4.1 Mechanically Fastened Weldable Thermoplastic Systems.

Mechanically fastened weldable thermoplastic systems allow some billowing of the roof membrane ; however, this is greatly limited by reinforcement fabrics. Cool roofs in ASHRAE Climate Zones 4-8 shall be fully adhered and not mechanically fastened. Mechanically fastened TPO is not allowed.

2-8.4.2 Fully Adhered Weldable Thermoplastic Systems.

Fully adhered weldable thermoplastic systems do not allow billowing of the roof membrane and are the preferred method of installation.

2-8.5 Thermoplastic Polyolefin (TPO).

TPO membranes are typically white in color and, as a thermoplastic, the seams are heat welded. Specify TPO with 72 mil (1.8 mm) minimum thickness.

Mechanically fastened systems are popular but are restricted to the 'rhino bond' system and therefore not allowed due to lack of competition. Fully adhered systems are required. A cover board shall be utilized in all systems.

2-8.6 Hot Rubberized Reinforced Fluid-applied Membranes.

Hot rubberized reinforced fluid-applied membranes are only permitted when designed and shop drawings reviewed by an RRC or a registered PE or RA that derives his or her principal income from roofing design. Further, the membrane shall be applied to a minimum 4-inch (100-mm) thick concrete surfacing.

2-9 LOW-SLOPE CONSTRUCTION DETAILS.

Use the NRCA Construction Details CD - 2010 construction details as applicable, except as noted in Table 2-1 in this UFC. For details pertaining to low-slope metal

roofing, refer to Chapter 5 of this document. Design documents for individual projects must supplement these standard details with additional information related to closures, terminations, transitions, corners, lap and joint conditions, materials interface, sealant requirements, and other project specific conditions. Address all flashing requirements with a complete set of detail drawings. Minimize the use of pitch (or pourable sealer) pans.

12\

CANCELLED

TABLE 2-1. LOW-SLOPE ROOFING CONSTRUCTION DETAIL LIMITATIONS	
NRCA Detail	Comments
BUR-4	For use only with concrete parapet walls where installation of a reglet and counter flashing inserted into the reglet joint is not possible.
BUR 4S	For use only with concrete parapet walls where installation of a reglet and counter flashing inserted into the reglet joint is not possible.
BUR-7A	Do not use.
BUR-7AS	Do not use.
MB-4	For use only with concrete parapet walls where installation of a reglet and counter flashing inserted into the reglet joint is not possible.
MB-4S	For use only with concrete parapet walls where installation of a reglet and counter flashing inserted into the reglet joint is not possible.
MB-7A	Do not use.
MB-7AS	Do not use.
TS-4	For use only with concrete parapet walls where installation of a reglet and counter flashing inserted into the reglet joint is not possible.
TS4S	For use only with concrete parapet walls where installation of a reglet and counter flashing inserted into the reglet joint is not possible.
TS-5	Termination Bar holes must be slotted for expansion and contraction.
TS-5S	Termination Bar holes must be slotted for expansion and contraction.
TS-7A	Do not use.
TS7AS-	Do not use.
TP-4	For use only with concrete parapet walls where installation of a reglet and counter flashing inserted into the reglet joint is not possible.
TP-4S	For use only with concrete parapet walls where installation of a reglet and counter flashing inserted into the reglet joint is not possible.
TP-7A	Do not use.
TP-7AS	Do not use.
SPF-(FB)-1	Fleece-backed membrane not applicable.
SPF-(FB)-2	Fleece-backed membrane not applicable.
SPF-(FB)-3	Fleece-backed membrane not applicable.
SPF(FB) -4	Fleece-backed membrane not applicable.
SPF(FB)-5	Fleece-backed membrane not applicable.
SPF(FB)-6	Fleece-backed membrane not applicable.
SPF(FB)-11(FB)&18(FB)	Fleece-backed membrane not applicable.
SPF-4	For use only with concrete parapet walls where installation of a reglet and counter flashing inserted into the reglet joint is not possible.
SPF-4S	For use only with concrete parapet walls where installation of a reglet and counter flashing inserted into the reglet joint is not possible.
SPF-5	Termination Bar holes must be slotted for expansion and contraction.
SPF-5S	Termination Bar holes must be slotted for expansion and contraction.
SPF-7A	Do not use.
SPF-7AS	Do not use.

CHAPTER 3 STEEP-SLOPE ROOFING DESIGN REQUIREMENTS

3-1 GENERAL.

Steep-slope roofs provide more efficient drainage than low-slope systems and, as a result, are less likely to leak. This chapter does not cover steep-slope metal roofing (see Chapter 5). Chapter 3 limits the applicability of certain techniques permitted by the NRCA to focus on long life cycle military requirements. Where contents of the NRCA Manual are acceptable without modification, those sections are not mentioned.

3-2 DESIGN-BUILD.

Because of the wide variety of materials available and the variation in quality in similar materials, design-build contracts for steep-slope roof systems must name the specific roofing material desired and identify relevant performance requirements to be provided under the contract. It is not sufficient to simply require a steep-slope roof system per this UFC.

3-3 GENERAL STEEP-SLOPE ROOFING REQUIREMENTS.

3-3.1 Self-Adhering Underlayment.

At a minimum, the self-adhering polymer-modified asphalt bitumen membrane underlayment shall be placed as follows:

- At a minimum in ASHRAE Climate Zones 4 and above, place from the eave roof edge to 36 in. (915 mm) past the interior face of the exterior wall on rafter lengths of up to 30 ft. (9.1 m). On rafter lengths between 30 and 45 ft. (9.1 and 13.7 m) place 72 in. (1830 mm) past the interior face. On rafter lengths greater than 45 ft. (13.7 m) place 98 in. (2490 mm) past the interior face.
- 36 in. (915 mm) out from the centerline of all valleys
- 24 in. (610 mm) out from side walls and 8 in (200 mm) vertically up sidewalls
- Over roof curbs and 24 in. (610 mm) out from each side of the curb
- 18 in. (455 mm) out from plumbing vents
- 36 in. (915 mm) along all rake roof edges

Additionally, locate self-adhering polymer-modified asphalt bitumen membrane where moisture intrusion due to snow and ice build-up and/or where frequent infiltration is anticipated. Coordinate self-adhering underlayment design with other roof system vapor barriers (see Chapter 1, Air and Vapor Barriers) to prevent creating two vapor barriers that will not allow the roof system to breath.

3-3.2 Overhangs.

The roof deck and the roof panels shall extend a minimum of 8 in. (200 mm) beyond the exterior wall, with 12 to 24 in. (305 to 610 mm) preferred.

3-3.3 Curb Heights.

Provide crickets on the up-slope side of all non-round penetrations on steep-slope roofs. Curbs shall be a minimum of 8 in. (200 mm) above the roof surface, but shall not be less than 6 in. (150 mm) above the high point of a cricket.

3-3.4 Metal Flashing.

Flashing (excluding gutters, copings, and expansion joints) must be one of the following materials:

- Pre-finished aluminum at a minimum thickness of 0.050 in. (1.30 mm) and shall not come in direct contact with mortar,
- Aluminum at a minimum thickness of 0.050 in. (1.30 mm) and shall not come in direct contact with mortar,
- Copper at a minimum thickness of 16 ounces (454 g),
- Stainless steel at a minimum thickness of 24 ga. (0.64 mm),
- Pre-finished galvanized (G90) at a minimum 24 ga. (0.70 mm) may be used in locations expecting significant physical abuse or a building/roof life less than 15 years,
- Pre-finished 55% AlZn (such as Galvalume) at a minimum 24 ga. (0.70 mm) may be used in locations expecting significant physical abuse or a building/roof life less than 15 years,
- Galvanized steel (G90) at a minimum 24 ga (0.70 mm) may be used for a building/roof life less than 10 years,
- 55% AlZn (such as Galvalume) at a minimum 24 ga (0.70 mm) may be used for a building/roof life less than 10 years, and
- Tin-Zinc Alloy coated copper 16 oz. (454 g) minimum may be used at historical sites.

In extreme environments, also refer to *Materials Selection Guide for Army Installations Exposed to Severely Corrosive Environments*.

3-3.5 Gutters and Downspouts.

Prepare calculations to determine the minimum drainage requirement using the calculation method as specified in the Sheet Metal and Air Conditioning Contractors National Association's (SMACNA) Architectural Sheet Metal Manual (current edition).

Obtain the rainfall component for the project site from UFC 3-400-02, "Design: Engineering Weather Data". Locate downspouts and leaders to preclude water and ice build-up on pedestrian paths.

3-3.6 Snow and Ice Considerations.

Most steep roofs drain over their eaves. Some low-slope roofs also drain to eaves, but most drain internally. Over the eaves drainage in cold climates can be problematic if snow and ice issues are not considered early in the design process. Consider design contained in the CRREL report MP-01-5663, *Minimizing the Adverse Effects of Snow and Ice on Roofs*; CRREL MP 5106, *Attic Ventilation Guidelines to Minimize Icings at Eaves*; and CRREL MP 5420, *Ventilating Cathedral Ceilings to Prevent Problematic Icings at their Eaves*.

3-3.7 Hail Resistance.

Roof assemblies shall be capable of resisting impact from reasonably expected hail storms for a given geographical area. In geographical areas of the United States prone to severe hail events, specify impact resistant shingles conforming to UL 2218/ASTM 2218 Class 4 (there are four classes).

3-3.8 Fall Protection.

All roofs with a slope greater than 3:12 shall have permanently installed fall protection per Chapter 1.

3-4 ASPHALT SHINGLES.

Asphalt shingles provide versatile, low-cost steep-slope roofing. As with all roof system selections, a life cycle cost analysis must be performed to determine the appropriate system for a specific project application. To ensure a quality consistent with other roofing systems the following requirements apply.

3-4.1 Wind Pressure.

In areas where the roof deck design is required to resist wind pressures of 45 lbs./ft.² (220 kg/m²) or more as determined by ASCE 7, the manufacturers' high wind design and installation requirements apply. This may include requiring six nails per shingle as determined by applicable building code, wind speed, slope, and building height.

3-4.2 Perimeter Drip Edge.

Perimeter drip edges are required for all steep-slope roof systems.

3-4.3 Valley Flashing.

Open metal valleys are the preferred system. Woven valleys are allowed on family housing only. Closed cut valley flashing may be used with architectural-grade shingles.

3-4.4 Underlayments.

The use of underlayment requires a continuous substrate to support the underlayment material. The underlayment shall be a minimum 30-pound, non-perforated organic asphalt saturated roofing felt meeting ASTM D226/D226M Type 2 or ASTM D4869/D4869M Type 4. The underlayment shall be applied over the entire roof deck and the self-adhering underlayment before or during the application of shingles. On roofs with a slope less than 4:12, apply two layers of underlayment with staggered side laps. Underlayment(s) shall be vapor-permeable unless it is intentionally designed to perform as a vapor retarder. An underlayment performs several functions:

- Weather protection for a limited time until a roof covering is installed.
- A secondary weatherproofing barrier should moisture infiltrate the asphalt shingles
- Separation between a roof covering and a substrate

In addition, underlayments generally are necessary with asphalt shingle roof systems for the following reasons:

- To comply with the applicable building code
- To maintain a Class A, B or C fire rating for a roof assembly
- To meet the requirements of the manufacturer for a material or system warranty

3-5 TILE ROOFING.

Clay and standard concrete tiles are the preferred tile system. Avoid using lightweight concrete tiles unless required for structural and aesthetic reasons. Use tile for reroofing projects to match existing when required on projects included on the National Register of Historic Places. For other historic reroofing projects, consult with the State Historic Preservation Office (SHPO) or equivalent host nation organization prior to commencing design work. The following requirements apply to tile roofing.

3-5.1 Slope.

Tile roofing systems shall not be placed on slopes greater than 6:12.

3-5.2 Fasteners.

All roof tiles shall be anchored using stainless steel or copper fasteners, 1-in. (25 mm) engagement in the substrate. Fastener heads shall be of sufficient diameter to prevent pull over of tile. Galvanized fasteners may not be used. Do not use wire ties to fasten tiles to the roof deck.

3-5.3 Flashing.

Flashings must be copper, lead, or stainless steel.

3-5.4 Perimeter Drip Edge.

Perimeter drip edges are required for all steep-slope roof systems.

3-5.5 Batten Boards.

Provide batten boards under tiles in cold climates to assure the coldest roof surface possible. Batten board applications also promote ventilation and drying of tile and under tile. Battens should be considered in all climates where tiles can be lug-hung.

3-5.6 Snow Guards.

Evaluate the need for snow guards and/or fences in cold climates, considering roof slope and anticipated snowfall, and provide the guards over entryways, pedestrian walkways, and parking areas. Also, provide where one roof eave is above another roof.

On roofs with slopes of 10:12 or greater, install a snow fence at the eave. Continuous snow guards around the building perimeter and above all roof penetrations are strongly recommended in ASHRAE Climate Zones 4 and above.

3-5.7 Roof Cement.

Use polymer modified bitumen roof cement.

3-5.8 Self-Adhering Underlayment.

Use a self-adhering modified bitumen membrane installed per Chapter 3, General Steep-slope Roofing Requirements, Self-Adhering Underlayment. Use high temperature polymer modified bitumen membrane as underlayment at high altitudes and the extreme south and southwest regions of CONUS.

3-5.9 Felt Underlayment.

Use non-self-adhering polymer modified bitumen membrane as felt underlayment installed per Chapter 3, Underlayments.

3-6 SLATE ROOFING.

Slate roofing materials are extremely long lasting but expensive. Consider slate for new construction only when it is required for architectural compatibility with adjacent buildings. Use slate for reroofing projects to match existing when required on projects included on the National Register of Historic Places. For other historic reroofing projects, consult with SHPO or equivalent host nation organization prior to commencing design work. In order to receive full value for the use of slate roofing, other building

materials shall provide comparable longevity. A structural analysis must be made prior to installing slate where other roofing systems were used before. Comply with the National Slate Associations, *Slate Roofs: Design and Installation Manual*. Only slate conforming to ASTM C406/C406M *Standard Specification for Roofing Slate* may be used.

3-6.1 Roof Cement.

Use polymer modified bitumen roof cement.

3-6.2 Self-Adhering Underlayment.

Use a self-adhering modified bitumen membrane installed per Chapter 3, General Steep-slope Roofing Requirements, Self-Adhering Underlayment.

3-6.3 Felt Underlayment.

Use non-self-adhering polymer modified bitumen membrane as felt underlayment installed per Chapter 3, Underlayments.

3-6.4 Snow Guards and Fences.

Evaluate the need for snow guards and/or fences in cold climates, considering roof slope and anticipated snowfall; provide the guards over entryways, pedestrian walkways, and parking areas. Also, provide where one roof eave is above another roof.

Continuous snow fences around the building perimeter and above all roof penetrations are strongly recommended in ASHRAE Climate Zones 4 and above. On roofs with slopes of 10:12 or greater, install a continuous snow fence at the eave.

3-7 OTHER STEEP-SLOPE ROOFING.

Other roofing materials are presented in the NRCA Manual. Designers who chose to specify these materials must research the products and demonstrate their life-cycle cost benefits.

Wood roofing materials shall not be used.

3-8 STEEP-SLOPE CONSTRUCTION DETAILS.

Use the NRCA Manual Volume 4 details as applicable, except as noted in Table 3-1 in this UFC.

TABLE 3-1. STEEP-SLOPE ROOFING CONSTRUCTION DETAIL LIMITATIONS	
NRCA Vol 4 Details & Figures	Comments
Shingles	
Figure 1, page 26	Do not use.
Figure 25, page 45	Do not use.
Figure 32, page 48	Use only when building life expectancy is less than 20 years.
Figure 35B, page 49	Do not use.
Figure 35C, page 49	Do not use.
Asphalt Shingles	
SM-44-1	Flashing to be 200 mm (8 in.) minimum height.
SM-47	Flashing to be 200 mm (8 in.) minimum height.
SM-46-1	Must have an integral (welded) cricket attached to curb for roof penetrations greater than 305 mm (12 in.) (i.e. no dead valleys wider than 305 mm (12 in.)).
ASPH 1	Eave and rake flashing to extend a minimum of 305 mm (12 in.) under shingles.
ASPH 10	Closed cut valleys strongly discouraged (woven or open valley encouraged).
Clay Tile	
Figure 9, page 102	Do not use flat interlocking, French interlocking, plain tiles.
Figure 10, page 103	Do not use unless matching existing.
Figure 21, page 111	Do not use.
Slate Tile	
	Roof Design Professional to design or review details, consult National Slate Associates Manual.
Wood Shakes	
	Not allowed.
Wood Shingles	
	Not allowed.
Sheet Metal	
SM 11-18	Sealant beneath cover plate to be high quality non-curing butyl, Depth of face side metal to be 200 mm (8 in.) minimum
SM 14,16,18	Fasteners may not penetrate both pieces of sheet metal, must allow for thermal expansion.
SM 23	Surface mounted counter flashing should be limited to non-permanent construction. Use thru wall or recessed counter flashing with lead wedge securement in permanent construction.
SM 3, 5-7, 27	Concealed sealant to be non-curing butyl.
SM 6	Not allowed.
SM-7	Not allowed.
SM-3	Not recommended for permanent construction.
SM-27	Not recommended for permanent construction.
SM-28	Not allowed.
SM-42	Minimum of two lines of non-curing butyl tape, three lines for permanent const.
SM-35	Not allowed.
SM-36	Not allowed.
SM 36	Recommended but normally will include two end dams with UV resistant sealant.
SM-1	Not recommended: Lap seam, mechanically fastened seam, overlap standing seam.
A-Mtl	Do not reference NRCA details, use SMACNA.
S-Mtl	Do not reference NRCA details, use MBMA.

CHAPTER 4 ROOF SYSTEM RELATED SHEET METAL FLASHINGS

4-1 GENERAL.

Architectural sheet metal is integrated into both low- and steep-slope roof systems to assist those systems in achieving protection against moisture intrusion. Typical uses include copings, fascias, gutters, downspouts, and counter-flashings.

4-2 REFERENCE STANDARDS.

Use the latest edition of the NRCA Roofing Manual: Architectural Metal Flashing, Condensation Control, and Reroofing as the primary design guide reference. Additional design assistance can be found in SMACNA *Architectural Sheet Metal Manual*. Certain codes will require compliance with ANSI/SPRI ES1.

4-3 SHEET METAL.

4-3.1 Sheet Metal Type.

Use pre-finished aluminum, pre-finished galvanized steel, 55% AlZn (such as Galvalume), or stainless steel. On historic projects copper, terne coated copper or terne coated stainless steel may be required.

4-3.2 Sheet Metal Gauge and Thickness.

Sheet metal thickness is defined by either gauge or thickness depending on the material. Steel is defined by gauge such as 22 and 24 gauge. Aluminum is defined by thickness such as .040, .050 and .063. Stainless steel is defined by gauge such as 22 and 24 gauge and shall be a minimum of 304 alloy. The architectural sheet metal location on the roof, its width and vertical face will define the thickness or gauge required to prevent distortion. Use minimum 24 gauge pre-finished steel and .063 aluminum for large sheet metal components such as copings, fascias, expansion joint covers, gutters and counterflashings.

4-3.3 Organic Coatings.

When paint coatings are used for exterior applications they must be 1 mil (0.0254 mm) dry film thickness consisting of 0.25 mil (.00635 mm) prime coat and 0.75 mil (0.019 mm) finish coat minimum applied by the continuous coil coating method. Paint resin, with noted exceptions, must be 70% polyvinylidene fluoride (PVDF) containing 100% inorganic pigments. Many other resin types (including PVF) are available but shall only be considered for unusual environments or uses.

Paint coatings must be applied over metallic coatings for carbon steel. Organic coatings must be directly applied to aluminum material.

4-4 MATERIAL COMPATIBILITY.

Use sheet metal anchors that are compatible with the main material. Use stainless steel with pre-finished steel material and use aluminum or type 304 stainless steel with the pre-finished aluminum material. When exposed, fasteners shall incorporate a stainless steel washer with an EPDM washer below. Mill-finished or clear anodized aluminum shall not be used with alkali masonry mortar exposure.

Separate sheet metal components from contact with preservative pressure-treated wood to avoid the corrosive effects of the wood treatment. The following shall be used to attach sheet metal components to pressure-treated wood:

- Type 304 or type 316 stainless steel,
- Double hot dipped galvanized complying with ASTM A153/A153M
- Other specially treated corrosion-resistant fasteners complying with ASTM A653/A653M, Class G185

4-5 EXPANSION AND CONTRACTION.

Allow for the sheet metal expansion and contraction in both the main metal and continuous cleats per SMACNA. This can be accomplished with cleated joints such as drive cleats and predrilled pilot holes for fastener locations.

Wood blocking shall be designed and installed per FM 1-28 and sheet metal designed and installed per ANSI/SPRI ES-1.

This Page Intentionally Left Blank

CANCELLED

CHAPTER 5 STANDING SEAM METAL ROOFING SYSTEM DESIGN REQUIREMENTS

5-1 INTRODUCTION.

SSMR systems can be either hydrostatic that are designed and constructed to be totally water resistive (like a roof membrane) or hydrokinetic that are not totally resistive to water intrusion and rely on slope to shed water. Both hydrostatic and hydrokinetic systems are permitted per the requirements of MBMA and this chapter.

5-2 GENERAL REQUIREMENTS.

The following general requirements apply to all SSMR, regardless if they are hydrostatic or hydrokinetic.

SSMR systems may be installed over open structural framing, or over structural decks. They may be used for new roofing, roofing removal and replacement, and are notably effective for recover of aged metal roofs. They can also be used in low-slope to steep-roof conversions without tear-off. There are many metal roof types. This chapter addresses steel and aluminum materials. Materials and roof types other than described herein may only be used when approved by the appropriate Service Subject Matter Expert (SME). These include special site-formed projects, curved applications of profiles other than described herein, crafted metals (soft metals such as copper, terne, and zinc), and all face-fastened panel types. The roof geometry and layout shall be simplified to the degree possible for SSMR systems. Complicated geometries increase the potential for performance problems.

5-2.1 Design-Build.

Design-build contracts for metal roofing systems must name the specific type of metal roofing system desired (including rib type and watertight or water shedding detailing) and identify all critical performance requirements. It is not sufficient to simply require a metal roofing system per this UFC.

5-2.2 Panels Type.

Ultimately, the panel type decision is aesthetic, economic, and functional. It may also be dictated by wind uplift performance. The effects of oil canning are minimized by fluting, striation, pencil rib or other formations to disrupt the flat panel. However, formations such as these that result in an offset dimension greater than 0.125 in. (3 mm) in height are not allowed due to excessive voids created at panel termination points. When flat pan configurations are used (no disruptions in the flat), tension level coil must be specified to ensure flatness. Panel width must be between 12 and 24 in. (305 and 610 mm). A 16 in. (405 mm) panel type is widely available. Panels must be furnished in lengths of 60 ft. (18.3 m) or longer, when possible, to minimize or eliminate end-to-end joints (panel laps). Panels must be factory fabricated wherever possible.

Site forming can be considered when a roof panel exceeds the allowed length for shipping. Avoid end laps in metal roofs.

5-2.3 Overhangs.

The roof deck and the roof panels shall extend a minimum of 8 in. (200 mm) beyond the exterior wall, with 12 to 24 in. (305 to 610 mm) preferred.

5-2.4 Insulated Metal Panels.

Insulated metal panel roof systems must only be used without end lap joints and should be limited to maximum 25 foot (7.62 m) length of panel due to thermal expansion/1/

5-2.5 Corrosion Treatment.

The preferred protective coating for carbon steel is 55% (by weight) aluminum-zinc alloy (such as Galvalume) in application rate of .55 oz. minimum per ft.² (15.6 g minimum per 0.1 m²) for unpainted material (AZ55) and .50 oz. minimum per ft.² (14.2 g minimum per 0.1 m²) for pre-painted material (AZ50). When unpainted 55% AlZn (such as Galvalume) material is used it must have an additional protective coating of acrylic applied at a nominal thickness of 0.3 mil (.0076 mm).

In corrosive environments such as coastal areas, aluminum metal panels with PVDF coating is the preferred material. Steel with AZ55 with PVDF coating is also acceptable. Galvanized steel (G90) with or without a coating is not recommended unless the building is temporary. Coastal areas also require careful design of dissimilar metals. The underside of metal roof panels in coastal areas shall have a minimum 0.5 mil (.0127 mm) DFT factory applied primer.

Steel and aluminum shall not be in contact unless separated with a coating, sealant, or other impervious non-metallic or non-conductive material.

5-2.6 Organic Coatings.

When paint coatings are used for exterior applications they must be a minimum 1 mil (0.0254 mm) dry film thickness consisting of 0.2 mil (.0051 mm) prime coat and 0.8 mil (0.02 mm) finish coat minimum applied by the continuous coil coating method. Paint resin, with noted exceptions, must be 70% polyvinylidene fluoride containing 100% inorganic pigments. Exceptions include interior applications, soffit applications, and surfaces painted white. Many other resin types (including PVF) are available but shall only be considered for unusual environments or uses. Paint coatings must be applied over the corrosion treatment for carbon steel.

If aluminum is used it shall be pre-finished with a factory-applied polyvinylidene fluoride (PVDF) coating. Organic coatings must be directly applied to aluminum material.

5-2.7 Metal Thickness.

When aluminum substrates are used the minimum required thickness is .032 in. (.81 mm). When coated steel substrates are used, the minimum required thickness is 24 ga. (0.0239 in. (0.6071 mm)) not including metallic coating. The minimum thickness is 0.0209 in. (0.5309 mm.) Heavier gauges may be necessary to meet wind uplift criteria per Chapter 1 of this UFC. The specification mandate of heavier section thickness such as 0.040 in. (1 mm) for aluminum and 22 ga. (0.76 mm) for steel may improve the aesthetic with respect to oil canning.

The minimum panel material thickness must be consistent with the material thickness as it was tested for structural capacity in ASTM E1592 *Standard Test Method for Structural Performance of Sheet Metal Roof and Siding Systems by Uniform Static Air Pressure Difference*.

5-2.8 Panel Attachment.

Attach panels with concealed clips. Thermal expansion clips are to be of a two-piece design with a top portion that folds into the panel seam and a base that attaches to the structure with two screw fasteners. The joining of base to top components must anticipate the full range of thermal cycling of the panels, using panel temperature differential of 200 degrees Fahrenheit (93 degrees Celsius). In northern/cold climates, at elevations over 8000 ft. (2440 m), or when using dark roof colors use a panel temperature differential of 220 degrees Fahrenheit (104 degrees Celsius). Maximum frictional resistance between top and base components must not exceed 5 lbs. (2.25 kg) in the finished, folded seam. When eave-to-ridge in-plane dimensions are less than 25 ft. (7.6 m), fixed (one-piece) clips may be employed.

Concealed clips shall accommodate twice the anticipated maximum panel series expansion and contraction based on the temperature differentials noted above.

5-2.8.1 Fixed Point.

Panels must be rigidly fixed (pinned) to the building structure at a single point along their length and allowed to float at other attachment points in order to accommodate inherent thermal movement. Normally that point is at the panel's ridge or eave end. Such attachment must be designed to resist all in-plane service loads including snow and other environmental loads, thermal cycling and frictional resistance experienced at the clips, and the interface of the panel to the supporting structure or deck. Fixed clips shall be used in addition to the through panel fasteners to provide fixity.

5-2.8.2 Exposed Fasteners.

Minimize the use of fasteners that penetrate the weathering surface of the roof panels and flashings. Use these fasteners in panels only at end-to-end joining and at the lower termination point (point of fixity) of the panel. Fastening through the flat of the roof panel in the ridge or hip areas shall be concealed behind rib closures and under

flashings. Sealing washers shall be EPDM (not neoprene) to improve durability and service life. When fastening sheet-to-sheet, back-up plates are required to stiffen the joint and provide solid attachment for screws.

5-2.9 Flashings and Penetrations.

In the design phase, care needs to be taken to locate penetrations within the central portion of the panel and design flashings that will accommodate the anticipated climate. At all times the thermal movement characteristics and hydrostatic performance shall be preserved. Panels shall be free to cycle thermally independent of building structure. Curbs, flashings, and penetrations shall not restrict movement by pinning the panels to the structure. With limited exception, all connections of flashings, curbs, and penetrations must be hydrostatic in design to a minimum height of 6 in. (150 mm) above the drainage plane, above which they may be hydrokinetic. In some cases, especially where differential thermal movement occurs, consider using sheet membrane material, such as EPDM, for a hydrostatic connection. When doing so, the membrane shall be protected from exposure using a sheet metal shroud flashing.

Exceptions to these practices may be where a ridge is a venting design. In these cases, hydrostatic construction will be to the height of the panel rib seam (top of ridge closure). Such exceptions to hydrostatic construction should be scrutinized. Concealed sealants must be non-curing polyisobutylene tapes, supplemented with butyl tube grade when necessary to improve flow characteristics into crevices and other difficult areas. These compounds shall be sandwiched between joint components, in concealed locations, and not exposed. Curing compounds are not permitted. Exposed sealants are to be high-grade polyurethane.

5-2.9.1 Round Pipes, Flues, and Soil Stacks.

Flash small, round penetrations with pre-manufactured EPDM black rubber boots having a laminated aluminum compression ring at their base and secure at the top using a stainless steel draw band. Penetrations shall be coordinated to be in the center of the panels and the application of the pre-manufacturer flashing boot shall not interrupt a seam location. Large penetrations (wider than roof panel width minus 5 in. (mm)) require a fully detailed curb.

5-2.9.2 Roof-mounted HVAC Equipment Curb Flashing.

Large and heavy roof-mounted HVAC equipment is not recommended on metal roof systems. If the HVAC equipment is not to be at ground level, provide a platform with access within the roof system and that uses a single-ply roof system such as PVC (with good watertight details). For smaller hoods, ducts and fans, use minimum 0.080-in (2-mm) thick aluminum or 304 type stainless steel, welded prefabricated curbs for curb-mounted HVAC. The upslope curb flange must underlay roof panels and the down slope flanges must overlay the roof panels. The side curb flanges shall extend to the vertical seam on either side. Panel seams must terminate well before the curb wall and use built-in curb crickets to prevent ponding at curb wall.

5-2.9.3 Perimeter, Parapet, and other Miscellaneous Flashings.

Utilize the same factory finished material as roof panels for exposed flashings and shrouds. Provide slope for all parapet and coping caps and all horizontal projections of transitions.

5-2.10 Other Rooftop Appurtenances.

Minimize other roof accessories that penetrate the roof panels. When painted products are used, every effort shall be made to use the same sheet material as the roof, incorporating the same factory finish.

5-2.10.1 Snow Retention Devices.

In ASHRAE climate zones 4 and above, all metal roofs shall include continuous snow retention devices at all eaves that are non-corrosive, non-penetrating, and mechanically attached with convex setscrews to the standing seams and penetrations and roof curbs. Select snow retention devices to resist all in-service loads considering roof slope and design snow load. Prove adequacy on a site-specific basis by calculation and lab-tested holding strengths of devices. Snow retention devices that glue to panel surfaces or use attachments that penetrate roof panels are prohibited. Avoid using any device that voids material and coating warranties.

5-2.10.2 Lightning Protection.

Use aluminum lightning protection on metal roofs where appropriate. Install lightning protection system in accordance with the roof system warranty requirements (no penetration of roof panel at the valley or eave, limited or no penetrations elsewhere). If lightning protection is included on a roof that also includes snow retention devices, attach the lightning protection system to the snow retention devices.

5-2.10.3 Dormers and Mountings.

When possible, avoid interrupting roof planes with geometries that impede drainage, interrupt the drainage surface, or require valleys. Ensure positive drainage on the upslope side of dormers.

All mountings must be attached to the seams with non-penetrating seam clamps—avoiding breach of the weathering surface. Attach other appurtenances (lightning arrestors, condensate lines, conduits, roof walks, satellite dishes, etc.) with non-penetrating seam clamps. Avoid the use of dissimilar metals. Jacket any copper lines to isolate and prevent copper ion water runoff.

5-2.10.4 Fall Protection.

All roofs with a slope greater than 3:12 shall have permanently installed fall protection in accordance with Chapter 1. Select the fall-protection equipment metal and fasteners to minimize corrosion.

5-2.11 Wind Design.

5-2.11.1 In submittals provide a roof assembly which has been tested in accordance with ASTM E1592; and the roof manufacturer's technical staff will provide the necessary clip spacing based on the ASTM E1592 test results. The metal roof assembly shall replicate the ASTM E1592 tested assembly with respect to clip type, gauge, spacing, and attachment. Because the ASTM E1592 test is conducted with attachment to heavy gauge purlins, the actual construction assembly needs to match the pullout resistance of the tested assembly but may attach to a steel deck or other structural element. The ASTM E1592 tested assembly and the structural performance characteristics must be used when performing the ASCE 7 wind uplift calculations.

5-2.11.2 On **Army** and **Air Force** projects, the maximum clip spacing for metal roof assemblies shall be 60 in. (1525 mm) on-center in the field and 30 in. (760 mm) on-center in the perimeter and corner zones.

5-2.11.3 Install a minimum 16 ga (1.5 mm) bent steel plate at all eave, rake, and ridge edges of a metal roof assembly for roof attachment. Wood blocking (treated or untreated) shall not be used in metal roof assemblies.

5-3 HYDROSTATIC SYSTEM REQUIREMENTS.

5-3.1 General.

A hydrostatic system is a metal roof system in which the metal standing seam, laps at the eave and valley are constructed with positive attachment and non-curing sealant to provide a watertight assembly. Fixity will typically be at the eave and valleys in this roof system.

Use the MBMA Roofing Manual, latest edition, as the primary reference for design. This chapter limits the applicability of certain techniques permitted by the MBMA Roofing Manual. Where contents of the MBMA Roofing Manual are acceptable without modification, those sections are not mentioned herein.

5-3.2 Material.

Material must be either sheet aluminum or Galvalume coated sheet steel. Galvalume coated steel materials may be pre-finished, and in either case, substrate life will exceed paint life. Galvalume steel does not perform as well when in direct contact with salt spray. It is commonly used in coastal applications but will render a shorter service life. In some of the environments, aluminum may be the better choice, albeit at increased cost, greater thermal expansion and lesser availability. Contact of either metals with strong acids and alkalis shall be avoided. Avoid the use of dissimilar metals. Jacket any copper lines to isolate and prevent copper ion water runoff.

5-3.3 Panel Type.

Use a flat pan (pencil ribs and/or striations are recommended) standing seam profile with minimum finished seam height of 2.0 in. (50.8 mm), with a double fold (180 degree) seam or single fold (90 degree), bulb rib or trapezoidal rib. In general, greater seam heights lead to greater beam bending strength. This increases the wind resistance of the panel and reduces the potential to leak in ice damming situations.

5-3.3.1 Seam Configuration.

5-3.3.1.1 Panel edges must be of male and female interlocking design with integral sealant and machine folded (mechanically seamed) finishing of the seam. There can be no gap between any surface of interlocking male and female seam portions. Finished seam configuration may be either 90-degree, single fold (resembling an inverted “L”) with horizontal dimension of 0.62 in. (16 mm) minimum, or a 180-degree, double fold.

5-3.3.1.2 There are a variety of hydrostatic roof panel seam profiles. Metal roofs are most often 90-degree mechanically seamed, single-lock, vertical rib. The trapezoidal seam profile is also common and provides a raised standing seam elevated out of the water plane by a series of offsets, which also allow for cross seam (roof) expansion and contraction. The trapezoidal seam has an industrial appearance and requires end plugs to seal the profile at the end of the panel at eaves, penetrations, and valleys, which can be problematic. Trapezoidal rib panels shall only be used on roofs with minimal/no curbs and minimal/no valleys.

5-3.3.1.3 The raised mechanically seamed panel seam is made possible due to the profiles of the panel, which allow it to span between purlins. The vertical rib profile is seamed by a mechanical fold and either single or double locked depending on wind uplift requirements and desired aesthetics. A modification on this seam type is the mechanically seamed T rib.

5-3.3.1.4 The bulb seam is a raised standing seam that uses a bulbous top profile to provide seam strength. A differing look, the seam can easily be rendered watertight and can provide a unique seam profile.

5-3.3.1.5 Illustrations of a variety of hydrostatic roof panel seam profiles can be found in Appendix B.

5-3.3.2 **Panel Attachment.** Clips must be “wetted” to the male seam component with butyl sealant as necessary to ensure complete hydrostatic performance of the joint and as required by ASTM E2140.

5-3.3.3 **Seam Sealant.** Each seam must have a pre-applied bead of non-curing, non-hardening polyisobutylene-isoprene copolymer or terpolymer (butyl) to ensure complete hydrostatic performance. Sealant may be a hot melt butyl formulation if applied at the point of panel manufacture. Gas entrainment of sealant is permitted. The roll-forming machine must apply sealant. Continuity of seal with field applications

through all panel termination points is critical. Silicone sealant is not allowed. Primary seals must always be concealed within a joint. When secondary seals are used, they may be exposed one-part polyurethane.

5-3.4 Slope.

The minimum allowable slope for hydrostatic roofs is 1:12.

5-3.5 ASTM Test Method.

Hydrostatic joint performance shall be tested per ASTM E2140, *Standard Test Method for Water Penetration of Metal Roof Panel Systems by Static Water Pressure Head*. The test normally tests only the panel side and end-joints, but it can be adapted to test other assemblies also. In addition to the standard standing seam testing, test the eave of the metal roof system.

5-3.6 Hydrostatic Specifications.

Use the UFGS instead of the specifications shown in the MBMA Roofing Manual.

5-3.7 Recommended Hydrostatic Construction Details.

Regardless of actual project slope, use the “Vertical Rib Low-slope Details” (2-1 through 2-30) in the MBMA Roofing Manual, as applicable, as the basis for the design and detailing principals. Do not use NRCA or SMACNA details for hydrostatic metal roofing.

5-4 HYDROKINETIC SYSTEM REQUIREMENTS.

5-4.1 General.

A hydrokinetic system is a metal roof system in which the metal standing seam, eaves, and valleys accommodate expansion and are constructed in a way that allows some water infiltration. The infiltrating water is drained through weeps in the roof assembly and with a watertight underlayment membrane under the roof. The fixity will typically be at the ridge in this roof system.

Use the NRCA Manual: Metal Panel and SPF Roof Systems – 2008, NRCA Manual: Architectural Metal Flashing and the SMACNA Architectural Sheet Metal Manual to guide the design of the roof system and details.

5-4.1.5 General Hydrokinetic Roof System Requirements

5-4.1.5.1 Hydrokinetic metal roof panels require support and need to be installed over a roof deck. Insulation can be installed over the roof deck if desired. The hold-down clips shall be secured to the roof deck for wind uplift resistance.

5-4.1.5.2 The seams and laps of a hydrokinetic metal roof system are not watertight themselves, so a watertight continuous high-temperature self-adhering underlayment

shall be provided under the entire roof. Designer will evaluate the required vapor permanence of the underlayment. In ASHRAE climate zones 3 and above, high-temperature self-adhering ice dam protection shall be installed to the substrate to a height of 36 in. (915 mm) minimum above the interior face of the exterior wall. In these zones, the underlayment can be laid over the self-adhering ice dam protection.

5-4.1.5.3 Roof panels with lengths less than 50 ft. (15.2 m) shall be fixed at the ridge with the expansion being accommodated at the eaves and valleys.

5-4.1.5.4 Rosin paper is not allowed as a separation sheet.

5-4.1.5.5 When roof panels run parallel to masonry sidewalls, the through-wall flashing shall incorporate a counter-flashing receiver and the transitional flashing incorporated into the stepped counter-flashing receiver. The counter-flashing receiver shall be integral with the through-wall flashing.

5-4.2 Material.

Material must be either sheet pre-finished aluminum or pre-finished steel. In some of the environments, aluminum may be the better choice. Contact of either metals with strong acids and alkalis shall be avoided. Avoid the use of dissimilar metals. Jacket any copper lines to isolate and prevent copper ion water runoff.

On historic projects raw copper, pre-patinized copper, zinc coated copper or terne coated stainless steel may be appropriate to match the existing historical context.

5-4.3 Panel Type.

Panels are typically flat with upturned ribs of 1.5 in. (40 mm) minimum. For Military projects, use panel widths from 12 to 18 in. (305 to 455 mm).

5-4.3.1 Seam Configuration.

Panel edges may be either male or female interlocking design or vertical matching legs designed to be covered with a separate seam cover cap installed over the vertical legs. Wood batten strips are only allowed on historic projects.

Illustrations of a variety of hydrokinetic roof panel seam profiles can be found in Appendix B.

5-4.3.2 Seam Sealant.

Factory applied sealant within the standing seams is recommended.

5-4.4 Flashing Details.

All flashings at vertical surfaces shall be integrated and coordinated with the through-wall flashing to assure water tightness and drainage. A water resistant membrane shall

be incorporated into the flashing detail to prevent moisture intrusion from wind driven rain and water from ice damming.

5-4.5 Slope.

The minimum slope for hydrokinetic roofs is 4:12. In ASHRAE Climates Zones 4 and above, which have the potential for ice damming, use a minimum slope of 6:12.

5-4.6 Hydrokinetic Roofing Specifications.

Use the UFGS instead of the specifications shown in the NRCA Manual.

5-4.7 Recommended Hydrokinetic Construction Details.

Use the NRCA Construction Details CD - 2010 listed in and as modified by Table 5-1 in this UFC. SMACNA Manual details may also be used. Use these details as the basis for design and detailing principals.

CANCELLED

TABLE 5-1. HYDROKINETIC METAL ROOFING CONSTRUCTION DETAIL LIMITATIONS	
NRCA Detail	Additional Requirements
AM-1	Must have self-adhesive underlayment or sealant between underlayment and flashing
AM-1A	
AM-2	
AM-3	
AM-3A	
AM-4	Must have fixity provided at the ridge(a structural attachment at ridge closure fasteners)
AM-5	Must have fixity provided at the ridge(a structural attachment at ridge closure fasteners)
AM-6	Vertical joints will be sealed and fixity will be provided at hip
AM-7	
AM-7A	Only if skilled sheetmetal workmanship to be provided
AM-8	Must have fixity at head wall
AM-8A	Must have fixity at head wall
AM-10	
AM-11	
AM-12	
AM-13	With rain collar
Curb Detail to be in standard drawings – NRCA's are not acceptable	
AM-16	
AM-17	
AM-17A	
AM-18	

This Page Intentionally Left Blank

CANCELLED

CHAPTER 6 RE-ROOFING REQUIREMENTS

6-1 OVERVIEW.

Eventually every roofing system will reach the end of its economic life. Reroofing options are presented under Terminology below.

6-2 GENERAL CONSIDERATIONS.

The NRCA Manual provides typically allowable re-roofs over existing roofing. See below for other considerations.

6-2.1 Terminology.

For the purposes of this UFC, use the following terminology to describe the re-roofing options:

- **Roof Replacement:** The removal of the existing roof system down to the roof deck and the installation of a new roof system.
- **Roof Recover:** The installation of a new roof system over an existing roof system. Table 6-1 notes the roof systems allowable for recover.
- **Metal Roofing Retrofit:** The process of installing a new metal roof system over an existing metal roof system.
- **Metal Roofing Overbuild:** The installation of a new metal roof system, including structural framing system over a low-slope roof system.

6-2.2 Life Cycle Cost Analysis.

It is unlikely that a recover will last as long as a total tear-off and replacement. Therefore, carefully weigh the life-cycle cost of recover versus replacement. See Appendix B for information on how to conduct a Life Cycle Cost Analysis. The cost of replacement is greatly affected by ease of access, the need for slope buildup, and the need to raise mechanical equipment for access. Reroofing is an excellent time to remove obsolete equipment and stacks from the roof.

6-2.3 Low-sloped Versus Steep-Sloped Considerations.

The low-slope and steep-sloped roof present different challenges in reroofing. An attic space, typically found in steep-slope roof construction, provides separation of construction activities from the interior of the building. However, on steeper slope roofs, scaffolding and protected access to the building may be major construction cost items.

TABLE 6-1. ALLOWABLE RECOVER OVER EXISTING ROOFING*

Existing Roofing	New Overlay Roofing Material								
	Built-up	Shake	Asphalt Shingle	Tile Roof	Metal Roof	Mod Bit	SPF	MREC ²	Single-ply
Slate	No	No	No	No	No	No	No	No	No
Built-Up	Yes	No	No	No	Yes (w/ framing)	Yes	Yes	Yes	Yes
Asphalt Shingle ¹	No	No	Yes	Yes (2.5:12)	Yes	No	No	Yes	No
Asphalt Shingle over Wood	No	No	No	No	No	No	No	Yes	No
Asphalt Shingle (AS) over AS	No	No	No	No	No	No	No	No	No
Tile Roof	No	No	No	No	No	No	No	No	No
Metal Roof	No	No	No	No	Yes	No	Yes	Yes	Yes
Modified Bitumen	Yes	No	No	No	Yes (w/ framing)	Yes	Yes	Yes	Yes
Single-ply	No	No	No	No	No	No	No	No	No

* See Chapter 3 for Military limitations on roofing types.

(X:X) = (Minimum Roof Slope)

¹ See specific requirements

² Mesh reinforced elastomeric coatings.

\1\

6-3 MESH REINFORCED ELASTOMERIC ROOF COATINGS (MREC).

6-3.1 Mesh reinforced elastomeric roof coatings can be used in two general ways:

- Mesh Reinforced Elastomeric Roof Coating (MREC): The application of a liquid applied elastomeric coating to an existing roof in order to sustain the roof at low cost.
- Mesh Reinforced Elastomeric Roof: The application of a liquid applied elastomeric coating to an existing substrate such as concrete or mechanically fastened overlayment.

For either application, the minimum dry film thickness is 40 mils (1 mm) applied in stages over 100% polyester fabric reinforcing.

6-3.2 MREC has a wide range of use in reroofing, repair, and sustainment. As indicated in Table 6-1, MREC may be used over most roof systems such as built up, metal, and modified bitumen. These coatings provide not only waterproofing, but can

achieve cool roof ratings as well. At a fraction of the cost of replacing, MREC offers a high return on investment with low risk.

/1/

6-3.3 Elastomeric coatings may provide an inexpensive alternative to metal roof removal and replacement.

6-4 LOW-SLOPE ROOFING REMOVAL AND REPLACEMENT.

6-4.1 Analysis of Existing System.

Replacement of an existing roof requires a detailed analysis of the existing roof deck, roof insulation and the roof structure. This analysis shall include a test cut of the existing roof system to determine the composition of the existing roofing system, a non-destructive moisture testing, core sampling, and a review of the structure by a licensed structural engineer.

Examine the clearances between the anticipated re-covered roof plane and any above-roof horizontal ductwork, mechanical units, and wall flashings. Based on the required clearances, determine if they will need to be raised. \1\ If this would result in significant cost or disruption of operations, consider MREC to prolong life until equipment can be raised. /1/See NRCA Manual for additional information.

6-4.2 Phenolic Foam Board Insulation.

When this material is found in existing installations with steel roof decks, it must be replaced as part of the project and an in-depth evaluation of the steel deck condition conducted to determine if replacement is required. Even if replacement is not required, the steel roof deck shall be painted prior to the installation of the new roof system. Following are approved paints:

- (IL) Rust-Oleum High Performance Epoxy 9100 System Coating, manufactured by Rust-Oleum, 11 Hawthorn Parkway, Vernon Hills, IL; (708) 367-7700.
- Rust-Inhibitive Steel Deck Coating: DTM Acrylic Primer/Finish manufactured by Sherwin Williams, 161 Greenwood Drive, Bridgeville, PA; (412) 247-2228.
- Amerlock 400 High Solids Epoxy Coating, mixed with equal amount Amerlock resin; manufactured by Ameron Protective Coatings, 201 N. Berry Street, Brea, CA 92622; (714) 529-1951.
- ZRC Cold Galvanizing Compound; manufactured by ZRC Products Company; 21 N. Newport Avenue, Quincy, MA; (617) 328-6700.

6-4.3 Testing for Asbestos Containing Materials (ACM).

If testing of the existing roof system to be removed uncovers the presence of ACM, this fact shall be communicated to the roofing contractor in the contract documents so that the appropriate removal and disposal efforts can be determined by the contractor and included in their costs.

6-4.4 Slope.

In existing construction, every effort must be made to achieve the ½:12 slope required for new construction. However, where ½:12 slopes cannot be achieved, ¼:12 may be used with specific approval by the following authorities:

- Army. District-level Authority Having Jurisdiction
- Navy. Project Manager
- Air Force. Project manager

When increasing slopes of existing roof decks, clearances for rooftop structures such as curbs, base flashings, access doorsills, etc. must be increased to the minimums recommended in the NRCA Manual. Comply with the following:

- Four-way tapered insulation is the most effective method to drain a roof, followed by two-way tapered with saddles. The width of the saddles is critical to move water to the drains.
- Saddles and crickets to the high side of curbs shall be a minimum of twice the roof slope.
- Consult with a plumbing engineer to determine the appropriate number of roof drains and the size of drainpipe.
- See Metal Roofing Overbuild below for additional slope issues.

6-5 REPLACING SINGLE-PLY SYSTEMS.

Single-ply systems shall not be recovered but shall be replaced in full. If the existing membrane is not removed, it may drag and distort the new membrane. The removed membranes shall be recycled.

6-6 LOW-SLOPE CONVERSIONS.

In poorly draining low-slope roofs where the use of tapered insulation cannot improve drainage, the roof may be a candidate for conversion to a steep-slope system. Refer to CERL Technical Report M85/05 *Steep Roof Conversions*. Slope conversions are often more expensive than in-kind reroofing, but may offer the opportunity to convert to a system that requires less maintenance.

6-7 TAPERED ROOF INSULATION SYSTEMS.

Tapered rigid board insulation shall be used when the existing facility has inadequate slope, and other means of providing adequate slope are more expensive over the lifecycle of the facility. Tapered rigid board roof insulation systems are more expensive per square unit than non-tapered insulation. Do not use wet fill to accomplish slope in existing systems. Use tapered rigid board in crickets and saddles to ensure positive drainage.

6-8 RECOVERING STEEP-SLOPE ROOFS.

Re-covering steep roofing such as asphalt shingles is easily done, provided that shingles being overlaid are in acceptable condition and the shingle being installed is of the same size. Building codes permit either one or two direct recovers with missing shingles replaced first and curled shingles flattened. No more than one layer of re-cover roofing may be specified on Military buildings. In recover, new metal flashing is required. Do not re-cover over wet or deteriorated materials. See Table 6-1.

Generally, underlayment is not required in shingle re-covers. Wood shakes and shingles are not a suitable substrate for new shingle or shake recover and must be removed.

6-8.1 Historic Buildings.

Existing roof system shall be replaced in kind, if possible.

6-9 METAL ROOFING.

6-9.1 Metal Roofing Recover.

When tearing off and replacing a failed hydrostatic SSMR system that is attached to a structurally sound roof substructure, one option is to use a standing seam metal roof and retrofit sub-purlin framing system. A structural evaluation of the framing system and the attached roof panels is required. The sub-purlins are custom fabricated with slot depth and spacing to nest over the existing metal roof profile and provide a level surface on which to attach the new metal roof panels.

6-9.2 Metal Roofing Overbuild.

Metal roofing is frequently selected for steep roof conversion since new lightweight structural members easily accommodate increased slope requirement, and the new metal roof may not need a new deck. The fire hazard concern about the newly created attic space must be addressed (FM Global Data Sheet 1-31). Ventilation concerns must also be addressed. Provide a watertight seal at penetrations of new framing connections through the old roof and maintain adequate drainage of the old roof during construction. In hurricane-prone areas, the original roof watertightness shall be maintained. The existing drainage system shall be disconnected and overflows provided at the roof surface level.

Also comply with the following:

- The new truss system shall be installed to the existing structure. This will require cutting the roof and removing in the attachment areas. Therefore, the old roof assembly will not be considered a complete vapor barrier, vapor retarder, air barrier, or insulation layer.
- All wet insulation shall be removed.
- The new attic space shall comply with all code and UFC requirements and may require a separate sprinkler system. The new attic space needs to be detailed to either be a venting attic space or semi-conditioned attic space.
- Although some slope build up systems have a structural system of trusses and purlins, a roof assembly using a metal deck is recommended. If trusses and purlins are used, the trusses shall be no more than 36 in. (915 mm) apart (even if this exceeds the ASCE 7 wind uplift requirements). The spacing of trusses will not exceed 60 in. (1525 mm) on center (oc). The cross members will be spaced in accordance with the clip spacing determined to meet the wind uplift forces and will not exceed 60 in. (1525 mm) oc. If the cross members are steel hat channels on a spacing of 48 in. (1220 mm) oc or greater, they will be 20 gage and a minimum of 1.5 in. (37 mm) in height.
- New slope build up metal roofs will have a minimum of 2 in. (50 mm) fiberglass batt insulation and continuous sealed vapor barrier installed directly underneath the roof panels to prevent corrosion from condensation.
- In ASHRAE climates zones 4 and up, it is strongly recommended that the assembly provided include an insulation layer and vented attic. \1\ Use of cool roofs in these climate zones can result in condensation and deterioration of the roof system, see Appendix B Best Practices Chapter 8. /1/
- The new roof system will provide overhangs over the existing building unless infeasible.
- It is strongly recommended that an RRC or a registered PE or RA that derives his or her principal income from roofing design be used in the design and shop drawing review.

6-10 SPRAY APPLIED POLYURETHANE FOAM.

Spray Applied Polyurethane Foam (SPF) roof systems may be considered as a repair option. It is particularly useful for repairing leaking metal roof systems and there is a desire to insulate or add insulation to the existing metal roofed building. SPF is also suitable for curvilinear shapes that do not permit the use of other approved roof systems.

SPF roof integrity is highly dependent on the proper mechanical field mixing of components, weather conditions at time of application, the foam's surface texture, and full coverage of the foam with the waterproofing coating materials. Manufacturer involvement during the application is encouraged and final inspection by the manufacturer is required prior to Government acceptance.

6-10.1 Foam.

Trained and certified applicators are required for installation because the foam is difficult to apply in uniform thickness and is highly sensitive to moisture, UV radiation, and wind velocities in excess of 12 miles/hr (19 km/hr). Even brief exposure to UV radiation in sunlight significantly degrades the foam. Degradation is progressive and will eventually result in system failure.

6-10.2 Coating.

Coatings are required for all SPF roof systems and ceramic granules shall be broadcast into the coatings installed over SPF. The coating protects the foam from UV degradation and must be applied to the foam as soon as possible after the foam has cured, but not more than 72 hours after foam installation. The granules provide protection against birds "pecking" the foam, provide better tracking on the coating when wet, and improve UV protection.

The base coating shall be a distinctly different color to provide an indication of the need for re-coating the roof system. The cost of replacing coatings is a significant component of the life cycle cost of SPF roof systems.

6-11 NEW TRUSSES AND DECKING.

Adding lightweight steel or wood trusses or rafters and a nailable deck permits the use of most conventional steep roofing systems.

6-12 SECONDARY PROTECTION.

Re-roofing invariably means disruption of building operations. For some sensitive occupancies (e.g., top floor computer rooms, surgical suites, laboratories, or telephone equipment) a total tear-off may be an unacceptable risk. The addition of a secondary membrane should be analyzed for condensation considerations.

6-13 CLIMATE/WEATHER CONSIDERATIONS.

A complete tear-off requires good weather since the building is usually occupied and nightly tie-offs may not provide adequate protection. The demands of protecting the building may prompt the use of a temporary roof—especially when a thicker insulation system is being added and it is not feasible to run from eave to ridge in a single day.

6-13.1 Night Seals.

At the end of each work period on a re-roofing project, the existing and new roof system shall be completely sealed from moisture intrusion and able to withstand a head of water. Existing drains must remain in working order until the new roof and associated drainage system is completely functional.

6-13.2 Upgrading Insulation.

Adding new insulation and/or an air space above the existing roof will change snow-melting characteristics. Generally, the added insulation reduces vapor condensation problems; however, the effect of the new insulation on vapor condensation must be determined.

6-14 LOGISTICAL CONSIDERATIONS.

Planning a re-roofing project must include all the logistics of the project, especially if the re-roofing occurs over an occupied building. Items to consider in the planning include the following:

- Protecting the newly applied roof covering from tear-off debris and construction traffic. This is critical to the longevity of the new roof;
- Planning for the possible presence of asbestos-bearing materials and landfill or recycling rules and regulations that may require separation of construction materials;
- Staging of new materials when existing materials are being torn off;
- Providing for material removal when dust management is used;
- Removing surface dirt and loose aggregate on aggregate-surfaced roofs prior to tear-off;
- Providing protection of building interior and protection of exterior finishes to remain;
- Providing interior dust control;
- Evaluating potential impact of new work on deck underside fireproofing; and
- Identifying and controlling fire risk from roof installation—especially torch-applied systems.

6-14.2 System and Site Safety Considerations.

Safety is of paramount importance. Protect occupants from fumes by coordinating the shutdown of air handling units. Protect occupants in areas where roofing work is taking place directly overhead by directly cordoning off the area, especially if deck repairs are taking place. Protect all occupants entering or leaving the building from falling materials. Exercise extreme care when reroofing over existing gypsum or wet fill deck systems. Identify the location of underground tanks and other sensitive, sub-surface items so that heavy vehicles do not overload these areas.

6-14.3 Deck Replacement.

If deck replacement is necessary, the operations directly beneath the deck being replaced will require shut down for safety and leakage reasons. Additionally, since it may be impossible to maintain HVAC services, humidity control, and air exchange with the building roof being open, a more extensive shutdown may be required.

CANCELLED

This Page Intentionally Left Blank

CANCELLED

APPENDIX A REFERENCES

Also see Appendix F for additional reading.

- Architectural Sheet Metal Manual*, Sheet Metal and Air Conditioning Contractors National Association (SMACNA), 4201 Lafayette Center Drive, Chantilly, VA, 22021, www.smacna.org/
- ASCE 7-02, *Minimum Design Loads for Buildings and other Structures*, latest edition, American Society of Civil Engineers (ASCE) 1801 Alexander Bell Drive, Reston, VA, 20191-4400, www.asce.org/
- ASHRAE Standard 90.1, *Energy Standards for Buildings Except Low-Rise Residential*, American Society of Heating, Refrigerating and Air-Conditioning Engineers, Inc., (ASHRAE), 1791 Tulle Circle, NE, Atlanta, GA, 30329, www.ashrae.org/
- ASHRAE Standard 90.2, *Energy-Efficient Design of Low-Rise Residential Buildings*, American Society of Heating, Refrigerating and Air-Conditioning Engineers, Inc., (ASHRAE), 1791 Tulle Circle, NE, Atlanta, GA, 30329, www.ashrae.org/
- ASHRAE Handbook – Fundamentals, American Society of Heating, Refrigerating and Air-Conditioning Engineers, Inc, (ASHRAE), 1791 Tulle Circle, NE, Atlanta, GA, 30329, www.ashrae.org/
- ANSI/ASSE Z359, *Fall Protection Code*, American National Standard Institute/American Society of Safety Engineers, 1800 East Oakton Street, Des Plaines, Illinois, 60018, www.asse.org
- ANSI/ASSE A1264.1, *Safety Requirements for Workplace Walking/Working Surfaces and Their Access; Workplace Floor, Wall and Roof Openings; Stairs and Guardrails Systems*, American National Standard Institute/American Society of Safety Engineers, 1800 East Oakton Street, Des Plaines, Illinois, 60018, www.asse.org
- ANSI/SPRI ES1, *American National Standard for Edge Systems Used with Low-slope Roof Systems*, Single Ply Roofing Industry (SPRI), 411 Waverley Oaks Road, Suite 331, Waltham, MA 02452, www.spri.org
- ANSI/SPRI RP-4, *Wind Design Standard For Ballasted Single-ply Roofing Systems*, SPRI, 411 Waverley Oaks Road, Suite 331, Waltham, MA 02452, www.spri.org
- ASTM A153/A153M, *Standard Specification for Zinc Coating (Hot Dip) on Iron and Steel Hardware*, American Society for Testing and Materials (ASTM), 100 Barr Harbor Drive, West Conshohocken, PA, 19428-2959, www.astm.org/
- ASTM A653/A653M, *Standard Specification for Steel Sheet, Zinc Coated (Galvanized) or Zinc-Iron Alloy Coated (Galvannealed) by the Hot Dip Process*, American Society

for Testing and Materials (ASTM), 100 Barr Harbor Drive, West Conshohocken, PA, 19428-2959, www.astm.org/

ASTM C406/C406M, *Standard Specification for Roofing Slate*, American Society for Testing and Materials (ASTM), 100 Barr Harbor Drive, West Conshohocken, PA, 19428-2959, www.astm.org/

ASTM C1289, *Standard Specification for Faced Rigid Cellular Polyisocyanurate Thermal Insulation Board*, ASTM, 100 Barr Harbor Drive, West Conshohocken, PA, 19428-2959, www.astm.org/

ASTM D226/D226M, *Standard Specification for Asphalt-Saturated Organic Felt Used in Roofing and Waterproofing*, ASTM, 100 Barr Harbor Drive, West Conshohocken, PA, 19428-2959, www.astm.org/

ASTM D448, *Standard Classification for Sizes of Aggregate for Road and Bridge Construction*, ASTM, 100 Barr Harbor Drive, West Conshohocken, PA, 19428-2959, www.astm.org/

ASTM D1863, *Standard Specification for Mineral Aggregate Used on Built-Up Roofs*, ASTM, 100 Barr Harbor Drive, West Conshohocken, PA, 19428-2959, www.astm.org/

ASTM D3746, *Standard Test Method for Impact Resistance of Bituminous Roofing Systems*, ASTM, 100 Barr Harbor Drive, West Conshohocken, PA, 19428-2959, www.astm.org/

ASTM D4263, *Standard Test Method for Indicating Moisture in Concrete by the Plastic Sheet Method*, ASTM, 100 Barr Harbor Drive, West Conshohocken, PA, 19428-2959, www.astm.org/

ASTM D4272, *Standard Test Method for Total Energy Impact of Plastic Films By Dart Drop*, ASTM, 100 Barr Harbor Drive, West Conshohocken, PA, 19428-2959, www.astm.org/

ASTM D4869/D4869M, *Standard Specification for Asphalt-Saturated Organic Felt Underlayment Used in Steep-slope Roofing*, ASTM, 100 Barr Harbor Drive, West Conshohocken, PA, 19428-2959, www.astm.org/

ASTM D5957-96, *Standard Guide for Flood Testing Horizontal Waterproofing Installations*, ASTM, 100 Barr Harbor Drive, West Conshohocken, PA, 19428-2959, www.astm.org/

ASTM E96/E96M, *Standard Test Method for Water Vapor Transmission of Materials*, ASTM, 100 Barr Harbor Drive, West Conshohocken, PA, 19428-2959, www.astm.org/

ASTM E1592, *Standard Test Method for Structural Performance of Sheet Metal Roof and Siding Systems by Uniform Static Air Pressure Difference*, ASTM, 100 Barr Harbor Drive, West Conshohocken, PA, 19428-2959, www.astm.org/

ASTM E2140, *Standard Test Method for Water Penetration of Metal Roof Panel Systems by Static Water Pressure Head*, ASTM, 100 Barr Harbor Drive, West Conshohocken, PA, 19428-2959, www.astm.org/

ASTM F1869, *Standard Test Method for Measuring Moisture Vapor Emission Rate of Concrete Subfloor Using Anhydrous Calcium Chloride*, ASTM 100, Barr Harbor Drive, West Conshohocken, PA, 19428-2959, www.astm.org/

Building Design Elements for Enhanced Fall Protection for Construction and Maintenance Personnel: An NRCA Perspective, National Roofing Contractors Association (NRCA), 10255 West Higgins Road, Suite 600, Rosemont, IL, 60018-5607, www.nrca.net

CERL Report M85/05, *Sloped Roof Conversions for Small, Flat-Roofed Buildings*, (1985), Construction Engineering Research Laboratory (CERL), 5285 Port Royal Road, Springfield, VA, 22161 (order from NTIS: www.dtic.mil)

CRREL Report MP-01-5663, *Minimizing the Adverse Effects of Snow and Ice on Roofs*, Cold Regions Research and Engineering Laboratory (CRREL), 72 Lyme Road, Hanover, NH, 03755, www.crrel.usace.army.mil/library/technicalpublications.html

CRREL MP 5106, *Attic Ventilation Guidelines to Minimize Icings at Eaves*, Cold Regions Research and Engineering Laboratory (CRREL), 72 Lyme Road, Hanover, NH, 03755, www.crrel.usace.army.mil/library/technicalpublications.html

CRREL MP 5420, *Ventilating Cathedral Ceilings to Prevent Problematic Icings at their Eaves*, Cold Regions Research and Engineering Laboratory (CRREL), 72 Lyme Road, Hanover, NH, 03755, www.crrel.usace.army.mil/library/technicalpublications.html \2\

Department of the Navy, *Fall Protection Guide*, US Department of the Navy, http://www.public.navy.mil/navsafecen/Documents/OSH/FP/FALL_PROTECTION_GUIDE_MAY_15.pdf /2/

FM Global Property Loss Prevention Data Sheets, Factory Mutual Global (FM), 1301 Atwood Avenue, P.O. Box 7500, Johnston, RI, 02919, www.fmglobal.com/

FM 4470, *Approval Standard for Single-Ply, Polymer-Modified Bitumen Sheet, Built-Up Roof (BUR) and Liquid Applied Roof Assemblies for Use in Class 1 and Noncombustible Roof Deck Construction*, Factory Mutual Global (FM), 1301 Atwood Avenue, P.O. Box 7500, Johnston, RI, 02919, www.fmglobal.com/

International Building Code, International Code Council, 500 New Jersey Avenue, NW, 6th Floor, Washington, DC 20001, www.iccsafe.org

Materials Selection Guide for Army Installations Exposed to Severely Corrosive Environments, Construction Engineering Research Laboratory, J.R. Myers, Ashok Kumar, and L.D. Stephenson, March 2002, 5285 Port Royal Road, Springfield, VA, 22161 (order from NTIS: www.dtic.mil)

MBMA Roofing Manual, *Metal Roofing Systems Design Manual*, Metal Building Manufacturers Association (MBMA), 1300 Sumner Avenue, Cleveland, OH, 44115-2851, www.mbma.com

NRCA Building Design Elements for Enhanced Fall Protection for Construction and Maintenance Personnel: An NRCA Perspective, National Roofing Contractors Association (NRCA), 10255 West Higgins Road, Suite 600, Rosemont, IL, 60018-5607, www.nrca.net

NRCA Building Owners Guide to Roof-mounted Photo Voltaic Systems, National Roofing Contractors Association (NRCA), 10255 West Higgins Road, Suite 600, Rosemont, IL, 60018-5607, www.nrca.net

NRCA Guidelines for Roof-mounted Photovoltaic Systems, National Roofing Contractors Association (NRCA), 10255 West Higgins Road, Suite 600, Rosemont, IL, 60018-5607, www.nrca.net

NRCA Roofing Manual, *Comprised of Five Manuals*, National Roofing Contractors Association (NRCA), 10255 West Higgins Road, Suite 600, Rosemont, IL, 60018-5607, www.nrca.net

NRCA Vegetative Roof Systems, National Roofing Contractors Association (NRCA), 10255 West Higgins Road, Suite 600, Rosemont, IL, 60018-5607, www.nrca.net

Slate Roofs: Design and Installation Manual, National Slate Association, P.O. Box 172, Poultney, VT 05764, slateassociation.org/

SMACNA Architectural Sheet Metal Manual; Sheet Metal and Air Conditioning Contractors' National Association, 4201 Lafayette Center Drive Chantilly, Virginia 20151-1219, www.smacna.org/

UFC 1-200-01, *DoD Building Code (General Building Requirements)*, Unified Facilities Criteria Program, dod.wbdg.org

\\1\UFC 1-200-02 *High Performance and Sustainable Building Requirements*, dod.wbdg.org /1/

UFC 3-101-01, *Architecture*, Unified Facilities Criteria Program, dod.wbdg.org

UFC 3-400-02, *Design: Engineering Weather Data*, Unified Facilities Criteria Program, dod.wbdg.org

UFC 4-010-01, *DoD Minimum Antiterrorism Standards for Buildings*, Unified Facilities Criteria Program, dod.wbdg.org

UL 2218/ASTM 2218, *Impact Resistance of Prepared Roof Covering Materials/Standard Test Method for Determining Forming Limit Curves*, 2600 NW Lake Road, Camas, WA 98607-8542, www.ul.com

Unified Facilities Guide Specifications (UFGS):
dod.wbdg.org

UFGS 01 62 35 *Recycled/Recovered Materials*

UFGS 07 22 00, *Roof and Deck Insulation*

UFGS 07 31 13, *Asphalt Shingles*

UFGS 07 31 26, *Slate Roofing*

UFGS 07 32 13, *Roof Tiles*

UFGS 07 32 14, *Clay Tile Roofing Replacement or Repair*

UFGS 07 41 13, *Metal Roof Panels*

UFGS 07 41 63, *Fabricated Roof Panel Assemblies*

UFGS 07 42 13, *Metal Wall Panels*

UFGS 07 51 13, *Built-Up Asphalt Roofing*

UFGS 07 52 00, *Modified Bituminous Membrane Roofing*

UFGS 07 53 23, *Ethylene Propylene Diene Monomer Roofing*

UFGS 07 54 19, *Polyvinyl Chloride (PVC) Roofing*

UFGS 07 55 00, *Protected Membrane Roofing (PMR)*

UFGS 07 57 13, *Sprayed Polyurethane Foam (SPF) Roofing*

UFGS 07 60 00, *Flashing and Sheet Metal*

UFGS 07 61 01, *Copper Roof System*

UFGS 07 61 14.00 20, *Steel Standing Seam Roofing*

UFGS 07 61 15.00 20, *Aluminum Standing Seam Roofing*

CANCELLED

APPENDIX B BEST PRACTICES

B-1 INTRODUCTION.

This appendix identifies background information, good design practices, and DoD preferences. The designer is expected to review and interpret this guidance and apply the information according to the needs of the project.

B-2 SUSTAINABILITY.

Over the past two decades, responsible roofing professionals have sparked a drive toward greater interest in and adherence to the concept of sustainability. Beyond the desire to improve return on investment on such a significant part of the building envelope, adopting roof systems to fit within environmental parameters has great resonance in modern times.

In the roofing industry, the essence of sustainability is long-term performance. Except for very large roof areas, steep-slope roofs often offer the most life-cycle cost effective solution when considering maintenance, repair, and replacements costs. Military roof systems should be designed to meet the recommended warranty coverages in Appendix D.

As roofing professionals have applied the concept of sustainability to their construction and reroofing projects, they have come to learn that several key areas provided opportunities for improvement. These areas were identified by the CIB (International Council for Research and Innovation in Building Construction) Working Commission W.83 or RILEM (International Union of Testing and Research Laboratories for Materials and Structures) Technical Committee 166RMS (CIBW.83/RILEM166RMS). The areas that were identified include:

- 1) Minimize the burden on the environment by responsible use of materials.
- 2) Conserve energy by improving thermal efficiency of roofs; and
- 3) Extend roof lifespan by improving long-term performance.

B-2.1 21 Tenets of Sustainability.

Within this framework, 21 Tenets of Sustainability were developed for design compliance as follows:

- A. Minimize Burden on the Environment
 1. Use products made from raw materials whose extraction is least damaging to the environment.
 2. Adopt systems and working practices that minimize wastage.
 3. Avoid products that result in hazardous waste.
 4. Recognize regional climatic and geographical factors.

5. Where logical, use products that can be reused or recycled.
6. Promote the use of 'green roofs' supporting vegetation, especially on city center roofs.
7. Consider roof designs that ease the sorting and salvage of materials at the end of the roof life.

B. Conserve Energy

8. Optimize the real thermal performance, recognizing that thermal insulation can greatly reduce heating or cooling costs over the lifetime of a building.
9. Keep insulation dry to maintain thermal performance on durability of the roof.
10. Use local labor, materials and services wherever practical to reduce transportation.
11. Recognize that embodied energy values are a useful measure for comparing alternative constructions.
12. Consider the roof surface color and texture with regard to climate and the effect on energy and roof system performance.

C. Extend Roof Lifespan

13. Employ designers, suppliers, contractors, trades people and facility managers who are adequately trained and have the appropriate skills.
14. Adopt a responsible approach to design, recognizing the value of the robust and durable roof.
15. Recognize the importance of a properly supported structure.
16. Provide effective drainage to avoid ponding.
17. Minimize the number of penetrations through the roof.
18. Ensure that high maintenance items are accessible for repair or replacement.
19. Monitor roofing works in progress and take corrective action, as necessary.
20. Control access onto completed roofs to reduce punctures and other damage, providing defined walkways and temporary protections.
21. Adopt preventative maintenance, including periodic inspections and timely repairs.

B-3 ROOFING SYSTEMS.

B-3.1 Low-slope Roof Drains.

Roof drains should incorporate sump pans provided by the roof drain manufacturer, under-deck clamps to prevent wind uplift, and a clamping ring with bolts. Generally, the best performing roof drains and strainers are made of galvanized cast iron.

B-3.2 Cover boards.

Per Chapter 3, cover boards are required on all low-slope roof systems except ballasted. Note that cover boards also protect the polyisocyanurate insulation from physical damage, improve fire resistance, and provide a suitable surface for adherence of the roof membrane.

B-3.3 Common Metal Roof Panel Profiles.

Figures B-1 and B-2 illustrate some common metal roof panel profiles.

CANCELLED

FIGURE B-1. COMMON METAL ROOF PANEL PROFILES AND CLIPS

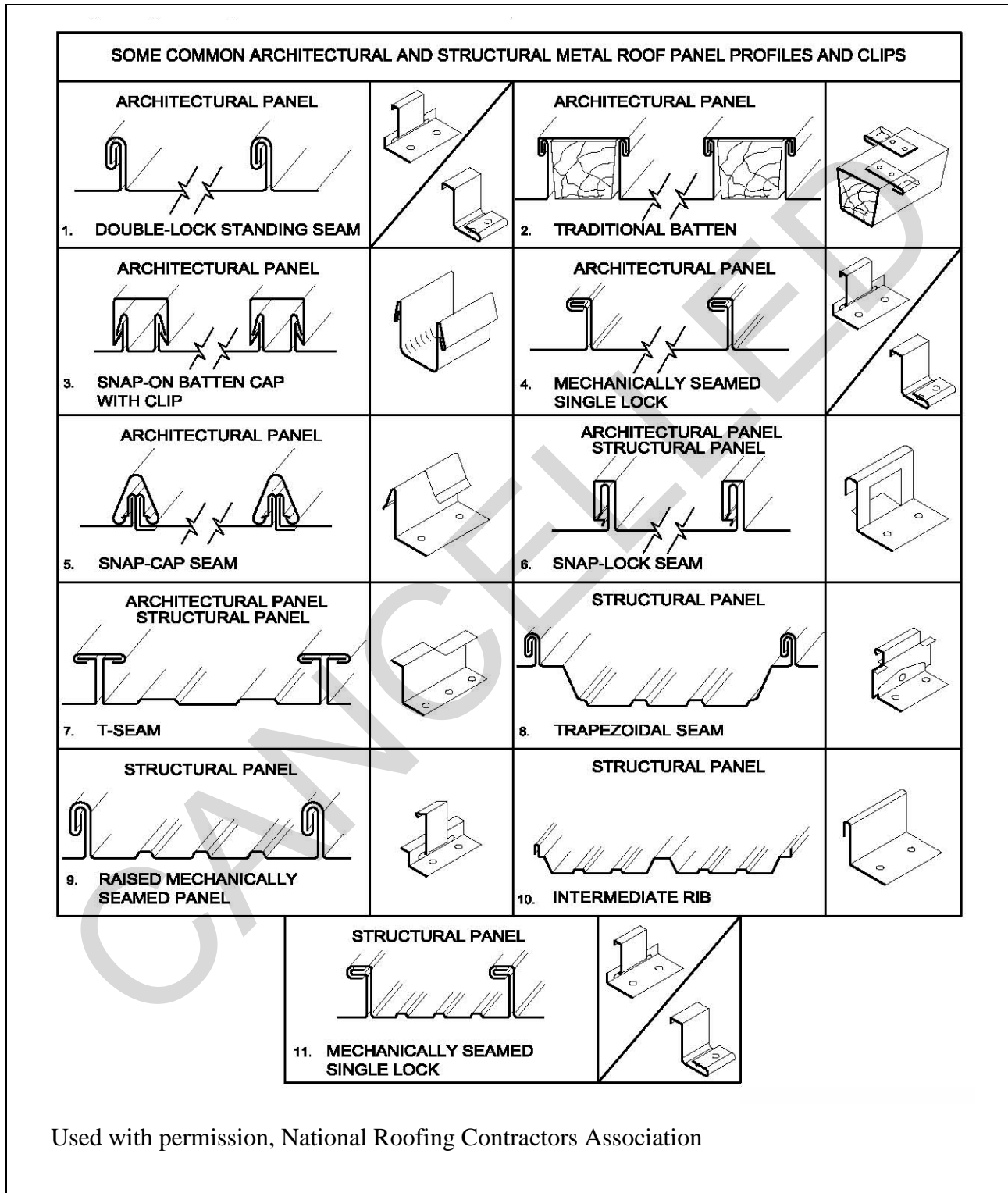

Used with permission, National Roofing Contractors Association

FIGURE B-2. BULB SEAM ZIP RIB

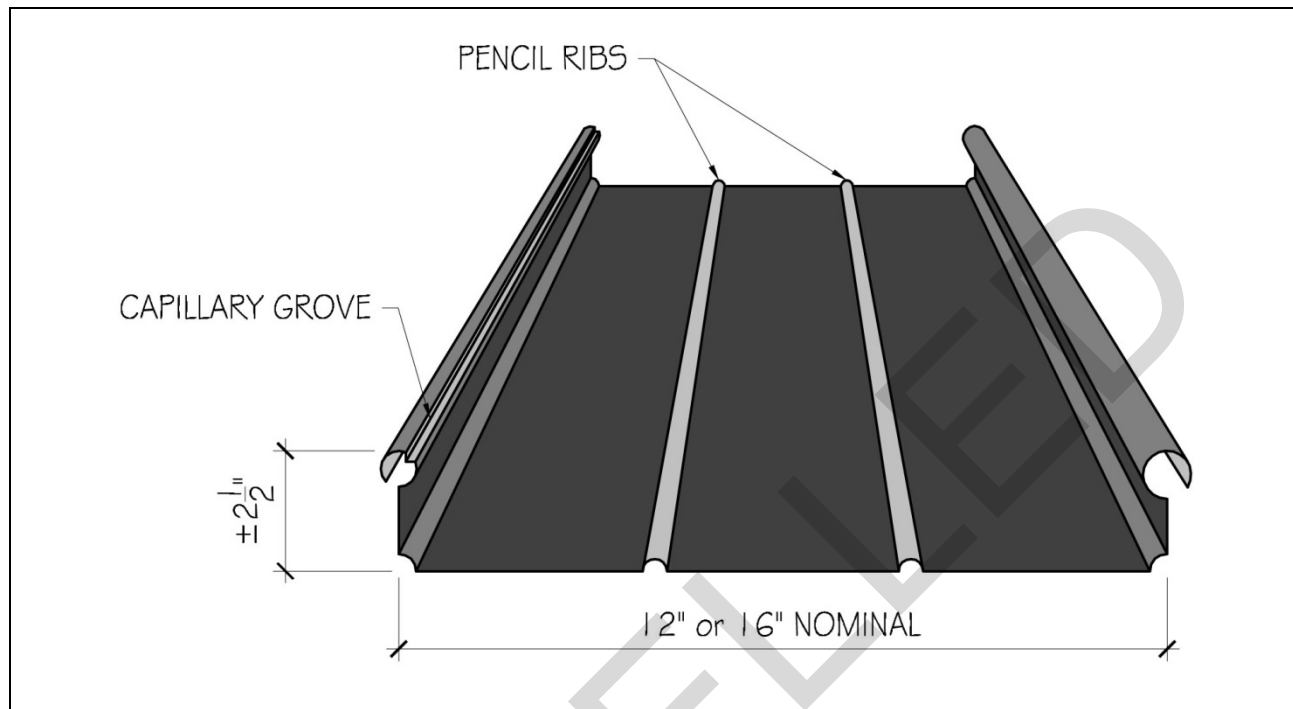

B-4 TEMPORARY ROOFS

Roof system design and construction can often be enhanced by the use of a temporary roof, often a vapor retarder. However, there are conditions and climates where caution must be taken to ensure a second vapor barrier is not created that will trap moisture once the new roof is completed. In southern climates (ASHRAE Climate Zones 1 thru 3), the temporary roof and resulting vapor barrier shall be removed once the new roof is completed. When used appropriately, this design element provides several key quality assurance benefits during new construction:

- Allows for roof related construction such as wood blocking and HVAC work to take place over the temporary roof and not the final roof thus reducing the potential for physical damage to the new roof system.
- Allows for building construction above the roof, such as masonry walls, curtain walls, metal panels, etc., to take place over the temporary roof, thus reducing the potential for physical damage to the new roof system.

Temporary roofs provide the following quality assurance benefits during roof removal projects:

- Permits the full removal of the existing roof without the need to install the new roof in small sections that would result in multiple tie-ins.

- Allows for roof interfacing work such as the installation of new roof drains or renovation of existing roof drains. Wood blocking installation, masonry restoration, HVAC equipment disconnection, curb installation and reinstallation can take place over the temporary roof rather than the new roof system.
- Allows for the large monolithic installation of the new roof system.
- Enhances the roof installation quality.

B-5 ELECTRIC FIELD VECTOR MAPPING (EFVM).

Electric Field Vector Mapping (EFVM) is a non-destructive leak detection method recommended for all waterproofing membranes particularly when waterproofing systems are to be covered with over burden, such as soil for vegetative roofing, pavers for a plaza, or an inverted roofing membrane assembly (IRMA). It is suitable for all waterproofing membranes possessing electrically insulating properties.

B-5.1 How EFVM Works.

EFVM detects the concentration of current flowing across a membrane indicating a breach. If water has flowed through a breach in the membrane, an electrical pathway is set up, which when wetted and energized creates a completed circuit. Whether the membrane is exposed or overburdened, EFVM quickly and accurately locates all breaches.

B-5.2 Locating a Breach in the Membrane.

EFVM locates breaches by measuring electrical flow. One lead from the pulse generator goes to a conductor, placed on the membrane while the other is grounded to the structure. The area of the membrane to be tested is wetted to create continuity that will carry an electrical charge. The trained and certified inspector applies a low voltage electrical potential above and below the membrane in regular pulsed intervals and reads a potentiometer while systematically measuring the current flow at the surface of the roof membrane or any other component of the wet field such as wetted drainage mat, insulation or overburden. Each area of membrane must be thoroughly wetted.

Sensitive equipment reads through all typical water permeable overburden medium such as soil, sand, crushed stone or even pavers and garden plants to measure current flow. Any breach allowing even minute amounts of water past it will conduct electricity, completing a circuit and creating a concentration of current flow measurable by the inspector reading the gauge attached to the probes.

The EFVM trained and certified inspector quickly detects and locates with pinpoint accuracy any individual defect that allows the flow of water from above the membrane to structure. EFVM tests commonly reveal breaches missed by previous flood testing. The contractor can repair the defects found and have them retested within the same day.

B-6 RECYCLING.

The ability to recycle roofing material is now available. When existing roof systems are being removed various components such as the following can be recycled:

- Ballasted and mechanically attached EPDM
- Ballasted and mechanically attached PVC
- Roof related sheet metal
- Extruded and expanded polystyrene
- Chlorosulfonated Polyethylene (CSPE)

Designers are encouraged to specify the recycling of these roof related materials and require certification of same. Refer to the UFGS 01 62 35 on Recycled/Recovered Materials.

B-7 LIFE CYCLE ASSESSMENT.

Consider conducting a Life Cycle Cost Analysis (LCCA) on major roof components, such as the membrane and insulation, to determine the lowest life cycle cost for the component. LCCA is a scientific approach to compiling and evaluating the inputs, outputs and the potential environmental impact of a product or system throughout its life cycle. The environmental impact of all the materials used to manufacture building products, including roofing is slowly making its way into standards. Each product will have a LCCA number and will influence building design in the future. Additional information on LCCA and definition of terms can be found at the American Center for Life Cycle Assessment (ACLCA) web site: www.lcacenter.org/about-lca.aspx

B-8 COOL ROOFING AND HEAT ISLAND ISSUES.

\2\Sustainable Third Party Certifiers (TPC) and industry standards promote the use of cool roofing, and increased energy conservation through additional insulation, when appropriate for climate zone. For cool roof design follow the requirements in Chapter 1, Cool Roofs. /2/ Consider that when cool roofing is used with insulation R values greater than 24, the 'cool roof' surface has little if no influence on the energy performance of the building. Additionally, designers should be aware of the possible negative impacts of using cool roofing that may result in unintended consequences.

Poor design of cool roofs in ASHRAE climate zones 4 and higher have resulted in the unintended consequence of condensation below the membrane—a result of the material's inability to warm and drive moisture downward. Roofs that experience this condensation have had to be replaced. Other unintended consequences include the overheating of masonry walls, interior spaces, roof top piping and mechanical equipment because of the reflected UV rays.

B-9 GUTTERS AND DOWNSPOUTS.

Consider methods to ensure gutters and downspouts do not become clogged. The best options for DoD projects include oversizing downspouts, minimizing turns or offsets in the downspouts, providing strainers at the downspouts, and providing clean-outs at the base of the downspouts. Strainers should not be used in areas with a lot of leaves or tree debris.

B-10 PARAPETS.

If parapets are to be used, the metal coping will have an ice and water shield membrane completely lapping the wall from edge to edge. If a stone/masonry coping is used, it will have through wall flashing under the coping including watertight welded caps over the posts used to secure the coping stone.

On all masonry drainage plane walls with roofs running beside, stepped through wall flashing will be provided to protect the interior wall below.

B-11 DESIGN PROFESSIONAL QUALIFICATIONS.

In addition to the criteria required in Chapter 1, all projects that have more than 15,000 ft.² (1400 m²) of roof area or that are defined as “critical use” or “mission critical” in the project DD Form 1391 should have an RRC or a registered PE or RA that derives his or her principal income from roofing design on the design team.

B-12 REROOFING.

Re-roofing can be considered a problem or an opportunity. Re-roofing can be a problem since the work is typically performed while the structure is occupied. Often there are concerns with noise, fumes, access, and interruption of building use. Re-roofing can be an opportunity since there is no better time to upgrade the roof system than while re-roofing. Changes in the roof system may be mandated by revisions to ASCE 7 or by needed improvement in drainage or thermal performance. It can be an opportunity to elevate or redesign problem roof elements, to install deck supported curbs that are flashed independently of the wall (resolving persistent flashing problems due to differential movement), and to resolve condensation problems or thermal insulation deficiencies.

Re-roofing decisions begin with a survey of existing conditions. This may include visual inspection, infrared moisture surveys, and roof cut analysis. Structural analysis may also be required, especially if a different type of roof is contemplated which affects dead load, drainage, or seismic behavior. One method of analyzing the condition of an existing roof is to use the ROOFER *Sustainment Management System* (SMS). The ROOFER SMS is a decision-making tool to help manage an installation’s low-slope membrane and asphalt shingle roofing assets. It includes procedures for collecting inventory and inspection information, evaluating roof conditions, identifying repair/replacement strategies, prioritizing projects, and developing work plans.

ROOFER, a Web-based application, provides data storage and analysis and generates management reports.

B-13 RECOVERING.

Re-covering of existing low-slope roofs is not recommended. When the best option based on a detailed analysis, including risk analysis, LCCA, and a moisture survey, is to recover a low-slope roof, comply with the criteria in Chapter 6.

Re-cover of existing built-up and MB roofing may take the form of mechanically or spot attaching a base sheet (to aggregate-free substrates), or mechanically or spot attaching re-cover insulation when aggregate is present (where only the loose aggregate is removed). Full attachment to a severely compromised membrane is never recommended. \2\

B-14 TPO ROOFING

TPO Roofing has energy efficient properties as well as being recyclable. These features and cost effectiveness makes TPO membranes an attractive roof system for large scale industrial applications. Below are some considerations for obtaining the best life cycle performance when this roof type is selected:

- Reduce the number of rooftop mounted items which significantly reduce the number of roofing membrane penetrations.
- Wherever penetrations in the roofing membrane must occur, encapsulate penetration by using either a preformed TPO boot or a pitch pocket. This method of encapsulation should be used whether the penetration is vertical or horizontal.
- Require test strips for the membrane hot air welder on any day the contractor is performing hot air welding of seams. The test strips can be inspected to assure that the machine is hot enough and reduces chances of non-adhered seams.
- Scuppers contained in the TPO roof system require hand welded seams. Special attention should be given to performing inspection in these areas due to the space constraints to assure the membrane is fully adhered.
- It is important to address/control fall protection early in the project to avoid having to install fall protection measures that penetrate the TPO membrane after installation or use heavy objects that may get dragged across the TPO membrane.
- Due to TPO membranes being a single-ply system, it is important to ensure that any structural components that are underneath the membrane and may

rub against the membrane are fully protected so that they do not inadvertently puncture the membrane. An example may be structural welded plates or other components along the perimeter edge of the roof. /2/

CANCELLED

APPENDIX C GLOSSARY, ACRONYMS AND ABBREVIATIONS

- ACM.** Asbestos containing material
- ANSI.** American National Standards Institute
- APP.** Atactic Polypropylene
- ASCE.** American Society of Civil Engineers
- ASHRAE.** American Society of Heating, Refrigerating and Air Conditioning Engineers
- ASTM.** American Society of Testing and Materials
- BUR.** Built-up roof
- CERL.** Construction Engineering Research Laboratories
- CONUS.** Continental United States
- CRREL.** Cold Regions Research and Engineering Laboratory
- CSSB.** Cedar Shake and Shingle Bureau
- DB.** Design Build \2\
- DD 1391.** Department of Defense Form 1391
- DoD.** Department of Defense
- DON.** Department of the Navy /2/
- EFVM.** Electric field vector mapping
- EPDM.** Ethylene Propylene Diene Monomer
- EPS.** Molded expanded polystyrene board.
- ERA.** EPDM Roofing Association
- FM.** Factory Mutual
- HVAC.** Heating, ventilation, and air conditioning
- IBC.** International Building Code
- IGCC.** International Green Construction Code
- LCCA.** Life cycle cost analysis \2\ /2/

MB. Modified bitumen

MBMA. Metal Building Manufacturers Association

MREC. Mesh Reinforced Elastomeric Roof Coating

NRCA. National Roofing Contractors Association

NSA. National Slate Association

OSHA. Occupational Safety and Health Administration

PE. Professional engineer

PUF. Polyurethane foam (also see SPF)

PV. Photovoltaic

PVC. Polyvinyl chloride

PVDF. Polyvinylidene fluoride (also PVF)

PVF. Polyvinylidene fluoride (also PVDF)

RA. Registered architect

RCI. Roof Consultants Institute

RICOWI. Roofing Industry Committee on Weather Issues

RRO. Registered roofing observer

RRC. Registered roofing consultant

SBS. Styrene Butadiene Styrene

SHPO. State Historic Preservation Office

SMACNA. Sheet Metal and Air Conditioning Contractors National Association

SME. Subject matter expert

SMS. Sustainment Management System

SPF. Spray-applied polyurethane foam (also see PUF)

SPRI. Single Ply Roofing Industry

SSSMR. Structural standing-seam metal roof

TPO. Thermoplastic Polyolefin

TRI. Tile Roofing Institute

UFC. Unified Facilities Criteria

UFGS. Unified Facilities Guide Specification

UV. Ultraviolet

XPS. Extruded polystyrene board

UL. Underwriters Laboratories Incorporated

DEFINITIONS

See UFC 3-101-01 and the NRCA Roofing Manual for a more complete list of definitions.

Aggregate. (1) Crushed stone, crushed slag, or water-worn gravel used for surfacing a built-up roof. (2) Any granular mineral material.

Alloys, polymeric. A blend of two or more polymers, e.g., a rubber and a plastic to improve a given property, e.g., impact strength.

Asphalt. A dark brown to black elastomeric cementitious material whose predominating constituents are bitumen's that occur in nature or are obtained in petroleum processing.

Asphalt felt. An asphalt-saturated felt.

Atactic. A chain of molecules in which the position of the side methyl groups is more or less random. (Amorphous; Low Crystallinity)

Ballast. Loose aggregate, concrete pavers, or other material designed to prevent wind uplift or flotation of a loose-laid roof system.

Base sheet. A saturated or coated felt placed as the first ply in a multi-ply bituminous roofing membrane.

Batten. (1) Raised rib, in a metal roof, or a separate part or formed portion in a metal roofing panel. (2) One of a series of strips laid in a matrix under tile roof applications.

Bitumen. (1) A class of amorphous, black or dark colored, (solid, semisolid, or viscous) cementitious substances natural or manufactured, composed principally of high molecular weight hydrocarbons, soluble in carbon disulfide, and found in asphalts, tars,

pitches, and asphaltites; (2) A generic term used to denote any material composed principally of bitumen; (3) In the roofing industry there are two basic bitumens: asphalt and coal-tar pitch. Before application, they are either (a) heated to a liquid state, (b) dissolved in a solvent, or (c) emulsified.

Bituminous (adj.). Containing or treated with bitumen. Examples: bituminous concrete, bituminous felts and fabrics, bituminous pavement.

Bond. The adhesive and cohesive forces holding two roofing components in intimate contact.

Boot. A bellows type covering to exclude dust, dirt, moisture, etc., forming a flexible closure.

British thermal unit (BTU). Heat energy required to raise the temperature of one pound of water by 1⁰F (= 1055 joules).

Building Code. Published regulations and ordinances established by a recognized agency describing design loads, procedures, and construction details for structures. Usually applying to designated political jurisdiction (city, county, state, etc.). Building codes control design, construction, and quality of materials, use and occupancy, location and maintenance of buildings and structures within the area for which the code was adopted (see Model Codes).

Built-Up Roofing (BUR). A continuous, semiflexible membrane consisting of plies of saturated felts, coated felts, fabrics or mats assembled in place with alternate layers of bitumen, and surfaced with mineral aggregate, bituminous material, or a granule surfaced sheet (abbreviation, BUR).

Butyl Rubber. A synthetic rubber based on isobutylene and a minor amount of isoprene. It is vulcanizable and features low permeability to gases and water vapor and good resistance to aging, chemicals and weathering.

Cant. In SPF-based roofing, a beveling of foam at horizontal/vertical joints to increase strength and promote water runoff.

Cant strip. A beveled strip used under flashings to modify the angle at the point where the roofing or waterproofing membrane meets any vertical element.

Capflashing. See Flashing.

Capsheet. A granule-surfaced coated felt used as the top ply of a built-up roofing membrane.

Caulk. To seal joints, seams, or voids by filling with a waterproofing compound or material.

Caulking. A composition of vehicle and pigment, used at ambient temperatures for filling joints, that remains plastic for an extended time after application.

Chalk Resistance. A measurement of performance for paint systems; the ability to resist a dusty/chalky appearance over time.

Chalking. A powdery residue on the surface of a material resulting from degradation or migration of an ingredient, or both.

Chlorinated polyethylene (CPE). Family of polymers produced by chemical reaction of chlorine on the linear backbone chain of polyethylene. The resultant rubbery thermoplastic elastomers presently contain 25- 45 % chlorine by weight and 0-25% crystallinity. CPE can be vulcanized but is usually used in a nonvulcanized form.

Chlorosulfonated polyethylene (CSPE). Family of polymers that are produced by polyethylene reacting with chlorine and sulfur dioxide. Present polymers contain 25-43% chlorine and 1.0-1.4% sulfur. They are used in both vulcanized and nonvulcanized forms. Most membranes based on CSPE are nonvulcanized. ASTM designation for this polymer is CSM. Best known by the DuPont Tradename "Hypalon."

Closure Strip. A resilient strip such as neoprene, flat on one side and formed to the contour of ribbed sheets on the other, used to close openings created by joining metal sheets and flashings.

Coal Tar. A dark brown to black cementitious material produced by the destructive distillation of coal.

Coal Tar Felt. A felt saturated with refined coal tar.

Coating Weight. Weight of coating on surface (both sides), usually expressed in g/m² or oz./ft.².

Coefficient of Thermal Expansion. The change in length per unit of length for a unit change in temperature. (Thus the coefficient per °F must be multiplied by 1.8 for the coefficient per °C.)

Condensation. The conversion of water vapor or other gas to liquid as the temperature drops or atmospheric pressure rises (see also Dew point).

Conductance, Thermal. The thermal transmission in unit time through unit area of a particular body or assembly having defined surfaces, when unit average temperature difference is established between the surfaces. $C=(W/ m^2 \cdot K)$ $C=(Btu/h \cdot ft^2 \cdot ^\circ F)$.

Conductivity, Thermal. The time rate of transfer of heat by conduction through a unit thickness across unit area for unit difference of temperature.

Copolymer. A mixed polymer, the product of polymerization of two or more substances at the same time.

Counterflashing. Formed metal or elastomeric sheeting secured on or into a wall, curb, pipe, rooftop unit, or other surface, to shield the upper edge of a base flashing and its associated fasteners.

Coverage. The surface area to be continuously covered by a specific quantity of a particular material.

Covering. The exterior roof and wall covering for a metal building system.

Cricket. A relatively small, elevated area of a roof constructed to divert water from a horizontal intersection of the roof with a chimney, wall, expansion joint or other projection.

Curb. A raised member used to support roof penetrations such as skylights, hatches, etc.

Cure. To change the properties of a polymeric system into a more stable, usable condition by the use of heat, radiation, or reaction with chemical additives. NOTE: Cure may be accomplished, for example, by removal of solvent or cross-linking.

Deck. The structural substrate to which the roofing or waterproofing system (including insulation) is applied.

Degree-Days. The sum of the positive or negative differences between a reference temperature (usually 18°C (65°F)) and the mean temperature for each day in the heating or cooling season). Degree-days are used to compare the severity of cold or heat during the heating or cooling season

Delamination. Separation of the plies in a membrane or separation of insulation layers after lamination.

Design loads. The “live load” and “environmental load” (i.e. superimposed loads) that a structure is designed to resist (with appropriate safety factor) plus “dead load” (i.e., weight of permanent loads).

Dew point. The temperature at which water vapor starts to condense in cooling air at the existing atmospheric pressure and vapor content.

Dry (n.). A material that contains no more water than one would find at its equilibrium moisture content.

Eave. The line along the sidewall formed by the intersection of the planes of the roof and wall.

Eave Height. The vertical dimension from finished floor to the eave.

Edge venting. The practice of providing regularly spaced protected openings at a low-slope roof perimeter to relieve water vapor pressure in the insulation. (It is of doubtful efficacy.)

Elasticity. The property of matter by virtue of which it regains its original size and shape after removal of stress.

Elastomer. A macromolecular material that returns rapidly to its approximate initial dimensions and shape after subsequent release of stress.

Embedment. (1) the process of pressing a felt, aggregate, fabric, mat, or panel uniformly and completely into hot bitumen or adhesive to ensure intimate contact at all points; (2) the process of pressing granules into coating in the manufacture of factory prepared roofing, such as shingles.

Emulsion. A dispersion of fine particles or globules of a liquid in a liquid. Asphalt emulsions consist of asphalt globules, an emulsifying agent such as bentonite clay and water.

Endlap. The overlap where one panel or felt nests on top of the end of the underlying panel or felt.

EPDM. A synthetic elastomer based on ethylene, propylene, and a small amount of a non-conjugated diene to provide sites for vulcanization. EPDM features excellent heat, ozone and weathering resistance, and low temperature flexibility.

EVA. Family of copolymers of ethylene and vinyl acetate used for adhesives and thermoplastic modifiers. They possess a wide range of melt indexes.

Fabric. A woven cloth of organic or inorganic filaments, threads, or yarns.

Fabrication. (1) The manufacturing process performed in a plant to convert raw material into finished metal building components. The main operations are cold-forming, cutting, punching, welding, cleaning, and painting; (2) the creation of large panels of rubber from smaller calendar width sheets as in EPDM.

Fascia. A decorative trim or panel projecting from the face of a wall, serving as a weather closure at gable and endwall.

Felt. A flexible sheet manufactured by the interlocking of fibers through a combination of mechanical work, moisture, and heat, without spinning, weaving, or knitting. Roofing felts are manufactured from vegetable fibers (organic felts), glass fibers (glass fiber felts) or polyester fibers (synthetic fiber mats).

Fiberglass insulation. Blanket insulation, composed of glass fibers bound together with a thermoset binder, faced or unfaced, used over or under purlins to insulate roofs and walls; semi-rigid boards, usually with a facer.

Field. The “job site,” “building site,” or general market area.

Fixity. Fixity is the location in which a single metal roof panel is attached to the building structure and is the point from which all thermal expansion radiates. The line of fixity is the line created from the individual points of fixity.

Flashing. The system used to seal membrane edges at adjacent perpendicular surfaces (walls), expansion joints, drains, gravel stops, and other places where the membrane is interrupted or terminated. Base flashing covers the edges of the membrane. Cap or counterflashing shields the upper edges of the base flashing.

Flood coat. The top layer of bitumen used to hold the aggregate on an aggregate surfaced roofing membrane.

Fluid-applied elastomer. An elastomeric material, fluid at ambient temperature, that dries or cures after application to form a continuous membrane. Such systems may not incorporate reinforcement.

Galvalume. Trade name for steel coated with aluminum-zinc alloy for corrosion protection (55% AlZn).

Galvanized steel. Steel coated with zinc for corrosion resistance.

Glass felt. Glass fibers bonded into a sheet with resin and suitable for impregnation in the manufacture of bituminous waterproofing, roofing membranes, and shingles.

Granule. See Mineral Granules.

Gravel. Coarse, granular aggregate, with pieces larger than sand grains, resulting from the natural erosion of rock.

Green Building Technology. Technology that reduces impact on the earth. Includes recyclability, reduction in carbon dioxide, ozone or other atmospheric pollutants, and reduction of urban heat islands.

Gutter. A channel member installed at the eave of the roof for the purpose of carrying water from the roof to the drains or down spouts.

Heat Seaming. The process of joining two or more thermoplastic films or sheets by heating areas in contact with each other to the temperature at which fusion occurs. The process is usually aided by a controlled pressure. In dielectric seaming, the heat is induced within films by means of radio frequency waves.

Heat transfer. The transmission of thermal energy from a location of higher temperature to a location of lower temperature. This can occur by conduction, convection or radiation.

Humidity. The amount of moisture contained in the atmosphere. Generally expressed percent relative humidity. (The ratio of the vapor pressure to the saturation pressure for given conditions times 100.)

Hydrocarbons. An organic chemical compound containing mainly the elements carbon and hydrogen. Aliphatic hydrocarbons are straight chain compounds of carbon and hydrogen. Aromatic hydrocarbons are carbon-hydrogen compounds based on the cyclic or benzene ring. They may be gaseous (CH₄, ethylene, butadiene), liquid (hexene, benzene), or solid (Natural rubber, naphthalene, cispolybutadiene).

Hydrokinetic Metal Roof System. This is a metal roof system in which the metal standing seam, eaves and valleys accommodate expansion and are constructed in a way which allows some water infiltration. The infiltrating water is drained through weeps in the roof assembly and with a watertight underlayment membrane under the roof. The fixity will typically be at the ridge in this roof system.

Hydrostatic Metal Roof System. The metal standing seam, laps at the eave and valley are construction with positive attachment and non-curing sealant to provide a watertight assembly in this metal roof system. Fixity will typically be at the eave and valleys in this roof system.

Inorganic (adj.). Comprising matter other than hydrocarbons and their derivatives, or matter not of plant or animal origin.

Insulation. See Thermal Insulation.

Internal Pressure. Pressure inside a building, a function of wind velocity, building height, and number and location of openings.

Isocyanate. A highly reactive chemical grouping composed of a nitrogen atom bonded to a carbon atom bonded to an oxygen atom: =N=C=O; a chemical compound, usually organic, containing one or more isocyanate groups.

Isoboard. Abridgement of polyisocyanurate foam insulation board.

Lap. Dimension by which a felt covers an underlying felt in BUR membrane. "Edge" or side lap indicates the transverse cover; "End" lap indicates the cover at the end of the roll. These terms also apply to single-ply membranes.

Lapped joint. A joint made by placing one surface to be joined partly over another surface and bonding the overlapping portions.

Loose-laid Membrane. An unadhered roofing membrane anchored to the substrate only at the edges and penetrations through the roof and ballasted against wind uplift by loose aggregate or pavers.

Mastic. Caulking or sealant normally used in sealing roof panel laps.

Membrane. A flexible or semi-flexible roof covering or waterproofing whose primary function is the exclusion of water.

Metal flashing. See Flashing—frequently used as through-wall, cap, or counterflashing.

Mineral fiber. Inorganic fibers of glass, asbestos or mineral wool (slag).

Mineral granules. Natural or synthetic aggregate, ranging in size from 500 μ m (1 μ m = 10-6m) to 1/4 in. diameter, used to surface BUR or modified bitumen cap sheets, asphalt shingles, and some cold process membranes.

Model Codes. Codes established to provide uniformity in regulations pertaining to building construction. Example: International Building Code published by the ICC.

Moisture conduction. Migration by wicking as contrasted to vapor movement.

Monomer. A simple molecule which is capable of combining with a number of like or unlike molecules to form a polymer.

Mopping. Application of hot bitumen with a mop or mechanical applicator to the substrate or to the plies of a built-up or modified-bitumen roof. There are four types of mopping: (1) solid—a continuous coating; (2) spot—bitumen is applied in roughly circular areas, generally about 460 mm (18 in.) in diameter, leaving a grid of unmopped, perpendicular area, (3) strip—bitumen is applied in parallel bands, generally 200 mm (8 in.) wide and 300 mm (12 in) apart; (4) sprinkle—bitumen is shaken on the substrate from a broom or mop in a random pattern.

Nailer. Wood member bolted or otherwise anchored to a nonnailable deck or wall to provide nailing anchorage of membrane or flashing.

Nailing. (1) Exposed nailing of roofing wherein nail heads are bare to the weather; (2) Concealed nailing of roofing wherein nail heads are concealed from the weather (see also blind nailing).

Neoprene. Synthetic rubber (polychloroprene) used in liquid or sheet-applied elastomeric roofing membranes or flashing.

Nondestructive Testing (NDT). Methods for evaluating the strength or composition of materials without damaging the object under test.

Nonwoven Fabric. A sheet material produced by bonding or interlocking of fibers (or both) by mechanical, thermal or solvent means (or combinations thereof).

Olefin. An unsaturated open-chain hydrocarbon containing at least one double bond: ethylene or propylene.

Olefin Plastics. Plastics based on polymers made by the polymerization of olefins or copolymerization of olefins with other monomers, the olefins being at least 50 percent of the mass.

Organic (adj.). Composed of hydrocarbons or their derivatives; or matter of plant or animal origin.

Organic coating. Coatings that are generally inert or inhibited. May be temporary (e.g., slushing oils) or permanent (paints, varnishes, enamels, etc.).

Organic content. Usually synonymous with volatile solids in an ashing test; e.g., a discrepancy between volatile solids and organic content can be caused by small traces of some inorganic materials, such as calcium carbonate, that lose weight at temperatures used in determining volatile solids.

Panel clip. Independent clip used to attach roof panels to substructure.

Panel Creep. Tendency of the transverse dimension of a roof panel to gain in modularity due to spring-out or storage-distortion.

Parapet. Portion of wall above the roofline.

Pea Gravel. Small gravel with a diameter approaching that of a pea. Size roughly defined by ASTM D448 *Standard Classification for Sizes of Aggregate for Road and Bridge Construction*, Number 7 or smaller.

Peak. The uppermost point of a gable.

Penetration. The consistency of a bituminous material expressed as the distance in tenths of a millimeter (0.1 mm) that a standard needle or cone vertically penetrates a sample of material under specified conditions of loading, time, and temperature.

Percent Elongation. In tensile testing, the increase in the gauge length, measured after fracture of the specimen within the gauge length.

Perlite. An aggregate used in lightweight insulating concrete and in preformed perlite insulating board, formed by heating and expanding siliceous volcanic glass.

Permeability. (1) The capacity of a porous medium to conduct or transmit fluids; (2) The amount of liquid moving through a barrier in a unit time, unit area and unit pressure gradient not normalized for but directly related to thickness; (3) The product of vapor

permeance and thickness (for thin films, ASTM E96-00e1 *Standard Test Methods for Water Vapor Transmission of Materials*—over 3.2 mm (.125 in.), ASTM C355 Usually reported in perm inches or grain/h•ft²•in. Hg per inch of thickness. 1 perm inch = 1.46 x 10⁻¹² kg/Pa•s•m.

Permeance. The rate of water vapor transmission per unit area at a steady state through a membrane or assembly, expressed in ng/Pa•s•m² (grain/ft²•h•in. Hg).

Phenolic Plastics. Plastics based on resins made by the condensation of phenols, such as phenol and cresol, with aldehydes.

Pitch. See Incline, Coal tar pitch, or Petroleum pitch.

Plastic. A material that contains as an essential ingredient one or more organic polymeric substances of large molecular weight. It is solid in its finished state and at some stage in its manufacture or processing into finished articles can be shaped by flow.

Plasticizer. Material, frequently solvent-like, incorporated in a plastic or a rubber to increase its ease of workability, flexibility, or extensibility. Adding the plasticizer may lower the melt viscosity, the temperature of the second order transition, or the elastic modulus of the polymer.

Plasticizers. May be monomeric liquids (phthalate esters), low molecular weight liquid polymers (polyesters) or rubbery high polymers (EVA). The most important use of plasticizers is with PVC where the choice of plasticizer dictates under what conditions the membrane may be used.

Ply. A layer of felt in a roofing membrane; a four-ply membrane should have at least four plies of felt at any vertical cross section cut through the membrane.

Plywood. A flat panel built up of sheets of wood veneer called plies, united under pressure by a bonding agent to create a panel with an adhesive bond between plies as strong as or stronger than, the wood. Plywood is constructed of an odd number of layers with grain of adjacent layers perpendicular. Layers may consist of a single ply or two or more plies laminated with parallel grain direction. Outer layers and all odd numbered layers generally have the grain direction oriented parallel to the long dimension of the panel.

Polyester Fiber. Generic name for a manufactured fiber in which the fiber-forming substance is any long chain synthetic polymer composed of an ester of a dihydric alcohol and terephthalic acid. Scrims made of polyester fiber are used for fabric reinforcement.

Polyisobutylene. The polymerization product of isobutylene varying in consistency from a viscous liquid to a rubberlike solid, with corresponding variation in molecular weight from 1,000 to 400,000.

Polyisocyanurate. Thermoset polymer formed by polymerization of isocyanate; rigid foam insulation meeting ASTM C1289 *Standard Specification for Faced Rigid Cellular Polyisocyanurate Thermal Insulation Board*; a thermal insulation similar in appearance to polyurethane foam, but with improved fire resistance or rating.

Polymer. A macromolecular material formed by the chemical combination of monomers having either the same or different chemical composition. Plastics, rubbers, and textile fibers are all high molecular weight polymers.

Polyvinyl Chloride (PVC). A synthetic thermoplastic polymer prepared from vinylchloride. PVC can be compounded into flexible and rigid forms through the use with plasticizers, stabilizers, filler, and other modifiers; rigid forms used in pipes; flexible forms used in manufacture of sheeting.

Ponding. Water in low or irregular roof areas that remains longer than 48 hours after the cessation of rainfall, under conditions conducive to evaporation.

Preventive Maintenance. The regular, scheduled, inspection for and the repair of normal, expected breakdown of materials and equipment.

Prime coat. First liquid coat applied in a multiple coat system.

Primer (bituminous). A thin liquid bitumen applied to a surface to improve the adhesion of heavier applications of bitumen and to absorb dust.

Protected Membrane Roof (PMR). Roof assembly with insulation on top of membrane instead of vice versa, as in conventional roof assembly (also known as inverted or upside-down roof assembly).

Puncture Resistance. Index of a material's ability to withstand the action of a sharp object without perforation.

R-Factor. Resistance to heat flow. The summation of individual thermal resistances in an assembly.

Rake. The sloped edge of a roof at the first or last rafter.

Rake trim. A flashing designed to close the opening between the roof and endwall panels.

Re-covering. The process of covering an existing roof system with a new roof.

Reglet. A groove in a wall or other surface adjoining a roof surface for the insertion and attachment of counterflashing.

Relative Humidity. The ratio of the mass per unit volume (or partial pressure) of water vapor in an air-vapor mixture to the saturated mass per unit volume (or partial pressure) of the water vapor at the same temperature, expressed as a percentage.

Replacement. The removal of all roof system components down to the structural deck followed by installation of a completely new roofing system.

Reroofing. Replacement or re-cover of an existing roof system.

Resistance, Thermal. See Thermal resistance.

Retrofit. The modification of an existing building or facility to include new systems or components.

Ridge. Highest point on the roof of the building, a horizontal line running the length of the building.

Ridge Cap. A transition of the roofing materials along the ridge of a roof. Sometimes called ridge roll or ridge flashing.

Roll Goods. A general term applied to rubber and plastic sheeting, usually furnished in rolls.

Roll Roofing. Coated felts, either smooth or mineral surfaced.

Roof Curb. An accessory used to mount and level units (such as air conditioning and exhaust fans) on the sloped portion of the building roof.

Roof Jack. An accessory used to cover pipes (such as vents or flues) that penetrate the roof covering.

Roof Seamer. Machine that crimps panels together or that welds laps of E/P systems using heat, solvent or dielectric energy.

Roof Slope. The angle a roof surface makes with the horizontal, measured in a ratio such as ½:12.

ROOFER Sustainment Management System (SMS). The ROOFER SMS is a practical decision-making tool to help manage an installations or bases low-slope membrane and asphalt shingle roofing assets. It includes procedures for collecting inventory and inspection information, evaluating roof condition, identifying repair/replacement strategies, prioritizing projects, and developing work plans. Micro ROOFER, software provides data storage and analysis, and generates management reports. Contact the Service-specific SME to gain access to ROOFER SMS.

Roofing System. A combination of interacting components designed to weatherproof, and normally to insulate, a building's top surface; does not include the roof deck.

Rubber. A material capable of quickly recovering from large deformations, normally insoluble in boiling solvent such as benzene, methyl ethyl ketone, and ethanol toluene azeotrope. A rubber in its modified state retracts within 1 mm to less than 1.5 times its original length after being stretched to twice its length.

Sacrificial Protection. Reducing the extent of corrosion of a metal in an electrolyte by coupling it to another metal that is electrochemically more active in the environment, i.e., galvanic protection.

Scupper. Channel through a low-slope roof edge or parapet, designed for peripheral drainage of the roof, usually a safety overflow to limit accumulation of ponded rainwater caused by clogged drains or intense rainfall.

Scrim. A woven, open mesh reinforcing fabric made from continuous filament yarn. Used in the reinforcement of polymeric sheeting.

Sealant. Any material used to close up cracks or joints to protect against leaks. Lap sealant is applied to exposed lap edges in E/P systems.

Sealing Washer. A metal-backed rubber washer assembled on a screw to prevent water from migrating through the screw hole.

Seam Strength. Strength of a seam of material measured either in shear or peel modes, reported either in absolute units, e.g., pounds per inch of width—or as a percent of the sheeting strength.

Service Life. Anticipated useful life of a building, building component or building subsystem (e.g., roof system).

Shelf Life. Maximum safe time to store a fluid construction material or non-cured sheet before use.

Shingle. (1) A small unit of prepared roofing designed for installation with similar units on overlapping rows on inclines normally exceeding 25%; (2) To cover with shingles, and (3) To apply any sheet material in overlapping rows like shingles.

Shingling. (1) The procedure of laying parallel felts so that one longitudinal edge of each felt overlaps, and the other longitudinal edge underlaps an adjacent felt. (See also Ply). Normally, felts are shingled on a slope so that the water flows over rather than against each lap; (2) The application of shingles to a sloped roof.

SI. The international symbol for the metric unit (Le Systeme International d'Unites).

Sidelap. The continuous overlap of closures along the side of a panel or sheet material.

Sill. The bottom horizontal framing member of an opening such as a window or door.

Single Slope. A sloping roof with one surface. The slope is from one wall to the opposite wall of rectangular building.

Skylight. A roof accessory to admit light, normally mounted on a curbed, framed opening.

Slippage. Relative lateral movement of adjacent felts (or sheets) in a roof membrane. It occurs mainly in roofing membranes on a slope, sometimes exposing the lower plies or even the base sheet to the weather.

Slope. Tangent of the angle between the roof surface and the horizontal plane, expressed as a ratio. (See also roof slope)

Smooth Surfaced Roof. A roof membrane without mineral aggregate surfacing.

Soffit. The underside covering of any exterior overhanging section of a roof, gable or sidewall.

Softening Point. Temperature at which a bitumen becomes soft enough to flow as determined by an arbitrary, closely defined method.

Square. A roof area of 100 ft² (9.29 m²), or enough material to cover 100 ft² (9.29 m²) of deck.

Stack Vent. A vertical outlet designed to relieve pressure exerted by water vapor between a membrane and the vapor retarder or deck.

Stainless Steel. An alloy of steel which contains a high percentage of chromium. Also may contain nickel or copper. Has excellent resistance to corrosion.

Standing Seam. Watertight seam type featuring an upturned rib, which may also be structural. It is made by turning up the edges of two adjacent metal panels and then folding them over in one of a variety of ways.

Stress. (1) A measure of the load on a structural member in terms of force per unit area (MPa) (kips per in.²); (2) The force acting across a unit area in solid material in resisting the separation, compacting or sliding that tends to be induced by external forces. Also the ratio of applied load to the initial cross sectional area, or the maximum stress in the outer fibers due to an applied flexural load.

Stress Concentration. A condition in which stress is highly localized, usually induced by an abrupt change in the shape of a member or at a substrate joint (e.g., between insulation joints)

Substantial Completion. The stage in the progress of the work when it is sufficiently complete for the owner to occupy or utilize the space for its intended use.

Surface Cure. Curing or vulcanization which occurs in a thin layer on the surface of a manufactured polymeric sheet or other items.

Susceptibility. When not otherwise qualified, the degree of change in viscosity with temperature.

Tearoff. Removal of a failed roof system down to the structural deck surface.

Tensile Strength. (1) The maximum tensile stress per unit of original cross sectional area applied during stretching of a specimen to break; units: SI-metric—Megapascal or kilopascal, customary—lb per in.²; (2) The longitudinal pulling stress a material can bear without tearing apart; (3) The ratio of maximum load to original cross-sectional area. Also called ultimate strength.

Tensile Test. A test in which a specimen is subjected to increasing longitudinal pulling stress until fracture occurs.

Therm. A unit of heat commonly used by utilities, equivalent to 100,000 BTU = 1.05 x 10⁸ joules.

Thermal Conductivity (k). The rate of heat flow through a stated thickness of material with a stated temperature differential Btu/h.ft²•°F (W/m²•°C).

Thermal Insulation. A material designed to reduce the conductive heat flow.

Thermal Resistance (R). Resistance to heat flow. The reciprocal of conductance (C).

Thermal Shock. Stress-producing phenomenon resulting from sudden temperature drops in a roof membrane—when, for example, a rain shower follows brilliant sunshine.

Thermoplastic Elastomers. Polymers capable of remelt, but exhibiting elastomeric properties; related to elasticized polyolefins. They have a limited upper temperature service range.

U-Factor. The heat flow across an entire assembly e.g., from air within a building to outside air; the inverse of R-Factor. Also known as U-value.

Uplift. Wind load on a building which causes a load in the upward direction.

Vapor Barrier. See Vapor retarder.

Vapor Pressure. The pressure exerted by a vapor that is in equilibrium with its solid or liquid form.

Vapor Retarder. A material that resists the transmission of water vapor.

Vent. Opening designed to convey water vapor or other gas from inside a building or a building component to the atmosphere.

Viscoelastic. Characterized by changing mechanical behavior, from nearly elastic at low temperature to plastic, like a viscous fluid, at high temperature.

Viscosity. Index of a fluid's internal resistance to flow, measures in centistokes (cSt) for bitumens. (Water has a viscosity of roughly 1 cSt, light cooking oil 100 cSt.)

Waterproofing. Treatment of a surface or structure to prevent the passage of water under hydrostatic pressure.

CANCELLED

APPENDIX D WARRANTIES

D-1 GENERAL.

Many roofing systems include a warranty or guarantee. To safe guard the interest of the client, it is necessary to have a thorough understanding of what is and is not covered by the installer or manufacturer under the warranty. Careful attention to written details of the contractor's obligations and field installation of the products will improve the viability of the roof and enhance its performance. Although warranties by themselves will not guarantee a long lasting, watertight roof, they can be an important part of the process.

Meet the requirements of Chapter 1, Warranty Requirements. In addition, a 20-year full system water-tightness warranty is recommended on all projects regardless of anticipated service life because this yields better materials, better design details, and improved construction quality. A five-year general contractor warranty is also recommended. This appendix provides additional background information on warranty options.

D-2 WARRANTY TYPES.

D-2.1 Manufacturers' Warranties.

Manufacturer's warranties are often offered as an "off the shelf" item. Most manufacturers offer several different warranties for the same products and systems based on level of installation quality.

D-2.1.1 Materials Warranty (five to 20 years).

Material warranties focus on the durability of the product installed on the roof. Labor to remove and reinstall may not be included in this warranty unless specifically required by the contract. Exclusions should be carefully reviewed since they vary widely—from reasonable exclusions such as unusual weather conditions and owner neglect to unreasonable exclusions.

D-2.1.2 Water-tightness Warranty (System Warranty) (five to 20 years)

Watertight warranties are used to obtain quality installation. Manufacturers will list requirements in the warranty necessary for the warranty to remain intact—such as regular inspections (two or more times a year). The watertight roof system warranty should include all roof penetrations and flashing (interface with all adjacent surfaces). To maintain the warranty, the roof must be installed according to manufacturer's requirements—which often specify the roof installers. When other than an approved roof installer installs features on the roof (mechanical contractors, etc.), problems may occur in obtaining watertight warranty coverage for those features. This issue should be addressed in the contract specification. Signatures on Warranty must be from the roof SYSTEM manufacturer and the Government User, not the General Contractors. This

helps to avoid issues if the general contractor goes out of business. Watertight warranties include Weathertight, Pro-Rated and Non Pro-rated. The Pro-Rated warranty functions much as a Tire or Battery warranty that reduces coverage the longer the roof is in use—do not use Pro-Rated warranties.

Full System Warrantees are single sources warranties in which all materials provided by the roof cover manufacturer are covered under the terms of the warranty. Full system warranties should be required if possible as they eliminate the 'finger pointing' if and when concerns arise. However, note that Full System Warrantees are issued jointly by the manufacturer and the roofing contractor. The manufacturer does not warrant workmanship. Should the roofing contractor go out of business there is no recourse through the manufacturer for workmanship issues.

D-2.1.3 No Dollar Limit Warranty (System Warranty) (10 to 20 years).

The best standard warranty issued in the roofing industry today is the No Dollar Limit Warranty. No Dollar Limit means there is no cap on what the manufacturer must pay to bring the roof back to a watertight condition. This warranty is issued by the manufacturer and covers both labor and materials.

It is standard in the industry for the roofing contractor to have responsibility for workmanship issues the first two years of a warranty. However, with a No Dollar Limit Warranty, if a contractor goes out of business during that time the material manufacturer automatically picks up the responsibility.

D-2.2 General Contractor's Warranties (one to five years).

Recently some government roof specifications call for a General Contractor's Watertight Warranty to add another method of ensuring a quality roof installation.

Unless stated otherwise in the Scope of Work in the RFP, all permanent new construction and replacement roofs require a Five Year General Contractor Bonded Watertightness Warranty. The scope of work in the RFP may waive the Bonding requirement, but if not specified, the Bonded 5 year watertightness warranty is required. The required wording of the warranty will be provided in the applicable UFGS.

D-2.3 Roof Installers Warranty to General Contractor (one to two years).

The government does not have a direct contractual relationship with any subcontractor, including a roof subcontractor. General Contractors will attempt to achieve the same legal protection as the government by requiring the roof subcontractor be responsible to maintain the roof. Because the roof subcontractor may go out of business, the government specification shall require the General Contractor be responsible for the required repairs.

D-3 BONDING.

Bonding may be appropriate for mission critical buildings. The signatures on the bond must be between the Bonding Company and the Government User. A bond is an insurance policy with a maximum monetary value. The holder of the bond will receive the bond value in case of default, so it is important that the government be the agency named on that bond. Bonds are typically for one or five years. Bonding may be an issue for some contractors because it reduces their bonding capacity for those five years.

D-4 WARRANTY REVIEW.

The warranty wording must be carefully reviewed during the shop drawing review.

D-5 CONTRACTOR'S WARRANTY.

The final Contractor's warranty wording must be compared to the requirements included in the contract specification.

D-5.1 Roof Manufacturer's Warranty.

The wording of the roof manufacturer's warranty must be carefully reviewed. The Roofing Materials Guide published each year by NRCA is a good source of information on what different manufacturers offer in manufacturer warranties. Key elements to review are listed below:

D-5.1.1 Qualified Installer.

Most if not all manufacturers' warranties are available ONLY if a certified contractor is used to install the material. As a quality assurance item, specify that only contractors certified to install twenty-year, no-monetary-limit full-system warranties be allowed to install the roof system.

D-5.1.2 Length of Warranty.

Verify that the length of full-system warranty matches the contract specification. Verify that the full-system warranty value is not prorated over the warranty period.

D-5.1.3 Exclusions.

Exclusions can reduce the value of the warranty to user AND prevent normal legal options to enforce standard construction rights. Some typical exclusions include the following:

D-5.1.3.1 Legal.

Note that the term "sole and exclusive remedy" often takes away other legal rights.

D-5.1.3.2 Technical.

Technical exclusions must be carefully reviewed. As an example, excluding wind coverage for commonly occurring wind speeds shall not be allowed.

D-5.2 Warranty Claim.

Review process for claiming under warranty. Verify that the warranty's procedure for creating a warranty claim is reasonable and alert the building user and all stakeholders to the procedures.

D-6 CLOSE-OUT.

Warranty information needs to be provided to the building user during the project close-out phase.

D-7 BUILDING MAINTENANCE.

Roof maintenance is a key element to maintaining a roof warranty. While contracts that include prepaid yearly inspections to comply with manufacturer's requirements are common in the private sector, they are less common for the Military. Annual inspections shall be the responsibility of the building facility support personnel and will not void warranties when not performed.

D-8 POST-CONSTRUCTION ROOF MODIFICATIONS.

User requirements may result in roof modifications. Generally this means cutting into an existing roof that is under warranty. Such modifications must be in accordance with warranty requirements in order to not void the warranty.

APPENDIX E QUALITY ASSURANCE CONSIDERATIONS

E-1 GENERAL.

The success of a roof's performance over its expected lifespan depends upon using qualified designers familiar with local conditions and engaging qualified contractors to construct the project. Quality Assurance is the determination that the designer and contractor followed established quality control guidelines.

The NRCA Manual provides excellent guidance. Quality control requirements must be clearly defined and enforced. The cost and benefits of roof installation observation by a registered roof consultant (RRC) or a registered roof observer (RRO) or a registered PE or RA that derives his or her principal income from roofing design should be considered for all Military roofing projects.

The NRCA Quality Control Guidelines are particularly well suited for reference in design-build contract requirements where BUR, MB and single-ply systems are to be constructed. The benefits of full time observation through an RRC or a registered PE or RA that derives his or her principal income from roofing design are particularly high when this type of contract is used. In addition to inspecting the construction process, the full-time inspector shall review contract documents prior to the commencement of construction.

E-2 DESIGN.

Roof system design is the purvey of RRC or a registered PE or RA that derives his or her principal income from roofing design. A qualified architect or engineer shall be employed to design and oversee the preparation of contract documents. One of the major decisions in developing a quality roofing system is the choice of roof type. Many factors will influence a designer's roof choice, and many of these factors will be regional. The critical elements are climate, wind force, resistance to ultraviolet rays, and design for local conditions. In addition to these critical elements, the experience of the local contractor will greatly affect the quality of the installation.

E-3 SPECIFICATIONS.

Once the roof system is designed, the project specifications will be developed. The UFGS must serve as the basis for the project specifications. Key elements to consider in development of the specifications are listed below:

E-3.1 Roof System.

Specify a complete roof system—not just the components—to assure clear responsibility for correction. The requirement of a full system warranty will also provide a level of enhanced coverage.

E-3.2 Maintainability.

The designer will factor into the design process the ability of the user to maintain the roof. Some roof systems require more maintenance than others. The warranties of some roofs require inspection at least two times a year.

E-3.3 Submittals.

Require submittals (shop drawings) to verify quality in the details and in components. Assure that the roof specification requires complete shop drawings.

E-3.4 Roof Manufacturer Inspection.

Consider requiring roof manufacturer's representative to inspect the roof at least three times (beginning, middle, and end) during installation. If so desired, this requirement needs to be specified in the contract documents. These types of inspections shall only be required on projects of some complexity and intricacy.

E-3.5 Warranty Selection.

Warranties shall be utilized for fully conditioned human occupied spaces. Refer to Appendix D for more information on warranties.

E-3.6 Pre-installation/Pre-construction Meeting.

Attendance at the pre-installation/pre-construction meeting is required for all key players, including the government representative, general contractor, roof contractor, and representatives from all trades whose work impinges upon the roof system: plumbing, HVAC, carpentry, masonry, steel deck erectors. The roof manufacturer's technical staff shall be present at this meeting if the project is unique, has special conditions, and/or questions in regard to various concerns exist.

E-3.7 Minimum Installer Qualifications.

Require sufficient qualifications from the installer to achieve good workmanship. Minimum installer qualifications include the following:

- Proof of at least three years of membership in a professional or trade roofing-related organization such as NRCA, RCI, a state Roofing Contractors Association or SMACNA.
- Documented five years of experience and five jobs of similar complexity, size and cost.
- Proof of certification by the manufacturer that the installer is qualified to install the roofing system specified.
- Letter from a RRC, RA or PE that they are familiar with the installer's work and the installer has demonstrated the skill and workmanship necessary to meet NRCA, SMACNA and industry standards.

E-4 FIELD INSPECTION(S)/CQM.

E-4.1 Installation.

The field inspector shall verify that roof is installed according to shop drawing details. The inspector shall look for complex situations not previously identified and discuss with QC personnel and the on-site roof installer foreman. He must also spot check critical areas for quality watertight construction.

The field inspector shall keep a daily journal of roofing activities, weather conditions, number of workers, visitors to the job site and accidents or incidents. In addition, daily photos of the work and worksite shall be taken. Many things are hidden in roofing. Photos take the guesswork out of reconstructing what actually took place and can benefit the contractor as well as the owner. All photos and daily journal shall be part of the close out documents.

E-4.2 Leaks.

If leaks exist before closeout, do not accept the roof per the contract or pay the General Contractor in full. Test and remove defective material/installation to locate problem and repair. Consult a roof consultant with an RRC or a registered PE or RA that derives his or her principal income from roofing design if local expertise is not adequate.

E-5 CLOSE OUT OF CONTRACT.

Warranties are the legal means of users to get a new roof repaired. The facility manager shall be provided a copy of the warranty and be familiar with all requirements to keep the warranty in force.

This Page Intentionally Left Blank

CANCELLED

APPENDIX F OTHER RESOURCES

GOVERNMENT PUBLICATIONS:

- Air Force Instruction 32-1051, *Roof Systems Management*, 1994, Air Force Civil Engineer Service Center (AFCEA), Tyndall Air Force Base, 139 Barnes Drive, Florida, 32403, www.wbdg.org/ccb/AF/AFI/afi_32_1051.pdf
- APA Form N335, *Guidelines for Proper Installation for APA Rated Sheathing for Roof Applications, Residential and Commercial Manual, Design/Construction Guide*, APA-The Engineered Wood Association, 7011 South 19th Street, Tacoma, WA, 98411-0700, www.apawood.org
- FM-93/11, *ROOFER: Membrane and Flashing Condition Indexes for Single-Ply Membrane Roofs - Inspection and Distress Manual*, 1993, Construction Engineering Research Laboratory (CERL), 5285 Port Royal Road, Springfield VA, 22161 (order from NTIS: www.dtic.mil)
- M87-13, *Membrane and Flashing Condition Indexes for BURs: Inspection and Distress Manual*, Vol II, 1987, Construction Engineering Research Laboratory (CERL), 5285 Port Royal Road, Springfield VA, 22161 (order from NTIS: www.dtic.mil)
- M-90/04, *ROOFER: An Engineered Management System for Bituminous Built-up Roofs*, 1989, Construction Engineering Research Laboratory (CERL), 5285 Port Royal Road, Springfield VA, 22161 (order from NTIS: www.dtic.mil)
- MP 2489, *Vapor Retarders for Membrane Roofing Systems*, 1989, Cold Regions Research & Engineering Laboratory (CRREL), 72 Lyme Road, Hanover, NH, 03755, www.crrel.usace.army.mil/library/technicalpublications.html
- MP 2866, *New Wetting Curves for Common Roof Insulations*, 1991, Cold Regions Research & Engineering Laboratory (CRREL), 72 Lyme Road, Hanover, NH, 03755, www.crrel.usace.army.mil/library/technicalpublications.html
- MP 3233, *Standing Seam Metal Roofing Systems in Cold Regions*, 1993, Cold Regions Research & Engineering Laboratory (CRREL), 72 Lyme Road, Hanover, NH, 03755, www.crrel.usace.army.mil/library/technicalpublications.html
- MP 3443, *General Considerations for Roofs*, 1994, Cold Regions Research & Engineering Laboratory (CRREL), 72 Lyme Road, Hanover, NH, 03755, www.crrel.usace.army.mil/library/technicalpublications.html
- MP 3527, *Ventilating Attics to Minimize Icings at Eaves*, 1994, Cold Regions Research & Engineering Laboratory (CRREL), 72 Lyme Road, Hanover, NH, 03755, www.crrel.usace.army.mil/library/technicalpublications.html

NIST Special Publication 811, *Guide for the Use of International System of Units (SI)*, 1995, National Institute for Standards and Technology (NIST), Structures and Materials Division/Center for Building Technology, Gaithersburg, MD, 20899 (order from NTIS: www.dtic.mil)

ORNL-6520, *Decision Guide for Roof Slope Selection*, 1988, Air Force Civil Engineer Service Center (AFCEA), Tyndall Air Force Base, 139 Barnes Drive, Tyndall AFB, Florida, 32403, www.afcesa.af.mil

TR 99/100, *ROOFER: Steep Roofing Inventory Procedures and Inspection and Distress Manual for Asphalt Single Roofs*, 1999, Construction Engineering Research Laboratory (CERL), 5285 Port Royal Road, Springfield VA, 22161 (order from NTIS: www.dtic.mil)

UFC 3-330-02A, *Commentary On Roofing Systems*, Unified Facilities Criteria Program, dod.wbdg.org

NON-GOVERNMENT PUBLICATIONS:

ARMA Form 207-RR-85, *Plain Facts About Buckled Shingles*, Asphalt Roofing Manufacturer Association, 750 National Press Building, 529 14th Street, NW, Washington, DC 20045, www.asphaltroofing.org/

ARMA Form 210-RR-71, *Color Shading of Asphalt Shingle Roofs*, Asphalt Roofing Manufacturer Association, 750 National Press Building, 529 14th Street, NW, Washington, DC 20045, www.asphaltroofing.org/

Building Materials Directory, Underwriters Laboratories (UL), 333 Pfingsten Road, Northbrook, IL, 60062, www.ul.com

Clay Roof Tile Manual, Western States Roofing Contractors Association (WSRCA), 465 Fairchild Drive, Mountain View, CA 94043, www.wsrca.com/

Commercial Roofing Materials Guide, National Roofing Contractors Association (NRCA), 10255 West Higgins Road, Suite 600, Rosemont, IL, 60018-5607, www.nrca.net

Concrete and Clay Roof Tile Installation Manual, Tile Roofing Institute, 35 East Wacker Drive, Suite 850, Chicago, IL 60601-2106, www.tilerroofing.org

Concrete and Clay Tile Roof Design Criteria Manual for Cold, Snowy Regions, Tile Roofing Institute, 35 East Wacker Drive, Suite 850, Chicago, IL 60601-2106, www.tilerroofing.org

Copper In Architecture, Copper Development Association, 260 Madison Avenue, New York, NY, 10016, www.copper.org

Florida Building Code, Florida Department of Community Affairs, 2555 Shumard Oak Boulevard, Tallahassee, FL, 32399-2100, www.floridabuilding.org

Manual of Construction with Steel Deck, Steel Deck Institute (SDI), P.O. Box 25, Fox River Grove, IL, 60021, www.sdi.org

Manual of Inspection and Maintenance of Built-Up and Modified Bitumen Roof Systems, National Roofing Contractors Association (NRCA), 10255 West Higgins Road, Suite 600, Rosemont, IL, 60018-5607, www.nrca.net

NRCA/ARMA Manual of Roof Maintenance and Repair, National Roofing Contractors Association (NRCA), 10255 West Higgins Road, Suite 600, Rosemont, IL, 60018-5607, www.nrca.net

Manual for Inspection and Maintenance of Sprayed Polyurethane Foam-based Roof Systems, National Roofing Contractors Association (NRCA), 10255 West Higgins Road, Suite 600, Rosemont, IL, 60018-5607, www.nrca.net

Quality Control Guidelines for Built-Up Roofing, National Roofing Contractors Association (NRCA), 10255 West Higgins Road, Suite 600, Rosemont, IL, 60018-5607, www.nrca.net

Quality Control Guidelines for Application of Polymer Modified Bitumen Roofing Systems, National Roofing Contractors Association (NRCA), 10255 West Higgins Road, Suite 600, Rosemont, IL, 60018-5607, www.nrca.net

Quality Control Guidelines for the Application of Thermoset Single-ply Roof Membranes, National Roofing Contractors Association (NRCA), 10255 West Higgins Road, Suite 600, Rosemont, IL, 60018-5607, www.nrca.net

Repair Manual for Low-Slope Roof Systems, National Roofing Contractors Association (NRCA), 10255 West Higgins Road, Suite 600, Rosemont, IL, 60018-5607, www.nrca.net

Repair Methods for Re-Attaching EPDM Membrane and Flashing Experiencing Shrinkage, National Roofing Contractors Association (NRCA), 10255 West Higgins Road, Suite 600, Rosemont, IL, 60018-5607, www.nrca.net

Roofing Materials and Systems Directory, Underwriters Laboratories (UL), 333 Pfiingsten Road, Northbrook, IL, 60062, www.ul.org

SPRI/NRCA Manual of Roof Inspection, Maintenance and Emergency Repair for Existing Single-ply Roofing Systems, National Roofing Contractors Association (NRCA), 10255 West Higgins Road, Suite 600, Rosemont, IL, 60018-5607, www.nrca.net

Standard Practice in Sheet Metal Work, Sheet Metal and Air Conditioning Contractors
National Association, 4201 Lafayette Center Drive, Chantilly, VA, 22021,
www.smachna.org

CANCELLED