

# TRI-SERVICE PAVEMENTS WORKING GROUP (TSPWG) MANUAL

## EXPEDIENT TRIM PAD ANCHORING SYSTEMS



APPROVED FOR PUBLIC RELEASE; DISTRIBUTION UNLIMITED

**TRI-SERVICE PAVEMENTS WORKING GROUP MANUAL (TSPWG M)**

**EXPEDIENT TRIM PAD ANCHORING SYSTEMS**

Any copyrighted material included in this TSPWG Manual is identified at its point of use. Use of the copyrighted material apart from this TSPWG Manual must have the permission of the copyright holder.

Indicate the preparing activity beside the Service responsible for preparing the document.

U.S. ARMY CORPS OF ENGINEERS

NAVAL FACILITIES ENGINEERING COMMAND

AIR FORCE CIVIL ENGINEER CENTER (Preparing Activity)

Record of Changes (changes are indicated by \1\ ... /1/)

<b>Change No.</b>	<b>Date</b>	<b>Location</b>

## **FOREWORD**

This Tri-Service Pavements Working Group Manual supplements guidance found in other Unified Facilities Criteria, Unified Facility Guide Specifications, Defense Logistics Agency Specifications, and Service specific publications.. All construction outside of the United States is also governed by Status of Forces Agreements (SOFA), Host Nation Funded Construction Agreements (HNFA), and in some instances, Bilateral Infrastructure Agreements (BIA.) Therefore, the acquisition team must ensure compliance with the most stringent of the TSPWG Manual, the SOFA, the HNFA, and the BIA, as applicable. This manual provides guidance on the construction of expedient trim pad anchors. The information in this TSPWG Manual are referenced in technical publications found on the Whole Building Design Guide. It is not intended to take the place of service specific doctrine, technical orders (TOs), field manuals, technical manuals, handbooks, Tactic Techniques or Procedures (TTPs) or contract specifications but should be used along with these to help ensure pavements meet mission requirements.

TSPWG Manuals are living documents and will be periodically reviewed, updated, and made available to users as part of the Services' responsibility for providing technical criteria for military construction, maintenance, repair, or operations. Headquarters, U.S. Army Corps of Engineers (HQUSACE), Naval Facilities Engineering Command (NAVFAC), and Air Force Civil Engineer Center (AFCEC) are responsible for administration of this document. Technical content of this TSPWG Manual is the responsibility of the Tri-Service Pavements Working Group (TSPWG). Defense agencies should contact the preparing activity for document interpretation. Send recommended changes with supporting rationale to the respective service TSPWG member.

TSPWG Manuals are effective upon issuance and are distributed only in electronic media from the following source:

- Whole Building Design Guide web site <http://dod.wbdg.org/>.

Hard copies of TSPWG Manuals printed from electronic media should be checked against the current electronic version prior to use to ensure that they are current.

**TRI-SERVICE PAVEMENTS WORKING GROUP MANUAL (TSPWG M)  
NEW SUMMARY SHEET**

**Document:** TSPWG Manual 3-260-01.06-04, Expedient Trim Pad Anchoring Systems

**Superseding:** USAF ETL 06-4 Expedient Trim Pad Anchoring Systems

**Description:** Provides guidance for constructing anchoring systems for an expedient trim pad.

**Reasons for Document:**

- DOD engineers need to be able to construct expedient trim pads.

**Impact:** There is no cost impact. The following benefits should be realized.

- Supplemental information on the construction of expedient trim pad anchoring systems will be available to all services.
- Maintenance and/or upgrading of this supplemental information will include inputs from all services.

**Unification Issues**

None.

**Note:** The use of the name or mark of any specific manufacturer, commercial product, commodity, or service in this publication does not imply endorsement by the Department of Defense (DOD).

**TABLE OF CONTENTS**

**CHAPTER 1 INTRODUCTION ..... 1**

**1-1 BACKGROUND. .... 1**

**1-2 PURPOSE AND SCOPE. .... 1**

**1-3 APPLICABILITY..... 1**

**1-4 GENERAL BUILDING REQUIREMENTS. .... 1**

**1-5 REFERENCES. .... 1**

**1-6 GLOSSARY..... 1**

**CHAPTER 2 TRIM PAD OPTIONS ..... 3**

**2-1 INTRODUCTION. .... 3**

**APPENDIX A REFERENCES..... 5**

**APPENDIX B BEST PRACTICES ..... 7**

**B-1 ARCHIVED USAF ETL 06-04. .... 7**

**APPENDIX C GLOSSARY ..... 25**

**C-1 ACRONYMS..... 25**

**C-2 DEFINITION OF TERMS ..... 26**

**FIGURES**

No table of figures.

**TABLES**

No table of figures.

*This Page Intentionally Left Blank*

## CHAPTER 1 INTRODUCTION

### 1-1 BACKGROUND.

Trim pad anchors are often required at locations where no trim pad anchor exists that is known to be rated for the aircraft in need of testing. An expedient trim pad anchor can be constructed and used until a permanent trim pad is constructed.

### 1-2 PURPOSE AND SCOPE.

This manual provides a description of options to construct expedient trim pads that were previously tested.

### 1-3 APPLICABILITY.

This manual applies to any DoD engineering units that require an expedient trim pad. .

### 1-4 GENERAL BUILDING REQUIREMENTS.

Comply with UFC 1-200-01, *DoD Building Code (General Building Requirements)*. UFC 1-200-01 provides applicability of model building codes and government unique criteria for typical design disciplines and building systems, as well as for accessibility, antiterrorism, security, high performance and sustainability requirements, and safety. Use this UFC in addition to UFC 1-200-01 and the UFCs and government criteria referenced therein.

### 1-5 REFERENCES.

Appendix A contains a list of references used in this document. The publication date of the code or standard is not included in this document. Unless otherwise specified, the most recent edition of the referenced publication applies.

### 1-6 GLOSSARY.

Appendix C contains acronyms, abbreviations, and terms.

*This Page Intentionally Left Blank*



## CHAPTER 2 TRIM PAD OPTIONS

### 2-1 INTRODUCTION.

Appendix B contains options for the construction of expedient trim pad anchors.

*This Page Intentionally Left Blank*

## APPENDIX A REFERENCES

### UNIFIED FACILITIES CRITERIA

[http://www.wbdg.org/ccb/browse\\_cat.php?o=29&c=4](http://www.wbdg.org/ccb/browse_cat.php?o=29&c=4)

UFC 1-200-01, *DoD Building Code (General Building Requirements)*

UFC 3-260-01, *Airfield And Heliport Planning And Design*

*This Page Intentionally Left Blank*

**APPENDIX B BEST PRACTICES**

**B-1           ARCHIVED USAF ETL 06-04.**

A copy of archived USAF ETL 06-04 Expedient Trim Pad Anchoring Systems is appended in the following pages.



**DEPARTMENT OF THE AIR FORCE**  
HEADQUARTERS AIR FORCE CIVIL ENGINEER SUPPORT AGENCY

8 MAY 2006

FROM: HQ AFCESA/CES  
139 Barnes Drive, Suite 1  
Tyndall AFB FL 32403-5319

SUBJECT: **Engineering Technical Letter (ETL) 06-4: Expedient Trim Pad Anchoring Systems**

**1. Purpose:** This ETL provides non-mandatory guidance for constructing anchoring systems for an expedient trim pad. The procedures in paragraphs 6 and 7 may be used when the construction of a permanent trim pad is not practical. This ETL supersedes ETL 97-4, *Expedient Trim Pad Anchoring*.

**Note:** The use of the name or mark of any specific manufacturer, commercial product, commodity, or service in this ETL does not imply endorsement by the Air Force.

**2. Summary of Revisions:** This ETL is substantially revised and must be completely reviewed.

**3. Application:** All Air Force organizations with pavement construction responsibility.

**3.1. Authority:**

- Air Force Policy Directive (AFPD) 32-10, *Installations and Facilities*.

**3.2. Effective Date:** Immediately.

**3.3. Intended Users:**

- Air Force base civil engineers, RED HORSE squadrons, and other units responsible for the planning, design, construction, maintenance, and repair of trim pads.
- U.S. Army Corps of Engineers (USACE) and Navy offices responsible for Air Force design and construction.

**3.4. Coordination:** Major command (MAJCOM) pavements engineer.

**4. Referenced Publications:**

- AFPD 32-10, *Installations and Facilities*, available at <http://www.e-publishing.af.mil/afpubs.asp>
- Wright Laboratories Report, *Expedient Trim Pad Anchor Test*, 4 April 1996.  
**Note:** This report was prepared for the 823rd RED HORSE Squadron to determine load-carrying capacity of a group of 12 earth anchors used in the Mobile Aircraft Arresting System (MAAS). The tests, conducted at Tyndall Air

**APPROVED FOR PUBLIC RELEASE: DISTRIBUTION UNLIMITED**

Force Base, Florida, concluded that a 12-stake anchor group constructed in similar soil conditions should support a maximum load of 177.9 kilonewtons (40,000 pounds). Guidance in paragraph 6 of this ETL was extracted from this report.

- Technical Order (T.O.) 35E8-2-10-1, *Operation and Maintenance Instructions – Arresting Systems, Aircraft, Mobile, Model No. AM32A-96*
- ETL 00-2, *Inspection and Testing of Trim Pad Anchoring Systems*, available at <http://www.afcesa.af.mil/library/etl.asp?Category=Engineering%20Technical%20Letters>
- ETL 01-10, *Design and Construction of High-Capacity Trim Pad Anchoring Systems*, available at <http://www.afcesa.af.mil/library/etl.asp?Category=Engineering%20Technical%20Letters>

#### 5. Acronyms:

AFB	- Air Force Base
CBR	- California Bearing Ratio
ETL	- Engineering Technical Letter
ft	- foot
in	- inch
KN	- kilonewton
lb	- pound
MAAS	- mobile aircraft arresting system
MAJCOM	- major command
m	- meter
mm	- millimeter
T.O.	- Technical Order

**6. Procedure for Earth Anchor System.** This expedient anchor system may be used for a wide spectrum of site conditions. Tests conducted at Tyndall AFB concluded that an anchor constructed in similar soil conditions should be able to support a maximum loading of approximately 177.9 kilonewtons (40,000 pounds). Installation procedures are as follows:

**6.1. Step 1.** Select a tentative location for the expedient trim pad, with a 12-stake anchor group to be installed at both restraining cable ends. See Figure 1 for a typical expedient trim pad location/layout schematic and Figure 2 for a detailed schematic of a 12-stake anchor group.

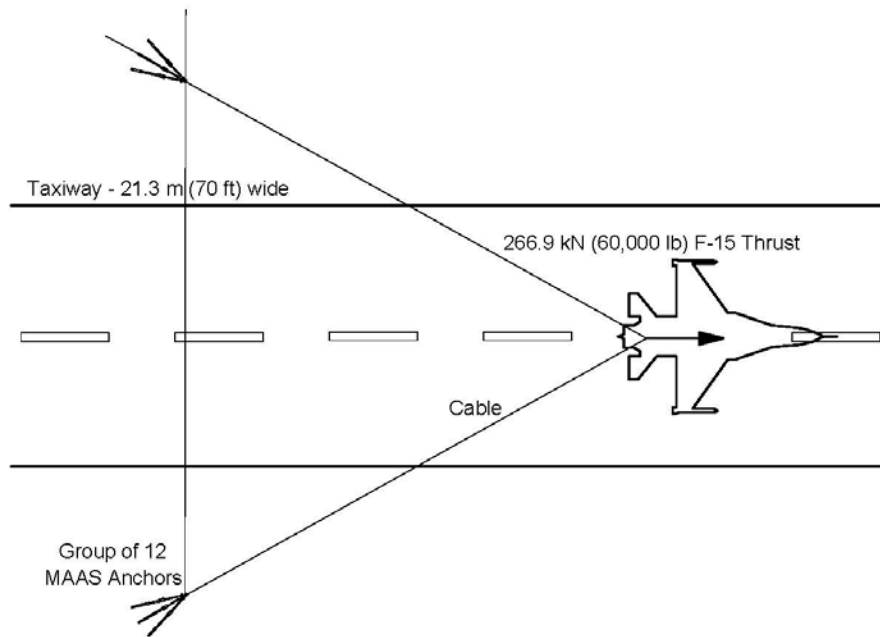
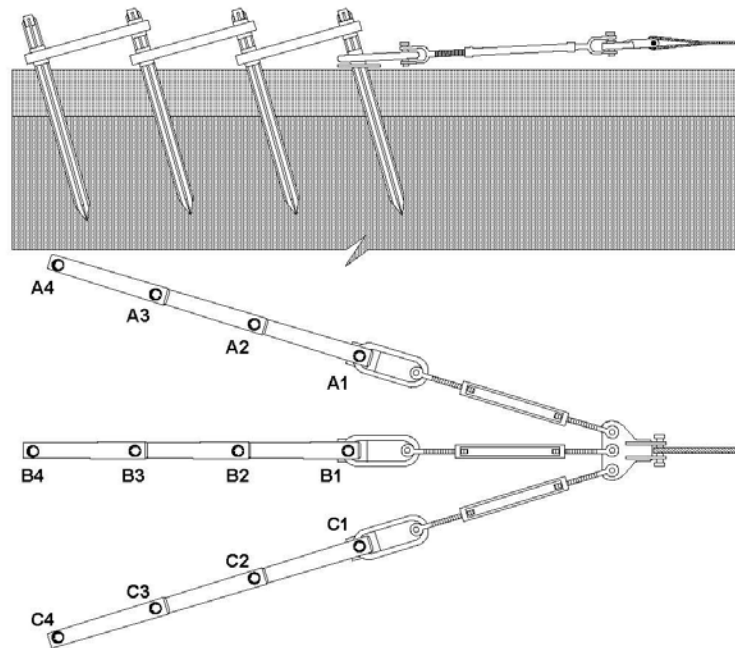

Figure 1. Expedient Trim Pad Schematic





**Figure 2. 12-Stake Anchor Group Schematic**

**6.2. Step 2.** Perform three dynamic cone penetrometer (DCP) tests, with test points spaced 0.6 to 0.9 meter (2 to 3 feet) apart, at each cable end anchoring location to determine the California Bearing Ratio (CBR) profile of the soil. Compare the CBR profiles of the actual site to the profiles developed by Wright Laboratories for the Tyndall AFB test location (Figure 3). If the average CBR profile of the selected site is about the same or consistently higher, then the pullout capacity of the anchor group should be 177.9 kilonewtons (40,000 pounds) or higher. If a lower CBR profile is measured, the anchor group capacity will be less than 177.9 kilonewtons (40,000 pounds). In this case, either use the DCP to find firmer soil or increase the number of stakes in each anchor group. Figure 4 shows a schematic for a possible 16-stake anchor group.

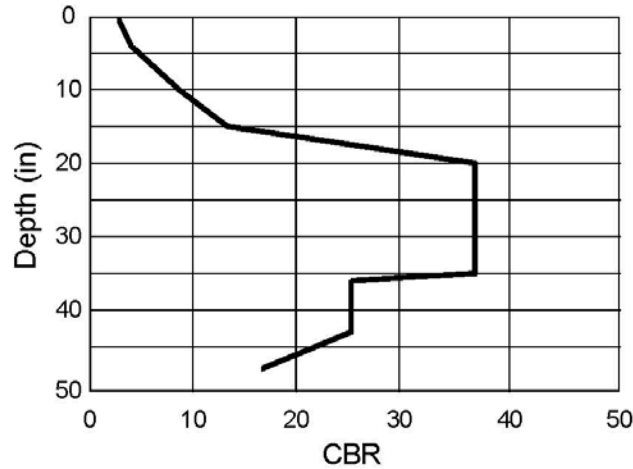

Figure 3. CBR Profile for Test Locations

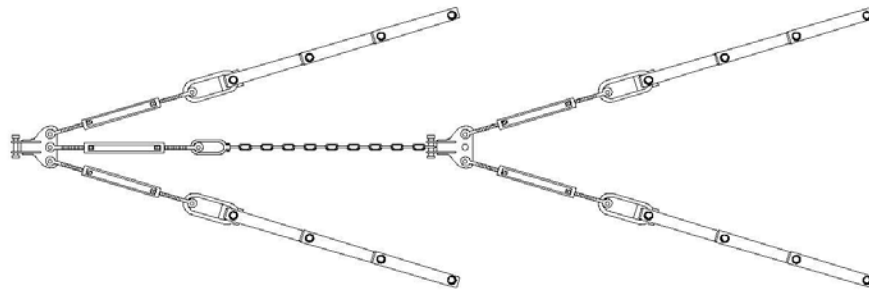

Figure 4. 16-Stake Anchor Group Schematic

6.3. Step 3. Line up the center line of the stake group with the anticipated direction of restraining cable pull when the aircraft is secured to the cable.

**Note:** The cable length and the distance between anchor groups both have an effect on the resultant anchor load (see Figure 5). For the best results, minimize the distance between the anchor groups and maximize the cable length. For example, assume an F-15 with a thrust of 266.9 kilonewtons (60,000 pounds). The horizontal component of the thrust in the restraining cable transferred to each anchor group would be 133.4 kilonewtons (30,000 pounds). Referring to Figure 5 and the accompanying table, the total thrust to be resisted by each anchor group, for a spacing of 18.3 meters (60 feet) and a 91.4-meter (300-foot) long cable, would be 134.8 kilonewtons (30,300 pounds). However, for a spacing of 30.5 meters (100

feet) and a 45.7-meter (150-foot) long cable, the total thrust to be resisted by each anchor group would be 180.2 kilonewtons (40,500 pounds).

**Table 1. Effect of Cable Length on Required Anchor Capacity**

Distance Between Anchor Groups meters (feet)	Cable Length meters (feet)	Multiplier (Horizontal Component of Thrust)	Total Thrust per Anchor Group kilonewtons (pounds)
18.3 (60)	91.4 (300)	1.01	134.8 (30,300)
30.5 (100)	91.4 (300)	1.06	141.5 (31,800)
18.3 (60)	45.7 (150)	1.09	145.5 (32,700)
30.5 (100)	45.7 (150)	1.35	180.2 (40,500)

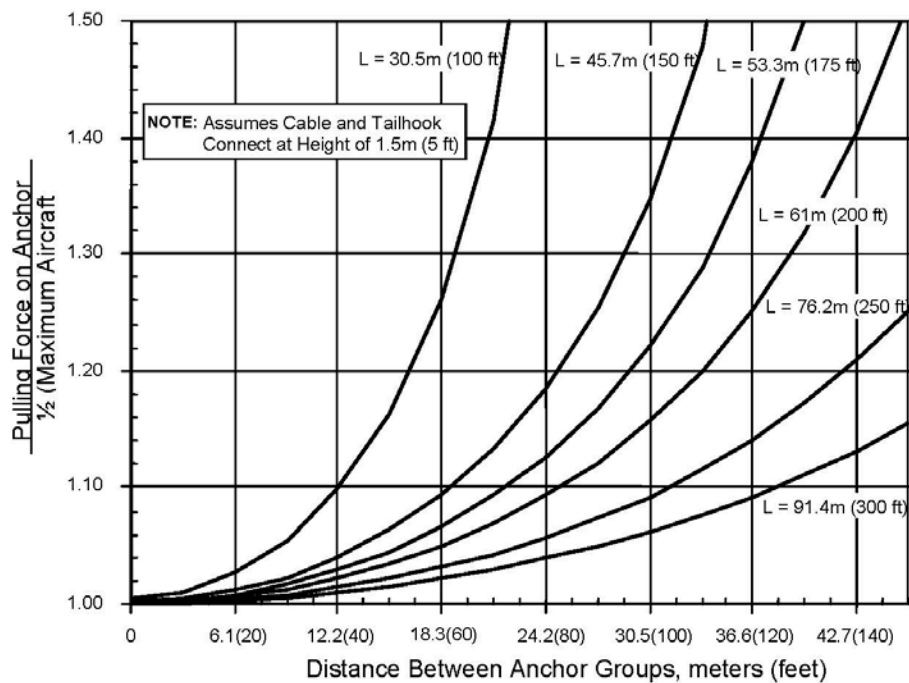

**Figure 5. Effect of Cable Length on Required Anchor Capacity**

**Caution:** Be sure to observe the load limits of the shackle, clevis, or other fittings used to connect the restraining cable to the triple turnbuckle fitting. A fitting marked "WLL 10 TON" has a working load limit of 89.0 kilonewtons (20,000 pounds)—not enough for the expected 133.4+ kilonewtons (30,000+ pounds) of load transferred from the cable to the anchor group.

**6.4.** Step 4. Follow standard MAAS procedures for soil installation of "KM" stake lines as stated in T.O. 35E8-2-10-1, paragraph 3-1.5.

**6.5.** Step 5. With all stakes in place, adjust the turnbuckles so the triple turnbuckle fitting lines up with the center row of stakes and the expected position of the restraining cable at maximum thrust. If possible, apply light tension to the cable and make any additional adjustments to distribute the pulling load as evenly as possible among the three anchor stake lines.

**6.6.** Step 6. Install a string line (Figure 6) across the front of the anchor group. Use the string line as a reference to monitor movements of the front anchor stakes during the mission. The string line need not remain in place during run-up operations, but reference points should be marked on the stakes so consistent measurements can be made. Arrange the reference stakes and string line so the movement of the front stakes at the ground surface can be easily measured.

**6.7.** Step 7. Monitor the performance of each anchor group for at least the first five run-up operations. Ensure personnel stay clear of the cable and anchors during engine run-up. Between each of these initial operations, check the lateral movement of the front anchor set at the ground surface by measuring off the string line. Use the following criteria for pavement front anchor lateral displacement as a rough guide to judge the performance of the anchor group:

- Less than 25 mm (1 in) ..... Adequate (condition GREEN)
- 25 to 51 mm (1 to 2 in)..... Degraded (condition AMBER)
- Greater than 51 mm (2 in)..... Unsatisfactory (condition RED)

**6.8.** Step 8. After the initial operations, check each anchor group after approximately every 20 operations. Inspect the overall anchor stake movements and use the string line as a reference to measure the front stake displacement.

**6.9.** Step 9. If more than 12 anchor stakes are needed for each anchor group, do not add more to the rear of each 4-stake line. (The front anchor in a longer line of stakes will not be able to transmit the cumulative anchoring force to the turnbuckle without failing in bending.) Use an alternate arrangement of 4-anchor lines, such as shown in Figure 4 (copied from Section 8, Figure 8-6 of T.O. 35E8-2-10-1).

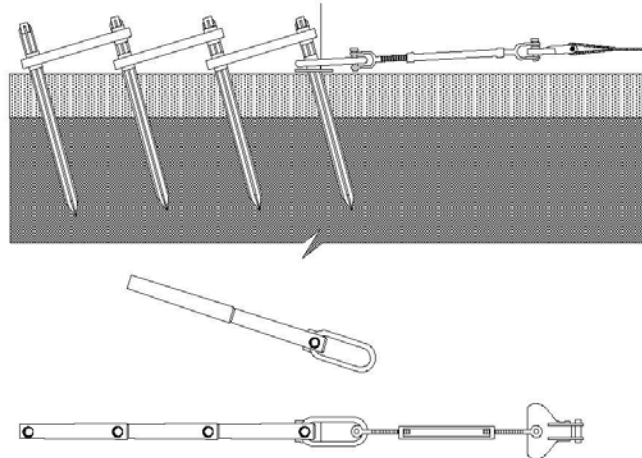

**Figure 6. Reference Line for Monitoring Anchors**

**7. Procedure for Steel Plate and Rod System.** This expedient anchor system may be used when sited in a sound concrete slab with a thickness of at least 305 millimeters (12 inches). Tests conducted at Tyndall AFB concluded that this type of anchor should be able to support a maximum loading of approximately 311.4 kilonewtons (70,000 pounds). Installation procedures are as follows:

**7.1. Step 1.** Select a tentative location for the expedient trim pad. The chosen concrete slab, as well as the immediately adjacent slabs, should all be in good condition. The anchor hole should be sited away from the edge of the slab, as close to the center of the slab as possible, to maintain slab integrity (see Figure 7). Once the hole location has been selected, use a tape measure and mark the spot with a 152-millimeter (6-inch) diameter circle, using a marker or spray paint.

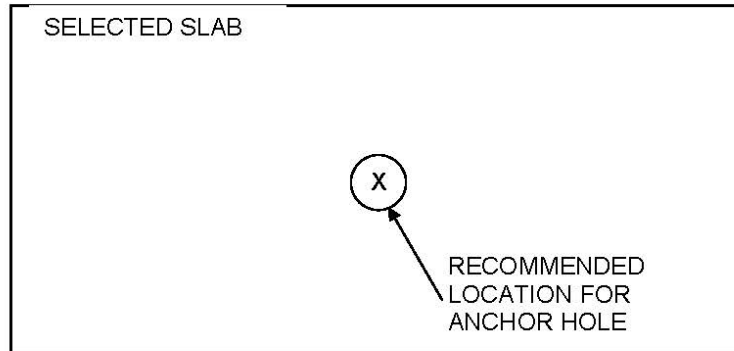

Figure 7. Anchor Hole Location

7.2. Step 2. Plug a hammer drill into a generator and begin drilling around the perimeter of the marked anchor hole location using a hammer drill equipped with a 25.4-millimeter (1-inch) diameter 457-millimeter (18-inch) long drill bit. An extension cord is recommended to allow for a greater range of movement. Drill a series of holes, leaving approximately 3.2 millimeters (0.125 inch) between each hole (see Figure 8). The holes may begin to merge during the drilling process. If available, use a vacuum and push broom to remove excess cement dust from the drilled holes and surrounding pavement. This is necessary to keep from packing the cement dust into the holes, which could cause the drill bit to “catch” along the sides of the hole, leading to the bit getting stuck and damaging the equipment.

**Note:** Depending upon the size of the generator, the drill and vacuum may not be able to be operated at the same time.



Figure 8. Drilling Anchor Hole Perimeter

**7.3.** Step 3. Use a hammer drill and a 250-millimeter (9.8-inch) long chisel bit to chisel through concrete remaining in the anchor hole. Begin chiseling the webbing areas between the holes drilled in Step 2, then work towards the center of the hole (see Figure 9). Again, if available, use a vacuum and push broom to remove excess material from the work area. If a vacuum is not available, it will be necessary to remove pieces of concrete by hand. As the depth of the hole increases, it may be necessary to use some other means to remove loose material. In the anchor development study, vacuum attachments were used in order to remove the loose material. The use of a core rig (if available) with a 152-millimeter (6-inch) diameter core barrel will expedite the process above.



**Figure 9. Chiseling Anchor Hole**

**7.4.** Step 4. Once the concrete layer has been completely drilled through, if available, use a gas-powered auger to excavate the underlying soil down to a depth of 1.2 meters (4 feet). If an auger is not available, it will be necessary to excavate the soil using a 1.5-meter (5-foot) long posthole digger. It may be necessary to use a pry bar to finish clearing the hole to the desired depth. If so, be sure to use a vacuum to remove any soil that has been loosened. It is suggested that a 1.5-meter (5-foot) long pry bar be used to allow for the proper hole depth to be established.

**7.5.** Step 5. Next, it will be necessary to weld the anchor post to the anchor plate. Using a forklift, place the anchor plate upside down on dunnage, ensuring that the hole for the anchor post is directly over the dunnage. Lower the anchor post into the hole so that the post rests on the dunnage. At this point, the top of the anchor post will be flush with the top of the anchor plate when turned right-side up. Weld the anchor post in place with a single full bead around the post's perimeter. Turn the anchor assembly on its side and fully weld the beveled area around the post. When

complete, the post should be welded solidly to the plate. High-quality full-penetration welds are necessary to ensure the structural integrity of the anchor.



**Figure 10. Welding Anchor Post to Anchor Plate**

**7.6.** Step 6. Use a forklift fitted with a chain and coil assembly to lower the anchor into the hole (see Figure 11). Once in the ground, it may be necessary to maneuver the anchor into the final desired position by bumping the corners of the anchor plate with the forks of the forklift until the plate is properly aligned.

**BE EXTREMELY CAREFUL WHEN MOVING THE ANCHOR.** The anchor weighs approximately 408 kilograms (900 pounds) and could cause serious injury if not cautious.



**Figure 11. Lowering the Expedient Anchor Plate into the Hole**



**7.7. Step 7.** Using the hammer drill and the drill bit, drill 25.4-millimeter (1-inch) diameter bolt holes through each of the bolt hole openings in the anchor plate.

**7.8. Step 8.** Insert 228-millimeter (9-inch) long by 25.4-millimeter (1-inch) diameter bolts, fitted with a flat washer and two nuts, into each of the fifteen bolt holes that were drilled in Step 7 (see Figure 12). If necessary, use a sledge hammer to hammer the bolts completely into the holes. Once in place, remove the top nut, either by hand or with a 38-millimeter (1.5-inch) box end wrench. Tighten the remaining nuts around the bolts using both a box end wrench and an electric impact wrench. These bolts provide stability to the anchor plate during the process of grouting around the anchor pole and provide a portion of the system's overall anchoring resistance during trim pad use.



**Figure 12. Anchor Plate with Bolts, Nuts and Washers in Place**

**7.9. Step 9.**

**7.9.1.** Begin mixing the Pavemend solution. The mixture should be made using 3.78 liters (1 gallon) of water for every 20.4 kilograms (45 pounds) (one bucket) of material. Insert a mixing tool attachment on a variable-speed drill into the Pavemend and begin stirring in the water. Mix the solution for a minimum of two and a half minutes. Each bucket of Pavemend will produce approximately 0.0136 cubic meter (0.48 cubic foot) of solution. Given the specified dimensions of both the hole and the anchor pole, this should mean that one bucket of material will be needed. However, it is recommended that at least six buckets of Pavemend be onsite. This is due to the fact that there will be discrepancies in the actual dimensions of the hole that is drilled; the hole could turn out to be either too deep or too wide once the concrete layer has been breached.

**Note:** To prevent premature curing, mix only half-buckets of Pavemend at a time.

**7.9.2.** Insert funnels into the two pour hole openings at the front of the anchor plate (see Figure 13). These will be used to pour the mixed Pavemend solution into the holes to stabilize the movement of the anchor plate.

**Note:** Make sure the time between mixing and pouring is minimal. The Pavemend solution will begin to set immediately and will be solid within 15 minutes.

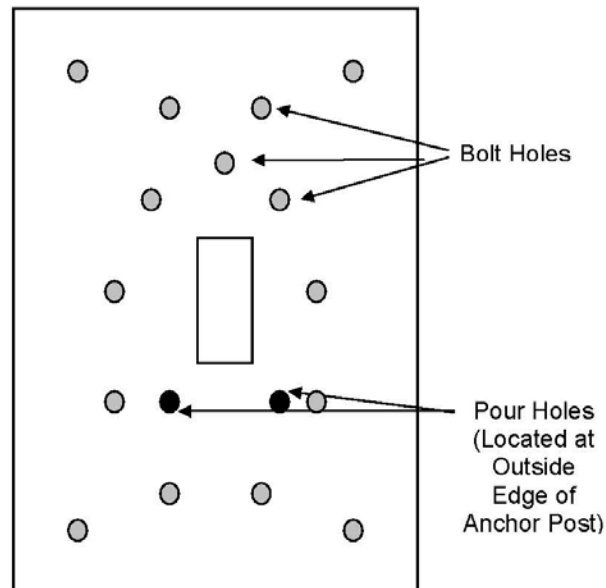

**Figure 13. Top View of Anchor Test Plate with Bolt and Pour Holes  
(See Attachment 1 for Detailed Drawings)**

**7.10.** Step 10. Place the mixing tool attachment of the variable-speed drill in water and run for approximately one minute or until all Pavemend material has been removed. It may be necessary to hand-wash the upper end of the mixing tool to completely clean it.

**7.11.** Step 11. Use the push broom to clean up any excess cement dust and rock. Allow the anchor assembly to cure for four hours before applying any load (see Figure 14).



Figure 14. Completed Anchor Plate

**8. Point of Contact.** Recommendations for improvements to this ETL are encouraged and should be furnished to the Pavements Engineer, HQ AFCESA/CESC, 139 Barnes Drive, Suite 1, Tyndall AFB, FL 32408-5319, DSN 523-6334, commercial (850) 283-6334, e-mail [AFCESAReachbackCenter@tyndall.af.mil](mailto:AFCESAReachbackCenter@tyndall.af.mil)

LESLIE C. MARTIN, Colonel, USAF  
Director of Technical Support

- 2 Atchs  
1. Expedient Anchor Plate and Rod Drawings  
2. Distribution List

**EXPEDIENT ANCHOR PLATE AND POST DRAWINGS**

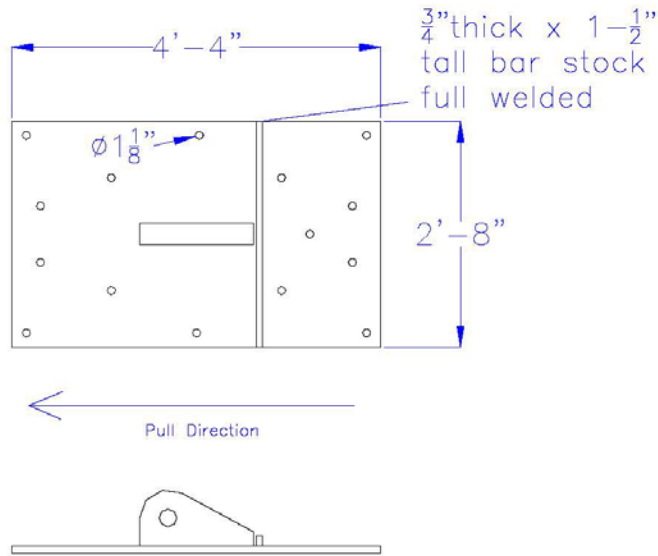

**Figure A1.1. Expedient Anchor Plate Plan and Elevation Views  
(Steel Anchor Post and Pour Holes Not Shown)**

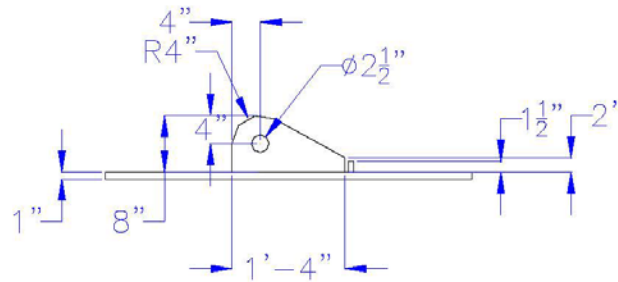

**Figure A1.2. Expedient Anchor Plate Elevation View with Dimensions  
(Steel Anchor Post Not Shown)**

Atch 1  
(1 of 2)

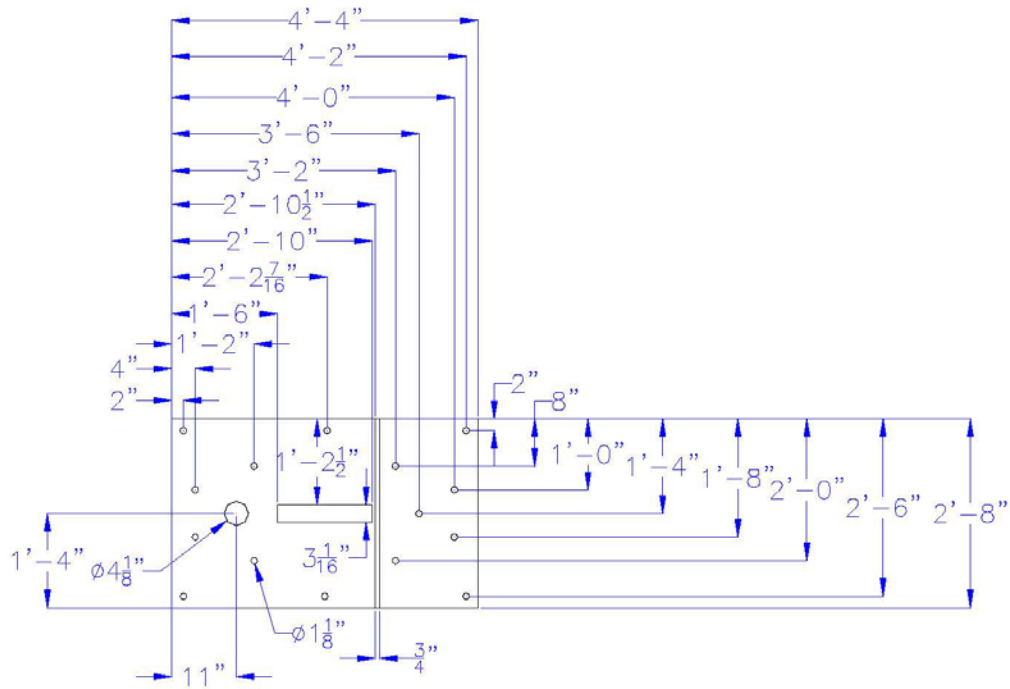

Figure A1.3. Expedient Anchor Plate Plan View with Dimensions for Bolt and Steel Anchor Post Holes (Pour Holes Not Shown)

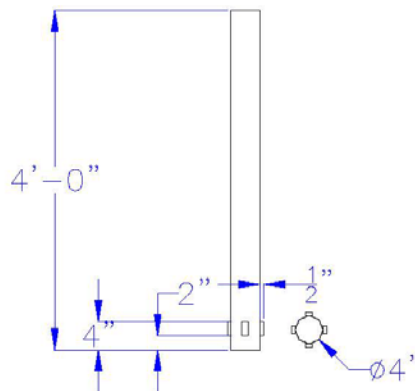

Figure A1.4. Expedient Anchor Plate Steel Anchor Post

Atch 1  
(2 of 2)

**DISTRIBUTION LIST**

DEPARTMENT OF DEFENSE

Defense Commissary Agency (1) Design and Construction Division 2250 Foulis St., Suite 2 Lackland AFB, TX 78236	AAFES (1) ATTN: RE-C PO Box 660202 Dallas, TX 75266-0202
---	---

SPECIAL INTEREST ORGANIZATIONS

Information Handling Services (1) 15 Inverness Way East Englewood, CO 80150	Construction Criteria Base (1) National Institute of Bldg Sciences Washington, DC 20005
---	---

Atch 2  
(1 of 1)

## APPENDIX C GLOSSARY

### C-1 ACRONYMS

AFCEE	Air Force Center for Engineering and the Environment
BIA	Bilateral Infrastructure Agreement
DoD	Department of Defense
HQUSACE	Headquarters, U.S. Army Corps of Engineers
HNFA	Host Nation Funded Construction Agreements
NAVFAC	Naval Facilities Engineering Command
SOFA	Status of Forces Agreements
UFC	Unified Facilities Criteria
U.S.	United States

**C-2            DEFINITION OF TERMS**