

**TRI-SERVICE FIRE PROTECTION  
ENGINEERING WORKING GROUP  
(TSPPEWG) GUIDE**

---

**FIRE PROTECTION  
ENGINEERING CRITERIA  
AND TECHNICAL GUIDE  
FOR FLEXIBLE SPRINKLER  
HOSE FITTINGS**



*This Page Intentionally Left Blank*

**TRI-SERVICE FIRE PROTECTION ENGINEERING WORKING GROUP GUIDE  
(TSFPEWG-G)**

**FIRE PROTECTION ENGINEERING CRITERIA AND TECHNICAL GUIDE  
FOR FLEXIBLE SPRINKLER HOSE FITTINGS**

Any copyrighted material included in this TSFPEWG Guide is identified at its point of use. Use of the copyrighted material apart from this TSFPEWG Guide must have the permission of the copyright holder.

U.S. ARMY CORPS OF ENGINEERS

NAVAL FACILITIES ENGINEERING SYSTEMS COMMAND

AIR FORCE CIVIL ENGINEER CENTER, (Preparing Activity)

Record of Changes (changes are indicated by \1\ ... /1/)

<b>Change No.</b>	<b>Date</b>	<b>Location</b>



*This Page Intentionally Left Blank*



## **FOREWORD**

This Tri-Service Fire Protection Engineering Working Group Guide supplements guidance found in other Unified Facilities Criteria, Unified Facility Guide Specifications, Defense Logistics Agency Specifications, and Service specific publications. All construction outside of the United States is also governed by Status of Forces Agreements (SOFA), Host Nation Funded Construction Agreements (HNFA), and in some instances, Bilateral Infrastructure Agreements (BIA.) Therefore, the acquisition team must ensure compliance with the most stringent of the TSFPEWG Guide, the SOFA, the HNFA, and the BIA, as applicable. This guidance on flexible sprinkler hose fittings is intended to be used to permit the use of the products in accordance with applicable codes and standards. The information in this TSFPEWG Guide is referenced in technical publications found on the Whole Building Design Guide. It is not intended to take the place of service specific doctrine, technical orders (TO), field manuals, technical manuals, handbooks, Tactics, Techniques, and Procedures (TTP) or contract specifications, but should be used along with these to help ensure flexible sprinkler hose fittings meet mission requirements.

TSFPEWG Guides are living documents and will be periodically reviewed, updated, and made available to users as part of the Services' responsibility for providing technical criteria for military construction, maintenance, repair, or operations. Headquarters, U.S. Army Corps of Engineers (HQUSACE), Naval Facilities Engineering Systems Command (NAVFAC), and Air Force Civil Engineer Center (AFCEC) are responsible for administration of this guide. Technical content of this TSFPEWG Guide is the responsibility of the Tri-Service Fire Protection Engineering Working Group (TSFPEWG). Defense agencies should contact the preparing activity for document interpretation. Send recommended changes with supporting rationale to the respective service TSFPEWG member.

TSFPEWG Guides are effective upon issuance and are distributed only in electronic media from the following source:

- Whole Building Design Guide website <https://www.wbdg.org/ffc/dod>.

Hard copies of TSFPEWG Guides printed from electronic media should be checked against the current electronic version prior to use to ensure that they are current.

### **AUTHORIZED BY:**

This TSFPEWG-G has been reviewed by the principal service members of the discipline working group (DWG).

*This Page Intentionally Left Blank*

**TRI-SERVICE PAVEMENTS WORKING GROUP GUIDE (TSPWG-G)  
NEW SUMMARY SHEET**

**Document:** TSPPEWG Guide 3-600-01.9-7-6, *Fire Protection Engineering Criteria and Technical Guide for Flexible Sprinkler Hose Fittings*

**Superseding:** None

**Description:** This guide details minimum performance requirements for selection, installation, and quality assurance of flexible sprinkler hose fittings in Department of Defense (DoD) facilities. It expands on the requirements of UFC 3-600-01, Chapter 9, and NFPA 13. This guide applies to DoD organizations evaluating use of flexible sprinkler hose fittings.

**Reasons for Document:** This guide provides information to assist users in determining flexible sprinkler hose fitting options that meet minimal performance requirements essential for these products.

**Unification Issues:** This guide has been issued by the TSPPEWG for immediate use. Other DOD agencies are reviewing the document for applicability to their activities.

**Note:** Use of the name or mark of any specific manufacturer, commercial product, commodity, or service in this guide does not imply endorsement by the Department of Defense (DOD).

*This Page Intentionally Left Blank*

**TABLE OF CONTENTS**

<b>CHAPTER 1 INTRODUCTION .....</b>	<b>1</b>
<b>1-1    PURPOSE AND SCOPE.....</b>	<b>1</b>
<b>1-2    APPLICABILITY.....</b>	<b>1</b>
<b>1-3    GENERAL BUILDING REQUIREMENTS.....</b>	<b>1</b>
<b>1-4    GLOSSARY.....</b>	<b>1</b>
<b>1-5    REFERENCES.....</b>	<b>1</b>
<b>CHAPTER 2 TECHNICAL REQUIREMENTS .....</b>	<b>3</b>
<b>2-1    BACKGROUND.....</b>	<b>3</b>
<b>2-2    WHAT PRODUCTS ARE DISCUSSED IN THIS GUIDE? .....</b>	<b>3</b>
<b>2-3    WHY IS THIS GUIDE NECESSARY? .....</b>	<b>3</b>
<b>2-4    WHAT COMPONENTS MAKE UP A FLEXIBLE SPRINKLER HOSE             FITTING?.....</b>	<b>4</b>
<b>2-5    WHAT TYPE OF CONNECTION IS USED TO CONNECT THE             SPRINKLER HOSE FITTING TO THE BRANCH LINE? .....</b>	<b>4</b>
2-5.1    Brand Line Adapter.....	4
2-5.2    Flexible Hose.....	6
2-5.3    Reducer.....	6
2-5.4    Bracket.....	7
<b>2-6    WHY WERE FLEXIBLE SPRINKLER HOSE FITTINGS DEVELOPED             AND HOW HAVE THEY EVOLVED?.....</b>	<b>7</b>
<b>2-7    WHAT ARE THE APPROPRIATE USES FOR A FLEXIBLE SPRINKLER             HOSE FITTING? .....</b>	<b>8</b>
<b>2-8    WHAT ARE INAPPROPRIATE USES FOR FLEXIBLE SPRINKLER             HOSE FITTINGS? .....</b>	<b>9</b>
<b>2-9    CAN FLEXIBLE SPRINKLER HOSE FITTINGS BE USED WITH ANY             CEILING SYSTEM? .....</b>	<b>9</b>
<b>2-10   CAN FLEXIBLE SPRINKLER HOSE FITTINGS BE USED IN DRY PIPE             SPRINKLER SYSTEMS?.....</b>	<b>10</b>
<b>2-11   CAN FLEXIBLE SPRINKLER HOSE FITTING COMPONENTS FROM             TWO OR MORE MANUFACTURERS BE USED TOGETHER?.....</b>	<b>10</b>
<b>2-12   CAN FLEXIBLE SPRINKLER HOSE FITTINGS FROM DIFFERENT             MANUFACTURERS BE USED ON THE SAME SYSTEM? .....</b>	<b>10</b>
<b>2-13   WHAT ARE THE ADVANTAGES OF USING FLEXIBLE SPRINKLER             HOSE FITTINGS? .....</b>	<b>10</b>

2-13.1	How Do the Cost and Installation Times for a Flexible Sprinkler Hose Fittings and Hard-Piped Drops Compare? .....	11
2-13.2	How Do Flexible Sprinkler Hose Fittings and Hard-Piped Drops Compare During Seismic Events? .....	11
2-13.3	Can Flexible Sprinkler Hose Fittings Be Used for Center-of-Tile Installation of Sprinklers? .....	11
<b>2-14</b>	<b>WHAT ARE THE DISADVANTAGES OF USING FLEXIBLE SPRINKLER HOSE FITTINGS? .....</b>	<b>12</b>
2-14.1	How Does the Cost of Flexible Sprinkler Hose Fittings Compare to Hard-Piped Drops? .....	12
2-14.2	How Does the Friction Loss Through a Flexible Hose Fitting Compare to a Hard-Piped Drop? .....	12
2-14.3	Can Anyone Install Flexible Hose Fittings? .....	12
2-14.4	Can Sprinklers Be Relocated After Installation on Flexible Sprinkler Hose Fittings? .....	12
<b>CHAPTER 3</b>	<b>DESIGN .....</b>	<b>15</b>
<b>3-1</b>	<b>INTRODUCTION. ....</b>	<b>15</b>
3-1.1	CONUS Projects. ....	15
3-1.2	OCONUS Projects. ....	15
<b>3-2</b>	<b>THE DESIGN PROCESS. ....</b>	<b>15</b>
<b>3-3</b>	<b>APPROVAL TO USE FLEXIBLE SPRINKLER HOSE FITTINGS. ....</b>	<b>16</b>
<b>3-4</b>	<b>USE OR APPLICATIONS. ....</b>	<b>16</b>
3-4.1	Acoustic Ceiling Tile Ceilings. ....	17
3-4.2	Gypsum Board (Hard Lid) Ceilings. ....	17
3-4.3	Sidewall Applications. ....	18
3-4.4	Clean Rooms. ....	19
3-4.5	Industrial Ducts. ....	19
3-4.6	Institutional Applications Such as Brigs, Prisons, and Psychiatric Wards. ....	20
3-4.7	Walk-in Freezers and Coolers. ....	20
3-4.8	Dry Systems. ....	21
3-4.9	Localized Areas Requiring Dry Sprinklers. ....	22
3-4.10	Seismic Areas. ....	22
3-4.11	Specialty Ceiling Applications. ....	23
<b>3-5</b>	<b>FLEXIBLE SPRINKLER HOSE FITTING PERFORMANCE REQUIREMENTS. ....</b>	<b>24</b>

3-5.1	Flexible Sprinkler Hose Designs.....	24
3-5.2	Bend Radius.....	26
3-5.3	Number of Bends.....	26
3-5.4	Diameter and Equivalent Length.....	27
3-5.5	Branch Line Adapters.....	28
3-5.6	Reducers.....	28
3-5.7	Connection to Hose.....	29
3-5.8	Length.....	31
3-5.9	Brackets.....	31
3-5.10	Hose Couplings.....	34
<b>3-6</b>	<b>SELECTION OF FLEXIBLE SPRINKLER HOSE FITTING MODEL AND HYDRAULIC PERFORMANCE.....</b>	<b>35</b>
3-6.1	FlexHead® Options.....	35
<b>3-7</b>	<b>DESIGN DOCUMENTS.....</b>	<b>38</b>
<b>3-8</b>	<b>FREQUENTLY ASKED QUESTIONS REGARDING USE AND DESIGN OF FLEXIBLE HOSE FITTINGS.....</b>	<b>40</b>
3-8.1	Can Flexible Sprinkler Hose Fittings Be Used in DoD Facilities? .....	40
3-8.2	Can Flexible Sprinkler Hose Fittings Be Used for CONUS Projects? .....	40
3-8.3	What Codes and Standards Apply to Use of Flexible Sprinkler Hose Fittings? .....	40
3-8.4	What Code, Standards, and Installation Requirements Apply to CONUS Projects? .....	40
3-8.5	Can Flexible Sprinkler Hose Fittings Be Used for OCONUS Projects? .....	40
3-8.6	What Code, Standards, and Installation Requirements Apply to Flexible Sprinkler Hose Fittings for OCONUS Projects? .....	40
3-8.7	What Is a Flexible Sprinkler Hose Fitting?.....	41
3-8.8	Are Flexible Sprinkler Hose Fittings Limited to Use in Office Buildings? .....	41
3-8.9	Can Flexible Sprinkler Hose Fittings Be Used in Dry Pipe Sprinkler Systems? .....	41
3-8.10	What Length of Flexible Sprinkler Hose Fitting Is Permitted for Use? .....	42
3-8.11	What Type of Connection Is Used to Connect the Sprinkler Hose System to the Branch Line? .....	42
3-8.12	How Are Flexible Sprinkler Hose Fittings Included in Hydraulic Calculations? .....	42
3-8.13	Can Flexible Sprinkler Hose Fitting Lengths Be Changed in the Field? .....	42

3-8.14	How Many Bends Can Be Made in a Flexible Sprinkler Hose Fitting? .....	42
3-8.15	What Is the Minimum Bend That Can Be Made in a Flexible Sprinkler Hose Fitting? .....	42
3-8.16	How Are Flexible Sprinkler Hose Systems Supported? .....	43
<b>CHAPTER 4</b>	<b>INSTALLATION AND INSPECTION .....</b>	<b>45</b>
<b>4-1</b>	<b>INTRODUCTION. ....</b>	<b>45</b>
<b>4-2</b>	<b>INSTALLATION. ....</b>	<b>45</b>
4-2.1	NFPA 13. ....	45
4-2.2	Listing Requirements.....	46
4-2.3	Manufacturer’s Installation Instructions. ....	47
<b>4-3</b>	<b>INSTALLATION AND INSPECTIONS.....</b>	<b>48</b>
<b>CHAPTER 5</b>	<b>QUALITY ASSURANCE.....</b>	<b>55</b>
<b>5-1</b>	<b>INTRODUCTION. ....</b>	<b>55</b>
<b>5-2</b>	<b>APPROVAL OF COMPONENTS. ....</b>	<b>55</b>
<b>5-3</b>	<b>REVIEW OF DESIGN DOCUMENTS.....</b>	<b>55</b>
5-3.1	Design Drawing Elements.....	55
5-3.2	Minimum Design Document Criteria.....	56
<b>5-4</b>	<b>INSPECTIONS. ....</b>	<b>57</b>
5-4.1	Field Inspections.....	57
5-4.2	Early Inspections. ....	58
5-4.3	Progress Inspections.....	59
5-4.4	Minimum Inspection Criteria. ....	61
<b>APPENDIX A</b>	<b>DESIGN PROCESS FLOW CHART .....</b>	<b>65</b>
<b>APPENDIX B</b>	<b>SAMPLE REQUEST FOR USE .....</b>	<b>67</b>
<b>APPENDIX C</b>	<b>EXAMPLE TECHNICAL SPECIFICATIONS .....</b>	<b>69</b>
<b>APPENDIX D</b>	<b>INSTALLATION - COMMERCIAL SPRINKLER SYSTEM</b>	
	<b>MPO-24-BKT-2 .....</b>	<b>71</b>
<b>APPENDIX E</b>	<b>EXAMPLE QUALITY CONTROL CHECKLIST .....</b>	<b>75</b>
<b>APPENDIX F</b>	<b>GLOSSARY.....</b>	<b>79</b>
<b>F-1</b>	<b>ACRONYMS.....</b>	<b>79</b>
<b>F-2</b>	<b>DEFINITION OF TERMS.....</b>	<b>80</b>
<b>APPENDIX G</b>	<b>REFERENCES.....</b>	<b>81</b>



## FIGURES

Figure 2-1	Diagram Showing the Separate Components of a Flexible Hose Fitting (Courtesy of ASC).....	4
Figure 2-2	Example Weld x Groove Branch Line Adapter (Courtesy of ASC).....	5
Figure 2-3	Example Groove, Threaded, and Welded Branch Line Adapters (Courtesy of TERPconsulting).....	5
Figure 2-4	Example Corrugated Unbraided Helical Flexible Hose (Courtesy of TERPconsulting).....	6
Figure 2-5	Examples of a Flexible Hose Fittings Having a Straight and 90° Reducers (Courtesy of ASC) .....	6
Figure 2-6	Example Bracket Attached to Ceiling Grid (Courtesy of Victaulic)....	7
Figure 3-1	Center-of-Tile Installation Using a Flexible Sprinkler Hose Fitting (Courtesy of Victaulic) .....	17
Figure 3-2	Hard Lid Ceiling Installation Viewed from Above the Ceiling (Courtesy of ASC).....	18
Figure 3-3	Sidewall Sprinkler Installation (Courtesy of ASC) .....	18
Figure 3-4	Industrial Duct Sprinkler Installation on Round Duct (Courtesy of Victaulic) .....	19
Figure 3-5	Duct Mounting Block with Poly Bag Assembly (Courtesy of TERPconsulting).....	20
Figure 3-6	Walk-in Cooler Installation (Courtesy of Victaulic).....	21
Figure 3-7	Flexible Sprinkler Hoses with Dry Pendent Sprinklers (Courtesy of ASC).....	21
Figure 3-8	Dry Pendent Sprinkler Installation (Courtesy of Victaulic) .....	22
Figure 3-9	Ceiling Damage Caused by Earthquake (Courtesy of Accel Fire Protection) .....	23
Figure 3-10	Concealed Sprinkler Damaged by Earthquake (Courtesy of Accel Fire Protection).....	23
Figure 3-11	Special Application Sprinkler and Ceiling Installation (Courtesy of ASC).....	24
Figure 3-12	Braided Sprinkler Hose (Courtesy of ASC) .....	25
Figure 3-13	Standard and High-Pressure Braiding (Courtesy of TERPconsulting).....	25
Figure 3-14	Example of Bend Radius and Multiple Bends (Courtesy of TERPconsulting).....	26
Figure 3-15	Bends in a Flexible Sprinkler Hose (Courtesy of ASC) .....	27
Figure 3-16	Inside Diameter of Hose (Courtesy of TERPconsulting).....	28
Figure 3-17	Branch Line Adapters (Courtesy of ASC) .....	28
Figure 3-18	Angled and Straight Reducers (Courtesy of TERPconsulting) .....	29
Figure 3-19	Comparison of Welded and Adjustable Reducers for Connections of Sprinklers to The Flexible Hose (Courtesy of TERPconsulting) .....	30
Figure 3-20	Union Connections to Hose (Courtesy of TERPconsulting).....	30
Figure 3-21	Sprinkler Hose Length (Courtesy of ASC) .....	31
Figure 3-22	Open Gate Attachment Gate or Hub (Courtesy of ASC) .....	33
Figure 3-23	Ceiling Grid Brackets (Courtesy of Victaulic and ASC) .....	33

**Figure 3-24 Wood Ceiling Brackets (Courtesy of Victaulic)..... 33**

**Figure 3-25 Metal Ceiling Brackets (Courtesy of Victaulic) ..... 34**

**Figure 3-26 Hose Coupling (Courtesy of ASC) ..... 34**

**Figure 3-27 Example Sprinkler System Layout Using Flexible Sprinkler Hose Fittings (Courtesy of TERPconsulting)..... 39**

**Figure 3-28 Example Sprinkler System Isometric Using Flexible Sprinkler Hose Fittings (Courtesy of TERPconsulting)..... 39**

**Figure 3-29 Example Flexible Hose System (Courtesy of TERPconsulting) ..... 41**

**Figure 3-30 Example Bend Radius Tool on Hose With Two Bends (Courtesy of ASC)..... 43**

**Figure 4-1 Caution Label on Bracket (Courtesy of TERPconsulting) ..... 46**

**Figure 4-2 Example Sprinkler System Layout Using Flexible Sprinkler Hose Fittings (Courtesy of TERPconsulting)..... 48**

**Figure 4-3 Center-of-Tile Installation Using Flexible Sprinkler Hose Fittings (Courtesy of TERPconsulting)..... 49**

**Figure 4-4 Ceiling Grid with Manufacturer’s Label (Courtesy of TERPconsulting)..... 49**

**Figure 4-5 Rough-In Installation for Flexible Sprinkler Hose Fittings (Courtesy of TERPconsulting) ..... 50**

**Figure 4-6 Flexible Sprinkler Hose Fitting with Grooved Branch Line Adapter (Courtesy of ASC)..... 50**

**Figure 4-7 Example Flexible Sprinkler Hose Fitting (Courtesy of TERPconsulting)..... 51**

**Figure 4-8 Kink or Shallow Bend in Flexible Hose (Courtesy of Ralph K. Foster, III, PE, FSFPE)..... 51**

**Figure 4-9 Unbraided and Braided Hose with Bends Not Meeting the Minimum Radius (Courtesy of Ralph K. Foster, III, PE, FSFPE)..... 52**

**Figure 4-10 Example Bracket with Label (Courtesy of Victaulic) ..... 52**

**Figure 4-11 Bracket with Tamper-Resistant Screw Installed in Ceiling Grid (Courtesy of TERPconsulting)..... 53**

**Figure 4-12 Finished Center of Tile Installation Using Flexible Sprinkler Hose Fittings (Courtesy of TERPconsulting)..... 53**

**Figure 5-1 Flexible Hose with 7 Bends (Courtesy of FlexHead®/ASC)..... 58**

**Figure 5-2 Installation of Flexible Hose Fitting with Grooved Branch Line Adapter (Courtesy of Victaulic)..... 59**

**Figure 5-3 Kink in Flexible Hose (Courtesy of Ralph K. Foster, III, PE, FSFPE) 59**

**Figure 5-4 Bend Radius Less Than Minimum (Courtesy of Ralph K. Foster, III, PE, FSFPE)..... 60**

**Figure 5-5 Unprotected Sprinklers Installed on Flexible Sprinkler Hose Assemblies (Courtesy of TERPconsulting)..... 60**

**Figure 5-6 Bracket with Label (Courtesy of FlexHead®/ASC) ..... 61**

**Figure 5-7 Bracket with Tamper-Resistant Screw Attached to Ceiling Grid (Courtesy of FlexHead®/ASC)..... 61**

**TABLES**

**Table 3-1 FM Approved Options for Hard Lid Applications (Courtesy of FlexHead®/ASC) ..... 37**

**Table 3-2 UL-Listed Options for Hard Lid Applications (Courtesy of FlexHead®/ASC) ..... 38**

*This Page Intentionally Left Blank*

## CHAPTER 1 INTRODUCTION

### 1-1 PURPOSE AND SCOPE.

This guide details minimum performance requirements for the selection, installation practices, and quality assurance of flexible sprinkler hose fittings in DoD facilities. It applies to all new construction, renovation, modernization, and rehabilitation of fire sprinkler systems in facilities.

It supplements criteria in National Fire Protection Association (NFPA) 13, *Standard for the Installation of Sprinkler Systems* and UFC 3-600-01, *Fire Protection Engineering for Facilities*, Chapter 9.

### 1-2 APPLICABILITY.

This guide applies to DoD organizations evaluating use of flexible sprinkler hose fittings. It expands requirements of UFC 3-600-01, paragraph 1-3, and provides additional information to meet requirements of paragraph 9-7.6.8.

### 1-3 GENERAL BUILDING REQUIREMENTS.

UFC 1-200-01, *DoD Building Code*, provides applicability of model building codes and government-unique criteria for typical design disciplines and building systems, as well as for accessibility, antiterrorism, security, high performance and sustainability requirements, and safety. Use this guide in addition to UFC 1-200-01, UFC 3-600-01, referenced UFCs, and referenced government criteria.

### 1-4 GLOSSARY.

Appendix F contains acronyms, abbreviations, and terms.

### 1-5 REFERENCES.

Appendix G contains a list of references used in this guide. The publication date of the code or standard is not included; unless otherwise specified, the most recent edition of the referenced publication applies.

*This Page Intentionally Left Blank*

## CHAPTER 2 TECHNICAL REQUIREMENTS

### 2-1 BACKGROUND.

This chapter provides background information regarding flexible sprinkler hose fittings, their appropriate and inappropriate uses, and the advantages and disadvantages of using these products.

**Example:** Flexible sprinkler hose fittings are often used in suspended acoustical ceilings in seismic areas to limit oversized escutcheons, but they can also be used in tenant improvements where high turnover is anticipated to reduce remodeling costs and the construction schedule.

### 2-2 WHAT PRODUCTS ARE DISCUSSED IN THIS GUIDE?

The term “flexible sprinkler hose fitting” refers to flexible hose used to attach a sprinkler to a branch line. This class of products is referenced in other documents in the fire protection industry as flexible sprinkler hose drops, flexible sprinkler hose, flexible sprinkler hose assemblies, and flexible sprinkler hose systems. NFPA 13, *Standard for the Installation of Sprinkler Systems*, refers to these products as flexible sprinkler hose fittings. Underwriters Laboratories (UL) 2443, *Standard for Flexible Sprinkler Hose with Fittings for Fire Protection Service*, and Factory Mutual (FM) 1637, *Approval Standard for Flexible Sprinkler Hose with Threaded End Fittings*, refer to the products as flexible sprinkler hose with fittings. All these terms apply to the products discussed in this guide.

The terms “flexible coupling” and “flexible pipe” are also used in NFPA 13 and in the fire protection industry, but refer to different products. Flexible coupling refers to grooved fittings designed for seismic and other applications to allow for additional range of movement beyond that which is typically found with rigid couplings intended to limit movement. Flexible pipe is similar to a flexible sprinkler hose fitting in its construction (uses a corrugated tube with braided sheathing), but is used for large diameter branch line or main piping applications, and flexible pipes do not include all features found in a flexible sprinkler hose fitting. Interested readers should review NFPA 13 and manufacturers’ web sites for additional information on these topics which are outside the scope of this guide.

### 2-3 WHY IS THIS GUIDE NECESSARY?

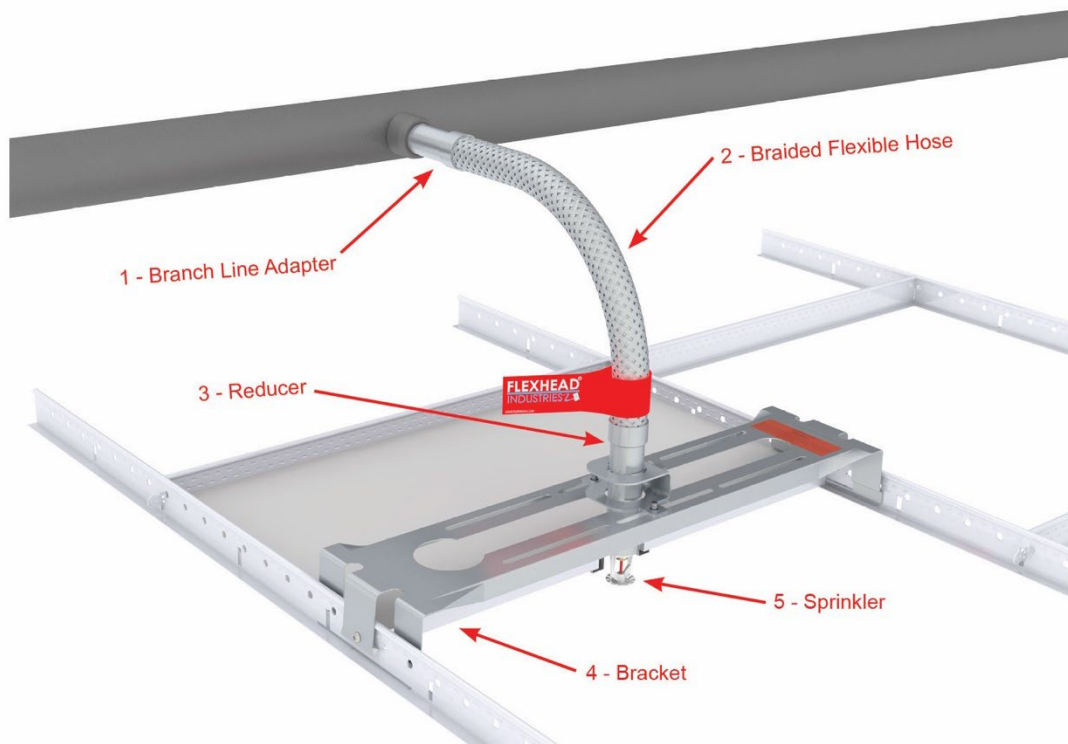
Installation of flexible sprinkler hose fittings by untrained and/or unskilled personnel and using products that differ from those approved or are poor quality has resulted in a lack of confidence in use of these products. Using braided flexible sprinkler hose fittings meeting the listing requirements of UL 2443 or FM 1637 and installed by trained personnel in accordance with the manufacturer’s instructions will provide the intended quality and performance in Continental United States (CONUS) installations. Braided products meeting UL 2443, FM 1637, or other accepted international standards in Outside the Continental United States (OCONUS) applications can be used when labor is trained to install the specific product included in the design. This guide is intended to

assist reviewers in evaluating and approving flexible hose fittings for use in both CONUS and OCONUS applications.

## 2-4 WHAT COMPONENTS MAKE UP A FLEXIBLE SPRINKLER HOSE FITTING?

Flexible sprinkler hose fittings are composed of four components: (1) a branch line adapter, (2) flexible hose, (3) reducer for connecting the sprinkler to the flexible sprinkler hose, and (4) bracket. The terminology used to describe these components might differ in the literature used by manufacturers, but the components remain the same.

**Figure 2-1 Diagram Showing the Separate Components of a Flexible Hose Fitting (Courtesy of ASC<sup>1</sup>)**



## 2-5 WHAT TYPE OF CONNECTION IS USED TO CONNECT THE SPRINKLER HOSE FITTING TO THE BRANCH LINE?

### 2-5.1 Branch Line Adapter.

The branch line adapter is the inlet fitting or component used to attach the flexible hose to the sprinkler system branch line. There are options to allow for different joining methods, such as threaded and grooved connections. In some cases, these fittings will be specific to the selected product for the project since the fittings will have threads or

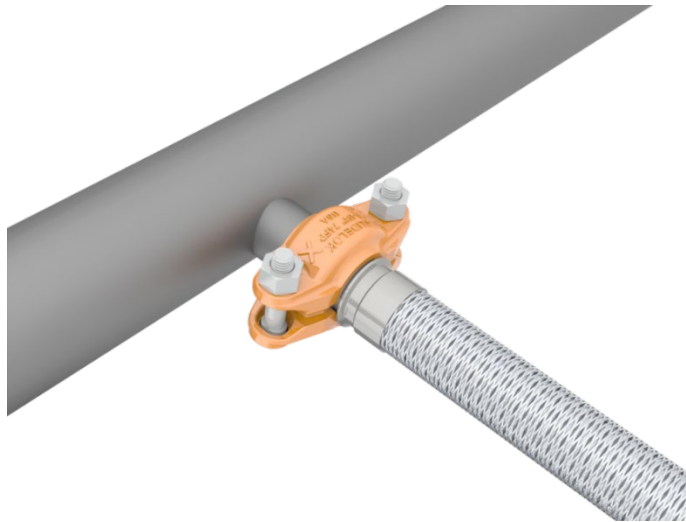
<sup>1</sup> ASC Engineered Solutions (formerly Anvil and Smith-Cooper)



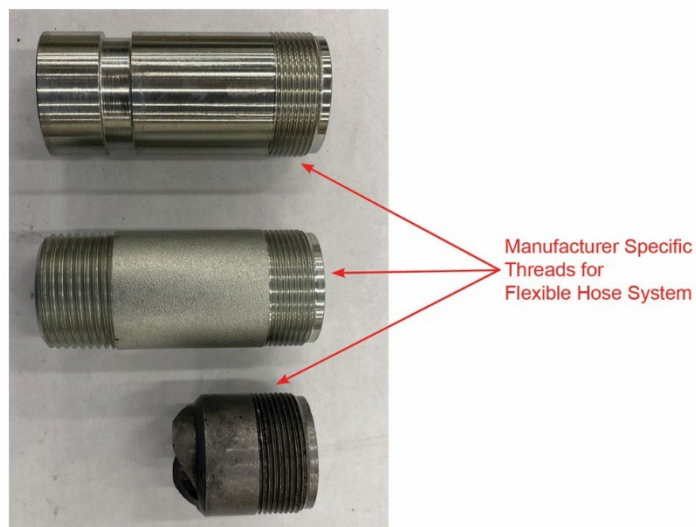
grooves produced only by the individual manufacturer of the product. These specialty threads allow products to be modular in design but limit use to products made by a specific manufacturer.

Branch line adapters are listed for connection to male welded outlet fittings, female welded outlet fittings, male threaded outlet fittings, female threaded outlet fittings, and grooved outlet fittings.

**Figure 2-2 Example Weld x Groove Branch Line Adapter  
(Courtesy of ASC)**



**Figure 2-3 Example Groove, Threaded, and Welded Branch Line Adapters  
(Courtesy of TERPconsulting)**



### 2-5.2 Flexible Hose.

The flexible hose is the corrugated tube with or without an outer braided sheathing. The hose can have either a helical or annular design, which is determined by the manufacturer based on the intended performance needs for the individual product. Flexible hose length is limited to a maximum of 6 feet (1830 millimeters) to minimize the potential for movement and inadequate support.

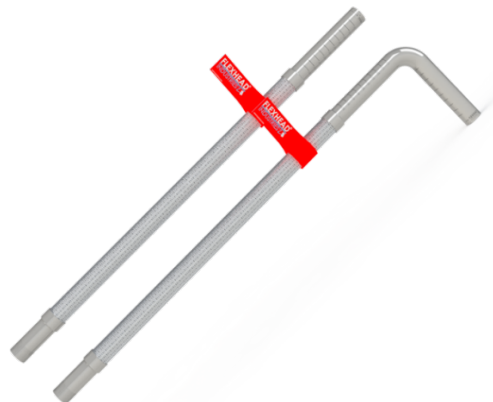
**Figure 2-4 Example Corrugated Unbraided Helical Flexible Hose  
(Courtesy of TERPconsulting)**



### 2-5.3 Reducer.

The reducer is the outlet fitting or component used to connect the flexible hose to the sprinkler. This will transition the flexible hose diameter to the appropriate diameter to allow for the connection of the individual sprinkler. Most will have threaded connections, but at least one manufacturer has a grooved connection option. The reducer fittings can be configured as a straight drop or in a 90° elbow pattern.

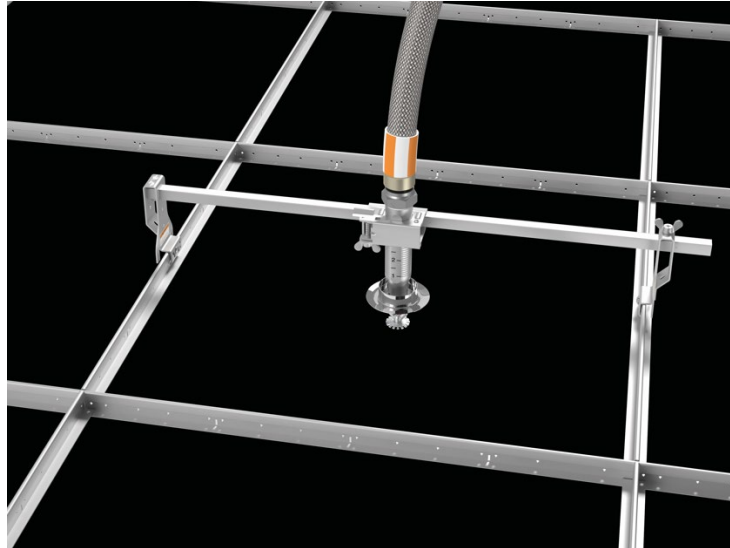
**Figure 2-5 Examples of a Flexible Hose Fittings Having  
a Straight and 90° Reducers  
(Courtesy of ASC)**



#### 2-5.4 Bracket.

The bracket is the anchoring component used to support the flexible hose system and is used for attachment to the ceiling assembly or structure. The design and configuration of the bracket should be listed as part of the assembly and either allow for universal application for different ceiling and construction types or be limited to a specific construction type or application.

**Figure 2-6 Example Bracket Attached to Ceiling Grid (Courtesy of Victaulic)**



#### 2-6 WHY WERE FLEXIBLE SPRINKLER HOSE FITTINGS DEVELOPED AND HOW HAVE THEY EVOLVED?

Flexible sprinkler hose fitting technology was first introduced in Japan in the 1980s to improve the performance of sprinkler system drops during seismic events. In the 1990s, the technology was adapted to commercial and industrial applications in the United States (U.S.). Flexible sprinkler hose fittings were first used in duct applications to allow for easy inspection and replacement of sprinklers. By 2006, the International Building Code (IBC) had identified flexible sprinkler hose fittings as a “preferred method.” Flexible sprinkler hose fittings were used under the “New Technology” provision of NFPA 13 until Section 9.2.1.3.3, “Flexible Sprinkler Hose Fittings,” was added to the 2007 edition.

The application of flexible sprinkler hose fittings has become widely accepted in commercial practice in the U.S. and abroad. Selection of the correct and appropriate flexible sprinkler hose fitting(s) requires close attention to details at the start and throughout a project. Over 50 manufacturers have UL-listed or FM-approved products with varying levels of performance. Each manufacturer produces multiple flexible sprinkler hose fitting models and a variety of hose lengths resulting in hundreds of specific product models to choose from. Additionally, each manufacturer offers differing bracketry with different installation requirements as part of the product listings. Selecting

an appropriate product presents a challenge to specifiers, designers, and end users. This guide provides information to assist in selecting appropriate options that satisfy performance requirements.

## **2-7 WHAT ARE THE APPROPRIATE USES FOR A FLEXIBLE SPRINKLER HOSE FITTING?**

- Providing flexibility in seismic applications. The flexible hose allows the sprinkler and drop to move with the ceiling, preventing unwanted damage to the sprinkler, drop, or ceiling due to independent movement. This reduces the potential for accidental discharge during a seismic event. When hard-piped drops are used, there is often significant damage during seismic events. In many instances, the differential movement during earthquakes causes sprinklers attached to hard-piped drops to be damaged or pushed above the ceiling, preventing proper discharge.
- Providing flexibility in areas where structural movement or variations are possible. Structural movement has been observed in areas having clay soil causing displacement of sprinkler escutcheons.
- System installations where return bends are required or used. Return bends are required when raw water supplies are used, and where pendent sprinklers are supplied from a dry pipe or pre-action sprinkler system in heated areas.
- Accommodating center-of-tile requirements. It is common to use flexible sprinkler hose assemblies when there is a need for center-of-tile or preferred location of sprinklers. Bracketry is designed to allow for quarter-point or center-of-tile installation. The versatility in the design of flexible sprinkler hose fittings has been found to significantly reduce installation time for fitters as well as lessen the impact of inaccuracies in piping or ceiling installations, both horizontally and vertically. The flexible hose fittings accommodate the relocation of sprinklers to the center of tile and prevent the need to cut back drops, saving on installation time.
- Installation of sprinklers in ducts. This is one of the first applications in the United States. The use of flexible hose assemblies makes routine inspections of sprinklers and maintenance required to replace plastic bags installed over sprinklers to protect against accumulations of dust, paint, or grease easier.
- Protection of clean rooms. Special application clean room models are available which allow for differential movement of the ceiling, provide specific bracketry for clean room ceilings, and provide protection against clean room contamination.
- Protection of institutional occupancies in pendent and sidewall applications. Attachment clamps are used to stabilize the reducer on the flexible sprinkler hose fitting to prevent the assembly from being pulled away from the wall or ceiling.

- Protection in a walk-in cooler or freezer. Special brackets allow for attachment to walk-in coolers and freezers, allowing for flexure with the structure while maintaining the integrity of the freezer seal.
- Dry flexible sprinkler hose fittings where localized protection against freezing is necessary.
- Dry flexible sprinkler hose fittings can be used in dry pipe systems since the entire flexible sprinkler hose system is dry.

## **2-8 WHAT ARE INAPPROPRIATE USES FOR FLEXIBLE SPRINKLER HOSE FITTINGS?**

- Snaking a flexible sprinkler hose around ducts, between pipes or conduits, through joist channels or other features when there is less than a 2-inch (51-millimeter) clearance in a seismic application, or when causing too small of a bend radius, too many bends, or stretching the flexible hose fitting.
- Using a flexible hose that is too long for the installation and coiling the unnecessary length.
- Using a longer flexible hose system than is included in the design.
- Adding more bends than the maximum permitted in the design or listing.
- Using a too-small bend radius (tighter than what is defined in the listing).
- Using a flexible hose fitting in an application requiring repeated movement which has not been tested for high flexibility in accordance with the UL 2443 fatigue test or to FM 1637 requirements. The limited flexibility testing exercises the flexible sprinkler hose fittings through 100 cycles of repeated flexing, where the UL 2443 high flexibility test and FM 1637 fatigue test exercise the flexible sprinkler hose fitting through 50,000 cycles of repeated flexing.
- Using a flexible sprinkler hose fitting having a length exceeding 6 feet (1829 millimeters) in a CONUS application. NFPA 13 and UL 2443 limit flexible sprinkler hose fittings to a maximum length of 6 feet. OCONUS applications might permit two flexible hoses to be coupled together or permit flexible hoses to have lengths exceeding 6 feet up to 12 feet (3658 millimeters) based on the requirements of local codes and test standards.
- Installing a flexible sprinkler hose fitting through a fire wall.

## **2-9 CAN FLEXIBLE SPRINKLER HOSE FITTINGS BE USED WITH ANY CEILING SYSTEM?**

No. When installed and supported by suspended ceilings, the ceiling must meet ASTM C635/C635M, *Standard Specification for Manufacture, Performance, and Testing of Metal Suspension Systems for Acoustical Tile and Lay-in Panel Ceilings*, and must be installed in accordance with ASTM C636/C636M, *Standard Practice for Installation of*

*Metal Ceiling Suspension Systems for Acoustical Tile and Lay-in Panels.* The Qualified Fire Protection Engineer (QFPE) will need to certify that the ceiling type meets these requirements when flexible sprinkler hose fittings are used.

**2-10 CAN FLEXIBLE SPRINKLER HOSE FITTINGS BE USED IN DRY PIPE SPRINKLER SYSTEMS?**

Yes, there are listed dry pendent and sidewall sprinklers that include a dry flexible hose as part of the assembly. These dry flexible sprinkler hose assemblies can be used in dry pipe, preaction, deluge and wet pipe sprinkler systems. There are also listed products which will allow for connection to threaded dry barrel sprinkler applications for freezers and coolers and other applications where the assembly is supplied by wet pipe, preaction, or deluge sprinkler systems.

**2-11 CAN FLEXIBLE SPRINKLER HOSE FITTING COMPONENTS FROM TWO OR MORE MANUFACTURERS BE USED TOGETHER?**

No. The four components of a flexible sprinkler hose fitting are tested and listed together as part of the product listing, so intermixing products from different manufacturers is not permitted. Although many flexible sprinkler hose fittings are modular in design, meaning that components can be changed to meet specific project needs, many products use thread profiles that will prevent connection with another manufacturer's products.

**2-12 CAN FLEXIBLE SPRINKLER HOSE FITTINGS FROM DIFFERENT MANUFACTURERS BE USED ON THE SAME SYSTEM?**

Yes, if accounted for in the design and installation. However, the use of different models produced by different manufacturers should be avoided to maintain appropriate quality control.

**2-13 WHAT ARE THE ADVANTAGES OF USING FLEXIBLE SPRINKLER HOSE FITTINGS?**

- Reduced installation time.
- Reduced labor cost.
- Improved performance in seismic events.
- Removes need for oversized holes in seismic applications.
- Allows for center-of-tile or preferred locations.
- Allows for adjustment of height for concealed, pendent, and semi-recessed sprinkler changes.
- Allows for appropriate future relocation of sprinklers in accordance with design and listing limitations.
- Allows for the omission of a hanger on arm-overs greater than 24 inches (610 millimeters) in length.

- Provides corrosion resistance since components are stainless steel.
- Minimizes potential for dissimilar metals (galvanic) corrosion.
- Eliminates the need for upward restraint. Brackets for flexible sprinkler hose fittings meet the NFPA 13 requirements for restraint against upward movement for sprinkler systems having a maximum working pressure greater than 100 pounds per square inch with pendent sprinklers positioned below ceilings. Hard-piped arm over installations require a hanger design for restraint against upward movement to be within 12 inches of the end sprinkler for steel pipe or 6 inches for copper.
- Allows for pressure test against sprinklers during rough-in prior to the ceiling system being installed. With hard-piped installations, the drops are measured and cut back after the ceiling is installed, so the test with sprinklers in place cannot be done until after the ceiling system is installed and the drops are cut back.

### **2-13.1 How Do the Cost and Installation Times for a Flexible Sprinkler Hose Fittings and Hard-Piped Drops Compare?**

The material cost is higher for flexible sprinkler hose fittings. However, the time to install a flexible sprinkler hose fitting is significantly less than is required for a hard-piped drop. The installation time for hard-piped drops can be four to six times greater than the time required to install a flexible hose system due to the increased number of joints. This reduced time results in reduced labor cost which results in the per unit cost of a sprinkler using a flexible sprinkler hose fitting being approximately equal to a sprinkler installed on a hard-piped drop.

### **2-13.2 How Do Flexible Sprinkler Hose Fittings and Hard-Piped Drops Compare During Seismic Events?**

Use of flexible sprinkler hose fittings in seismic areas eliminates the need to have oversized holes in ceilings. Flexible sprinkler hose fittings are evaluated for vibration and motion which would be encountered during seismic events. In situ performance during earthquakes has demonstrated that sprinklers will remain in place, below the ceiling, preventing damage caused by the sprinkler moving in a different direction from the ceiling, or the sprinkler being trapped above the ceiling. Hard-piped sprinklers will channel openings in ceilings, damaging the sprinklers and ceiling, and in many cases cause accidental discharge.

### **2-13.3 Can Flexible Sprinkler Hose Fittings Be Used for Center-of-Tile Installation of Sprinklers?**

Yes, brackets are designed to accommodate the center-of-tile or quarter-point installation of sprinklers. Flexible sprinkler hose fittings can also accommodate changes in ceiling height or ceiling tile layout without the need for cut backs or modifications to piping.

## **2-14 WHAT ARE THE DISADVANTAGES OF USING FLEXIBLE SPRINKLER HOSE FITTINGS?**

- Material cost.
- Increased hydraulic demand.
- Required specialized training and experience by the manufacturer on the specific product prior to use.
- Inappropriate relocation of sprinklers beyond design or listing limitations.
- Bad installations in the past might be a deterrent.

### **2-14.1 How Does the Cost of Flexible Sprinkler Hose Fittings Compare to Hard-Piped Drops?**

The material cost of a flexible sprinkler hose fitting is higher than the cost of a hard-piped drop. Labor costs for hard-piped drop installations can exceed labor costs for flexible sprinkler hose fitting installations by up to 600 percent.

### **2-14.2 How Does the Friction Loss Through a Flexible Hose Fitting Compare to a Hard-Piped Drop?**

The friction loss through a flexible hose fitting will be significantly higher than that of an equivalent hard-piped return bend. The hydraulic demand is based on the hose length, hose diameter, and number of bends included in the design. Adding more bends than permitted or using a flexible hose fitting with a different length or hose diameter will change the hydraulic performance of the sprinkler system.

### **2-14.3 Can Anyone Install Flexible Hose Fittings?**

Yes, but installation requires training and experience with individual products to ensure that installers understand product limitations and uses. The sprinkler system installer must be regularly engaged in the installation of the type and complexity of flexible sprinkler hose fittings specified in the contract documents and must have installed flexible sprinkler hose fittings for at least three systems that have performed in the manner intended for a period of not less than six months. However, it should be noted that training for installation of flexible sprinkler hose fittings entails less than training for hard pipe drop installation.

### **2-14.4 Can Sprinklers Be Relocated After Installation on Flexible Sprinkler Hose Fittings?**

Flexible hose fittings can be relocated appropriately as part of a remodel, or inappropriately by other trades or occupants after installation. Relocation of the sprinklers changes spacing and protection area of coverage. This will impact the hydraulic performance of the sprinkler system such that the system might have sprinklers exceeding maximum spacing requirements permitted by installation standards or the performance requirements of the system. Relocation can also result in sprinklers protecting areas beyond the maximum permitted protection area of coverage



of the installation standard. Tamper-resistant screws and features have been included in many products as part of the listings and labels. Tabs or other features are required to be affixed to the flexible sprinkler hose fitting or ceiling to caution against relocation of sprinklers. NFPA 13 requires a warning label limiting relocation of the sprinkler to be provided on anchoring components (brackets). The QFPE should review and inspect the installation of flexible sprinkler hose fittings to confirm sprinklers are located where shown on the contract drawings and labels are provided on brackets.

*This Page Intentionally Left Blank*

## CHAPTER 3 DESIGN

### 3-1 INTRODUCTION.

This chapter describes design-related variables which may be encountered in the field during installation. Some of these include the equivalent length that should be used in the hydraulic calculations to maintain a balanced system, the allowable number of bends, minimum bend radius, and support of flexible sprinkler hose fittings.

#### 3-1.1 CONUS Projects.

Flexible sprinkler hose fittings are permitted for use in CONUS projects when approved by the Designated Fire Protection Engineer (DFPE) in accordance with UFC 3-600-01. Requirements of the IBC and NFPA 13 apply to CONUS projects. For residential projects, flexible sprinkler hose fittings are permitted for use in accordance with NFPA 13D, *Standard for the Installation of Sprinkler Systems in One- and Two-Family Dwellings and Manufactured Homes*, or NFPA 13R, *Standard for the Installation of Sprinkler Systems in Low-Rise Residential Occupancies*, when permitted by UFC 3-600-01.

In accordance with the IBC, use of flexible sprinkler hose fittings for areas subject to seismic events is considered a best practice. NFPA 13 requirements are limited to hanging and support of flexible sprinkler hose fittings, permitted omission of oversized openings in seismic applications, and information required on working drawings. All other design and installation requirements are specified by the manufacturers.

#### 3-1.2 OCONUS Projects.

Flexible sprinkler hose fittings are permitted for use in OCONUS projects when approved by the DFPE in accordance with UFC 3-600-01. Requirements of local codes and standards apply to OCONUS projects. For residential projects, flexible sprinkler hose fittings are permitted for use in accordance with NFPA 13D or NFPA 13R, or local residential sprinkler standard when permitted by UFC 3-600-01. All other design and installation requirements are specified by the manufacturers.

### 3-2 THE DESIGN PROCESS.

The design process for flexible sprinkler hose fittings includes five (5) primary steps which can be expanded or modified:

1. Seeking DFPE approval for use of flexible sprinkler hose fittings.
2. Identification of the use or application for the flexible sprinkler hose fitting.
3. Identification of design performance requirements resulting in selection of design parameters.
4. Selection of a manufacturer, product, and model number.
5. Preparation of design documents.

See Appendix A for a representative design process flow chart.

### **3-3 APPROVAL TO USE FLEXIBLE SPRINKLER HOSE FITTINGS.**

The first step in the design process should include confirmation from the DFPE that flexible sprinkler hose fittings are permitted for use. When designed and installed by trained installers in accordance with the manufacturer's instructions, these products shorten installation time to meet aggressive schedules and lessen coordination issues with ceiling installations. Use of flexible sprinkler hose fittings is permitted in both CONUS and OCONUS DoD facilities only when approved by the DFPE in accordance with UFC 3-600-01.

The design professional (QFPE) should contact the DFPE to request use of flexible sprinkler hose fittings during the development of engineering design documents. This responsibility can be shared with or deferred to the sprinkler system installation contractor if the engineering design documents are performance-based or developed as part of a design-build project. It is important for the installation contractor to acknowledge that manufacturer's training to use the specific product specified for use in the project has been provided for installers. Provide certificates for each installer.

The request should be made using a request form or Request for Information (RFI) so that approval for use can be documented and included in the quality control (QC) process. See Appendix B for a sample request form.

### **3-4 USE OR APPLICATIONS.**

Installation uses or applications include but are not limited to:

- Acoustic ceiling tile ceilings.
  - Center-of-tile applications. Most common in DoD applications.
  - Quarter-point applications. Not common in DoD applications.
- Gypsum board (hard lid) ceilings.
- Sidewall sprinkler applications.
- Clean rooms.
- Industrial ducts.
- Institutional applications, such as briggs, prisons, and psychiatric wards. Products should be reviewed by Security Forces personnel.
- Walk-in freezers and coolers.
- Dry systems.
- Localized areas requiring dry sprinklers.
- Seismic areas.
- Specialty applications.

### 3-4.1 Acoustic Ceiling Tile Ceilings.

Flexible sprinkler hose fittings are ideal for installation in buildings with ceilings using acoustic tiles. As with any installation, provide adequate space above the ceiling to allow for installation of the sprinkler system piping and flexible sprinkler hose fittings with mounting brackets. The brackets allow for easy installation and adjustment to achieve center-of-tile or quarter-point installation of sprinklers. Brackets are attached to the ceiling grid members by latching clips and/or screws. Center-of-tile applications are normally specified for DoD facilities.

Inconsistencies in ceiling height can also be easily overcome without the need for cut-back or major pipe modifications. Reducers can be sized to accommodate a variety of adjustments. Markings and tamper-resistant features are provided to restrict undesired movement of the sprinklers after the system has been accepted. Connections on dry pipe and preaction sprinkler systems are typically at the top of the branch line. Connections on wet pipe and deluge sprinkler systems can be at the top, side, or bottom of the branch line.

However, best practice is to limit connections to the top and side of the branch line.

**Figure 3-1 Center-of-Tile Installation Using a Flexible Sprinkler Hose Fitting (Courtesy of Victaulic)**

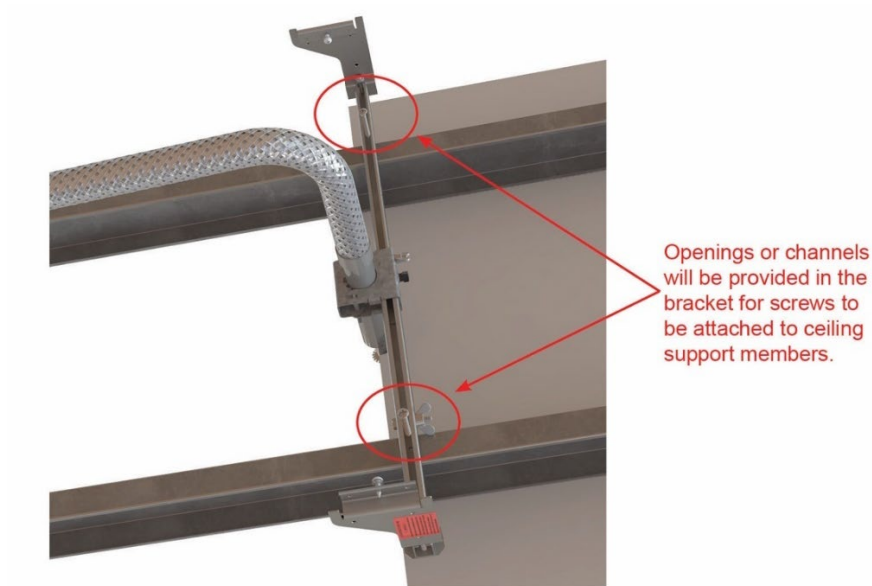


### 3-4.2 Gypsum Board (Hard Lid) Ceilings.

Universal brackets and special application brackets allow for installation of flexible sprinkler hose fittings above hard-lid ceilings. The brackets are attached to the top side of the ceiling support members.

These brackets can be used with wood or metal studs in ceilings when identified in the manufacturer's installation instructions as being reviewed by the approval agency as part of a listing.

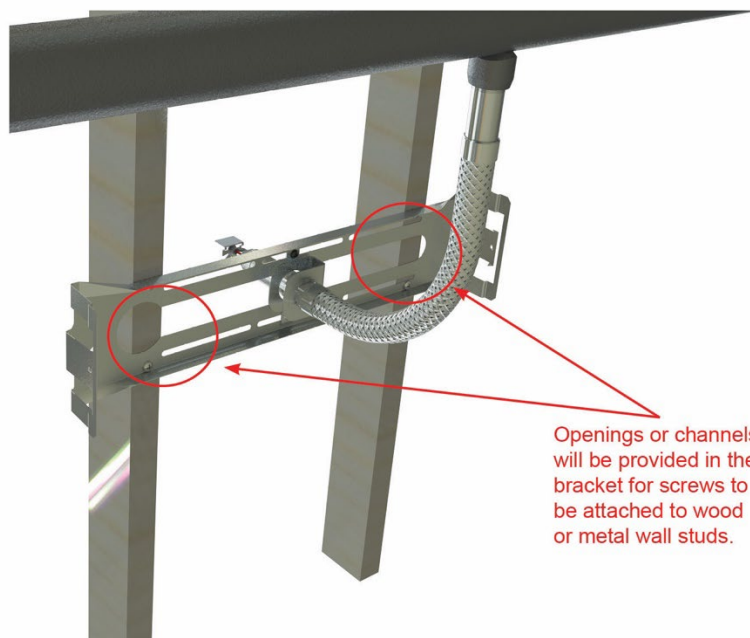
**Figure 3-2 Hard Lid Ceiling Installation Viewed from Above the Ceiling  
(Courtesy of ASC)**



**3-4.3 Sidewall Applications.**

Universal brackets and special application brackets also allow for installation of flexible sprinkler hose fittings to wood or metal studs in walls. The brackets are attached to the back side of the studs.

**Figure 3-3 Sidewall Sprinkler Installation  
(Courtesy of ASC)**



### 3-4.4 Clean Rooms.

Special listed flexible sprinkler hose fittings are available for use in clean rooms. These flexible sprinkler hose fittings are designed and approved with specific clean room ceiling manufacturers' ceiling systems identified in the listings.

### 3-4.5 Industrial Ducts.

Special listed flexible sprinkler hose fittings are available for use in industrial ducts and paint spray exhaust ducts. Flexible sprinkler mounting blocks attach directly to round or rectangular ducts and are designed to allow for the sprinkler or protective bag to be easily inspected or replaced. Options are available for metal, PVC (polyvinyl chloride), CPVC (chlorinated polyvinyl chloride), FRP (fire resistant plastic), and polypropylene ducts. The flexible hose accommodates for vibration and movement of the ducts without damaging the sprinkler or piping.

**Figure 3-4 Industrial Duct Sprinkler Installation on Round Duct  
(Courtesy of Victaulic)**



**Figure 3-5 Duct Mounting Block with Poly Bag Assembly  
(Courtesy of TERPconsulting)**



### **3-4.6 Institutional Applications Such as Brigs, Prisons, and Psychiatric Wards.**

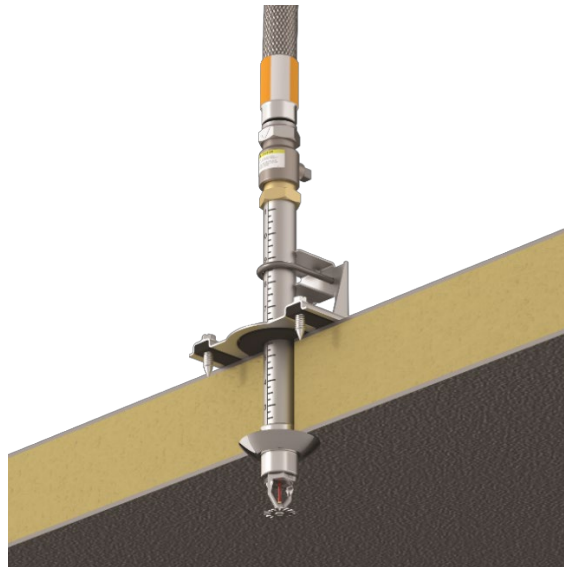
Special application brackets or hub assemblies are designed for use with concrete and masonry block wall and ceiling construction. This allows for the reducer to be installed through the wall or ceiling and is restrained by the locking hub attached (screwed using masonry anchors) to the back side of the wall. Selected flexible sprinkler hose fittings, brackets and design information should be reviewed by Security Forces as part of the approval process.

### **3-4.7 Walk-in Freezers and Coolers.**

Dry pendent assemblies suitable for use in wet pipe sprinkler systems or dry pipe sprinkler systems are available. Use of a flexible sprinkler hose fitting allows the assembly to flex with the structure. One of the benefits of using a flexible sprinkler hose fitting for a freezer application is that the flexible hose allows for movement of the walkable ceiling, preventing any sealant from cracking and causing air leaks that lead to condensation and eventual failure. Bracket assemblies are designed to allow for easy cutting and installation in freezers and walk-in coolers. The reducer is sized for connection of a dry barrel sprinkler and allows for easy replacement or removal for testing in accordance with UFC 3-601-02, *Fire Protection Systems Inspections, Testing, and Maintenance*, and NFPA 25, *Standard for the Inspection, Testing, and Maintenance of Water-Based Fire Protection Systems*.



**Figure 3-6 Walk-in Cooler Installation  
(Courtesy of Victaulic)**



**Figure 3-7 Flexible Sprinkler Hoses with Dry Pendent Sprinklers  
(Courtesy of ASC)**



### **3-4.8 Dry Systems.**

Use of pendent and sidewall sprinklers in dry pipe systems is limited by NFPA 13 and other installation standards. Dry sprinkler models are available for use in dry pipe sprinkler systems and localized areas requiring dry sprinklers. These systems are dry through the entire assembly, from connection fitting to the branch line. Collection of water in the flexible hose is not possible, therefore eliminating corrosion and freeze concerns in the drops.

### 3-4.9 Localized Areas Requiring Dry Sprinklers.

The dry sprinkler models can be used to supply pendent or sidewall sprinklers to be installed for localized protection against freezing. The flexible hose can be used to extend the distance between the water-filled piping and the cold environment, providing better protection against freezing.

**Figure 3-8 Dry Pendent Sprinkler Installation  
(Courtesy of Victaulic)**



### 3-4.10 Seismic Areas.

Use of flexible sprinkler hose fittings in seismic areas has been found to reduce sprinkler damage. Differential oscillation of the sprinkler system piping trails the movement of the structure. This effect often results in channeling of the ceilings caused by the sprinkler drop moving at a different rate from the ceiling. Upward movement can cause the sprinklers to be damaged by the ceiling, released during non-fire conditions, or be lodged above the ceiling. Use of a flexible sprinkler hose fitting allows the sprinkler to move with the ceiling, accommodating for differences between the motion of the structure and the sprinkler piping. This limits potential damage and eliminates the need for having an oversized opening around the sprinkler penetrations through the ceiling. Actual field experience during earthquakes has made flexible sprinkler hose fittings a best practice application in seismic areas.

Flexible sprinkler hose fittings can be used to provide flexibility in areas where structural movement or variations are possible. For example, structural movement has been observed in areas where clay soil caused displacement of sprinkler escutcheons.

**Figure 3-9 Ceiling Damage Caused by Earthquake  
(Courtesy of Accel Fire Protection)**



**Figure 3-10 Concealed Sprinkler Damaged by Earthquake  
(Courtesy of Accel Fire Protection)**



#### **3-4.11 Specialty Ceiling Applications.**

Special flexible sprinkler hose fittings are available and listed for specific specialty ceiling systems designed to provide specific locations for sprinklers and other features.

**Figure 3-11 Special Application Sprinkler and Ceiling Installation  
(Courtesy of ASC)**



### **3-5 FLEXIBLE SPRINKLER HOSE FITTING PERFORMANCE REQUIREMENTS.**

#### **3-5.1 Flexible Sprinkler Hose Designs.**

There are multiple flexible sprinkler hose fitting design options that have varying levels of performance. Flexible sprinkler hoses can be braided or unbraided, with either helical or annular corrugated tubing. Flexible sprinkler hoses are limited to a maximum number of bends and bend radii per their listing.

##### **3-5.1.1 Corrugated Hose.**

A corrugated flexible sprinkler hose is made by forming corrugation on either seamless or welded sheet stainless steel tubing. The corrugations are either formed in a helical pattern or an annular pattern. The different patterns affect the flexibility, durability, and strength of the hose. The design is selected by the manufacturer for different purposes and is not necessarily selected by the design team.

###### **3-5.1.1.1 Helical Pattern.**

The helical corrugation pattern provides durability and strength, but limits flexibility, requiring larger bend radii.

###### **3-5.1.1.2 Annular Pattern.**

The annular corrugation pattern provides flexibility, but strength and durability can be reduced. The number of corrugations per unit length will determine the strength and flexibility of the hose. A higher number of corrugations will increase flexibility and hose

expansion. A lower number of corrugations will increase the strength of the hose but result in the hose being stiff and more susceptible to kinking.

### 3-5.1.2 Braided Hose.

An outer layer of braided stainless steel is added over the inner corrugated hose. The purpose of the braided outer layer is to increase strength and durability. The tendency for kinking is also lessened. All FM-approved (listed) products have outer braiding. UL-certified (listed) products include both braided and unbraided options. Other listing agencies also include both braided and unbraided options. Flexible sprinkler hose fitting products should be limited to braided options only. Braiding mesh density can be modified by the manufacturer to change the strength, durability, and pressure rating.

**Figure 3-12 Braided Sprinkler Hose  
(Courtesy of ASC)**



**Figure 3-13 Standard and High-Pressure Braiding  
(Courtesy of TERPconsulting)**

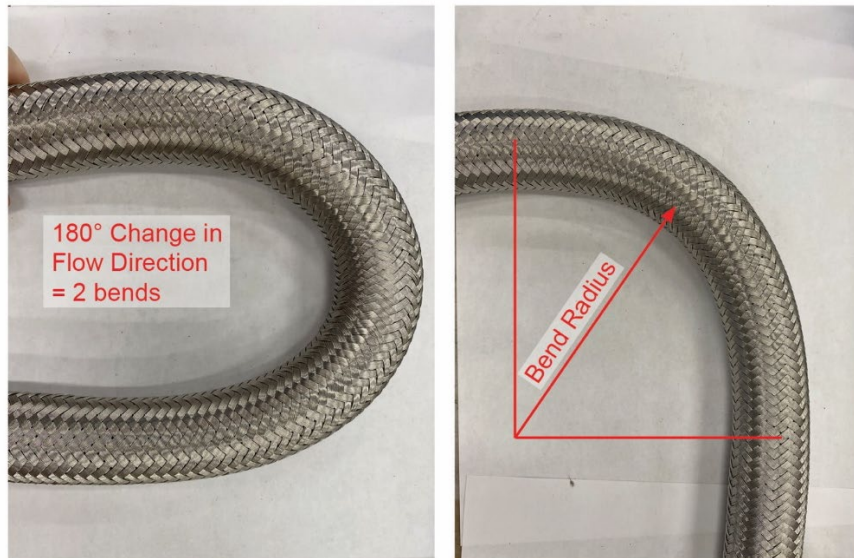


### 3-5.2 Bend Radius.

The bend radius is identified as part of the listing for each individual flexible hose. Braided hoses will typically have a smaller bend radius, such as 2 inches, whereas an equivalent unbraided hose might be 4 inches. Each flexible hose will have an identified minimum bend radius so there is no universally applied radius for all hoses. Each 90° change in flow direction (turn) is considered a bend. Where a flexible hose is configured to have a change in flow direction of 180°, it would be considered to have two (2) bends.

Bend radius varies based on testing for limited flexibility (2 inches to 4 inches) or high flexibility (7 inches or more). Annular hose designs (2 inches to 3 inches) have a tighter minimum bend radius than helical hose designs (3 inches to 4 inches).

**Figure 3-14 Example of Bend Radius and Multiple Bends  
(Courtesy of TERPconsulting)**



### 3-5.3 Number of Bends.

The number of permitted bends is also specific to each individual flexible sprinkler hose fitting and whether it is listed for limited flexibility or high flexibility. In some cases, braided models will permit a significantly higher number of bends, such as eight versus three, for an equivalent unbraided model. Each flexible sprinkler hose fitting will have an identified maximum number of bends, so there is no universally applied number for all models. **Note:** The number of permitted bends will differ based on the listing test standard used. For example, the same flexible sprinkler hose fitting might have a different number of permitted bends on the UL and FM listings.

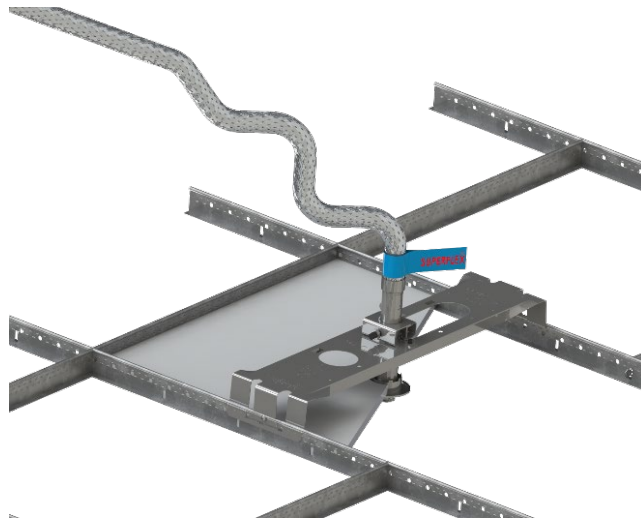
UL 2443 allows a minimum bend radius of 2 inches, with a minimum of one (1) bend for hoses up to 2 feet long; two (2) bends for a 3-foot hose; and three (3) bends for hoses longer than 3 feet. Products are either listed for limited flexibility or high



flexibility. Per UL 2443, flexible hose fittings having high flexibility are fatigue tested for 50,000 cycles of repeated flexing; flexible hose fittings having limited flexibility are fatigue tested for 100 cycles.

FM 1637 allows a minimum of one (1) bend for hoses up to 2 feet long; two (2) bends for hoses 2 to 3 feet long; three (3) bends for hoses 3 to 4 feet long; and four (4) bends for hoses 4 to 6 feet long. All flexible sprinkler hose fittings are fatigue tested for 50,000 cycles of repeated flexing.

**Figure 3-15 Bends in a Flexible Sprinkler Hose  
(Courtesy of ASC)**



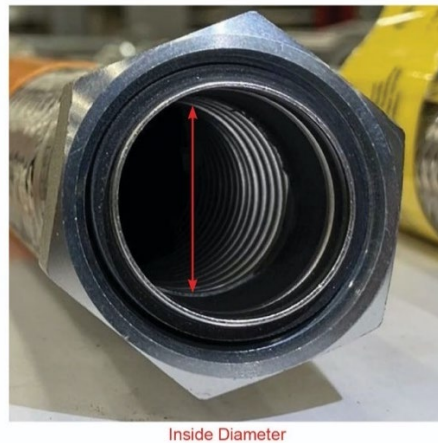
### **3-5.4 Diameter and Equivalent Length.**

The diameter of the inner corrugated hose impacts the strength and hydraulic performance of the hose. A smaller hose can be used to limit elongation forces which increases equivalent length (friction loss) due to the smaller hydraulic diameter. A larger hose will result in reduced friction loss due to the increased hydraulic diameter. The user does not need to be concerned with these issues, since the manufacturers select hose sizes to meet the performance needs of a given product.

The equivalent length being used in the hydraulic calculations will also vary based on the number of bends used. Specify the number of bends used in the design on the drawings, in the hydraulic calculations, and the QC form, or the friction loss based on the maximum number of bends should be applied. It is good practice to identify a discrete number of bends to be used for the installation.

Using the friction loss based on the maximum number of bends will overestimate friction loss if fewer bends are used. Flexible sprinkler hose fittings for wet pipe sprinkler system applications are available that are UL-listed and FM-approved as a K-5.6 sprinkler, such that the equivalent length is zero feet.

**Figure 3-16 Inside Diameter of Hose  
(Courtesy of TERPconsulting)**



### **3-5.5 Branch Line Adapters.**

Branch line adapters are end fittings used to connect the flexible hose to the sprinkler system branch line. The end fittings will have different connection types on the end connecting to the branch line and to the flexible hose on the other end. The connection to the branch line can be threaded, welded, or grooved. The other end of the fittings can be either a threaded or grooved type. Branch line adapters with threaded connections can result in residual torque to the flexible hose from rotation during installation, impacting the performance of the hose. Branch line adapters with grooved type connections can be more easily adjusted to relieve residual torque. In most instances, flexible sprinkler hose fittings have hose threads specific to the individual product lines offered by the various manufacturers. In some cases, manufacturers might also use proprietary grooves.

**Figure 3-17 Branch Line Adapters  
(Courtesy of ASC)**



### **3-5.6 Reducers.**

Reducers are end fittings that allow transition from a larger diameter hose to a smaller diameter sprinkler. Reducers are available in straight and angled configurations.



Reducers can vary in length and the effect on equivalent length is usually minimal. Reducers are also used to provide a mounting interface to brackets and have incremental markings for setting sprinkler elevations relative to the ceiling or wall. Elbow reducers are typically used in applications with tight ceiling spaces.

**Figure 3-18 Angled and Straight Reducers  
(Courtesy of TERPconsulting)**



### **3-5.7 Connection to Hose.**

Connections to the hose can either be union type (adjustable) or fixed type using a welded connection. Ensure the distance between the union connection and the start of the braided hose is a maximum of 2 inches.

Fixed connections have a welded connection between the collar and the end fitting. Fixed connections are typically not available on unbraided models. An advantage of the fixed connection is that a potential leak point is eliminated. A disadvantage of the fixed connection is the potential for residual torque if the flexible hose is restrained while being installed or while attempting to achieve proper sprinkler alignment with the ceiling. Fixed connections can be difficult in tight spaces and require installation with either an elbow branch line adapter or elbow reducer connection.

**Figure 3-19 Comparison of Welded and Adjustable Reducers for Connections of Sprinklers to The Flexible Hose (Courtesy of TERPconsulting)**



Some products have limitations on how close the installer can bend the hose to the union on either end of the hose. Such the one having a manufacturer's warning label shown in this figure.

Union (adjustable) connections use a union (nut and gasket) to connect the collar to the end fitting. Adjustable connections typically have a plastic spacer (gasket) which acts as a dielectric separation between the stainless-steel hose and the carbon steel nut. Use of the union reduces the potential to develop residual torque which can be experienced with fixed connections. The union will also add to ease of installation in tight spaces. The quality of these connections can vary; lower-quality connections can cause leaks.

**Figure 3-20 Union Connections to Hose (Courtesy of TERPconsulting)**

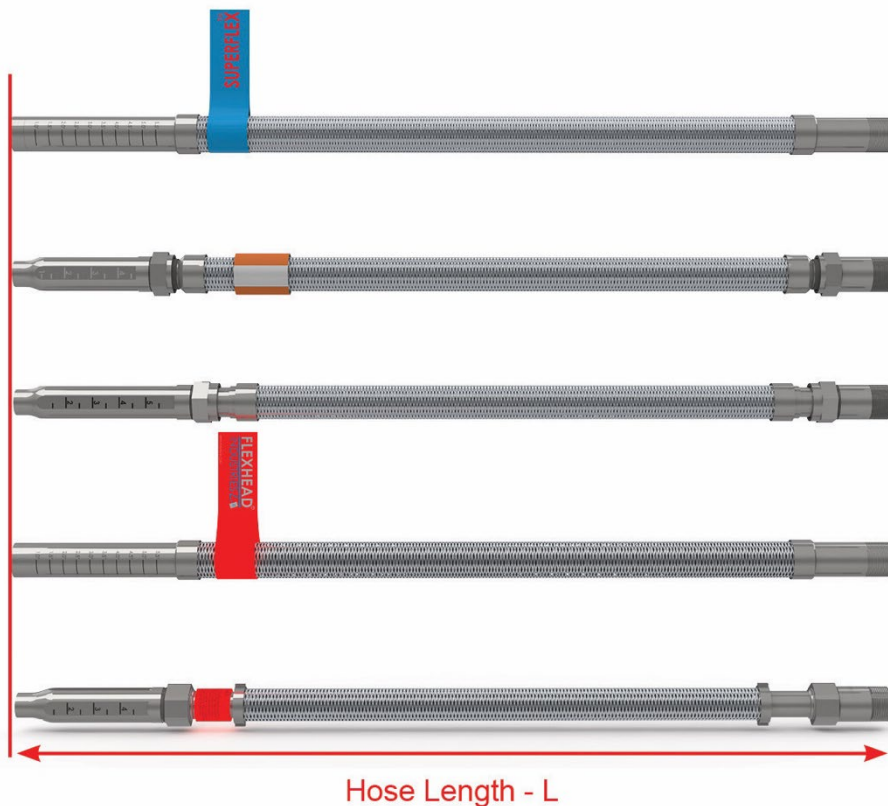


### 3-5.8 Length.

Flexible sprinkler hose fittings are manufactured in lengths up to 6 feet, since both UL 2443 and FM 1637 limit flexible sprinkler hose fittings to 6 feet in length. Shorter lengths have a limited number of bends, so are less versatile. Longer lengths introduce the opportunity for inappropriate relocation, affecting sprinkler system layouts by exceeding the maximum spacing used. Ideally, a flexible sprinkler hose fitting length of 4 feet should be used. This provides adequate workability and flexibility for ceiling adjustments and limits potential for inappropriate relocation of sprinklers. Longer lengths can use hard-piped arm-overs or drops to connect to the flexible sprinkler hose fittings.

The length of a flexible sprinkler hose fitting is measured from the end of the branch line adapter to the end of the reducer and not simply the flexible hose itself. Flexible sprinkler hose systems in OCONUS installations should not be permitted to exceed 6 feet without approval of the Component Fire Protection Engineer (CFPE) as defined in UFC 3-600-01.

**Figure 3-21 Sprinkler Hose Length  
(Courtesy of ASC)**



### 3-5.9 Brackets.

Ensure mounting brackets are UL 2443-listed and FM 1637 approved for the ceiling type in use. Ensure brackets for flexible sprinkler hose fittings meet NFPA 13

requirements for restraint against upward movement for sprinkler systems having a maximum working pressure greater than 100 pounds per square inch with pendent sprinklers positioned below ceilings.

Brackets are used to support the flexible hose system and attachment to the ceiling or structure. Brackets must be listed and approved as part of the flexible hose fitting for attachment to the ceiling, wall, or other surface. Some brackets have a universal design which is listed and approved to be used for attachment to a variety of construction types and applications. Other brackets are limited to specific ceiling types or applications. Ensure design of center brackets prevents tampering from other trades.

Brackets provide an anchor between the ceiling or structure and the flexible hose end fitting. The attachment of the end fitting can be made through a closed or open arrangement.

### **3-5.9.1 Closed or Closed Gate Attachments.**

Closed or closed gate attachments are made by inserting the end fitting through a closed attachment to the assembly bracket. The closed gate attachments require that the bracket and assembly be aligned with the opening in the ceiling for the sprinkler prior to installation of the flexible hose. Once the fitting is installed and set, a set screw is typically used.

### **3-5.9.2 Open or Open Gate Attachments.**

Open or open gate attachments are made by inserting the end fitting into an open attachment to the assembly bracket. The open center hub allows the sprinkler to be installed on the flexible sprinkler hose fitting before connecting the fitting to the branch line. This design adds flexibility during installation, since the flexible hose can be installed prior to installing the ceiling and bracket. The open gate attachment can be adjusted to allow alignment between the ceiling and sprinkler.

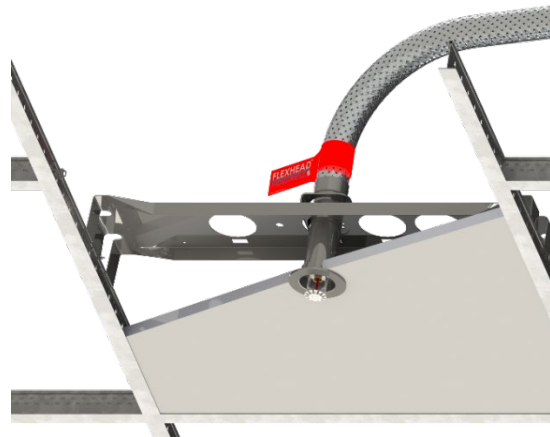
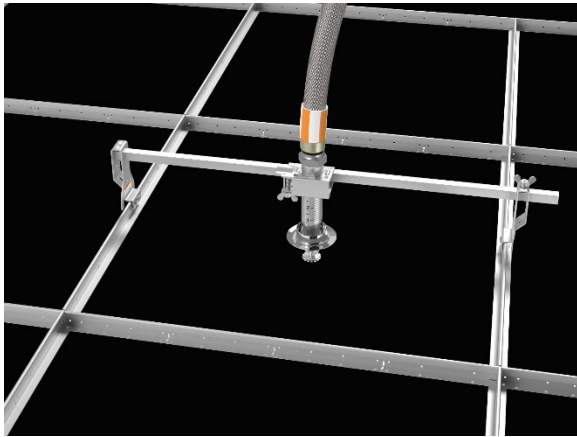
### **3-5.9.3 Mounting Blocks and Hubs.**

Mounting blocks are used for attachment of flexible sprinkler hose fittings to ducts, and mounting hubs are used for attachment to block walls for institutional sprinklers. For hoses up to and including 6 feet in length, the bracket, mounting block, or hub will be the only support required. For flexible hose lengths exceeding 6 feet in length, additional hangers are required every 6 feet. Since hose lengths are limited to 6 feet for both CONUS and OCONUS applications (unless specifically approved by the CFPE per UFC 3-600-01), this does not normally apply.

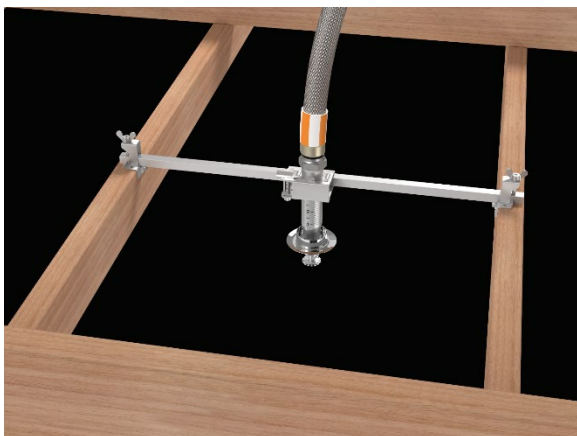
**Figure 3-22 Open Gate Attachment Gate or Hub  
(Courtesy of ASC)**



**Figure 3-23 Ceiling Grid Brackets  
(Courtesy of Victaulic and ASC)**

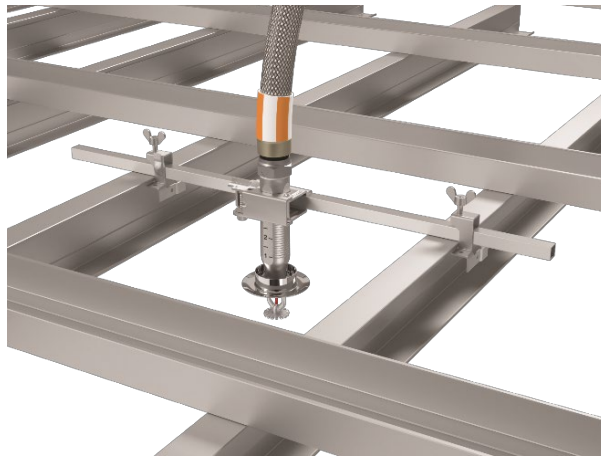


**Figure 3-24 Wood Ceiling Brackets  
(Courtesy of Victaulic)**





**Figure 3-25 Metal Ceiling Brackets  
(Courtesy of Victaulic)**



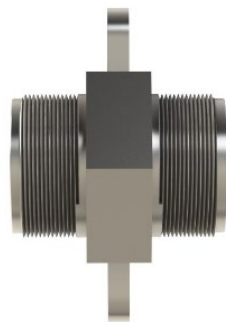
### **3-5.10 Hose Couplings.**

Hose couplings can be used to gang two (2) flexible hoses together to form a longer hose. This is not currently permitted in CONUS applications. Originally, flexible sprinkler hose fittings were made up to 12 feet in length. Concerns regarding inappropriate relocation of sprinklers following installation resulted in changes to NFPA 13 and UL 2443 to limit flexible sprinkler hose lengths to a maximum of 6 feet. FM 1637 requires all flexible sprinkler hose fittings to have end fittings that prevent interconnection of multiple assemblies to create longer hoses.

Ganging of two (2) or more hoses should not be permitted in OCONUS applications even if allowed by Host Nation installation standards. It is preferred to exclude ganging of multiple flexible hoses from DoD applications, since sprinklers can be inappropriately relocated creating non-compliance issues such as exceeding sprinkler spacing limits.

Flexible sprinkler hose systems in OCONUS installations should not be permitted to exceed 6 feet in length without approval of the CFPE as defined in UFC 3-600-01.

**Figure 3-26 Hose Coupling  
(Courtesy of ASC)**



### 3-6 SELECTION OF FLEXIBLE SPRINKLER HOSE FITTING MODEL AND HYDRAULIC PERFORMANCE.

A specific flexible sprinkler hose fitting should be selected once the application and all performance requirements have been established. Include the friction loss chart for the selected sprinkler on the shop drawings.

As an example, a 4-foot flexible sprinkler hose fitting is needed for a pendent sprinkler installed beneath a hard lid ceiling. The sprinkler system will be designed and installed using fittings and components rated for standard working pressure (maximum of 175 pounds per square inch). A k=5.6, ½-inch NPT quick response intermediate temperature (225 °F [107° C]) sprinkler is being used.

#### 3-6.1 FlexHead® Options.

When looking at flexible sprinkler hose fittings manufactured by FlexHead® (ASC), there are options for FM-approved (listed) and UL-listed options.

##### 3-6.1.1 FM-approved.

Looking first at FM-approved options, there would be eight (8) available assemblies to choose from. Table 3-1 includes letter designations indicating pressure rating options and elbow reducer options for 4-foot flexible sprinkler hose fittings. The model is expressed as 20XX, with the length in inches replacing the XX. The 4-foot length is expressed as 48". Available models are:

- 2048
- 2048E
- 2048I
- 2048T
- 2048H
- 2048HE
- 2048IA
- 2048ET

The footnotes for the table define the trailing letter designations and provide the following information:

- Model number: "H" indicates high pressure unit rated to 300 pounds per square inch.
- Model number: "ET" indicates tall elbow drop.
- Model number: "I" indicates institutional.
- Model number: "IA" indicates for institutional use with the Amerlux ceiling system.
- Model number: "T" indicates tall.
- Model number: "HE" designates high pressure elbow unit rated to 300 psi.

- FlexHead® products are intended for use in hydraulically designed wet, preaction, deluge or dry pipe sprinkler systems per NFPA 13, NFPA 13D, and NFPA 13R requirements.
- The hydraulic loss of FlexHead® should be included in the hydraulic design calculations the same as a valve or fitting.
- Bracket System MPO-24-BKT-2 has a maximum 24-inch requirement for anchoring to the building component.
- Intended for use for direct connection to fire sprinklers and has limited flexibility.

For the specified application, two (2) of the models would be appropriate: 2048 and 2048E. These would be the standard option with straight or elbow configurations. The 2048H and 2048HE options reference high-pressure models which could be used, but are not necessary since all other system components will have a standard pressure rating of 175 pounds per square inch. The 2048I and 2048IA options are for institutional applications and would not be appropriate for the specified application. The 2048T and 2048ET are tall options using taller brackets with longer reducer fittings requiring additional clearance and are not necessary for the specified application. This leaves the decision between the straight and elbow fitting options.

The friction loss for the straight option is equivalent to 30.3 feet of 1-inch schedule 40 pipe, while the friction loss for the elbow option is slightly greater, as would be expected. The elbow configuration has an equivalent length of 33.8 feet of 1-inch schedule 40 pipe. Both models are permitted to have a maximum of three (3) bends. If overall system demand pressure is not a concern, the elbow option could be appropriate, but the straight option provides a slight hydraulic advantage.

### **3-6.1.2 UL-Listed.**

Looking at the UL-listed options, there would only be three (3) available assemblies to choose from. Table 3-2 uses the same letter designations indicating pressure rating options, and elbow reducer options for 4-foot flexible sprinkler hose fittings. As with the FM-approved options, the model is expressed as 20XX, with the length in inches replacing the XX. The 4-foot length is expressed as 48". The available models are:

- 2048
- 2048H
- 2048T

There are only straight reducer options to select from the standard assembly, the high-pressure assembly, and the tall assembly options. The friction loss based on the UL listing for all these models would result in an equivalent length of 24 feet of 1-inch schedule 40 pipe based on a maximum of four (4) bends. These are the same models with FM approval, but following the UL listing requirements provides a hydraulic advantage which is based on the differences in the tests used as part of the listing



standards. Consideration can be given to using the lower friction loss where available supply pressure is a concern.

**Table 3-1 FM Approved Options for Hard Lid Applications  
(Courtesy of FlexHead®/ASC)**

<b>*FM* FLEXHEAD® FRICTION LOSS DATA</b>							
Flexhead® Model #	Outlet Size in (cm)	Hose Assembly Length Ft (m)	Maximum Number of 90-Degree Bends (Bending Radius)	Maximum Equivalent Length of Schedule 40, Nominal 1 in Diameter Pipe	Maximum Ambient Temperature Rating F / (C)	Maximum Rated Pressure psi (kPa) / psi (kPa) Standard / H-Series	Maximum K-factor & Orifice of Sprinkler K-factor/ orifice
			8"-FM	FM (ft)			
2024, 2024H	1/2 (1.27)	2 (0.6)	1	18.4	300° / (148°)	175 (1205) / 300 (2068)	5.62 / 1/2"
<del>2036, 2036H</del>		<del>3 (0.9)</del>	<del>2</del>	<del>26.6</del>			
2048, 2048H		4 (1.2)	3	30.3			
<del>2060, 2060H</del>		<del>5 (1.5)</del>	<del>4</del>	<del>35.8</del>			
2072, 2072H		6 (1.8)	4	45.6			
<del>2024, 2024H</del>	3/4 (1.90)	<del>2 (0.6)</del>	<del>1</del>	<del>14.7</del>	300° / (148°)	175 (1205) / 300 (2068)	14.0 / 3/4"
<del>2036, 2036H</del>		<del>3 (0.9)</del>	<del>2</del>	<del>21.8</del>			
2048, 2048H		4 (1.2)	3	29.0			
2060, 2060H		5 (1.5)	4	36.1			
2072, 2072H		6 (1.8)	4	43.2			
2024E, 2024HE	1/2 (1.27)	2 (0.6)	1	26.4	300° / (148°)	175 (1205) / 300 (2068)	5.62 / 1/2"
<del>2036E, 2036HE</del>		<del>3 (0.9)</del>	<del>2</del>	<del>30.1</del>			
2048E, 2048HE		4 (1.2)	3	33.8			
<del>2060E, 2060HE</del>		<del>5 (1.5)</del>	<del>4</del>	<del>37.5</del>			
2072E, 2072HE		6 (1.8)	4	41.2			
<del>2024E, 2024HE</del>	3/4 (1.90)	<del>2 (0.6)</del>	<del>1</del>	<del>14.7</del>	300° / (148°)	175 (1205) / 300 (2068)	14.0 / 3/4"
<del>2036E, 2036HE</del>		<del>3 (0.9)</del>	<del>2</del>	<del>21.8</del>			
2048E, 2048HE		4 (1.2)	3	29.0			
2060E, 2060HE		5 (1.5)	4	36.1			
2072E, 2072HE		6 (1.8)	4	43.2			
2024I, 2024IA	1/2 (1.27)	2 (0.6)	1	18.4	300° / (148°)	175 (1205) / 300 (2068)	5.62 / 1/2"
<del>2036I, 2036IA</del>		<del>3 (0.9)</del>	<del>2</del>	<del>26.6</del>			
2048I, 2048IA		4 (1.2)	3	30.3			
<del>2060I, 2060IA</del>		<del>5 (1.5)</del>	<del>4</del>	<del>35.8</del>			
2072I, 2072IA		6 (1.8)	4	45.6			
<del>2024I</del>	3/4 (1.90)	<del>2 (0.6)</del>	<del>1</del>	<del>11.6</del>	300° / (148°)	175 (1205) / 300 (2068)	14.0 / 3/4"
<del>2036I</del>		<del>3 (0.9)</del>	<del>2</del>	<del>16</del>			
2048I		4 (1.2)	3	17.9			
2060I		5 (1.5)	4	24.7			
2072I		6 (1.8)	4	28.9			
				T (ET)			
2024T, 2024ET	1/2 (1.27)	2 (0.6)	1	18.4 (26.4)	300° / (148°)	175 (1205) / N/A	5.62 / 1/2"
<del>2036T, 2036ET</del>		<del>3 (0.9)</del>	<del>2</del>	<del>26.6 (30.1)</del>			
2048T, 2048ET		4 (1.2)	3	30.3 (33.8)			
<del>2060T, 2060ET</del>		<del>5 (1.5)</del>	<del>4</del>	<del>35.8 (37.5)</del>			
2072T, 2072ET		6 (1.8)	4	45.6 (41.2)			
				T (ET)			
<del>2024T, 2024ET</del>	3/4 (1.90)	<del>2 (0.6)</del>	<del>1</del>	<del>14.7 (14.7)</del>	300° / (148°)	175 (1205) / N/A	14.0 / 3/4"
<del>2036T, 2036ET</del>		<del>3 (0.9)</del>	<del>2</del>	<del>21.8 (21.8)</del>			
2048T, 2048ET		4 (1.2)	3	29.0 (29.0)			
2060T, 2060ET		5 (1.5)	4	36.1 (36.1)			
2072T, 2072ET		6 (1.8)	4	43.2 (43.2)			

**Table 3-2 UL-Listed Options for Hard Lid Applications  
(Courtesy of FlexHead®/ASC)**

<b>* UL* FLEXHEAD® FRICTION LOSS DATA</b>							
Flexhead® Model #	Outlet Size	Hose Assembly Length	Maximum Number of 90-Degree Bends (Bending Radius)	Maximum Equivalent Length of Schedule 40, Nominal 1 in Diameter Pipe	Maximum Ambient Temperature Rating F / (C)	Maximum Rated Pressure psi (kPa) / psi (kPa) Standard / H-Series	Maximum K-factor & Orifice of Sprinkler K-factor/ orifice
			3"-UL	UL (ft)			
2024, 2024H	1/2 (1.27)	2 (0.6)	3	11	300° / (148°)	175 (1205) / 300 (2068)	5.62 / 1/2"
<del>2036, 2036H</del>		<del>3 (0.9)</del>	<del>3</del>	<del>16</del>			
2048, 2048H		4 (1.2)	4	24			
<del>2060, 2060H</del>		<del>5 (1.5)</del>	<del>4</del>	<del>29</del>			
2072, 2072H		6 (1.8)	4	35			
2024, 2024H	3/4 (1.90)	2 (0.6)	3	12	300° / (148°)	175 (1205) / 300 (2068)	14.0 / 3/4"
<del>2036, 2036H</del>		<del>3 (0.9)</del>	<del>3</del>	<del>18</del>			
2048, 2048H		4 (1.2)	4	23			
<del>2060, 2060H</del>		<del>5 (1.5)</del>	<del>4</del>	<del>29</del>			
2072, 2072H		6 (1.8)	4	32			
2024T	1/2 (1.27)	2 (0.6)	3	11	300° / (148°)	175 (1205) / N/A	5.62 / 1/2"
<del>2036T</del>		<del>3 (0.9)</del>	<del>3</del>	<del>16</del>			
2048T		4 (1.2)	4	24			
<del>2060T</del>		<del>5 (1.5)</del>	<del>4</del>	<del>29</del>			
2072T		6 (1.8)	4	35			
<del>2024T</del>	3/4 (1.90)	2 (0.6)	3	12	300° / (148°)	175 (1205) / N/A	14.0 / 3/4"
<del>2036T</del>		<del>3 (0.9)</del>	<del>3</del>	<del>18</del>			
2048T		4 (1.2)	4	25			
<del>2060T</del>		<del>5 (1.5)</del>	<del>4</del>	<del>29</del>			
2072T		6 (1.8)	4	32			

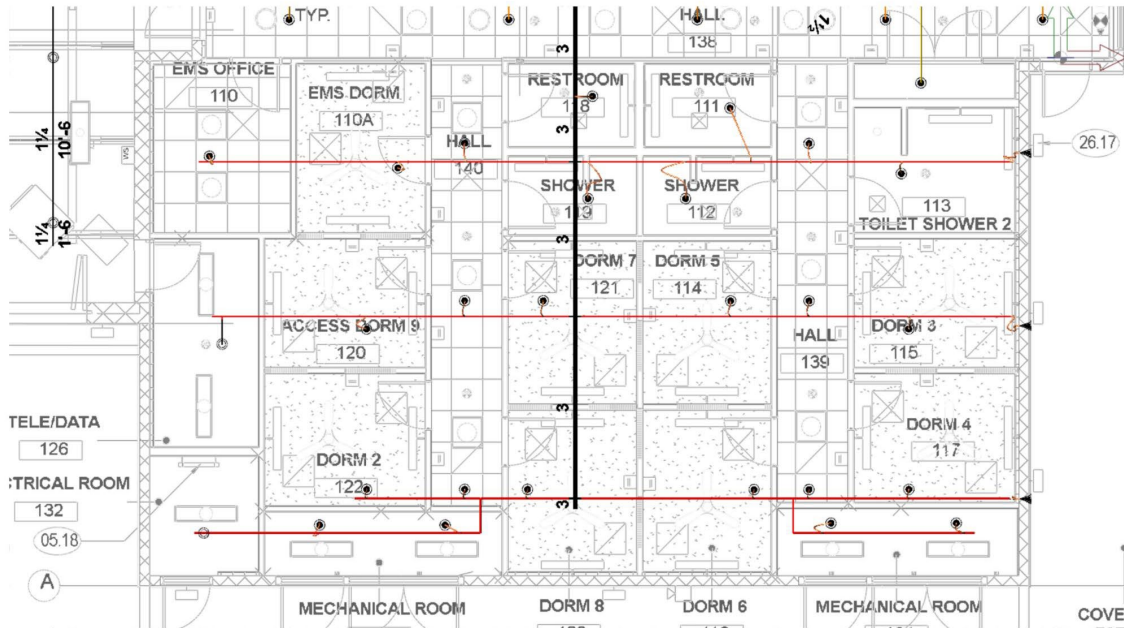
**3-7 DESIGN DOCUMENTS.**

Sprinkler system design documents should be prepared in accordance with the requirements of UFC 3-600-01 and the applicable codes and standards for the project. Design documents should include drawings, specifications, basis of design narrative, hydraulic calculations, and proposed QC form.

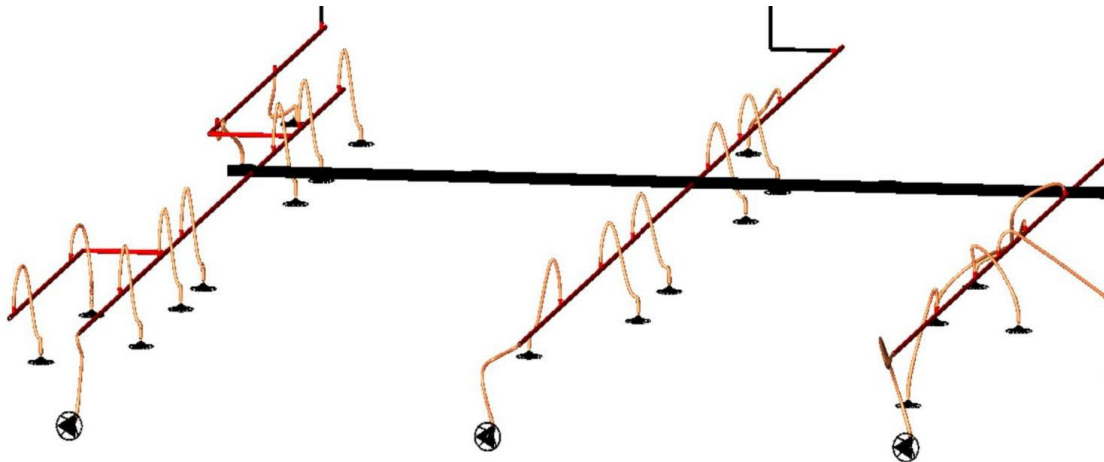
a. Information on the drawings should show the layout of systems or areas using flexible sprinkler hose fittings. The make, model, design limitations, and assumptions should be clearly identified on the shop drawings. Include the friction loss chart for the selected flexible sprinkler hose fitting on the shop drawings along with the specific sprinkler to be used in the design.

b. Information relating to the number of bends, length of hose, bend radius, types of brackets or supports should be stated on the drawing as well as the equivalent length of pipe to be included in the hydraulic calculations.

**Figure 3-27 Example Sprinkler System Layout Using Flexible Sprinkler Hose Fittings (Courtesy of TERPconsulting)**



**Figure 3-28 Example Sprinkler System Isometric Using Flexible Sprinkler Hose Fittings (Courtesy of TERPconsulting)**



c. Specifications should include reference to the flexible sprinkler hose fitting product(s) approved for the project along with performance limitations, assumptions, and requirements.

d. The design narrative should acknowledge the intent for use of flexible sprinkler hose fittings and acknowledge whether approval for use has been granted, is under consideration, or a request will be forthcoming. The design narrative should

discuss the selected flexible sprinkler hose fitting along with the listing used with corresponding friction loss, number of bends, and bend radius intended for the application.

e. Hydraulic calculations should note use of flexible sprinkler hose fittings and equivalent length used based on the performance limitations, assumptions, and requirements stated and approved for the project.

f. See Appendix C for example specification requirements for the use of flexible sprinkler hose fittings.

### **3-8 FREQUENTLY ASKED QUESTIONS REGARDING USE AND DESIGN OF FLEXIBLE HOSE FITTINGS.**

#### **3-8.1 Can Flexible Sprinkler Hose Fittings Be Used in DoD Facilities?**

Yes, but the DFPE approves use of flexible sprinkler hose fittings.

#### **3-8.2 Can Flexible Sprinkler Hose Fittings Be Used for CONUS Projects?**

Yes, if approved by the DFPE in accordance with UFC 3-600-01.

#### **3-8.3 What Codes and Standards Apply to Use of Flexible Sprinkler Hose Fittings?**

Requirements of the UFC, building code, sprinkler installation standard, and manufacturer apply.

#### **3-8.4 What Code, Standards, and Installation Requirements Apply to CONUS Projects?**

The requirements of the UFC, IBC, and NFPA 13 apply to CONUS projects. Use of flexible sprinkler hose fittings is a best practice in accordance with the IBC for areas subject to seismic requirements. Requirements in NFPA 13 are limited. Requirements primarily apply to hanging and support of flexible sprinkler hose fittings, but also include permitted omission of oversized openings in seismic applications and information required on working drawings. All other design and installation requirements are specified by the manufacturers.

#### **3-8.5 Can Flexible Sprinkler Hose Fittings Be Used for OCONUS Projects?**

Yes, if approved by the DFPE in accordance with UFC 3-600-01.

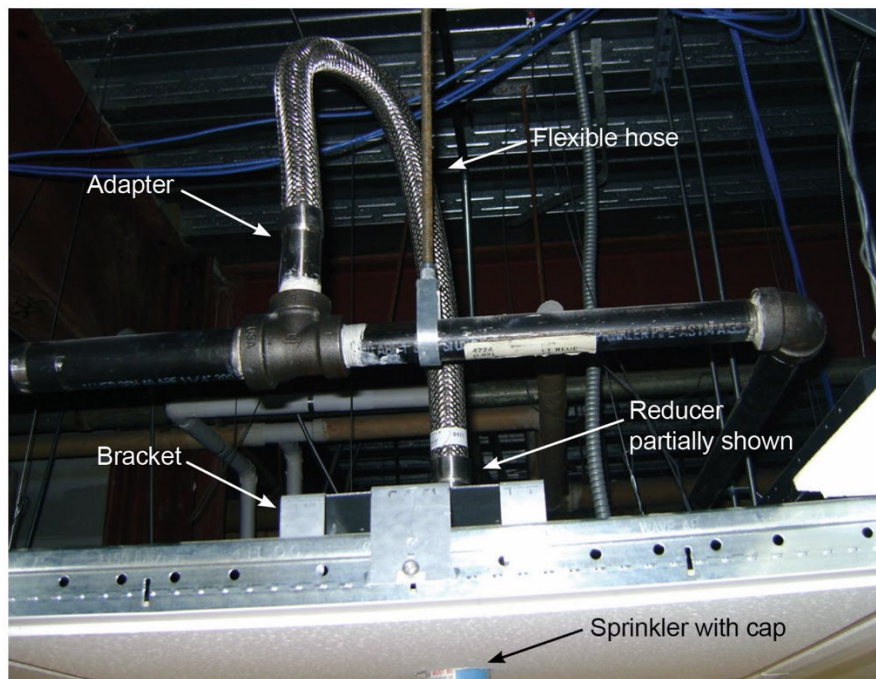
#### **3-8.6 What Code, Standards, and Installation Requirements Apply to Flexible Sprinkler Hose Fittings for OCONUS Projects?**

Host Nation codes and standards are often used in OCONUS projects. All other design and installation requirements are specified by the manufacturers. However, flexible sprinkler hose systems in OCONUS installations should not be permitted to exceed 6 feet in length without approval of the CFPE as defined in UFC 3-600-01.

### 3-8.7 What Is a Flexible Sprinkler Hose Fitting?

A flexible sprinkler hose fitting is a group of four components used to connect a sprinkler to the branch line used to supply the sprinkler. Typically, these assemblies include an integral adapter to attach to the branch line, a flexible hose, a reducer for attachment to the sprinkler, and a bracket for attachment to the ceiling assembly or structure.

**Figure 3-29 Example Flexible Hose System  
(Courtesy of TERPconsulting)**



### 3-8.8 Are Flexible Sprinkler Hose Fittings Limited to Use in Office Buildings?

No, flexible sprinkler hose fittings are listed or approved for a variety of industrial, commercial, and institutional applications. Special products are listed and approved for use in duct systems, walk-in coolers or freezers, institutional applications such as prisons, and others.

### 3-8.9 Can Flexible Sprinkler Hose Fittings Be Used in Dry Pipe Sprinkler Systems?

Yes, there are listed dry pendent and sidewall sprinklers that include a dry flexible hose as part of the assembly. These dry flexible sprinkler hose fittings can be used in dry pipe, preaction, deluge, and wet pipe sprinkler systems. There are also listed products that allow for connection to threaded dry barrel sprinkler applications for freezers and coolers and other applications where the assembly is supplied by wet pipe, preaction, or deluge sprinkler systems.

**3-8.10 What Length of Flexible Sprinkler Hose Fitting Is Permitted for Use?**

Flexible sprinkler hose fittings are permitted to be up to 6 feet in length within the U.S. Some other countries permit flexible hose lengths up to 12 feet in length. Flexible sprinkler hose systems in OCONUS installations should not be permitted to exceed 6 feet in length without approval of the CFPE as defined in UFC 3-600-01.

**3-8.11 What Type of Connection Is Used to Connect the Sprinkler Hose System to the Branch Line?**

Branch line adapters are listed for connection to male welded outlet fittings with proprietary hose threads, female welded outlet fittings, male threaded outlet fittings, female threaded outlet fittings, and grooved outlet fittings, and are specific to the products from each manufacturer.

**3-8.12 How Are Flexible Sprinkler Hose Fittings Included in Hydraulic Calculations?**

Each flexible sprinkler hose fitting is provided with an equivalent length based on product length which is included in the listing. The equivalent length is included in the hydraulic calculations.

**3-8.13 Can Flexible Sprinkler Hose Fitting Lengths Be Changed in the Field?**

No, unless revised hydraulic calculations including as-built field changes are performed to verify the water supply can meet the revised sprinkler system demand.

**3-8.14 How Many Bends Can Be Made in a Flexible Sprinkler Hose Fitting?**

The number of permitted bends is specific to each individual flexible sprinkler hose and based on its listing or approval. Each flexible hose will have an identified maximum number of bends based on the hose length (typically between three and twelve), so there is no universally applied number for all hoses. Refer to Figure 3-14 for an example.

**3-8.15 What Is the Minimum Bend That Can Be Made in a Flexible Sprinkler Hose Fitting?**

The bend radius is identified as part of the listing or approval for each individual flexible hose. Each flexible hose has an identified minimum bend radius based on the hose length (typically between 2 inches and 8 inches), so there is no universally applied radius for all hoses. Refer to Figure 3-14 for an example.

Manufacturers can provide a bend radius tool or template for installation.



**Figure 3-30 Example Bend Radius Tool on Hose With Two Bends  
(Courtesy of ASC)**



### **3-8.16 How Are Flexible Sprinkler Hose Systems Supported?**

Flexible sprinkler hose systems are supported by an attachment to the sprinkler system piping and by the bracket included as part of the product listing or approval for attachment to the ceiling or structure. In the U.S., there is no need to have any additional hangers or supports since hose lengths are limited to 6 feet. For hose lengths exceeding 6 feet, NFPA 13 requires additional hangers to ensure that the unsupported length is limited to a maximum of 6 feet. For OCONUS applications, lengths should be limited to a maximum of 6 feet so additional hangers or supports should not be necessary.

*This Page Intentionally Left Blank*



## CHAPTER 4 INSTALLATION AND INSPECTION

### 4-1 INTRODUCTION.

This chapter describes aspects of installation, inspection, and acceptance testing experienced during a project.

### 4-2 INSTALLATION.

Install flexible sprinkler hose fittings in accordance with NFPA 13, listing requirements, and manufacturer's installation instructions.

#### 4-2.1 NFPA 13.

NFPA 13 provides requirements for hanging and support of flexible sprinkler hose fittings. The first is that installation of listed flexible sprinkler hose fittings comply with the listing and manufacturer's installation instructions.

##### 4-2.1.1 Ceilings.

NFPA 13 also requires that flexible sprinkler hose fittings supported by suspended ceilings use a ceiling system that meets ASTM C635/C635M. The ceiling systems are required to be installed in accordance with ASTM C636/C636M.

##### 4-2.1.2 Hangers.

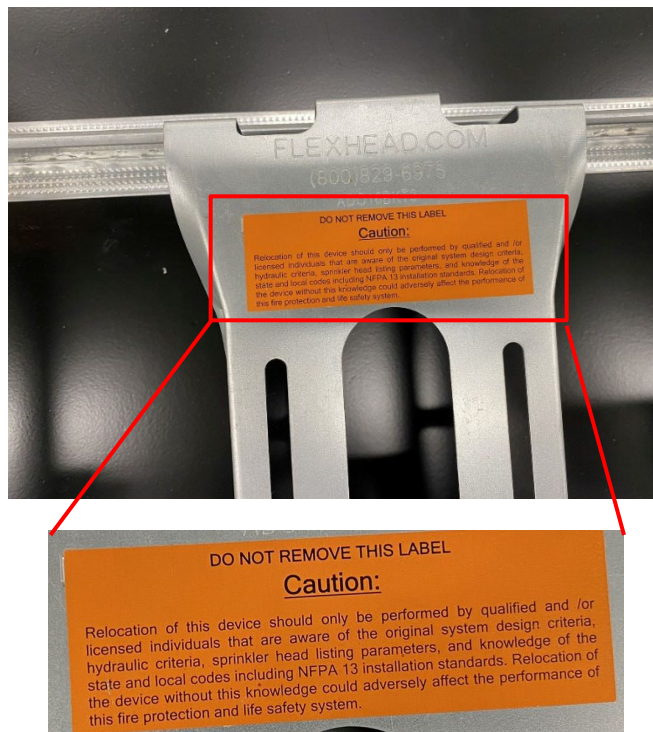
Provide hangers for flexible sprinkler hose fittings that exceed 6 feet (1.8 meters) in length if a longer length has been authorized by the CFPE as defined in UFC 3-600-01.

Use of the flexible sprinkler hose fitting with bracket meets the requirements for unsupported arm-overs with pressure exceeding 100 psi (6.9 bar). The hanger required to prevent upward movement is omitted since the required bracket is tested for this as part of the product listing.

##### 4-2.1.3 Labels.

Provide flexible sprinkler hose fittings with a warning or caution label on the bracket or anchoring component limiting relocation of the sprinkler.

**Figure 4-1 Caution Label on Bracket  
(Courtesy of TERPconsulting)**



#### **4-2.1.4 Clearance.**

As part of the seismic protection requirements for sprinkler systems, NFPA 13 requires the installed clearance between a sprinkler and structural elements used to support the sprinklers to be a least 3 inches (75 millimeters). This clearance requirement is omitted when flexible sprinkler hose fittings are used. However, the sprinklers cannot be in contact with structural members under any circumstances.

NFPA 13 requires oversized holes in areas that use suspended ceilings and are seismic design Category D, E or F to provide a larger clearance through the ceiling member. When flexible sprinkler hose fittings are used, the larger clearance requirement does not apply.

#### **4-2.2 Listing Requirements**

Requirements vary among different listing agencies. UL or FM listings require that manufacturers' instructions be included with shipment of the flexible sprinkler hose fittings. In most cases, the packaging used for shipping will include a printed copy of the manufacturer's instructions with each flexible sprinkler hose fitting. UL requires the following to be provided:

- Reference to the installation standard (NFPA 13, NFPA 13D, or NFPA 13R).

- Indication of the largest k-factor/orifice diameter sprinkler intended to be connected to the flexible sprinkler hose fitting.
- The lengths available.
- The equivalent length values.
- Instructions for connection of the flexible sprinkler hose fitting to anchoring components.
- Instructions for connection of the anchoring components to the building. This includes specific reference to ceiling constructions.
- Reference to specific installation orientation.
- Minimum bending radius.
- Pressure rating.
- Maximum temperature rating.
- Intended use in wet pipe systems, preaction systems, deluge systems, dry pipe systems.
- Maximum number of bends.
- Identification of whether the listing is for limited flexibility or high flexibility. This is based on the number of cycles used in fatigue testing.
- Nominal inlet and outlet sizes.
- Intended use for direct connection to sprinklers (most are threaded, but grooved connections are possible).
- Gasket compatibility for grooved products.
- A tool or template to verify the minimum bend radius.

FM requires that the installation instructions include special dimensional requirements and friction loss data.

#### **4-2.3 Manufacturer's Installation Instructions.**

The manufacturer's installation instructions are part of the product listing. The installation instructions for flexible sprinkler hose fittings are evaluated by the listing agency as part of the product listing. The listing agency evaluates any changes to installation instructions and may require changes to the listing.

The installation instructions will provide advisory information regarding safety and personal protective equipment (PPE) that apply to individual products.

The installation instructions will provide specific instructions for installation of the mounting brackets, connection of sprinklers, securing the bracket to the ceiling, labels, maximum number of bends, bend radius, and relocation of the sprinkler without pressure in the system.

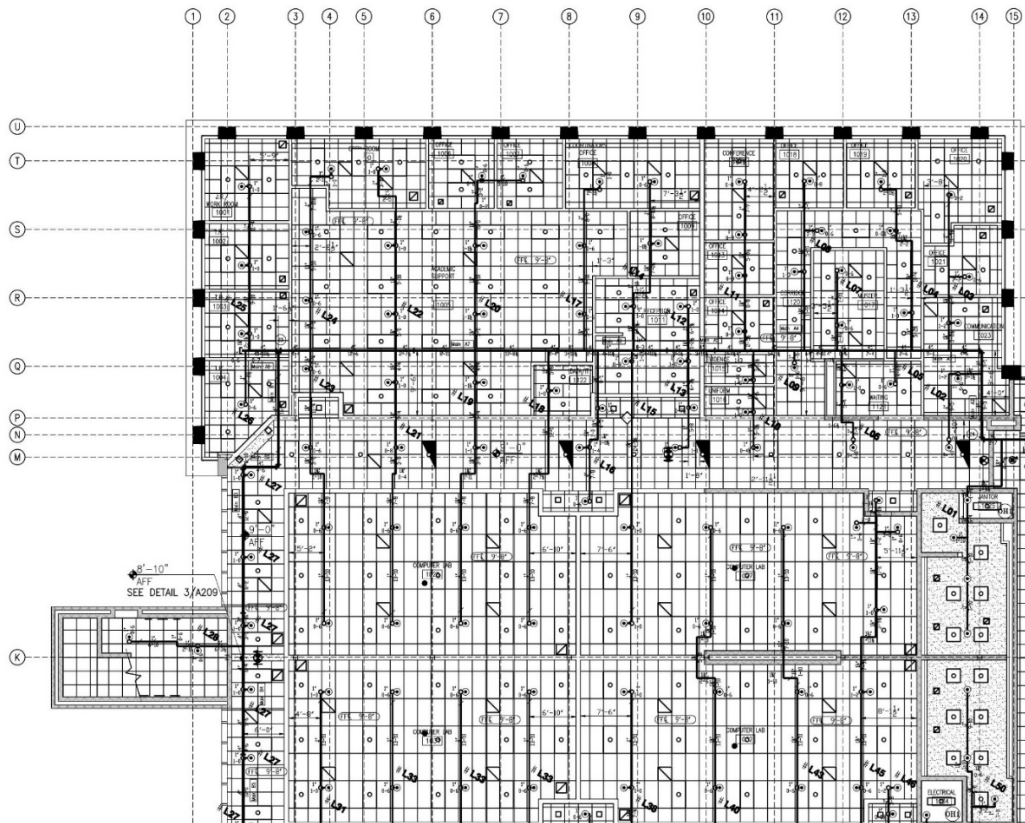
See Appendix D for an example of manufacturer's installation instructions (courtesy of ASC, FlexHead®).

### 4-3 INSTALLATION AND INSPECTIONS.

Installation of flexible sprinkler hoses follows design and approval. Center-of-tile applications are most commonly specified for DoD facilities.

As an example, the sprinkler system layout in Figure 4-2 shows flexible sprinkler hose fittings used with sprinklers installed in both center-of-tile and quarter-point configurations. The layout shows some parts of the building having 4-foot by 2-foot ceiling tiles and others having 2-foot by 2-foot ceiling tiles.

**Figure 4-2 Example Sprinkler System Layout Using Flexible Sprinkler Hose Fittings (Courtesy of TERPconsulting)**



- a. During inspection, the expectation is that sprinklers installed in the 2-foot by 2-foot ceiling tiles would be in a center-of-tile configuration, and sprinklers installed in the 4-foot by 2-foot ceiling tiles would be in the quarter-point configuration.

**Figure 4-3 Center-of-Tile Installation Using Flexible Sprinkler Hose Fittings (Courtesy of TERPconsulting)**



b. Verify the ceiling system as part of the design, installation, and quality control for the project. Ensure markings on the ceiling grid meet the requirements of the design and product listing.

**Figure 4-4 Ceiling Grid with Manufacturer's Label (Courtesy of TERPconsulting)**



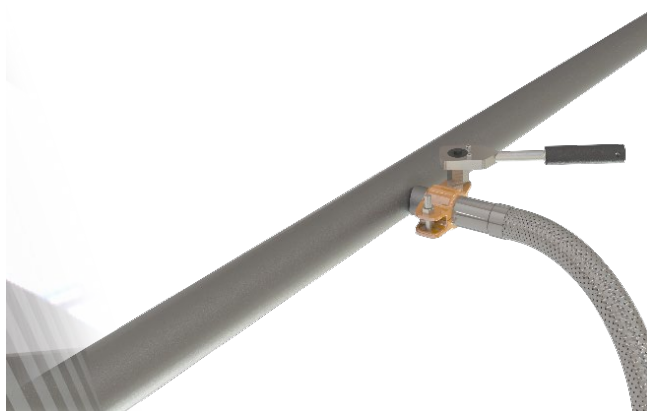
c. As with any project, rough-in inspections should confirm the location and size of main branch line and arm-over piping. The branch line and arm-over piping should be confirmed to provide the identified location for connection of the flexible sprinkler hose fittings. In most cases, the orientation should be for the branch line adapter to be connected to an outlet at the top, side, or at 45° from top. All arm-overs are positioned for installation of flexible sprinkler hose fittings from the top.

**Figure 4-5 Rough-In Installation for Flexible Sprinkler Hose Fittings  
(Courtesy of TERPconsulting)**



d. Connection type and product model should also be confirmed to match the product included in the design. Connections should be at the top or side of the branch line to prevent debris and pipe scale entering the flexible hose and settling at the sprinkler. Observation of grooved connections for this project would mean that a different model of flexible sprinkler hose fitting is being used. Substitution of products would require approval and verification, since the number of bends, bend radii, and friction loss vary among products.

**Figure 4-6 Flexible Sprinkler Hose Fitting with Grooved Branch Line Adapter  
(Courtesy of ASC)**



e. The flexible sprinkler hose fitting should be verified for the number of bends and length. If the length differs from the layout drawings, the sprinkler system demand will be different than the approved design and use for the project. Re-



evaluation of the design would be required, or components should be replaced based on the quality control program used.

**Figure 4-7 Example Flexible Sprinkler Hose Fitting  
(Courtesy of TERPconsulting)**

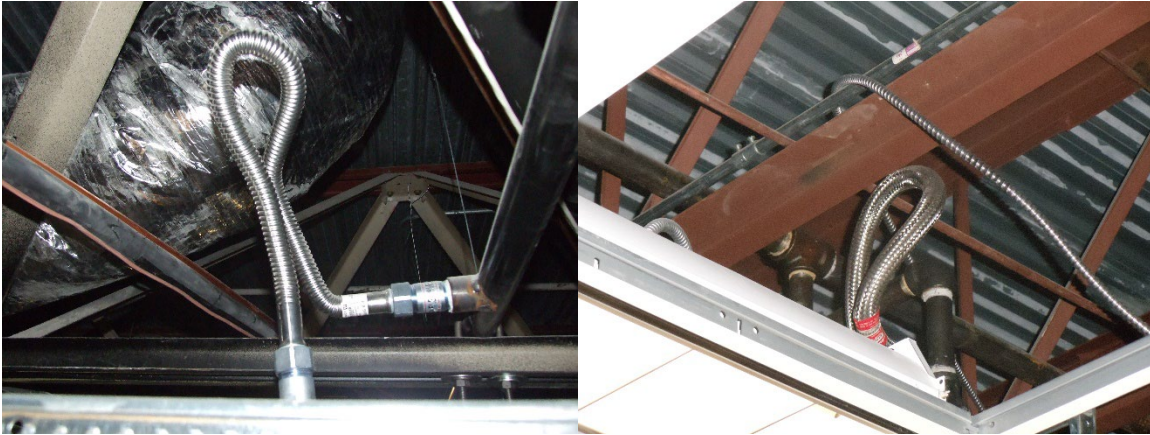


f. The flexible hose should also be verified to be free of kinking. Bending the hose too close to the connectors or with a bend radius that is less than the minimum permitted can result in kinking.

**Figure 4-8 Kink or Shallow Bend in Flexible Hose  
(Courtesy of Ralph K. Foster, III, PE, FSFPE)**



**Figure 4-9 Unbraided and Braided Hose with Bends Not Meeting the Minimum Radius  
(Courtesy of Ralph K. Foster, III, PE, FSFPE)**



g. The bracket used and attachment to the ceiling should be verified. The bracket is part of the listing for the individual flexible sprinkler hose fitting. Substitutions are not permitted.

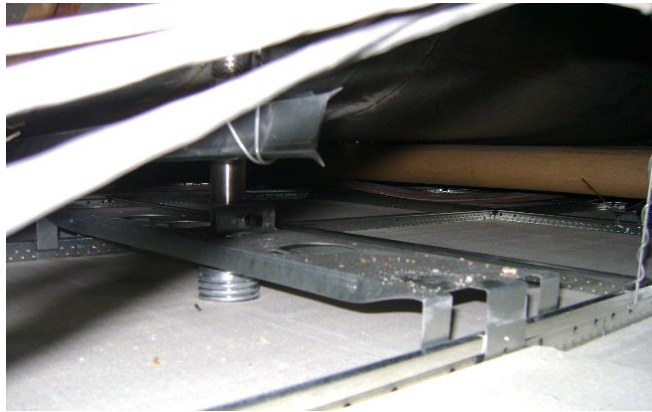
**Figure 4-10 Example Bracket with Label  
(Courtesy of Victaulic)**



h. Any tamper-resistant features should also be verified. This includes tamper-resistant screws, labels, and any other features identified by the manufacturer.



**Figure 4-11 Bracket with Tamper-Resistant Screw Installed in Ceiling Grid**  
(Courtesy of TERPconsulting)



i. Achieving the desired outcome to have sprinklers installed in a center-of-tile configuration can be easy even if changes are made to ceiling tile layout or elevation.

**Figure 4-12 Finished Center of Tile Installation**  
**Using Flexible Sprinkler Hose Fittings**  
(Courtesy of TERPconsulting)



*This Page Intentionally Left Blank*

## CHAPTER 5 QUALITY ASSURANCE

### 5-1 INTRODUCTION.

This chapter provides guidance for the approving authority in the review of submittals, approving components for use, and the inspection of system installations.

### 5-2 APPROVAL OF COMPONENTS.

Use of flexible sprinkler hose fittings requires approval by the DFPE per UFC 3-600-01. It is the responsibility of the QFPE or Fire Protection Contractor (FPC) to submit a request for approval for use of flexible sprinkler hose fittings for a specific project. An example request form is provided in Appendix B and can be used for this purpose.

a. Approval for use of flexible sprinkler hose fittings should be documented as part of a quality assurance checklist. This is also part of the project commissioning required when using NFPA 3, *Standard for Commissioning of Fire Protection and Life Safety Systems*. The quality assurance (QA) checklist should include the manufacturer, model number, length, and other specific data necessary to identify the product requesting approval for use. Approval or disapproval should be recorded on the QC checklist.

b. The submitted product should be verified as listed by the agency identified and for the application identified for the project. Both UL and FM listings of counterfeit products should be reviewed for OCONUS applications.

c. Installers should be trained by the manufacturer in use of the specific product to be used. Confirmation of training should be included for all installers as part of the approval and review process.

d. An example QC checklist is included in Appendix E.

### 5-3 REVIEW OF DESIGN DOCUMENTS.

If approved for use, information regarding the flexible sprinkler hose fitting should be included in the technical specifications for the project, discussed in the basis of design narrative, identified on the engineering and working (shop) drawings, and identified in the hydraulic calculations.

Documents should identify the application and where and how the flexible sprinkler hose fittings will be used, as described in paragraph 3-5.

#### 5-3.1 Design Drawing Elements.

Design drawings should include the following:

- manufacturer
- model number
- hose length

- hose diameter
- hose type (braided, annular corrugated) selected
- connection types and configuration
- ceiling and minimum requirements
- maximum number of bends
- minimum bend radius
- equivalent length
- pressure rating
- temperature rating
- sprinkler k-factor and orifice size to be attached to the flexible sprinkler hose fitting
- sprinkler located in the center-of tile where acoustic ceiling tile ceilings are used
- bracket to be used
- tamper-resistant features
- the friction loss (equivalent length) chart for the selected flexible sprinkler hose fitting along with the specific sprinkler used in the design

### **5-3.2 Minimum Design Document Criteria.**

At a minimum, the following questions should be answered “yes” during review of design documents:

- *Has the approved product been identified in the technical specifications?*  
The specifications should identify allowable manufacturers and performance requirements based on the approved use.
- *Has the approved product been discussed in the design narrative?*  
The design narrative should identify the intended application for the flexible sprinkler hose fitting, such as center-of-tile application. The design narrative should discuss performance requirements and limitations for the product, number of bends, bend radius, hose diameter, equivalent length, sprinkler k-factor to be supplied, connection types, and other relevant design features.
- *Do the engineering or working drawings show locations where flexible sprinkler hose fittings will be used?*
- *Do the drawings include installation details?*  
Details or notes should identify brackets, tamper-resistant features, connection types, hose length, maximum number of bends, and minimum bend radius to be used.

- *Do the drawings identify the specific model of product to be used, the length, connection types, hose diameter, the number of bends, pressure rating, temperature rating, and bend radius to be used?*
- *Do the drawings identify the bracket or mounting block to be used?*  
The bracket or anchor is part of the listed flexible sprinkler hose fitting approved for use on the project and should be clearly indicated.
- *Do the drawings identify the tamper-resistant features and where labels restricting relocation will be located?*  
Any tamper-resistant features or labels required as part of the product listing should be clearly documented on the design drawings and confirmed during inspection.
- *Do the hydraulic calculations use the identified equivalent based on the length and number of bends used in the design for the specific product selected?*  
The equivalent length used for the flexible sprinkler hose fitting is based on the number of bends and hose diameter listed for the project. Approval for use should be based on an accepted maximum number of bends to be used, which is less than or equal to that permitted by the product listing.

#### **5-4 INSPECTIONS.**

Inspections should be conducted at multiple times during the construction process to ensure that the flexible sprinkler hose fittings are properly installed.

##### **5-4.1 Field Inspections.**

Field inspections should verify:

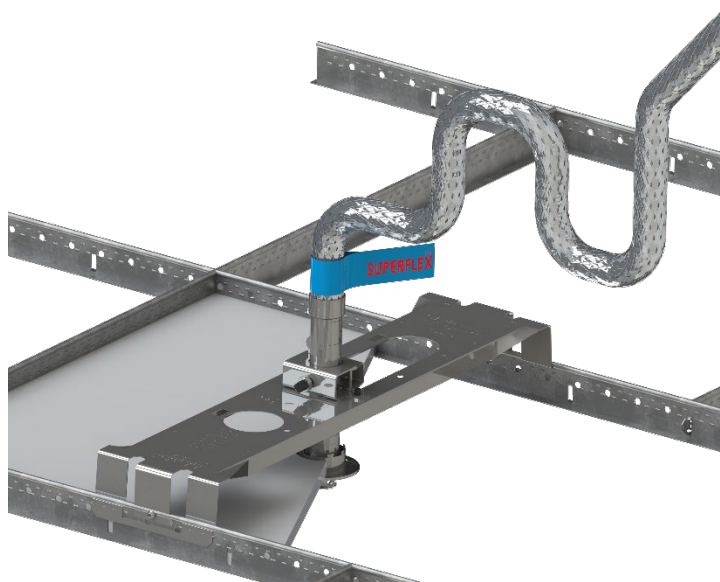
- manufacturer, type, and model
- training in product installation
- length
- connection types
- brackets, ceiling attachments, and set screws
- number of bends
- bend radius
- compliance with installation manual/guide
- flexible sprinkler hose fittings have not been moved or impacted by other trades
- ceiling type and installation meet the requirements of ASTM C635/C635M and ASTM C636/C636M

- installed sprinklers are fitted with protective clips or caps until construction has been completed

#### 5-4.2 Early Inspections.

Early inspections should review whether the products received match those approved for use and included in the design. The inspection should also confirm that the bend radius tools have been received, are on site, and are being properly used. Every 90° change in direction is considered a bend. A hose with a 180° change in flow direction is considered to have two (2) bends.

**Figure 5-1 Flexible Hose with 7 Bends  
(Courtesy of FlexHead®/ASC)**



The approved use also considers that the installers have had training in the proper use and installation of the flexible sprinkler hose fitting products. Training of installers should also be confirmed to prevent undesired installation deficiencies.

**Figure 5-2 Installation of Flexible Hose Fitting  
with Grooved Branch Line Adapter  
(Courtesy of Victaulic)**



#### **5-4.3 Progress Inspections.**

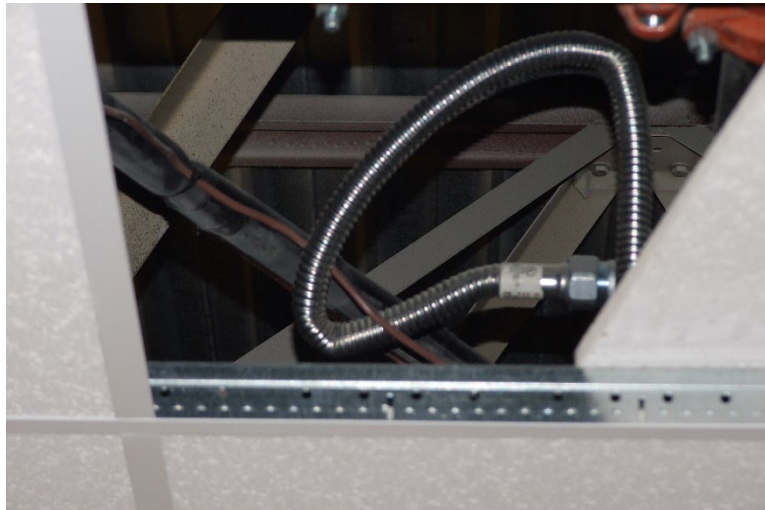
Progress inspections should confirm flexible sprinkler hose fitting locations match the locations identified on the drawings, the number of bends does not exceed the maximum permitted by the listing or design, and that all bends are free of kinks and meet the minimum bend radius requirements.

**Figure 5-3 Kink in Flexible Hose  
(Courtesy of Ralph K. Foster, III, PE, FSFPE)**





**Figure 5-4 Bend Radius Less Than Minimum**  
(Courtesy of Ralph K. Foster, III, PE, FSFPE)



Inspections should confirm that sprinklers have been protected against mechanical damage if installed on flexible sprinkler hose fittings and left hanging prior to the installation of the ceilings, which is common practice. Protective plastic caps or covers should remain on the sprinklers until construction is complete and ready to be accepted.

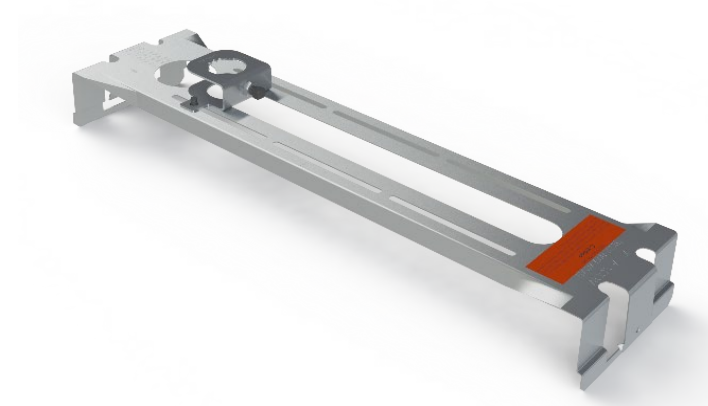
**Figure 5-5 Unprotected Sprinklers Installed on Flexible Sprinkler Hose Assemblies**  
(Courtesy of TERPconsulting)



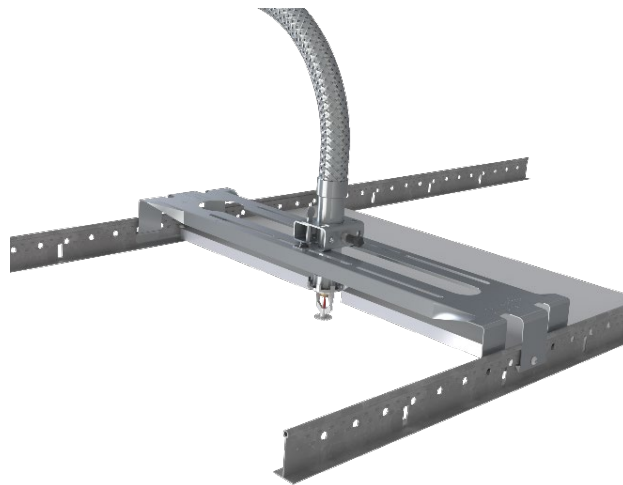


Inspections should confirm that the ceiling, brackets, tamper-resistant features, and labels have been installed correctly.

**Figure 5-6 Bracket with Label  
(Courtesy of FlexHead®/ASC)**



**Figure 5-7 Bracket with Tamper-Resistant Screw Attached to Ceiling Grid  
(Courtesy of FlexHead®/ASC)**



#### **5-4.4 Minimum Inspection Criteria.**

At a minimum, the following questions should be answered “yes” during inspections:

- *Do the flexible sprinkler hose fitting locations observed match those shown on the design drawings?*  
Changes in location should be documented on as-built drawings. Changes in products or flexible sprinkler hose fitting lengths require re-evaluation and approval or should be rejected.
- *Do the flexible sprinkler hose fittings installed match the manufacturer, model number, and length approved and included in the design?*  
The approval for use and design is based on a specific product. Changes require re-evaluation and approval or should be rejected.

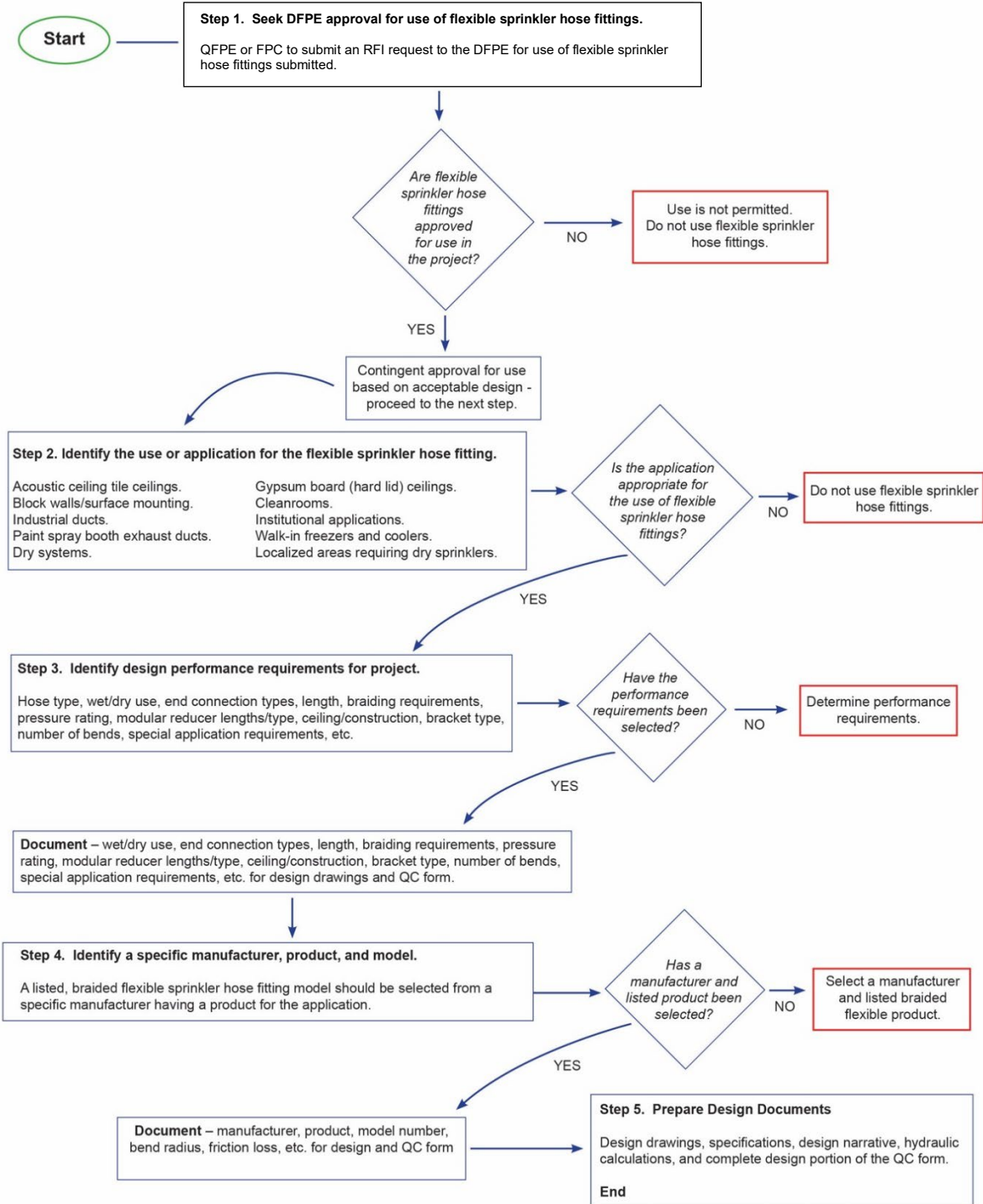
- *Do the number of bends (less than or equal to the number included in the design), and bend radius match the design?*  
Bend radius should be verified using the tool or template provided by the manufacturer. Flexible hoses should be reworked to provide the appropriate bend radius when possible.
- *Are flexible sprinkler hose fittings free of kinks?*  
Flexible hoses with kinks should be removed and replaced according to the manufacturer's instructions.
- *Do the branch line adapter and reducer match those approved and used in the design?*  
Approval for use and design are based on a specific product. Changes require re-evaluation and approval or should be rejected.
- *Does the installed bracket or mounting block match the approved bracket?*  
Approval for use and design are based on a specific product. Changes require re-evaluation and approval or should be rejected.
- *Are the brackets provided with a label to limit relocation of sprinklers?*  
A label is required based on the listing and manufacturer's instructions. The manufacturer should be consulted to obtain labels or replace the product as appropriate based on manufacturer's requirements.
- *Are the tamper-resistant features required by the listing and manufacturer's installation instructions provided?*  
The tamper-resistant features/screws should be installed if missing.
- *Does the ceiling match the design documents and minimum requirements identified by the flexible sprinkler hose fitting manufacturer for the application?*  
Approval for use and design are based on a specific product. Changes require re-evaluation and approval or should be rejected.
- *Are the flexible sprinkler hose fittings free of leaks and damage?*  
Flexible sprinkler hoses with damage or leaks should be removed and replaced according to the manufacturer's instructions.
- *Have the flexible sprinkler hose fittings been installed such that they do not pass through structural joists or other equipment?*  
Flexible sprinkler hose fittings should be reinstalled such that they do not pass through or wrap around structural members or other equipment.
- *Has a copy of the installation instructions been submitted and retained for the project?*  
If not provided, installation instructions should be requested prior to inspection.
- *Has a bend radius tool or template provided by the manufacturer been submitted and retained for the project?*

If not provided, a bend radius tool or template should be requested prior to inspection.

- *Other observations?*  
Include other observations that are not specifically mentioned in the guide but do not adhere to the manufacturer's installation instructions.

*This Page Intentionally Left Blank*

APPENDIX A DESIGN PROCESS FLOW CHART



*This Page Intentionally Left Blank*

**APPENDIX B SAMPLE REQUEST FOR USE**

<b>Request to Use Flexible Sprinkler Hose Fittings</b>	
Project Number	Date
Project Name	
Name	Role
Company	
<b>Product Information</b>	
Application	
Manufacturer	
Model Number	
Listing/Agency	
Branch Line Adapter Connection Type	
Hose Diameter	
Hose Length	
Maximum Number of Bends	
Bend Radius	
Connection to hose	
Reducer Outlet Size	
Reducer Style	
Maximum Ambient Temperature Rating	
Maximum Rated Pressure	
Maximum K-Factor/Orifice	
Bracket type/model	
Equivalent Length	
<b>Approval</b>	
Approved/Rejected	
Approved/Rejected by	
Role	
Date	

*This Page Intentionally Left Blank*



## APPENDIX C EXAMPLE TECHNICAL SPECIFICATIONS

This sample technical specification is intended to provide an example of supplemental information to be added to an existing sprinkler system specification.

### PART 1 – GENERAL

#### 1.1 References

ASTM C635/C635M (2022) *Standard Specification for Manufacture, Performance, and Testing of Metal Suspension Systems for Acoustical Tile and Lay-in Panel Ceilings*

ASTM C636/C636M (2022) *Standard Practice for Installation of Metal Ceiling Suspension Systems for Acoustical Tile and Lay-in Panels*

[NOTE Guide specs already include UL 2443, *Standard for Flexible Sprinkler Hose with Fittings for Fire Protection Service*, and FM 1637, *Approval Standard for Flexible Sprinkler Hose with Threaded End Fittings*]

#### 1.2 System Description

Flexible sprinkler hose fittings shall be permitted to be utilized to provide uniform center-of-tile sprinkler patterns, spaced and located in accordance with NFPA 13.

##### 1.2.1 Hydraulic Calculations

An equivalent length shall be included for [2'], [3'], [4'], [5'], [6'] long flexible sprinkler hose fittings to include [3], [4], [5], [6], [\_\_\_\_] bends. The equivalent length shall be based on the manufacturer's instructions and the corresponding [UL, FM, \_\_\_\_] listing.

Documentation must identify diameter, length, and friction loss for each flexible sprinkler hose fitting.

##### 1.2.2 The design drawings should include the following information for flexible sprinkler hose fittings when used:

- a. Manufacturer
- b. Model number
- c. Hose length
- d. Hose diameter
- e. Hose Type (braided, annular corrugated, etc.) selected
- f. Connection types
- g. Ceiling and minimum requirements
- h. Maximum number of bends
- i. Minimum bend radius
- j. Equivalent length
- k. Pressure rating

- l. Temperature rating
- m. Sprinkler k-factor and orifice size to be attached to the fitting
- n. Bracket to be used
- o. Tamper-resistant features
- p. Friction loss (equivalent length) chart for the selected sprinkler hose fitting along with the specific sprinkler to be used in the design.

### **1.3 Submittals**

It is the responsibility of the QFPE or FPC to submit a request for approval for the use of flexible sprinkler hose fittings for a specific project.

SD-01 Preconstruction Submittals

Approval to Use Flexible Sprinkler Hose Fittings; [G, \_\_\_\_\_]

SD-03

Flexible Sprinkler Hose Fittings; [G, \_\_\_\_\_]

SD-07 Certificates

Verification of Sprinkler System Installer Training; [G, \_\_\_\_\_]

## **PART 2 – PRODUCTS**

2.2.1 Flexible sprinkler hose fittings must comply with UL 2443 (category VENF) and FM 1637 for use in [wet pipe, dry pipe, preaction, and deluge] sprinkler systems.

## **PART 3 – EXECUTION**

### **3.1 Field Quality Control**

Provide [1], [2], [3], [\_\_\_\_] bend radius tool(s) or template(s) to QFPE and DFPE for use during inspections.

The length, model and features of flexible sprinkler hose fittings should be verified to match the approved model and features in the design.

Flexible sprinkler hose fittings should be verified to have [1],[2], [3], [\_\_\_\_] bends.

Flexible sprinkler hose fittings should be verified to have bends meeting the minimum required bend radius and be free of kinks.

Tamper-resistant features and caution labels for flexible sprinkler hose fittings should be verified during inspections.

## APPENDIX D INSTALLATION - COMMERCIAL SPRINKLER SYSTEM MPO-24-BKT-2



### Installation Of FlexHead Commercial Sprinkler Hose Fitting M#: MPO-24-BKT-2

For use with FlexHead hose model numbers 20XX where XX designates hose length in inches, with MPO-24-BKT-2 bracket system.

**Steps:** (Recommend the use of proper PPE for installation)

#### 1. Mounting Bracket Assembly (optional step if require to move open hub center position)

If require to move *open hub* center position on *bracket*, follow step 1 otherwise start at step 2 below. (Fig. 1)

- A. Remove one (1) 3/8" bolt and one (1) 1/4" bolt from bracket. Remove (1) Open Hub and Select one (1) of the four (4) sprinkler port locations on mounting bracket. Thread the 3/8" bolt through side of open hub. (Fig. 1)
- B. Insert tab of open hub into slot on mounting bracket as shown.
- C. Flip bracket over and insert and tighten 1/4" attachment bolt thru pre-punched hole in bracket until tight as shown.

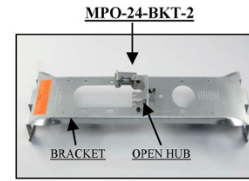


Fig. 1



Fig. 2

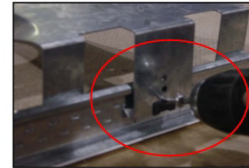


Fig. 3

#### 2. Attach Mounting Bracket to T-bar Suspended Ceiling Grid.

**\*Note:** These products are designed for use with Intermediate or Heavy Duty ceiling grids manufactured to ASTM C 635 (Standard Specification for the Manufacture, Performance, and Testing of Metal Suspension Systems for Acoustical Tile and Lay-in Panel Ceilings) and ASTM C 636 (Standard Practice for Installation of Metal Ceiling Suspension Systems for Acoustical Tile and Lay-in Panels) Designation.

- A. Remove bracket system from box. From above the ceiling, position FlexHead Mounting Bracket ends on to T-bar grid so that the center hole in support bracket aligns directly above the sprinkler hole prepared in ceiling tile. Be sure the center section of the bracket end is on the outside of grid and base section is on the inside. Position the ends of the support bracket on the T-bar grid and push each of the two (2) ends of the bracket down to snap in place as shown. (Fig. 2)

#### 3. Anchor Bracket to T-bar Grid

- A. Anchor bracket to t-bar grid with self tapping screw through bottom hole in bracket end into grid. Be sure to install self tapping screw in lower hole of bracket end as shown. Repeat process on opposite end of bracket. Both ends of bracket should be anchored as shown. (Fig. 3)



Fig. 4

#### 4. Connect FlexHead to Sprinkler Branch-line

- A. Apply Teflon tape and pipe sealant to one inch (1") threaded end of FlexHead Sprinkler Drop per NFPA guidelines. Attach one inch (1") threaded end of FlexHead Sprinkler Drop to branch-line per NFPA, State and local code guidelines.

*Flexible Sprinkler Hose Fittings are only to be installed with bends. Do not install without bends. (See attached Friction Loss Data information for maximum number of bends per hose length.)*

- B. Tighten FlexHead Sprinkler Drop using pipe wrench to the drop head surface as shown. (Fig. 4)



Fig. 5a

**Do not use welded or braided hose section of FlexHead Sprinkler Drop for a wrenching surface.**

#### 5. Secure FlexHead Sprinkler Drop to Mounting Bracket and install Sprinkler Head.

- A. Bend the FlexHead to hold its desired position. **Do not over bend the flexible hose. Each FlexHead sprinkler drop has a 3" (76mm) minimum bend radius per UL and 8" (203mm) minimum bend radius per FM guidelines.** (See attached Friction Loss Data information for maximum number of bends per hose length). Insert reducing coupling end of FlexHead Sprinkler Drop through center hole in previously installed support bracket and hole in ceiling tile. Make sure the hose is bent sufficiently so that the reducing coupling sits perfectly vertical in center hole of support bracket. Do not torque or twist FlexHead during installation process. (Fig. 5a)



Fig. 5b

- B. Close hub on bracket and turn the lock shaft 1/4 turn clockwise as show. Lock hub closed (Fig. 5b)

- C. Adjust FlexHead Sprinkler drop height to accommodate type of sprinkler head to be used. When sprinkler head is in desired location, tighten the 3/8" set screw on center hub of support bracket by turning clockwise hand tight plus 1 turn (torque 100 inch lbs) with wrench as shown in (Fig. 5c).



Fig. 5c

- D. Attach sprinkler head, properly prepared with Teflon tape & sealant to FlexHead Sprinkler according to NFPA & sprinkler head manufacturer's guidelines. Adjust sprinkler head orientation if necessary. (Fig. 5d)

#### 6. Installation of the FlexHead Ceiling Sprinkler System is complete.

\*Test installation of sprinkler system for any leaks per NFPA Guidelines.  
\*Install sprinkler escutcheon from below ceiling per manufacturers guidelines.

Flexhead Industries, Inc.  
56 Lowland Street Holliston, MA 01746 Tel 800-829-6975 / 508-893-

U.S. and International Patent Pending: #6,123,154, #6,119,784, #6,752,218, #7,032,680, #6,488,097  
FGG/BM System Compatible indicates this product has been tested and is monitored on an ongoing basis to assure chemical compatibility with FlowGuard Gold, Blazemaster, and Corzan pipe and fittings. The FlexHead name and logo are trademarks of FlexHead Industries. FGG/BM, FlowGuard Gold, Blazemaster, and Corzan are registered trademarks of Noveon IP Holding Corp.

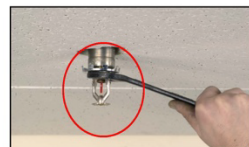


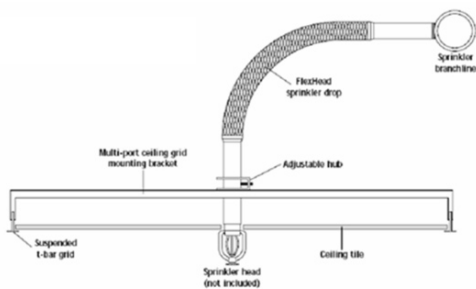
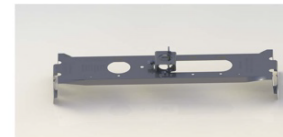
Fig. 5d

<b>*FM* FLEXHEAD® FRICTION LOSS DATA</b>							
Flexhead® Model #	Outlet Size in (cm)	Hose Assembly Length Ft (m)	Maximum Number of 90-Degree Bends (Bending Radius)	Maximum Equivalent Length of Schedule 40, Nominal 1 in Diameter Pipe	Maximum Ambient Temperature Rating F / (C)	Maximum Rated Pressure psi (kPa) / psi (kPa) Standard / H-Series	Maximum K-factor & Orifice of Sprinkler K-factor/ orifice
			8" FM	FM (ft)			
2024, 2024H	1/2 (1.27)	2 (0.6)	1	18.4	300 <sup>o</sup> / (148 <sup>o</sup> )	175 (1205) / 300 (2068)	5.62 / 1/2"
2036, 2036H		3 (0.9)	2	26.6			
2048, 2048H		4 (1.2)	3	30.3			
2060, 2060H		5 (1.5)	4	35.8			
2072, 2072H		6 (1.8)	4	45.6			
2024, 2024H	3/4 (1.90)	2 (0.6)	1	14.7	300 <sup>o</sup> / (148 <sup>o</sup> )	175 (1205) / 300 (2068)	14.0 / 3/4"
2036, 2036H		3 (0.9)	2	21.8			
2048, 2048H		4 (1.2)	3	29.0			
2060, 2060H		5 (1.5)	4	36.1			
2072, 2072H		6 (1.8)	4	43.2			
2024E, 2024HE	1/2 (1.27)	2 (0.6)	1	26.4	300 <sup>o</sup> / (148 <sup>o</sup> )	175 (1205) / 300 (2068)	5.62 / 1/2"
2036E, 2036HE		3 (0.9)	2	30.1			
2048E, 2048HE		4 (1.2)	3	33.8			
2060E, 2060HE		5 (1.5)	4	37.5			
2072E, 2072HE		6 (1.8)	4	41.2			
2024E, 2024HE	3/4 (1.90)	2 (0.6)	1	14.7	300 <sup>o</sup> / (148 <sup>o</sup> )	175 (1205) / 300 (2068)	14.0 / 3/4"
2036E, 2036HE		3 (0.9)	2	21.8			
2048E, 2048HE		4 (1.2)	3	29.0			
2060E, 2060HE		5 (1.5)	4	36.1			
2072E, 2072HE		6 (1.8)	4	43.2			
2024I, 2024IA	1/2 (1.27)	2 (0.6)	1	18.4	300 <sup>o</sup> / (148 <sup>o</sup> )	175 (1205) / 300 (2068)	5.62 / 1/2"
2036I, 2036IA		3 (0.9)	2	26.6			
2048I, 2048IA		4 (1.2)	3	30.3			
2060I, 2060IA		5 (1.5)	4	35.8			
2072I, 2072IA		6 (1.8)	4	45.6			
2024I	3/4 (1.90)	2 (0.6)	1	11.6	300 <sup>o</sup> / (148 <sup>o</sup> )	175 (1205) / 300 (2068)	14.0 / 3/4"
2036I		3 (0.9)	2	16			
2048I		4 (1.2)	3	17.9			
2060I		5 (1.5)	4	24.7			
2072I		6 (1.8)	4	28.9			
				<b>T (ET)</b>			
2024T, 2024ET	1/2 (1.27)	2 (0.6)	1	18.4 (26.4)	300 <sup>o</sup> / (148 <sup>o</sup> )	175 (1205) / N/A	5.62 / 1/2"
2036T, 2036ET		3 (0.9)	2	26.6 (30.1)			
2048T, 2048ET		4 (1.2)	3	30.3 (33.8)			
2060T, 2060ET		5 (1.5)	4	35.8 (37.5)			
2072T, 2072ET		6 (1.8)	4	45.6 (41.2)			
				<b>T (ET)</b>			
2024T, 2024ET	3/4 (1.90)	2 (0.6)	1	14.7 (14.7)	300 <sup>o</sup> / (148 <sup>o</sup> )	175 (1205) / N/A	14.0 / 3/4"
2036T, 2036ET		3 (0.9)	2	21.8 (21.8)			
2048T, 2048ET		4 (1.2)	3	29.0 (29.0)			
2060T, 2060ET		5 (1.5)	4	36.1 (36.1)			
2072T, 2072ET		6 (1.8)	4	43.2 (43.2)			

F R I C T I O N L O S S

<b>* UL* FLEXHEAD® FRICTION LOSS DATA</b>							
Flexhead® Model #	Outlet Size in (cm)	Hose Assembly Length Ft (m)	Maximum Number of 90-Degree Bends (Bending Radius)	Maximum Equivalent Length of Schedule 40, Nominal 1 in Diameter Pipe	Maximum Ambient Temperature Rating F / (C)	Maximum Rated Pressure psi (kPa) / psi (kPa) Standard / H-Series	Maximum K-factor & Orifice of Sprinkler K-factor/ orifice
			3"-UL	UL (ft)			
2024, 2024H	1/2 (1.27)	2 (0.6)	3	11	300° / (148°)	175 (1205) / 300 (2068)	5.62 / 1/2"
2036, 2036H		3 (0.9)	3	16			
2048, 2048H		4 (1.2)	4	24			
2060, 2060H		5 (1.5)	4	29			
2072, 2072H		6 (1.8)	4	35			
2024, 2024H	3/4 (1.90)	2 (0.6)	3	12	300° / (148°)	175 (1205) / 300 (2068)	14.0 / 3/4"
2036, 2036H		3 (0.9)	3	18			
2048, 2048H		4 (1.2)	4	23			
2060, 2060H		5 (1.5)	4	29			
2072, 2072H		6 (1.8)	4	32			
2024T	1/2 (1.27)	2 (0.6)	3	11	300° / (148°)	175 (1205) / N/A	5.62 / 1/2"
2036T		3 (0.9)	3	16			
2048T		4 (1.2)	4	24			
2060T		5 (1.5)	4	29			
2072T		6 (1.8)	4	35			
2024T	3/4 (1.90)	2 (0.6)	3	12	300° / (148°)	175 (1205) / N/A	14.0 / 3/4"
2036T		3 (0.9)	3	18			
2048T		4 (1.2)	4	23			
2060T		5 (1.5)	4	29			
2072T		6 (1.8)	4	32			

- Model Numbers: "H" indicates high pressure unit rated to 300 psig
- Model Number: "ET" indicates for tall elbow drop
- Model number: "I" indicates for Institutional
- Model number: "I" indicates for Institutional for use with the Amerlux ceiling system
- Model Number: "T" indicates for tall
- Model Numbers: "HE" designates high pressure elbow unit rated to 300 psig
- FlexHead products are intended for use in hydraulically designed wet, pre-action, deluge or dry pipe sprinkler per NFPA 13, 13R, and 13D guidelines.
- The hydraulic loss of FlexHead should be included in the hydraulic design calculations the same as a valve or fitting.
- Bracket System MPO-24-BKT-2 has a maximum of 24 inch requirement for anchoring to the building component.
- Intended for use for direct connection to Fire Sprinklers and has limited flexibility.



Rev: C Date: 03/24/16

*This Page Intentionally Left Blank*

## APPENDIX E EXAMPLE QUALITY CONTROL CHECKLIST

### Consideration for Approval to Use Flexible Sprinkler Hose Fittings

1. Has a request form or RFI for the use of flexible sprinkler hose fittings been submitted?  
Yes    No
2. Has the product application or use been clearly identified per section 3-5?  
Yes    No  
*This might include center-of-tile, seismic application, institutional, in-duct, cleanroom, walk-in freezer, localized protection against freezing, or other.*  
Notes: \_\_\_\_\_
3. Has all information necessary to evaluate the product been clearly identified in the request?  
*This should include manufacturer, listing agency, pressure rating, temperature rating, number of bends, hose diameter, limited or high flexibility, branch line adapter type (threaded, grooved, welded), largest sprinkler k-factor or orifice size, number of bends to be included in the design, bend radius, equivalent length, tamper resistance features, labels, wet or dry application.*  
Yes    No  
Notes: \_\_\_\_\_
4. Has information regarding the acoustic ceiling system been submitted?  
*For acoustic ceiling tile ceilings, the ceiling system must meet the requirements of ASTM C635/C635M and C636/C636M, or as specified as part of the product listing. This should be confirmed by the architect and documented in the technical specifications and architectural drawings.*  
Yes    No  
Notes: \_\_\_\_\_
5. For products with multiple listings, has the specific listing intended to be used for the application been clearly identified?  
*The listing standards provide different product performance requirements and limitations such as the number of bends, bend radius, equivalent length to be used in hydraulic calculations.*  
Yes    No  
Notes: \_\_\_\_\_
6. Have the installers been trained by the manufacturer in the use of the flexible sprinkler hose fitting product?  
Yes    No  
Notes: \_\_\_\_\_
7. Is the product approved for use?  
Yes    No  
Notes: \_\_\_\_\_

Design Review

8. Has the approved product been identified in the technical specifications?

Yes No

Notes: \_\_\_\_\_

9. Has the approved product been discussed in the design narrative?

Yes No

Notes: \_\_\_\_\_

10. Do the engineering or working drawings show locations where flexible sprinkler hose fittings will be used?

Yes No

Notes: \_\_\_\_\_

11. Do the drawings include installation details?

Yes No

Notes: \_\_\_\_\_

12. Do the drawings identify the specific model product to be used, the length, connection types, hose diameter, the number of bends, pressure rating, temperature rating, and bend radius to be used?

Yes No

Notes: \_\_\_\_\_

13. Do the drawings identify the bracket or mounting block to be used?

Yes No

Notes: \_\_\_\_\_

14. Do the drawings identify the tamper resistance features and where labels restricting relocation will be located?

Yes No

Notes: \_\_\_\_\_

15. Do the drawings include a friction loss (equivalent length) chart for the selected flexible sprinkler hose fitting along with the specific sprinkler to be used in the design?

Yes No

Notes: \_\_\_\_\_

16. Do the hydraulic calculations use the identified equivalent based on the length and number of bends used in the design for the specific product selected?

Yes No

Notes: \_\_\_\_\_

17. Have annotated product data sheets been submitted with the design?

Yes No

Notes: \_\_\_\_\_



Inspections

18. Do the flexible sprinkler hose fitting locations observed match those shown on the design drawings?

Yes No

Notes: \_\_\_\_\_

19. Do the flexible sprinkler hose fittings installed, match the manufacturer, model number, and length approved and included in the design?

Yes No

Notes: \_\_\_\_\_

20. Do the number of bends (less than or equal to the number included in the design), and bend radius match the design?

Yes No

Notes: \_\_\_\_\_

21. Are the flexible sprinkler hose fittings free of kinks?

Yes No

Notes: \_\_\_\_\_

22. Do the branch line adapter and reducer match those approved and used in the design?

Yes No

Notes: \_\_\_\_\_

23. Does the installed bracket or mounting block match approved bracket?

Yes No

Notes: \_\_\_\_\_

24. Are the brackets provided with a label to limit the relocation of sprinklers?

Yes No

Notes: \_\_\_\_\_

25. Are the required tamper resist features required by the listing and manufacturer's installation instructions provided?

Yes No

Notes: \_\_\_\_\_

26. Does the ceiling match the design documents and minimum requirements identified by the flexible sprinkler hose fitting manufacturer for the application?

Yes     No

Notes: \_\_\_\_\_

27. Are the flexible sprinkler hose fittings free of leaks and damage?

Yes     No

Notes: \_\_\_\_\_

28. Have the flexible sprinkler hose fittings been installed such that they do not pass through structural joists, or other equipment?

Yes     No

Notes: \_\_\_\_\_

29. Has a copy of the installation instructions been submitted and retained for the project?

Yes     No

Notes: \_\_\_\_\_

30. Has a been radius tool or template provided by the manufacturer been submitted and retained for the project?

Yes     No

Notes: \_\_\_\_\_

31. Other observations

\_\_\_\_\_

\_\_\_\_\_

\_\_\_\_\_

\_\_\_\_\_

\_\_\_\_\_

\_\_\_\_\_

\_\_\_\_\_

\_\_\_\_\_

\_\_\_\_\_

\_\_\_\_\_

\_\_\_\_\_

\_\_\_\_\_

\_\_\_\_\_

\_\_\_\_\_

\_\_\_\_\_

\_\_\_\_\_

\_\_\_\_\_

\_\_\_\_\_

\_\_\_\_\_

\_\_\_\_\_

\_\_\_\_\_

## APPENDIX F GLOSSARY

### F-1 ACRONYMS.

AFCEC	Air Force Civil Engineer Center
CFPE	Component Fire Protection Engineer
CPVC	chlorinated polyvinyl chloride
ASTM	American Society for Testing and Materials
CONUS	Continental United States
DFPE	Designated Fire Protection Engineer
FM	Factory Mutual
FPC	Fire Protection Contractor
FRP	fire-resistant plastic
FSFPE	Fellow of the Society of Fire Protection Engineers
IBC	International Building Code
NFPA	National Fire Protection Association
NPT	National Pipe Taper
OCONUS	Outside the Continental United States
PE	Professional Engineer
PPE	personal protective equipment
PVC	polyvinyl chloride
QA	quality assurance
QC	quality control
QFPE	Qualified Fire Protection Engineer
RFI	Request for Information
UFC	Unified Facilities Criteria
UL	Underwriters Laboratories

**F-2 DEFINITION OF TERMS.**

**Bend:** A 90° change in flow direction (turn).

**Bracket:** The anchoring component used to support the flexible hose system for attachment to the ceiling assembly or structure.

**Branch Line Adapter:** The inlet fitting or component used to attach the flexible hose to the sprinkler system branch line.

**Flexible Hose:** The corrugated tube with or without an outer braided sheathing. The hose design can have either a helical or annular design which is determined by the manufacturer based on the intended performance needs for the individual product.

**Flexible Sprinkler Hose Fitting:** A group of four components used to connect a sprinkler to the branch line used to supply the sprinkler. Typically, these fittings include an integral fitting to attach to the branch line, a flexible hose, a fitting for attachment to the sprinkler, and a bracket for attachment to the ceiling assembly or structure.

**High Flexibility Hose Fitting:** A flexible hose fitting intended for applications where frequent movement between the branch line connection and sprinkler is expected.

**Limited Flexible Hose Fitting:** A flexible hose fitting intended for applications where frequent movement between the branch line connection and sprinkler is not expected.

**Minimum Bend Radius:** The minimum radial dimension specified by the manufacturer for the hose to operate.

**Reducer:** The outlet fitting or component used to connect the flexible hose to the sprinkler.

## APPENDIX G REFERENCES

### AMERICAN SOCIETY FOR TESTING AND MATERIALS

<https://www.astm.org/products-services/standards-and-publications.html>

ASTM C635/C635M, *Standard Specification for Manufacture, Performance, and Testing of Metal Suspension Systems for Acoustical Tile and Lay-in Panel Ceilings*

ASTM C636/C636M, *Standard Practice for Installation of Metal Ceiling Suspension Systems for Acoustical Tile and Lay-in Panels*

### FACTORY MUTUAL

<https://www.fmapprovals.com/approval-standards>

FM 1637, *Approval Standard for Flexible Sprinkler Hose with Threaded End Fittings*

### NATIONAL FIRE PROTECTION ASSOCIATION

<https://www.nfpa.org/Codes-and-Standards>

NFPA 3, *Standard for Commissioning of Fire Protection and Life Safety Systems*

NFPA 13, *Standard for the Installation of Sprinkler Systems*

NFPA 13D, *Standard for the Installation of Sprinkler Systems in One- and Two-Family Dwellings and Manufactured Homes*

NFPA 13R, *Standard for the Installation of Sprinkler Systems in Low-Rise Residential Occupancies*

NFPA 25, *Standard for the Inspection, Testing, and Maintenance of Water-Based Fire Protection Systems*

### UNDERWRITERS LABORATORY

<https://www.shopulstandards.com/>

UL 2443, *Flexible Sprinkler Hose with Fittings for Fire Protection Service*

### UNIFIED FACILITIES CRITERIA

<https://www.wbdg.org/ffc/dod/unified-facilities-criteria-ufc>

UFC 1-200-01, *DoD Building Code*

UFC 3-600-01, *Fire Protection Engineering for Facilities*

UFC 3-601-02, *Fire Protection Systems Inspection, Testing, and Maintenance*

### OTHER

IBC, *International Building Code*

<https://www.iccsafe.org/products-and-services/i-codes/2018-i-codes/ibc/>