

**KEY NOTES**

1. P3200, ELECTRONIC LAVATORY, MAY BE USED INSTEAD OF P3100, LAVATORY. FOR THE P3200 PROVIDE EITHER BATTERY POWER OR HARD WIRED CONNECTION.
2. INCREASE THIS DIMENSION AS NEEDED TO COMPLY WITH ADA IF THE DOOR HAS A CLOSER OR IF 610 [2'-0"] CLEARANCE IS NOT AVAILABLE AT THE STRIKE SIDE OF THE DOOR.
3. COORDINATE LOCATION OF M1620, PATIENT CHART HOLDER, AND ROOM SIGNAGE.
4. MOUNT A5145, HOOK, AT 1372 [4'-6"] AFF.
5. MOUNT A5145, HOOK, AT 1219 [4'-0"] AFF. PROVIDE 2-A5145'S FOR NAVY PROJECTS ONLY. MOUNT 1-A5145 AT 1219 [4'-0"] AFF AND 1-A5145 AT 1524 [5'-0"] AFF.
6. LENGTH OF E1500, WALL MOUNTED RAIL, TO BE DETERMINED BY MANUFACTURER/INSTALLER.

**EXAM ROOM, ENT (EXEN1)**

AUDIOLOGY/SPEECH PATHOLOGY/ENT

FLOOR/EQUIPMENT PLAN 11.15 NSM (120 NSF)

DATE: 01/28/2002

0 1000 2000



1:50 SCALE (MILLIMETERS)

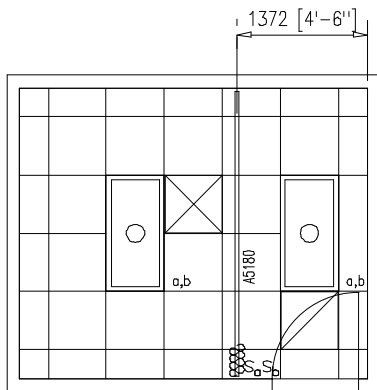

EXAM ROOM, ENT (EXEN1)

AUDIOLOGY/SPEECH PATHOLOGY/ENT

CEILING PLAN

11.15 NSM (120 NSF)

DATE: 01/28/2002

0 1000 2000



1:50 SCALE (MILLIMETERS)

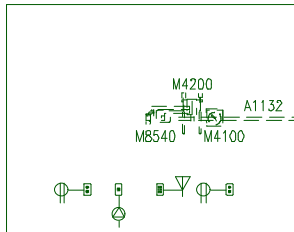

WEST

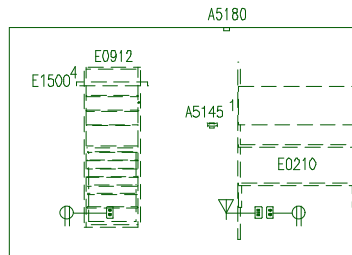

NORTH

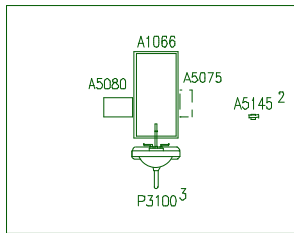

EAST

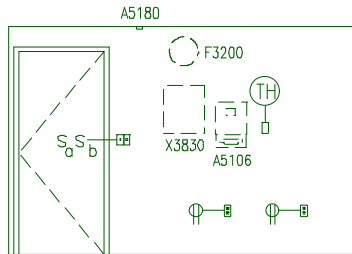

SOUTH

KEY NOTES

1. MOUNT A5145, HOOK, AT 1372 [4'-6"] AFF.
2. MOUNT A5145, HOOK, AT 1219 [4'-0"] AFF. PROVIDE 2-A5145'S FOR NAVY PROJECTS ONLY.  
MOUNT 1-A5145 AT 1219 [4'-0"] AFF AND 1-A5145 AT 1524 [5'-0"] AFF.
3. P3200, ELECTRONIC LAVATORY, MAY BE USED INSTEAD OF P3100, LAVATORY. FOR THE P3200 PROVIDE EITHER BATTERY POWER OR HARD WIRED CONNECTION.
4. LENGTH OF E1500, WALL MOUNTED RAIL, TO BE DETERMINED BY MANUFACTURER/INSTALLER.

General Notes:

1. For typical equipment mounting heights see "TYPICAL EQUIPMENT MOUNTING HEIGHTS" drawing.
2. MIL-STD-1691 data can only be accessed from the Equipment Plan.

EXAM ROOM, ENT (EXEN1)

AUDIOLOGY/SPEECH PATHOLOGY/ENT

ELEVATIONS

11.15 NSM (120 NSF)

0 1000 2000



DATE: 01/28/2002

1:50 SCALE (MILLIMETERS)

Project Rooms (User Contents Only)

As of 06/08/2005

Page 1

Room Code: EXEN1 Room Qty: 1 Room Area: 120.01 Room Description: EXAM ROOM, ENT

JSN	NOMENCLATURE	Qty	UNIT	LOG	Utl	Utl	Utl	Utl	Utl	Utl
			ISSUE	CAT	1	2	3	4	5	6
Equipment per Room:										
A1066	Mirror, Float Glass, With SS Frame, 36X18	1	EA	A	.	.	.	.	.	.
A1132	Rail, Accessory Mounting, Length As Required	1	LF	C	.	.	.	.	.	.
A5075	Dispenser, Soap, Disposable	1	EA	C	.	.	.	.	.	.
A5080	Dispenser, Paper Towel, SS, Surface Mounted	1	EA	A	.	.	.	.	.	.
A5106	Waste Disposal Unit, Sharps w/Glove Dispenser	1	EA	C	.	.	.	.	.	.
A5145	Hook, Garment, Double, SS, Surface Mounted	2	EA	A	.	.	.	.	.	.
A5180	Track, Cubicle, Surface Mounted, With Curtain	1	FT	A	.	.	.	.	.	.
E0210	Worksurface, w/Overhead Cab, Wall Mtd, 48" W	1	EA	C	.	A	.	.	.	.
E0912	Locker, Supply, Med Surg, Wall Mtd	1	EA	C	.	.	.	.	.	.
E1500	Rail, MOD, W/MNTD, HX144XD	1	EA	C	.	.	.	.	.	.
F0205	Chair, Side With Arms	1	EA	C	.	.	.	.	.	.
F0280	Chair, Swivel, Low Back	1	EA	C	.	.	.	.	.	.
F0340	Stool, Self Adjusting	1	EA	C	.	.	.	.	.	.
F2000	Basket, Wastepaper, Round, Metal, 18 H x 16 Dia.	2	EA	C	.	.	.	.	.	.
F3200	Clock, Battery, 12" Diameter	1	EA	C	.	.	.	.	.	.
M1620	Holder, Chart, Patient, Wall or Door Mounted	1	EA	A	.	.	.	.	.	.
M1800	Computer, Microprocessing, w/CRT Monitor	1	EA	C	.	A	.	.	.	.
M3072	Frame, Infectious Waste Bag w/Lid	1	EA	C	.	.	.	.	.	.
M4100	Sphygmomanometer, Aneroid, Wall Mounted	1	EA	C	.	.	.	.	.	.
M4200	Otoscope/Ophthalmoscope, Wall Mounted	1	EA	C	.	A	.	.	.	.
M4840	ENT Unit, w/Air, Electric Power, Suction, Pressu	1	EA	C	.	A	H	.	.	.
M4915	Chair, Exam/Treatment, ENT, w/Adjustable Light	1	EA	C	.	A	.	.	.	.
M8540	Microscope, Operating, Wall Mounted	1	EA	C	.	A	.	.	.	.
P3100	Lavatory, Vitreous China, Slab Type	1	EA	A	D	.	.	.	.	.
X3830	Illuminator, Film, Single, Wall Mounted, 20x17x5	1	EA	C	.	A	.	.	.	.

\*\*\*GRAND TOTAL\*\*\*

27