

PUBLIC WORKS TECHNICAL BULLETIN 420-49-31
6 SEPTEMBER 1999

**LESSONS LEARNED AT THE FORT SILL
CENTRAL VEHICLE WASH FACILITIES**

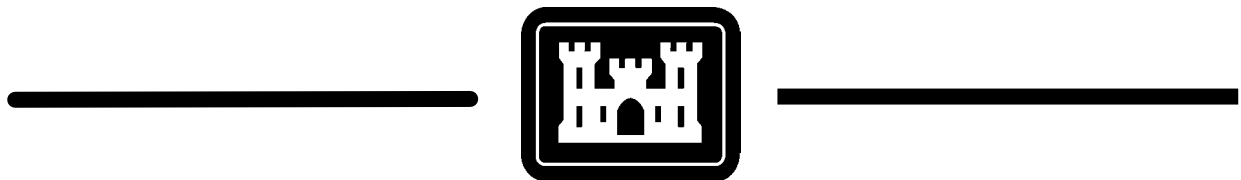

Technical Bulletins are published by the U.S. Army Corps of Engineers, Washington, DC. They are intended to provide information on specific topics in areas of Facilities Engineering and Public Works. They are not intended to establish new DA policy.

DEPARTMENT OF THE ARMY
US Army Corps of Engineers
441 G Street, NW
Washington, DC 20314-1000

Public Works Technical Bulletin
No. 420-49-31

6 September 1999

FACILITIES ENGINEERING
Utilities

LESSON LEARNED FOR THE FORT SILL
CENTRAL VEHICAL WASH FACILITIES

1. Purpose. This Public Works Technical Bulletin (PWTB) provides design recommendations for Central Vehicle Wash Facilities (CVWFs) based on the evaluation of innovations implemented at Fort Sill, Oklahoma.
2. Applicability. This PWTB applies to all Corps of Engineers Districts and Department of the Army installations responsible for construction, and operation and maintenance (O&M) of CVWFs.
3. References.
 - a. Public Law 100-4, Clean Water Quality Act (CWA) of 1987.
 - b. AR 420-49, Utility Services, 28 May 1997.
 - c. Technical Manual 5-814-9, Central Vehicle Wash Facilities, February 1992.
4. Discussion.
 - a. The CVWF is designed to provide expedient, cost-effective cleaning for tactical vehicles. The concept incorporates water conservation including recycle techniques and pollution control.
 - b. Two significant maintenance problems have been occurring at CVWFs: frequent plugging of the intermittent sand filters and inefficient removal of sediment from the sedimentation basin. The CVWFs at Fort Sill were evaluated for lessons learned.
 - c. Appendix A contains the details of the Fort Sill CVWF evaluation. The Appendix includes conclusions arrived at as a result of the onsite evaluation and interviews with key personnel responsible for operation and maintenance (O&M) requirements. Recommendations are also made for future design improvements.

PWTB 420-49-31
6 September 1999

5. Points of Contact. Questions and/or comments regarding this subject that cannot be resolved at the installation level should be directed to: US Army Corps of Engineers, CEMP-RI, 441 G Street, NW, Washington, DC, 20314-1000; or: US Army Engineer Research and Development Center, Construction Engineering Research Laboratory, at 1 (800) USA-CERL, for Mr. Gary Gerdes (e-mail g-gerdes@cecer.army.mil).

FOR THE DIRECTOR:

/S/

FRANK J. SCHMID, P.E.
Chief, Installation Support Policy Branch

APPENDIX A

LESSON LEARNED FOR THE FORT SILL CENTRAL VEHICLE WASH FACILITIES

1. CVWF History.

a. The concept for Central Vehicle Wash Facilities (CVWFs) was developed by the U.S. Army Construction Engineering Research Laboratory (CERL) in the late 1970s. The CVWF allows the exterior of tactical vehicles to be cleaned in an efficient and environmentally safe manner. A CVWF consists of various structures for washing tactical vehicles and a wastewater treatment system for recycling the wash water. More than 20 of these facilities have been constructed at U.S. Army Forces Command (FORSCOM) and U.S. Army Training and Doctrine Command (TRADOC) installations.

b. When the CVWF concept was developed, it was assumed that minimal resources would be available to operate and maintain the facilities. The treatment system had to be simple to operate, inexpensive to maintain, cost effective, and had to provide discharge quality water for recycling. The treatment had to remove large quantities of settleable and suspended solids as well as smaller quantities of oil and grease. Researchers ruled out processes that require constant monitoring, skilled operators, chemical feeds, large amounts of energy, and would otherwise be an unreasonable drain on Directorate of Public Works (DPW) budgets.

b. The recommended recycle treatment is primary sedimentation with floating oil removal, followed by intermittent sand filtration. Guidance for planning and constructing CVWFs has been published in TM 5-814-9 "Central Vehicle Wash Facilities." A schematic of a typical CVWF layout is shown in Figure 1 (HQDA 1992).

2. Significant Operations and Maintenance (O&M) Problems.

a. A few maintenance problems are occurring at CVWFs that were not anticipated during the development of the original concept. The CVWF had no predecessor and no operational history to draw upon, so it is reasonable that the concept should require some adjustments. Two specifically troublesome problems are (1) frequent plugging of the intermittent sand filters and (2) inefficient removal of sediment from the sedimentation basin.

b. Sand filters at CVWFs located in warmer climates and in areas where soils have high clay content plug more frequently than was anticipated. Plugging was expected to occur, of course, as the suspended soil particles in the wash water collected on the surface of the filter. Researchers predicted that the surface of the sand filters would require raking every year or so, and would require sand replacement about every 10 years. In practice, this schedule has not been the case at some installations, where surface sand requires replacement annually. A contributing factor to the premature plugging was found to be biological growth on the surface of the sand (Gerdes 1991). Figure 2 shows the recommended specification for intermittent sand filter media. Figure 3 shows the dried surface of a sand filter plugged by biological growth.

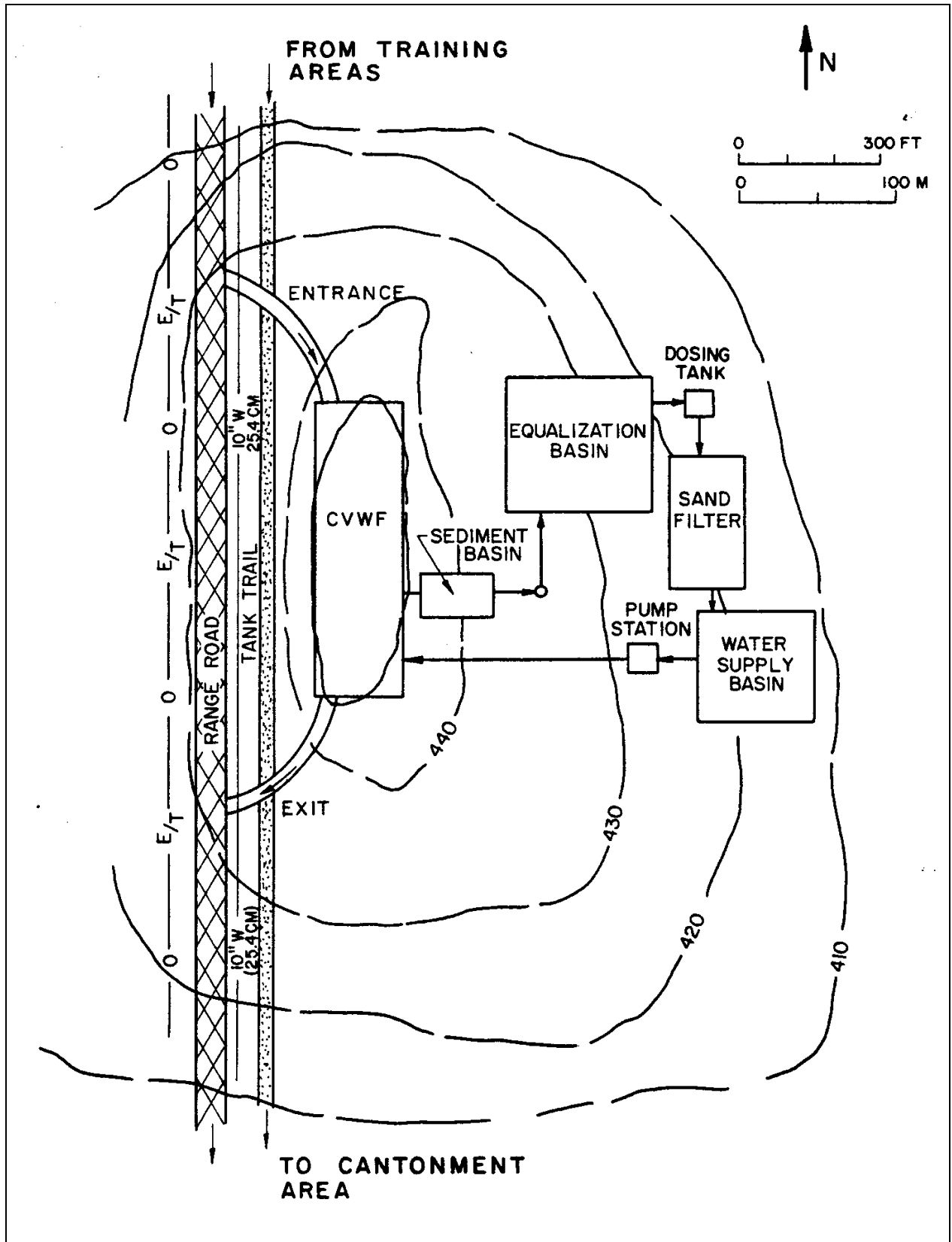

Figure 1. Example site layout schematic (Ref 1, page A-7).

c. Sedimentation basins at a typical FORSCOM installation CVWF may capture over 1,000 cu yd of sediment per year. The intended cleanout procedure was to periodically shut down and drain the two sedimentation basins; allow the sediment to dry in the basin; and then remove it with earthmoving equipment. The acceptable frequency for cleanout is established during the design process and the basins sized accordingly. Actual operation has shown that the rate of sediment accumulation between cleanouts was predicted fairly accurately. However, the resources required to do that cleanout were underestimated. Figures 4, 5, and 6 show sketches (from TM 5-814-9) of the recommended configuration of sedimentation basins.

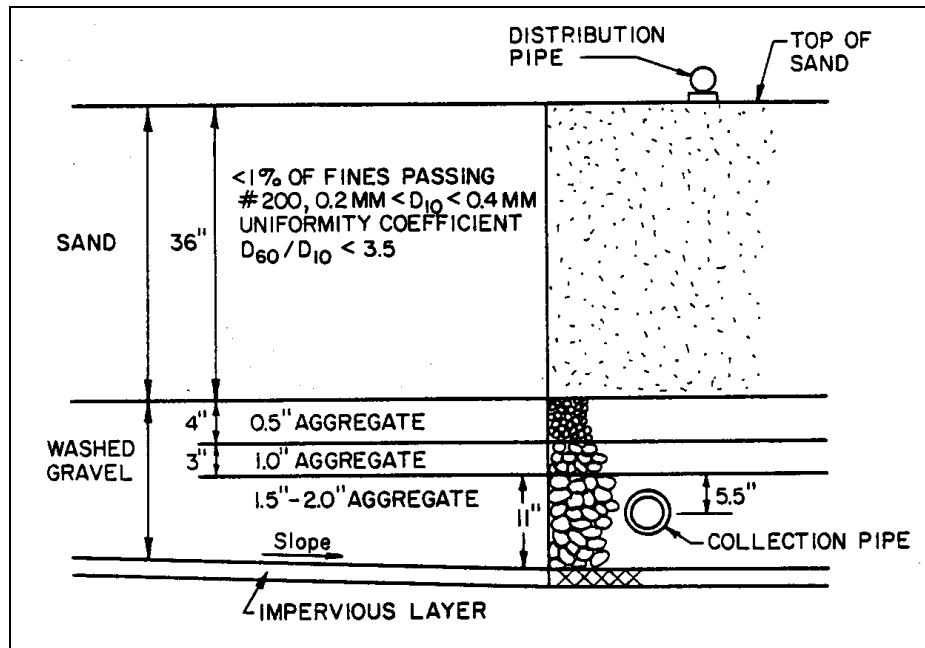

Figure 2. Specifications for intermittent sand filter media.



Figure 3. Dried matted material on the surface of a sand filter.

d. The sediment to be removed from the basin was very difficult to dewater and dry in place, which meant that the basin being cleaned had to be kept out of service for weeks or months before the drying was complete. An alternative to remove the sediment while it was still liquid was normally chosen because the CVWF cannot be kept out of operation for such long periods. However, moving the wet sediment using earthmoving equipment was very time consuming, created much spillage around the basins and on the route to the disposal site, and presented the problem of passing the paint filter test to allow land disposal as a solid waste. It was clear that drying the sediment in the basin did not meet the original concept goal of low maintenance, nor did removing it wet. Sediment removal is a problem at almost every CVWF.

3. **Recommended Design Improvements.** CERL has researched both problems described above. The results of that research were incorporated into two CVWFs constructed at Fort Sill, OK, in 1996 and 1997.

a. *Intermittent Sand Filters.*

(1) During the study, evidence of biological growth was detected on the surface of intermittent sand filters that were becoming plugged. It was theorized that, when soil particle accumulation slowed flow through the filter and created ponding, it created an aquatic environment conducive to biological growth. Microorganisms formed a film around the soil particles on the filter surface and quickly reduced flow through the filter.

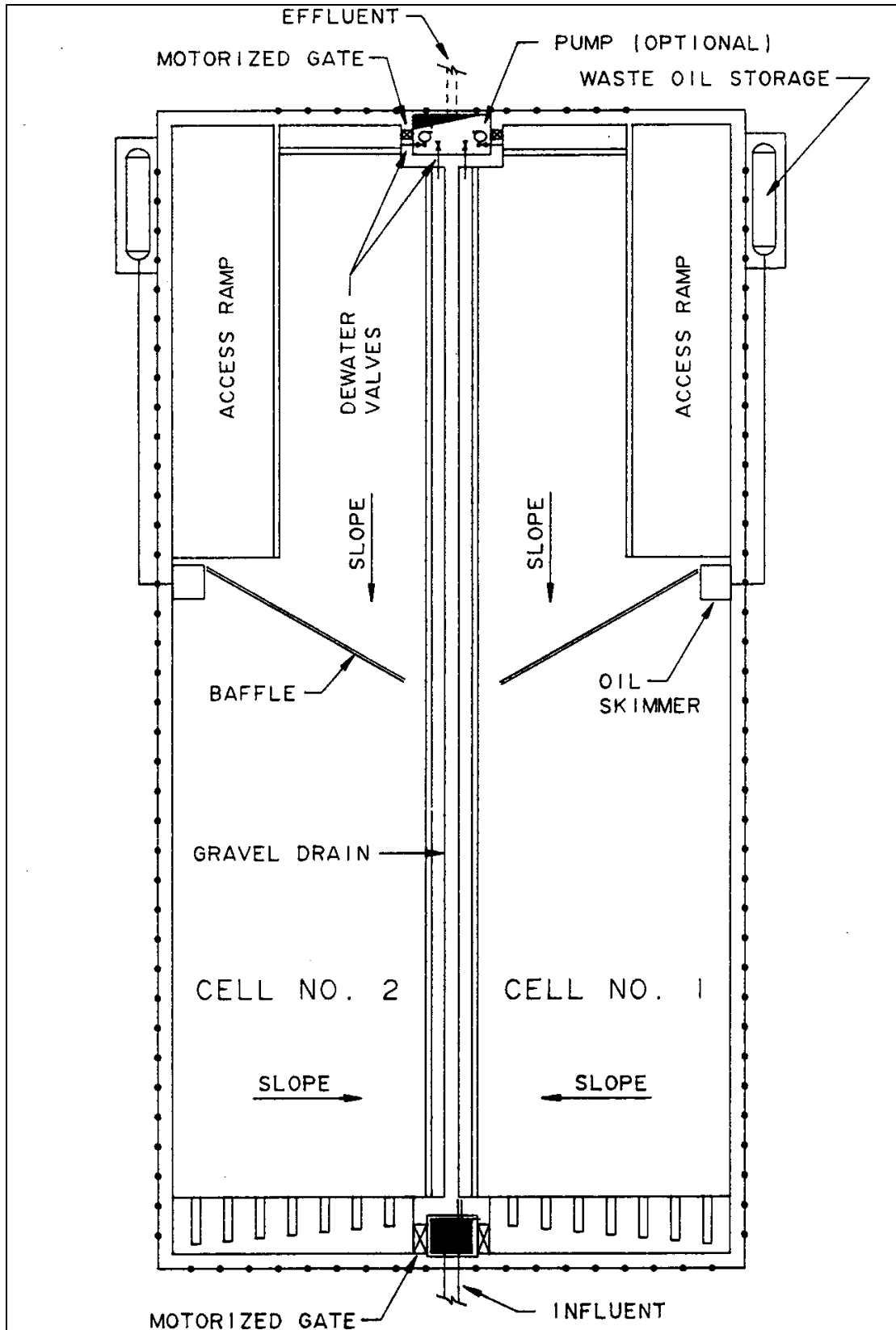

Figure 4. Sedimentation basin plan view.

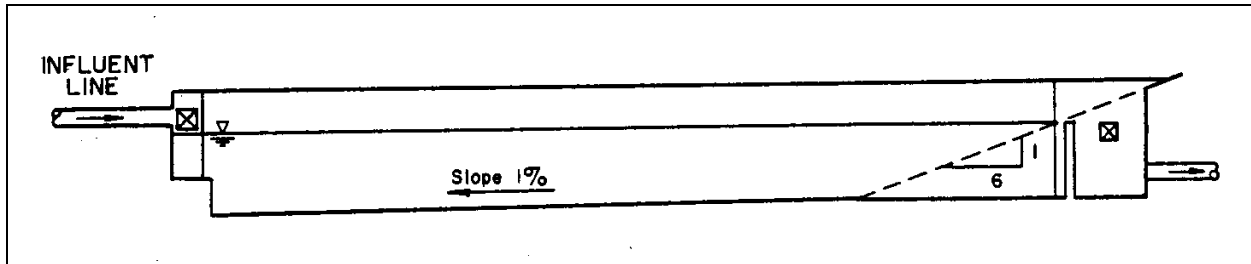

Figure 5. Section of typical sedimentation basin.

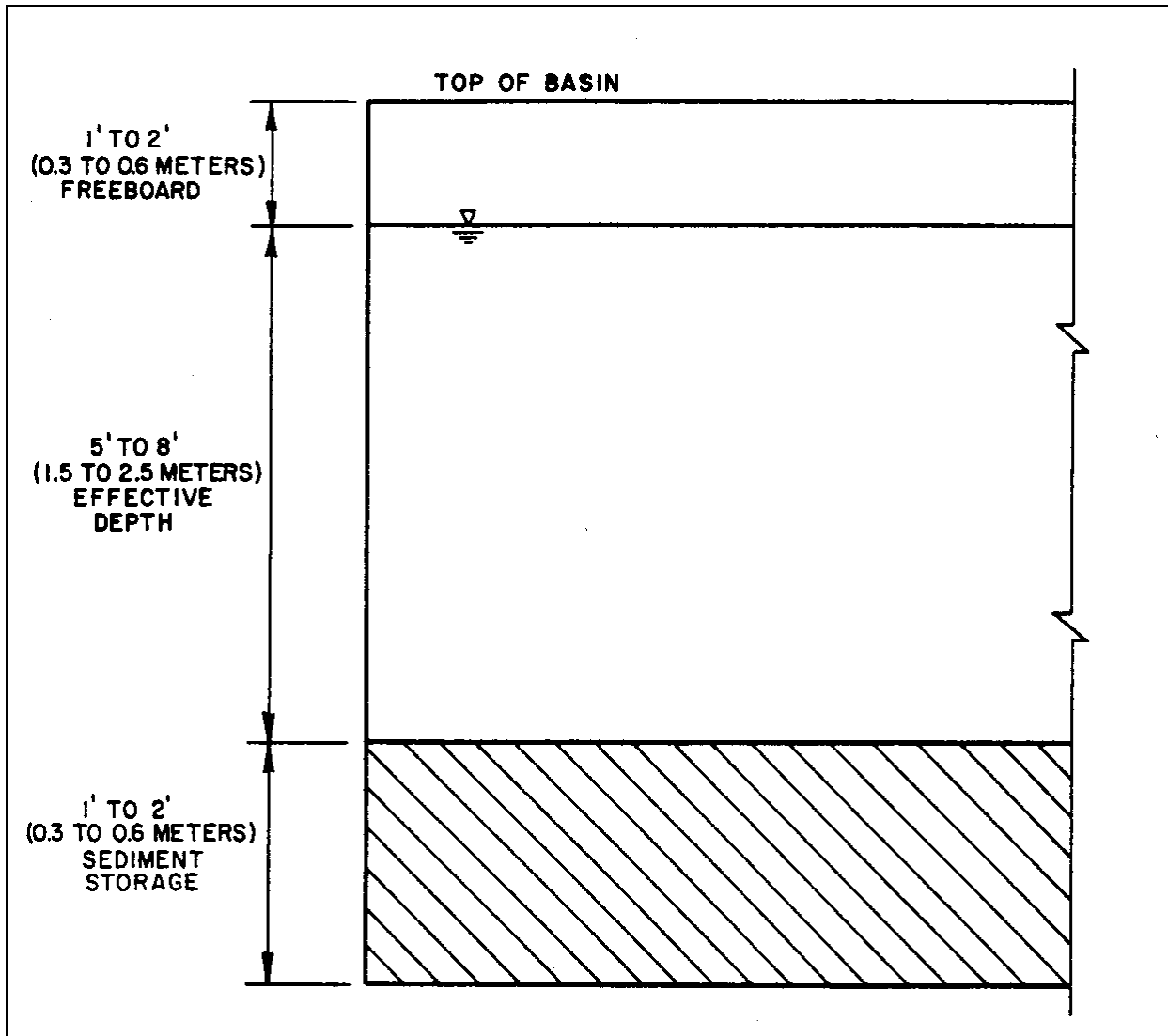

Figure 6. Typical design water and sediment depths.

(2) Suggested alternatives to lessen the plugging were to: (1) replace the intermittent sand filters with rapid sand filters, (2) replace the intermittent sand filters with constructed wetland treatment, and (3) incorporate disinfection. CERL had ruled out the rapid sand filter option during the original CVWF concept development. While rapid sand filters could be returned to service quickly after backwashing, the backwashing operation required a means of treating the backwash water. It also required a trained operator to monitor the operation. This option meant much higher operating costs, as well as higher construction costs for the filters.

(3) The constructed wetland treatment is recommended as the alternative to intermittent sand filters. The constructed wetland can produce a very good effluent, and requires very little resources for O&M. Drawbacks to wetland treatment are a general reluctance to use this technology and a fear that wetlands might create a mosquito problem. Personnel at most Army installations are unfamiliar with constructed wetlands technology, and mosquitoes would be aesthetically unpleasant as well as potentially unhealthy.

(4) Disinfection was selected as the most workable alternative during the design of the Fort Sill CVWFs. Brief experiments conducted by CERL at one installation showed that swimming pool chemicals could be used successfully in a shock-loading application to control growth on the filter surface. The personnel at Fort Sill chose to use chlorine gas for disinfection, because they already used that type of disinfection at their sewage treatment plant. Chlorine gas is a much more aggressive disinfectant; however, it generally requires more stringent safety measures than other types of chlorine disinfection. Figure 7 shows diagrams of the chlorination system at both Fort Sill CVWFs. These diagrams were taken from the advanced final design drawings for the East CVWF.

b. *Sediment Removal.*

(1) A CERL research study found that the sedimentation basin tends to act as a soil particle classifier. Heavier sand and pebbles always collect at the influent end of the basin. Clay particles tend to cover more than half of the bottom of the basin toward the effluent end. The sediment in the effluent end always dewater and dries very slowly. It is a difficult, if not impossible, challenge to find a way to dewater and dry the sediment that will improve the operation of the wash facility at the same time that it minimizes O&M costs.

(2) It is critical to keep downtime at the CVWF at a minimum. Therefore, the dewater fix had to involve either removing the sediment wet and then drying it in another location, or finding a method to quickly dry it in place. The most practical methods to dry the sediment in place seemed to be limited to mixing in absorbents or dry soil to reduce the average moisture content. This method seemed very labor intensive and did little to improve upon the method of removing the sediment while wet. The most reasonable method to dewater the sediment seemed to be to remove it wet from the basin to a drying area a short distance away. This option was used for the Fort Sill CVWFs.

4. Observations at Fort Sill

a. *Disinfection System.*

(1) Disinfection systems were installed at both Fort Sill CVWFs according to the drawings in Figure 7. In this system, chlorine is added to the wash water as it is pumped to the sand filters. The concentration of chlorine in the recycle water is not monitored anywhere in the system. However, the flow going to the filters and the rate at which chlorine is injected is known, so an average concentration of chlorine applied can be calculated. Chlorine is injected at a rate of 5 lb/hr into a flow of 1,400 gpm; thus, the average chlorine concentration should be about 7 mg/L.

(2) This dosage rate did not seem effective. Evidence showed that biological growth still occurred on the filter surfaces. It is suspected that the free chlorine is tied up by the organic material suspended in the wash water. The sand filters at Fort Sill were designed to be operated as slow rather than as intermittent sand filters (per TM guidance). The constant 3-ft depth of water over the filter surface means that there is significant contact time for the free chlorine to be tied up by contaminants in the water. It is likely, therefore, that very little free chlorine actually makes it to the surface of the filters.

(3) For this reason, the disinfection and filtration system at Fort Sill cannot be considered successful in its current mode of operation. However, minor changes to the operation may improve its performance. One option to correct the problem is to raise the concentration of chlorine to ensure that there is a residual to contact the filter surface. However, this probably would unnecessarily increase operating costs. It is suggested that changing the mode of chlorine application might improve disinfection of the filter surfaces. Rather than applying a continuous low level of chlorine, applying periodic high levels of chlorine may be more effective. This operation would be similar in principle to shock loading or breakpoint chlorination used to control biological growth in water distribution systems. Initially, concentrations of 20 mg/L or higher might be applied weekly. The procedure would then be monitored for success in controlling bio-growth, and the chlorine concentration and frequency of application would be modified as appropriate. This mode of disinfectant chemical addition is recommended for all future CVWFs.

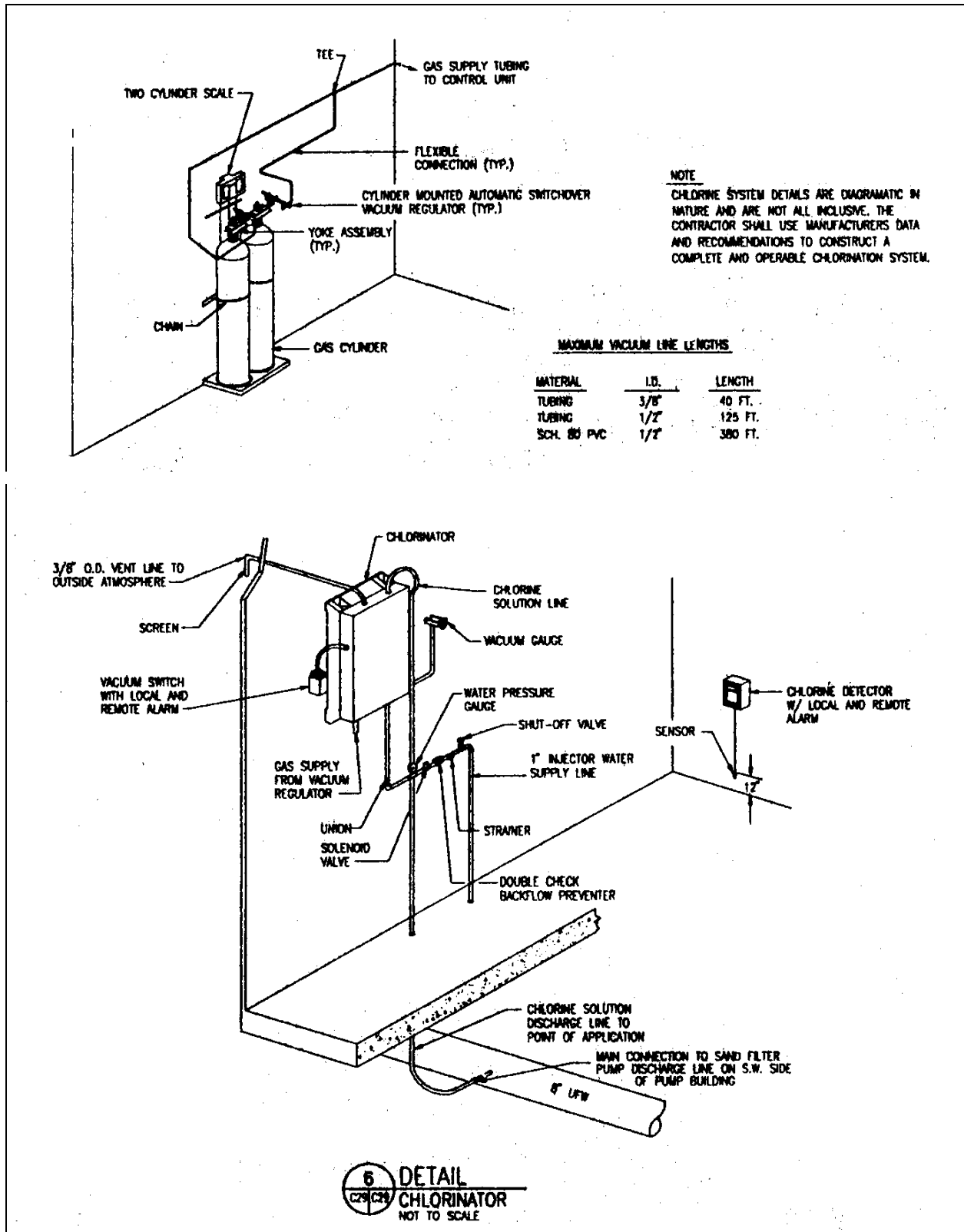

Figure 7. Fort Sill chlorination system.

(4) The overall cost of operation should decrease with this intermittent method of chlorine application. Assume the chlorine concentration applied to the filters is tripled, but is applied to only 10 percent of the flow rather than 100 percent. Thus, chlorine cost would decrease by 70 percent.

(5) It is likely that chlorine disinfection of the filter surface would be more successful if the sand filters were operated in the intermittent mode rather than the slow sand filter mode. The operating scheme for intermittent sand filters is to dose them with 6 to 12 in. of wash water every 8 hr, and allow the wash water to completely infiltrate the filters between doses. Changing to an intermittent mode would eliminate the apparent low chlorine residual caused by the constant layer of water above the filters while in the slow sand filter mode. Another disadvantage of slow sand filters is that the constant 3-ft head above the filter surface may tend to drive suspended soil particles deeply into the surface of the sand, thus making skimming or raking the surface of the filters less effective in prolonging the period of usage. CERL recommends against the use of slow sand filters at future CVWF facilities.

b. *Sediment Dewatering and Drying.*

(1) Interviews with Fort Sill CVWF personnel indicated that the sediment drying pad was partially successful in decreasing facility downtime and cleanout costs. Having the concrete drying area adjacent to the sedimentation basins can potentially decrease the downtime. Sediment can be removed before it is dried and the sedimentation basin returned to service. However, transferring the liquid sediment to the drying pad with earthmoving equipment was still very time consuming. In fact, because so much spillage occurred around the basin, the operators at Fort Sill now leave the sediment in the basins for 2 to 3 wk to partially dry before transferring it to the drying pad. Even after partial drying, it takes 4 to 6 days to transfer sediment from one basin to the drying pad. While downtime of the sedimentation basin has been reduced, it certainly has not been eliminated.

(2) One obvious disadvantage of this design is that the sediment must be moved twice — once to the drying pad and a second time to the ultimate disposal site — with a delay of several weeks between the two transfers. If the weather is dry, and the sediment is “worked” and mixed on the drying pad, the drying time can be shortened to 2 wk. On the plus side, the long distance transfer to the disposal site is much more efficient because dump trucks can be fully loaded with dry dirt. With liquid sediment, the trucks can be only partially loaded and must travel much more slowly. At Fort Sill, the dried sediment is carried to the landfill to be used as cover material. An unexpected advantage of the drying bed is that sediment can remain stored there until the results of hazardous waste characteristic testing and other analyses can be completed.

(3) Information is not available to compare the labor and equipment requirements of sediment drying and transfer with and without the drying pad at Fort Sill. However, based on observations at similar CVWFs at Forts Carson and Hood, the resource requirements are about the same.

c. *Recommended Slope Modification.* Another design feature that should be mentioned is the modified slope on the ramps into the sedimentation basins. Previously, a 1:6 slope was used on the ramps and equipment often had trouble climbing the ramp when muddy. At Fort Sill, the slope of the ramp was decreased to 1:11. It is much easier for equipment to be driven in and out of the basin. Had the slope been steeper, transferring the sediment from the basin to the drying bed would take much longer. This design modification is recommended for all future CVWFs.

d. ***Recommended Improvement to Basin Design.*** The efficiency “bottleneck” at the Fort Sill facilities is the removal of sediment from the basin to the drying pad. The transfer could be accomplished much more easily if the sediment could be pushed directly from the sedimentation basin to the drying pad. This capability was suggested at a recent design meeting for a CVWF to be constructed at Yakima Training Center, Washington. The idea was accepted, and the facility is being designed so a portion of the sedimentation basin wall can be removed, allowing the sediment to be pushed directly from the basin onto the drying pad. No loading and unloading will be required until it is transferred for disposal. Down time for the sedimentation basin should be 1 day for draining/dewatering and 1 day for transfer of sediment. Seen as a significant improvement, this feature is recommended for all new CVWFs. It is also recommended that the site layout of new CVWFs take into account the elevations required for same-grade transfer of sediment from the floor of the sedimentation basin onto an adjacent drying pad.

5. Conclusions

- a. The disinfection and filtration system at Fort Sill cannot be considered successful in its current mode of operation.
- b. It is likely that chlorine disinfection of the filter surface would be more successful if the sand filters were operated in the intermittent rather than the slow sand filter mode.
- c. The sediment drying pad at Fort Sill was partially successful in decreasing facility downtime and cleanout costs. The most resource-intensive operation during the cleanout of the sedimentation basins is the transfer of sediment from the basin to the drying pad.
- d. The 11:1 slope on the entrance ramps to the sedimentation basins helped make the basin cleanout more efficient.

6. Recommendations.

- a. Apply high concentrations of disinfectant chemical periodically to control biological growth on the surface of sand filters, instead of continuous application of lower concentrations.
- b. Construct intermittent sand filters, as opposed to slow sand filters, at future CVWF facilities.
- c. Use a 11:1 slope for the entrance ramps to sedimentation basins at all future CVWFs.
- d. Design a feature to allow sediment to be pushed from the sedimentation basin onto a drying pad for all new CVWFs. Take into account the elevations required to construct the drying pad at the same elevation as the bottom of the basin.

7. References

- a. Central Vehicle Wash Facilities, TM 5-814-9, Headquarters, Department of the Army (HQDA), February 1992.
- b. Central Vehicle Wash Facility (East), Fort Sill, Lawton, Oklahoma, Advanced Final Submittal, June 5, 1995, Armour, Cape and Pond, Architects and Engineers.
- c. Gerdes, Gary L., et al., Evaluation of Alternatives for Secondary Treatment at Central Vehicle Wash Facilities, USACERL Technical Report N-91/29, August 1991.
- d. Gerdes, Gary L., and Joseph E. Matherly, "Report of Findings — Aberdeen Proving Ground CVWF Study November 1989 through August 1990," Unpublished Letter Report for Aberdeen Proving Ground DPW, November 1990.
- e. Pierson, John A, Robert Wallace, and Dr. Michael F. Saunders, "Intermittent Sand Filtration for Military Wash Rack Operations," Georgia Tech Research Institute, December 1997.

PWTB 420-49-31
6 September 1999

This publication may be reproduced