

PUBLIC WORKS TECHNICAL BULLETIN 200-1-87
3 MARCH 2011

**OPERATION AND MAINTENANCE FOR
CENTRAL VEHICLE WASH FACILITIES**

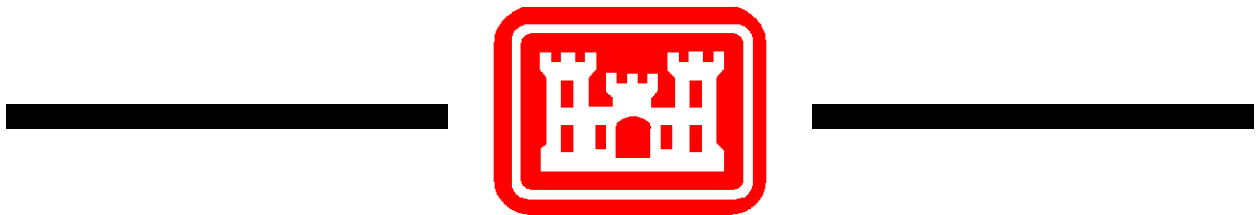

Public Works Technical Bulletins are published by the U.S. Army Corps of Engineers, Washington, DC. They are intended to provide information on specific topics in areas of Facilities Engineering and Public Works. They are not intended to establish new Department of the Army (DA) policy.

DEPARTMENT OF THE ARMY
U.S. Army Corps of Engineers
441 G Street NW
Washington, DC 20314-1000

CECW-CE

Public Works Technical Bulletin

3 March 2011

No. 200-1-87

FACILITIES ENGINEERING
ENVIRONMENTAL

OPERATION AND MAINTENANCE FOR CENTRAL
VEHICLE WASH FACILITIES

1. Purpose.

a. This Public Works Technical Bulletin (PWTB) provides general guidance for the operation and maintenance (O&M) of Central Vehicle Wash Facilities (CVWF) that were designed according to the guidance in Unified Facilities Criteria (UFC) 4-214-03 "Central Vehicle Wash Facilities." This PWTB can be used as a reference by CVWF operators and Directorate of Public Works (DPW) personnel. It may also be used as a reference for preparing the statement of work for a CVWF operation contract.

b. All PWTBs are available electronically (in Adobe® Acrobat® portable document format [PDF]) through the World Wide Web (WWW) at the National Institute of Building Sciences' Whole Building Design Guide web page, which is accessible through URL:

http://www.wbdg.org/ccb/browse_cat.php?o=31&c=215

2. Applicability. This PWTB applies to all U.S. Army DPW activities at installations where a CVWF exists.

3. References.

a. Executive Order (EO) 13514, Federal Leadership in Environmental, Energy, and Economic Performance, 5 October 2009.

b. Army Sustainability Campaign Plan (ASCP), May 2010.

3 March 2011

c. Technical Manual (TM) 5-814-9, "Central Vehicle Wash Facilities," February 1992.

d. Engineer Technical Letter (ETL) 1110-3-469, "Alternatives for Secondary Treatment at Central Vehicle Wash Facilities," 3 February 1995.

e. UFC 4-214-03 "Central Vehicle Wash Facilities," 16 January 2004.

f. PWTB 200-1-55, "Update to UFC 4-214-03 Central Vehicle Wash Facilities: Lessons Learned at CVWF's Since 1990," 1 April 2008.

4. Discussion.

a. EO 13514 establishes an integrated strategy towards sustainability in the Federal Government. The water conservation aspects of the CVWF make it an important contributor to that strategy.

b. ASCP will be the roadmap to align and integrate ongoing efforts to achieve sustainability with the new and necessary plans and programs to address the Department of Defense's objectives in implementing EO 13514. The continued use of existing CVWFs and the construction of new CVWFs will contribute to achieving the objectives of DOD's strategy regarding water conservation.

c. Headquarters U.S. Army Corps of Engineers (HQUSACE) published design guidance for CVWFs in 1992 in the form of TM 5-814-9, "Central Vehicle Wash Facilities." That guidance was based on: (1) research on wash water treatment conducted by the U.S. Army Engineer Research and Development Center, Construction Engineering Research Laboratory (ERDC-CERL) between 1977 and 1987; (2) experience at a few facilities designed and constructed by Corps Districts in the mid-1980s; and (3) washing requirements for the tactical vehicles being used in the mid-1980s.

d. Because the design guidance for the CVWF recycle treatment system needed additional refinement, USACE conducted additional studies between 1988 and 1993 at the first few CVWFs. The studies evaluated three alternatives for secondary treatment of wash water recycled at CVWFs: intermittent sand filtration, lagoon, and constructed wetland. The results of these studies were used to create ETL 1110-3-469, "Alternatives for Secondary

3 March 2011

Treatment at Central Vehicle Wash Facilities." The ETL contains planning and design guidance for each of the three secondary treatment alternatives.

e. In January 2004, TM 5-814-9 was replaced by UFC 4-214-03, "Central Vehicle Wash Facilities." The content of the UFC document is identical to TM 5-814-9.

f. PWTB 200-1-55, "Update to UFC 4-214-03 Central Vehicle Wash Facilities: Lessons Learned at CVWF's Since 1990" summarizes CVWF lessons learned and subsequent design variations that have been allowed during the 20 years following the preparation of TM 5-814-9.

g. While updates have been written for CVWF planning and design guidance documents, those documents contain little information regarding the O&M of CVWFs. This PWTB provides that guidance.

h. The CVWF is a pollution-prevention technology developed and implemented by USACE. The recycle treatment systems used at the more than 25 existing facilities collectively recycle an estimated 2.5 billion gallons of water every year. The first modern CVWFs were constructed in the early 1980s. Centralized wash facilities are still being constructed, primarily as a result of Base Realignment and Closure (BRAC) changes to installation training missions.

i. The CVWF is actually two systems: (1) a wash system of structures for washing tactical vehicles, and (2) a treatment system for treating the wash water for recycling. The wash system includes drive-through wash stations, bath prewash(es) (optional), and the necessary valves and controls to operate that system. The treatment system includes sedimentation basins, a sediment drying area (at some newer CVWFs), secondary treatment of either intermittent sand filters or lagoons, water storage in an equalization basin (if sand filters were used), and a storage basin for treated water to be recycled back to the wash structures.

j. One of the original goals of the CVWF concept was to minimize the effort and complexity of the O&M required. Washing is done by Soldiers manning hoses or water cannons rather than by complex, automated, washing equipment. The wash water is treated using the simple physical processes of sedimentation and sand filtration. Chemical treatment and advanced biological treatment processes were not used at CVWFs so that personnel

3 March 2011

responsible for O&M would not require special training. However, even simple systems such as those a CVWF comprises must be operated and maintained correctly in order to continue functioning for their intended purpose.

k. The wash system is operated so that vehicles can be quickly washed while still maintaining the safety of Soldiers using the facility. A small CVWF can be operated by one person, but larger CVWFs usually require a lead operator with two or more assistant operators. An operator's tasks include prewash briefings, starting/stopping pumps, controlling water levels in basins, and generally supervising the wash area. Maintenance of the wash system primarily consists of replacing worn items such as hoses and nozzles, and repairing mechanical items such as valves, pumps, and motors.

l. Operation of the treatment system generally does not require the same monitoring as the wash system. The treatment system is designed so that wash water will flow through the treatment structures without operator input. Activation of valves, pumps, etc. is controlled by timers and water-level sensors in the basins. However, the operator must be familiar with the treatment system's operation to determine when maintenance or repair is necessary.

m. The purpose of the treatment system is to remove contaminants from the recycled wash water. These contaminants, mostly soil particles and floating oil, accumulate in the basins and on the surface of filters, where they must be periodically removed. Proper management of the accumulated contaminants is critical to the performance of the recycle system.

n. Appendix A contains guidance regarding the function, operation, and maintenance of each system and system component. This guidance must be general in nature because each CVWF has been designed to support the specific mission needs of an installation or tactical organization. No two CVWFs are identical; each has varying layouts, components, and design details. Therefore, this PWTB does not include detailed instruction for O&M of an individual CVWF. However, Appendix A may be useful as the starting point for the preparation of an O&M guide for a specific CVWF.

o. Appendix B contains a list of acronyms and a glossary of terms used in this PWTB.

PWTB 200-1-87

3 March 2011

5. Points of Contact (POCs). HQUSACE is the proponent for this document. The HQUSACE POC is Mr. Malcolm E. McLeod, CEMP-CEP, 217-761-5696, or e-mail: Malcolm.E.Mcleod@usace.army.mil.

Questions and/or comments regarding this subject should be directed to the technical POC:

U.S. Army Engineer Research and Development Center
Construction Engineering Research Laboratory
ATTN: CEERD-CN-E (Gary L. Gerdes)
2902 Newmark Drive
Champaign, IL 61822-1076
Tel. (217) 373-5831
FAX: (217) 373-3430
e-mail: Gary.L.Gerdes@usace.army.mil

FOR THE COMMANDER:

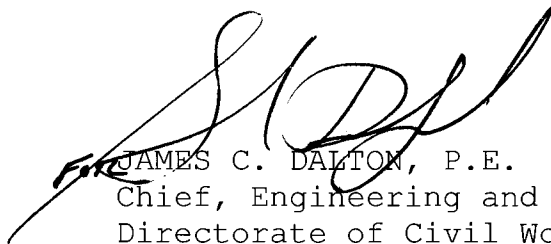

FIRE JAMES C. DALTON, P.E.
Chief, Engineering and Construction
Directorate of Civil Works

APPENDIX A:

**OPERATION AND MAINTENANCE OF
CENTRAL VEHICLE WASH FACILITIES**

CONTENTS

1.1 Purpose and Scope	3
1.2 Background	3
1.3 CVWF Operating Scenarios	4
1.4 Typical O&M Problems at CVWFs	5
1.5 Basic Responsibilities	6
1.5.1 User responsibilities	6
1.5.2 Operator responsibilities	6
1.5.3 DPW Maintenance Personnel responsibilities	7
1.5.4 DPW Environmental Personnel responsibilities	7
2.1 Standard Components - Washing	9
2.2 Standard Components - Wash Water Treatment	12
2.2.1 Primary treatment	12
2.2.2 Secondary treatment	14
2.2.3 Discharge to sewer	16
2.3 Water Quality	17
3.1 Washing Area	18
3.1.1 Prewash briefing	19
3.1.2 Bath prewash	20
3.1.3 Wash stations	29
3.1.4 Cold weather operation	32

3.2 Wash Water Treatment	32
3.2.1 Primary sedimentation basins	33
3.2.2 Equalization basin	39
3.2.3 Intermittent sand filters	41
3.2.4 Dosing basin	44
3.2.5 Lagoons	45
3.2.6 Water supply basin	45
3.3 Wildlife	46
3.4 Operating Log	48
4.1 Wash Area	49
4.1.1 Bath prewash	49
4.1.2 Wash stations	50
4.2 Wash Water Treatment System	51
4.2.1 Primary sedimentation basins	51
4.2.2 Equalization basin	60
4.2.3 Intermittent sand filters	64
4.2.4 Dosing basin.	69
4.2.5 Lagoons	69
4.2.6 Water supply basin	71
4.2.7 Support components (motors, valves, piping)	72
4.2.8 Maintenance log	72
4.2.9 Water quality	73

1 INTRODUCTION

1.1 Purpose and Scope

This Public Works Technical Bulletin (PWTB) is intended to be a general reference for the operation and maintenance (O&M) of Central Vehicle Wash Facilities (CVWFs) at U. S. Army installations. The guidance in this document is intended specifically for personnel who operate or maintain facilities that have been constructed according to the planning and design guidance in Unified Facilities Criteria (UFC) 4-214-03 "Central Vehicle Wash Facilities." (UFC 4-214-03 replaced Technical Manual [TM] 5-814-9 without change.)

While the planning guidance in UFC 4-214-03 has been followed for most CVWF designs, no two CVWFs are identical. Existing CVWFs vary in the design, size, and number of structures. There are variations in the layout of the facilities, the design of control panels, and the existence and placement of specific valves and pumps. Because of these variations, this PWTB cannot address all details of O&M for every CVWF.

Discussion of basic environmental issues is also included in this document. However, this discussion does not address State-specific requirements that may apply to a particular CVWF's operation. It is recommended that an installation prepare its own operation, maintenance, and environmental guide with additional detail specific to that installation's CVWF. Both the installation DPW and environmental organization should be involved in the preparation of this document to ensure that site-specific O&M details are addressed, and appropriate points of contact (POCs) are included. Operator input also would enhance the guide. This PWTB might be used as a starting point for the guide.

1.2 Background

The CVWF was developed specifically for cleaning Army tactical vehicles. The Army has unique vehicle cleaning requirements in terms of number and types of vehicles, washing time, and degree of cleaning that is necessary when units return from maneuver training exercises. The CVWF was developed to provide a means of expedient and cost-effective vehicle cleaning. The concept incorporates water conservation by including structures for the treatment and recycle of wash water.

3 March 2011

CVWFs have been constructed at all Forces Command and Training and Doctrine Command installations within the Continental United States that have maneuver training. More than 25 CVWFs have been constructed since 1980. An installation may refer to the CVWF by other names, such as Tactical Vehicle Wash Facility (TVWF), Tactical Vehicle Wash Rack (TVW or TVWR), or Central Vehicle Wash Rack (CVWR).

1.3 CVWF Operating Scenarios

In the past 30 years, CVWFs have been operated under five scenarios: (1) by post Range Division Civilians, (2) by post Directorate of Public Works (DPW) Civilians, (3) by post Directorate of Industrial Operations (DIO) Civilians, (4) by military personnel from a unit assigned CVWF responsibility, and (5) by contractors. Each option has advantages and disadvantages, as explained below. Most installations have tried two or more options.

(1) Operation by Range Division: This is the most logical group to operate the CVWF. Range Division is already responsible for scheduling the maneuver training areas – it is easy for them to coordinate a unit's use of a range, followed by use of the wash facility. Range Division personnel are sensitive to Soldier safety and to the challenges of supervising Soldiers using a large facility. Unfortunately, this option often has been abandoned due to personnel cuts.

(2) Operation by DPW: This is often the first option chosen when a CVWF initially starts up because the DPW will also perform maintenance on the facility. It is convenient to have the same organization operating and maintaining the facility. This option has also often been abandoned at installations due to cuts in personnel.

(3) Operation by DIO: This option is logical because DIO provides vehicle maintenance services and is familiar with vehicle cleaning requirements. However, DIO, like DPW, is in the business of providing services for the tactical units, not providing a facility that the Soldiers use themselves. Again, this option often has been abandoned due to cuts in personnel.

(4) Operation by military unit: This is the least expensive option, in the short term, because Soldiers can be detailed to operate the facility. Unfortunately, the Soldiers are seldom adequately trained, assigned operators are frequently reassigned or deployed, and the facility as a whole suffers from inadequate maintenance. Overall maintenance and repair costs tend to go up

3 March 2011

as a consequence of improper operation and inadequate maintenance.

(5) Operation by contractor: This is probably the most common method of current CVWF operation. If the contractor has a renewable contract, and the operators assume a feeling of "ownership" for the CVWF, this becomes a very good option. However, it may be more costly than operation by Department of Defense Civilians. Civilian operators can be reassigned to other tasks during periods of CVWF down time, while the contractors are paid whether the facility is operating or not. Also, contractors can become lax in their attention to employee training, capability, and performance.

As with most facilities, the quality of the operation depends on the quality of the operator's performance. It is important that the operators, no matter what organization they are from, are assigned to the facility long enough to develop familiarity and a sense of ownership.

1.4 Typical O&M Problems at CVWFs

When a CVWF first began operations, the operators were normally trained by the designer or construction contractor on the O&M of the facility. But over the history of any CVWF, operating personnel will have changed several times. Much of the original training information is lost in the transition from one operator to the next. Because of that loss, and because of a general lack of training on the O&M of each CVWF, poor and incorrect operating habits evolve.

Four areas of the operation of a CVWF are most often performed incorrectly. These are:

(1) The sedimentation basins are not operated in a way to efficiently capture the large amount of dirt and debris going into the basins when the bath is dumped.

(2) The recycle treatment system is allowed to become overfilled with excess water.

(3) The intermittent sand filters are operated incorrectly. The automatic filter dosing system is not kept operational and/or the filters are dosed manually with too much water.

(4) The surfaces of the intermittent sand filters do not receive adequate operator maintenance.

These and many other aspects of CVWF O&M are discussed in more detail in Section 3 (OPERATION) and Section 4 (MAINTENANCE) of this appendix.

1.5 Basic Responsibilities

Four groups are responsible for the efficient, safe, environmentally sound, and reliable O&M of a CVWF. These groups are: the tactical units using the facility, the operator(s), DPW Maintenance, and DPW Environmental. Suggested basic responsibilities of each group are listed below. These responsibilities are described in detail within section 3 (OPERATION) and section 4 (MAINTENANCE).

1.5.1 User responsibilities

- (1) Contact CVWF operator and set up an arrival time.
- (2) Comply with all signage. Follow guidance provided by the operators.
- (3) Move through the CVWF in an orderly manner.
- (4) Use personnel as ground guides to escort all tracked vehicles through the facility.
- (5) Observe general safety. Do NOT spray other Soldiers, waste water, or abuse the equipment and structures. Do NOT drink the wash water.
- (6) Do NOT perform any vehicle maintenance at the CVWF. Do NOT clean engine compartments. Do NOT use detergents.
- (7) Clean up the facility when finished washing. Put hoses back where they belong.

1.5.2 Operator responsibilities

- (1) Schedule the facility to accommodate the users' needs. Maintain a log of facility usage.
- (2) Conduct prewash briefings.
- (3) Control the pumps, valves, and bath water level as necessary for the users to wash vehicles. Prepare the facility in advance for scheduled users.
- (4) Monitor the activities in the wash areas to maintain correct and safe usage of the equipment.
- (5) Control flow into and out of the sedimentation basins as required for efficient treatment of the bath dump.

3 March 2011

(6) Monitor the operation of the recycle treatment system. Submit service orders for sediment removal. Scrape filter surface when needed.

(7) Observe the condition of all structures. Replace hoses and other wear items when needed. Submit service orders for repairs when needed.

(8) Maintain proper water levels in the treatment system. Notify DPW Environmental regarding pending discharges.

(9) Keep a log of all maintenance done by operator and DPW. Keep a record of significant events (accidents, fires, earthquakes, etc.)

(10) Establish normal operating hours to accommodate unscheduled washing. Vary hours as needed to accommodate scheduled washing.

(11) Ensure that all necessary signage is in place to maintain proper operation and maintenance of the facility. Submit service orders to maintain existing or add additional signage as needed.

(12) Keep the latrines orderly.

1.5.3 DPW Maintenance Personnel responsibilities

(1) Act on service orders submitted by the operators.

(2) Clean out sedimentation basins when needed.

(3) Ensure that the intermittent sand filters are being dosed correctly. Assist operator when maintaining the filter surfaces if necessary.

(4) Perform a thorough inspection of the facility semi-annually.

(5) Monitor operator performance.

1.5.4 DPW Environmental Personnel responsibilities

(1) Respond to requests for assistance from the operator regarding environmental compliance issues or operation of the treatment structures.

(2) Manage/obtain all necessary permits.

(3) Manage/perform all compliance assessments.

(4) Prepare sediment management plan and standard operating procedure for the removal and disposal of residuals generated by: cleaning the sedimentation basins, equalization basin, and other earthen basins; surface scrapings from the sand filters; and removal of sand from sand filters.

3 March 2011

(5) Manage the release of excess water from the recycle treatment system.

(6) Manage the disposal of oil and oily water that collects in the oil skimmer storage tanks.

(7) Perform necessary sampling and analysis for facility operation and compliance.

(8) Advise CVWF operator on the operation of the treatment system.

(9) Manage any wildlife issues involving the CVWF.

2 CVWF COMPONENT DESCRIPTIONS

2.1 Standard Components - Washing

The standard wash area at a CVWF consists of a vehicle preparation area, drive-through wash stations, a vehicle assembly area, and a control building. Figure A-1 shows an example of the site layout of a CVWF wash area having only the standard components.

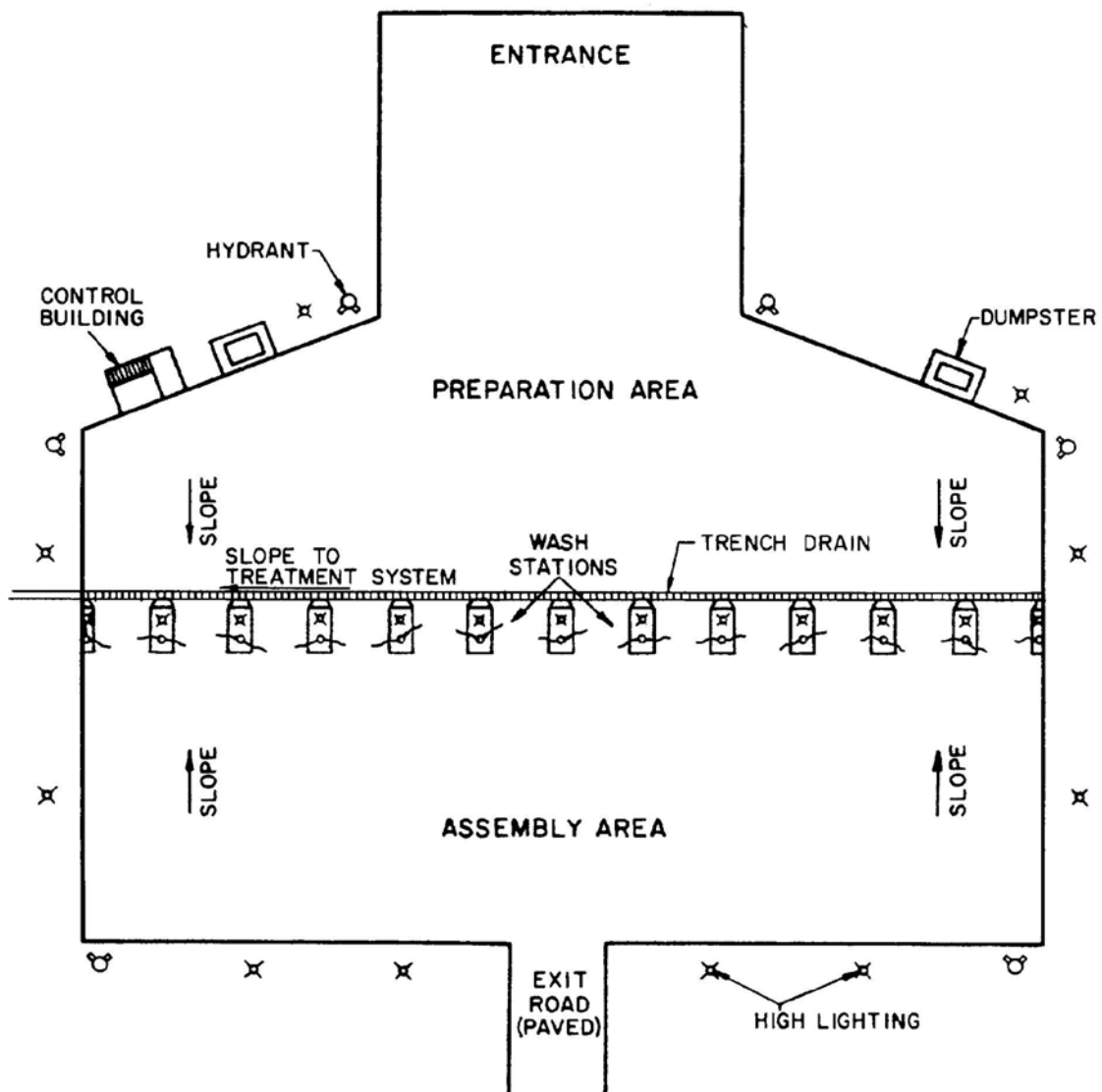

Figure A-1. Standard plan for a Central Vehicle Wash Facility (UFC 4-214-03, 2004).

3 March 2011

A bath prewash, or "bird bath" as it is often referred to, has been constructed at installations where vehicles become heavily soiled, where large numbers of vehicles are washed in one operation, and/or where washing time is limited. Baths were constructed with 1, 2, or 3 lanes. Large installations often required more than three bath lanes to meet washing requirements, so more than one bath was constructed at those CVWFs. Figure A-2 shows an example CVWF wash area layout with a bath prewash for tracked vehicles and large wheeled vehicles.

The layout of every CVWF is unique to its location. Structures were sited based on pre-construction site topography and other site conditions such as the location of utilities and roads. While no two CVWFs are identical, the basic operation is the same for all.

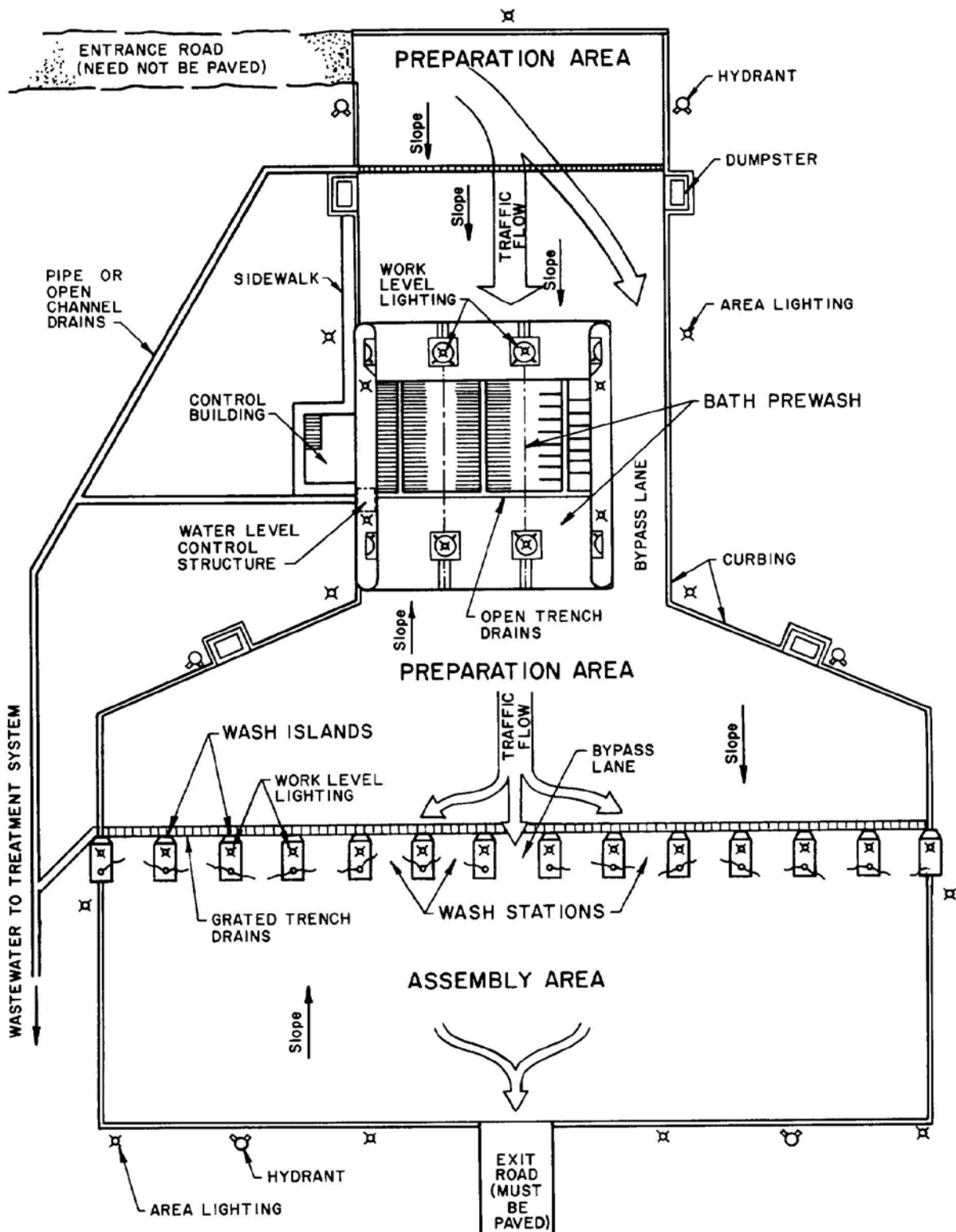

Figure A-2. Central Vehicle Wash Facility plan with bath prewash (UFC 4-214-03, 2004).

2.2 Standard Components - Wash Water Treatment

Because the water used to wash the vehicles becomes contaminated with dirt, debris, and small amounts of petroleum products, a system for conveying and treating wastewater is included in the CVWF. The CVWF treatment and wash water supply system also has several pumps and motorized valves and an electrical system to control them.

All waste wash water must receive primary treatment to remove settleable solids (soil particles) and floating material (oil, vegetation, and trash). Following primary treatment, the wastewater is either released to a sanitary sewer system or it goes through secondary treatment and is recycled.

2.2.1 Primary treatment

Primary treatment is provided by sedimentation basins where soil particles and petroleum products separate from the wastewater and accumulate in the basins. Floating vegetation and trash will also accumulate in the sedimentation basins. The waste materials that accumulate in these basins are removed and disposed periodically. Figure A-3 shows a plan drawing of a typical pair of sedimentation basins.

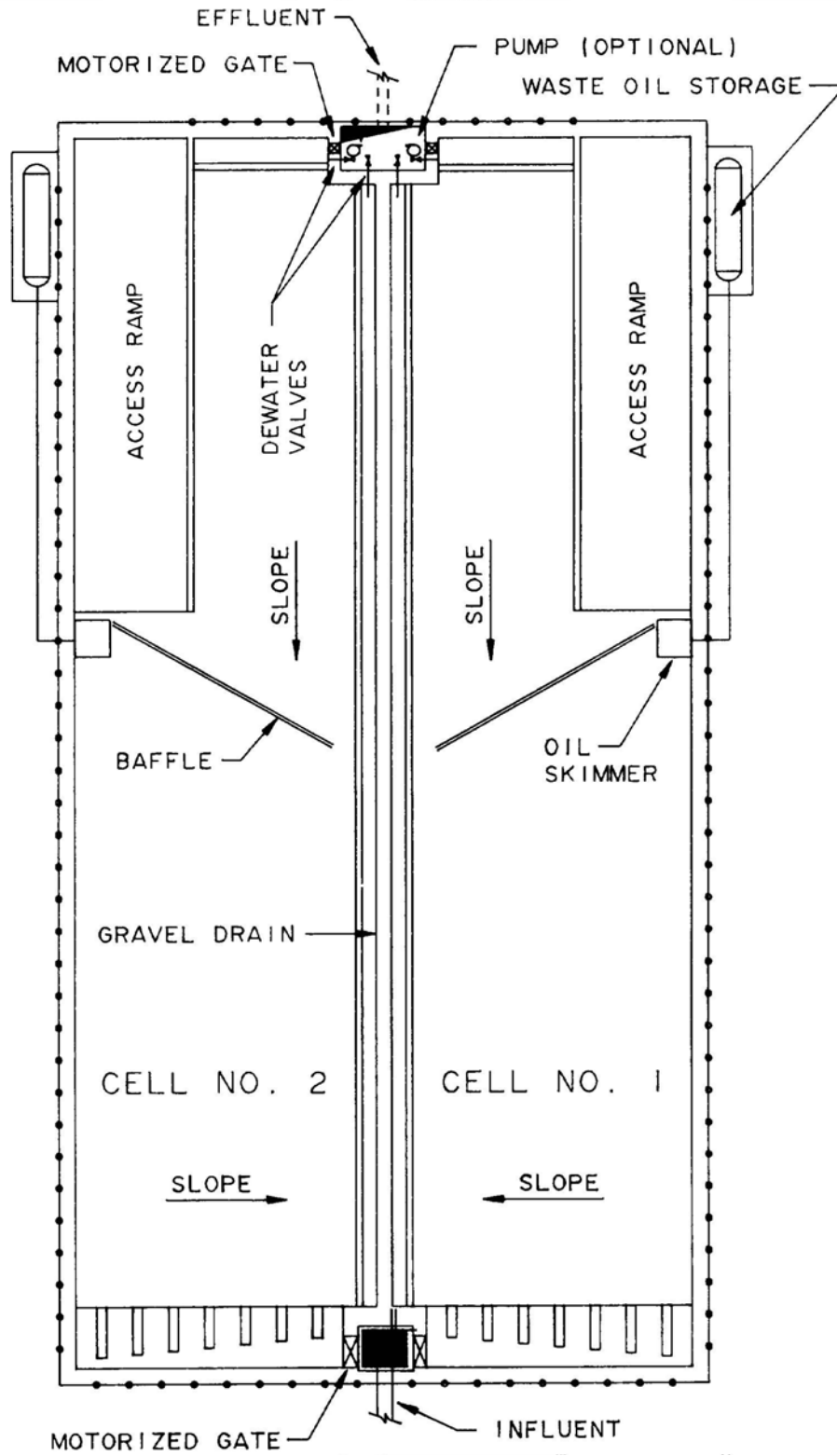

Figure A-3. Typical sedimentation basin plan
(UFC 4-214-03, 2004).

3 March 2011

2.2.2 Secondary treatment

At CVWFs where waste water is recycled, secondary treatment will follow primary treatment. The two types of secondary treatment systems in use are intermittent sand filters and lagoons. The systems and their components are described below. Further information on the O&M of these systems is found in Section 3 (OPERATION) and Section 4 (MAINTENANCE).

(1) Intermittent sand filter system. This secondary treatment system is comprised of an equalization basin, the intermittent sand filters, a dosing tank (at a few installations), and a clean water storage basin. Figure A-4 shows a flow schematic for a treatment system with intermittent sand filters.

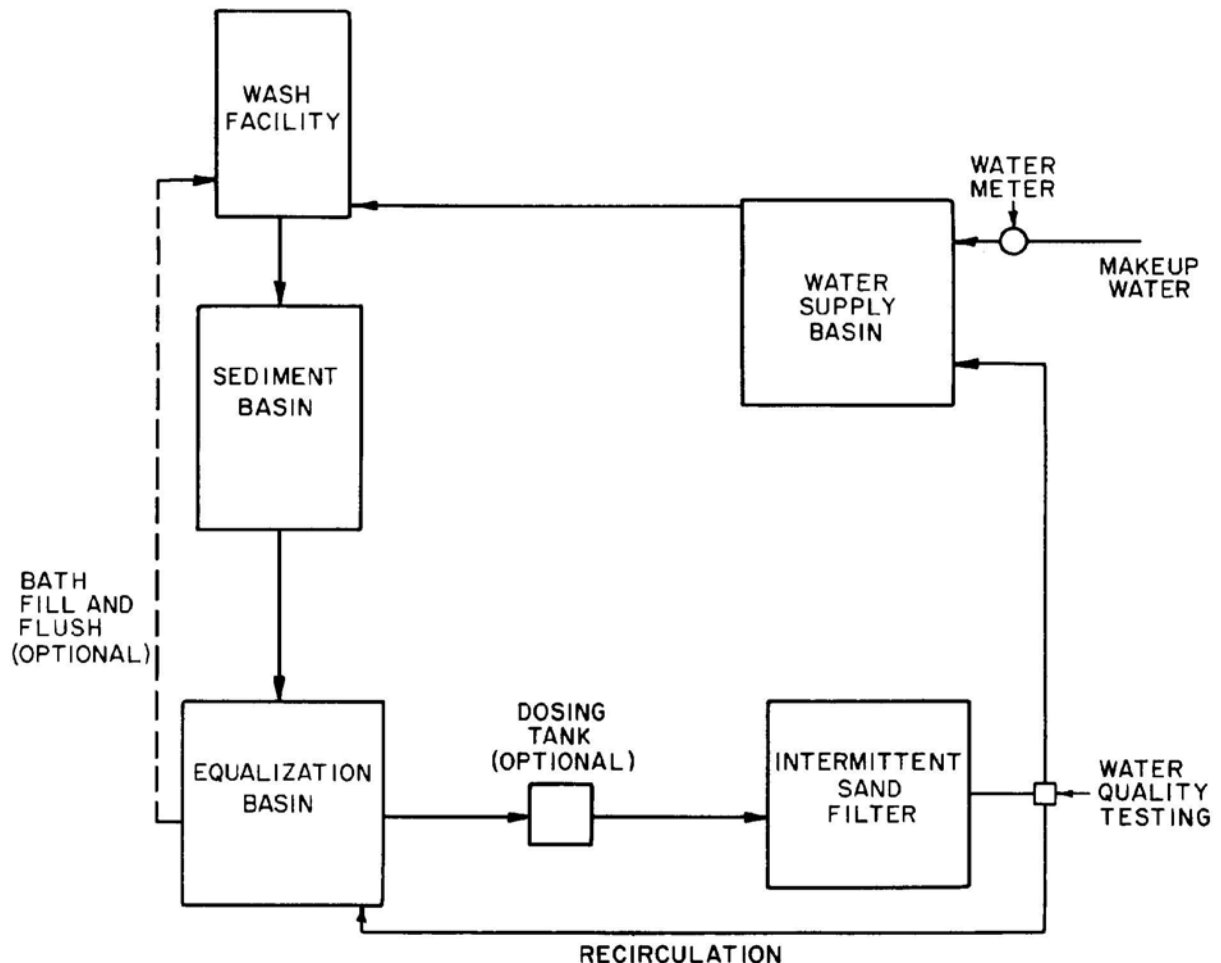

Figure A-4. Flow schematic of a CVWF treatment system with intermittent sand filters (UFC 4-214-03, 2004).

3 March 2011

The equalization basin accepts the wastewater after primary treatment and stores it until it is applied to the filters. The filters are sized to receive a specific volume of water from the equalization basin three times a day, up to 7 days a week. Because wash water flows from the wash areas at a high rate for relatively short periods of time, an equalization basin is used to spread that flow to the filters over a much longer period of time so the filters can be as small as possible. The intermittent sand filters are designed to filter water at a daily rate equal to the average daily rate at which wash water is generated at the wash areas. Filter dosing is controlled by an automatic dosing system that relies on timers and level sensors. Filter dosing is not intended to be done manually by the operator.

At a few CVWFs, a dosing tank has been installed downstream from the equalization basin. The volume of the dosing tank equals the amount of water for one dose to a sand filter. Water flows by gravity or is pumped from the equalization basin to fill the dosing tank. Valves and pumps for filling the dosing basin are controlled by water level sensors (usually float switches). The dosing tank empties onto a filter by gravity through valves controlled by timers.

Effluent from the intermittent sand filters is discharged to a water supply basin for storage. Water is pumped from this basin to the wash area. If makeup water is needed in the system, it is normally added to this basin.

The water stored in the recycle system is either in the supply basin or the equalization basin. Both basins should not be full at the same time in order for one basin to receive water (indirectly) from the other. After a long period of inactivity at the wash structures, all of the water in the equalization basin will have gone through the filters and filled the supply basin, leaving only enough water in the equalization basin for future bath fills. After several days of continuous washing, the supply basin may be drawn down and the equalization basin will be filled.

(2) Lagoon system. This secondary treatment system consists of an earthen basin or a series of basins where the wastewater is held for an extended period of time so that contaminants can: settle, float to the surface, and/or biologically degrade. Water exits the lagoon, usually by gravity flow, and goes to the water supply basin for reuse. Figure A-5 shows a flow schematic of a CVWF with lagoon treatment.

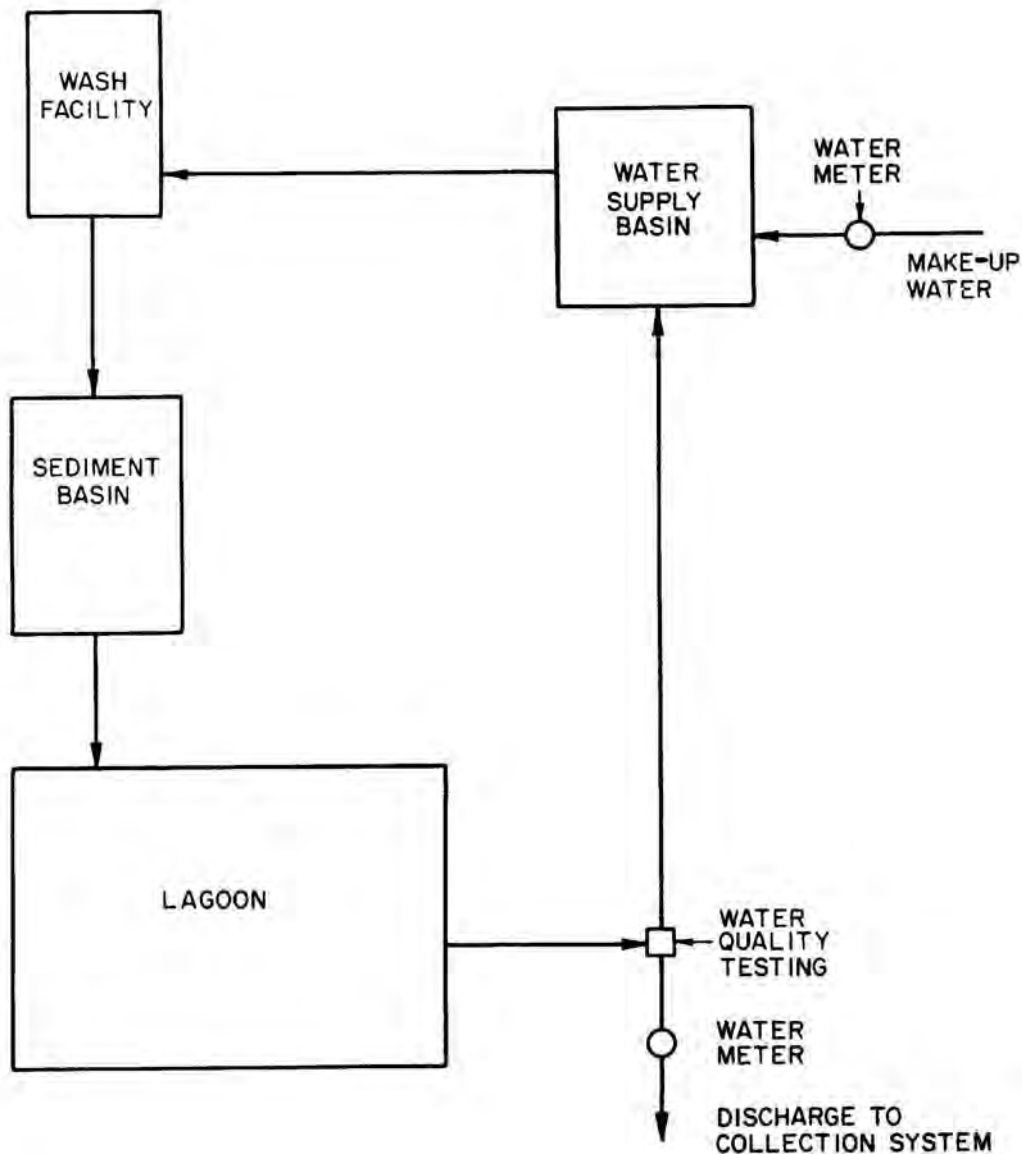

Figure A-5. Flow schematic of a CVWF with lagoon treatment (UFC 4-214-03, 2004).

2.2.3 Discharge to sewer

A third possible destination for pre-treated wash water is its discharge to a sanitary or industrial sewer. This option has been implemented at very few installations because, without recycle, the CVWF becomes a significant burden on the post water supply. The environmental compliance aspects of discharging to a sewer will be discussed in the next section (OPERATION).

3 March 2011

Many recycle systems have connections to a sewer system that is used for specific events. The most common of these events are (1) replacing recycled water with fresh water to decrease the dissolved solids concentration or (2) discharging excess water from the recycle system.

2.3 Water Quality

If the CVWF normally discharges water to a sanitary sewer system, then water quality testing will almost always be necessary. This testing would be required by the receiving treatment system, which can be either a government-owned on-post system, or a public system on or off post. The receiving treatment system will specify the required water quality and monitoring requirements. Meeting these requirements will be managed by the installation's DPW environmental organization. It is important that the treatment structures are operated and maintained properly in order for the CVWF to be in compliance with water quality discharge standards.

Monitoring water quality is also recommended at CVWFs with recycle treatment systems. This is done for the reasons given here:

- Good water quality is necessary to protect Soldiers who will use the CVWF and will be in contact with the water. While the recycle water is not potable, Soldiers may inadvertently ingest small amounts.
- There may be instances when it is necessary to discharge water from the recycle system to a sewer system or to the environment. This discharge may be done to prevent the buildup of dissolved material in the recycle water or to prevent the system from becoming overfilled by rain water. These discharges must be approved and monitored by the installation's DPW environmental organization.
- It is valuable to test the recycle water to ensure that suspended solids have been removed. It is desirable to keep the concentration of suspended solids in the clean water basin at 30 milligrams per liter or less. This will help to maintain the usable life of various components of the system, including valves, pumps, and nozzles.

Water quality and discharges from the CVWF are discussed further in sections 4.2.6 Water supply basin and 4.2.9 Water quality.

3 OPERATION OF CVWF

The tasks involved in operating a CVWF vary from supervision of washing exercises to making sure the automated treatment system is functioning properly. The number of personnel necessary to operate a CVWF varies according to the size of the facility and amount of control/supervision that needs to be exhibited at the wash areas. Small facilities with no bath prewash can function with a single operator. Large facilities with multiple bath lanes may need three or more persons for adequate facility supervision. In this document, the term "operator" refers to the on-site CVWF supervisor; although any of the operator's described tasks may be performed by a member of his crew.

Following are descriptions of operator tasks as they relate to the functions of the various CVWF structures. The sequence of the following paragraphs generally follows the vehicles as they progress through the wash area and then follows the wash water as it flows through the recycle system.

3.1 Washing Area

The steps that a unit takes when using the wash area are as follows:

- The unit will contact the operator to schedule when they want to use the wash facility. It is up to the operator to make sure there is no overlap with other units' scheduling, and to make sure the unit schedules enough time for entry, washing, and cleanup.
- The vehicles usually arrive at the facility directly from a maneuver training area. The vehicles line up outside the CVWF entrance along a tank trail or roadside.
- A CVWF operator performs a prewash briefing.
- Vehicles enter the facility and proceed to the wash structures. Tracked vehicles and large wheeled vehicles line up behind the wash lanes of the bath prewash (if one exists). All other vehicles proceed to the wash island lanes. Ground guides escort the vehicles while in the wash area.
- Vehicles exiting the bath proceed to the wash island lanes for final cleaning.

3 March 2011

- After vehicle washing is completed, the unit may re-form at the exit, or individual vehicles may proceed directly back to their motor pool.
- When all vehicles from the unit have been washed, personnel who are normally designated by the unit Officer in Charge (OIC) or Non-Commissioned Officer in Charge (NCOIC) will remain to clean up the facility.

3.1.1 Prewash briefing

The operator normally holds a prewash briefing at the entrance to the facility, though operators may wish to have the briefing near the control building. The briefing may be addressed to the unit commander(s) or to a larger group of vehicle drivers. Written instructions should be available for first-time users of the facility. The purpose of the briefing is to inform the Soldiers on how they are to use the facility. The briefing would include: (1) a description of the washing area, (2) an explanation of what washing structures are in use, (3) how the vehicles are to proceed through the wash process, (4) how to use the hoses and water cannon, (5) an explanation of the check-out and return of hoses, brushes, brooms, etc., and (6) the cleanup of the area prior to the unit exiting the CVWF. The briefing will explain that soaps and detergents are not allowed at the CVWF. It is important that the operator instruct Soldiers to turn off hoses and cannons when they are not in use to minimize flow through the recycle treatment system and make it more efficient.

The prewash briefing also will address safety measures taken at the CVWF. Those safety measures should minimally include: (a) a ground guide will be used from when a vehicle enters the facility until it exits; (b) water cannons will not be sprayed directly at personnel, at wheeled vehicle windshields, nor at the air intakes of tracked vehicles; (c) all hoses at the wash islands will not be directed at personnel (particularly any high pressure hoses, if they exist); and (d) the treatment structures are generally off-limits to Soldiers using the facility.

The operator should advise the NCOIC or OIC that Soldiers must be assigned to man water cannons at the bath, and that they are to remain at the cannon after the washing of their unit's vehicles to clean up the facility.

3.1.2 Bath prewash

(1) Description: The bath prewash is a shallow basin of water through which tactical vehicles are driven to loosen the dirt and debris attached to the wheels and undercarriage. Each lane of the bath prewash has four fixed water cannons, one on each side of the lane's entrance and exit.

The concrete bottom of each bath lane has steel pipe embedded to raise the vehicle above the mud that accumulates in the bottom of the bath. The pipes (called flexors) also cause the vehicle's wheels or tracks to move up and down as it drives through the lane. This is intended to agitate the water and create a washing machine effect that will loosen the dirt. Tracked vehicle lanes have large flexors that are spaced 5.5-6 feet (ft) apart. The flexors on each side of the lane are offset to cause a slight rocking of the vehicle in order to increase agitation in the water. Dual-purpose lanes, which can be used by both tracked vehicles and large wheeled vehicles, have smaller flexors embedded in the bottom with closer spacing (12-18 in.). These flexors are not offset so that wheeled vehicles can be better controlled.

Many different combinations of tracked and multi-use lanes have been used at the various bath prewashes across the country. Figure A-6 and Figure A-7 show an example of a three-lane bath design and the cross section of a tracked bath lane. Figure A-8 shows the baths at Yakima Training Center, and Figure A-9 and Figure A-10 show tracked and multi-use flexors at that facility.

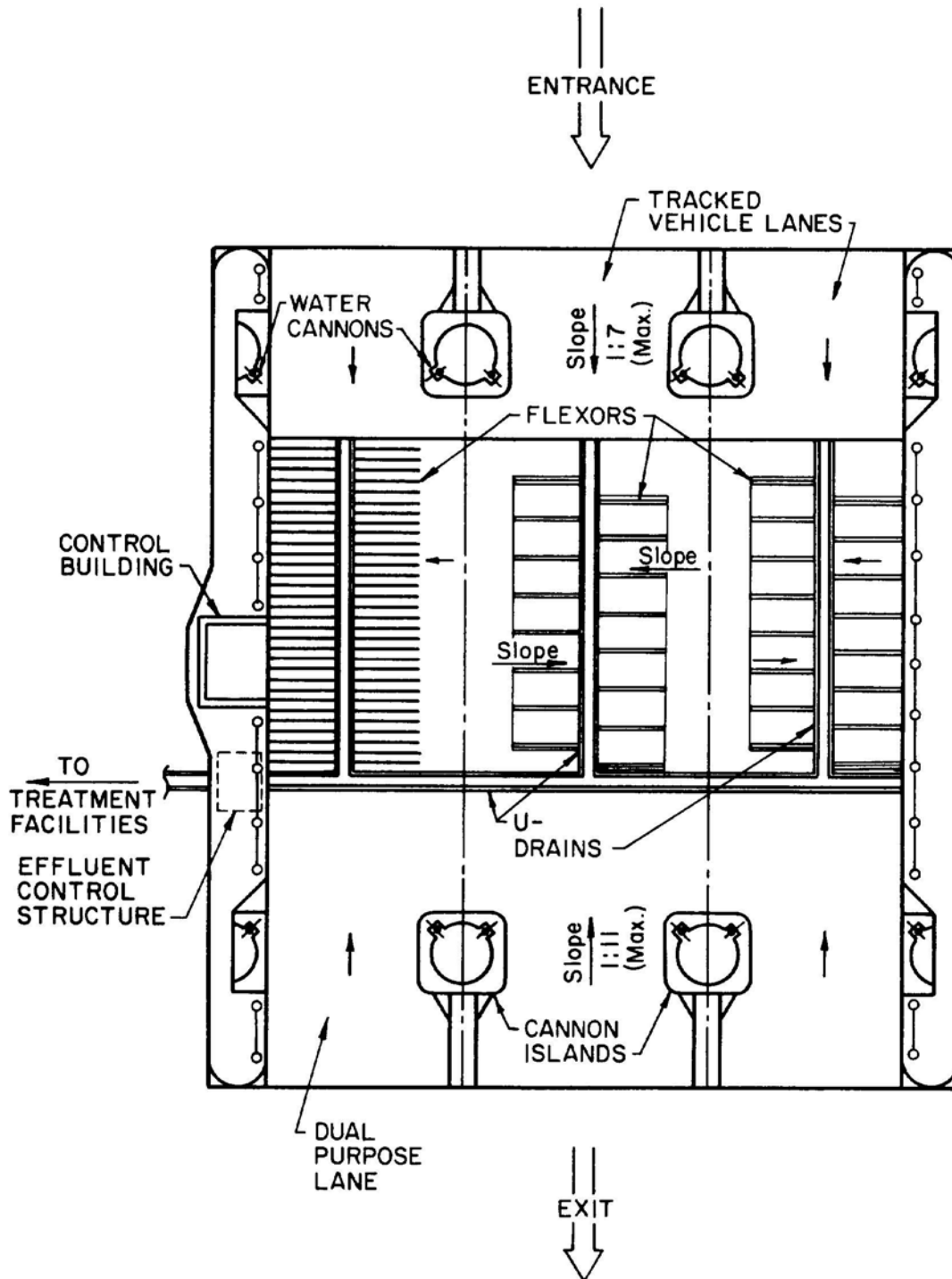

Figure A-6. Example of bath layout with two lanes for tracked and one lane for dual-purpose vehicles (UFC 4-214-03, 2004).

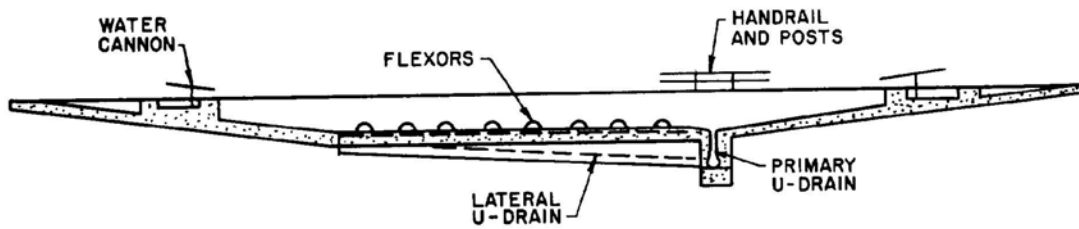

Figure A-7. Cross section of a typical tracked vehicle bath lane (UFC 4-214-03, 2004).



Figure A-8. Three two-lane baths at Yakima Training Center CVWF (photo by ERDC-CERL).



Figure A-9. Offset flexors in tracked-vehicle lane at Yakima Training Center CVWF (photo by ERDC-CERL).



Figure A-10. Dual-purpose lane flexors at Yakima Training Center CVWF (photo by ERDC-CERL).

(2) Washing: Tactical vehicles drive back and forth several times through the bath in order to allow enough time for water agitation and soaking to loosen the dirt. Soldiers are assigned by the unit to man each cannon. Each Soldier directs water from

his cannon at the vehicle as it enters or exits the water in the bath. The water cannon spray stream should always be directed toward the bath when the vehicle is just exiting the water, so that the mud removed from the vehicle is easily washed into the bath water. Figure A-11 shows a water cannon aimed at the tracks of an M-1 tank as it is being towed through a bath. Soldiers should turn off their cannons when not washing. Appropriately large signage near the bath should instruct soldiers that turning off canons and hoses when not in use will help the recycle system.

A vehicle may spend up to 10 minutes (min) in the bath before exiting and proceeding to the final wash lanes. The vehicle's ground guide or the cannon operators should determine when the vehicle is clean enough to proceed to the final wash stations.

While in the bath, the driver of a tracked vehicle has limited visibility and should depend on his ground guide. It is common practice for the ground guide to direct a vehicle in the bath while he is standing at the top of the exit ramp.



Figure A-11. An M-1 tank being towed through a bath (photo by ERDC-CERL).

(3) Operating depth: The bath has a maximum depth of 3-4 ft. The water level is controlled by the operator, but the depth that is set is normally chosen by the unit using the facility. (Every unit seems to have their own notion of what the ideal operating depth should be.) That being said, 4 ft is too deep for most vehicles, especially wheeled vehicles. A Bradley M2 or M3 Infantry Vehicle will float at that depth. A depth of 3 ft is good for M1 tanks. Because large wheeled vehicles are seldom waterproof, it is best not to set the water depth above the bottom of the vehicle's doors.

Depth is usually controlled by a manually operated overflow sluice gate. Some facilities may have a motorized valve, and possibly a depth sensor, to control and monitor the depth. In that case, the depth would be input at the control panel in the operator's room. Figure A-12 shows a typical water-level control structure.



Figure A-12. Water level control structure
(photo by ERDC-CERL).

3 March 2011

(4) Filling the bath: The fill and flush water for the bath is pumped from either the treated water storage basin or from the equalization basin. The operator initiates bath fill from the control panel by turning on the fill/flush pumps. Normally the bath will continue to fill until the operator turns off the fill pumps. At some installations, the bath fill function may be automatically controlled. A three-lane bath can usually be completely filled in a period of 45-60 min. If multiple baths are being filled, then a proportional amount of additional time will be needed to fill all of the baths. Normally an operator will fill the bath before the tactical unit arrives.

Embedded below the concrete bottom of the bath are U-drains (also called trench drains) for emptying the bath of water and accumulated sediment. The U-drains are sloped to a common outlet from which the wash water flows to the treatment system (see Figure A-6). Figure A-13 shows a typical cross section of a U-drain. At the beginning of each U-drain is a pipe from which the fill and flush water enters the bath.

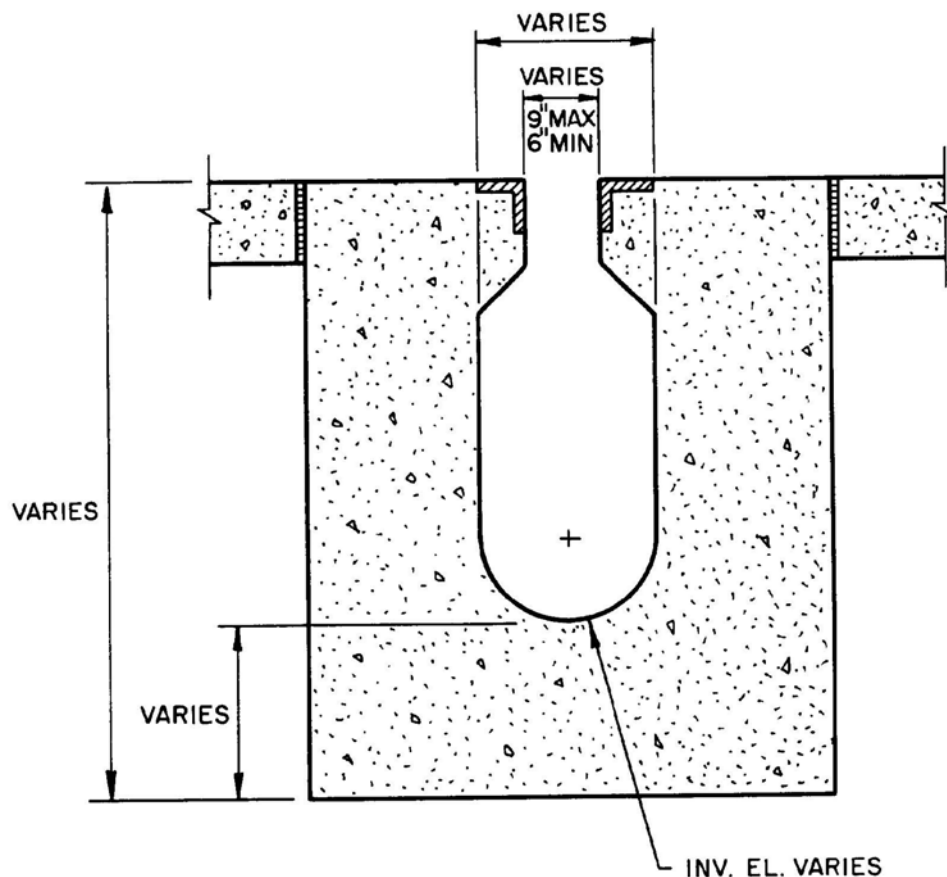

Figure A-13. Cross section of a typical U-drain (UFC 4-214-03, 2004).

3 March 2011

(5) Draining the bath: The bath must be drained and refilled after a large number of vehicles have been cleaned, because dirt eventually will fill the space between the flexors, and the vehicles will begin to carry it out of the bath. The amount of soil carried on the vehicles determines how many can be washed in one bath fill. Usually 30-40 vehicles per lane can be washed before the bath should be drained, cleaned, and refilled.

The operator determines when the bath should be drained. Often the operator will require the bath to be drained after each unit passes through the facility. However, if the next unit on the schedule is willing to accept the bath "as is," then they can begin using the bath immediately without having to wait for the bath to be drained and cleaned out.

The operator initiates emptying the bath (also called the "bath dump"). The bath dump begins by simply opening the outlet valve, which is part of the effluent control structure. The control panel may have a switch that activates a bath dump sequence. The operator, or the automated control system, will then turn on the fill/flush pumps. It is not necessary to turn on the pumps right away, as the water exiting the bath will tend to carry with it much of the sediment that had collected in and around the U-drains. The fill/flush pumps should be turned on when the water in the bath has drained to a level even with the top of the flexor pipes. It should take 10-30 min for the bath to empty.

(6) Cleaning the bath: Most of the dirt on the tracked vehicles and large wheeled vehicles is washed off in the bath. The fine soil particles tend to stay suspended in the bath water and eventually overflow the level-control weir. Larger soil particles tend to settle to the bottom of the bath. When the bath is dumped, some of the sediment in the bottom is carried away by the bath water. However, much of the sediment remains in the bottom of the bath between the flexors (see Figure A-14). This sediment must be washed out manually. Normally this task is assigned to Soldiers from the unit using the CVWF. Much of the sediment can be washed into the U-drains using the water cannon or pushed into the U-drains using flat edged shovels. (The fill/flush pumps must remain on and the bath drain valve remain open during the bath cleanout.) The remaining sediment is washed out by Soldiers using hoses. Hose connections are usually provided at the water cannons or at nearby hydrants. The bath can be drained and cleaned by a crew of four or more Soldiers in about an hour.



Figure A-14. Drained bath prior to a cleanout
(photo by ERDC-CERL).

3 March 2011

After the bath has been drained and cleaned, the operator should inspect the drain valve. This is usually a large butterfly valve in the overflow structure, placed at the end of the main trench drain. Vegetation washed from vehicles using the bath tends to collect on the butterfly valve. The vegetation should be removed prior to closing the valve for the next bath fill. Power to the motor actuating the valve should be turned off for safety prior to removing the debris.

3.1.3 Wash stations

All of the dirt on small vehicles and the remaining dirt on prewashed vehicles is washed off at the wash stations. A wash station is a drive-through lane where each vehicle can be washed by one or two Soldiers manning hoses. Concrete islands that separate the wash lanes are the location for the hose towers, hose control valves, and lighting (Figure A-1, Figure A-2, Figure A-15, and Figure A-16). The hose towers are sometimes equipped with swing arms (the beams in Figure A-15) that make it easier for the hoses to reach the full length of the vehicle. At some installations, the swing arms have been removed because of structural concerns, and the hoses are attached to a pipe at the top of the tower. Figure A-17 shows M-1 tanks being washed at wash stations.

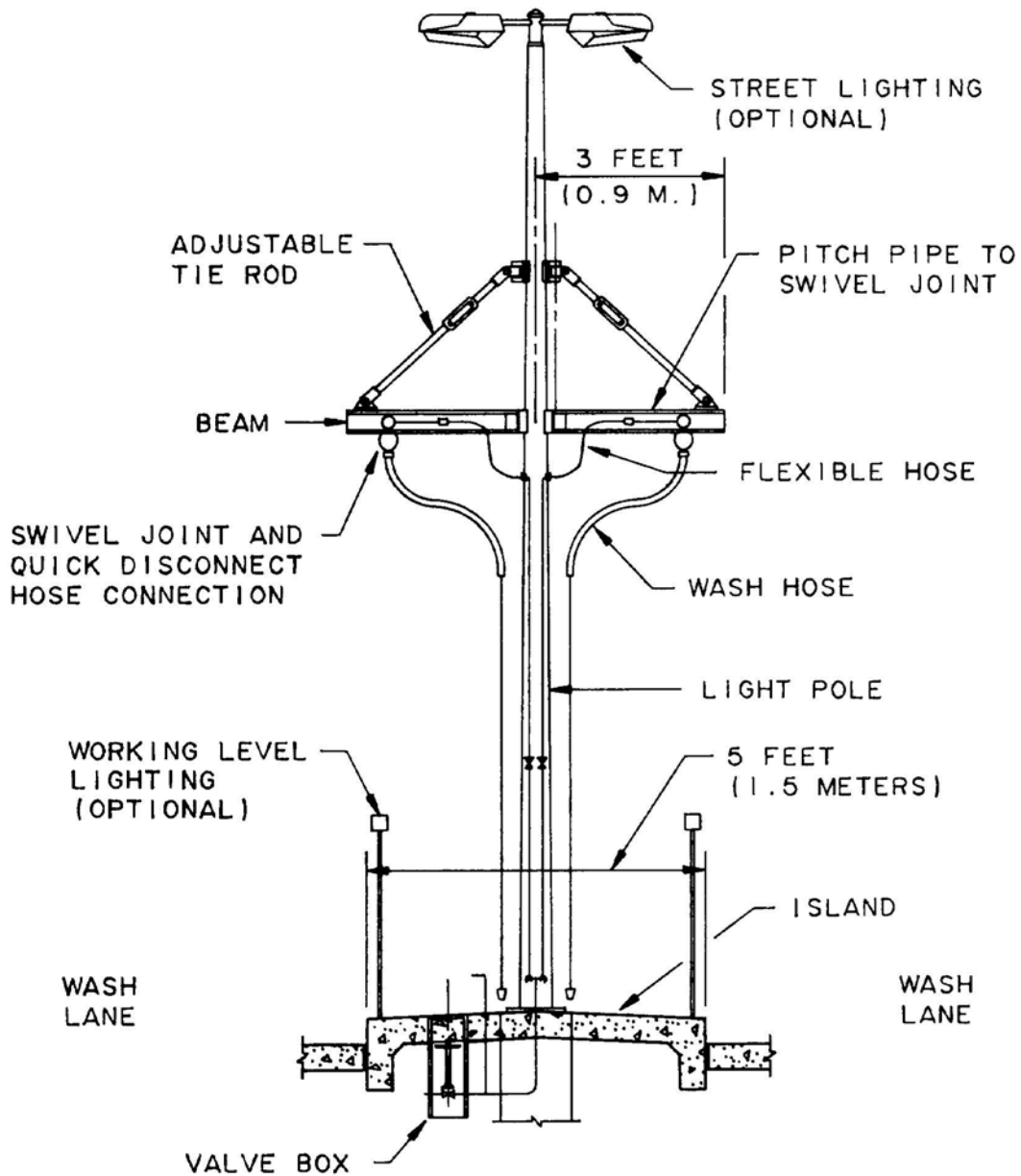

Figure A-15. Wash tower island cross section (UFC 4-214-03, 2004).

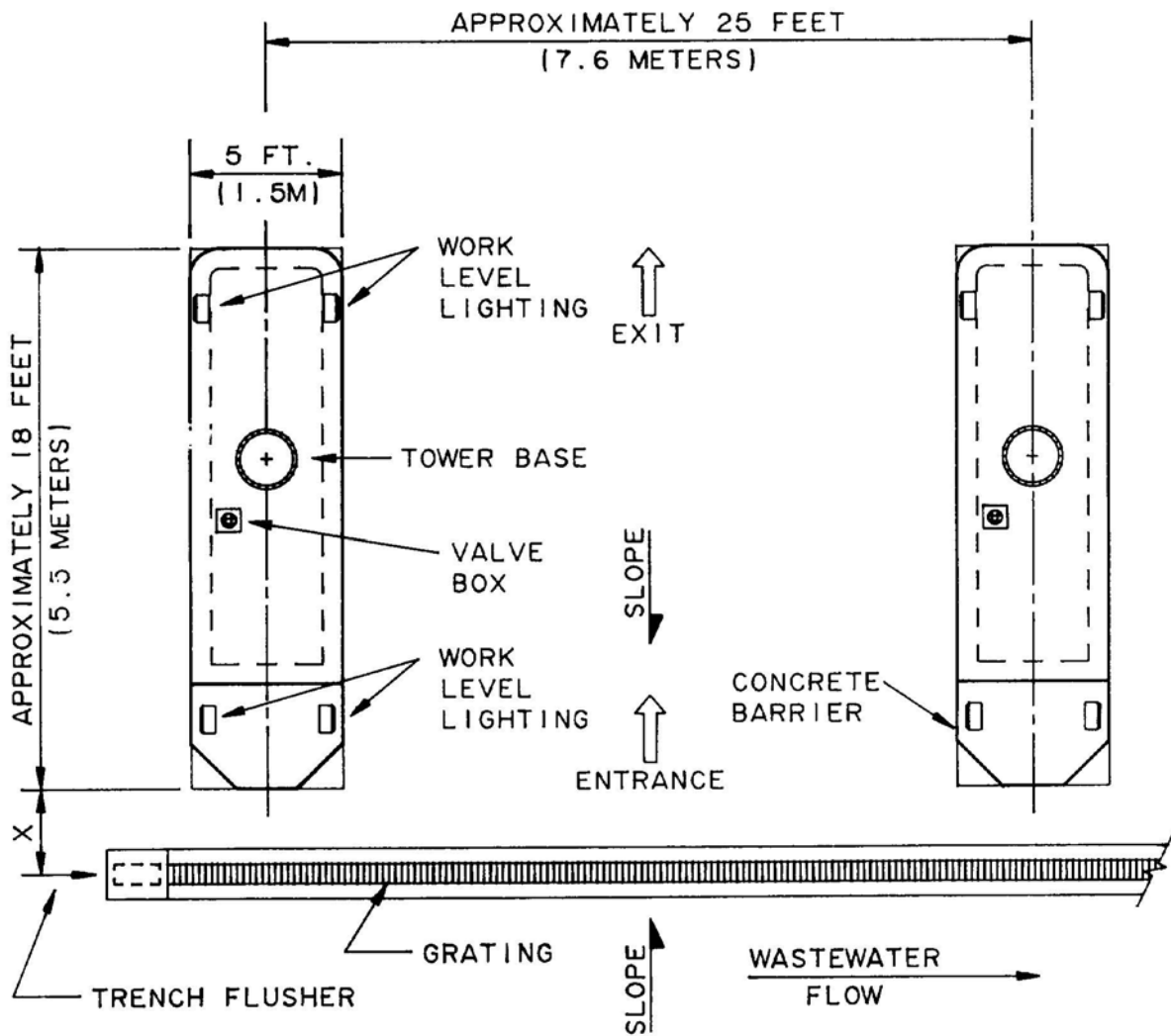

Figure A-16. Plan showing wash lane, with a tower island on either side (UFC 4-214-03, 2004).



Figure A-17. M-1 tanks at wash stations (photo by ERDC-CERL).

After a vehicle is washed, the Soldier is to clean up the dirt left on the pavement by washing it into the drain system. A trench drain, usually covered by a grate, collects the wash water from the line of wash stations. Additional water from a flusher at the end of the trench drain helps the waste wash water flow to the wash water treatment system.

3.1.4 Cold weather operation

Normally it is best to close a CVWF when the temperature is below freezing. Water freezing on pavement creates hazardous conditions for vehicles and Soldiers moving about the facility. Extended periods of below freezing temperatures can cause damage to CVWF pipes, valves, and pumps. If temperatures are predicted to fall below freezing following a wash event, the operator should open all valves on the wash hoses and water cannons to allow the system piping to drain down. Any valves in the pump buildings must also be opened to drain down the system.

3.2 Wash Water Treatment

Much of the wash water treatment system is automatically controlled by water level switches and pump timers. Unlike with wash operations, the operator normally does not need to be constantly involved in the treatment system when it is

3 March 2011

operating. However, the operator must monitor the treatment system to make sure it is functioning properly, to make sure water levels in the system are appropriate, and to know when maintenance is required. Following are descriptions of the operation of each CVWF component: sedimentation basins, equalization basin, sand filters, lagoons, dosing basin, and water supply basin.

3.2.1 Primary sedimentation basins

All wash water is piped directly to rectangular concrete basins called sedimentation basins. The daily operation of the sedimentation basin is quite simple: wash water flows into the influent end, slowly passes through the basin during a period of 2-4 hr, and then exits the effluent end after leaving behind the majority of soil particles and oil carried from the wash areas. Every CVWF has two basins that operate in parallel so that one basin can continue to function when the other basin is being serviced. A basin is taken out of service to remove the sediment that accumulates in the bottom.

(1) Splitter box: At the end of the pipe bringing wash water from the wash areas is a concrete structure called a splitter box with valves or gates that are set by the operator to either divide the influent flow between the two basins or to direct the flow to a single basin. Figure A-18 shows parallel sedimentation basins with the splitter box structure in the foreground.



Figure A-18. Sedimentation basins with splitter box in foreground (photo by ERDC-CERL).

3 March 2011

(2) Inlet structure: A trough-like structure may be located at the influent end of each basin to distribute the incoming flow across the width of the basin (Figure A-19). Many basins do not have this feature and simply have flow from the wash area entering each basin from a single pipe (Figure A-20). Regardless of the type of structure, the operator should monitor the inflow to make sure there are no blockages that will cause wash water to back up into the influent pipe.



Figure A-19. Trough-like sedimentation basin inlet flow distribution structure (photo by ERDC-CERL).

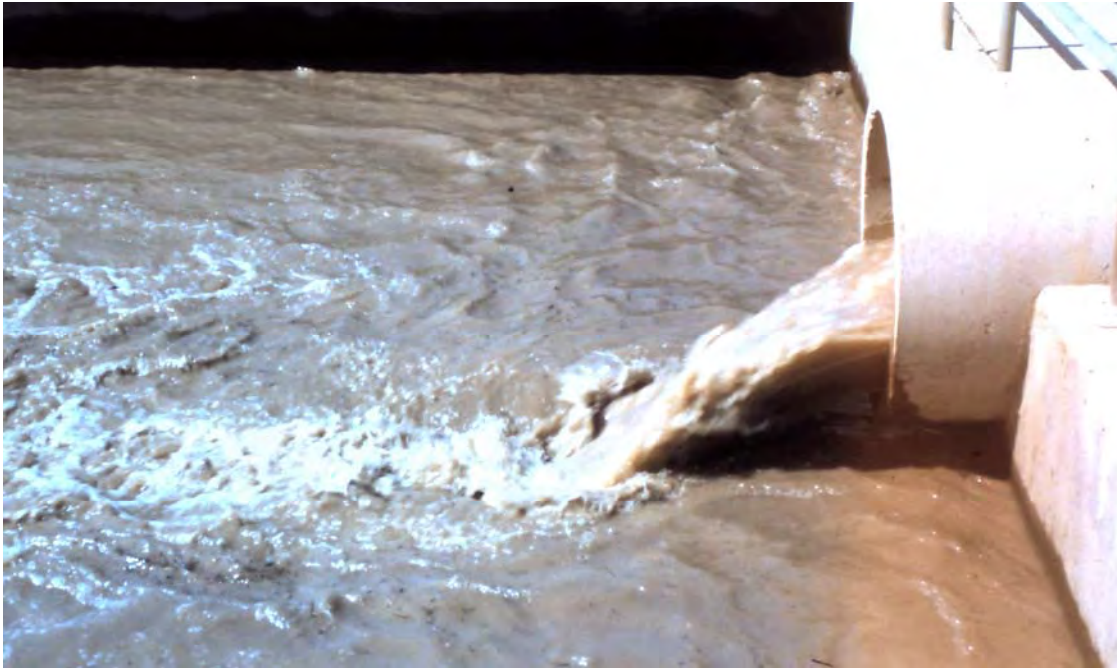

Figure A-20. Sedimentation basin inlet (photo by ERDC-CERL).

(3) Entrance ramp: To remove accumulated sediment, an entrance ramp allows earth moving equipment access to the bottom of the basin. The ramp may be at either end of the basin. The ramps can be seen at the outlet end of the basin in Figure A-18.

(4) Overflow structure: The outlet end of each basin has an overflow structure where the treated wash water exits the basin. This structure may simply be a trench drain in the entrance ramp. Other facilities have an overflow weir. Just upstream of the overflow structure is a baffle to prevent floating oil and other material from exiting the basin. The baffle may be a floating type or a rigid beam. All wash water flows under the baffle. There may also be a net across the basin to help keep vegetation from overflowing it. During wash events, the operator should monitor the operation of the outlet structures to make sure that no blockages interfere with the outflow. Figure A-21 shows a typical outlet structure configuration.

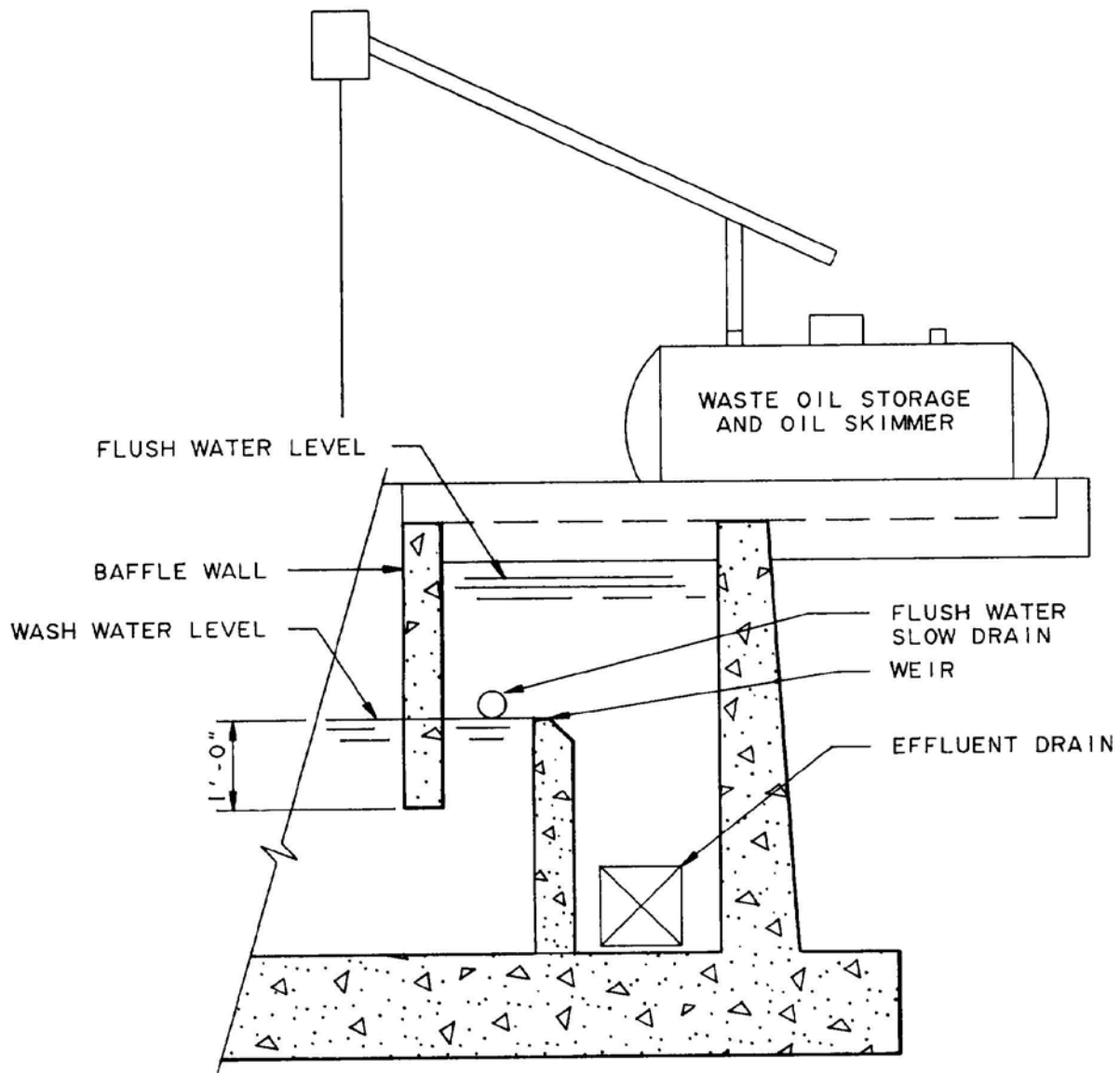

Figure A-21. Example cross section of an outlet structure (UFC 4-214-03, 2004).

(5) Oil skimmer: Most sedimentation basins have one or two oil skimmers to remove floating oil from the surface of the water. Use of these skimmers depends on the presence of oil and the wind direction. The operator should turn off the oil skimmer if no floating oil can be seen in the basin, or if the wind has blown the floating oil away from the skimmer. Many facilities have abandoned the oil skimmers because they are not needed at those sites. Unless floating oil covers over 100 sq ft of water surface under the skimmer and that area is increasing in size, it may remain turned off. Figure A-22 shows a typical floating tube oil skimmer.



Figure A-22. Floating tube oil skimmer (photo by ERDC-CERL).

3 March 2011

(6) Mode of operation for bath dump is as follows. Operation of the sedimentation basins at CVWFs with bath prewashes requires an operator's attention. When a bath prewash is emptied, flow to the sedimentation basins increases greatly. This creates a great amount of turbulence in the basin and tends to stir up soil that has already settled. Water quality at the effluent end of the basin is very poor following a bath dump.

To prevent large amounts of soil from passing through the sedimentation basins following a bath, the operator should take measures to improve treatment of the bath dump water. These measures involve stopping the flow exiting one or both basins for 2 hr during and after the dump. There are two basic options to treat the bath dump.

Option 1: Close the outlet from the basins and use the available freeboard to store the bath dump water. (See Figure A-21.) This option can be used only if the sedimentation basins have enough freeboard to contain the bath dump and subsequent wash down water. Just prior to dumping the bath, the operator closes the valve(s) on the outlet(s) to one or both basins. After the bath is completely dumped, the valves remain closed for at least 2 hr to allow the soil particles to settle. While the outlet is closed, there will still be some flow from the wash areas from clean-up of the bath bottom and wash stations. If the bath dump occurs when there will be no further vehicle washing that day, the outlet valves may remain closed until the following morning to allow further settling. Reopen the outlet valve(s) before the next wash exercise begins. NOTE: This option should not be used if at any time water overflows the basin walls. Read the paragraphs below describing how to estimate the freeboard depth required for this option. It is unlikely that the freeboard of one basin will hold a bath dump, so both basins would have to be taken out of service. If washing is going to continue following the bath dump, use option 2 below.

Option 2: Partially drain down the sedimentation basin(s) before the bath dump. If vehicle washing is finished for the day, then both basins can be drained down to receive the bath dump water. If vehicle washing is not complete for the day, then one basin would be drained down and the other would continue in use. The operator will have to open and close the valves/gates in the splitter box to divert the bath dump to one basin, and then divert the subsequent wash water to the other basin.

It is not necessary to completely drain the basin(s), only to remove the amount of water coming from the bath dump and clean-up. After the bath has been dumped, do not allow water to exit

3 March 2011

the basin(s) receiving the bath water for at least 2 hr. Most basins have outlet pipes and valves specifically for draining down the basin, normally located in the effluent structure. A few facilities do not have drain-down piping and will not be able to use this option.

(7) Basin depth calculation: Which option to use for a specific CVWF depends on the size of the bath (number of lanes) and the volumes of the sedimentation basins. To choose the appropriate option at a CVWF, calculate the depth that a bath dump will displace in the sedimentation basin(s). That displacement depth is the volume of the bath dump divided by the area of the basin. A bath lane at a 3-ft depth holds 7,500-8,000 cubic feet (ft^3) of water. Thus a three-lane bath could hold up to 24,000 ft^3 of water.

Depth of bath dump = volume in bath \div area of sed. basin

For example, suppose the dimensions of one sedimentation basin are 200 x 30 ft. The area of the basin would be 6000 sq. ft. (The actual dimensions are unique to each facility and must be measured by the operator.) A three-lane bath dump would then displace: $24,000 \text{ ft}^3 / 6000 \text{ ft}^2 = 4 \text{ ft}$ of depth in one basin, or 2 ft of depth in both basins. Most sedimentation basins were constructed with 1-3 ft of freeboard. So, in this example, the operator would either drain one basin down so that the water level is over 4 ft below the top of the basin, or drain the bath dump into both basins while making sure the water level is at least 2 ft below the top of each basin.

3.2.2 Equalization basin

The equalization basin is designed to equalize flow to the sand filters. Wash water is stored in the equalization basin during peak usage of the wash areas, and that water is filtered later, when the wash areas are not in use. This capability allows the CVWF designer to minimize the size of the sand filters.

The equalization basin receives the outlet flow (effluent) from the sedimentation basins. The wash water being recycled is stored in the equalization basin until it is sent to the sand filters. At some CVWFs, water from the equalization basin may be pumped to fill the bath prewash and to the trench flushers.

The equalization basin should not be full at the beginning of a wash exercise; it has been designed so that the only time it is full is at the end of a long period of washing. For example, 2-3

3 March 2011

days of almost continuous washing would fill the basin, even though the filters remain in use during that period.

The equalization basin is at its lowest level after long periods without washing activity. After 2 weeks of little or no washing, the equalization basin should have only 2-4 ft of water in it, because the wash water will have been filtered and stored in the clean water basin. When the basin is at its lowest depth, a depth sensor will turn off power to the filter dosing pumps. If the bath(s) are not filled from the equalization basin, then the lowest depth will be 2 ft. If the bath(s) and flushers receive water from the equalization basin, then the shallowest depth from which water will be pumped to the sand filters is 2 ft plus the volume of all bath lanes. In other words, the equalization basin always stores enough water to fill all of the baths when the baths are empty. The low-water sensor for the bath fill pumps would be set at a 2-ft depth.

The facility was designed assuming that filter dosing would continue over a longer period of time than when the wash area is actually being used. The equalization basin is usually sized to equalize flow from 7-14 days of average washing plus one or two large (brigade-sized) wash events, after which the equalization basin will be full. However, the designed filter dosing sequence will lower that level considerably over the several days following the last wash event.

It is important for the operator to understand that the sand filters are not designed to receive the peak flow coming from the wash areas. (This process is explained further in section 3.2.3 Intermittent sand filters.)

Some suspended solids will overflow the sedimentation basins and settle in the equalization basin. Because of this, the bottom 2 ft of the basin is designed for sediment storage. That is why the outlet-to-filter dosing and the fill/flush pump depths are at least 2 ft above the bottom of the basin.

After heavy rain storms, both equalization and clean water basins can become full at the same time. If that happens, partially treated water could overflow the equalization basin entering the environment. This should be avoided if at all possible, since it would violate State and Federal wastewater discharge regulations. The prevention of overflows is discussed in section 3.2.6 Water supply basin. Normally the operator is not actively involved in the operation of the basin, other than to monitor the volume of water in the basin.

3.2.3 Intermittent sand filters

At most CVWFs, intermittent sand filters are used for secondary treatment¹. These filters remove most of the remaining suspended matter and some dissolved material from wash water. At most CVWFs, wash water is pumped from the equalization basin to the surface of the filters. At a few installations, wash water will flow by gravity from a dosing basin to the filters. (The dosing basin is discussed in section 3.2.4 Dosing basin.) The wash water is distributed across the surface of the filters by perforated pipes laid on or suspended over the surface of the sand. Figure A-23 and Figure A-24 show examples of surface distribution piping layouts. Figure A-25 shows one method of applying water to the surface of a filter. A CVWF may have one, two, or three sand filters, and/or a large filter may be subdivided into two or more sections or cells, each of which is dosed separately.

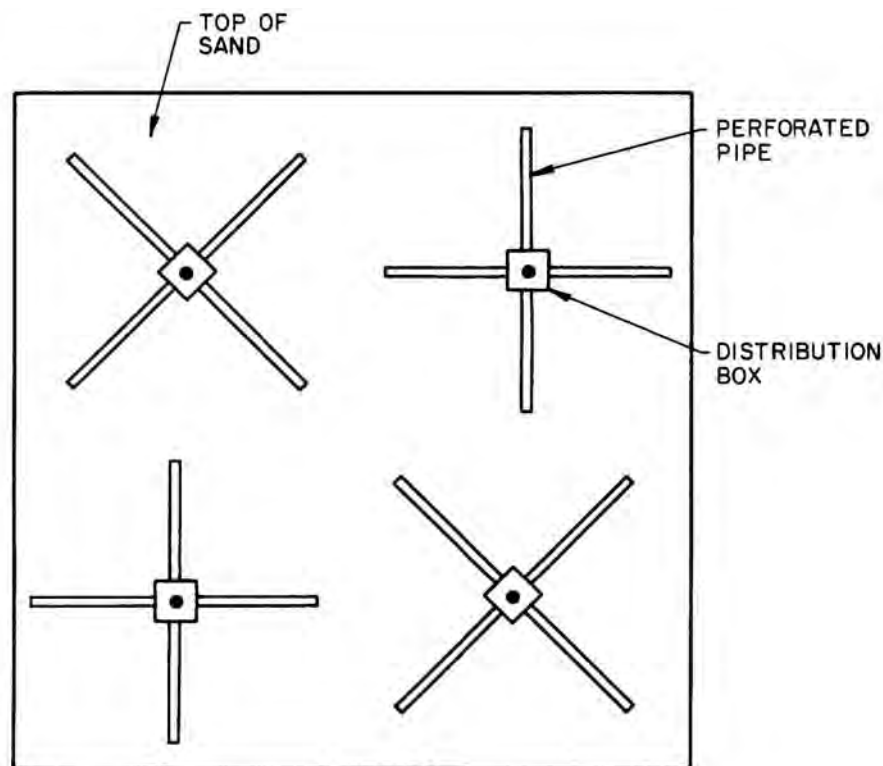

Figure A-23. Example of piping layout on filter surface
(UFC 4-214-03, 2004).

¹ Secondary treatment is a process that follows primary treatment. In the case of CVWFs, primary treatment is always sedimentation basins, and secondary treatment is normally intermittent sand filters or lagoons.

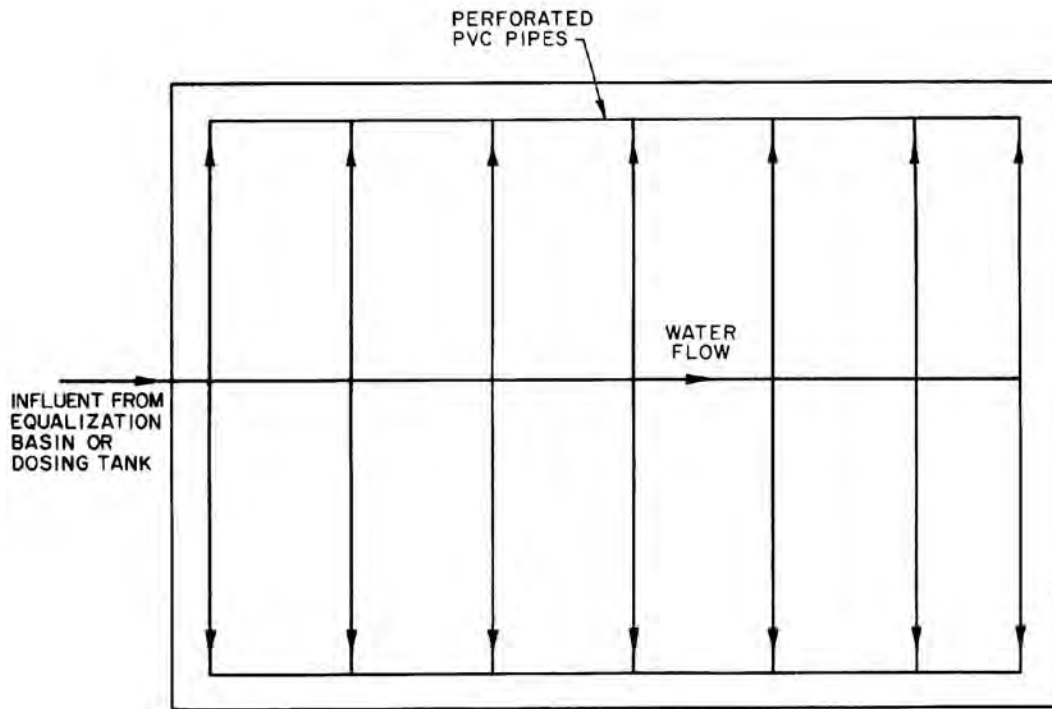

Figure A-24. Another example of piping layout on filter surface (UFC 4-214-03, 2004).



Figure A-25. Sand filter being dosed (photo by ERDC-CERL).

A specific volume of water, called a dose, is applied to the filter surface. That volume was determined during the design of the facility and is based on the amount of small, clay soil particles that are expected to be deposited on the filter surface. A dose is pumped onto the filter surface and allowed to slowly percolate through the filter. A dose should percolate completely through the filter surface before the next dose is applied. This sequence allows the filter to "breathe," i.e., allows air to enter the filter to support aerobic biological degradation of the dissolved organic material in the wash water.

Water that has percolated through the sand and gravel layers of the filter is collected in an underdrain system, which is a lattice of perforated pipes at the bottom of the filter (Figure A-26). If a filter is divided into cells, each cell will have its own distribution piping, but usually one underdrain system will serve the entire filter. Filtered water either flows by gravity or is pumped to the clean water basin. Figure A-27 shows a typical underdrain system layout.

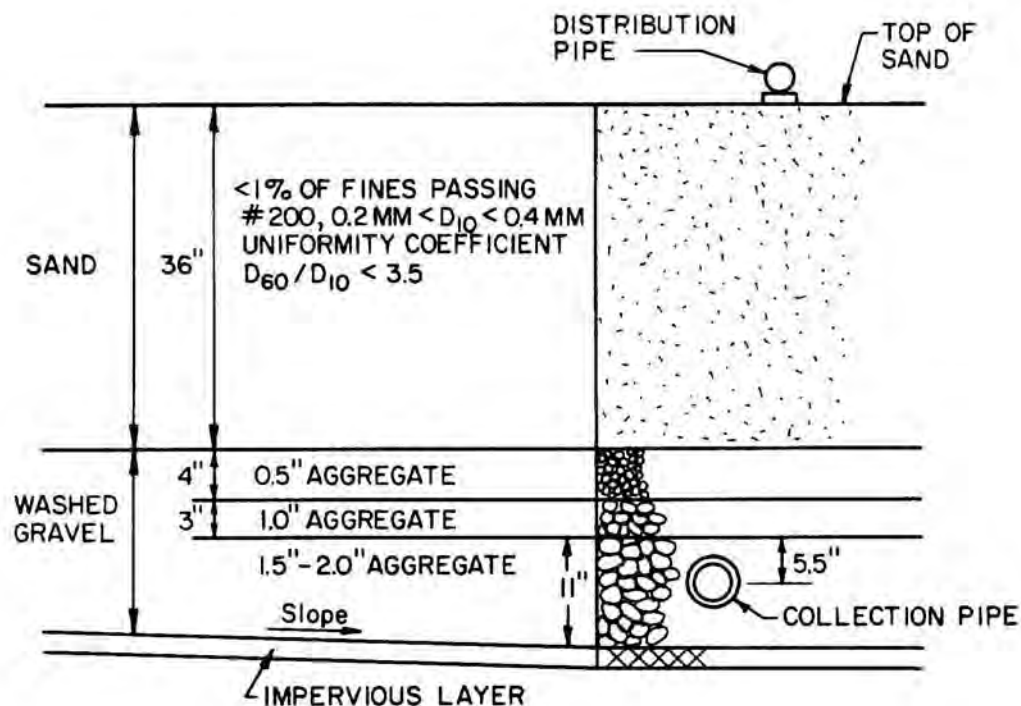

Figure A-26. Cross section of an intermittent sand filter (UFC 4-214-03, 2004).

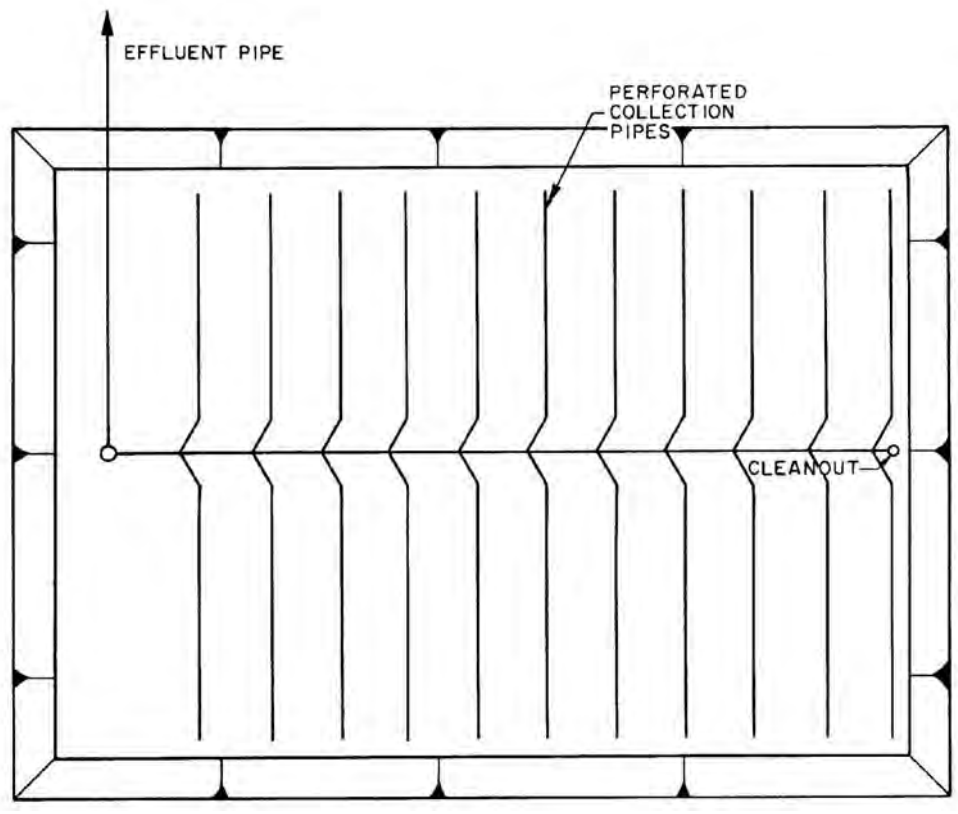

Figure A-27. Example of a filter underdrain layout (UFC 4-214-03, 2004).

Each of the filters or filter cells is dosed three times per day as long as there is water available in the equalization basin. An automatic dosing control system (including timers to sequence the dosing) controls operation of the valves and pumps involved. Pumping time is pre-set so that each dose applied is the correct amount (6-12 in.) of wash water. The amount corresponds to the filter design. Pumping a single dose onto a filter may take 10 min-1 hr, depending on the pump capacity and the number of filter sub-areas to be dosed.

3.2.4 Dosing basin

At a few locations, the CVWF site had enough natural slope for wash water to flow by gravity from the equalization basin to the sand filters without pumping. At these locations, dosing basins are used as a means to accurately measure each filter dose (i.e., the dosing basin is constructed to hold enough water for one filter dose).

3 March 2011

The dosing basin is filled from a pipe coming directly from the equalization basin. Level switches in the dosing and equalization basins control the valves that allow the water to transfer. A combination of timers and level switches open valves on the dosing basin outlet pipe to apply the dose of wash water to a filter or filter cell. Flow from the dosing basin to the filter is usually by gravity, but may be pumped.

3.2.5 Lagoons

Lagoon treatment is an alternative to intermittent sand filters. Water from the primary sedimentation basins flows to a lagoon(s) where the water is retained for 7-14 days. During that period, the small clay-sized particles settle to the bottom and the suspended or dissolved organic material is consumed by biological degradation. Normally a site will have one large lagoon, but there may be two or three lagoons in series.

Lagoons are very simple, as there are no pumps or valves involved in their operation. Water flows into the lagoon through an inlet pipe, travels the length of the lagoon, then exits through an outlet structure. The outlet structure is normally a single pipe that is protected by an underflow baffle to prevent floating oil and debris from exiting the lagoon. Flow through the lagoons is by gravity. Water from the outlet structure normally flows by gravity to the clean water storage basin.

Lagoons are considerably simpler and less expensive to construct and operate. However, they are not the preferred means for secondary treatment of CVWF wash water. Intermittent sand filters provide better quality water for recycle to the wash areas.

3.2.6 Water supply basin

The water supply basin stores the recycled wash water after primary and secondary treatment. Water is pumped from this basin to the wash areas. Water is continually lost from the recycle system due to evaporation and other water losses in the wash areas. Water is also added to the system by rain and other precipitation. The operator should monitor the water level in the water supply basin and make the adjustments necessary to ensure the correct amount of water is available in the system for washing.

The operator should always be watchful of too little water in the treatment system. Approximately 5% of the water used in the

3 March 2011

wash areas is lost to overspray, carry-off, and evaporation. These losses are compounded during extended periods of dry weather when precipitation does not replace water losses. If the clean water basin is not full after an extended period of no washing, then makeup water should be added to the basin. Makeup water normally comes from the potable water system. If the basin level is very low, makeup water should be added at night so that the continuous and heavy flow does not interfere with other flows in the potable water system.

If the equalization basin is at its lowest level and the water supply basin is not full, then the operator should add makeup water to the system. Makeup water is normally added at the wash water pumping structure. If makeup water comes from the installation's water system, then it is best to add the makeup water during off-peak periods. The operator should consult with the installation's DPW to determine the best time to add makeup water.

If there is an accumulation of storm water, both equalization and clean water basins can become full at the same time. If that happens, partially treated water may overflow the equalization basin and enter the environment. This should be avoided if at all possible, since it would violate State and Federal wastewater discharge regulations. Overflows of untreated water can be prevented by planned discharges of the excess water from the clean water basin. These discharges must be approved and monitored by the DPW environmental organization, which normally would have to receive permission for the discharge from local or State authorities. The operator should monitor weather forecasts and notify DPW as far in advance as possible of any likely need to discharge. With experience, the operator will learn to manage the amount of water in the recycle system according to typical seasonal weather patterns. Discharge of excess water is also discussed in section 4.2.6 Water supply basin.

An earthen basin is full when the elevation of the water is 3 ft lower than the elevation of the top of the embankment (3 ft of freeboard). A concrete basin is full when freeboard is about 2 ft.

3.3 Wildlife

The operator should be aware of wildlife issues that may affect CVWF O&M. Basins are attractive to animals such as deer and coyotes that are seeking water. At least one installation has provided a mechanism for these animals to escape the basins

3 March 2011

(Figure A-28). Aquatic animals may mistake the basins for their natural habitat (Figure A-29). Many installations have had snakes nest in wash water piping structures or below-grade valve boxes. The operator should involve the installation environmental office when resolving issues regarding wildlife.



Figure A-28. Chain link can be used as a ladder for animals to escape basins (photo by ERDC-CERL).



Figure A-29. An alligator resides in a CVWF lagoon (photo by ERDC-CERL).

3.4 Operating Log

The operator should maintain a permanent operating log for the CVWF. This daily log should contain entries for: the specific units that have used the facility; the number of vehicles for each unit; the amount of water that was recycled (if meters have been installed); and the amount of makeup water that was added to the recycle system. The log should also be used to record unusual events. For example, the operator should record accidents that occur or wash structure components that are damaged. Table A-1 shows an example of a daily log sheet.

Table A-1. Example log sheet for daily operations.

CAMP SWAMPY CVWF OPERATOR LOG					DATE:	1-Sep-11
UNIT	IN	OUT	TRACKED	WHEELED	COMMENTS	
1/4th INF	830	930	5	10		
2/5th CAV	1200	1330	5	15		
4/22nd TRANS	1400	1700	0	10	Tanker fuel leak at wash island	
NOTES						
WATER USED:	27	x1000 CU. FT.				
MAKE-UP ADDED:	0	x1000 CU. FT.				
Called in fuel leak to environmental. Soaked up what we could at the wash island. Environmental put floating pads in the sed basins. Closed us down for 2 hours.						

4. FACILITY MAINTENANCE

All components of the CVWF require maintenance for operation to continue as designed. Following are descriptions of the regularly scheduled maintenance and inspection that should be performed by the CVWF operator or the installation DPW. The frequency of the maintenance activities described in the following paragraphs will vary from daily to annual.

4.1 Wash Area

4.1.1 Bath prewash

The operator must pay attention to several elements (listed below) of the bath prewash in order to maintain its use.

(1) Valves and valve motors: The operator should monitor the operation of the valves and motors that control the water to the water cannons, wash down hoses, fill and flush pipes, and that control the bath drain. The operator should make a request to the DPW maintenance division for repair or replacement when any of these valves and valve motors shows signs of becoming non-functional.

The operator, or DPW, should perform any regular maintenance to the valves and valve motors as recommended in the manufacturer's manuals. These manuals would have been provided when the CVWF was originally turned over to the installation. If these manuals have been lost, the operator should contact the manufacturer to obtain replacements. Many equipment manuals are available on the Internet from manufacturers' websites.

During periods of non-use, it is normal procedure to exercise (operate) valves and valve motors to maintain internal lubrication of moving parts. Unless manuals direct otherwise, exercise valves and valve motors at least once per week.

(2) Water cannons: The nozzles, seals, and piping that make up the water cannon are subject to wear. The operator should inspect the water cannon weekly to check for leakage and nozzle wear. Nozzles, seals, and piping should be replaced as necessary. The valves on the water cannon should be maintained and exercised the same as the other valves controlling the operation of the bath.

(3) Cold weather: Valves, pipes, and even nozzles can be damaged by water freezing inside them. Valves should be opened and piping should be drained at the end of every wash exercise

3 March 2011

during cold weather months. It may be necessary to open the control valve that feeds water to the water cannon.

(4) Bath drain valve: The operator should inspect this valve after every bath dump. The operator should remove any debris that may have been caught by the valve and would interfere with the operation of the valve. For safety reasons, power to the valve motor must be turned off while removing the debris.

(5) Trench drains: The operator should inspect the trench drains after every bath dump and remove any vegetation or other debris that may have become lodged in the channels.

(6) Bath clean up: Clean up of the bath and staging area is part of the operation and is discussed in Section 3 on OPERATION.

4.1.2 Wash stations

The operator must pay attention to several elements (listed below) of the wash stations in order to maintain their use.

(1) Wash hoses and nozzles: Wash hoses and nozzles tend to wear out because they are damaged by abrasion when dragged across the concrete pavement and by general use and abuse. The operator should keep a few new hoses and nozzles in stock to use as replacements as needed. Installation of a new hose on the wash tower may require a DPW work order.

(2) Valves: Leaking valves on the hose towers should be repaired or replaced by DPW work order. Valves should be exercised at least once per week.

(3) Cold weather: Valves, pipes, and hoses are often damaged by water freezing inside them. Valves should be opened and piping and hoses should be drained at the end of every vehicle wash operation during cold weather months. It may be necessary to open the control valve that feeds water to the wash stations.

(4) Trench drain: The operator should inspect the trench drains after every vehicle wash operation and remove any vegetation or other debris that may have become lodged in the channels.

(5) Trench drain grates: The operator should replace, or have repaired, the grates covering the trench drains that have become damaged.

(6) Lighting: The operator should replace burnt out or broken light bulbs in the low-level lighting. Replacing bulbs in the

overhead lights on hose towers and light poles will require a DPW work order.

4.2 Wash Water Treatment System

4.2.1 Primary sedimentation basins

The operator has a few routine tasks to perform at the sedimentation basins. These tasks are normally done while the wash areas are not in use.

(1) Remove floating debris: Vegetation and trash are carried to the sedimentation basins with the wash water and trapped by the netting and underflow baffles at the effluent end of the basins. The operator should use long-handled nets and rakes to periodically remove this debris. If left in the basin, debris can become water-logged and sink to the sediment at the bottom of the basin, which is not desirable. Environmental regulations require that the sediment be disposed in a landfill if it contains water-logged trash. To prevent this from happening, the operator should remove the debris at least once per week. The debris that is removed should be placed in a refuse dumpster. Items such as batteries, bottles of chemicals, etc. should be disposed according to guidance from the installation DPW environmental group.

(2) Remove debris in the inlet structure: Rocks and large pieces of vegetation tend to accumulate on the influent distribution trough (if one exists; see Figure A-19). The operator should remove these items periodically (as needed) in order to maintain good distribution of the influent flow across the width of the basin.

(3) Maintain the oil skimmer: The oil skimmer normally has a floating tube that moves in a loop from the water surface to the oil-removing device and back to the water surface (see Figure A-22). The device that removes the oil from the tube tends to collect grass clippings and other floating vegetation in its works. The operator should periodically (as needed) clean this debris out of the oil skimmer mechanism to allow proper operation. The debris should be placed in a garbage bag and disposed in a dumpster. Figure A-30 shows an oil skimmer at Fort Lewis clogged with pine needles.



Figure A-30. Oil skimmer clogged with pine needles
(photo by ERDC-CERL).

When cleaning the skimmer, the operator should also check the motor, internal machinery, and the condition of the floating tube to make sure all are functioning properly. This should be done periodically even if the skimmer has been intentionally taken out of service.

(4) Service the oil storage tank: Floating oil and water picked up by the floating skimmer tube is deposited in a storage tank. The operator should check the liquid level in the tank periodically (once a month, or as often as is needed at the site) when the skimmer is operating. The majority of the liquid put into the tank is water. If the tank has a bottom drain valve that will empty liquid back into the sedimentation basin, the operator should use this valve to prevent the tank from filling with water. Whenever the tank is nearly full, the operator should open the valve and drain the water from the tank until oil begins to flow out and then immediately close the drain valve. When the tank is over half full of oil, the operator should contact the DPW environmental group to have it emptied. If there is no drain valve, the operator should contact the DPW environmental group whenever the tank is almost full.

(5) Prepare to clean out the sedimentation basins: Cleaning out the sedimentation basins is the most significant CVWF maintenance operation. A large volume of sediment, up to 500 cu yd, accumulates in the bottom of each basin between cleanouts. Removing and disposing of this much material consumes a great deal of labor and equipment hours. The following steps are to be taken prior to the actual cleanout:

3 March 2011

(5a) Determine when to clean out the basin: Cleanouts are done on an as-needed basis, rather than on a schedule. Generally sediment basins have been designed so that the bottom 2 ft of basin depth is dedicated to sediment storage. However, experience has shown that it is difficult to manage that much sediment during a cleanout operation. It is recommended that the basin be cleaned out when an average of 1 ft of sediment has accumulated.

The sediment does not accumulate in an even layer. There will be a mound of rocks, sand, and clods of dirt at the influent end because those materials sink very quickly (Figure A-31). This mound may extend over one-fourth to one-third of the basin. The remaining sediment forms a more even layer by stretching from the mound to the outlet end of the basin. This even layer will be shallowest at the outlet end.

Because of the uneven distribution of sediment, it is difficult to measure exactly when the average depth is 1 ft. One general rule is to clean out the basin when the top of the mound breaks the surface of the water. Another general rule is to clean out the basin when the depth of the sediment at about the midpoint of the basin (measured at the side) is about 6 in. Eventually the operator's experience will dictate when to clean out the basin. The sediment should never be allowed to fill more than one-fourth of the basin.



Figure A-31. Drained sedimentation basin prior to a cleanout (photo by ERDC-CERL).

How quickly sediment accumulates depends on how muddy the maneuver areas are and how many vehicles are washed. Cleanouts may be needed only once a year if the weather is dry and the units have been deployed. Cleanouts may be needed two or three times per year if the weather is wet and training is frequent.

A primary consideration is whether there is a drying pad and how much sediment it will hold. At a few CVWFs, a concrete pad has been placed near the sedimentation basins for drying the sediment (Figure A-32). During a cleanout, the sediment is moved from the basin and spread in an even layer on the drying pad. The sediment is left there for an extended period of time to allow the water in the sediment to evaporate. It is recommended



Figure A-32. Sediment drying area adjacent to sedimentation basins at the Yakima CVWF (photo by ERDC-CERL).

3 March 2011

the sediment be no more than 4-in. deep on the drying pad. Generally a drying pad will be too small to accept sediment from both basins. The size of the drying pad will determine when a basin will need to be cleaned out if it can hold less sediment than the maximum amount that could be allowed to accumulate in the sedimentation basins.

(5b) Determine the amount of sediment that can be placed on the drying pad. To do this, simply measure the area of the pad where sediment will be spread. This area (in square feet) times the depth in feet (1/3 ft recommended) is the volume of sediment (in cubic feet) that can be spread on the drying pad. The volume that can be put on the drying pad, divided by the area of the sedimentation basin, is the average depth of sediment that can be allowed to accumulate in the basins between cleanouts. Following is an example of these calculations.

EXAMPLE: The usable area of the drying pad at the Camp Swampy CVWF is 100 x 150 ft. (This area does not include entrance ramps or other areas where sediment will not be dumped.) The area for sediment to be spread is:

$$100 \text{ ft} \times 150 \text{ ft} = 15,000 \text{ sq ft.}$$

The amount of sediment that can be dumped onto the drying pad is:

$$15,000 \text{ sq ft} \times 1/3 \text{ ft} = 5,000 \text{ cu ft.}$$

The sedimentation basin at the Camp Swampy CVWF is 225-ft long by 30-ft wide. The area of the sedimentation basin is:

$$225 \text{ ft} \times 30 \text{ ft} = 6,750 \text{ sq ft.}$$

When 5,000 cu ft of sediment accumulates in the basin, the average depth of the sediment would be:

$$5,000 \text{ cu ft} \div 6,750 \text{ sq ft} = 0.74 \text{ ft (about 9 in.)}$$

The sedimentation basin at the Camp Swampy CVWF should be cleaned out just before the mound breaks the surface of the water or when the depth of the sediment at the midpoint is about 4.5 in.

At most CVWFs, it is up to the operator to determine when the basin should be cleaned out and to make a request for DPW to do

3 March 2011

the cleanout. The operator should monitor the amount of sediment that has accumulated in the basin by taking a sediment depth measurement at least once a month.

(5c) Make a simple measurement of the basin's sediment depth according to the following guidelines:

- Where to measure: Measurement should be taken about the middle of the basin.

Note: If the basin has a ledge that is the length of the bottom along the side wall(s), measure the depth at a point that will not include this ledge.

- Equipment: The sediment at the midpoint of the basin is usually soft and fluid. It is easiest to find the surface of the sediment by lowering a flat surface. The bottom of a bucket can be used as a low-tech tool. Poke holes in the bottom of the bucket and put a few rocks in it so it will sink slowly after it fills with water. Attach a rope to the bucket handle so the bottom of the bucket remains level when it is lowered through the water to the top of the sediment layer.
- Measure basin depth: Take a long rod and poke it through the sediment layer to the basin bottom. Mark the rod where it enters the water. Pull up the rod and use that mark to measure the basin depth.
- Measure the depth of water above the sediment: Lower the bucket from the side of the basin. When the rope begins to go slack, the bucket is at the top of the grit layer. Mark the rope where it breaks the surface of the water. Pull up the bucket and use that mark to measure the depth of water above the grit layer. Depth of sediment: Subtract the depth of the water above the grit from the total depth to arrive at the depth of the grit.

Example: The length of the rod from the tip to where it broke the surface of the water is 8 ft, 3 in., and the distance from where the rope broke the surface of the water to the bottom of the bucket (when touching the surface of sediment) is 7 ft 6 in, making the depth of the sediment expressed as follows:

$$8 \text{ ft } 3 \text{ in.} - 7 \text{ ft } 6 \text{ in.} = 9 \text{ in.}$$

3 March 2011

(6) Remove the sediment from the sedimentation basins: The steps involved in performing a basin cleanout are as follows:

(6a) Check for floating oil on the surface of the basin. If free oil is floating on the surface, remove it by using the floating tube skimmer, or by using floating oil-absorbing socks or pads. Request assistance from the DPW spill control office if needed.

(6b) Drain water from the basin. Most basins have one or more drain pipes and valves at the outlet end of the basin. Open these valves and allow all of the water to drain from the basin. If the drain pipe is not low enough to drain all of the water, use a portable pump to remove the rest of the water. Water will continue to slowly separate from the sediment. Allow the sediment to "dewater" for a few days while continuing to drain or pump water from the basin. It is important to remove as much of the water as possible in order to make the sediment removal easier.

At some installations, it may be useful to allow the sediment to dry for an extended period (2 or more weeks). This will make removing the sediment easier. Mixing the coarse material in the mound with the rest of the sediment should speed the drying process. Continue to drain water from the basin during drying period, and after the mound material has been mixed in.

Note: The bottoms of some basins have a short sub-wall that forms a long gravel-packed channel along the side wall of the basin. There is a perforated pipe buried under the gravel that traverses the length of the basin. The pipe exits the basin in the corner of the effluent structure. The intended purpose of this structure is to help dewater the sediment. Water in the sediment is supposed to seep through the gravel and flow into the pipe. The operator should open the valve controlling the outlet of the channel drain pipe after the basin has been drained down. The valve should be closed after the basin has been cleaned out and before it is refilled with water.

(6c) Sample the sediment. Before the sediment is removed from the basin, it will probably be necessary to sample and analyze it. This sampling would normally be performed by the post DPW environmental group, or it could be done by the operator under DPW's guidance. Ideally, this sampling would be done before the basin is taken out of service so that treatment of the wash water is not interrupted any longer than is necessary during the whole cleanout process. However, allowing the sediment to dewater while waiting for sample results is also good. If a

3 March 2011

drying area exists, sampling should be done after the sediment has been moved to that area.

Guidance for sampling is contained in the EPA publication SW-846, "Test Methods for Evaluating Solid Wastes, Physical/Chemical Methods", Chapter 9 "Sampling Plan." This document contains guidance for sampling sediment and for sampling from piles or mounds of waste material. Generally, it is required that "representative" samples of the waste be collected. "Representative" is not specifically defined in SW-846, as sampling plans are somewhat site-specific. It is the responsibility of the sampling person or team to ensure that samples are representative.

Note to DPW sampling personnel: There is a slight possibility of "hot spots" of contamination in the sediment, especially POL-contaminated products. Those "hot spots" may skew test results unless material is taken from several locations in the basin or drying pad. To minimize the cost of sampling and analysis, take several aliquots (perhaps 10 or more) to form composite samples. It may be best to sample after the entire sediment layer has been mixed by a front-loader.

(6d) Remove the sediment. Removing the sediment is messy and time consuming, and no combination of earthmoving equipment has been found that is perfect for the job. At many installations, a front-loader has worked best for removing the sediment from the basins, though other pieces of equipment also are being used. (See Figure A-33 and Figure A-34.)



Figure A-33. Front-loader and clamshell crane used to clean out basin (photo by ERDC-CERL).



Figure A-34. Telescoping bucket used to remove sediment (photo by ERDC-CERL).

3 March 2011

Before removing the sediment, use the front-loader to move the material in the mound and distribute it evenly throughout the basin. Use the front-loader to mix the mound material into the more liquefied material that settled in the rest of the basin. Mixing the coarse sediment with the soupy sediment will help it to dry faster. The front-loader is then used to load the sediment into dump trucks or to carry the sediment directly to an adjacent drying pad (if available).

CAUTION: The ramp into the basin will become slick and hazardous due to sediment spillage. Truck, front-loader, and other wheeled-vehicle drivers must be careful not to lose traction when driving up and down a ramp.

(6e) Dispose the sediment. What happens to the sediment after it is removed from the basin is determined by the installation DPW environmental group. The protocol at each installation will be unique, because of variations in State laws regulating the disposal sediment. Generally the results from the sampling will influence the decision on where the sediment will be delivered. Most installations now have bioremediation sites where the sediment is processed. At other sites the sediment may be allowed to dry at the drying pad or in the basin until it can be used for fill material or for landfill cover.

4.2.2 Equalization basin

(1) Monitor the condition of the basin: The equalization requires no periodic maintenance. However, the operator must monitor the condition of the basin in order to prepare service orders that may be necessary to make repairs. The operator should perform at least monthly inspections. Specifically, the operator should look for:

(1a) Excess water in the equalization basin: If this occurs, the operator should determine whether it is caused by a large inflow from precipitation that has overflowed the system, or by a failure of the filter dosing pumps or the dosing control system. Removal of excess water in the recycle treatment system is discussed in section 4.2.6 Water supply basin.

(1b) Damage to the equalization basin liner: Many basins are lined with a rubber-like membrane that will deteriorate over the years. Adhesives and sealers holding sections of the membrane together, or holding the membrane to inlet and outlet structures, can also deteriorate. Inspect the liner when the water level is at its lowest. Figure A-35 shows the low water

3 March 2011

level in an equalization basin; the intake structure in the bottom of the basin is visible.

(1c) Basin is losing water: If the water level in the basin continues to go down when no water has been pumped from the basin, then water is leaking through the liner. Leakage will be most noticeable after a long period with no washing when the basin is at its lowest level. If the basin liner is damaged and/or the basin is leaking, the operator should notify DPW and the environmental office.

(2) Equalization basin cleanout. The equalization basin will eventually require a cleanout. The sedimentation basins are not 100% efficient, and some solids will settle in the basin during the long periods of water storage following large washing operations. The basin is designed to have 1 ft of sediment storage capacity in the bottom. Pump intakes are designed to draw water from above this sediment storage (see bottom intake structure in Figure A-35). There is not enough usage data to predict when a cleanout will be needed. But it was originally thought that a CVWF could go 15-20 yr without needing an equalization basin cleanout.



Figure A-35. Nearly empty equalization basin – outlet box and outlet valve wheel are shown (photo by ERDC-CERL).

The operator should monitor the basin to determine when a cleanout may be needed. Cleanout indicators are: (a) the sediment level is visible at or near the surface of the water when the basin has been pumped down to the lowest water level; or (b) an increased amount of solids is being pumped onto the surface of the filters because sediment is entering the wet well for the dosing pumps.

When the equalization basin needs to be cleaned out, the operator should submit a work order to DPW. The actual cleanout will probably be done by contract. Cleaning out the basin will be a long and expensive effort because the membrane liner may have to be destroyed and replaced in the process. The CVWF may have to be taken off line for several months. A cleanout of the equalization basin should be scheduled at a time when it will have the least impact on vehicle washing. Because sediment accumulates so slowly, the operator should have plenty of time to notify DPW in advance that a cleanout is needed.

The characteristics of the sediment will be very similar to the sediment that accumulates near the outlet end of the

3 March 2011

sedimentation basin. The particle size of the soil particles will be very small (nearly all will be clay particles, i.e., will pass a 200-mesh screen). It is unlikely the sediment will be a characteristic hazardous waste, though there may be detectable quantities of petroleum hydrocarbons. It is unlikely the sediment being removed will pass a paint filter test, which means that the sediment will need to be dewatered before final disposal.

The statement of work for a basin cleanout should include the following considerations to be addressed in the general provisions and tasks:

- Work schedule. The contractor should provide a specific work schedule. Because washing, and possibly training, will be affected by the CVWF being down, the DPW should consider including rewards for early completion and penalties for late completion.
- Removing the sediment. Several types of equipment and methods might be used to remove the sediment. In order to increase competition, the contractor should be allowed to determine the method for removing the sediment. Technologies are available to remove the sediment without damaging the liner. However, if the liner needs to be replaced, or if it is not cost effective to try to save it, the contractor could choose to remove the sediment by a method that would destroy the liner during the process.
- Disposing the sediment. The sediment will need to be dewatered prior to disposal, i.e., it must meet the free water requirement in SW-846 (pass the Paint Filter Test). The DPW may already have dewatering/drying capability and provide that capability to the contractor. The sediment will need to be analyzed for hazardous characteristics and total petroleum hydrocarbons prior to disposal. The DPW may already have this capability and may provide it to the contractor. If the sediment is to be disposed off post, an intermediate storage site will need to be established for the sediment, probably at the CVWF site. The DPW may also have this capability and may provide it to the contractor.
- Repairing/replacing the liner. It may not be known whether the liner needs to be replaced until the basin has been emptied. The bidders should be required to provide bids with and without replacement of the liner. If the liner is

3 March 2011

to be left in place, the contractor should be required to repair all leaks, both existing and those caused by sediment removal equipment. The basin should be tested for leaks following the repair or replacement as a means to certify completion of the contractor's task. Note: The DPW likely will want to use a cleanout contract as an opportunity to replace the aging liner, whether it is leaking or not.

4.2.3 Intermittent sand filters

The intermittent sand filters are the most complex, maintenance intensive, complained about, abused, misused, and misunderstood treatment process in the recycling system, but, they are the key to maintaining good water quality. Compared to other treatment processes that would achieve the same water quality, the intermittent sand filters are by far the simplest process to operate and maintain.

It is important for the operator to understand the correct operation of the intermittent sand filters. Operation is explained in section 3.2.3 Intermittent sand filters. The operator has few specific tasks regarding the maintenance of the sand filters. One important task is to monitor the automatic dosing system to ensure that it is operating correctly.

The other tasks the operator must perform involve servicing the surface of the filters. A layer of slimy sediment will collect on the filter surface over time. The slimy layer will eventually become tightly matted, block flow through the filter surface, and cause ponding. Ponding is when water percolates so slowly through the filter surface it will remain on the surface for several hours. At installations that have clayey soils and/or chronically wet training areas, this layer can form quickly. At those installations the filter surface will require frequent attention. Figure A-36 shows ponding on an intermittent sand filter.

When a slimy mat begins to form on the surface, the operator should take the filter or filter section out of service for a day or so (preferably during a slow period of washing and during sunny weather) so the filter surface will dewater. Allow the surface mat to dry enough so that it can be raked off the filter surface. Normally this mat removal is done manually, but light equipment (such as a Bobcat) can be used. The material raked off should be stored on the sedimentation basin drying pad or taken

to a site designated by the DPW environmental group. Figure A-37 shows dried matted material on the surface of a filter.



Figure A-36. Ponding on an intermittent sand filter (photo by ERDC-CERL).



Figure A-37. Surface of sand filter that needs to be scraped (photo by ERDC-CERL).

The frequency at which the filter needs to be scraped will depend on soil conditions and facility usage. At installations with clayey soils and heavy demand for washing of vehicles, the filters may need to be scraped at least once a month.

The operator should also remove all deep rooted vegetation. These plants can extend their roots to the underdrain system. Generally broadleaf weeds and other broadleaf plants cause the problems. The growth of short-leaved grass is generally not a problem. In fact, at some locations, a growth of short-leaved grass on the filter surface can enhance the performance of the filter and reduce the required maintenance. Grass on the filter provides additional filtration capability and also provides a path for the water to penetrate the layer of fine soil particles deposited on the filter surface. Grass may extend the operating period between scrapings.

The operator should avoid the following practices that can contribute to poor filter performance and increased maintenance.

(1) Manually dosing the filters. It is important that only the correct volume of water is applied to a filter. The automatic dosing system should have been designed to do this. Putting too

3 March 2011

much water on the filter at one time will cause too much hydraulic pressure on the top of the filter, which in turn causes the suspended soil particles to penetrate too deeply into the filter. This also causes the filter surface to plug.

(2) Changing the dosing settings. Because the flow to the filters is less than the flow from the wash areas, it is tempting to increase the length of time the filter pumps operate. Filter pump controls should remain as originally set.

NOTE: It is possible the original settings were incorrect. If the filter system does not maintain an adequate amount of water in the water supply basin, or if the pumps are dosing too much water onto the filters, then the settings should be adjusted. If either is the case, refer to the original Design Analysis to determine the appropriate dosing rates. The operator should submit a work order to DPW to adjust settings.

(3) Allowing ponding. Ponding is when water remains on the surface of a filter after an 8-hr dosing cycle. It is important to scrape or rake the surface of the filter as soon as ponding begins to occur.

Raking and scraping the sediment and muck from the surface of the filter will help extend the length of time a filter is in service. Eventually, however, soil particles will migrate beneath the surface of the filter, and the top layer of sand will have to be removed. Figure A-38 shows filtered solids having penetrated into the top few inches of filter sand. When flow through a filter does not significantly improve after scraping the surface, the operator should submit a service order to DPW to remove the top layer of sand. Often removing the top 3-6 in. of sand will restore normal percolation through the filter. This removal can be done 3 or 4 times before sand should be replaced. The original layer of sand is 36-in. deep. The sand layer should not be allowed to become less than 24-in. deep.

Figure A-39 shows the correct layering of sand and gravel in an intermittent sand filter. Note that the specification for the sand is included in this figure. This specification should be used when DPW purchases replacement sand.



Figure A-38. Surface of a sand filter with 2-3 in. of hard crust (photo by ERDC-CERL).

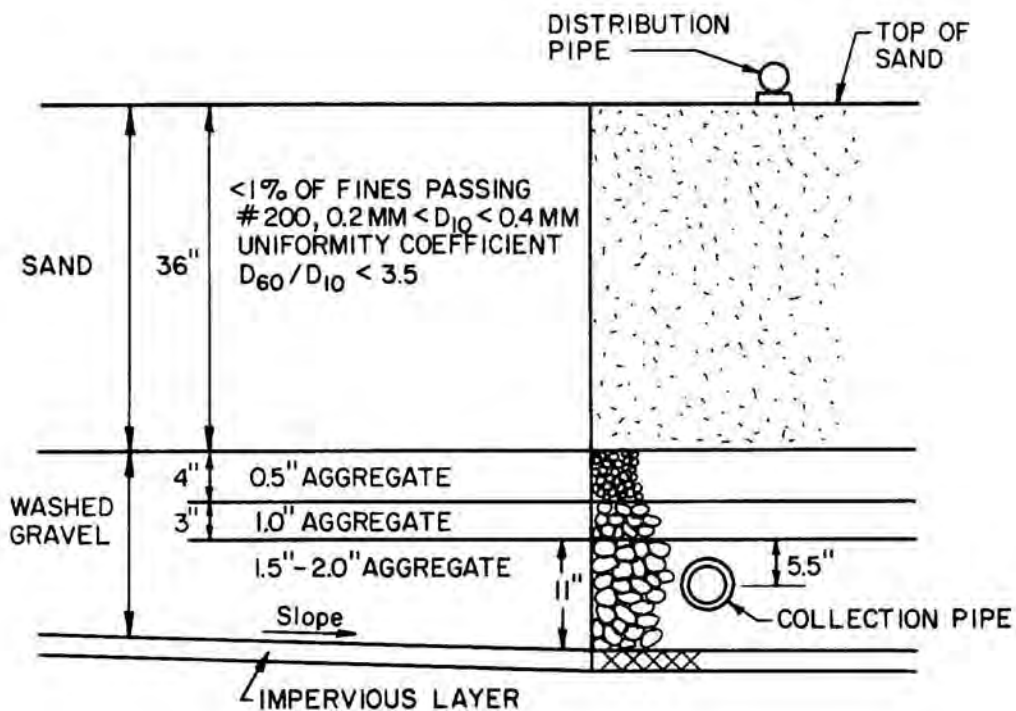

Figure A-39. Intermittent sand filter cross section and sand specification (UFC 4-214-03, 2004).

4.2.4 Dosing basin.

The dosing basin should require little or no maintenance. It is possible there will be some accumulation of sediment in the basin, though water will generally not be retained long enough for any significant accumulation. The operator should occasionally check the condition of the structure.

4.2.5 Lagoons

Lagoons are an alternative secondary treatment. A CVWF will have either lagoons or intermittent sand filters – never both. Lagoons are earthen basins constructed very similarly to the equalization basin. For that reason, the maintenance of lagoons is identical to the equalization basin in most aspects.

- 4.. Monitor the condition of the lagoon. A lagoon requires no periodic maintenance. However the operator must monitor the condition of the lagoon in order to prepare service orders that may be necessary to make repairs. The operator should perform at least monthly inspections. Specifically, the operator should look for:

(1a) Excess water in the lagoon: The only cause of excess water in a lagoon is a large inflow from precipitation that has overflowed the system. Removal of excess water in the recycle treatment system must be done by DPW. This is discussed in section 4.2.6 Water supply basin.

(1b) Damage to the lagoon liner: Most lagoons are lined with a rubber-like membrane that will deteriorate over the years. Adhesives and sealers holding sections of the membrane together, or holding the membrane to inlet and outlet structures, can also deteriorate.

(1c) Lagoon losing water: If the water level in the lagoon continues to go down when no water is flowing from the outlet, then water is leaking through the liner. Leakage will be most noticeable after a long period with no washing when the water level in the lagoon should remain stable (i.e., does not fluctuate due to usage at the wash areas).

(2) Clean out the lagoon. A lagoon will require a cleanout at some time. Suspended solids carry over from the sedimentation basins to the lagoon and settle during the long period of water storage. Biological growth cycles will contribute to the sediment in the lagoon bottom. The lagoon is designed to have at least 1 ft of sediment storage capacity in the bottom. The

3 March 2011

operator should monitor the depth of sediment in the basin to determine when a cleanout may be needed. A good indication that a cleanout is needed is when the quality of the wash water is no longer acceptable for a high contact use such as washing.

When a lagoon needs to be cleaned out, the operator should submit a work order to DPW. The actual cleanout will probably be done by contract. Cleaning out the lagoon will be a long and expensive effort because the membrane liner may have to be destroyed and then replaced in the process. The CVWF may have to be taken out of service for several months. A cleanout of the lagoon should be scheduled at a time when it will have the least impact on vehicle washing. Because sediment accumulates so slowly, the operator should have plenty of time to notify DPW in advance that a cleanout is needed.

The characteristics of the sediment will be somewhat similar to the sediment that accumulates near the outlet end of the sedimentation basin. The particle size of the soil particles will be very small – nearly all will be clay particles (i.e., will pass a 200-mesh screen). The sediment should also have a significant amount of organic material in it. It is unlikely the sediment will be a characteristic hazardous waste, though there may be detectable quantities of petroleum hydrocarbons. It is unlikely the sediment being removed will pass a paint filter test, which means that the sediment will need to be dewatered before final disposal.

The statement of work for a lagoon cleanout should include the following considerations to be addressed in the general provisions and tasks.

- Work schedule: The contractor should provide a specific work schedule. Because washing, and possibly training, will be affected by the CVWF being down, the DPW should consider including rewards for early completion and penalties for late completion.
- Removing sediment: Several types of equipment and methods might be used to remove the sediment. In order to increase competition, the contractor should be allowed to determine the method for removing the sediment. Technologies are available to remove the sediment without damaging the liner. However, if the liner needs to be replaced, or if it is not cost effective to try to save it, the contractor could choose to remove the sediment by a method that would destroy the liner during the process.

3 March 2011

- **Dewatering sediment:** Sediment will need to be dewatered prior to disposal. Because there will be a large quantity of sediment, perhaps thousands of cubic yards, the DPW may not have the capability to handle it. The installation may have to provide a site where a temporary dewatering activity can be set up.
- **Disposing sediment:** Sediment will need to be analyzed for hazardous characteristics and total petroleum hydrocarbons prior to disposal. This should be done by a DPW environmental group prior to writing the contract statement of work. If the sediment does not require special handling and disposal as a hazardous material, the DPW may provide a means to dispose it on post. If disposed as a solid waste, the sediment will have to have been dewatered to the extent that it will pass the Paint Filter Test described in EPA report SW-846.
- **Repairing/replacing the liner:** It may not be known whether the liner needs to be replaced until the basin has been emptied. The bidders should be required to provide bids with and without replacement of the liner. If the liner is to be left in place, the contractor should be required to repair all leaks, both existing and those caused by sediment removal equipment. Note: It is likely that DPW will want to use the cleanout contract as an opportunity to replace the aging liner, whether it is leaking or not.

4.2.6 Water supply basin

The water supply basin structure should require little or no maintenance. The operator should pay attention to condition of the basin liner and submit a work order to make repairs if they should be necessary. The basin should contain little or no accumulation of sediment as long as the treatment system is operated and maintained properly.

The operator should pay attention to the water level in the basin. Low levels of water can be an indicator of maintenance or repair actions that are needed elsewhere at the CVWF, such as the failure of valves or pumps in the treatment system. It is possible that a low water level is a result of leakage through the basin liner.

Normally a low water level in the supply basin means that makeup water is needed. Water is lost every time the wash areas are

3 March 2011

used due to overspray, carry-off, and evaporation. Periodically these losses need to be replaced with makeup water. Makeup water should be added during a low usage period when the equalization basin is at its lowest level. The addition of large amounts of makeup water should be coordinated with DPW because the addition may impact flow in the potable water system.

It is possible that the water supply basin has excess water. That can happen following long and/or intense periods of precipitation. When the potential for water to overflow the basin exists, the operator should report the situation to the DPW environmental group. The DPW will then obtain the permissions and/or permits necessary to discharge the excess water to the environment. DPW will then discharge the excess water until the basin is at the normal maximum operating level (and the equalization basin is at the lowest operating level). Note: It is important that the DPW environmental office periodically test the quality of the water in the water supply basin in order to show the water is of discharge quality. This should expedite obtaining permission for emergency discharges.

4.2.7 Support components (motors, valves, piping)

The operator must continually check the operation of all pumps and valves throughout the CVWF. The operator should make sure that all valves and pumps are exercised at least once per month. The operator must continually be alert for leaking pipes, both above and below ground level. Leaks below ground level are often revealed by water seeping from the soil or soil that is continually wet.

Work orders to repair pumps, valves, and piping should be submitted as soon as possible. If repairs will take the facility out of service, they should be scheduled during a low usage period.

4.2.8 Maintenance log

The operator should keep a permanent log of all maintenance that is performed at the CVWF. Each entry in the log book should include a detailed description of the maintenance and the date(s) it was performed. The entries should record all maintenance and repair work, including daily and periodic maintenance performed by the operator and work performed by DPW personnel or their contractors.

Example of a log book entry:

Date: 1 Sept 2011

Operator: Cleaned sticks out of the bath drain valve. Removed trash from sed. basins; pulled weeds on filters 1 and 2.

DPW: Cleaned mud and debris from the wet well under the filter dosing pumps. While they were here we measured the depth of mud in the sed. basins. It was 4" deep at the half-way point on both.

4.2.9 Water quality

Because water from the recycle system may be discharged to the environment, the quality of the treated water should be at a level where it can be discharged without requiring additional treatment. More importantly, the water should be of such quality that it does not harm the Soldiers using it or cause damage to their vehicles. Some states may regulate recycle systems and have specific water quality requirements for recycle wash systems.

The quality of water in the recycle system should be tested periodically in order to confirm and record the performance of the recycle system. Testing will help determine if the treatment system is being operated correctly or if it needs additional maintenance (or upgrade). Minimally, the treated wash water should be analyzed for suspended solids, dissolved solids, total petroleum hydrocarbons, and coliform bacteria. Other analyses may be required to comply with various State regulations. The DPW environmental group should be responsible for monitoring the recycle system water. It is recommended that samples of the treated water be taken at least monthly.

The amount of suspended solids and petroleum hydrocarbons in the water indicate how well the treatment system is performing, as it is designed specifically to remove these contaminants. Ideally these parameters should be at or below quality requirements for an intermittent or single event discharge (as imposed by State regulations).

The coliform bacteria count will give a general indication of whether the water is safe for use by the Soldiers. Because washing vehicles is a high-contact activity, the coliform bacteria count should comply with State standards that allow

PWTB 200-1-87

3 March 2011

swimming in natural water bodies. Other criteria may also be appropriate.

The amount of suspended solids and dissolved solids in the water indicates whether the water will cause abrasion or corrosion damage to the vehicles. As a general rule, an arbitrary limit of 1,000 parts per million dissolved solids is recommended.

APPENDIX B:

ACRONYMS, ABBREVIATIONS, AND GLOSSARY

AR	Army Regulation
ASCP	Army Sustainability Campaign Plan
BRAC	Base Realignment and Closure
CECW	Directorate of Civil Works, U.S. Army Corps of Engineers
CEMP	Directorate of Military Programs, U.S. Army Corps of Engineers
CERL	Construction Engineering Research Laboratory
CVWF	Central Vehicle Wash Facility
CVWR	Central Vehicle Wash Rack
DA	Department of the Army
DIO	Directorate of Industrial Operations
DoD	Department of Defense
DPW	Directorate of Public Works
EO	Executive Order
ERDC	Engineer Research and Development Center
ETL	Engineer Technical Letter
HQUSACE	Headquarters, U.S. Army Corps of Engineers
NCOIC	Non-Commissioned Officer in Charge
OIC	Officer in Charge
O&M	operation and maintenance
PDF	portable document file
POC	point of contact
PWTB	Public Works Technical Bulletin
TM	technical manual
TVW/TVWR	Tactical Vehicle Wash Rack
TVWF	Tactical Vehicle Wash Facility
UFC	Unified Facilities Criteria
URL	universal resource locator
USACE	United States Army Corps of Engineers
WBDG	Whole Building Design Guide
WWW	World Wide Web

GLOSSARY

Assembly Area - Paved area located after the wash stations to allow repacking of interior items, reassembly of vehicles into units, and final inspection of vehicles prior to leaving the CVWF.

Biological Treatment - Process in which bacteria and other microorganisms use constituents in waste water as a food source, resulting in the breakdown of complex organic materials into more simple substances.

Bypass Lane - Driving lane for vehicles in the CVWF to go past the bath prewash and/or wash stations without interfering with ongoing washing.

Central Vehicle Wash Facility - A system of structures designed for cleaning tactical vehicles.

Cleanout - The process of removing sediment from a bath, sedimentation basin, or equalization basin.

Cleanup Time - Period of time required to clean up the wash areas, including the bath, in preparation for the next group of vehicles to use the CVWF.

Cohesive Soil - Fine-grained, clayey soil that sticks to vehicles and is difficult to remove by washing.

Collection System - A network of below-grade piping and appurtenances that conveys wash water or filtered water.

Colloids - Microscopic, suspended particles that do not settle in standing water and usually must be removed by filtration or chemical coagulation.

Control Building - Structure at a CVWF that provides a central location for a control panel to operate the facility and for the operator to observe washing operations.

Detention Time - Theoretical time period that a droplet of water takes to flow through a tank or basin.

Dissolved Solid - Solid material that has dissolved in water (e.g., salt).

Dosing Tank - A structure for holding the specific volume of water needed to dose a sand filter.

Dual-purpose Lane - A bath lane that can be used by either tracked or wheeled vehicles. Flexors in a dual-purpose lane are smaller, closer together, and are aligned across the bath lane.

Effective Depth - Usable depth in a sedimentation basin or equalization basin, normally the entire depth of the basin minus the depth allowed for freeboard and for the accumulation of sediment.

Effluent - Water flowing out of a treatment structure.

Energy Dissipater - A structure at the inlet end of a basin intended to slow the velocity of flow into the basin, and sometimes to distribute the incoming flow across the width of the basin.

Equalization Basin - A basin used to accept and store surges of water, and then release the water in a more constant flow over a longer period of time.

Evaporation Rate - The rate at which water is lost from a body of water, or from a system as a whole, due to evaporation.

Filter Charge or Dose - The volume of water pumped to an intermittent sand filter, according to the original Design Analysis for the CVWF.

Filter Loading - The rate at which wastewater is applied to the surface of a filter.

Filter Medium - The material through which water passes in a filter. Sizes of media vary from sand to gravel.

Filtration - A wastewater treatment process in which liquid waste passes through a granular media.

Flexor - Something installed in the bottom of a vehicle bath, usually a steel pipe, to raise the vehicle above bath bottom and to cause up and down movement of the vehicle to improve dirt removal.

Flushers - Pipes placed at the upstream end of trench drains that provide water to push dirt and debris toward the sedimentation basins.

Freeboard - The difference in elevation between the normal maximum operating water level in a basin and the top of the basin wall, berm, or emergency overflow.

Grade - Inclination or slope of surface in terms of a ratio or percentage of vertical rise to horizontal distance.

Hardstand - Impervious surface used as a pavement for vehicular traffic, usually asphalt or concrete.

Hydraulic Loading - Volume of liquid applied per unit time or area to a treatment process.

Impervious - The condition in which a liquid cannot penetrate a material, such as water through concrete or soil.

Inflow - Water or wastewater entering a basin, pond, channel, or other storage or treatment structure.

Influent - Water or wastewater flowing into a basin, tank, or other treatment structure.

Intermittent Sand Filter - A secondary treatment process for primary-treated wastewater, in which wastewater is applied at regular intervals to the surface of the filter.

Lagoon - Pond-like body of water used to treat wastewater using extended sedimentation and biological treatment.

Makeup Water - Water added to a system to compensate for the amount of water lost due to leakage, percolation, evaporation, overspray, carry-off, or release to the environment.

Oil Skimmer - Device used to remove floating oil and grease from the surface of water.

Percolation - Downward movement of water through filter media or soil.

Permeability - Term describing the relative ability of water to move through a soil or other substance.

Potable Water - Water that is safe for human consumption.

Preparation Area - Paved area where Soldiers prepare their vehicles for using a CVWF by removing trash, plugging drain holes, opening bilge pump discharge ports, etc.

Primary Treatment - First phase of wastewater treatment (usually sedimentation), where easily settleable solids, floating debris, and oils are removed from the wastewater.

Sanitary Sewer - Piping that carries wastewater to a domestic wastewater treatment works (sewage treatment plant).

Secondary Treatment - Wastewater treatment following primary treatment in which the majority of the remaining contaminants (suspended or dissolved soil particles or organic material) is removed by a physical and/or biological process.

3 March 2011

Sedimentation Basin - A primary treatment structure, usually a rectangular concrete basin, designed to capture and retain settleable solids and floating material.

Suspended Solids - Solids, usually particles of soil and vegetation, suspended in wastewater.

Total Dissolved Solids - A measurement of the amount of dissolved material in water.

Total Suspended Solids - A measurement of the total amount of filterable (suspended) material in water.

Turbidity - A measure of water clarity.

Valve Box - A structure (often prefabricated concrete) that is used to protect and provide access to a valve that is below grade.

Wash Period - The time during which vehicles are washing at a CVWF.

Wash Station - Usually one of several drive-through lanes where vehicles are washed by Soldiers using hoses on either side of the vehicles.

Water Cannon - A mounted pipe that has freedom of movement (swivel and up and down) that is used by Soldiers to direct large amounts of water at vehicles, usually as the vehicles are entering or exiting a bath.

Water Supply Basin - A basin at a CVWF used to store treated water for recycle back to the wash structures.

Weir - A structure that water flows over that is used to control water depth, or a structure that wastewater flows under that is used to retain floating material.

This publication may be reproduced