

PUBLIC WORKS TECHNICAL BULLETIN 200-1-141
10 JUNE 2014

**IMPLEMENTING STORMWATER AND
EROSION CONTROL TECHNOLOGIES IN
URBAN-TYPE MILITARY RANGE DESIGNS**

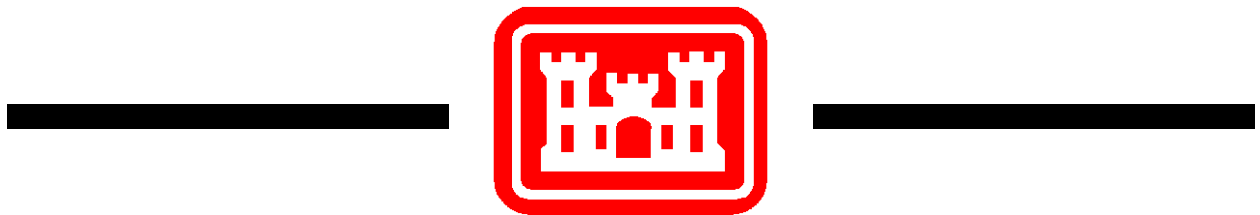

Public Works Technical Bulletins are published by the US Army Corps of Engineers, Washington, DC. They are intended to provide information on specific topics in areas of Facilities Engineering and Public Works. They are not intended to establish new Department of Army policy.

DEPARTMENT OF THE ARMY
US Army Corps of Engineers
441 G Street NW
Washington, DC 20314-1000

CECW-CE

Public Works Technical Bulletin

10 June 2014

No. 200-1-141

FACILITIES ENGINEERING ENVIRONMENTAL

**IMPLEMENTING STORMWATER AND EROSION
CONTROL TECHNOLOGIES IN URBAN-TYPE
MILITARY RANGE DESIGNS**

1. Purpose

a. This Public Works Technical Bulletin (PWTB) provides guidance for successful implementation of sustainable in-field best management practices (BMPs) and low impact development (LID) design technologies within urban training areas (UTAs) on Army installations. This guidance helps US Army installations take a proactive stance to utilize efficient and sustainable designs that will save money in both long-term design and life-span maintenance.

b. This PWTB evaluates the two types of UTAs (permanent and temporary) in terms of training infrastructure requirements and site sustainability. A primary focus is on stormwater management, with solutions and guidance to both initially address stormwater and to correct a site after damage has occurred. A before-and-after review proposes updated in-field design solutions that adhere to current and anticipated regulatory requirements while ensuring an adequate mission-ready training environment. This PWTB showcases methods for identifying water-related erosion and explains the mechanics of that erosion. Problem areas are identified within existing urban training ranges, and associated LID technologies and BMPs are proposed to reduce erosion potentials.

c. All PWTBs are available electronically at the National Institute of Building Sciences' Whole Building Design Guide webpage, which is accessible through this link:

http://www.wbdg.org/ccb/browse_cat.php?o=31&c=215

2. Applicability

This PWTB applies to engineering and training activities at all US Army facilities, especially in the areas of engineering support, range design, and installation management.

3. References

a. Army Regulation (AR) 200-1, "Environmental Protection and Enhancement," 13 December 2007.

b. AR 350-19, "The Army Sustainable Range Program," 30 August 2005.

c. Training Circular (TC) 25-8, "Training Ranges," Headquarters, Department of the Army, 20 May 2010.

d. Executive Order (EO) 13514, "Federal Leadership in Environmental, Energy and Economic Performance," 5 October 2009.

e. Energy Independence and Security Act (EISA) of 2007, codified at Title 42, United States Code (U.S.C.), Chapter 152, Subchapter III, "Energy Savings in Buildings and Industry," Section 17094, "Stormwater Runoff Requirements for Federal Development Projects," 19 December 2007. (Passed by Congress as Public Law [PL] 110-140, Title IV, Section 438.)

f. Army Net Zero Installation Strategy Memorandum, "Participation as a Pilot Army Net Zero Installation," Ms. Katherine Hammack, Assistant Secretary of the Army (Installations, Energy and Environment) (ASA (IE&E)), 11 February 2011.

g. "Department of Defense (DoD) Strategic Sustainability Performance Plan, FY 2013." Washington, DC: DoD Senior Sustainability Officer Under Secretary of Defense for Acquisition, Technology, and Logistics (USD AT&L), 14 August 2013.

4. Discussion

a. Army range designs must now be adapted to meet sustainability goals of several drivers: Army Net Zero, the DoD

10 June 2014

Strategic Sustainability Performance Plan (SSPP), current sustainability-oriented Army regulations, and federal legislation. Compliance issues may arise if management strategies are not in place to respond. One area of maximum impact is stormwater management. Site hydrology has become important due to the concurrence of increasing water requirements by installations and water shortages in certain geographic locations.

b. Current regulations (e.g., EISA 2007) require new federal facilities over 5,000 sq ft to maintain or restore the predevelopment hydrology state of the property with regard to the temperature, rate, volume, and duration of flow. In range design, LID technologies are appropriate to maintain natural hydrologic function during and after range construction, as well as throughout the site's use. Maintaining hydrologic function is particularly relevant to addressing erosion issues and related maintenance at Military Operations in Urban Terrain (MOUT) training complexes, on which this document is focused.

c. AR 200-1 outlines environmental policies and designates program requirements in order to comply with federal policies. Chapter Four, Section E, ("Stormwater Management") pertains to policy controlling or eliminating sources of pollution to prevent contamination of water bodies or ground water. A second policy uses abatement measures for nonpoint source runoff from facilities, construction, and land management activities. Program requirements include obtaining specified permits, providing stormwater management plans, and providing stormwater pollution prevention plans.

d. AR 350-19 assigns responsibilities and provides policy and guidance for the management and operation of ranges and training lands. This regulation supports US Army long-term sustainability and utility to meet the national defense mission with core programs such as the Army's Sustainable Range Program, Range and Training Lands Program, and Integrated Training Area Management Program.

e. TC 25-8 provides a guide for operating and developing Army Ranges. The publication is a working document providing guidance for trainers, range and mobilization planners, engineers, coordinates, and mandated range project review boards. TC 25-8 is the primary guide for the development plans for installations.

f. EO 13514 establishes agency objectives to improve water use efficiency and management related to stormwater runoff. The

EO requires agencies to issue guidance on the implementation of Section 438 of EISA (see next item, 4g) relating to the maintenance or restoration of site hydrology to predevelopment conditions.

g. A memorandum from the office of Ms. Hammack, U.S. Assistant Secretary of the Army (Installations, Energy, and Environment), was the first step in the Army's Net Zero Installation Strategy. On 22 May 2013, an Army release about "Net Zero Progress Report 2012"¹ excerpted the following statements from the report to show the continued importance of the program: "The Army's Net Zero Initiative is a holistic strategy that builds upon long-standing sustainable practices and incorporates emerging best practices in building an Army-wide community to manage energy, water, and waste at Army installations. The Net Zero Initiative is recognized as a force multiplier enabling the Army to appropriately steward available resources, manage costs, and provide Soldiers, families and civilians with a sustainable future."

h. In his letter within the 2013 DoD Strategic Sustainability Performance Plan (SSPP, dated August 2013),² the DoD's Senior Sustainability Officer wrote: "To successfully execute the DoD mission, our Military Departments must have the energy, land, air, and water resources necessary to train and operate, today and in the future, in a world where there is increasing competition for resources. Sustainability provides the framework necessary to ensure the longevity of these resources by addressing energy, environmental, safety, and occupational health considerations. Incorporating sustainability into DoD planning and decision-making enables us to address current and emerging mission needs and consider future challenges."

i. This PWTB allows an understanding of the two typical UTA types (permanent and temporary) and associated sustainment issues, with a primary focus on stormwater management. The following lessons were learned from completing this work:

- Data for the hydrologic analysis is easily obtained via the Web and/or from installation-level high-resolution LiDAR databases; this means there is minimal need for site visits to collect data.

¹ http://www.army.mil/article/103842/Army_releases_2012_Net_Zero_Progress_Report/

² <http://www.denix.osd.mil/sustainability/loader.cfm?csModule=security/getfile&pageid=35931>

10 June 2014

- ArcGIS can be used to accurately identify areas of hydrological importance on both types of UTAs.
- Many LID technologies and BMP strategies are available to reduce the types of soil erosion occurring across UTAs.
- Designs for reducing erosion on UTAs need to be created on a case-by-case basis so they are specific to the problem, location, and environment.
- LID technologies and BMP strategies can be very cost efficient, especially when their long-term effectiveness and sustainability is considered. Even with added maintenance responsibilities associated with such modifications, resulting costs remain cheaper than non-modified UTAs after erosion damage has occurred and repairs are carried out.
- Using LID technologies and BMP strategies creates a safer and more stable field training environment by preventing gullies and other erosion-related safety hazards.

j. The designs suggested in this PWTB promote infrastructure stability and ensure that buildings, roads, and ditches will continue to support training throughout the life span of each UTA.

k. Appendix A contains general background information on the land uses and water erosion issues commonly observed in UTAs. This section also includes descriptions of the two UTA types currently being utilized on Army installations, and explains the selection of the sample sites that were chosen to represent "typical" UTAs.

l. Appendix B explains the study's approach including the methods of data collection and site analysis results. This appendix also includes narrative and graphics to explain the site development, topography, soil types, and hydrological modeling that is relevant to predicting and preventing erosion caused by stormwater.

m. Appendix C illustrates examples of land degradation based on site analyses. Each example is site-linked, reflecting a real-world issue. Before-and-after design reviews are included to provide analysis of areas on each UTA site where erosion or other land sustainment issue was identified. Each problem area is described in detail with an explanation of the relevant

10 June 2014

mechanisms of stormwater erosion. A solution for each area is proposed to mitigate stormwater impacts and erosion, and technical drawings are included to illustrate proper implementation for each design. Design solutions are inspired from LID technologies and other tried-and-true BMPs that are proven to reduce erosion potentials while having the ability to persist in military field training environments. However, not all solutions presented are practical for all geographical regions, soil types, and/or eco-regions; designs should be evaluated by a local professional engineer for applicability and implementation.

n. Appendix D provides a discussion of UTA differences and related maintenance requirements, along with the lessons learned from this work.

o. Appendix E contains a table of abbreviations used in this PWTB, along with their meanings.

1. Points of Contact

a. Headquarters, US Army Corps of Engineers (HQUSACE) is the proponent for this document. The point of contact (POC) at HQUSACE is Mr. Malcolm E. McLeod, CEMP-CEP, 202-761-5696, or e-mail: Malcolm.E.Mcleod@usace.army.mil.

b. Questions and/or comments regarding this subject should be directed to the technical POC:

US Army Engineer Research and Development Center (ERDC)
Construction Engineering Research Laboratory (CERL)
ATTN: CEERD-CN-N, Anne Koster
PO Box 9005
Champaign, IL 61826-9005
Tel: (217) 419-8379
FAX: (217) 373-7266
e-mail: Anne.P.Koster@usace.army.mil

FOR THE COMMANDER:

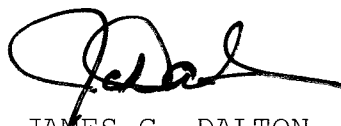

JAMES C. DALTON, P.E., SES
Chief, Engineering and Construction
U.S. Army Corps of Engineers

APPENDIX A: INTRODUCTION

The fieldwork and investigation related to this PWTB was conducted by Casey Campbell, Anne P. Koster, and Heidi R. Howard of the Ecological Processes Branch at ERDC-CERL (CEERD-CN-N).

Background

With recent years' training efforts involving an increase in urban combat scenarios, the US Army has been rapidly constructing and expanding the type of training areas dedicated to preparing soldiers for urban combat. Many of these urban training areas (UTAs) consist of buildings, roads, vehicles, fences, and other items common to urban environments.

UTAs often create extensive impermeable surfaces as well as areas of concentrated vehicular impacts in hydraulically sensitive environments. These impermeable surfaces are due to either a lack of stormwater infrastructure in the area or improper initial siting of the UTA. UTAs are generally located in undeveloped sections of training areas on Army installations. Site vegetation usually is typical for the particular Army installation, and the site is generally not improved during the installation of UTAs. The concentrated vehicular impacts imposed on UTAs can lead to increased land degradation if best management and sustainable practices are not used.

UTAs discussed in this report are divided into two categories, temporary and permanent. This division is due to the inherent differences in each type's construction, design life, and site management.

Report Content Overview

In addition to this introduction, this PWTB includes appendices that cover Data Collection and Site Analysis (Appendix B), UTA example problem areas with proposed solutions (Appendix C), and a discussion of UTA design differences and related maintenance requirements plus lessons learned from this study (Appendix D).

Temporary UTAs

As the name implies, temporary UTAs are more dynamic and reconfigurable than their permanent counterparts. In general, these areas contain movable and/or disposable structures such as (a) buildings created from shipping containers, high-density foam, or plywood; (b) divider walls made from interlocking

10 June 2014

concrete blocks; and (c) unpaved roads. This type of UTA is generally modeled after urban environments found in the Army's most current operating environment. Other "props" and decorative objects are often creatively included in these types of sites to boost the soldier's perception of a realistic operational environment. These sites are built quickly, with a short life expectancy in mind. However, due to training needs, the life span of temporary UTAs sometimes is stretched beyond the initial intended timeframe. The site is then reworked, and existing structures are reused to create new training scenarios. This reworking is a helpful and money-saving strategy because typically, only minimal funds are provided for construction and maintenance of temporary UTAs.

The extended use of temporary sites will affect the quality of site structures over time if maintenance issues are not addressed in a timely manner. The temporary UTA chosen for this study is shown in Figure A-1 via an aerial view of the site and photo insets of the on-site buildings.

Permanent UTAs

Permanent UTAs consist of robust structures constructed with concrete or cinder-block foundations and paved roads; extensive earth work can be involved. In general, permanent UTAs are modeled after urban environments in developed nations, have a long life expectancy, are funded as permanent structures, and carry with them long-term maintenance schedules. The buildings are generally weatherproof and secure so that they can be outfitted with audio and visual technologies to assist trainers in providing After Action Reviews (AARs) of training exercises. Permanent UTAs also experience high volumes of training activities by many different units and elements of the military. The permanent UTA chosen for this study is shown in Figure A-2 via an aerial view of the site and photo insets of the site's buildings.



Figure A-1. Aerial view of temporary UTA site example, with the site's buildings shown in photo insets (source: Google Maps for aerial view; ERDC-CERL for photos, 2013).



Figure A-2. Aerial view of permanent UTA site example, with the site's buildings shown in photo insets (source: Google Maps for aerial view; ERDC-CERL for photos).

APPENDIX B: DATA COLLECTION AND SITE ANALYSIS

Study Approach

Within this study, initial background data collection was followed by a detailed on-site survey. The collected data catalogued site aspects and environment, while noting status of soil, vegetation, hydrology, and potential sustainability or maintenance issues. An on-site topographic survey was essential, as many erosion or environmental maintenance issues can be easily overlooked or are not visible due to vegetation or scale incompatibility when viewed from other low-resolution perspectives (e.g., satellite imagery).³ Extensive photographs were also taken to document site characteristics as well as any areas noted to be affected by erosion or other adverse impacts.

Site Assessment

In order to perform an accurate hydrological assessment of the UTAs, a detailed survey was done using a real-time kinematic (RTK) global positioning system (GPS) to collect point elevations (with 1.5 cm accuracy) across the areas of interest. The elevations of spaces between points were found using kriging to develop an accurate topographic map that shows 1-ft contour lines. Culverts were included to ensure creation of an accurate hydrologic model. It should be noted that, with the increased availability and high-resolution of light detection and ranging (LiDAR) data on military installations, accurate topographic maps can be obtained without the need for an on-site survey.

Soil Survey

Accurate knowledge of soil data is the key to creating a successful erosion-prevention strategy. Detailed soil maps that contain information on infiltration rates, erodibility, and potential for supporting vegetation should be consulted for such an analysis. Soil maps for the example sites used in the study were obtained from the United States Department of Agriculture Natural Resources Conservation Service (NRCS), which provides a free web-based soil-mapping service. The soil maps display map unit numbers which are linked to the soil type and can subsequently be used to look up information about the site's soil and related properties. In addition to obtaining

³ Note that authors did not have access to adequate high-resolution LiDAR datasets, which could have been a valid option.

10 June 2014

informative soil data, someone with experience managing soil should be on hand to ensure proper interpretation.

Soil Information for Temporary UTA Example

Figure B-1 shows the soil map for the temporary UTA example. The soil consists of Wymore Silty Clay Loam (map unit 7681) with 1%-3% slopes, some of which is classified as eroded (map unit 7682). Additional information from the NRCS indicates that Wymore Silt Clay Loam is well drained with a land capability class of 2e. These details mean that the soil supports vegetation, but is at increased risk of erosion.

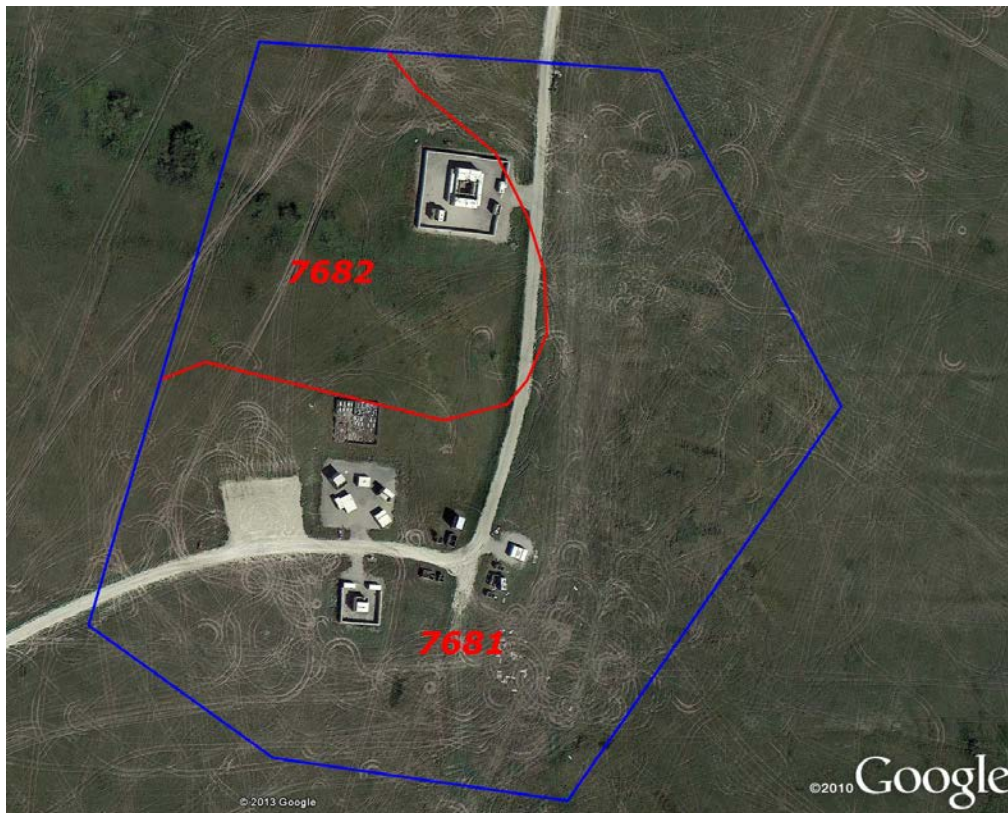

Figure B-1. Soil map for temporary UTA example (source: Google Maps, enhanced by ERDC-CERL).

Soil Information for Permanent UTA Example

Figure B-2 shows the soil map for the permanent UTA example. This site is composed primarily of Dwight-Irwin Complex soil (map unit 4625), with 1%-3% slopes and Irwin Silty Clay Loam soil (map unit 4673). Both soils are moderately well drained with a land capability class of 4e. These details mean that the soil is suitable for vegetation but susceptible to erosion. The soils are also considered to be supportive to agriculture, which indicates a history of being subjected to agricultural

10 June 2014

practices. These agricultural practices could include the addition of designed landscape-level water-management strategies that would have been instituted in the form of ditches, drainage tiling, and/or land terraces.

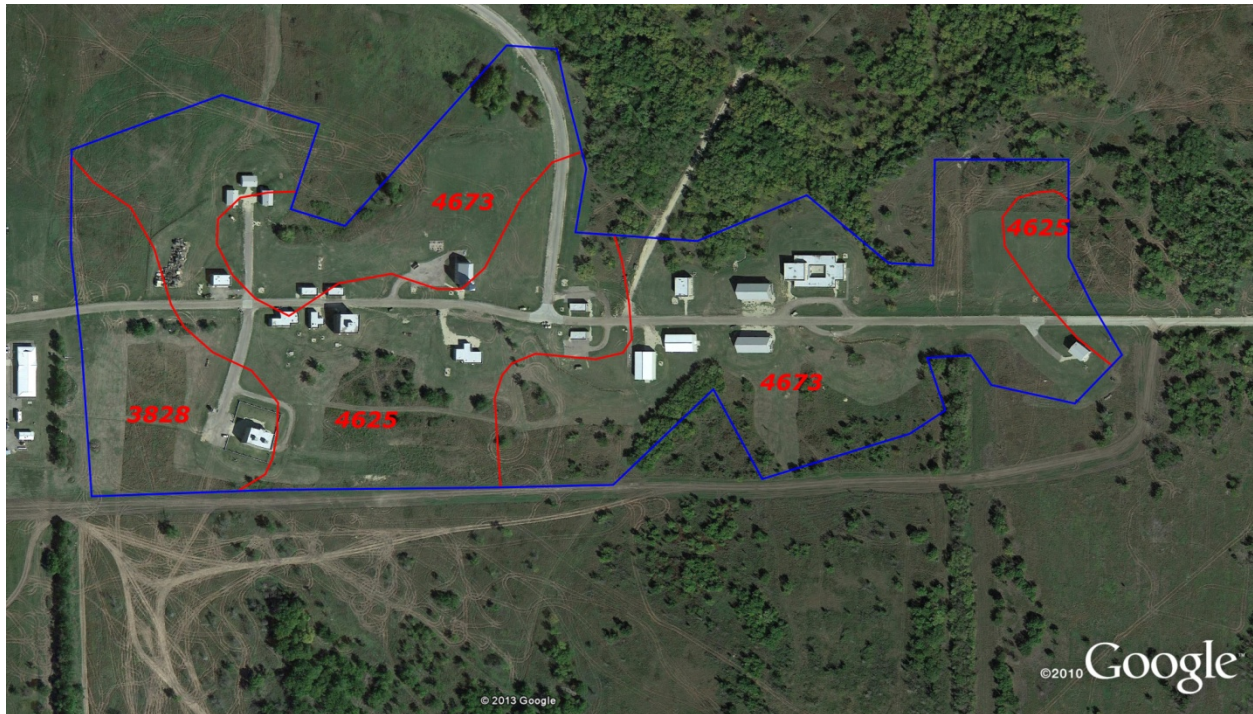

Figure B-2. Soil map for permanent UTA example
(source: Google Maps, enhanced by ERDC-CERL).

Hydrologic Analysis

Regardless of any and all mitigation techniques used, a storm may exceed the capability of the stormwater system to handle the associated flow. It is important to understand the relationship between the costs of design and construction versus the mitigated and unmitigated risks. It is a delicate balance to build a facility which is usable and sustainable while still maintaining an affordable cost. Most risks can be mitigated at a cost (not necessarily limited to financial cost); however, it is critical to identify the appropriate level of risk which is willingly accepted by the Army when developing these facilities.

A hydrologic analysis was performed on each site to identify areas of high risk for erosion based on the area contributing runoff within the UTA. ArcGIS⁴ software was used for analysis of

⁴ ArcGIS 10.2.1 for Desktop, Esri (<http://www.esri.com/software/arcgis>); use of this product does not constitute an endorsement by the US Army Corps of Engineers.

10 June 2014

elevation points collected during the initial site survey and for map generation. The process of making these maps began with importing the elevation points and creating a three-dimensional (3D) topographic terrain model of each site. Once the terrain models were developed, hydrology tools contained in the ArcGIS Spatial Analyst toolbox were utilized to create flow accumulation maps to show areas of increased overland and concentrated water flows. Because the designs presented are not site-specific, no precipitation models were used during this analysis. However, when designing and implementing LIDs and BMPs for actual applications, it is important to properly size them (based on design storms) to ensure their viability and effectiveness.

One item to note about the hydrologic analysis of the temporary site is the importance of mapping culverts. The topographic map only displays the elevation of the soil surface and does not accurately calculate the flow accumulations in areas with culverts due to the culvert's function of moving water underground. For the purpose of creating accurate flow accumulation maps, the soil surface above the culvert was lowered to the bottom of the culvert to ensure the function of the culverts was captured within the analysis.

The resulting hydrologic analysis map of the Temporary UTA is shown in Figure B-3. The maps of other problem area sections resulting from the hydrologic analysis of the Permanent UTA are shown in Figure B-4 through Figure B-7. Note that due to the large size and shape of the permanent UTA example site, it was divided into four sections for the purpose of showing detail while still having maps fit on pages of this PWTB. Maps for both example sites also contain markers for the location of each identified "problem area" within each of the two UTA types. These problem areas will be analyzed in Appendix C. The maps also contain match lines for continuity of land sections, as well as buildings and roads for orientation. The results from the site survey and hydrologic analysis are displayed on the maps as topography lines and flow accumulation networks, respectively.

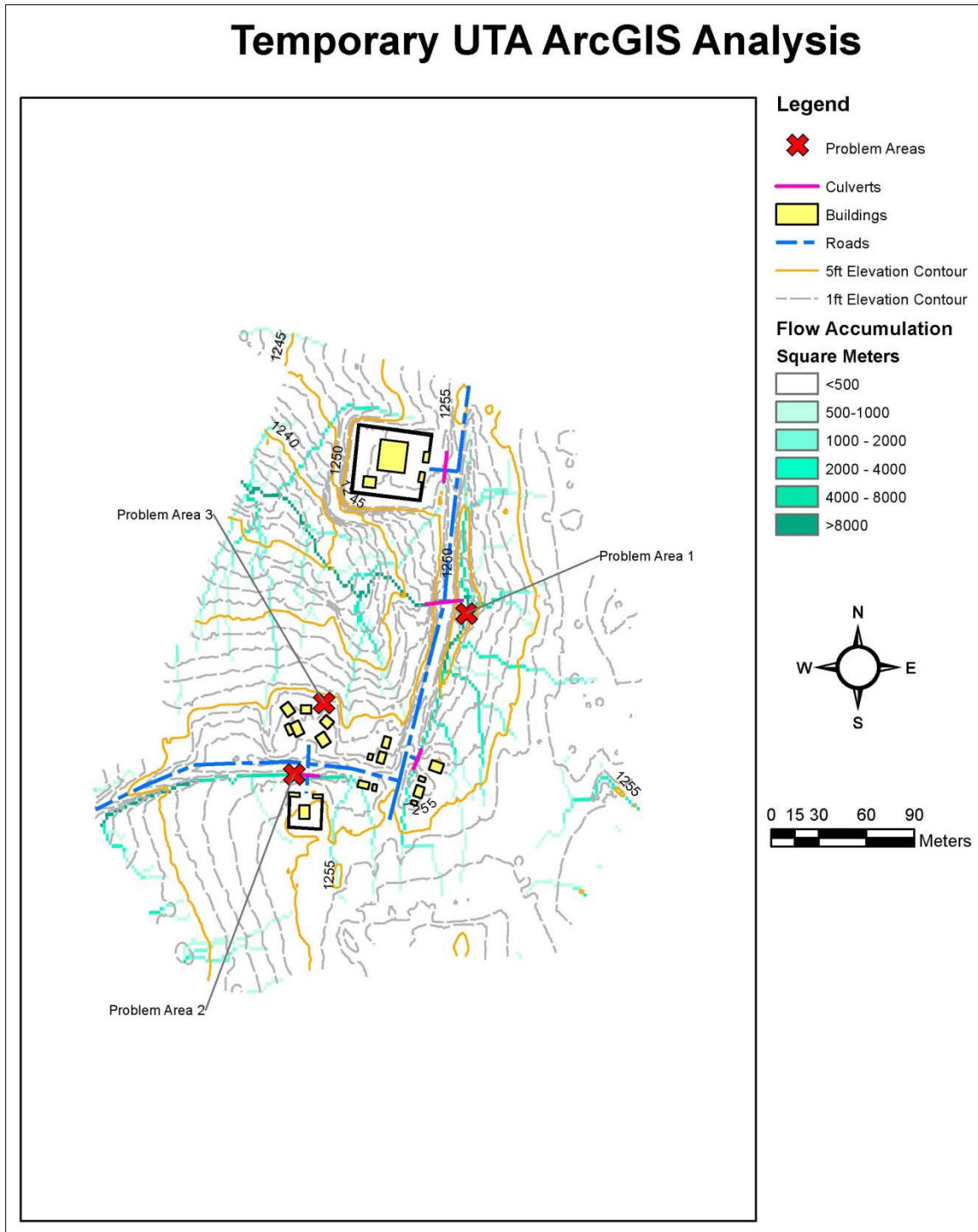

Figure B-3. Hydrologic analysis map for temporary UTA example (ERDC-CERL).

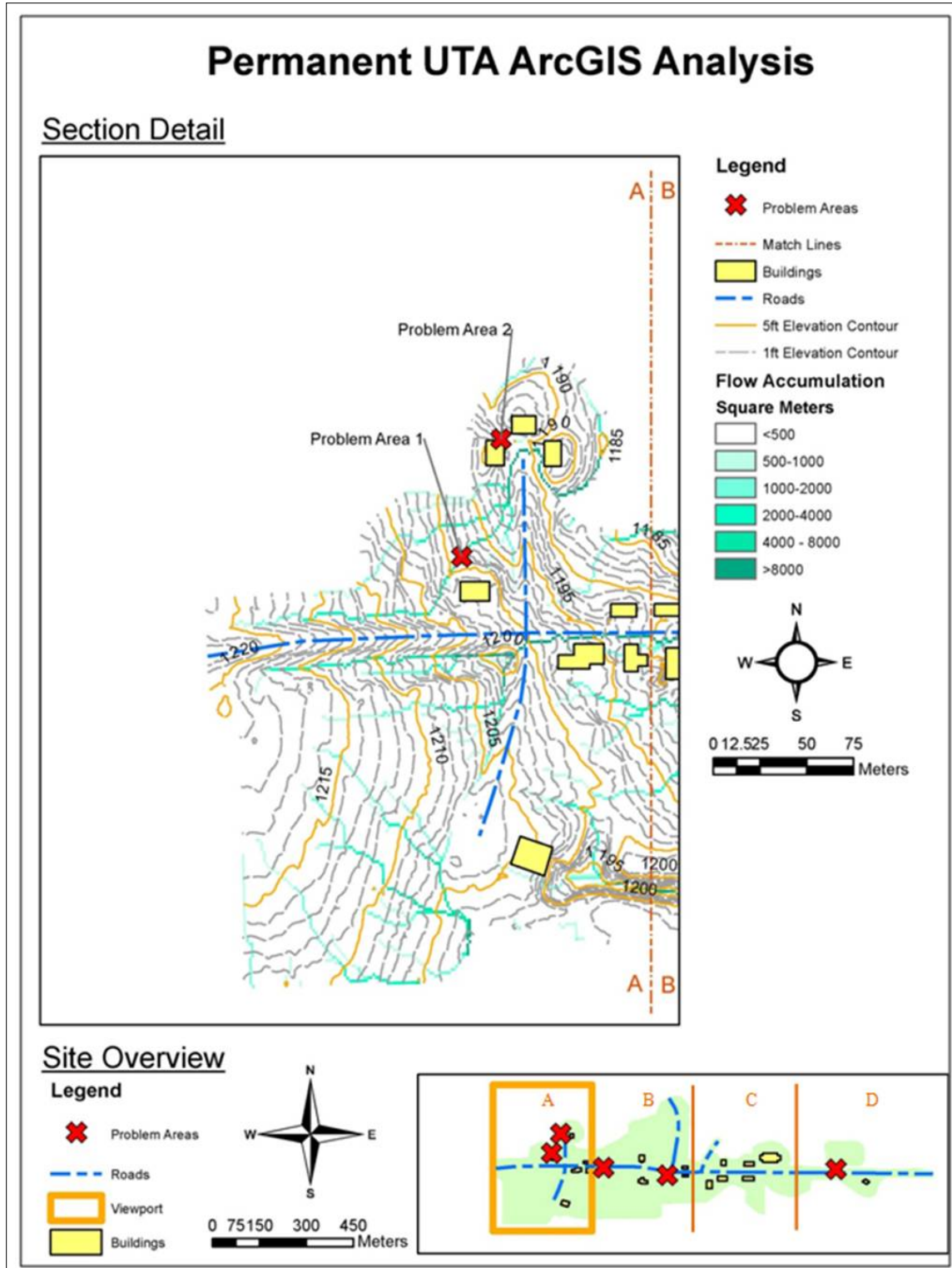

Figure B-4. Hydrologic analysis map for Section A of Permanent UTA example site (ERDC-CERL).

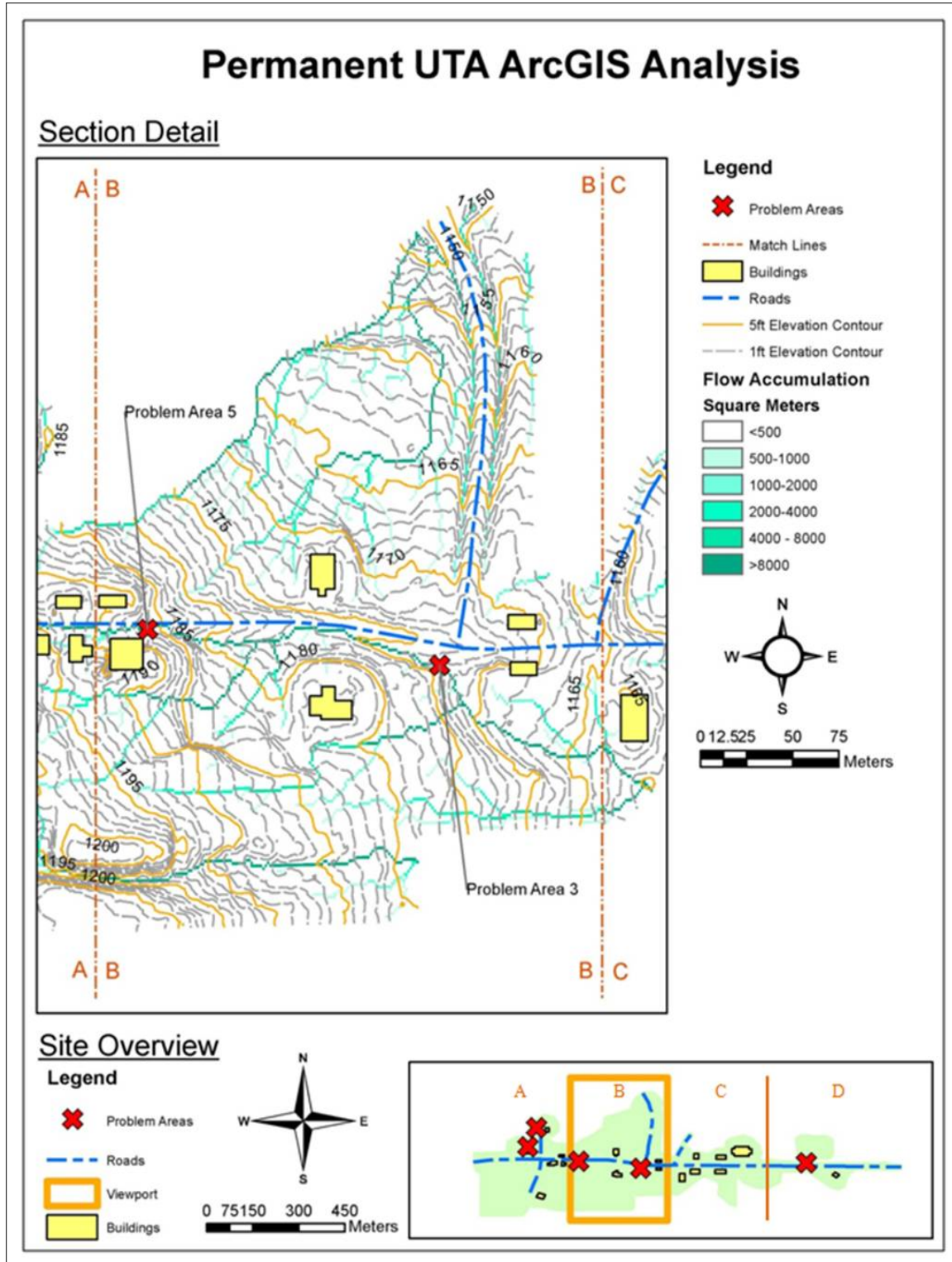

Figure B-5. Hydrologic analysis map for Section B of Permanent UTA example site (ERDC-CERL).

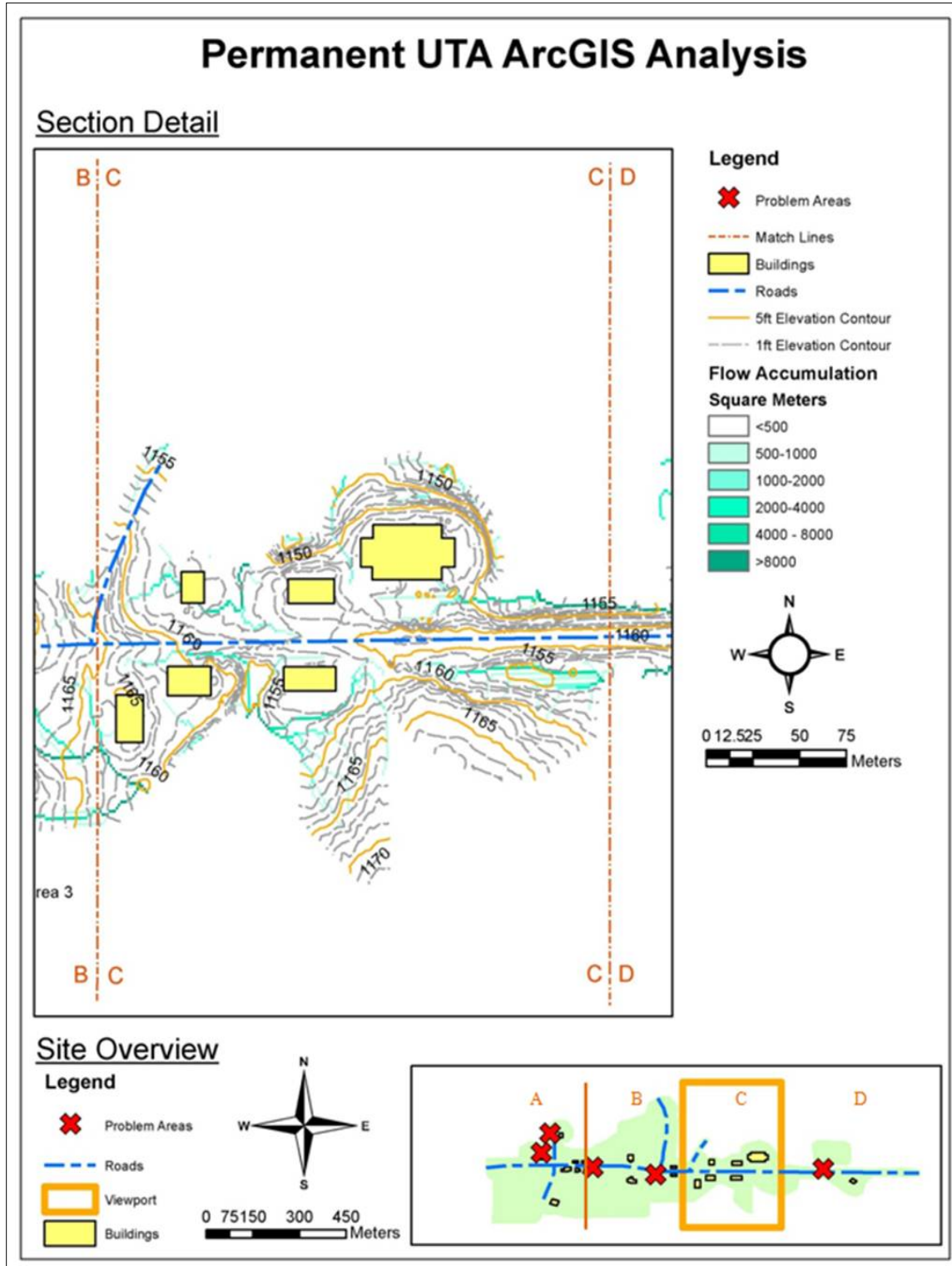

Figure B-6. Hydrologic analysis map for Section C of Permanent UTA example site, showing no problem areas (ERDC-CERL).

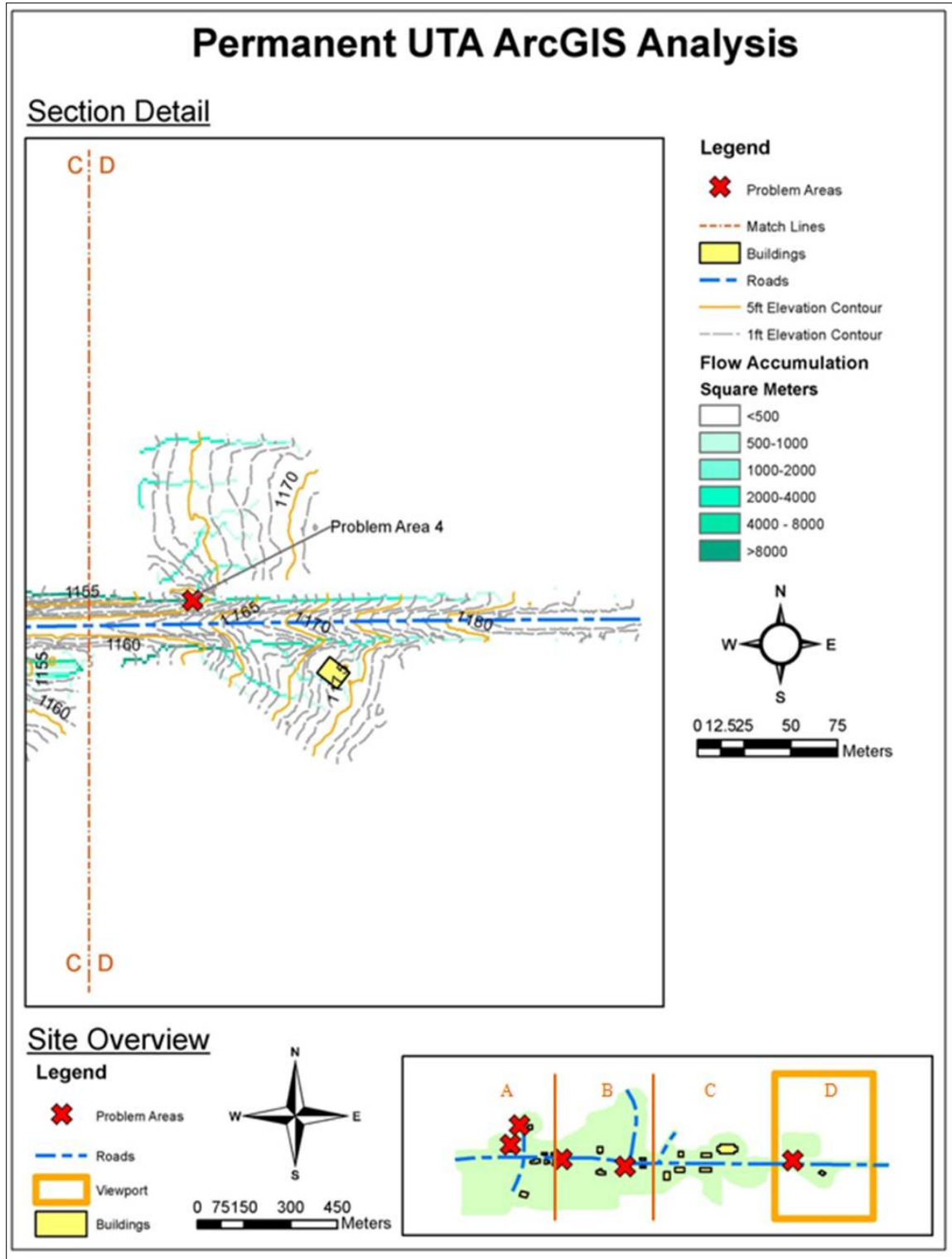

Figure B-7. Hydrologic analysis map for Section D of Permanent UTA example site (ERDC-CERL).

1 **APPENDIX C:**
2 **EXAMPLE UTA PROBLEM AREAS WITH PROPOSED SOLUTIONS**

3 **Presentation Structure**

4 In this appendix, examples of erosion problems identified with
5 the hydrologic analysis are divided by site type and then
6 referred to by problem number as previously shown (Figure B-3
7 through Figure B-7 in Appendix B). In each example, three
8 subsections will be presented: the problem description, proposed
9 solution, and technical drawing(s) of the proposed solution's
10 design.

11 Each problem description contains a set or multiple sets of
12 pictures illustrating the areas impacted by erosion. The picture
13 set(s) will show the original image alongside a graphically
14 altered version of the same image. The altered image will
15 utilize highlighting to aid in the explanation of key areas and
16 issues being illustrated. The highlighted colors and function
17 are explained relative to each image. Each problem area
18 subsection will also explain the cause and mode of erosion being
19 shown in the image.

20 The solution subsection describes site and design modifications
21 that would help to reduce erosion through LIDs or specific
22 sustainable BMPs. The section will also briefly explain how each
23 particular strategy was chosen based on site utilization during
24 training events.

25 Lastly, a technical drawing in each problem area subsection
26 shows how the strategy or technology described could be
27 installed and/or implemented. It should be noted that the design
28 solutions shown in the technical drawings have been custom-
29 designed to correlate with specific site and anticipated use.
30 Therefore, when implementing such LID technologies or
31 sustainable BMP solution designs, the dimensions and design
32 modifications should be done the same way - i.e., customized per
33 environment, context, and purpose to insure the functionality of
34 the chosen solution.

35 Table C-1 gives an overview of the problem areas and solutions
36 that are discussed in this appendix.
37

1
2

Table C-1. Summary of UTA types, problem areas, solutions, and design highlights.

UTA Type	Problem Area	Problem Description	Solution Description	Solution Design Highlight
Temporary	1	Shallow ditch was trafficked when soil was wet; causes ruts	Avoid trafficking when wet; provide a hardened surface	Add layer of riprap to bottom and sides of ditch
	2	Culvert damage or malfunction causes water to overtop the road	Replace with new culvert and add grass buffer	Culvert outlet redesign plus minimum 24-in. buffer above culvert near road
	3	Herbicide treatment drift affects perimeter vegetation near gravel pad and causes erosion	Establish a vegetative buffer when spraying; use proper spray techniques to avoid drift	Design proper buffer strip with 3-ft transition area
Permanent	1	Rill formation by water runoff from impervious surface	Reshape through grading; till area and reseed cover	Rolled erosion control product channel
	2	Soil loss at foundation due to erosion	Add gutter to building to convey water away from foundation; install infiltration trench	Gutter and infiltration trench
	3	Gully formation, expansion; resulting large population of broadleaf vegetation	Redesign gully to slow water and be less steep; revegetate	Parabolic ditch with rock center

UTA Type	Problem Area	Problem Description	Solution Description	Solution Design Highlight
	4	Compaction and vegetation loss due to heavy traffic through wide roadside ditch.	Stabilize ditch by adding low-water crossing to protect underlying soil from erosion	Prefabricated cable concrete OR worn tank track alternative to stabilize ditch crossing
	5	Natural water flow obstructed, causing roadside erosion	Add ditch to both sides of road and culvert under driveway crossing	Contoured ditch and culvert

1

2 **Temporary UTA: Problem Areas**

3 *Temporary UTA Problem Area #1*

4 **Problem: Ruts**

5 The two pictures on the left of Figure C-1 show a ditch that
 6 vehicles have crossed when soil conditions were wet. One
 7 photo has been highlighted with red, showing where vegetation
 8 was removed via subsequent rutting (upper right). The blue
 9 highlights (lower right photo) indicate the subsequent change
 10 in vegetation type that occurred after past wet rutting
 11 events. The change in vegetation type is an indication of
 12 increased soil moisture and changed soil structure in the
 13 impacted area.

1

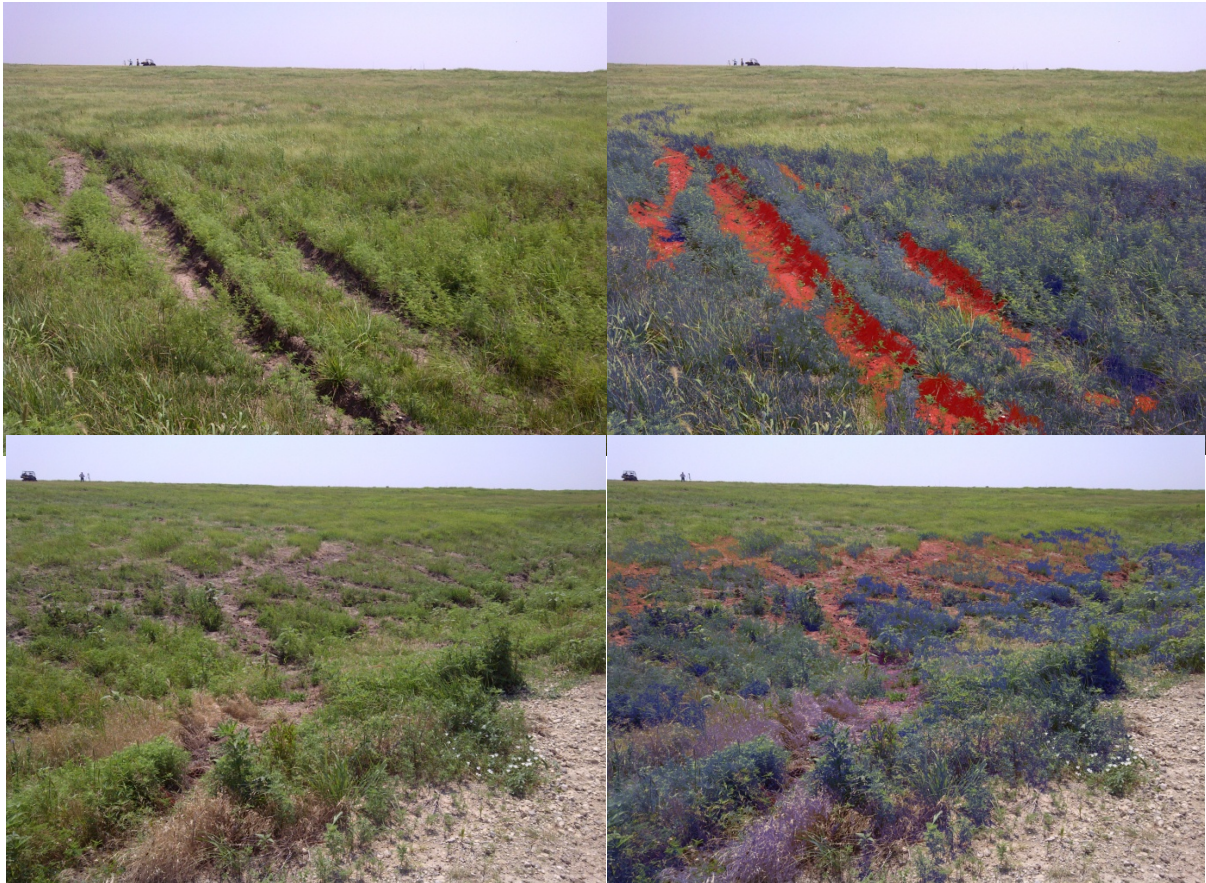

2

3

4

5

6

Figure C-1. Temporary UTA, Problem Area #1 - a ditch trafficked by vehicles when soil conditions were wet. Red areas on right-side photos indicate vegetation removed via rutting; Blue indicates a subsequent change in vegetation type (ERDC-CERL).

7

8

9

10

11

12

13

14

15

16

17

18

19

The deep rutting and subsequent ditch formation indicate that the soil compaction caused by vehicles was amplified due to the wet soil conditions, because the soil is more vulnerable to damage and deformation under heavy loading when moisture content is higher. When compaction occurs, soil particles are forced closer together. This outcome decreases the pore space within the soil, which in turn decreases the amount of water and air that can be retained in the soil. Depending on the loading type and dynamics, the soil compaction might be restricted to the surface zone or may have penetrated deeper within the soil profile. The reduced amount of space between soil particles also impedes root penetration. Both factors lead to restriction of vegetative growth.

20

21

22

23

Surficial soil compaction is generally easy to alleviate. In soils where freeze/thaw cycles exist, this natural process can break up and loosen shallow compacted areas and allow vegetative growth to repopulate affected areas. Mechanical

10 June 2014

1 loosening or compaction break-up can also be induced by use
2 of agricultural implements (tines, ploughs, harrows, etc.).
3 However, deeper soil compaction can be quite difficult to
4 alleviate. If mechanical means can penetrate deeply enough,
5 they can be utilized to break up compaction pans and create
6 open spaces for water infiltration and root penetration,
7 which will slowly reestablish proper soil structure
8 throughout. If mechanical means are not possible, natural
9 soil processes will have to be relied upon. The effectiveness
10 of natural processes may be greater in certain areas than
11 others, depending on soil type and climate; the latter drives
12 the freeze/thaw depths that the soil experiences seasonally.
13 In other cases, deep compaction pans may persist which will
14 negatively affect vegetative growth and increase the
15 potential for erosion.

16 The ruts themselves have several characteristics that
17 increase the amount of soil erosion. First, the vegetative
18 cover has been destroyed, leaving the soil particles open and
19 susceptible to detachment and transport during rain events.
20 With soil particle removal, as well as a concentrated flow
21 within the rutted channels, inter-rill erosion quickly
22 occurs. This erosion will lead to gully formation if not
23 checked and will create a safety hazard for personnel and
24 equipment. Also, the ruts create areas where water is able to
25 pool, which elicits a change in vegetation type and can
26 affect composition of vegetation. In some cases, these
27 changes in vegetation can encourage invasive species
28 colonization.

29 **Solution: Traffic avoidance or addition of hardened surface**

30 The best solution for this type of rutting problem and
31 subsequent creation of ditches is to prevent the
32 circumstances causing the ruts. When possible, vehicles
33 should avoid areas where large amounts of water are conveyed
34 as well as areas that hold water during and after rainfall
35 events. Unfortunately, since this is an active training site,
36 and based on the quantity and patterns of tracking shown in
37 the aerial image of the site, such vehicle trafficking is
38 likely unavoidable.

39 In this situation, where vehicles do need to cross ditches
40 and/or wet areas, the site would benefit from design
41 improvements (Figure C-2). The goal of any design in this
42 scenario would be to provide a hardened surface to protect
43 the soil below and thus prevent vehicles from degrading the
44 area. One of the simplest design solutions involves the

10 June 2014

1 addition of a layer of riprap at the bottom and sides of the
2 ditch. The riprap would greatly reduce impacts from vehicle
3 maneuvers by creating a hard surface for vehicles to travel
4 over, while still allowing water to flow through the ditch
5 and drain from the area. The result will be reduced rutting
6 and less erosion of the underlying soil.

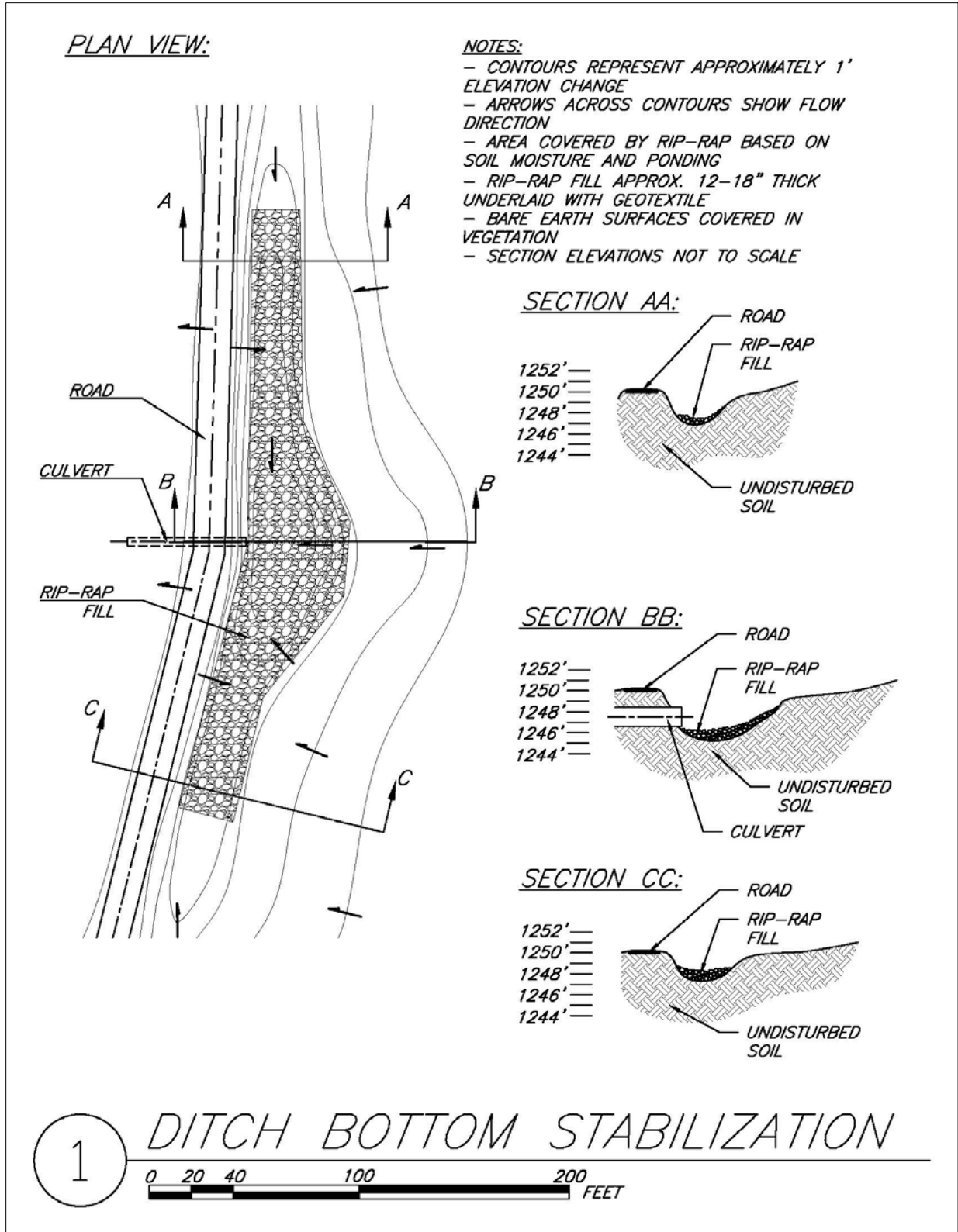

1
 2
 3

Figure C-2. Ditch bottom design improvement for soil/ditch stabilization (ERDC-CERL).

10 June 2014

1 *Temporary UTA Problem Area #2*

2 **Problem: Culvert damage or malfunction**

3 The picture on the left of Figure C-3 shows a culvert that
4 has been crimped by a vehicular traffic over one end. With a
5 partially crimped and collapsed structure, the culvert can no
6 longer effectively convey water underneath the road, and
7 water instead flows across the top of the road. This flow
8 then erodes the road's surface. The picture on the right
9 illustrates the erosion that has separated the gravel fines
10 from the larger rocks. The larger-sized aggregate remains
11 around the top and sides of the culvert (area in red), and
12 the smaller rocks have been washed into the depression below
13 the culvert (area in blue).



14
15 **Figure C-3. Damaged culvert blocks subsurface water passage, causing water to**
16 **flow over the road. Subsequent erosion of gravel is indicated by larger rocks**
17 **remaining at the top and sides (red area), and smaller rocks being washed**
18 **into the depression (blue area) (ERDC-CERL).**

19 Culvert malfunctions are a common and easily identified
20 issue. Generally, culvert malfunction results in a road-
21 surface erosion or stability issue. In every case, the main
22 aim should be to identify the malfunction's root cause. To
23 determine this, several elements and design parameters of the
24 existing culvert structure should be checked. First, the
25 culvert should be checked for any obstructions which would
26 prevent it from functioning properly. Physical deformations
27 of the culvert structure can also obstruct water flow and

10 June 2014

1 should be noted if present. If obstructions are found, they
2 should be removed so that the culvert can convey water as
3 designed. If the culvert has no visible obstructions or
4 deformations, but the road surface is still being eroded or
5 otherwise affected, the culvert may not be properly sized for
6 the amount of water it has to transport. In this case, the
7 culvert should be replaced with a larger culvert capable of
8 moving the correct amount of water. The larger culvert will
9 prevent water from bypassing the culvert and flowing over the
10 road.

11 **Solution: Replacement, design improvements**

12 In the case shown in Figure C-3, the culvert has been
13 deformed in a crimple at its outlet. The culvert should be
14 replaced with a longer culvert. Additionally, in order to
15 prevent this from happening again, design improvements should
16 be made (Figure C-4). One improvement shown would be adding a
17 24-in. or wider grass buffer along the road above the
18 culvert. This buffer will encourage drivers to avoid driving
19 over the end of the culvert. A second recommendation involves
20 placing boulders on each side of the culvert inlet or outlet.
21 This recommendation prevents vehicles from making contact
22 with the end of the culvert by placing a physical barrier
23 between vehicles and the culvert ends.

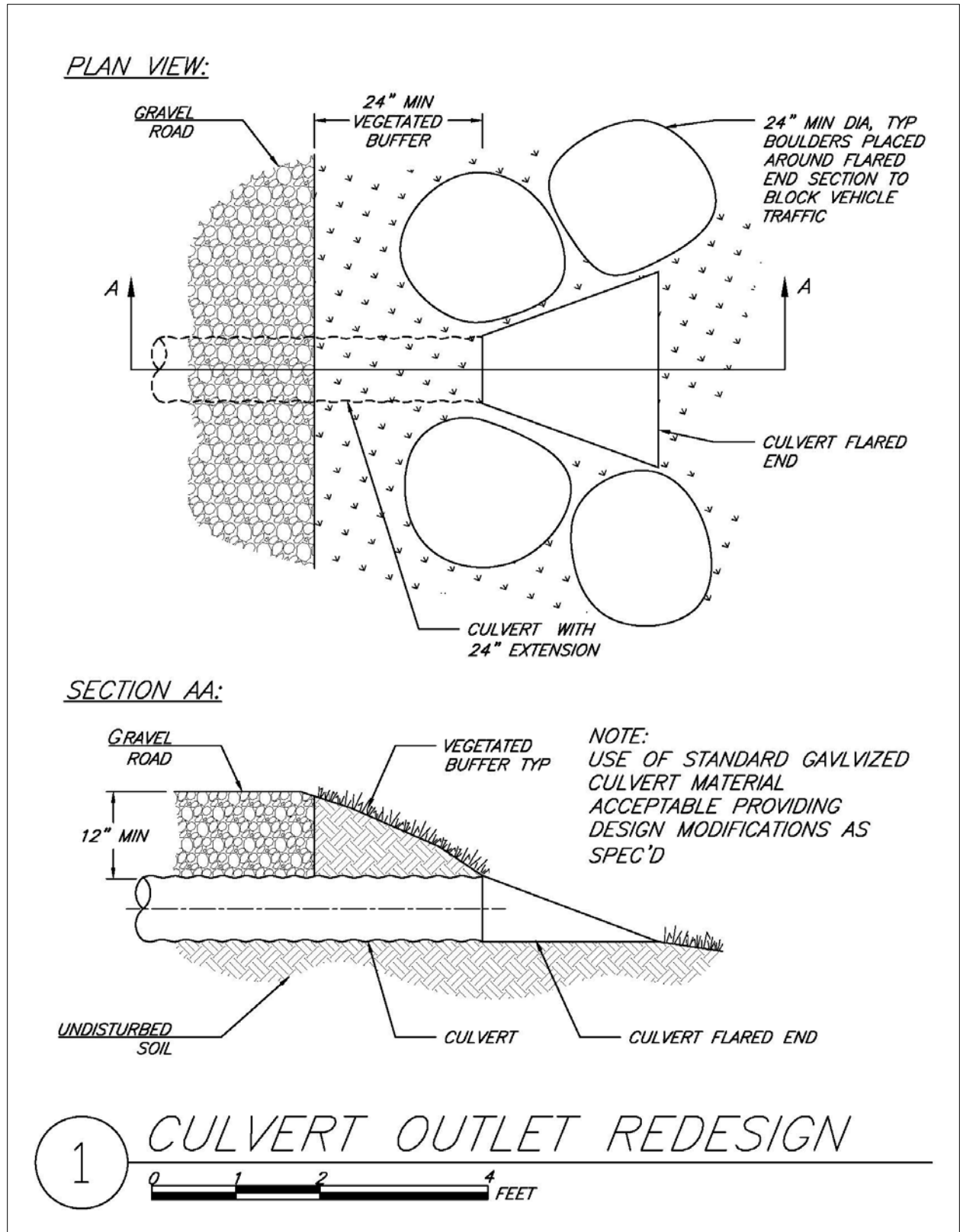

1
2
3

Figure C-4. Culvert outlet redesign as solution for damaged culvert area (ERDC-CERL).

10 June 2014

1 *Temporary UTA Problem Area #3*2 **Problem: Herbicide treatment drift**

3 The picture pair in Figure C-5 shows a gravel pad on which
4 temporary training structures (not shown in image) were sited
5 and/or equipment stored in the past. In this instance, the
6 erosion problem originates from the gravel pad being treated
7 with herbicide to control undesired vegetation. As can be
8 seen, the herbicide was applied in a manner that resulted in
9 drift along the perimeter of the sprayed area. The drift
10 impacted perimeter vegetation and resulted in loss over time,
11 leaving bare soil (blue areas in altered image) and
12 vegetation death (red areas in altered image). Without
13 vegetated slope protection, the soil particles are
14 susceptible to detachment during a precipitation event, which
15 has led to noticeable sheet erosion around the pad perimeter.

16 **Solution: Vegetative buffer strip**

17 When herbicide is being applied to gravel pads, the
18 application should allow for a vegetative buffer strip around
19 the edge of the pad (Figure C-6). The addition of a buffer
20 would result in a soil surface that is covered by both gravel
21 and vegetation. This practice would allow vegetation to
22 remain along the edge of the pad, thus protecting the soil by
23 minimizing erosion.

24 In order to establish such a buffer strip, herbicide must not
25 be applied to or be allowed to inadvertently affect the
26 buffer area. During the application of herbicide to the
27 gravel pad, care should be taken to minimize inadvertent
28 spray drift. Spray drift is a term describing the movement of
29 spray from the area of application to an unintended area
30 while the spray is suspended in the air. Wind speed is a key
31 component in spray drift; herbicide should be applied when
32 wind speeds are not above 2-10 mph. Note that as wind speed
33 increases, spray droplet size should be increased to create a
34 heavier droplet that is less susceptible to crosswinds.

35 Proper configuration of sprayers can greatly reduce drift.
36 One method of reducing drift is to lower the spray nozzle
37 height, allowing the droplets to reach the target surface
38 more quickly. Also, drift can be lessened by reducing the
39 pressure of the sprayer; this will result in larger droplet
40 sizes that spend less time in suspension. The type of sprayer
41 nozzle plays a large role in spray drift; specific "drift-
42 reducing" nozzles will aid in reducing spray drift.

10 June 2014

1 Spraying only during proper atmospheric conditions (ideal
2 conditions are dry, windless days) is also vital to proper
3 herbicide application.

4



5



6

7 **Figure C-5. Herbicide-treated gravel pad (unaltered view on top). The altered**
8 **bottom image shows bare soil in purple, with vegetation death shown in red**
9 **(ERDC-CERL).**

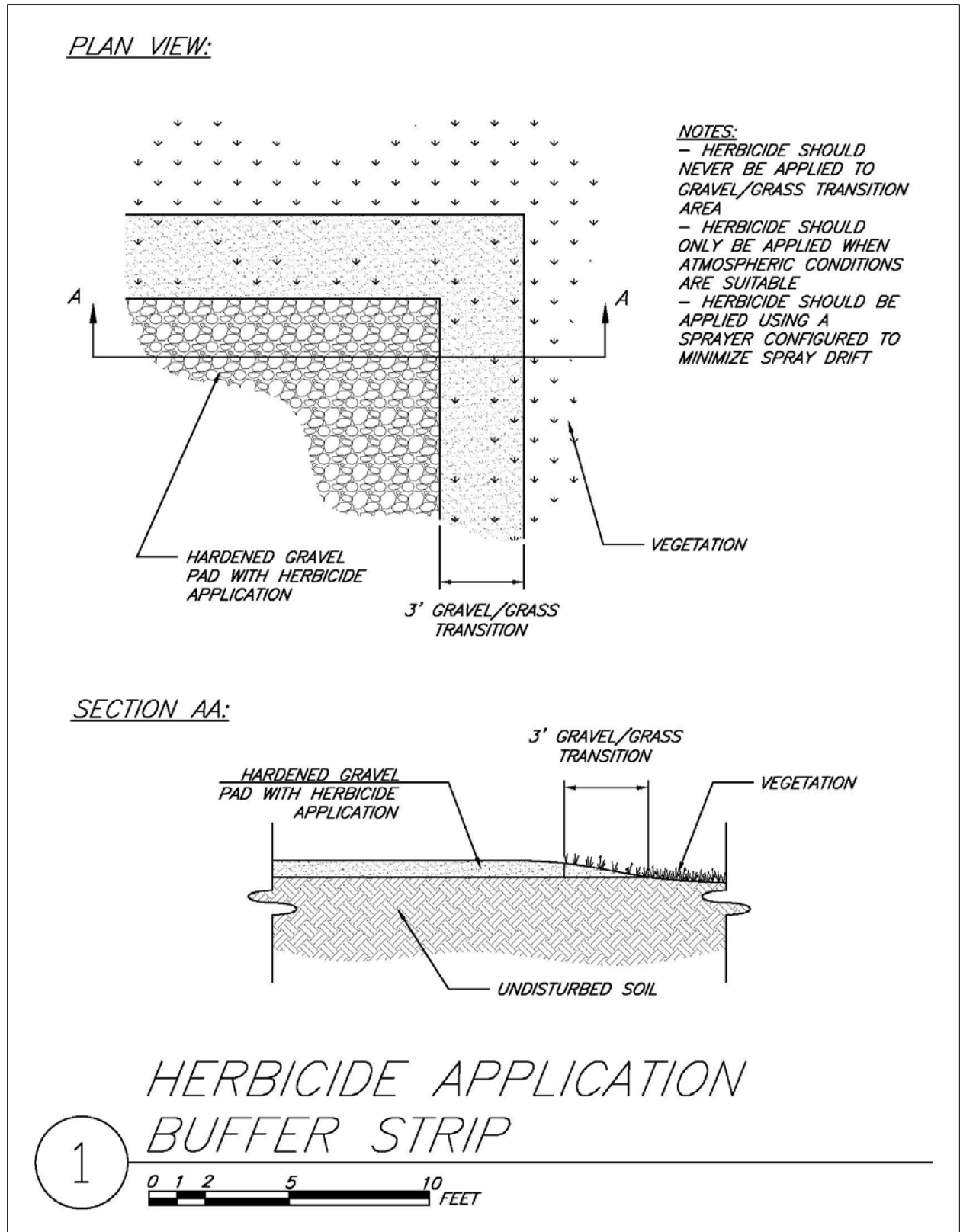

1
2 Figure C-6. Design for a buffer strip as solution for herbicide application
3 drift (ERDC-CERL).

1 **Permanent UTA Examples**

2 *Permanent UTA: Problem Area #1*

3 **Problem: Rill formation**

4 The two sets of pictures in Figure C-7 show rill formation
5 from water coming off impervious surface areas. The top image
6 set, showing the lower side of an old agricultural terrace in
7 a grassy area, identifies the terrace with a yellow dotted
8 line, and areas in red illustrate rill formation. In the
9 bottom set of pictures, the rill originates from an area
10 where machinery and equipment were stored for an extended
11 period of time. The equipment-covered area acts as a hardened
12 surface that does not allow water to effectively infiltrate
13 the soil (highlighted in blue). The runoff from this
14 "hardened" area then becomes concentrated in areas that show
15 up in the images as eroded areas. As shown in all the
16 pictures, a lack of vegetative cover in the areas of
17 increased water flow leaves the soil susceptible to erosion.



18

19

20 **Figure C-7. Two examples of rill formation shown by red areas in two altered**
21 **photos on right. Yellow line in upper right photo indicates an old**
22 **agricultural terrace and blue area in lower right photo indicates a hardened**
23 **area; both are causes of rill formation (ERDC-CERL).**

1 **Solution: Reshaping, reseeding, cover**

2 In order to prevent further loss of soil, the rill should be
3 shaped into a parabolic channel, seeded to reestablish
4 vegetation, and protected by using a rolled erosion-control
5 product to protect the soil from concentrated water flow
6 while vegetation is being reestablished (Figure C-8). The
7 parabolic shape of the ditch can be achieved by tilling the
8 area along the rill and grading to shape. The tillage should
9 be done in a manner that creates a smooth but loose surface.
10 The freshly tilled soil should then be seeded, and a rolled
11 erosion-control product installed immediately.

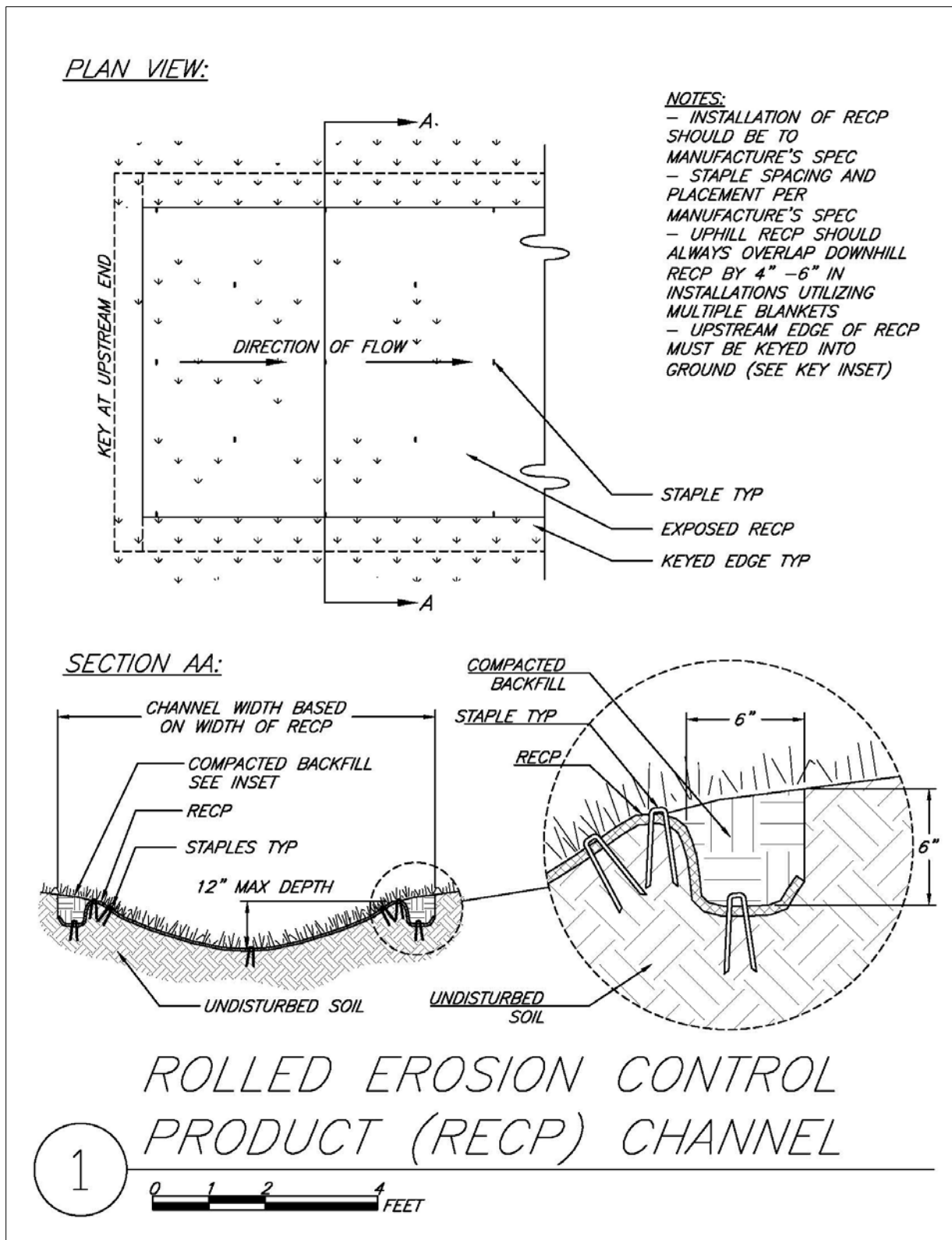

1
2
3

Figure C-8. Rolled erosion-control product channel design as part of solution to rill formation (ERDC-CERL).

1 *Permanent UTA: Problem Area #2*

2 **Problem: Foundation erosion**

3 The picture pair in Figure C-9 illustrates soil loss due to
4 erosion at the base of a building foundation (impacted areas
5 highlighted in blue). Here, the three factors leading to
6 erosion occurring along the side of the structure are: (1)
7 concentrated water flow due to water running off the roof and
8 eroding the previously vegetated ground along the roof's drip
9 line (which falls right at the foundation's edge); (2) the
10 steep slopes along the side of the building; and (3)
11 potential herbicide and/or mowing damage along the
12 foundation. Once vegetation loss occurs within the roofline
13 drip zone, erosion is quick to follow and could be considered
14 unavoidable if preventive measures are not utilized.

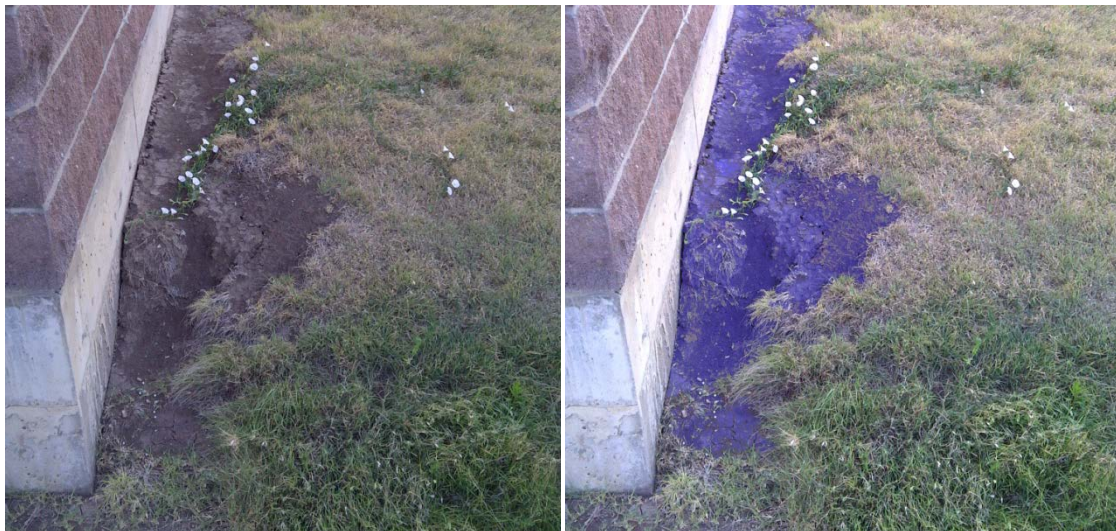

15
16 **Figure C-9. Building erosion from roof runoff, steep slopes, and mowing or**
17 **herbicide application near foundation. Impacted area is highlighted in blue**
18 **in photo on right (ERDC-CERL).**

19 **Solution: Gutter system, infiltration trench**

20 The best, most permanent method of preventing the erosion
21 shown above would be the addition of a gutter to the building
22 to convey water from the roof away from the foundation.
23 However, the addition of a gutter without follow-on measures
24 at the downspout outlet will lead to high flow concentration
25 at that location, resulting in another instance of erosion.
26 In order to protect the corner of the foundation and soil
27 around the downspout, an infiltration trench leading away
28 from the building should be installed to prevent localized
29 erosion by conveying water away from the building and

10 June 2014

1 dissipating the water's energy before it has the chance to
2 erode the soil.

3 The trench's construction should be 12-18 in. deep and slope
4 away from the building at least 5 ft in the downslope
5 direction. Trench dimensions may change based on the size of
6 the building and expected rainfall for the region. The
7 trench, once it is excavated to the site and environmental
8 requirements, should be lined with a permeable geotextile and
9 filled with 2-in. washed round (not crushed) aggregate.

10 During precipitation events, the infiltration trench will
11 receive water from the downspout. Water will flow between and
12 fill up the void space between the aggregate in the trench.
13 Adding an infiltration trench has several advantages over a
14 typical gutter-only system. First, the trench is able to
15 store water until it is able to infiltrate into the
16 surrounding soil. This water detention and storage will
17 result in higher surrounding soil moisture levels that will
18 in turn support vegetation. Also, the aggregate's mass will
19 absorb the energy contained in the flowing water, lessening
20 its erosive potential on the soil and eliminating the
21 concentrated water flows typical of gutter downspouts.
22 Furthermore, the design does not create any above-ground
23 obstructions that could otherwise be detrimental to the
24 required military training functionality of the building.

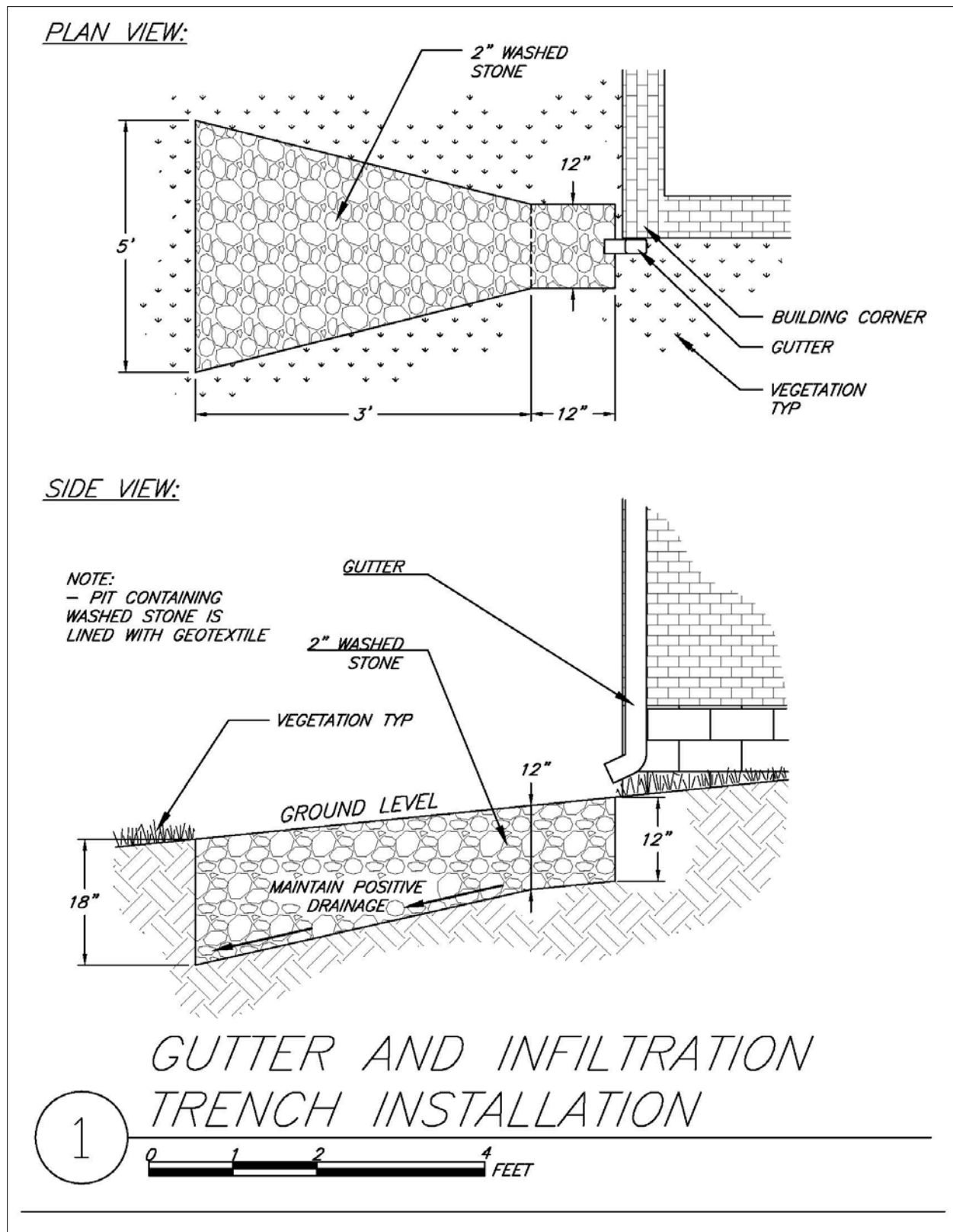

1
2
3

Figure C-10. Plan for gutter and infiltration trench as solution for foundation erosion (ERDC-CERL).

1 *Permanent UTA Problem Area #3*

2 **Problem: Gully formation**

3 Similar to the issue illustrated in Permanent UTA Problem
4 Area #1, the paired images in Figure C-11 show gully
5 formation (red area). According to an informed site
6 maintenance worker, the ditch was cut in an effort to direct
7 water away from the gravel road surface because the road
8 surface was being washed away and the edges were becoming
9 undercut. However, the ditch was subsequently left bare of
10 vegetation or any other soil protective measure. The high
11 concentrations of water flow off such a large contributing
12 area caused further deepening of the ditch into the gully
13 shown in Figure C-11. The resulting gully is large and steep
14 enough that the vegetation cannot be easily managed. The
15 result is a large population of broadleaf vegetation (blue
16 area in Figure C-11). The broadleaf vegetation does not
17 provide adequate protection at the soil surface to prevent
18 erosion. If this gully continues to expand, it will result in
19 greater soil loss, decreased water quality, and increased
20 cost of repair. Note that repair eventually will be
21 unavoidable due to safety concerns.



22
23 **Figure C-11. Gully formation is shown in red on altered photo at right,**
24 **and resulting large population of broadleaf vegetation**
25 **is shown in blue (ERDC-CERL).**

1 **Solution: Redesign gully to parabolic ditch**

2 The gully shown in Figure C-11 should be redesigned to a
3 parabolic ditch with a rock center. The design solution
4 recognizes that vegetation will not be easily established in
5 a ditch that is meant to carry such a large amount of water
6 volume at a higher velocity from a large contributing area.
7 The rock center will protect the soil at the bottom of the
8 ditch, in addition to slowing the water's velocity. This
9 slower velocity will reduce erosion potential within the
10 ditch and where it ends. Also, the sides of the ditch will be
11 reshaped to be longer, less steep, and better able to support
12 vegetation, giving further protection from erosion. While
13 vegetation is being established, the ditch sides should be
14 lined with a rolled erosion-control product to protect the
15 bare soil. Alternatively, the rock center could be replaced
16 with a series of riprap check dams. However, check dams
17 increase maintenance costs as they need to be cleaned out
18 periodically to remain effective.

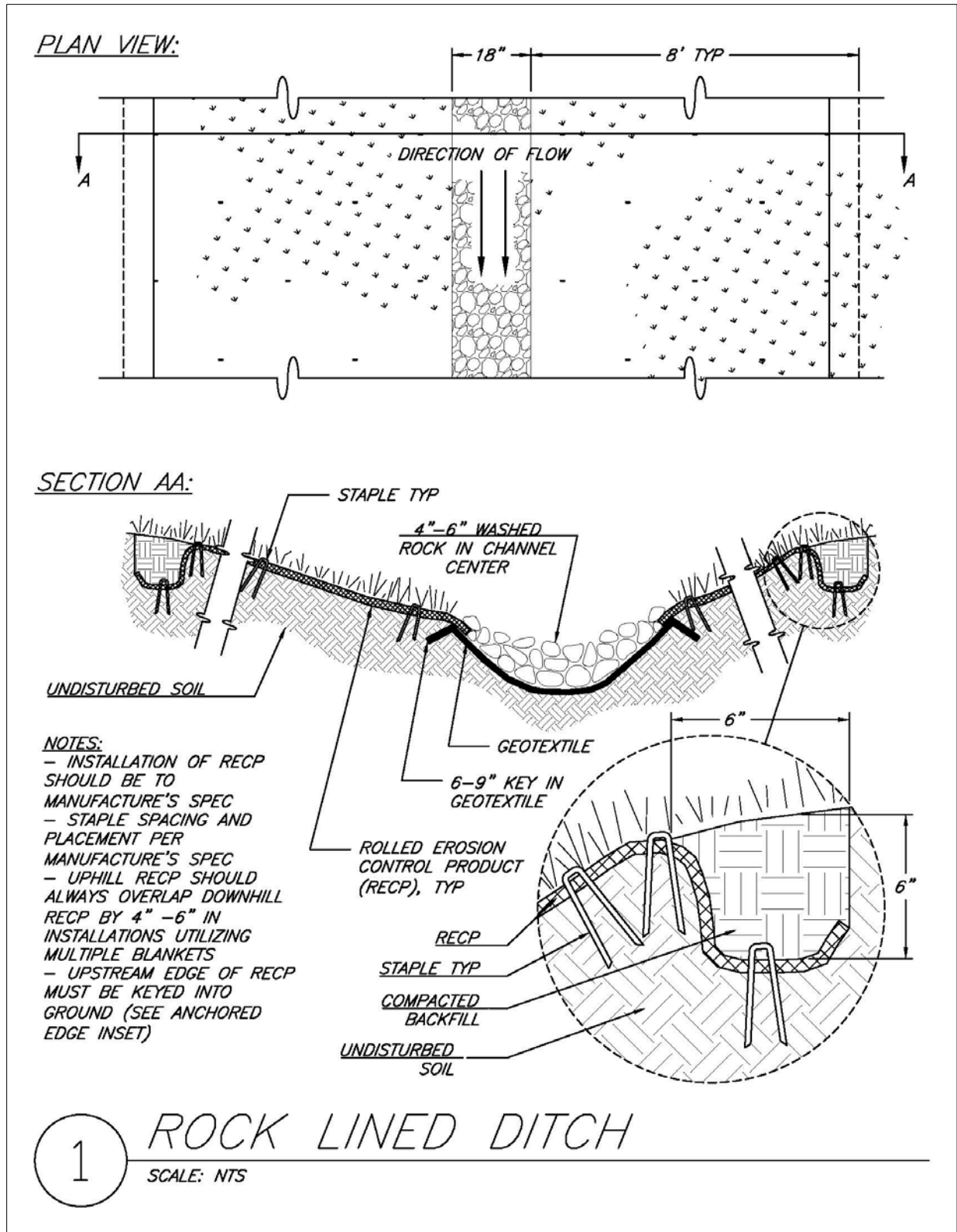

1
2 Figure C-12. Rock-lined ditch solution to address problem of gully formation
3 (ERDC-CERL).

1 *Permanent UTA Problem Area #4*

2 **Problem: Vehicle crossing shallow ditch**

3 Figure C-13 shows a heavily-trafficked vehicle crossing
4 through a wide but shallow roadside ditch area. A drop zone
5 exists farther in field (blue area in Figure C-13), which is
6 assumed to be the navigational aim of the vehicles crossing
7 the roadside ditch. Although the ditch currently shows light
8 erosion at the crossing, it has obviously been impacted by
9 the vehicle traffic and is an area of concern. Concerns
10 include the high percentage of bare soil (shown in red),
11 known locally heavy precipitation events and resulting high
12 water flows, incurred soil compaction, and potential of
13 rutting deformation during wet soil conditions.

14



15

16 **Figure C-13. Top photo shows vehicle crossing a shallow ditch (foreground) to**
17 **reach a drop zone (background). In altered bottom photo of same scene, bare**
18 **soil is indicated in red and drop zone is shown in blue (ERDC-CERL).**

10 June 2014

1 Solution: Low-water crossing

2 With the amount of heavy vehicles and other traffic crossing
3 the ditch at this location, it would be difficult to
4 establish and maintain vegetation in this area. The addition
5 of a low-water crossing would greatly improve the soil
6 stability and site sustainability. There are many materials
7 and strategies suitable for constructing low-water crossings,
8 all with similar functional abilities. Low-water crossings
9 protect the underlying soil from erosion of concentrated
10 water flows, while creating a stable surface for vehicles to
11 cross the ditch in a designated area.

12 A stabilized crossing can be constructed in several ways, and
13 the materials used should be based on several factors: cost
14 of construction; availability, frequency, and duration of
15 use; and anticipated type of vehicle traffic. Two design
16 solutions will be presented here.

17 The first design implements the use of prefabricated cable
18 concrete, which requires reduced labor costs at the time of
19 installation (Figure C-14). Cable concrete creates a durable
20 crossing that is passable for and compatible with most
21 wheeled and tracked vehicles.

22 However, alternative materials can be used very successfully
23 to construct a low-water crossing. Riprap used in conjunction
24 with an underlying geotextile can be effectively used as a
25 low-water crossing but will limit vehicle use to off-road
26 vehicles. Also, riprap crossings are less permanent and lead
27 to higher maintenance requirements.

28 The second design solution utilizes the alternative material
29 of worn tank tracks. As shown by the top photo in Figure
30 C-15, tank tracks are installed in place of cable concrete.
31 The tank tracks are also compatible for use by most wheeled
32 and tracked vehicles, with additional advantages of
33 potentially lower cost and higher availability. The tank
34 track design has also proven to be more durable than other
35 commercial solutions, remaining in place during heavy
36 precipitation events or high water flows, where other low
37 water crossings wash out and require repair (bottom photo in
38 Figure C-15). This durability is due to the weight of tracks.
39 This second design solution shows the proper preparation of
40 tank tracks when used in place of cable concrete in a
41 stabilized dry ditch crossing (Figure C-16).

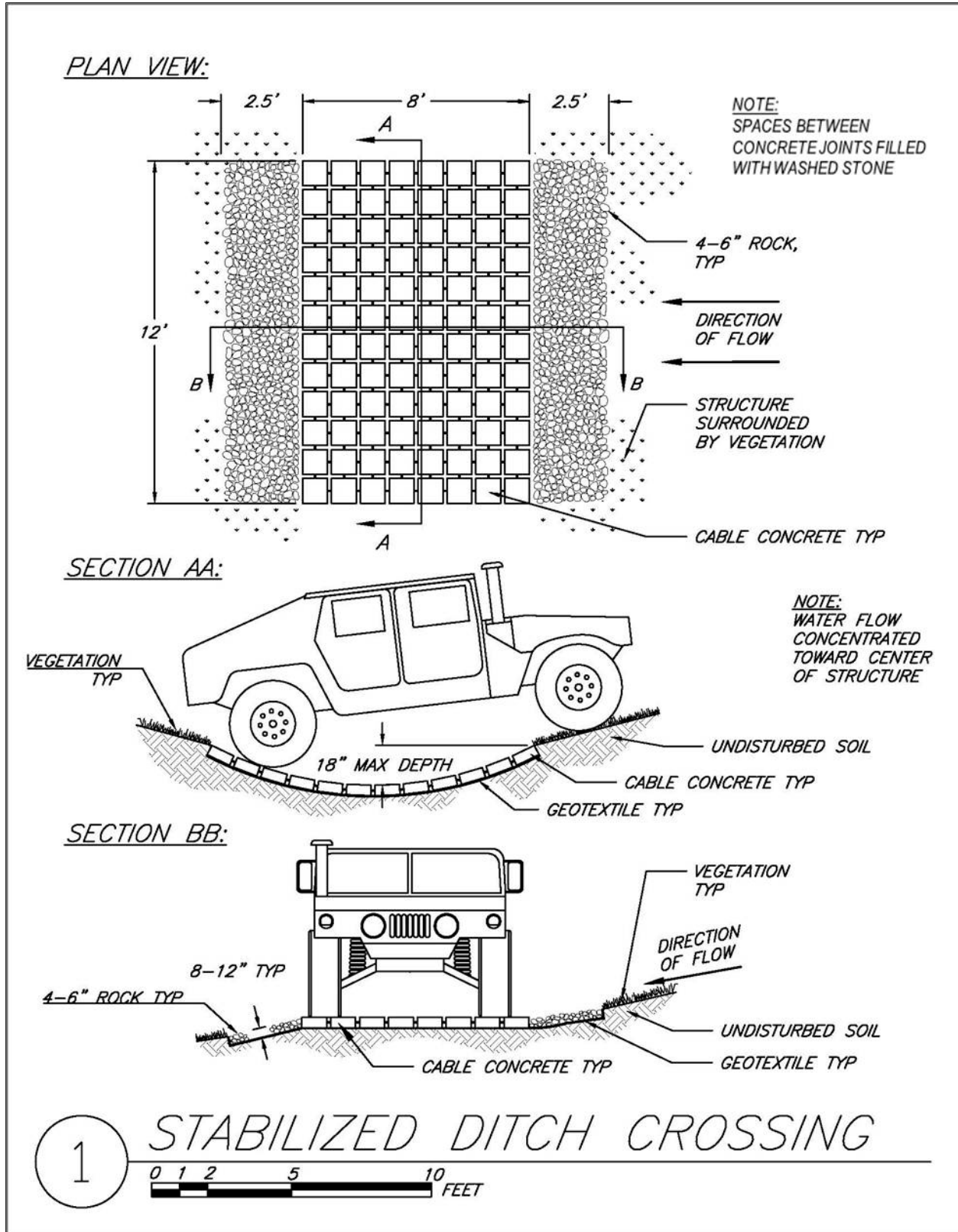

1
 2
 3

Figure C-14. Design for cable concrete used as a solution to stabilize ditch crossing (ERDC-CERL).



1



2

3

4

5

6

7

8

Figure C-15. Low-water crossings installed with used tank tracks as solution to erosion from vehicles crossing shallow ditches (top photo). The tank track design proved more durable than other commercial solutions, remaining in place during heavy precipitation events or high water flows (bottom photo) (ERDC-CERL).

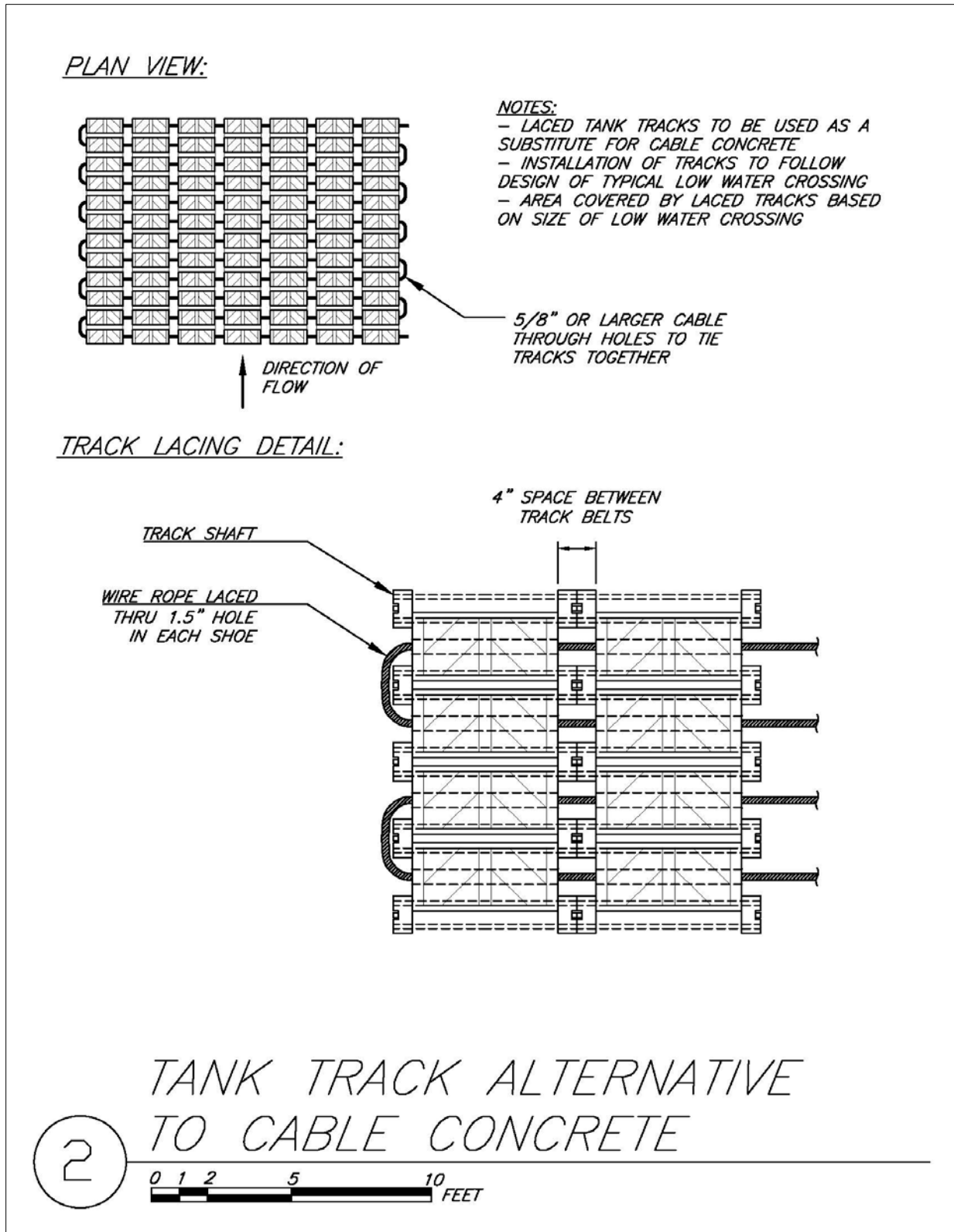

1
2
3
4

Figure C-16. Design solution when installing tank track as an alternative to cable concrete to solve soil erosion from vehicle traffic crossing a shallow ditch (ERDC-CERL).

1 *Permanent UTA Problem Area #5*

2 **Problem: Road erosion from high-volume water**

3 Figure C-17 illustrates a road being washed away due to high
4 volumes of water flow. The driveway entering the road from
5 the left concentrates water flow by obstructing the natural
6 flow down the side of the road and thus eroding the surface
7 of the road. The road shows signs of erosion where all the
8 gravel fines have been removed (blue area). Also, a gully has
9 formed at the point of concentrated flow (red area) because
10 there are no protective measures in place to convey water
11 away from the road.



12
13 **Figure C-17. Erosion caused from high-volume water flow from driveway**
14 **entering a roadway. Altered photo on right shows resulting erosion of gravel**
15 **fines (blue area) and formation of a gully (red area) (ERDC-CERL).**

16 **Solution: Adding ditches and culverts**

17 This scenario could be greatly improved by adding a ditch
18 along both sides of the road, as well as culverts underneath
19 gravel driveways connecting to the main road and thus
20 crossing the proposed ditch (Figure C-18). The ditches and
21 culverts would need to be designed for the high volume of

10 June 2014

1 water coming from the traffic surfaces. This will also lessen
2 the sheet erosion that has been occurring across the surface
3 of the road. A properly constructed ditch will prevent the
4 undermining of the road by protecting the aggregate,
5 geotextile, and soil base that supports the road.
6 Installation of the culverts will ensure that water is
7 properly conveyed through the center of the ditch, and
8 maintain a continuous water channel down the length of the
9 road. This will prevent the water from ponding in the ditch
10 upstream of the driveway; in a heavy precipitation event such
11 ponding can cause the upstream corner of the driveway and
12 roadside to become scoured out during periods of high-flow
13 while the downstream side becomes washed over with displaced
14 sediment and aggregate. Standing water after a precipitation
15 event is detrimental to vegetation that is protecting the
16 soil within the ditch.

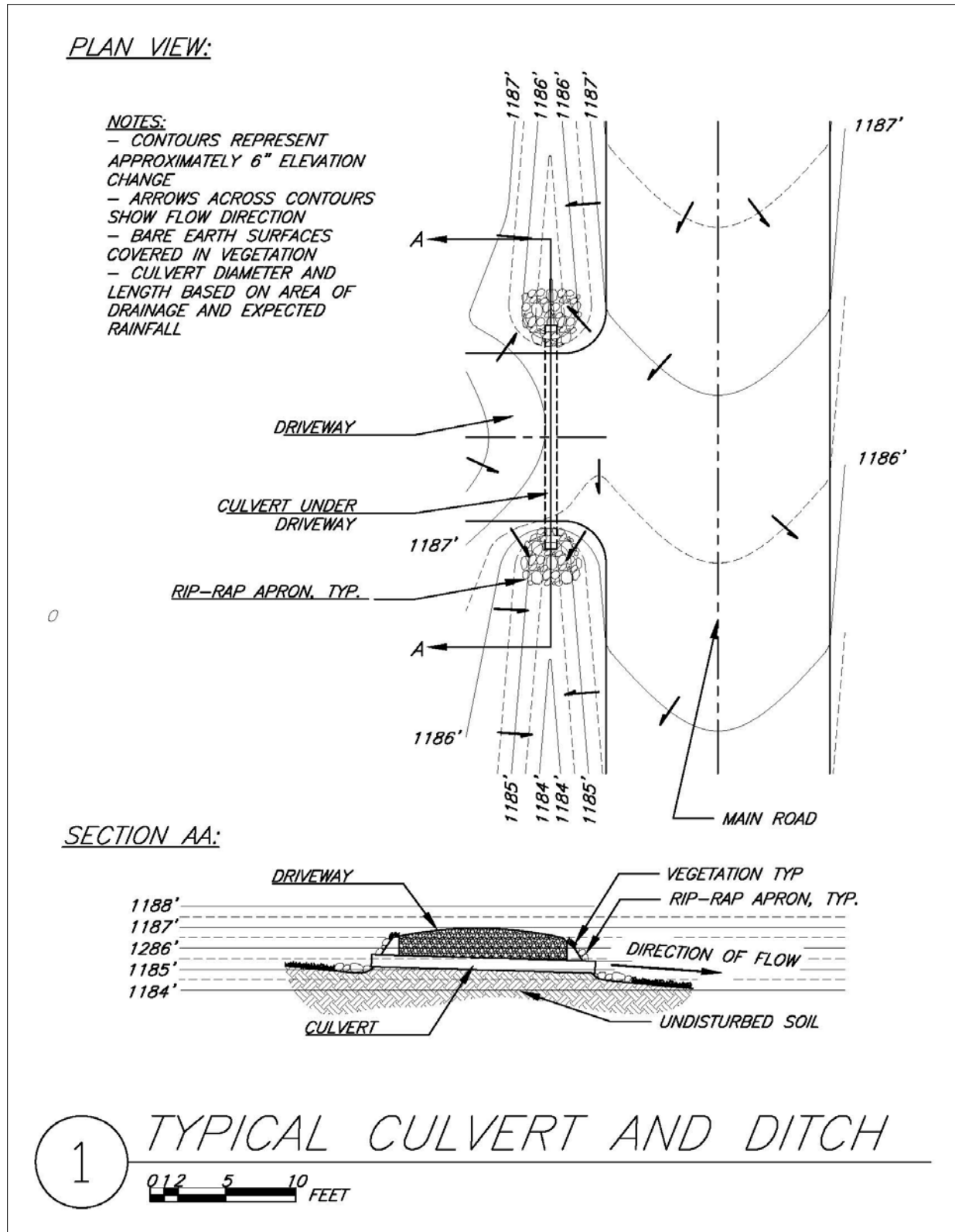

1
 2 Figure C-18. Culvert and ditch design as solution for road erosion from high-
 3 volume water flow (ERDC-CERL).

**APPENDIX D:
DISCUSSION AND LESSONS LEARNED**

Design Differences in UTAs

The Army's need to provide soldiers with urban combat training environments has led to the construction of UTAs. Two types of UTAs have emerged – temporary and permanent. The type of UTA is dictated by the manner in which funds can be provided and utilized for site development on Army installations. The two types of UTAs each have unique design concepts and maintenance schedules as well as differences in fund provenance and availability. Each type of UTA is easily identified by its construction style, complexity, and maintenance regularity.

The combined LID technologies and in-field BMP strategies suggested in this PWTB are designed with the differences in temporary and permanent UTAs in mind. Each type of UTA requires design solutions, and each has a different life span, implementation costs, and maintenance level. The design solutions for each type of UTA meet the requirements of the Army's training mission, without significant modifications that would impact the on-site training environment.

Maintenance Requirements

All design solutions in this PWTB were chosen with the cost of maintenance in mind. Designs suggested for the temporary UTA add little or no maintenance to the site's current maintenance schedule, thus requiring minimal costs for upkeep after installation and implementation. By contrast, design solutions suggested for the permanent site may have some added maintenance requirements. For example, regular mowing is required with designs using vegetation for soil stabilization. The mowing can reduce sheet erosion potential by preventing the establishment of tall broadleaf plants. These added maintenance requirements for the permanent UTA sites are minimal and not likely to exceed the cost of site repairs or safety incidents that could result from the erosion or repair issues identified within this document.

Lessons Learned

The following lessons were learned after completing this study:

1. Data for the hydrologic analysis is easily obtained via the Web and/or from installation-level high-resolution LiDAR databases; this means there is minimal need for site visits to collect data.
2. ArcGIS can be used to accurately identify areas of hydrological importance on both types of UTAs.
3. Many LID technologies and BMP strategies are available to reduce the types of soil erosion occurring across UTAs.
4. Designs for reducing erosion on UTAs are site-specific due to such factors as environmental conditions, soils, design influence on runoff rates, and soldier utilization. Thus, designs should be done on a case-by-case basis.
5. LID technologies and BMP strategies can be very cost efficient, especially when their long-term effectiveness and sustainability is considered. Even with added maintenance responsibilities associated with such modifications, resulting costs remain cheaper than non-modified UTAs after erosion damage has occurred and repairs are carried out.
6. Using LID technologies and BMP strategies creates a safer and more stable field training environment by preventing gullies and other erosion-related safety hazards.
7. The designs suggested promote infrastructure stability by ensuring that related buildings, roads, and ditches will continue to support training throughout the life span of each UTA.

APPENDIX E: ABBREVIATIONS

Term	Spellout
3D	three-dimensional
AAR	After-Action Review
AR	Army Regulation
BMP	best management practice
CECW	Directorate of Civil Works, United States Army Corps of Engineers
CEMP-CE	Directorate of Military Programs, United States Army Corps of Engineers
CERL	Construction Engineering Research Laboratory
DoD	Department of Defense
EISA	Energy Independence and Security Act
EO	Executive Order
ERDC	Engineer Research and Development Center
GPS	global positioning system
HQUSACE	Headquarters, United States Army Corps of Engineers
LID	low impact development
LiDAR	light detection and ranging
MOUT	Military Operation in Urban Terrain
NRCS	Natural Resources Conservation Service
POC	point of contact
PWTB	Public Works Technical Bulletin
RTK	real-time kinematic
SSPP	Strategic Sustainability Performance Plan
TC	Training Circular
USACE	United States Army Corps of Engineers

PWTB 200-1-141
10 June 2014

Term	Spellout
U.S.C.	United States Code
UTA	urban training area

(This publication may be reproduced.)