

TM 5-686

TECHNICAL MANUAL

**POWER TRANSFORMER MAINTENANCE
AND ACCEPTANCE TESTING**

APPROVED FOR PUBLIC RELEASE: DISTRIBUTION IS UNLIMITED

HEADQUARTERS, DEPARTMENT OF THE ARMY

16 NOVEMBER 1998

REPRODUCTION AUTHORIZATION/RESTRICTIONS

This manual has been prepared by or for the Government and, except to the extent indicated below, is public property and not subject to copyright.

Reprint or republication of this manual should include a credit substantially as follows: "Department of the Army TM 5-686, Power Transformer Maintenance and Acceptance Testing, *16 November 1998.*"

APPROVED FOR PUBLIC RELEASE; DISTRIBUTION IS UNLIMITED

Power Transformer Maintenance and Acceptance Testing

		<i>Paragraph</i>	<i>Page</i>
CHAPTER 1.	INTRODUCTION/SAFETY		
	Purpose	1-1	1-1
	Scope	1-2	1-1
	References	1-3	1-1
	Maintenance and testing	1-4	1-2
	Safety	1-5	1-2
	Nameplate data	1-6	1-3
CHAPTER 2.	CONSTRUCTION/THEORY		
	Transformer applications	2-1	2-1
	Magnetic flux	2-2	2-2
	Winding, current and voltage ratios	2-3	2-2
	Core construction	2-4	2-3
	Core form construction	2-5	2-4
	Shell form construction	2-6	2-4
CHAPTER 3.	TRANSFORMER CONNECTIONS AND TAPS		
	Tapped primaries and secondaries	3-1	3-1
	Polarity	3-2	3-1
	Autotransformers	3-3	3-2
	Single and multi-phase relationships	3-4	3-2
	Delta-wye and wye-delta displacements	3-5	3-6
CHAPTER 4.	COOLING/CONSTRUCTION CLASSIFICATIONS		
	Classifications	4-1	4-1
	Dry-type transformers	4-2	4-1
	Liquid-filled transformers	4-3	4-1
	Tank construction	4-4	4-2
	Free breathing tanks	4-5	4-2
	Conservator tanks	4-6	4-2
	Gas-oil sealed tanks	4-7	4-3
	Automatic inert gas sealed tanks	4-8	4-3
	Sealed tank type	4-9	4-4
CHAPTER 5.	INSULATING FLUIDS		
	Oil	5-1	5-1
	Oil testing	5-2	5-1
	Dissolved gas in oil analysis	5-3	5-2
	Transformer oil sampling	5-4	5-4
	Synthetics and other insulating fluids	5-5	5-5
CHAPTER 6.	INITIAL ACCEPTANCE INSPECTION/TESTING		
	Acceptance	6-1	6-1
	Pre-arrival preparations	6-2	6-1
	Receiving and inspection	6-3	6-2

	<i>Paragraph</i>	<i>Page</i>
Moving and storage	6-4	6-2
Internal inspection	6-5	6-3
Testing for leaks	6-6	6-4
Vacuum filling	6-7	6-4
CHAPTER 7. TRANSFORMER TESTING		
Test data	7-1	7-1
Direct current testing	7-2	7-1
Alternating current testing	7-3	7-4
CHAPTER 8. TRANSFORMER AUXILIARY EQUIPMENT		
Auxiliaries	8-1	8-1
Bushings	8-2	8-1
Pressure relief devices	8-3	8-1
Pressure gauges	8-4	8-3
Temperature gauges	8-5	8-3
Tap changers	8-6	8-4
Lightning (surge) arresters	8-7	8-6
CHAPTER 9. COMPREHENSIVE MAINTENANCE/TESTING PROGRAM		
Transformer maintenance	9-1	9-1
Maintenance and testing program	9-2	9-1
Documentation	9-3	9-2
Scheduling	9-4	9-2
CHAPTER 10. STATUS OF TRANSFORMER MONITORING AND DIAGNOSTICS		
Introduction	10-1	10-1
Transformer monitoring	10-2	10-1
Transformer diagnostics	10-3	10-3
Conclusions	10-4	10-3
APPENDIX A REFERENCES		A-1
GLOSSARY		G-1

List of Figures

<i>Figure</i>	<i>Title</i>	<i>Page</i>
1-1	Typical power transformer	1-1
2-1	Distribution system schematic	2-1
2-2	Transformer flux lines	2-2
2-3	Transformer equal turns ratio	2-3
2-4	Transformer 10:1 turns ratio	2-3
2-5	Transformer 1:10 turns ratio	2-3
2-6	Transformer core construction	2-4
2-7	Transformer shell construction	2-5
3-1	Transformer taps	3-1
3-2	Single Phase transformer secondary winding arrangements	3-2
3-3	Physical transformer polarity	3-2
3-4	Diagrammatic transformer polarity	3-3
3-5	Transformer subtractive polarity test	3-3
3-6	Transformer additive polarity test	3-4
3-7	Autotransformer	3-4
3-8	Sine wave	3-5
3-9	Three-phase sine waves	3-5
3-10	3 phase phasor diagram	3-5
3-11	Delta-delta and wye-wye transformer configurations	3-5
3-12	Wye-delta and delta-wye transformer configurations	3-6
3-13	Transformer lead markings	3-7
3-14	Wye delta transformer nameplate	3-7
4-1	Conservator tank transformers	4-3
4-2	Gas-oil sealed transformers	4-3
4-3	Automatic inert gas sealed transformers	4-3
4-4	Sealed tank transformers	4-4
6-1	Transformer tank vacuum filling	6-5
7-1	Transformer maintenance test diagram	7-3

List of Figures (continued)

<i>Figure</i>	<i>Title</i>	<i>Page</i>
7-2	Transformer acceptance test diagram	7-3
7-3	Winding losses in a transformer with uncontaminated dielectric	7-5
7-4	Winding losses in a transformer with contaminated dielectric	7-5
7-5	Voltmeter-ammeter-wattmeter method of measuring insulation power factor	7-6
7-6	"Hot collar" bushing power factor test	7-6
8-1	Transformer porcelain and oil filled bushings	8-2
8-2	Mechanical pressure-relief device	8-3
8-3	Sudden pressure relay	8-4
8-4	Temperature gauge	8-5
8-5	Dial type temperature gauge	8-5
8-6	Schematic diagram of transformer tap-changer	8-5
8-7	Lightning arresters	8-6
10-1	Typical failure distribution for substation transformers	10-1

List of Tables

<i>Table</i>	<i>Title</i>	<i>Page</i>
5-1	Insulating fluids: suggested test values	5-3
5-2	Dissolved gas in oil analysis	5-4
5-3	Troubleshooting transformers with detected gases	5-5
10-1	Transformer gases and corresponding sources	10-2

CHAPTER 1

INTRODUCTION/SAFETY

1-1. Purpose

This manual contains a generalized overview of the fundamentals of transformer theory and operation. The transformer is one of the most reliable pieces of electrical distribution equipment (see figure 1-1). It has no moving parts, requires minimal maintenance, and is capable of withstanding overloads, surges, faults, and physical abuse that may damage or destroy other items in the circuit. Often, the electrical event that burns up a motor, opens a circuit breaker, or blows a fuse has a subtle effect on the transformer. Although the transformer may continue to operate as before, repeat occurrences of such damaging electrical events, or lack of even minimal maintenance can greatly accelerate the eventual failure of the transformer. The fact that a transformer continues to operate satisfactorily in spite of neglect and abuse is a testament to its durability. However, this durability is no excuse for not providing the proper care. Most of the effects of aging, faults, or abuse can be detected and

corrected by a comprehensive maintenance, inspection, and testing program.

1-2. Scope

Substation transformers can range from the size of a garbage can to the size of a small house; they can be equipped with a wide array of gauges, bushings, and other types of auxiliary equipment. The basic operating concepts, however, are common to all transformers. An understanding of these basic concepts, along with the application of common sense maintenance practices that apply to other technical fields, will provide the basis for a comprehensive program of inspections, maintenance, and testing. These activities will increase the transformer's service life and help to make the transformer's operation both safe and trouble-free.

1-3. References

Appendix A contains a list of references used in this manual.

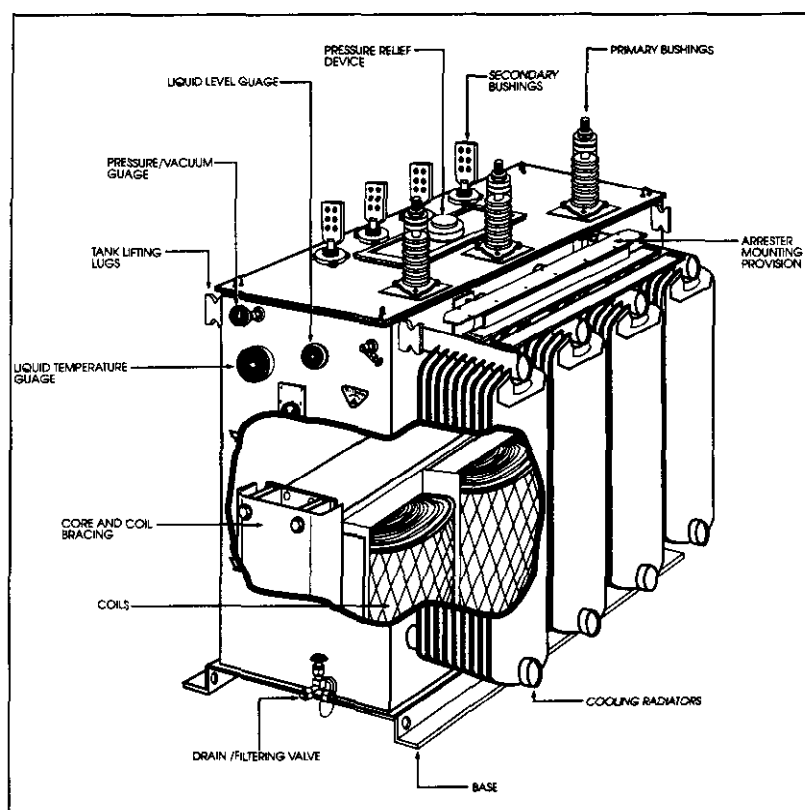

Figure 1-1. Typical power transformer.

1-4. Maintenance and testing

Heat and contamination are the two greatest enemies to the transformer's operation. Heat will break down the solid insulation and accelerate the chemical reactions that take place when the oil is contaminated. All transformers require a cooling method and it is important to ensure that the transformer has proper cooling. Proper cooling usually involves cleaning the cooling surfaces, maximizing ventilation, and monitoring loads to ensure the transformer is not producing excess heat.

a. Contamination is detrimental to the transformer, both inside and out. The importance of basic cleanliness and general housekeeping becomes evident when long-term service life is considered. Dirt build up and grease deposits severely limit the cooling abilities of radiators and tank surfaces. Terminal and insulation surfaces are especially susceptible to dirt and grease build up. Such buildup will usually affect test results. The transformer's general condition should be noted during any activity, and every effort should be made to maintain its integrity during all operations.

b. The oil in the transformer should be kept as pure as possible. Dirt and moisture will start chemical reactions in the oil that lower both its electrical strength and its cooling capability. Contamination should be the primary concern any time the transformer must be opened. Most transformer oil is contaminated to some degree before it leaves the refinery. It is important to determine how contaminated the oil is and how fast it is degenerating. Determining the degree of contamination is accomplished by sampling and analyzing the oil on a regular basis.

c. Although maintenance and work practices are designed to extend the transformer's life, it is inevitable that the transformer will eventually deteriorate to the point that it fails or must be replaced. Transformer testing allows this aging process to be quantified and tracked, to help predict replacement intervals and avoid failures. Historical test data is valuable for determining damage to the transformer after a fault or failure has occurred elsewhere in the circuit. By comparing test data taken after the fault to previous test data, damage to the transformer can be determined.

1-5. Safety

Safety is of primary concern when working around a transformer. The substation transformer is usually the highest voltage item in a facility's electrical distribution system. The higher voltages found at the transformer deserve the respect and complete attention of anyone working in the area. A 13.8 kV system will arc to ground over 2 to 3 in. However, to extinguish that same arc will require a separation of 18 in. Therefore, working around energized conductors is not recommended for anyone but the qualified professional. The best way to ensure safety when working around high voltage apparatus is to make absolutely certain that it is de-energized.

a. Although inspections and sampling can usually be performed while the transformer is in service, all other service and testing functions will require that the transformer is de-energized and locked out. This means that a thorough understanding of the transformer's circuit and the disconnecting methods should be reviewed before any work is performed.

b. A properly installed transformer will usually have a means for disconnecting both the primary and the secondary sides; ensure that they are opened before any work is performed. Both disconnects should be opened because it is possible for generator or induced power to backfeed into the secondary and step up into the primary. After verifying that the circuit is de-energized at the source, the area where the work is to be performed should be checked for voltage with a "hot stick" or some other voltage indicating device.

c. It is also important to ensure that the circuit stays de-energized until the work is completed. This is especially important when the work area is not in plain view of the disconnect. Red or orange lock-out tags should be applied to all breakers and disconnects that will be opened for a service procedure. The tags should be highly visible, and as many people as possible should be made aware of their presence before the work begins.

d. Some switches are equipped with physical locking devices (a hasp or latch). This is the best method for locking out a switch. The person performing the work should keep the key at all times, and tags should still be applied in case other keys exist.

e. After verifying that all circuits are de-energized, grounds should be connected between all items that could have a different potential. This means that all conductors, hoses, ladders and other equipment should be grounded to the tank, and that the tank's connection to ground should be verified before beginning any work on the transformer. Static charges can be created by many maintenance activities, including cleaning and filtering. The transformer's inherent ability to step up voltages and currents can create lethal quantities of electricity.

f. The inductive capabilities of the transformer should also be considered when working on a de-energized unit that is close to other conductors or devices that are energized. A de-energized transformer can be affected by these energized items, and dangerous currents or voltages can be induced in the adjacent windings.

g. Most electrical measurements require the application of a potential, and these potentials can be stored, multiplied, and discharged at the wrong time if the proper precautions are not taken. Care should be taken during the tests to ensure that no one comes in contact with the transformer while it is being tested. Set up safety barriers, or appoint safety personnel to secure remote test areas. After a test is completed, grounds should be left on the tested item for twice the duration of the test, preferably longer.

h. Once the operation of the transformer is understood, especially its inherent ability to multiply voltages and currents, then safety practices can be applied and modified for the type of operation or test that is being performed. It is also recommended that anyone working on transformers receive regular training in basic first aid, CPR, and resuscitation.

1-6. Nameplate data

The transformer nameplate contains most of the important information that will be needed in the field. The nameplate should never be removed from the transformer and should always be kept clean and legible. Although other information can be provided, industry standards require that the following information be displayed on the nameplate of all power transformers:

a. Serial number. The serial number is required any time the manufacturer must be contacted for information or parts. It should be recorded on all transformer inspections and tests.

b. Class. The class, as discussed in paragraph 4-1, will indicate the transformer's cooling requirements and increased load capability.

c. The kVA rating. The kVA rating, as opposed to the power output, is a true indication of the current carrying capacity of the transformer. kVA ratings for the various cooling classes should be displayed. For three-phase transformers, the kVA rating is the sum of the power in all three legs.

d. Voltage rating. The voltage rating should be given for the primary and secondary, and for all tap positions.

e. Temperature rise. The temperature rise is the allowable temperature change from ambient that the transformer can undergo without incurring damage.

f. Polarity (single phase). The polarity is important when the transformer is to be paralleled or used in conjunction with other transformers.

g. Phasor diagrams. Phasor diagrams will be provided for both the primary and the secondary coils. Phasor diagrams indicate the order in which the three phases will reach their peak voltages, and also the

angular displacement (rotation) between the primary and secondary.

h. Connection diagram. The connection diagram will indicate the connections of the various windings, and the winding connections necessary for the various tap voltages.

i. Percent impedance. The impedance percent is the vector sum of the transformer's resistance and reactance expressed in percent. It is the ratio of the voltage required to circulate rated current in the corresponding winding, to the rated voltage of that winding. With the secondary terminals shorted, a very small voltage is required on the primary to circulate rated current on the secondary. The impedance is defined by the ratio of the applied voltage to the rated voltage of the winding. If, with the secondary terminals shorted, 138 volts are required on the primary to produce rated current flow in the secondary, and if the primary is rated at 13,800 volts, then the impedance is 1 percent. The impedance affects the amount of current flowing through the transformer during short circuit or fault conditions.

j. Impulse level (BIL). The impulse level is the crest value of the impulse voltage the transformer is required to withstand without failure. The impulse level is designed to simulate a lightning strike or voltage surge condition. The impulse level is a withstand rating for extremely short duration surge voltages. Liquid-filled transformers have an inherently higher BIL rating than dry-type transformers of the same kVA rating.

k. Weight. The weight should be expressed for the various parts and the total. Knowledge of the weight is important when moving or unloading the transformer.

l. Insulating fluid. The type of insulating fluid is important when additional fluid must be added or when unserviceable fluid must be disposed of. Different insulating fluids should never be mixed. The number of gallons, both for the main tank, and for the various compartments should also be noted.

m. Instruction reference. This reference will indicate the manufacturer's publication number for the transformer instruction manual.

CHAPTER 2

CONSTRUCTION/THEORY

2-1. Transformer applications

A power transformer is a device that changes (transforms) an alternating voltage and current from one level to another. Power transformers are used to “step up” (transform) the voltages that are produced at generators to levels that are suitable for transmission

(higher voltage, lower current). Conversely, a transformer is used to “step down” (transform) the higher transmission voltages to levels that are suitable for use at various facilities (lower voltage, higher current). Electric power can undergo numerous transformations between the source and the final end use point (see figure 2-1).

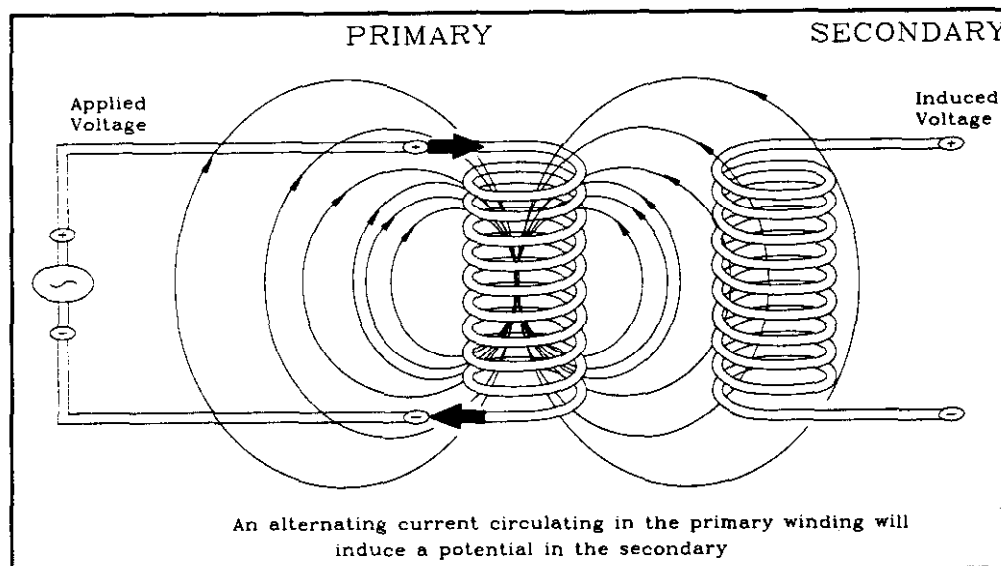

Figure 2-1. Distribution system schematic.

a. Voltages must be stepped-up for transmission. Every conductor, no matter how large, will lose an appreciable amount of power (watts) to its resistance (R) when a current (I) passes through it. This loss is expressed as a function of the applied current ($P=I^2 \times R$). Because this loss is dependent on the current, and since the power to be transmitted is a function of the applied volts (E) times the amps ($P=Ix E$), significant savings can be obtained by stepping the voltage up to a higher voltage level, with the corresponding reduction of the current value. Whether 100 amps is to be transmitted at 100 volts ($P=Ix E$; 100 amps \times 100 volts = 10,000 watts) or 10 amps is to be trans-

mitted at 1,000 volts ($P=Ix E$; 10 amps \times 1,000 volts = 10,000 watts) the same 10,000 watts will be applied to the beginning of the transmission line.

b. If the transmission distance is long enough to produce 0.1 ohm of resistance across the transmission cable, $P=I^2 R$; $(100 \text{ amp})^2 \times 0.1 \text{ ohm} = 1,000 \text{ watts}$ will be lost across the transmission line at the 100 volt transmission level. The 1,000 volt transmission level will create a loss of $P=I^2 R$; $(10 \text{ amp})^2 \times 0.1 \text{ ohm} = 10 \text{ watts}$. This is where transformers play an important role.

c. Although power can be transmitted more efficiently at higher voltage levels, sometimes as high as 500 or 750 thousand volts (kV), the devices and networks at

the point of utilization are rarely capable of handling voltages above 32,000 volts. Voltage must be "stepped down" to be utilized by the various devices available. By adjusting the voltages to the levels necessary for the various end use and distribution levels, electric power can be used both efficiently and safely.

d. All power transformers have three basic parts, a primary winding, secondary winding, and a core. Even though little more than an air space is necessary to insulate an "ideal" transformer, when higher voltages and larger amounts of power are involved, the insulating material becomes an integral part of the transformer's operation. Because of this, the insulation system is often considered the fourth basic part of the transformer. It is important to note that, although the windings and core deteriorate very little with age, the insulation can be subjected to severe stresses and chemical deterioration. The insulation deteriorates at a relatively rapid rate, and its condition ultimately determines the service life of the transformer.

2-2. Magnetic flux

The transformer operates by applying an alternating voltage to the primary winding. As the voltage increases, it creates a strong magnetic field with varying mag-

netic lines of force (flux lines) that cut across the secondary windings. When these flux lines cut across a conductor, a current is induced in that conductor. As the magnitude of the current in the primary increases, the growing flux lines cut across the secondary winding, and a potential is induced in that winding. This inductive linking and accompanying energy transfer between the two windings is the basis of the transformer's operation (see figure 2-2). The magnetic lines of flux "grow" and expand into the area around the winding as the current increases in the primary. To direct these lines of flux towards the secondary, various core materials are used. Magnetic lines of force, much like electrical currents, tend to take the path of least resistance. The opposition to the passage of flux lines through a material is called reluctance, a characteristic that is similar to resistance in an electrical circuit. When a piece of iron is placed in a magnetic field, the lines of force tend to take the path of least resistance (reluctance), and flow through the iron instead of through the surrounding air. It can be said that the air has a greater reluctance than the iron. By using iron as a core material, more of the flux lines can be directed from the primary winding to the secondary winding; this increases the transformer's efficiency.

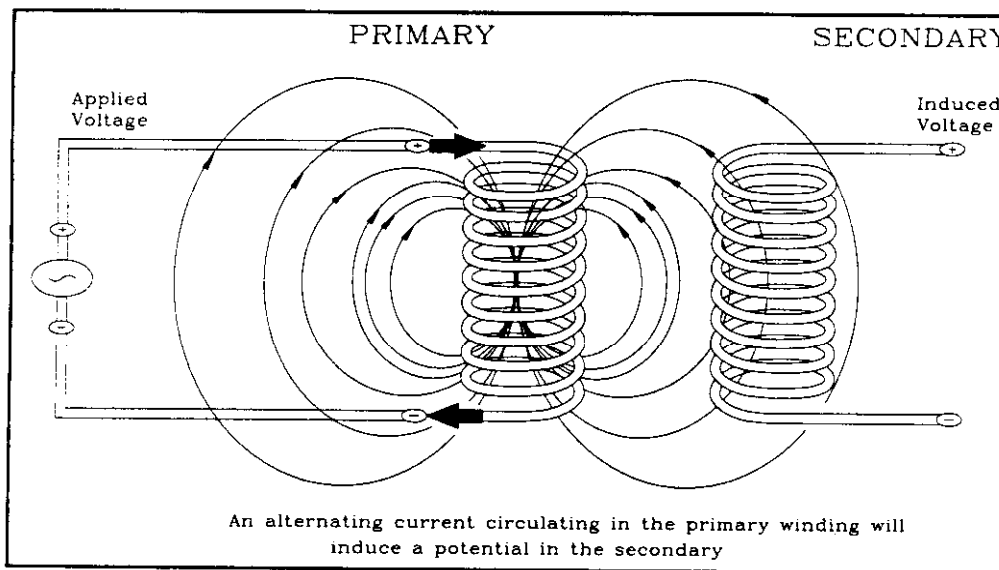

Figure 2-2. Transformer flux lines.

2-3. Winding, current and voltage ratios

If the primary and secondary have the same number of turns, the voltage induced into the secondary will be the same as the voltage impressed on the primary (see figure 2-3).

a. If the primary has more turns than the secondary,

then the voltage induced in the secondary windings will be stepped down in the same ratio as the number of turns in the two windings. If the primary voltage is 120 volts, and there are 100 turns in the primary and 10 turns in the secondary, then the secondary voltage will be 12 volts. This would be termed a "step down" transformer as shown in figure 2-4.

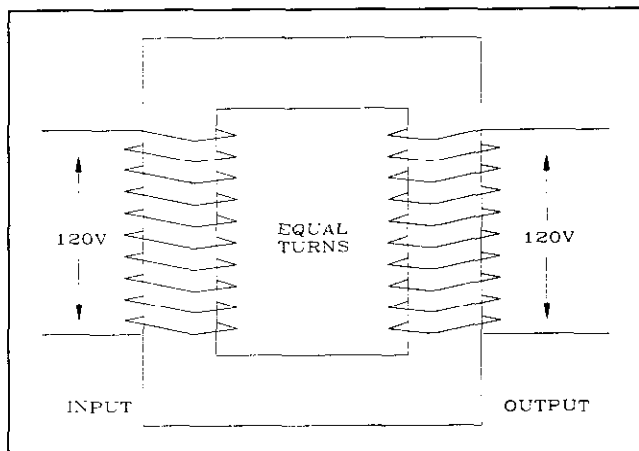

Figure 2-3. Transformer equal turns ratio.

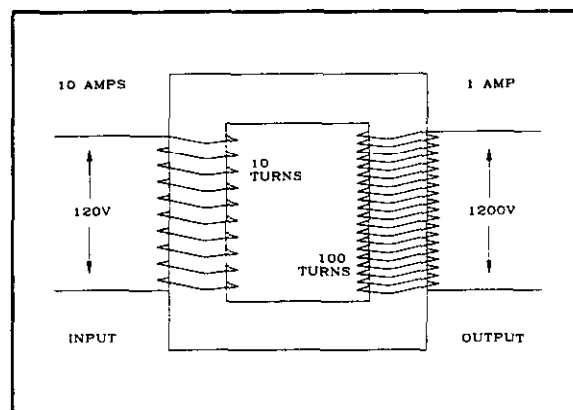

Figure 2-5. Transformer 1:10 turns ratio.

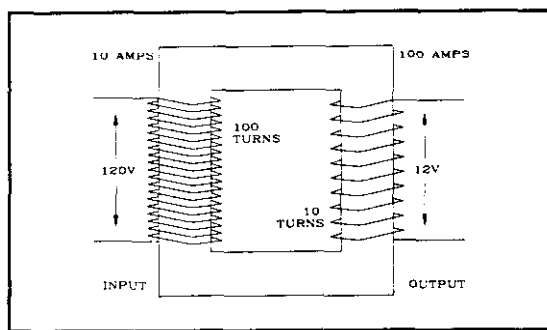

Figure 2-4. Transformer 10:1 turns ratio.

b. A “step up” transformer would have more turns on the secondary than on the primary, and the reverse voltage relationship would hold true. If the voltage on the primary is 120 volts, and there are 10 turns in the primary and 100 turns in the secondary, then the secondary voltage would be 1200 volts. The relationship between the number of turns on the primary and secondary and the input and output voltages on a step up transformer is shown in figure 5-2.

c. Transformers are used to adjust voltages and currents to the level required for specific applications. A transformer does not create power, and therefore ignoring losses, the power into the transformer must equal the power out of the transformer. This means that, according to the previous voltage equations, if the voltage is stepped up, the current must be stepped down. Current is transformed in inverse proportion to the ratio of turns, as shown in the following equations:

$$\frac{N_p \text{ (turns on primary)}}{N_s \text{ (turns on secondary)}} = \frac{I_s \text{ (amperes in secondary)}}{I_p \text{ (amperes in primary)}}$$

$$\frac{E_p \text{ (volts primary)}}{E_s \text{ (volts secondary)}} = \frac{I_s \text{ (amperes secondary)}}{I_p \text{ (amperes primary)}}$$

d. The amount of power that a transformer can handle is limited by the size of the winding conductors, and by the corresponding amount of heat they will product

when current is applied. This heat is caused by losses, which results in a difference between the input and output power. Because of these losses, and because they are a function of the impedance rather than pure resistance, transformers are rated not in terms of power (Watts), but in terms of kVA. The output voltage is multiplied by the output current to obtain volt-amps; the k designation represents thousands.

2-4. Core construction

To reduce losses, most transformer cores are made up of thin sheets of specially annealed and rolled silicone steel laminations that are insulated from each other. The molecules of the steel have a crystal structure that tends to direct the flux. By rolling the steel into sheets, it is possible to “orient” this structure to increase its ability to carry the flux.

a. As the magnetic flux “cuts” through the core materials, small currents called “eddy currents” are induced. As in any other electrical circuit, introducing a resistance (for example, insulation between the laminations), will reduce this current and the accompanying losses. If a solid piece of material were used for the core, the currents would be too high. The actual thickness of the laminations is determined by the cost to produce thinner laminations versus the losses obtained. Most transformers operating at 60 Hertz (cycles per second) have a lamination thickness between 0.01 and 0.02 in. Higher frequencies require thinner laminations.

b. The laminations must be carefully cut and assembled to provide a smooth surface around which the windings are wrapped. Any burrs or pointed edges would allow the flux lines to concentrate, discharge and escape from the core. The laminations are usually clamped and blocked into place because bolting would interrupt the flow of flux. Bolts also have a tendency to loosen when subjected to the vibrations that are found in a 60 cycle transformer's core. It is important that this

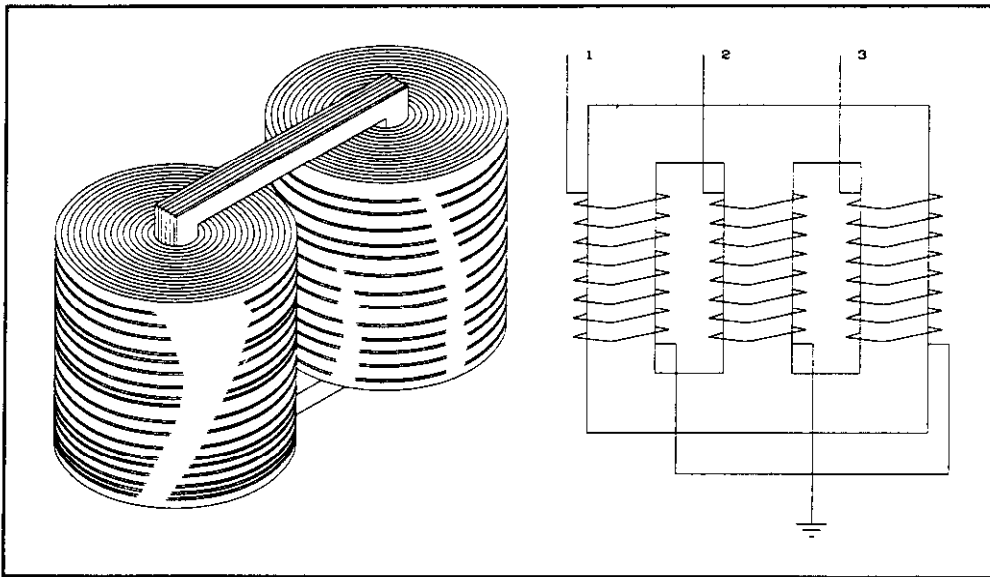

Figure 2-6. Transformer shell construction.

clamping arrangement remains tight; any sudden increase in noise or vibration of the transformer can indicate a loosening of the core structure.

2-5. Core form construction

There are two basic types of core assembly, core form and shell form. In the core form, the windings are wrapped around the core, and the only return path for the flux is through the center of the core. Since the core is located entirely inside the windings, it adds a little to the structural integrity of the transformer's frame. Core construction is desirable when compactness is a major requirement. Figure 2-6 illustrates a number of core type configurations for both single and multi-phase transformers.

2-6. Shell form construction

Shell form transformers completely enclose the windings inside the core assembly. Shell construction is used for larger transformers, although some core-type units are built for medium and high capacity use. The core of a shell type transformer completely surrounds the windings, providing a return path for the flux lines both through the center and around the outside of the windings (see figure 2-7). Shell construction is also more flexible, because it allows a wide choice of winding arrangements and coil groupings. The core can also act as a structural member, reducing the amount of external clamping and bracing required. This is especially important in larger application where large forces are created by the flux.

a. Certain wiring configurations of shell form transformers, because of the multiple paths available for the flux flow, are susceptible to higher core losses due to harmonic generations. As the voltage rises and falls at

the operating frequency, the inductance and capacitance of various items in or near the circuit operate at a frequency similar to a multiple of the operating frequency. The "Third Harmonic" flows primarily in the core, and can triple the core losses. These losses occur primarily in Wye-Wye configured transformers (see chapter 3).

b. The flux that links the two windings of the transformer together also creates a force that tends to push the conductors apart. One component of this force, the axial component, tends to push the coils up and down on the core legs, and the tendency is for the coils to slide up and over each other. The other component is the longitudinal force, where the adjacent coils push each other outward, from side to side. Under normal conditions, these forces are small, but under short circuit conditions, the forces can multiply to hundreds of times the normal value. For this reason, the entire coil and winding assembly must be firmly braced, both on the top and bottom and all around the sides. Bracing also helps to hold the coils in place during shipping.

c. The bracing also maintains the separation that is a necessary part of the winding insulation, both from the tank walls, and from the adjacent windings. Nonconductive materials, such as plastic, hardwood or plywood blocks are used to separate the windings from each other and from the tank walls. These separations in the construction allow paths for fluid or air to circulate, both adding to the insulation strength, and helping to dissipate the heat thereby cooling the windings. This is especially important in large, high voltage transformers, where the heat buildup and turn-to-turn separations must be controlled.

d. The windings of the transformer must be separated (insulated) from each other and from the core, tank, or other grounded material. The actual insulation

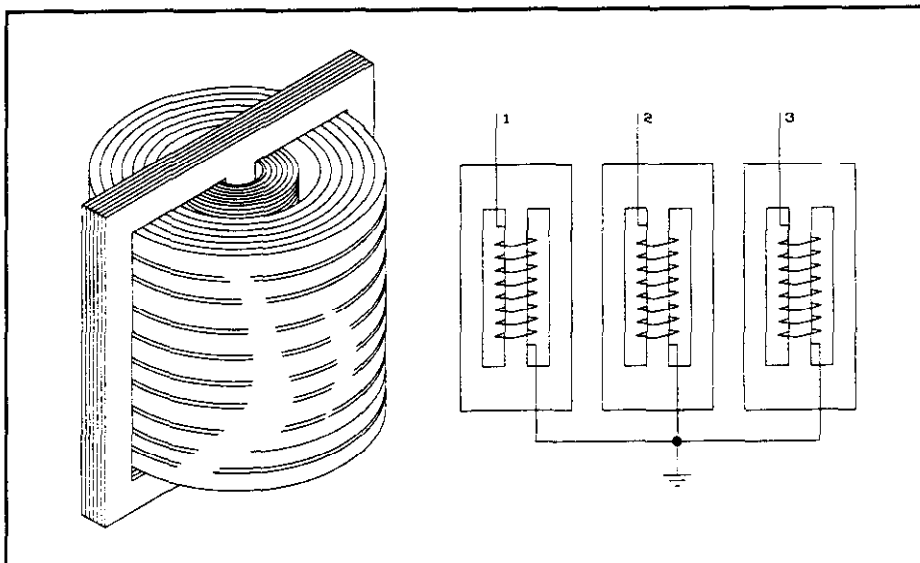

Figure 2-7. Transformer shell construction.

between the turns of each winding can usually be provided by a thin enamel coating or a few layers of paper. This is because the entire voltage drop across the windings is distributed proportionately across each turn. In other words, if the total voltage drop across a winding is 120 volts, and there are 100 turns in that winding, the potential difference between each turn is 1.2 volts (120/100).

e. Transformers are designed to withstand impulse levels several times, and in some cases, hundreds of times higher than one operating voltage. This is to provide adequate protection in the case of a lightning strike, a switching surge or a short circuit. By allowing oil to circulate between the windings, the turn-to-turn insulating level can be appreciably increased and the amount of heat built up in the windings can be efficiently dissipated.

f. Most large power transformers have their windings immersed in some type of fluid. Although larger dry-type transformers are constantly being produced, and many new forms of construction, such as resin cast and gas filled, are being used for power applications, the most common method of insulating the windings and dissipating the heat is by submerging the windings and core in an insulating fluid. Silicone, trichloroethane, and a wide variety of low fire point hydrocarbon based fluids are just a few of the fluids currently in use. This manual primarily applies to mineral oil-filled transformers. Although there are similarities between mineral oil and many other fluids being used, the manufacturer's specifications and instructions for each fluid should always be considered. Any reference in this

manual to insulating, unless otherwise stated, will be implied to mean mineral oil.

g. Heat must be dissipated by fluid because no transformer is 100 percent efficient. There are many forms of losses in a transformer, and although they have different sources, the resultant product of these losses is heat build up within the tank. Transformer losses can be divided into two general categories, load losses and no-load losses. No-load losses are independent of the applied load, and include core losses, excitation losses, and dielectric losses in the insulation. Load losses consist of the copper losses across the windings that are produced by the applied current (I^2R), and of the stray currents in the windings that appear when the load is applied. These losses are usually listed by the manufacturer for each type of transformer. They are especially important when considering the cooling requirements of the transformer.

h. Some of the important transformer equations are as follows:

Basic transformer ratio:

$$\frac{N_p \text{ (# turns primary)}}{N_s \text{ (# turns secondary)}} = \frac{E_p \text{ (volts primary)}}{E_s \text{ (volts secondary)}}$$

Current equation:

$$I_p \times N_p = I_s \times N_s$$

Percent efficiency:

$$\frac{\text{output} \times 100\%}{\text{input}} = \frac{\text{output} \times 100\%}{\text{output} + \text{losses}}$$

CHAPTER 3

TRANSFORMER CONNECTIONS AND TAPS

3-1. Tapped primaries and secondaries

To compensate for changing input voltages, multiple connections or "taps" are provided to allow different portions of the winding to be used. When the taps are connected on the primary winding, the turn-to-turn

ratio is changed, and the required secondary voltage can be obtained in spite of a change in source voltage. Manufacturers usually provide taps at 2-1/2 percent intervals above and below the rated voltage (see figure 3-1) Taps at 2.5 percent allow the number of turns on the primary to change.

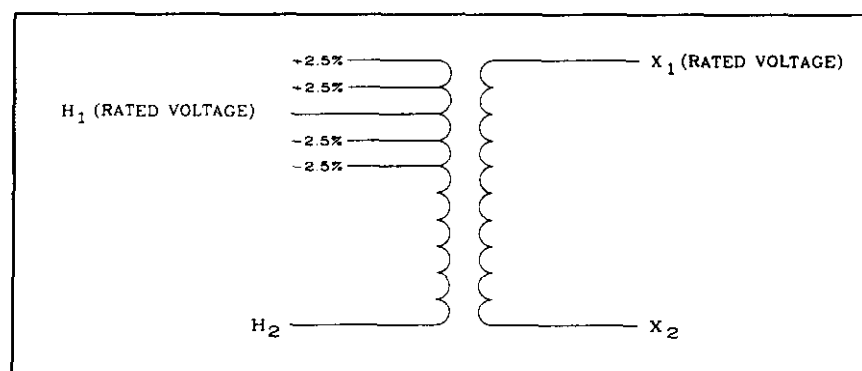

Figure 3-1. Transformer taps.

a. Taps are usually changed by turning a crank or hand-wheel, although some transformers require that a cover be removed and the actual winding leads be connected on a terminal board where all of the taps can be accessed. Tap changers can be either "Load Tap Changing" or "No-Load Tap (N.L.T.) Changing" units, although most of them must be changed with the transformer de-energized.

b. Smaller single-phase transformers are usually provided with center-tapped secondaries, with the leads brought out from both halves of the tapped winding. When the center tap leads are connected together, that winding becomes one continuous coil, and it is said to be connected in series (see figure 3-2). Because the maximum number of turns are used, the maximum voltage is obtained, at the corresponding current level.

c. When the center taps are connected to the opposite output leads, the winding becomes two separate windings working in parallel (see figure 3-2). A lower voltage at a corresponding higher current level is obtained.

3-2. Polarity

Note that, when the center tap is connected in parallel, both windings are oriented in the same direction with respect to the primary. The clockwise or counterclockwise direction that the windings are wound on the core determine the direction of the current flow (the right-hand rule). This relationship of winding orientation to current flow in the transformer is known as polarity.

a. The polarity of a transformer is a result of the relative winding directions of the transformer primary conductor with respect to the transformer secondary (see figure 3-3). Polarity is a function of the transformer's construction. Polarity becomes important when more than one transformer is involved in a circuit. Therefore, the polarities and markings of transformers are standardized. Distribution Transformers above 200 KVA or above 860 volts are "subtractive."

b. Transformer polarity is an indication of the direction of current flow through the high-voltage terminals,

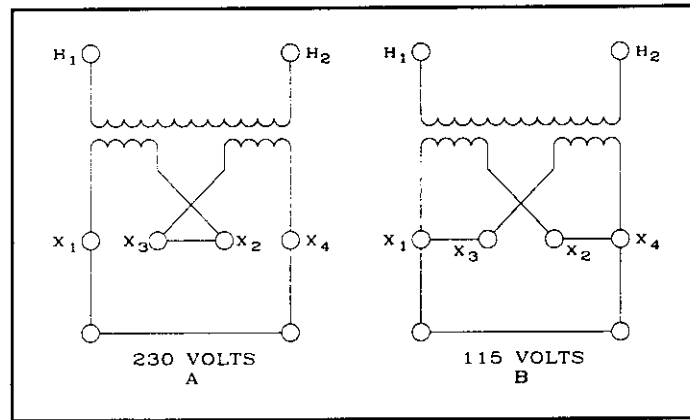

Figure 3-2. Single phase transformer secondary winding arrangements.

with respect to the direction of current flow through the low-voltage terminals at any given instant in the alternating cycle. Transformers are constructed with additive or subtractive polarity (see figures 3-4). The terminal markings on transformers are standardized among the various manufacturers, and are indicative of the polarity. However, since there is always the possibility that the wiring of a transformer could have been changed, it is important to check the transformer's polarity before making any wiring changes.

c. The polarity is subtractive when the high-side lead (H1) is brought out on the same side as the low-side lead (X1). If a voltage is placed on the high-side, and a jumper is connected between the H1 and X1 terminals (see figure 3-5), the voltage read across the H2 and X2 terminals will be less than the applied voltage. Most large power transformers are constructed with subtractive polarity.

d. When the high-side lead (H1) is brought out on the opposite side of the low-side lead (X1) and is on the same side as the low side lead (X2), the polarity is additive. If a voltage is placed across the high-side, and a

jumper is connected between the H1 and X2 terminals, the voltage read across the H2 and X1 terminals will be greater than the applied voltage (see figure 23-6).

3-3. Autotransformers

Although the examples illustrated up to this point have used two separate windings to transform the voltage and current, this transformation can be accomplished by dividing one winding into sections. The desired ratio can be obtained by "tapping" the winding at a prescribed point to yield the proper ratio between the two sections. This arrangement is called an "Autotransformer."

a. Even though the winding is continuous, the desired voltages and currents can be obtained. Although an autotransformer is made up of one continuous winding, the relationship of the two sections can be more readily understood if they are thought of as two separate windings connected in series. Figure 3-7 shows the current and voltage relationships in the various sections of an autotransformer.

b. Autotransformers are inherently smaller than nor-

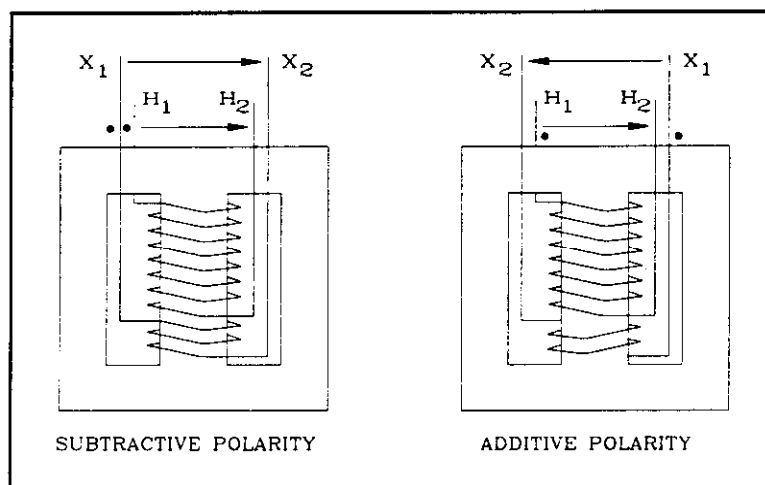

Figure 3-3. Physical transformer polarity.

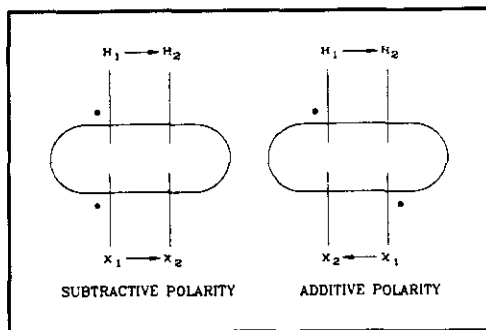

Figure 3-4. Diagrammatic transformer polarity.

mal two-winding transformers. They are especially suited for applications where there is not too much difference between the primary and secondary voltages (transformer ratios usually less than 5:1). An autotransformer will have lower losses, impedance, and excitation current values than a two-winding transformer of the same KVA rating because less material is used in its construction.

c. The major drawback of autotransformers is that they do not provide separation between the primary and secondary. This non-insulating feature of the autotransformer should always be remembered; even though a low voltage may be tapped from an autotransformer, the low voltage circuit must be insulated to the same degree as the high voltage side of the transformer. Another drawback is that the autotransformer's impedance is extremely low, and it provides almost no opposition to fault current. Autotransformers are usually primarily for motor starting circuits, where lower voltages are required at the start to reduce the amount of inrush current, and higher voltages are used once the motor is running. Autotransformers are used in power

applications where the difference between the primary and secondary voltages is not too great.

3-4. Single and multi-phase relationships

All transformations occur on a single-phase basis; three-phase transformers are constructed by combining three single-phase transformers in the same tank. As indicated by its name, a single-phase transformer is a transformer that transforms one single-phase voltage and current to another voltage and current level.

a. Alternating current single-phase power can be represented by a graph of constantly changing voltage versus time (a sine wave). The potential changes continuously from positive to negative values over a given time period. When the voltage has gone through one complete series of positive and negative changes, it is said to have completed one cycle. This cycle is expressed in degrees of rotation, with 360 degrees representing one full cycle. As shown in figure 3-8 a start point is designated for any sine wave. The sine wave position and corresponding voltage can be expressed in degrees of rotation, or degrees of displacement from the starting point.

b. This alternating voltage can be readily produced by rotating generators, and in turn can be easily utilized by motors and other forms of rotating machinery. Single-phase power is used primarily in residential or limited commercial applications.

c. Most industrial or institutional systems utilize a three-phase power configuration. Three single-phase lines are used (A, B and C), and it is only when they are connected to an end use device, such as a motor or transformer that their relationships to each other become important. By convention, the individual phas-

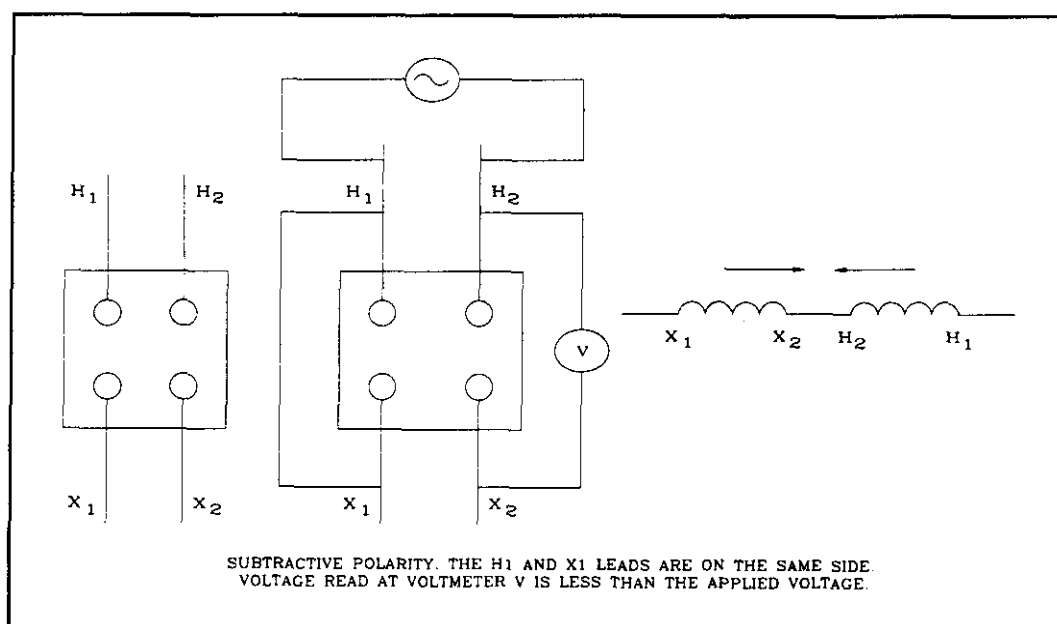

Figure 3-5. Transformer subtractive polarity test.

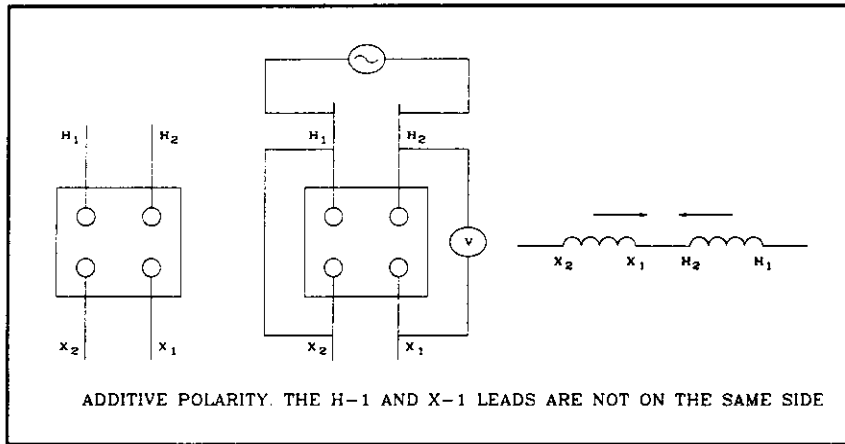

Figure 3-6. Transformer additive polarity test.

es of a three-phase distribution system are displaced 120 degrees (one third of a cycle) apart (see figure 3-9).

d. Rather than draw sine waves to show the position of the phases, the relative angular displacement (degrees ahead of or later than) is depicted by phasor diagrams. Phasor diagrams are convenient because they not only show the angular displacement, but they also show how the phases are physically connected. Transformer manufacturers use phasor diagrams on the nameplate of the transformer to indicate the connections and angular displacement of the primary and secondary phases (see figure 3-10). The polarity of three-phase transformers is determined both by where the leads are brought out of the transformer, and by the connection of the phases inside the tank. The two most common connections for three-phase transformers are delta and wye (star).

e. Delta and wye are the connections and relations of the separate phase on either the primary or the sec-

ondary windings. The basic three-phase transformer primary-to-secondary configurations are as follows:

- Delta-delta
- Delta-wye
- Wye-wye
- Wye-delta

f. These configurations can be obtained by connecting together three single-phase transformers or by combining three single-phase transformers in the same tank. There are many variations to these configurations, and the individual transformer's design and application criteria should be considered.

g. The wye connection is extremely popular for use on the secondary of substation transformers. By connecting the loads either phase-to-phase or phase-to-neutral, two secondary voltages can be obtained on the secondary. A common secondary voltage on many distribution transformers is 208/120V, with the 208V (phase-to-phase) connections being used to supply motors, and the 120V (phase-to-neutral) connections

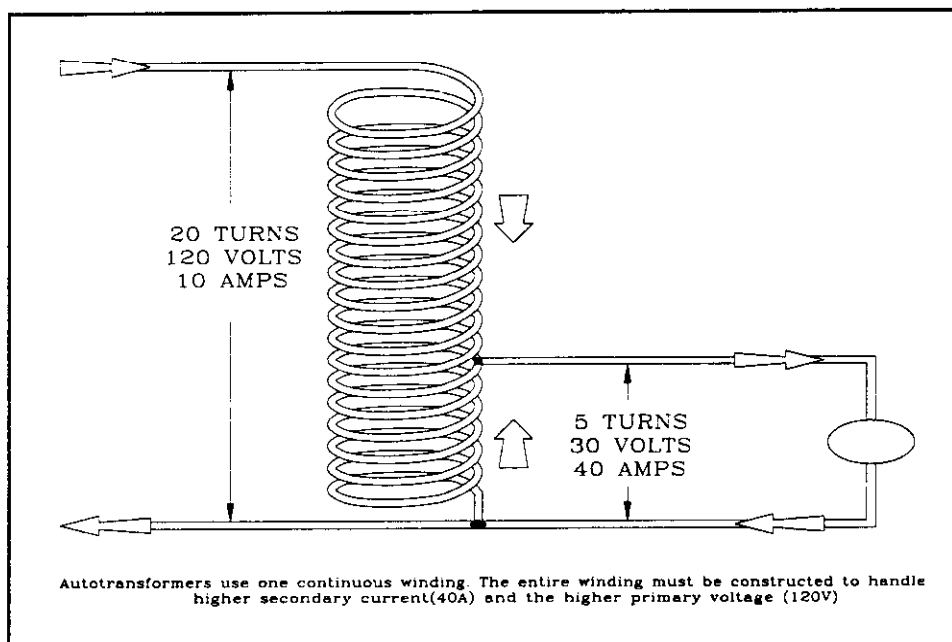

Figure 3-7. Autotransformer.

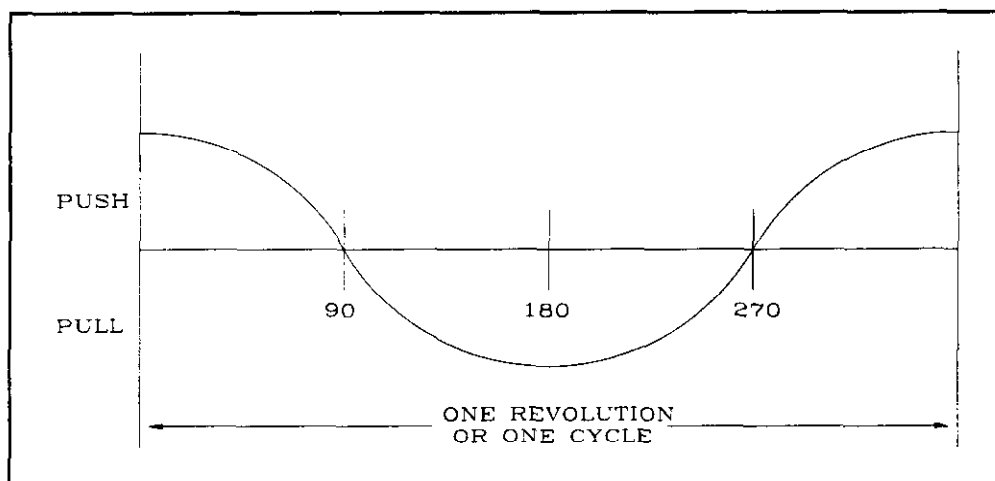

Figure 3-8. Sine wave.

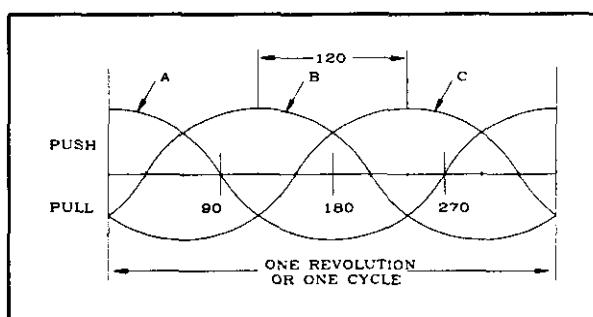

Figure 3-9. Three phase sine waves.

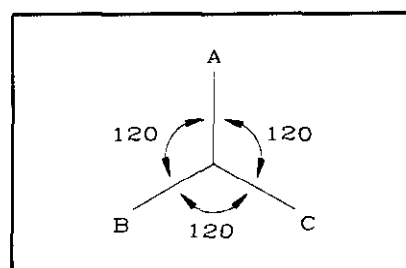

Figure 3-10. Three phase phasor diagram.

being used to supply lighting loads (see figure 3-11). These secondary voltages are related by the square root of three (1.73). As shown in figure 3-11, this configuration provides an added degree of flexibility.

h. Often, when ground fault is desired for certain circuits, the neutral will be isolated and carried throughout the circuit (except at the system ground point, usually the wye-grounded secondary transformer

connection) providing an isolated return path for load currents. This provides an opportunity to monitor these currents and to open the circuit in the event of a ground fault. Although the neutral is eventually grounded, it is isolated for the portion of the circuit where ground fault protection is needed (usually in the switchgear between the transformer secondary and the individual circuit breakers). It is important in these configurations to maintain the isolation of the neutral conductor. The common practice of bonding neutrals to ground at

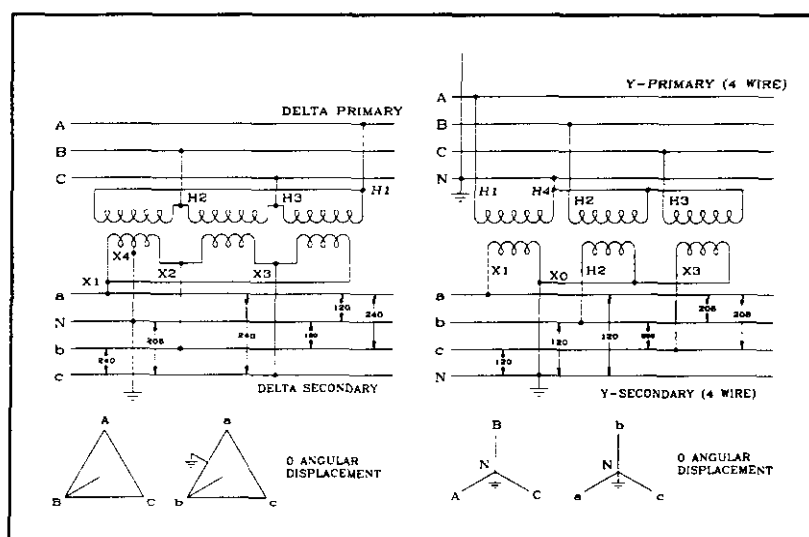

Figure 3-11. Delta-delta and wye-wye transformer configurations.

every possible point can defeat this protective scheme and render ground fault protection inoperative.

i. When the neutral conductor is grounded, it provides a stabilizing effect on the circuit. With the neutral point solidly grounded, the voltage of any system conductor, with respect to ground, cannot exceed the phase-to-phase voltage. Without grounding the neutral, any stable ground fault on one line raises the voltage of the two remaining lines with respect to ground, to a point as high as the phase-to-phase voltage. The implications are obvious; there will be less stress placed on the system insulation components with the wye-grounded connection.

3-5. Delta-wye and wye-delta displacements

As current and voltage are transformed in the individual phases of a wye-delta or delta-wye transformer, they can also have an angular displacement that occurs between the primary and secondary windings. That is, the primary wave-form of the A phase at any given instant is always 30 degrees ahead of or displaced from the wave form of the A phase on the secondary. This 30 degree shift occurs only between the primary and secondary and is independent of the 120 degrees of displacement between the other phases.

a. By convention, delta-delta and wye-wye transformers have zero degrees angular displacement between primary and secondary. See the phasor diagrams in figure 3-11. The individual wave forms between the primary and secondary are identical at any given instant. Delta-wye and wye-delta transformers have an angular displacement of 30 degrees. For these types of connections, the high-voltage reference phase angle side of the transformer is 30 degrees ahead of the low-voltage reference phase angle at any given instant

for each individual phase. This displacement is represented on the transformer's nameplate by a rotation of the phasor diagrams between the primary and secondary. See the phasor diagrams in figure 3-12.

b. Most manufacturers conform to American National Standards Institute (ANSI) Standard C57.12.70, "Terminal markings for Distribution and Power Transformers" (R1993), for the lead markings of larger (subtractive polarity) three-phase power transformers. The high-voltage lead, H1 is brought out on the right side when facing the high voltage side of the transformer case. The remaining high-voltage leads H2 and H3 are brought out and numbered in sequence from right to left. The low-voltage lead, X1 is brought out on the left side (directly opposite the H1 terminal) when facing the low side of the transformer. The remaining leads, X2 and X3 are numbered in sequence from left to right (see figure 3-13). It is important to note that these are suggested applications, and design constraints can require that a transformer be built with different markings. It is also important to remember that in many existing installations, there is the possibility that the leads have been changed and do not conform to the standardized markings.

c. Figure 3-14 shows the standard delta-wye three-phase transformer's nameplate illustrating many of the topics covered in this chapter. The various primary tap voltages, along with the numbered connection points on the actual windings are referenced in the "Connections" table. The wiring diagram shows the relationship and connections of the individual windings, while the phasor diagrams show the phase angle relationship between the individual phases, and between the primary and secondary. Note also that the temperature requirements, the tank pressure capabilities, and the expansion and contraction-versus-temperature values are spelled out.

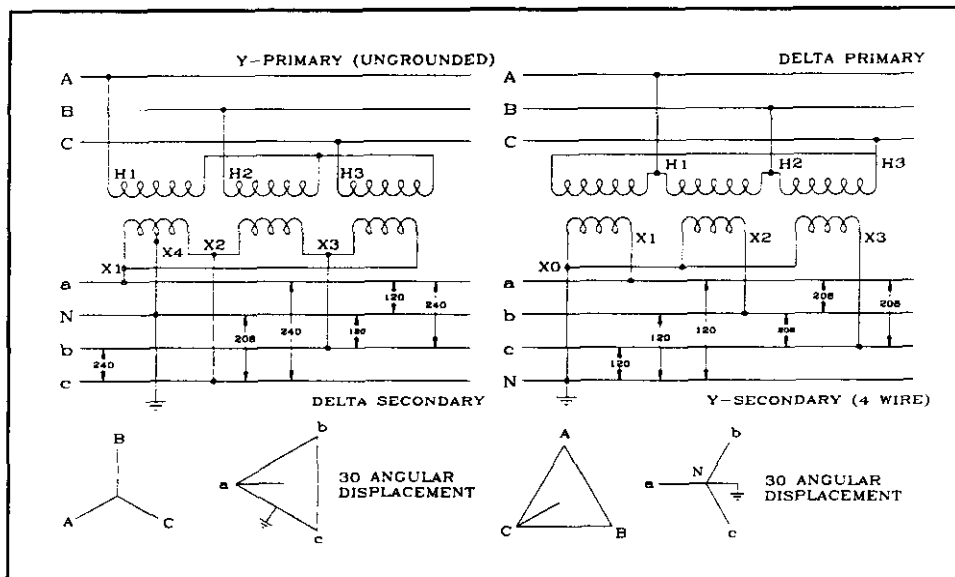

Figure 3-12. Wye-delta and delta-wye transformer configuration.

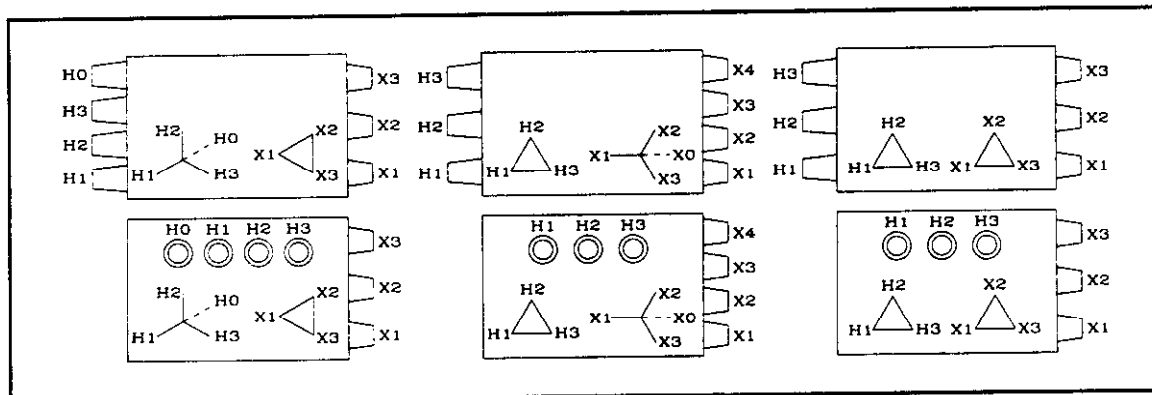

Figure 3-13. Transformer lead markings.

TRANSFORMER

SERIAL NO. 940732.B CLASS OA/FFA THREE PHASE 60 HERTZ

HV VOLTS 13800GY/7970 MFG. DATE

LV VOLTS 4160 DELTA

KVA RATING 3750 CONTINUOUS 65 C RISE

IMPEDANCE MIN 7.00% AT 3750 KVA

HV WINDING CONNECTIONS				WINDING MATERIAL	
VOLTS	AMPS	TAP	CONNECTS	HV	LV
H1-H2-H3			KVA	CU	
14490	149.4	A	1 TO 2	CU	
14145	153.0	B	2 OF 3		
13800	156.9	C	3 TO 4	CU	
13455	160.9	D	4 TO 5		
13110	165.1	E	5 TO 6	CU	
--	--	F	6 TO 7		
--	--	G	7 TO 8		

LV WINDING CONNECTIONS	
VOLTS	AMPS
X1-X2-X3	
4160	520.4

BIL LEVELS	
HV WINDING	95 KV
HV NEUTRAL	95 KV
HV NEUTRAL BUSHING	95 KV
LV WINDING	60 KV

CAUTION:
DE-ENERGIZE TRANSFORMER
BEFORE CHANGING TAPS

LIQUID TYPE OIL CONTAINS LESS THAN 1 PPM OF PCB FLUID AT TIME OF MANUFACTURE. LIQUID LEVEL BELOW TOP OF MANHOLE FLANGE AT 25 C IS 216 MILLIMETERS LIQUID LEVEL CHANGES 11.00 MM PER 10 C CHANGE IN LIQUID TEMPERATURE. MAXIMUM OPERATING PRESSURES OF LIQUID PRESERVATION SYSTEM 68.95kPa POSITIVE AND 55.16kPa NEGATIVE. TANK SUITABLE FOR 48.26kPa VACUUM FILLING.

APPROXIMATE WEIGHTS IN POUNDS			
2498 LITERS LIQ.	2245 KGS	TANK & FITTINGS	2012 KGS
CORE & COILS	3824 KGS	TOTAL	8038 KGS

CAUTION: BEFORE INSTALLING OR OPERATING READ INSTRUCTION BOOK 43500-054-04

MADE IN U.S.A.

Figure 3-14. Wye delta transformer nameplate.

CHAPTER 4

COOLING/CONSTRUCTION CLASSIFICATIONS

4-1. Classifications

Although transformers can be classified by core construction (shell or core type), the more functional types of standardized classifications are based on how the transformer is designed for its specific application, and how the heat created by its losses is dissipated. There are several types of insulating media available. Two basic classifications for insulating media are dry-type and liquid filled.

4-2. Dry-type transformers

Dry-type transformers depend primarily on air circulation to draw away the heat generated by the transformer's losses. Air has a relatively low thermal capacity. When a volume of air is passed over an object that has a higher temperature, only a small amount of that object's heat can be transferred to the air and drawn away. Liquids, on the other hand, are capable of drawing away larger amounts of heat. Air cooled transformers, although operated at higher temperatures, are not capable of shedding heat as effectively as liquid cooled transforms. This is further complicated by the inherent inefficiency of the dry-type transformer. Transformer oils and other synthetic transformer fluids are capable of drawing away larger quantities of excess heat.

a. Dry-type transformers are especially suited for a number of applications. Because dry-type transformers have no oil, they can be used where fire hazards must be minimized. However, because dry-type transformers depend on air to provide cooling, and because their losses are usually higher, there is an upper limit to their size (usually around 10,000 kVA, although larger ones are constantly being designed). Also, because oil is not available to increase the dielectric strength of the insulation, more insulation is required on the windings, and they must be wound with more clearance between the individual turns.

b. Dry-type transformers can be designed to operate at much higher temperatures than oil-filled transformers (temperature rises as high as 150 °C). Although oil is capable of drawing away larger amounts of heat, the actual oil temperature must be kept below approximately 100 °C to prevent accelerated breakdown of the oil.

c. Because of the insulating materials used (glass, paper, epoxy, etc.) and the use of air as the cooling medium, the operating temperatures of dry-type trans-

formers are inherently higher. It is important that adequate ventilation be provided. A good rule of thumb is to provide at least 20 square feet of inlet and outlet ventilation in the room or vault for each 1,000 kVA of transformer capacity. If the transformer's losses are known, an air volume of 100 cfm (cubic feet per minute) for each kW of loss generated by the transformer should be provided. Dry-type transformers can be either self-cooled or forced-air cooled.

d. A self-cooled dry-type transformer is cooled by the natural circulation of air through the transformer case. The cooling class designation for this transformer is AA. This type of transformer depends on the convection currents created by the heat of the transformer to create an air flow across the coils of the transformer.

e. Often, fans will be used to add to the circulation of air through the case. Louvers or screened openings are used to direct the flow of cool air across the transformer coils. The kVA rating of a fan-cooled dry-type transformer is increased by as much as 33 percent over that of a self-cooled dry-type of the same design. The cooling class designation for fan cooled or air blast transformers is FA. Dry-type transformers can be obtained with both self-cooled and forced air-cooled ratings. The designation for this type of transformers is AA/FA.

f. Many other types of dry-type transformers are in use, and newer designs are constantly being developed. Filling the tank with various types of inert gas or casting the entire core assemblies in epoxy resins are just a few of the methods currently in use. Two of the advantages of dry-type transformers are that they have no fluid to leak or degenerate over time, and that they present practically no fire hazard. It is important to remember that dry-type transformers depend primarily on their surface area to conduct the heat away from the core. Although they require less maintenance, the core and case materials must be kept clean. A thin layer of dust or grease can act as an insulating blanket, and severely reduce the transformer's ability to shed its heat.

4-3. Liquid-filled transformers

Liquid-filled transformers are capable of handling larger amounts of power. The liquid (oil, silicone, PCB etc.) transfers the heat away from the core more effectively than air. The liquid can also be routed away from the main tank, into radiators or heat exchangers to further increase the cooling capacity. Along with cooling the

transformer, the liquid also acts as an insulator. Since oils and synthetics will break down and lose their insulating ability at higher temperatures, liquid filled transformers are designed to operate at lower temperatures than dry-types (temperature rises around 55 °C). Just as with dry-types, liquid-filled transformers can be self-cooled, or they can use external systems to augment the cooling capacity.

a. A self-cooled transformer depends on the surface area of the tank walls to conduct away the excess heat. This surface area can be increased by corrugating the tank wall, adding fins, external tubing or radiators for the fluid. The varying heat inside the tank creates convection currents in the liquid, and the circulating liquid draws the heat away from the core. The cooling class designation for self-cooled, oil-filled transformers is OA.

b. Fans are often used to help circulate the air around the radiators. These fans can be manually or automatically controlled, and will increase the transformer's kVA capacity by varying amounts, depending on the type of construction. The increase is usually around 33 percent, and is denoted on the transformer's nameplate by a slash (/) rating. Slash ratings are determined by the manufacturer, and vary for different transformers. If loading is to be increased by the addition of pumps or fans, the manufacturer should be contacted. The cooling class designation for a forced air-cooled, oil-filled transformer is OA/FA.

c. Pumps can be used to circulate the oil in the tank and increase the cooling capacity. Although the convection currents occur in the tank naturally, moving the oil more rapidly past the radiators and other heat exchangers can greatly increase their efficiency. The pumps are usually installed where the radiators join the tank walls, and they are almost always used in conjunction with fans. The cooling class designation for forced oil and forced air cooled transformers is OA/FA/FOA.

d. To obtain improved cooling characteristics, an auxiliary tubing system is often used to circulate water through the transformer's oil. This type of design is especially suited for applications where sufficient air circulation cannot be provided at the point of installation, such as underground, inside of buildings, or for specialized applications in furnace areas. Because water is used to draw off the heat, it can be piped to a remote location where heat exchangers can be used to dissipate the heat. In this type of construction, tubing is used to circulate water inside the tank. The tubing circulates through the oil near the top, where it is the hottest; great pains must be taken to ensure that the tubing does not leak, and to allow the water to mix with the oil. Water is especially desirable for this application because it has a higher thermal capacity than oil. If untreated water is used, steps must be taken to ensure that the pipes do not become clogged by contaminants, especially when hard water is used. The cooling class designation for water-cooled transformers is FOW.

4-4. Tank construction

Transformers can also be classified according to tank construction. Although the ideal transformer is a static device with no moving parts, the oil and the tank itself are constantly expanding and contracting, or "breathing," according to the changing temperatures caused by the varying load of the transformer.

a. When the oil is heated, it expands (0.08 percent volume per °C) and attempts to force air out of the tank. Thermal expansion can cause the oil level in the tank to change as much as 5 or 6 inches, depending on the type of construction. This exhaust cycle causes no harm. It is on the contraction cycle that outside air can be drawn into the tank, contaminating the oil.

b. When oxygen and moisture come in contact with oil at high temperatures, the oil's dielectric strength is reduced, and sludge begins to form. Sludge blocks the flow of oil in the tank and severely reduces the transformer's cooling capacity. Various types of tank construction are utilized to accommodate the transformer's expansion and contraction cycles while preventing the oil from being contaminated.

4-5. Free breathing tanks

Free-breathing tanks are maintained at atmospheric pressure at all times. The passage of outside air is directed through a series of baffles and filters. Dehydrating compounds (such as calcium chloride or silica gel) are often placed at the inlet to prevent the oil from being contaminated. Free breathing transformers substantially reduce the pressure forces placed on the tank, but are not very effective at isolating the oil. Even if the moisture is removed, the air will still contain oxygen and cause sludging. Also, if the dehydrating compounds are not replaced regularly, they can become saturated and begin "rehydrating" the incoming air and adding moisture to the oil.

4-6. Conservator tanks

Conservator or expansion type tanks use a separate tank to minimize the contact between the transformer oil and the outside air (see figure 4-1). This conservator tank is usually between 3 and 10 percent of the main tank's size. The main tank is completely filled with oil, and a small conservator tank is mounted above the main tank level. A sump system is used to connect the two tanks, and only the conservator tank is allowed to be in contact with the outside air.

a. By mounting the sump at a higher level in the conservator tank, sludge and water can form at the bottom of the conservator tank and not be passed into the main tank. The level in the main tank never changes, and the conservator tank can be drained periodically to remove the accumulated water and sludge. Conservator tank transformers often use dehydrating breathers at the inlet port of the conservator tank to further minimize the possibility of contamination.

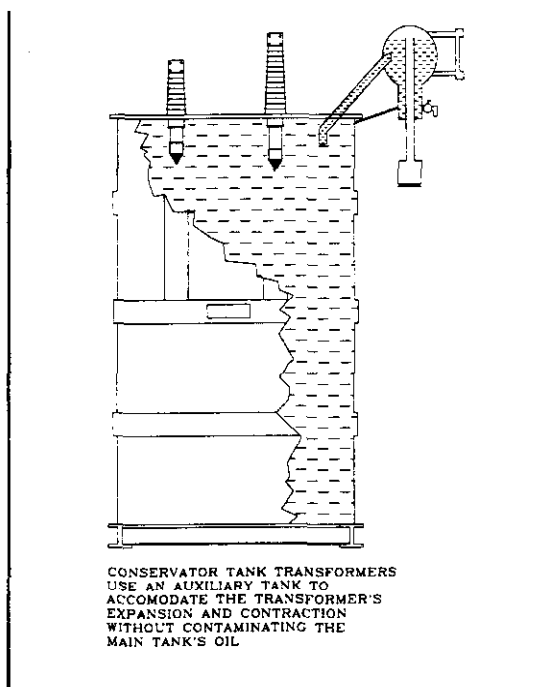

Figure 4-1. Conservator tank transformers.

b. Although this design minimizes contact with the oil in the main tank, the auxiliary tank's oil is subjected to a higher degree of contamination because it is making up for the expansion and contraction of the main tank. Dangerous gases can form in the head space of the auxiliary tank, and extreme caution should be exercised when working around this type of transformer. The auxiliary tank's oil must be changed periodically, along with a periodic draining of the sump.

4-7. Gas-oil sealed tanks

The gas-oil sealed tank is similar to the conservator tank, in that an auxiliary tank is used to minimize the oil's contact with the atmosphere (see figure 4-2). However, in this type of design, the main tank oil never actually comes in contact with the auxiliary tank's oil. When the main tank's oil expands and contracts, the gas in the head space moves in and out of the auxiliary tank through a manometer type set-up. The auxiliary tank is further divided into two sections, which are also connected by a manometer. The levels of both sections of the auxiliary tank and main tank can rise and fall repeatedly, and the main tank's oil will never come in contact with the outside atmospheres. The oil in the auxiliary tank is subject to rapid deterioration, and just as in the conservator type, gases and potent acids can form in the auxiliary tank if the oil is not drained and replaced periodically.

4-8. Automatic inert gas sealed tanks

Some transformers use inert gas systems to completely eliminate contamination (see figure 4-3). These systems are both expensive and complicated, but are very

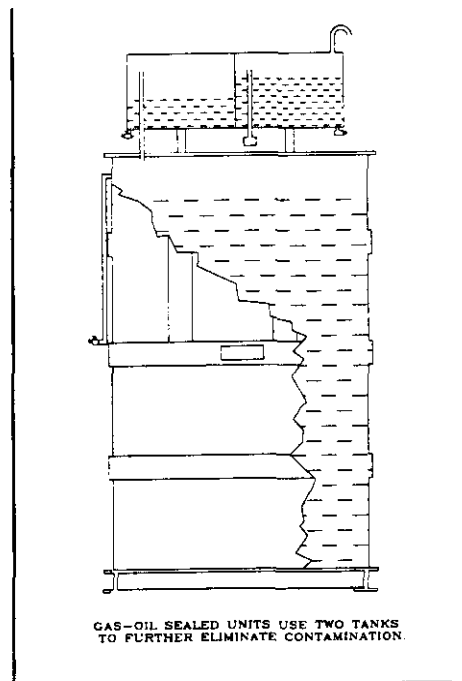

Figure 4-2. Gas-oil sealed transformers.

effective. The pressure in the tank is allowed to fluctuate within certain levels (+/- 5 psi), and any excess pressure is simply bled off into the atmosphere. When the transformer cools and begins its intake cycle, the in-going gas is supplied from a pressurized nitrogen bottle. Nitrogen gas has little detrimental effect on the transformer oil and is not a fire or explosion hazard. Inert gas systems (sometimes called pressurized gas systems) have higher initial installation costs, and require more periodic attention throughout their life than non-pressurized gas systems.

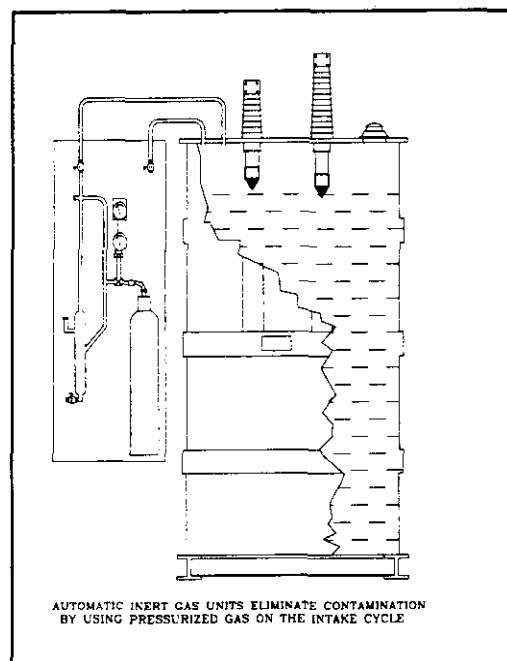

Figure 4-3. Automatic inert gas sealed transformers.

4-9. Sealed tank type

Sealed tank units (see figure 4-4) are the most common type of construction. The tank is completely sealed and constructed to withstand a moderate amount of contraction and expansion (usually +/- 5 psi). This pressure difference will usually cover the fluctuations the transformer will undergo during normal operation.

a. A gas blanket, usually nitrogen, is placed over the oil in the main tank and this "cushion" helps to absorb most of the forces created by the pressure fluctuations. A slight pressure (around 1 psi) is maintained on the tank to prevent any unwanted influx of air or liquid. The higher pressures caused by severe overloading, arcing, or internal faults are handled by pressure relief devices.

b. There are many auxiliary systems and devices that are used to maintain the integrity of the tank's seal and to compensate for any extreme or unplanned conditions. There are also a number of gauges and relays which are covered in chapter 9 that are used to monitor the pressure and temperature conditions inside the tank.

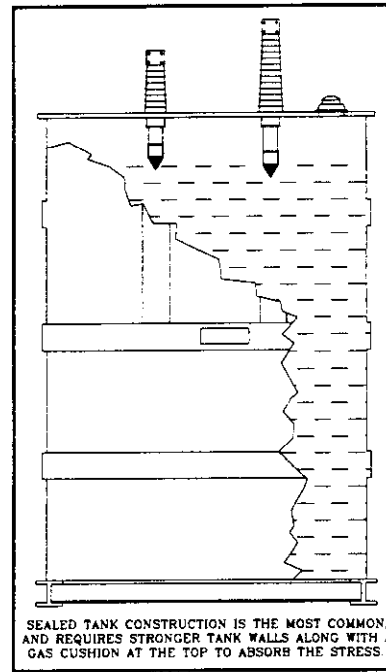

Figure 4-4. Sealed transformers.

CHAPTER 5

INSULATING FLUIDS

5-1. Oil

Although new systems are fluids are constantly being developed, mineral oil is the most common fluid in use today. Polychlorinated biphenyl (PCBs) are not acceptable to the Environmental Protection Agency (EPA) for use in transformers. Any reference to "oil" or "insulating fluid" in this section will be understood to mean transformer mineral oil. The manufacturer's instructions and guidelines should be considered when dealing with fluids.

a. Insulating fluid plays a dual function in the transformer. The fluid helps to draw the heat away from the core, keeping temperatures low and extending the life of the insulation. It also acts as a dielectric material, and intensifies the insulation strength between the windings. To keep the transformer operating properly, both of these qualities must be maintained.

b. The oil's ability to transfer the heat, or its "thermal efficiency," largely depends on its ability to flow in and around the windings. When exposed to oxygen or water, transformer oils will form sludge and acidic compounds. The sludge will raise the oil's viscosity, and form deposits on the windings. Sludge deposits restrict the flow of oil around the winding and cause the transformer to overheat. Overheating increases the rate of sludge formation (the rate doubles for every 10 °C rise) and the whole process becomes a "vicious cycle." Although the formation of sludge can usually be detected by a visual inspection, standardized American Society for Testing and Materials (ASTM) tests such as color, neutralization number, interfacial tension, and power factor can provide indications of sludge components before visible sludging actually occurs.

c. The oil's dielectric strength will be lowered any time there are contaminants. If leaks are present, water will enter the transformer and condense around the relatively cooler tank walls and on top of the oil as the transformer goes through the temperature and pressure changes caused by the varying load. Once the water condenses and enters the oil, most of it will sink to the bottom of the tank, while a small portion of it will remain suspended in the oil, where it is subjected to hydrolysis. Acids and other compounds are formed as a by-product of sludge formation and by the hydrolysis of water due to the temperature changes. Water, even in concentrations as low as 25 ppm (parts per million) can severely reduce the dielectric strength of the

oil. Two important tests for determining the insulating strength of the oil are dielectric breakdown and moisture content.

d. The two most detrimental factors for insulating fluids are heat and contamination. The best way to prevent insulating fluid deterioration is to control overloading (and the resulting temperature increase), and to prevent tank leaks. Careful inspection and documentation of the temperature and pressures level of the tank can detect these problems before they cause damage to the fluid. However, a regular sampling and testing routine is an effective tool for detecting the onset of problems before any damage is incurred.

5-2. Oil testing

ASTM has developed the standards for oil testing. The following tests are recommended for a complete analysis of a transformer's oil:

a. Dielectric breakdown (ASTM D-877 & D-1816). The dielectric breakdown is an indication of the oil's ability to withstand electrical stress. The most commonly performed test is ASTM D-877, and because of this, it is more readily used as a benchmark value when comparing different results. The oil sample is placed in a test cup and an AC voltage is impressed on it. The electrodes are two discs, exactly 1 in. in diameter and placed 0.10 in. apart. The voltage is raised at a constant rate, until an arc jumps through the oil between the two electrodes. The voltage at which the arc occurs is considered the dielectric strength of the oil. For systems over 230 kV, this test is performed using spherical electrodes spaced 0.04 or 0.08 in. apart (ASTM D-1816). Portable equipment is available for performing both levels of this test in the field.

b. Neutralization number (ASTM D-974). Acids are formed as by-products of oxidation or sludging, and are usually present any time an oil is contaminated. The concentration of acid in an oil can be determined by the amount of potassium hydroxide (KOH) needed to neutralize the acid in 1 g of oil. Although it is not a measure of the oil's electrical strength, it is an excellent indicator of the presence of contaminants. It is especially useful when its value is monitored over a number of sampling periods and trending data is developed.

c. Interfacial tension (ASTM D-971 & D-2285). The interfacial tension of an oil is the force in dynes per centimeter required to rupture the oil film existing at an oil-water interface. When certain contaminants,

such as soaps, paints, varnishes, and oxidation products are present in the oil, the film strength of the oil is weakened, thus requiring less force to rupture. For in-service oils, a decreasing value indicates the accumulation of contaminants, oxidation products, or both. ASTM D-971 uses a platinum ring to physically break the interface and measure the force required. ASTM D-2285 measures the volume of a drop of water that can be supported by the oil without breaking the interface.

d. Power factor (ASTM D-924). The power factor is an indication of the amount of energy that is lost as heat to the oil. When pure oil acts as a dielectric, very little energy is lost to the capacitance charging. Contaminants will increase the energy absorbed by the oil and wasted as heat. The power factor is a function of the phasor angle (the angular displacement) between an AC potential applied to the oil and the resulting current. The test is performed by passing a current through a test cell of known gap, and using a calibrated capacitance or resistance bridge to separate and compare the reactive and resistance portions of the current passing through the oil.

e. Color (ASTM D-1500). The color of a new oil is generally accepted as an index of refinement. For in-service oils, a darkening of the oil (higher color number), observed over a number of test intervals, is an indication of contamination or deterioration. The color of an oil is obtained by comparison to numbered standards. Although there are charts available, the most accurate way to determine the oil's color is by the use of a color wheel and a comparator. An oil sample is placed in the comparator, and the color wheel is rotated until a match is obtained. This test is most effective when results are compiled over a series of test intervals, and trending data is developed.

f. Moisture content (ASTM D-1533). Moisture content is very important in determining the serviceability of an oil; the presence of moisture (as little as 25 parts per million) will usually result in a lower dielectric strength value. Water content is especially important in transformers with fluctuating loads. As the temperature increases and decreases with the changing load, the transformer's oil can hold varying amounts of water in solution. Large amounts of water can be held in solution at higher temperatures, and in this state (dissolved) the water has a dramatic effect on the oil's performance. Water contamination should be avoided.

(1) Water content is expressed in parts per million, and although water will settle to the bottom of the tank and be visible in the sample, the presence of free water is not an indication of high water content, and it is usually harmless in this state. The dissolved water content is the dangerous factor; it is usually measured by physical or chemical means. A Karl Fischer titrating apparatus is one of the more common methods of measuring the dissolved water content.

(2) There are other tests available, such as Flashpoint, Viscosity, and Specific Gravity. They are of limited value for interpretation of the oil's quality, but can be used for further investigation if unsatisfactory results are obtained for the tests listed above.

(3) Table 5-1 lists the acceptable values for the laboratory test results for various insulating fluids.

5-3. Dissolved gas in oil analysis

The primary mechanisms for the breakdown of insulating fluids are heat and contamination. An unacceptable insulation resistance value will tell you only that the insulation's resistance is not what it should be; it is hard to draw any conclusions as to why the insulation is deteriorating. The standard ASTM tests for insulating fluids will provide information about the actual quality of the oil, but the cause of the oil's deterioration must be determined by further investigation. Detection of certain gases in an oil-filled transformer is frequently the first indication of a malfunction. Dissolved gas in oil analysis is an effective diagnostic tool for determining the problem in the transformer's operation.

a. When insulating materials deteriorate, when sludge and acid is produced, or when arcing or overheating occurs, various gases are formed. Some of these gases migrate to the air space at the top of the tank, but a significant amount is trapped, or "entrained," in the oil. By boiling off these gases and analyzing their relative concentrations with a gas chromatograph, certain conclusions can be drawn about the condition of the transformer.

b. Gases are formed in the oil when the insulation system is exposed to thermal, electrical, and mechanical stresses. These stresses lead to the following gas-producing events:

(1) *Overheating.* Even though the insulation will not char or ignite, temperatures as low as 140 °C will begin to decompose the cellulose and produce carbon dioxide and carbon monoxide. When hot spot temperatures (which can be as high as 400 °C) occur, portions of the cellulose are actually destroyed (by pyrolysis), and much larger amounts of carbon monoxide are formed.

(2) *Corona and sparking.* With voltages greater than 10 kV, sharp edges or bends in the conductors will cause high stress areas, and allow for localized low energy discharges. Corona typically produces large amounts of free hydrogen, and is often difficult to differentiate from water contamination and the resulting rusting and oxidation. When the energy levels are high enough to create a minor spark, quantities of methane, ethane and ethylene will be produced. Sparks are usually defined as discharges with a duration of under one microsecond.

(3) *Arcing.* Arcing is a prolonged high energy discharge, and produces a bright flame. It also produces a characteristic gas (acetylene), which makes it the easi-

Table 5-1. Insulating fluids: suggested test values

Laboratory Test Values				
Test	Oil	High Molecular Weight Hydrocarbon	Silicone	Tetrachloroethylene
Dielectric Breakdown ASTM D-877	30 kV Minimum	30 kV Minimum	30 kV Minimum	30 kV Minimum
Neutralization Number ASTM D-974	.04 MG-KOH/GM Maximum	.03 MG-KOH/GM Maximum	.01 MG-KOH/GM Maximum	.25 MG-KOH/GM Maximum
Interfacial Tension ASTM D-971 or D-2285	35 Dynes/cm Minimum	33 Dynes/cm Minimum	—	—
Color ASTM D-1500	1.0 Maximum	N/A Maximum	.05 (D-2129)	—
Visual Condition ASTM D-1524	Clear, Bright Pale Straw	N/A	Crystal Clear (D-2129)	Clear, Slight Pink Iridescent
Power Factor ASTM D-924 @ 25 Deg. C	0.1% Maximum	0.1% Maximum	0.1% Maximum	2% Maximum
Water Content ASTM D-1533 15 kV and below	35 PPM* Maximum	35 PPM Maximum	80 PPM Maximum	25 PPM Maximum
Above 15 kV - below 115 kV	25 PPM* Maximum	—	—	—
115 kV-230 kV	20 PPM Maximum	—	—	—
Above 230 kV	15 PPM Maximum	—	—	—
*Or in accordance with manufacturer's requirements. Some manufacturers recommend 15 PPM maximum for all transformers.				

est fault to identify. Acetylene will occur in a transformer's oil only if there is an arc.

(a) Other conditions that will cause gases to form in the transformer's oil include tank leaks, oil contamination, sludging and residual contaminants from the manufacturing and shipping processes. In most cases, the determinations that can be made are "educated guesses," but they do at least provide a direction and starting point for further investigation. Also, many of the gases can be detected long before the transformer's condition deteriorates to the point of a fault or unacceptable test results.

(b) In general, combinations of elements that occur naturally in pairs, such as hydrogen (H₂), oxygen (O₂), and nitrogen (N₂) reflect the physical condition of the transformer. Higher levels of these gases can indicate the presence of water, rust, leaky bushings, or poor seals.

(c) Carbon oxides such as CO and CO₂ reflect the demand on the transformer. High levels of each can show whether the transformer is experiencing minor

overload conditions, or if it is actually overheating.

(d) The concentrations of hydrocarbon gases, such as Acetylene, ethylene, methane and ethane indicate the integrity of the transformer's internal functions. Acetylene will be produced only by a high energy arc, and the relative concentrations of the others can indicate cellulose breakdown, corona discharge or other faults.

(e) Tables 5-2 and 5-3 show the various gases that can be detected, their limits, and the interpretations that can be made from their various concentrations.

(f) Dissolved gas in oil analysis is a relatively new science, and new methods of interpretation are constantly being devised. The Rogers Binary ratio, The Dornenberg Ratios, and the Key Gas/Total Combustible Gas methods are just a few. This type of analysis is still not an exact science (it began in the 1960s), and as its use becomes more widespread and the statistical base of results grows, the determinations will become more refined.

Table 5-2. Dissolved gas in oil analysis.

Gases			
Suggested Gas Limits in PPM for In-Use Transformers		Names and Symbols for Gases	
H ₂	100	Hydrogen	H ₂
O ₂	50,000	Oxygen	O ₂
CH ₄	120	Nitrogen	N ₂
C ₂ H ₂	35	Carbon Monoxide	CO
C ₂ H ₄	30	Carbon Dioxide	CO ₂
C ₂ H ₆	65	Methane	CH ₄
CO	350	Ethane	C ₂ H ₆
CO ₂	1000	Ethylene	C ₂ H ₄
		Acetylene	C ₂ H ₂
		Propane	C ₃ H ₈
		Propylene	C ₃ H ₆
		Butane	C ₄ H ₁₀

Below is a table showing gas combinations and their interpretations indicating what may be happening inside the operating transformers.

5-4. Transformer oil sampling

Samples can be drawn from energized transformers, although extreme caution should be observed when working around an energized unit. It is a good practice, for both energized and de-energized units, to attach an auxiliary ground jumper directly from the sample tap to the associated ground grid connection.

a. During the first year of a testing program, inspections and sampling should be conducted at increased frequencies. Baseline data must be established, and more frequent testing will make it easier to determine the rate of change of the various items. A conservative sampling interval would be taken immediately after energization, and every 6 months for the first year of a newly initiated program. Specialized applications such as tap changers and regulators should be sampled more frequently. Except for color and dielectric strength, which can be tested easily in the field, it is recommended that oil analysis be performed by a qualified laboratory.

b. Glass bottles are excellent sampling containers because glass is inert and they can be readily inspected for cleanliness before sampling. Impurities that are drawn will be visible through the glass. The bottles can be stoppered or have screw caps, but in no instance should rubber stoppers or liners be used; cork or aluminum inserts are recommended. Clean, new rectangu-

lar-shaped, 1-quart cans with screw caps and foil inserts are also good, especially when gas-in-oil analysis is to be performed. Glass bottles and cans are well suited if the sample must be shipped or stored. For standard oil testing, a small head space should be left at the top of the container to allow for this expansion and contraction. For dissolved gas in oil, the can should be filled all the way to the top to eliminate the infusion of atmospheric gases into the sample.

c. Because the usefulness of oil testing depends on the development of trending data, it is important for oil samples to be drawn under similar conditions. The temperature, humidity, and loading of the transformer should be documented for each sample, and any variations should be considered when attempting to develop trending data. Samples should never be drawn in rain or when the relative humidity exceeds 70 percent. Different sampling techniques can alter the results, and steps should be taken to ensure that all samples are drawn properly.

d. When possible, oil samples should always be drawn from the sampling valve at the bottom of the tank. Because water is heavier than oil, it will sink to the bottom and collect around the sampling valve. To get a representative sample, at least a quart should be drawn off before the actual sample is taken. If a number of samples are taken, they should be numbered by the order in which they were drawn.

Table 5-3. Troubleshooting transformers with detected gases.

Troubleshooting Chart	
Detected Gases	Interpretations
a) Nitrogen plus 5% or less oxygen	Normal operation, good seals
b) Nitrogen plus 5% or more oxygen	Check seals for tightness
c) Nitrogen, carbon dioxide, or carbon monoxide, or all	Transformer overloaded or operating hot causing some cellulose breakdown. Check operating conditions
d) Nitrogen and hydrogen	Corona, discharge, electrolysis of water, or rusting
e) Nitrogen, hydrogen, carbon dioxide and carbon monoxide corona discharge involving cellulose or severe overloading	
f) Nitrogen, hydrogen, methane with small amounts of ethane and ethylene	Sparking or other minor fault causing some breakdown of oil
g) Nitrogen, hydrogen, methane with carbon dioxide, carbon monoxide and small amounts of other hydrocarbons; acetylene is usually not present	Sparking or other minor fault causing breakdown of oil
h) Nitrogen with high hydrogen and other hydrocarbons including acetylene	High energy arc causing rapid deterioration of oil
i) Nitrogen with high hydrogen, methane, high ethylene and some acetylene	High temperature arcing of oil but in a confined area; poor connections or turn-to-turn shorts are examples same as (I) except arcing in combination with cellulose
j) same as (I) except carbon dioxide and carbon monoxide present.	

e. The sample jars should be clean and dry, and both the jars and the oil should be warmer than the surrounding air. If the transformer is to be de-energized for service, the samples should be taken as soon after de-energization as possible, to obtain the warmest oil during the sampling. The sample jars should also be thoroughly cleaned and dried in an oven; they should be kept warm and unopened until immediately before the sample is to be drawn.

5-5. Synthetics and other insulating fluids

Although there are a number of synthetic compounds available, such as silicone, trichloroethane, and various aromatic and paraffinic hydrocarbons, the most common transformer insulating fluids currently in use are mineral oil and PCBs. The use of PCB has been severely restricted recently, and special attention should be given to its maintenance and disposal.

a. *PCB (polychlorinated biphenyl)*. PCBs have been used extensively in industry for nearly 60 years. PCBs were found to be especially suited for transformer

applications because they provided excellent insulating properties and almost no fire hazards. In the 1960s, it was discovered that PCB, and especially the products of its oxidation were harmful to the environment and to the health of personnel. The USEPA began regulating PCBs in the 1980s, and although the regulations are constantly being changed and updated, prudent and conservative policies should always be applied when dealing with PCBs. PCB should not be allowed to come in contact with the skin, and breathing the vapors or the gases produced by an arc should be avoided. Safety goggles and other protective equipment should be worn when handling PCBs. Even though PCBs are no longer being produced, there are still thousands of PCB transformers in the United States alone. Transformers that contain PCBs should be marked with yellow, USEPA-approved stickers. The concentration of PCB should be noted on the sticker, and all personnel working on or around the transformer should be aware of the dangers involved. A PCB transformer should be diked to contain any spills, and all leaks should be rectified and reported as soon as possible. If the trans-

former requires addition fluid, only approved insulating fluids, such as RTemp should be mixed with the PCB. If the handling and disposal of PCB materials is required, only qualified personnel should be involved, and strict documentation of all actions should be maintained. It is recommended that only qualified professionals, trained in spill prevention and containment techniques, be permitted to work on PCB transformers.

b. Silicone. Silicone fluid is also used widely for many applications. It is nearly as fire resistant as PCB, and provides many of the same performance benefits. It is also more tolerant of heat degradation and contamination than most other fluids, and will not sludge when exposed to oxidation agents.

(1) The specific gravity of silicone, however, changes with temperature. Silicone's density varies between 0.9 and 1.1 times that of water, which causes

water to migrate from the top to the bottom of the tank as the temperature changes. This is especially detrimental in transformers that undergo large or frequent loading and temperature changes.

(2) Silicone also changes in volume more during the temperature changes and this places greater stress on the various gaskets and covers on the tank. Added pressure compensating and relief devices are usually found on silicone units.

(3) Many other types of insulating fluids are currently in use for specialized applications. Although they may have complex chemical make-ups, most of the maintenance strategies listed in this section will apply; contamination and overheating are their worst enemies. The manufacturer's instruction booklets should be referred to when working with these fluids.

CHAPTER 6

INITIAL ACCEPTANCE INSPECTION/TESTING

6-1. Acceptance

While testing and inspection programs should start with the installation of the transformer and continue throughout its life, the initial acceptance inspection, testing and start-up procedures are probably the most critical. The initial inspections, both internal and external, should reveal any missing parts or items that were damaged in transit; they should also verify that the transformer is constructed exactly as specified. The acceptance tests should reveal any manufacturing defects, indicate any internal deficiencies, and establish baseline data for future testing.

a. The start-up procedures should ensure that the transformer is properly connected, and that no latent deficiencies exist before the transformer is energized. Ensuring that the transformer starts off on “the right foot” is the best way to guarantee dependable operation throughout its service life.

b. Various manufacturers recommend a wide range of acceptance and start-up procedures. Although basic guidelines and instructions are presented here, in no case should be manufacturer’s instructions and recommendations be ignored. The intent of this manual is to present the practical reasoning behind the procedures recommended by the manufacturer. In some cases, the following procedures will exceed the manufacturer’s recommendations, and in others, the manufacturer will call for more involved and comprehensive procedures. When in doubt, consult the manufacturer’s guidelines.

6-2. Pre-arrival preparations

Before the transformer arrives, the manufacturer should be contacted to ensure that all arrangements can be completed smoothly. If possible, the start-up literature or owner’s manuals should be provided by the manufacturer before the transformer arrives, so that preparations can be made.

a. Dimensions and lifting weights should be available to ensure that the transformer can be easily moved and positioned. If at the possible, the transformer should be moved to its final installation point immediately on arrival. If the transformer must be stored before energization, steps should be taken to see that the area where it is stored is fairly clean and not exposed to any severe conditions. Regular inspections and complete documentation should be maintained for the transformer while it is stored. Manufacturers will prescribe completely different start-up procedures, depending on

how long and in what type of environment a transformer has been stored.

b. The equipment necessary for start-up should be assembled after the site preparations have been completed, and all receiving and unloading arrangements have been made. The following equipment may be necessary depending on the type of transformer, how it is shipped, and its condition on arrival.

(1) *Lifting/moving equipment.* If the transformer must be moved, it should be lifted or jacked only at the prescribed points. Most transformer tanks are equipped with lifting eyes, but if they are shipped with their bushings or radiators in place, they will require special slings and spreaders to prevent the equipment from being damaged. Also, it is important to remember to never use the radiators, bushings, or any other auxiliary equipment to lift or move the transformer or to support a person’s weight. Having the proper equipment on site will expedite the unloading and placement of the transformer.

(2) *Test equipment.* Depending on the start-up procedure, any of the following items may be required: A megohmmeter (“megger”) insulation resistance test set, transformer turns ratio test set, power factor test set, liquid dielectric test set, dew point analyzer, oxygen content analyzer, and various thermometers and pressure gauges. Sample jars should also be available, and samples should be taken both before and after oil-filling operations.

(3) *Vacuum and filtering equipment.* Even if the oil being used has good dielectric strength, a good filter will remove any entrained water or contaminants introduced during the filling process. Most transformer oils require a 5-micron filter media. The capacity of the vacuum pump will depend on the physical size and voltage rating of the transformer. Larger tanks may require a pump capable of 200 cfm, and transformers with voltages above 69 kV may require a sustained pressure/vacuum level of 2-50 Torr (one torr is a unit of very low pressure, equal to 1/760 of an atmosphere). The blank off pressure (the minimum pressure the pump can attain at the inlet) and CFM ratings are usually provided on the pump’s nameplate. An assortment of pipe and fittings should also be available to make the necessary connections. An assortment of caps, plugs, and valves should also be available for blanking off any equipment that could be damaged by the vacuum.

(4) *Gas cylinders.* Nitrogen will be needed for

applying the gas blanket and breaking the vacuum. Dry air will be needed if the tank must be entered for inspection or equipment installation. As a safety precaution, bottled pure oxygen must be available anytime anyone enters the tank.

(5) *Safety equipment.* At least two 20-pound CO₂ extinguishers must be available for internal or external use. One 20-pound dry powder extinguisher should be available for use on the exterior of the transformer. All personnel should be thoroughly trained and capable of implementing fire-fighting, spill containment, first aid, and other emergency procedures.

(6) *Miscellaneous equipment.* A camera should be available to document any discrepancies that are found during the receiving or internal inspections. Large tents or enclosures will be required if the transformer must be opened or filled in inclement weather. Ladders or scaffolding will be necessary depending on the size of the transformer. Explosion-proof lamps enclosed in a fine stainless steel mesh will be required to provide light inside the tank. Drop cloths or plastic sheets should be used to prevent material from dropping into the tank or winding assembly. All tools or materials that enter the tank must be accounted for; it is a good idea to attach strings to any small objects that enter the tank.

6-3. Receiving and inspection

When the transformer arrives, all paperwork should be checked to ensure that the transformer is constructed and equipped exactly as specified. Parts lists should be checked and all parts should be counted to ensure that nothing has been omitted. Any auxiliary equipment or shipping crates should be inspected for evidence of damage. Careful attention should also be paid to moisture barriers or waterproof wrappings; if they are torn or damaged, the equipment inside may need to be dried out.

a. The external inspection should be completed before the transformer is unloaded, and, if major problems are discovered, an internal inspection should be conducted. External inspection should verify the following:

- (1) Tie rods and chains are undamaged and tight.
- (2) Blocking and bracing are tight.
- (3) There is no evidence of load shifting in transit.
- (4) If there is an impact recorder, whether it indicates any severe shocks.
- (5) Whether there are indications of external damage, such as broken glass or loose material.
- (6) Whether there are any obvious dents or scratches in the tank wall or auxiliary compartments.
- (7) Whether there is evidence of oil leakage.
- (8) Whether there is positive pressure or vacuum in the tank.
- (9) Whether porcelain items have been chipped or bent at their mounting flanges.

b. If any of the above items are noted, it should be

clearly marked on the delivery receipts, and the manufacturer should be contacted. If an internal inspection is required, the manufacturer's and or carrier's representatives may need to be present.

6-4. Moving and storage

If at all possible, the internal inspection should be conducted before the transformer is unloaded. If the transformer must be unloaded for an internal inspection, it should be moved directly to the point of installation.

a. When unloading the transformer or placing it in position, be sure to use the designated lifting eyes or jacking points. The transformer should be handled in the normal upright position, and in no case should it be tilted more than 15 degrees. Spreaders should be used to hold the lifting cables apart, particularly if they are short and may bear against external assemblies or bushings. Do not attempt to lift or drag the transformer by placing a loop or sling around it, and do not use radiators, bushings, or other auxiliary equipment for climbing or to lift the transformer. Transformers are extremely dense and heavy, much heavier than circuit breakers or other switchgear items. A conservative safety factor should always be applied when a transformer must be lifted.

b. An internal inspection is called for if there is evidence of damage, or if the transformer is to be stored. When the unit is to be stored for more than 3 months, it should be protected from the weather. All scratches or paint defects should be touched up before storage. If the transformer is filled with oil, it should be tightly sealed so that no moisture or air can enter the case. If the transformer is shipped filled with inert gas, periodic inspection should determine that a positive pressure of about 2 psi is maintained at all times. Water-cooled transformers should have the water-cooling coils filled with alcohol or other similar antifreeze to eliminate any danger of freezing or contamination.

c. Regular inspection and documentation procedures should be conducted during transformer storage. All inspection and service procedures should be thoroughly documented, and any discrepancies or adverse conditions should be noted. Pumps and fans should be operated for 30 minutes, once a month. At the end of the storage period, oil samples should be drawn and analyzed for dielectric strength, power factor, and water content. Insulation resistance and power factor tests should be conducted on the transformer and compared to the original factory data.

d. Larger transformers are often shipped without oil. They are vacuum filled with hot oil at the factory to impregnate the winding insulation with oil. The oil is then removed for shipping. This oil impregnation is vital to the winding's insulation strength, and will be lost if the transformer is stored for too long without oil. Most manufacturers recommend a maximum storage time of 3 months without oil. If this storage time is exceeded,

hot oil vacuum degasification must be performed, and the manufacturer's guidelines should be followed.

6-5. Internal inspection

If an internal inspection is called for, or if the transformer must be opened to install bushings and other auxiliary equipment, two factors should be of primary importance: (1) to make every attempt to minimize the time the transformer is opened; (2) to take whatever measures necessary to ensure that no moisture, foreign material, or other contaminants enter the tank.

a. The time element can be minimized by assembling all necessary tools and materials before the tank is opened. Personnel conducting the inspection/assembly should review all procedures and be prepared to complete their work as quickly as possible. They should also be prepared to implement any fire fighting or emergency procedures. If the tank must be entered, all personal should empty their pockets and ensure that no loose debris is in their pant cuffs or on their shoes. Approved shoe coverings should be worn by anyone who will be on top or inside the transformer. It is also good idea to use drop cloths under all internal work where practical, and to inventory and tie-off all tools being used. One person should be responsible for policing the people and materials into and out of the transformer, and for making certain nothing is left in the transformer.

b. Transformers are capable of stepping harmless voltages up to dangerous levels. This applies to both low level test potentials, and to static charges built up between equipment, windings, tank walls, and personnel. This danger is further complicated by the flammability of transformer oil. All windings, bushings, pumps, pipes, filter equipment and external connections should be solidly grounded during the inspection, testing, and assembly procedures. Grounds should also be applied to any component of the transformer immediately after a test potential is applied to the component.

c. Transformer tanks are usually pressurized with dry nitrogen for shipping. The pressure must be broken slowly and dry air must be introduced; an oxygen content of 20 to 25 percent should be confirmed before entering the tank. It is important to remember that tank pressures as low as 1 psi will blow covers and fittings off as they are being removed. Ensure that all tank and compartment pressures have been equalized before opening the tank.

d. After the tank pressure has been equalized, and the proper oxygen content has been verified, the temperature of the core and coils should be measured. The tank should not be opened unless the temperature of the internal portion of the transformer is at least 2°F above the dew point of the outside air. The dew point is a measure of the ability of the surrounding air to allow moisture to condense on the transformer's surfaces.

e. Dew point measurements of transformers shipped

without oil can be made with a number of different instruments. The Alnor Model 7300 is commonly used for transformer start up. Dew point testers operate on the principle that moisture in a gas will precipitate or "fog" in a definite relationship to the temperature and the degree of moisture in the air. By ascertaining that the outside air is low enough in moisture content, and that the temperature of the transformer's components is high enough, the possibility of introducing unwanted moisture into the transformer can be nearly eliminated.

f. Tents and heated temporary enclosures can be used to provide a controlled environment if the work must be completed in inclement weather. Even if the external conditions are satisfactory, it is a good idea to blow a pressurized stream of bottled dry air through the tank while it is open. Creating a slight positive pressure will prevent outside air from entering the tank.

g. If the transformer is shipped filled with oil, the internal inspection can be conducted by lowering the oil level to just above the windings. This can usually be accomplished by installing the radiators and allowing the oil to flow into them. Be certain radiators have been cleaned and pressure checked before installing, and gaskets and valves are installed correctly. An explosion proof spotlight with an oil resistant cord can be lowered into the tank to conduct the inspection.

h. If the oil must be lowered below the windings, and the windings are exposed for more than 24 hours, all of the oil should be removed and the transformer refilled using hot vacuum degassing techniques. Because the equipment required for hot vacuum degassing is rather involved and costly, it is recommended that the manufacturer or qualified professional be present for the operation.

i. The objective of the internal inspection is to locate any damage that may have occurred during shipment. Examine the top of the core and coil assembly, all horizontal surfaces, and especially the underside of the cover for signs of moisture. All leads, bolted mechanical and electrical joints, current transformers and insulation structures should be thoroughly inspected. The tap changer should be exercised, and all connections verified. Terminal boards should be checked to see that connections are as specified.

j. Although most testing should be performed only while the coils are submerged in oil, if the inspection is being conducted because of problems noted during the external or internal inspections, the following tests should be conducted:

(1) Power factor tests for all winding to ground and windings to winding values.

(2) Turns ratio tests for all windings and tap positions.

(3) Ratio and polarity tests for all current transformers.

(4) Winding resistance checks for all primary and secondary windings.

(5) Discount the grounding connections between the core assembly and the tank, and perform insulation resistance tests with a megger.

k. These test values should be compared to the factory supplied test data. All temperature and humidity readings should be recorded to facilitate this comparison.

6-6. Testing for leaks

If the test results indicate a moisture or contamination problem with the transformer, if the gauges register zero pressure on arrival, or if moisture is discovered during the internal inspection, the transformer should be tested for leaks before final vacuum filling begins.

a. Most transformers are pressurized to approximately 3 psi for shipping. It is important to remember that this pressure will fluctuate according to temperature; a zero pressure gauge reading is not a sure sign of a leak. If the pressure registers zero in the sunlight and at nighttime (over a range of more than 10 °F), then a leak can be suspected.

b. Leaks can be detected by applying a positive pressure to the tank. All bushings, radiators, gauges and auxiliary equipment should be installed before a leak check is conducted. Some items may need to be blanked off for the pressure check, and the pressure should be raised slowly so as not to damage the sudden pressure relay or any other sensing devices. Verify the maximum pressure capabilities of the tank (usually found on the nameplate or in the shipping specifications) and use bottled nitrogen to apply the pressure, being careful to always stay at least 1 psi below the maximum allowable. If the tank is empty, a soap/glycerin solution should be applied to all seams, gaskets and fittings. Bubbling and sputtering noises will indicate the location of the leak. If the tank is filled with oil, the soap solution should be applied above the oil level, and chalk dust applied below the oil level. Chalk dust will darken noticeably where any oil is seeping out.

c. Small leaks at seams and welds can be carefully hammered shut with a ball peen hammer, although larger ones may require welding or epoxy patching. Leaking gaskets should be replaced, and fittings can usually be removed and resealed using glyptal, Teflon tape, or other sealing compounds. The manufacturer should be contacted to ensure the use of proper compounds. Vacuum filling operations can begin once the leads have been replaced and the interior of the transformer has been determined to be dry.

d. The core and coils may need to be dried if a major leak was found, if the transformer has been opened for an extended period, or if unsatisfactory test results were obtained for any of the preliminary testing. Drying the transformer is an involved and potentially damaging process; effective drying of the core insulation requires temperatures in excess of 90 °C. Manufacturers recommend a variety of procedures for

drying and determining when the transformer is sufficiently dry. The manufacturer should be contacted if excessive moisture is suspected.

6-7. Vacuum filling

New oil can contain enough contaminants to cause a fault when the transformer is first energized. The presence of small quantities of contaminants will begin on ongoing degradation of the oil's quality. The quality of transformer oil depends on its purity; many factors in shipping and storage cannot be controlled once the oil leaves the refinery. The most effective way to ensure that no impurities are introduced into the oil is to filter the oil and fill the tank under vacuum. Filtering will remove any entrained water or other contaminants, and as the stream of oil hits the vacuum, most small bubbles will be drawn out of the liquid and "explode" as they equalize with the vacuum condition in the tank.

a. Oil should be tested before it is introduced into the transformer. This should include field testing for dielectric, and drawing samples for laboratory analysis. If problems are encountered later, the results of this testing can provide valuable information for determining why and how problems are occurring. Testing also provides a good indication of how effective the filtering and vacuum operations were.

b. Before vacuum filling operations can begin, it is important to determine the maximum vacuum level the tank can withstand, and to ensure that any auxiliary devices can also withstand the same vacuum level. Items such as conservator tanks and compartment dividers will not be capable of withstanding the full vacuum applied to the tank. Additional pipe and fittings must be used to valve off or equalize the pressure that will be created by the vacuum. Other items, such as dehydrating breathers and pressure vacuum bleeders will have to be removed or valved off. It is important to consult the manufacturer's literature on these devices before applying the vacuum.

c. It is also important to remember that the tank will deflect according to the varying pressures. All rigid connections to the tank, except at the base, should be disconnected before applying the vacuum. This is especially true for bushings, lightning arresters, and other porcelain equipment.

d. Once the necessary preparations have been made, the vacuum/filtering apparatus should be connected as shown in figure 6-1.

e. When hooking up the equipment and applying the vacuum, the following conditions should be observed:

(1) All pipe connections from the pump to the transformer tank should be as short and as large in diameter as possible.

(2) All transformer leads, pumps, and bushings should be grounded to prevent the build-up of static charge.

(3) The vacuum gauge should be installed on the top of the tank itself, and not on any of the vacuum

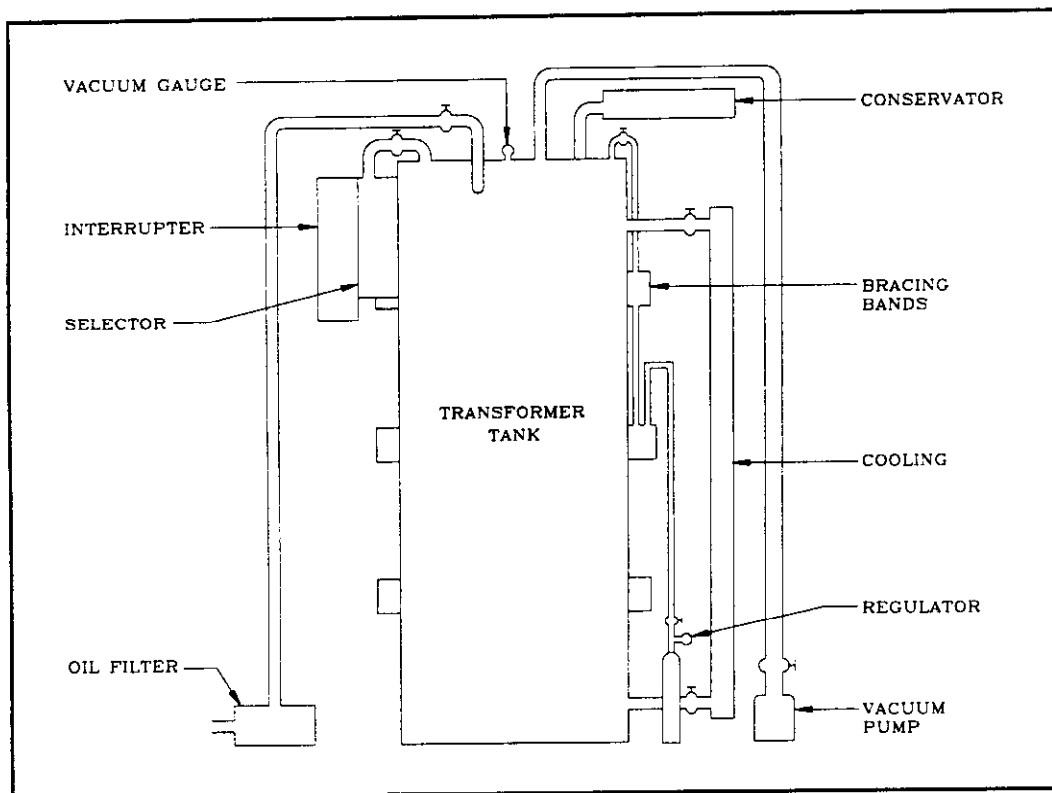

Figure 6-1. Transformer tank with vacuum filling.

lines. Use an aneroid or thermocouple gauge; the use of mercury gauges is recommended only if provisions are made to contain the mercury in the event that the gauge is broken.

(4) The oil inlet should be positioned so that oil will not enter the vacuum pump. A liquid trap should be installed in the vacuum lines to protect the pump from the oil.

(5) The flow of oil should be controlled so that oil cannot enter the sudden pressure relay or other auxiliary equipment.

(6) All valves to radiators and heat exchangers should be open.

f. Once the equipment has been assembled, make certain that enough oil is on site to complete the job without stopping. During the vacuum and liquid-filling operations, the temperature of the core and coils must be above 0 °C. The oil temperature should be at least 2 °C higher, but in no case less than 10 °C. The length of time and the magnitude of the vacuum will depend on a number of factors, including the size of the tank, the length of time the tank was opened, and the voltage rating of the transformer. The individual manufacturer's recommendations should be consulted, and the following times should be considered as minimums:

(1) Apply the vacuum for at least 3 hours before oil-filling begins.

(2) Never allow the vacuum to fall below 80 percent of the original level while pumping the oil in.

(3) Maintain the vacuum for at least 3 hours after the transformer is full.

g. While the vacuum is being applied, the transformer is especially susceptible to contamination by outside factors. There should be no leaks in the tank, hoses, or any of the auxiliary equipment, and the entire set-up should be protected from rain or moisture.

h. When the tank has been filled to the proper level, the vacuum should be broken slowly with nitrogen and pressurized to 3 psi. Once the pressurized nitrogen is applied, the cooling pumps should be operated for at least 1 hour to reduce the possibility of trapped residual gas. The transformer should then be allowed to stand without load for at least 12 hours before any tests are performed.

i. After the 12-hour standing period, the following tests should be performed to establish baseline data for the transformer.

(1) *Transformer turns ratio.* This test ensure that no material or tools are shorting the windings.

(2) *Insulation resistance-dielectric absorption.* This test is used to determine whether any grounds have been left on the windings, and whether the insulation quality is strong enough for energization.

(3) *Winding continuity resistance test.* This test should be compared to the factory supplied readings; a reading that is ore than 10 percent higher could indicate loose internal connections.

(4) *Power factor test.* This test will indicate the quality of the combined insulating fluid and winding insulation. It will also provide important baseline data for future testing. Values in excess of 1 percent could

indicate dampness in the transformer. Consult the manufacturer's instructions for drying procedures.

(5) *Insulating fluid testing.* This test will help to provide additional information if any discrepancies are noted in the above testing. Samples should be drawn for the complete series of lab tests, including dissolved gas, and dielectric strength field testing. The dielectric strength for new oil should be at least 35 kV.

j. After the testing is completed, the transformer should be energized for at least 12 hours before applying the load. Because very high currents can be developed when the transformer is first energized, any upstream fuses or fused devices should be checked immediately after the power is applied. If a fuse should blow, and if the transformer is allowed to operate without one or two fuses, it could be damaged, even if no load is applied.

k. After 12 hours, the load should be applied slowly, and the transformer should be carefully monitored as the load is being applied. Even though satisfactory test results have been obtained, personnel should stay clear of the transformer during the first 24 hours of energization. It is during this time that any entrapped air will come to the surface, and the possibility of a fault or a short should always be considered.

l. All of the acceptance test data should be recorded and used as baseline data for future testing. It is a good idea to keep copies of all test data, start-up documentation, and product information in a file cabinet with all of the other electrical system documents. The proper documentation, storage and accessibility of all product information, tests and procedures is one of the most important factors in a comprehensive and effective maintenance program.

CHAPTER 7

TRANSFORMER TESTING

7-1. Test data

Electrical performance testing is one of the most important components of a comprehensive maintenance program. Test data, when taken under, or corrected to, standard conditions, will yield valuable data about the rate of deterioration of a piece of electrical equipment. Once this rate is determined, service factors can be adjusted, and potential problems alleviated.

a. Almost all electrical failures, in all sorts of electrical equipment, can be traced to a failure of the insulation. Periodic testing will indicate the condition of the insulation at the time of the test, but does little to show the actual amount of deterioration the insulation has undergone during its service life. Only by establishing baseline data and performing regular tests under controlled conditions can trending data be developed to yield true indications of the insulation's condition.

b. Insulating fluids analysis is probably the most practical and indicative test of a transformer's condition. It provides the opportunity to actually remove a portion of the transformer's insulation and subject it to a series of standardized tests under controlled laboratory conditions, with the benefit of complex laboratory equipment. One of the most important links in the effectiveness of insulating fluids testing is the quality of the sample.

c. Except for sampling and inspection, all transformer tests should be performed on de-energized equipment. Even for sampling and inspections, the tank ground should be verified before coming into contact with any of the transformer's outer surfaces. The tests listed in this chapter and in chapter 10 should be performed only after the circuits are de-energized and checked both at the source and at the test location. See the safety procedures in chapter 1.

d. One of the most important factors in conducting transformer tests is the condition of the unit under test. A thorough inspection of the unit should be performed before the test, and any questionable conditions should be noted on an inspection record. All temperature and pressure readings should be recorded along with the atmospheric conditions (temperature and humidity) at the time of the test.

e. Test procedures should be as similar as possible from one test to another. All connections, test voltages and time intervals should be repeated exactly for each test cycle. By performing the tests in a set method, and correcting all test results to a standard temperature

value (20 °C), the data for different test intervals can be compared to indicate the rate of deterioration of the transformer.

7-2. Direct current testing

Transformer tests can be divided into two categories, alternating current (AC) and direct current (DC). Direct current testing is widely accepted because of the portability of the equipment and because of the *nondestructive nature of the tests*. Because the test potential can be applied without the reactive component (capacitive and inductive charging and recharging), DC tests can be performed at higher levels without stressing the insulation to the same degree as an AC test. It is important to note that, even though a winding failure may result, it probably resulted from an incipient condition that the test was designed to detect. If the deficiency had gone undetected, the failure may have occurred at an unplanned time and resulted in additional equipment damage.

a. When a DC potential is applied across an insulation, there are three components to the resulting current. An understanding of the nature of these currents will help with the application of the tests and the interpretation of the resulting data.

(1) *Capacitance charging current.* When the insulation resistance is being measured between two conductors, the conductors act like the plates in a capacitor. These "plates" absorb a certain amount of electrical energy (the charging current) before the applied voltage is actually developed across them. This current results in stored energy that should be discharged after the test by shorting across the insulation.

(2) *Dielectric absorption current.* As noted above, the two conductors between which the potential is being applied act like a capacitor. The winding insulation and the insulating fluid then act as dielectric materials and absorb electrical energy as their molecules become polarized, or charged. The absorption current decreases as the materials become charged, resulting in an apparent increase in the insulation resistance. The absorption current results in stored energy that takes longer to dissipate than it did to build. The insulation should be shorted for a time period equal to or longer than the time the test was applied, preferably longer.

(3) *Leakage current.* This is the current that actually flows throughout the insulation or across its sur-

face. Its magnitude is usually very small in relation to the rated current of the device, and it is usually expressed in microamperes (one millionth of an amp). It indicates the insulation's actual conductivity, and should be constant for a steady applied voltage. Leakage current that increases with time for a constant applied voltage indicates a potential problem.

b. The following tests are designed to provide indications of the transformer's condition and suitability for service. The recommended frequency and relationship in a comprehensive maintenance/testing program is discussed in chapter 10.

(1) Insulation resistance-dielectric absorption testing. The insulation resistance test is probably the best known and most often used electrical test for insulation. It is used primarily to detect low resistance paths to ground or between windings that result from carbonization, deterioration, or the presence of moisture or dirt. It will not indicate the actual quality of the insulation, but when conducted under controlled conditions, with the data compiled for a number of service intervals, trending data can be developed, and definite conclusions can be drawn as to the insulation's rate of deterioration.

(a) High and medium voltage insulation systems are usually designed to withstand large potentials and large quantities of electricity. Because of this, special equipment must be used to perform resistance tests. Ohm's Law applies for all systems, and no matter how high the applied voltage, or how "resistance" the insulating material, there will be a measurable leakage current, and there will be a resultant resistance value. Because of these conditions, leakage currents are usually stated in micro-amps (one millionth of an amp) and resistance values in megohms (one million Ohms). Most hand-held meters are not capable of reading these extremes accurately, and special equipment is used. Even if a unit can read these extremes accurately, it must also be able to supply the necessary quantities of electricity to charge the massive conductors and contacts found in a transformer.

(b) An insulation resistance test is usually performed with a megger, an instrument that is not only capable of reading high resistance values, but is also able to produce the necessary currents and voltages to obtain the readings. Megger test potentials are usually applied at 500, 1,000, 2,500, and 5,000 volts DC. These potentials are obtained by using a motor driven or hand-crank operated magneto. The hand crank units are both lightweight and portable, and because they require no batteries or external source, they are also extremely dependable. Motor-driven units, on the other hand, are capable of achieving higher and more constant test voltages, but are practically useless without batteries or an external source. Both units are available in models capable of producing accurate readings for resistance levels as high as 100,000 megohms.

(c) The following conditions should be observed when performing an insulation resistance test: Make sure that both the tank and core iron are solidly grounded. Disconnect any systems that may be connected to the transformer winding, including high and low voltage and neutral connections, lightning arrestors, fan systems, meters, and potential transformers. Potential transformers are often located on the line sides of breakers or disconnects; when the disconnect is opened, there will still be a path available to ground. Short circuit all high and low voltage windings together at the bushings connections; jumpers should be installed to ground, and no winding should be left floating. The ground connection on grounded windings must be removed. If the ground cannot be conveniently removed, the test cannot be performed on that winding. Such a winding must be treated as part of the grounded circuit.

(d) Using a megohmmeter with a minimum scale of 20,000 megohms, measure the insulation resistance across the connections as shown in figure 7-1.

(e) The terminal markings are referenced as follows: The L terminal is the line or "Hot" terminal of the instrument, where the test potential is generated. The E terminal is the "Earth" or ground connection. The G terminal is the "Guard" terminal; it is used to isolate a certain portion of the circuit from the test.

(f) These test connections are considered the bare minimum for a maintenance testing cycle, and should be applied only to a transformer that has already been in service. They will not detect shorts between the individual windings on the high or low side. For acceptance testing, or for investigative purposes, the tests diagramed in figure 7-7 can be applied.

(g) The test voltages should be as close as possible to the voltage rating of the component to which it is being applied. Suggested test voltages are found in table 7-1.

(h) All final insulation resistance values should be corrected to 20 °C to compensate for varying conditions at the time of the test, and to allow for comparison of readings taken at different test intervals. The winding temperature, and not the atmospheric temperature, should be used for insulation resistance tests. It is important to note that when a transformer is de-energized, there is a proportional change between the actual temperature of the windings and the exterior tank or oil temperature indicated by the temperature gauges. Average readings should be taken for various points on the transformer tank, and then the insulation resistance readings corrected to 20 °C. This is accomplished by applying the conversion factors in table 7-2.

(i) There are many schools of thought as to what is considered an acceptable insulation resistance value. A widely accepted rule of thumb for insulation resistance values is "the kV rating of the item under test plus one megohm." This should be considered as a bare min-

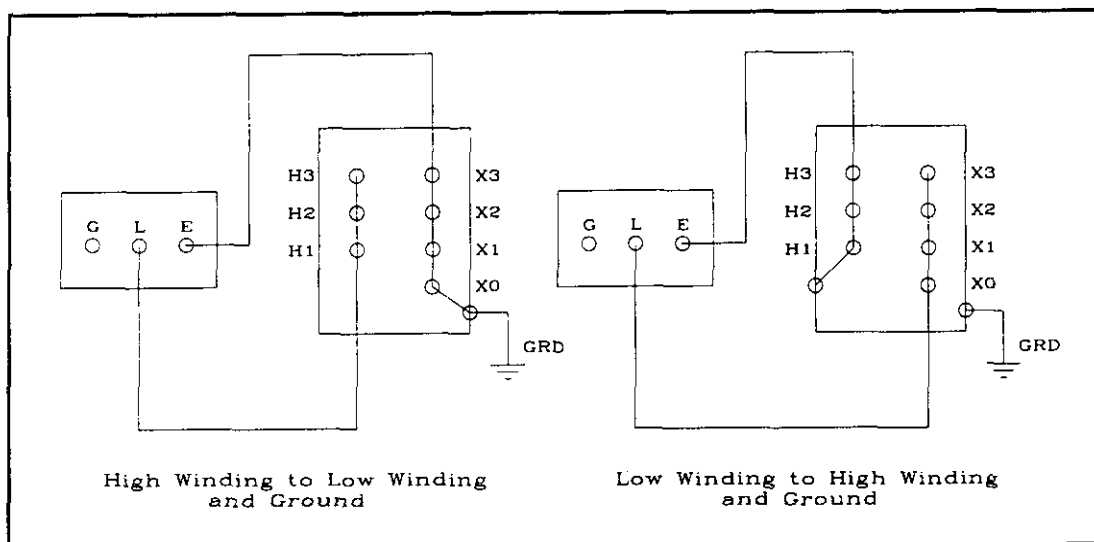

Figure 7-1. Transformer maintenance test diagram.

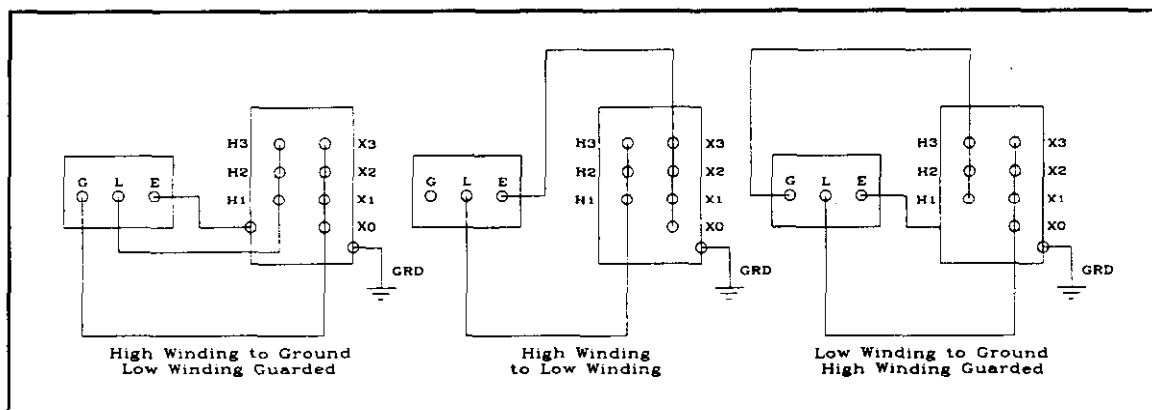

Figure 7-2. Transformer acceptance test diagram.

imum value, and any values equal to five times this amount should be investigated. If the investigation reveals nothing, then the humidity and condition of the item under test should be considered. A 10 megohm resistance value for a piece of 5 kV equipment should not be accepted without investigation, but if the humidity is high, and the insulation is dirty, that value may be acceptable.

(j) The final criterion for evaluating insulation resistance values should be the amount of change from the manufacturer's factory test values, or from the last test interval. The manufacturer should be contacted if any values are significantly lower than the factory values.

(k) To obtain useful data that is indicative of the dielectric capabilities of the transformer's insulation, it is recommended that a polarization index or dielectric absorption ratio be computed for all resistance readings. The polarization index is determined by holding the applied voltage of the megohmmeter constant, and

taking resistance readings at the end of 1- and 10-minute intervals. The apparent increase in the resistance is due to the dielectric charging of the insulation. The polarization index is computed by dividing the 10-minute value into 1-minute value.

(1) The dielectric absorption ratio is computed in the same way, except that 60-second intervals are used. These values should, theoretically, be independent of temperature or other outside factors.

(m) The polarization index and dielectric absorption ratios are also subject to different methods of interpretation. In any case, they should always be greater than one, and any downward trend in their value over a number of test intervals indicates deterioration that should be investigated.

(2) Winding resistance measurements. If a measurement of the winding resistance shows no appreciable change from the factory test values, then it can be assumed that there are no loose connections. Maintenance testing should include only the applied

tap position. Three-phase wye windings should be measured phase to neutral, and delta windings should be separated to read individual windings, if possible. If the windings cannot be separated, three separate readings should be taken, with each winding measured in parallel with the other two, and the results evaluated as a function of the parallel and series connections involved. In this instance, the comparison of the three readings (the difference should be no greater than 1 percent) will indicate whether or not there are any problems.

(a) The winding resistance can be measured with a low resistance ohmmeter, or with a Kelvin bridge. Be sure to make good contact with the winding leads, and to wait 3 minutes after initial contact before taking a reading. This delay is necessary due to the induction created by the transformer windings. Because the windings will store energy, it is important to shut off the test set and allow the energy to dissipate before removing the test leads.

(b) If the factory test values are available, or if the transformer cannot be disconnected, the resistance values for each winding should be compared to those of the adjacent windings. A difference of one percent indicates a potential problem.

(3) Contact resistance. Loose connections can result in overheating and possible equipment failure. All high and low voltage and ground connections should be inspected, and if any abnormal conditions are noted, the contact resistance should be measured to ensure that solid contact is being made. This testing works especially well in conjunction with infrared scanning. If a connection shows hot on the IR scan, and its contact resistance cannot be lowered by tightening, it should be replaced.

(4) DC high potential testing. The DC high potential test is applied at above the rated voltage, and can cause damage to the transformer if special precautions are not taken. When a leakage current passes through the insulation system of an oil-filled transformer, different amounts of the total voltage are dropped in the solid (paper) and liquid (oil) parts of the insulation. These voltage drops are caused by the resistance of each insulating component, and heat is created. Under normal AC operation, only a small amount (1/4) is dropped across the solid insulation. The remaining 3/4 is dropped in the oil, where the heat can be easily dissipated, and little harm is done.

(a) When a DC potential is applied, nearly 3/4 of the voltage is dropped across the solid insulation. This changing stress is further complicated when higher than operating level voltages are applied. DC Overpotential testing is of little value as a maintenance test, and is usually conducted for acceptance purposes, or after repair of transformers. In any event, high potential testing should not be conducted unless a satisfactory result is obtained for the insulation resistance. It is

highly recommended that the manufacturer be contacted before performing this test, and that only manufacturer's procedures be followed in conducting this test.

(b) DC Step Voltage Testing is often performed on transformers at less than the rated voltage of the winding under test. Voltages are applied in equal increments at timed intervals (usually 1 minute) and the rate of change of the leakage currents is monitored. When the applied potential is plotted against the leakage currents (on Log-Log paper) the rate of change should yield a reasonably linear slope. Leakage current jumps of more than 100-150 percent times the previous value usually indicate a problem, and the test should be discontinued so that the circuit can be investigated. Like all of the other tests, this test is especially useful when repeated tests over extended time intervals are considered, and trending data is generated.

7-3. Alternating current testing

AC testing is especially valuable when the transformer's reactive capabilities are to be measured. For maintenance testing, this includes power factor testing (measuring the capacitive quality of the insulation system) and turns ratio testing (measuring the inductance that links the primary and secondary). Although AC testing requires more energy to perform at the rated frequency, and larger test sets are involved to reach the same operating levels as DC, AC testing more closely simulates the operating condition of the transformer. The following tests are recommended for regularly scheduled maintenance:

a. Transformer turns ratio. The transformer turns ratio (TTR) test is used to determine, to a high degree of accuracy, the ratio between the primary and secondary of the transformer. This test is used to verify nameplate ratio, polarity, and tap changer operation for both acceptance and maintenance testing. It can also be used as an investigative tool to check for shorted turns or open windings. If the turn to turn insulation begins to break down in either winding, it will show up in successive TTR tests.

(1) Although there are a number of methods available, the most accurate method is by the use of a null balance test set. The ratio determined by the test set should agree with the indicated nameplate voltage ratio, within a tolerance of ± 0.5 percent.

(a) If a high exciting current is developed at low voltage, it could indicate a short in the windings or an unwanted short across the exciting clamps.

(b) If there is a normal exciting current and voltage, but not galvanometer deflection, there is the possibility of an open circuit or a lack of contact at the test leads.

(c) Actual test results for most transformers will show a slight ratio difference for the different legs of the core, due to the different return paths for the induced magnetic flux.

(2) The transformer ratio can also be computed by applying a voltage to the primary, and using two volt meters to read the voltage applied to the primary and the voltage induced in the secondary. This method depends on the combined accuracies of both volt meters, and is usually accurate to only about 1 percent.

b. Insulation power factor. Insulation power factor is similar to system power factor, in that it is a ratio of the reactive and resistance components (apparent and real power) of the applied potential. However, where it is desirable to have a system power factor as close as possible to one (purely resistance), an insulation's power factor is expected to be as near zero (purely capacitive) as possible. Insulation power factor is more akin to the dissipation factor that is used as a criterion to evaluate the efficiency of capacitors. The transformer's insulation is expected to perform as a capacitor.

(1) Any time two conductors are at different potentials, there is a capacitance between them. There is a capacitance between the individual windings, and between each winding and the tank in a transformer. The oil and cellulose insulation that separate the windings from each other and from the tank act as dielectric materials when an alternating current is applied. Uncontaminated oil and winding insulation are excellent dielectric materials, and will consume little energy in the capacitive charging and discharging that occurs in an AC system. This charging current is expressed in volt amperes, and under ideal conditions, is completely returned to the system in each full cycle. Figure 7-3 illustrates this relationship.

(2) The capacitive nature of the insulation changes as the oil becomes contaminated. Contaminants consume energy in the charge/discharge cycle, and this energy is lost as heat. Because this power is consumed and dissipated as heat, it appears as a resistive component, and can be expressed in watts. The diagram in figure 7-3 is modified in figure 7-4 to show this resistive component.

Power factor testing is performed by measuring the total volt-amperes drawn by the system. A capacitance bridge, resistance bridge, or combination of volt, amp, and watt meters is used to separate the resistance and reactive components. The power factor is then expressed as a ratio of the resistive energy that is consumed as heat (watts), to the apparent (vector sum of reactive and resistance) energy that flows into the system (volt-amperes). Figure 7-5 shows a typical metering system for measuring power factor. The power factor can also be expressed as a function (the cosine) of the phase angle between the applied voltage and the resulting current. If the insulation was purely resistive, the current would occur at exactly the same time as the voltage was applied (the phase angle, or displacement, between the current and the voltage would be zero). The cosine of 0° is one, representing a 100 percent power factor.

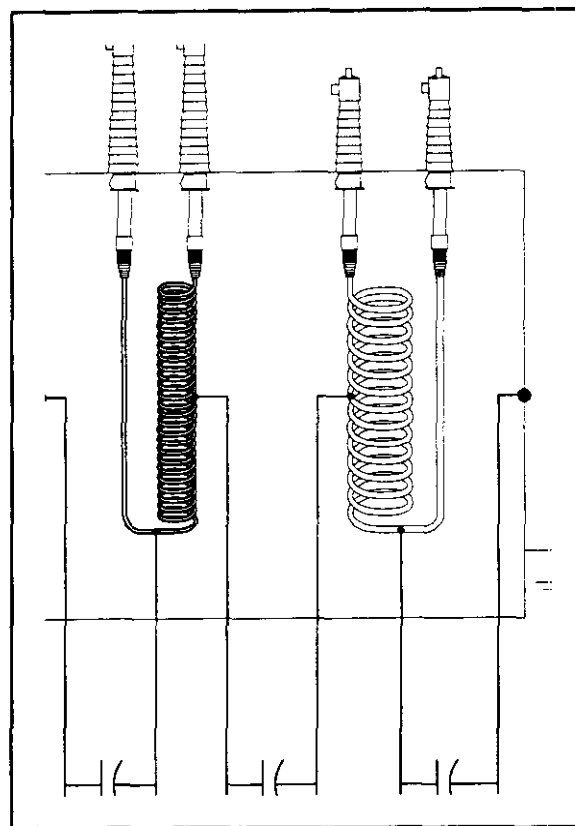

Figure 7-3. Winding losses in a transformer with uncontaminated dielectric.

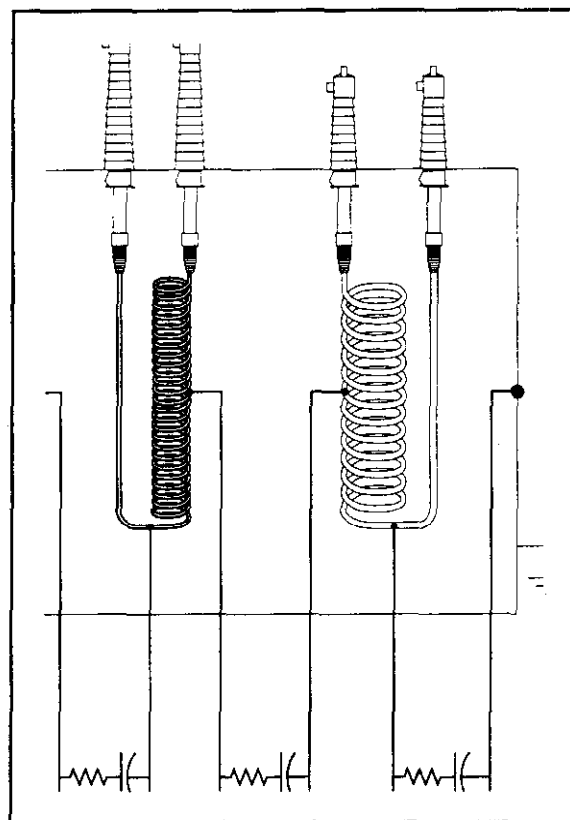

Figure 7-4. Winding losses in a transformer with contaminated dielectric.

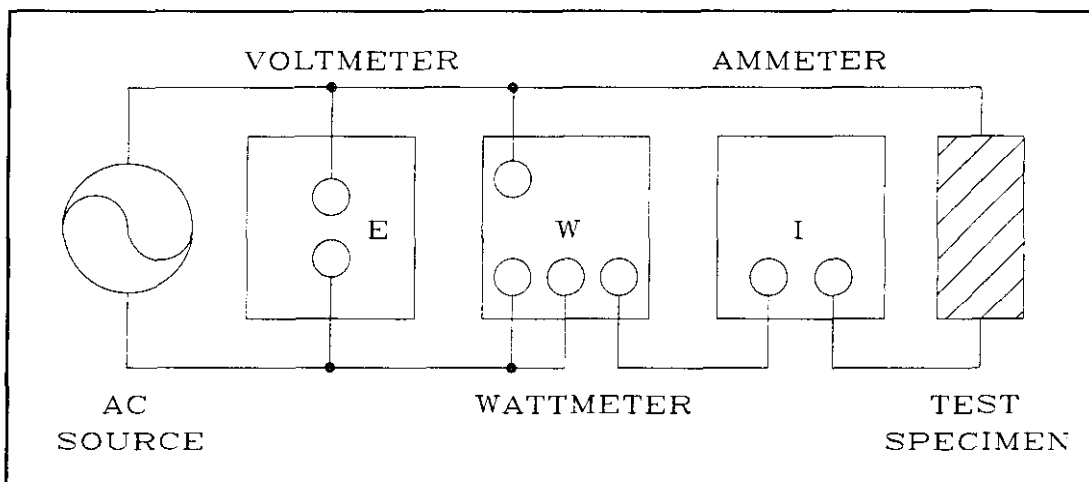

Figure 7-5. Voltmeter-ammeter-wattmeter method of measuring insulation power factor.

(3) If the insulation were purely capacitive (an ideal condition), the voltage would not reach its maximum until 90 degrees after the current had already reached its maximum. The cosine of 90 degrees is zero, representing a zero percent power factor. The ideal situation is a purely capacitive insulating quality; the existence of a minor resistive component produces a slight angular shift or displacement (a marginally acceptable power factor of 1 percent corresponds to a phase angle of 89.43 degrees, or a displacement from ideal conditions of 0.57 degrees).

(4) Any insulating medium will have a measurable power factor. Power factor tests are performed on transformers, bushings, circuit breakers, and even on insulating fluid (a special can is used to provide a controlled environment). Bushing power factor measurements are especially useful, and most larger bushings have a special voltage tap that provides a standard reference point between the conductor and ground. Bushings without this tap require a "hot collar" test (see figure 7-6), where the potential is applied to the outer surface of the bushing material and leakage currents are measured through the ceramic or epoxy of the bushings material.

(5) Another application of the power factor test is the "tip up" test, where the power factor is measured at two different potentials (usually 2.5 and 10 kV) and the results are compared. Because the power factor is a pure ratio, the results should be independent of the applied potential, and any differences will reflect the presence of moisture or other impurities that are affected differently by different applied potentials.

(6) The power factor can be measured by a metering arrangement, or by using a capacitance or resistance bridge. The quantities being measured are not only small, but they are also quite small in relation to each other. Because of these magnitudes, and because the power factor is usually determined to the tenth of a percent, it is important that the instrument(s) being used have a high degree of accuracy and reproducibility.

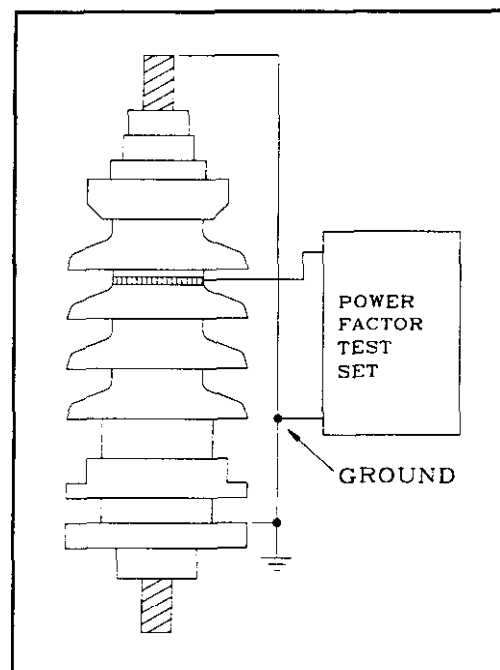

Figure 7-6. "Hot collar" bushing power factor test.

ty. This is best accomplished with a unitized test set.

(7) Although AC overpotential tests are performed on new transformers at the factory (BIL, induced voltage, and various loss measurements), they are potentially damaging, and are of little value for maintenance purposes. Also, because an AC test set must be able to achieve test potentials at alternating frequencies, relatively large sets are required to effectively charge and discharge large transformers. It is recommended that the manufacturer be contacted before performing any AC tests at above the rated voltage. In any case, the transformer should have already passed the other tests listed here, and the possibility of transformer failure should always be considered when conducting these tests.

(8) The true value of tests is realized when conducted in exactly the same manner, over a number of test intervals

CHAPTER 8

TRANSFORMER AUXILIARY EQUIPMENT

8-1. Auxiliaries

Even though the transformer is basically a static device, many changes in pressure and temperature are constantly occurring. The temperature and pressure changes must be monitored and their changes compensated. Also, because of the transformer's high voltage and power capabilities, there are areas of extremely high voltage stress, and many opportunities for large surges and fault conditions. The following auxiliary equipment is used to monitor and compensate for many of these factors, and can be found on most power transformers.

8-2. Bushings

The leads from the primary and secondary windings must be safely brought through the tank to form a terminal connection point for the line and load connections. The bushing insulator is constructed to minimize the stresses at these points, and to provide a convenient connection point. The bushing is designed to insulate a conductor from a barrier, such as a transformer lid, and to safely conduct current from one side of the barrier to the other. Not only must the bushing insulate the live lead from the tank surfaces, but it must also preserve the integrity of the tank's seal and not allow any water, air, or other outside contaminants to enter the tank.

a. There are several types of bushing construction; they are usually distinguished by their voltage ratings, although the classifications do overlap:

Solid (high alumina) ceramic—(up to 75kV)

Porcelain—oil filled (25 to 69kV)

Porcelain—compound (epoxy) filled (25 to 69kV)

Porcelain—synthetic resin bonded paper-filled (34.5 to 115kV)

Porcelain—oil-impregnated paper-filled (above 69kV, but especially above 275kV)

b. For outdoor applications, the distance over the outside surface of the bushing is increased by adding "petticoats" or "watersheds" to increase the creepage distance between the line terminal and the tank. Contaminants will collect on the surfaces of the bushing and form a conductive path. When this creepage distance is bridged by contaminants, the voltage will flashover between the tank and the conductor. This is the reason why bushings must be kept clean and free of contaminants.

c. Transformer bushings have traditionally been externally clad in porcelain because of its excellent electrical and mechanical qualities (see figure 8-1). Porcelain insulators are generally oil-filled beyond 35 kV to take advantage of the oil's high dielectric strength. There are a number of newer materials being used for bushings, including: fiberglass, epoxy, synthetic rubbers, Teflon, and silica compounds. These materials have been in use for a relatively short time, and the manufacturer's instructional literature should be consulted when working with these bushings.

d. Maintenance. Bushings require little maintenance other than an occasional cleaning and checking the connections. Bushings should be inspected for cracks and chips, and if found, should be touched-up with Glyptal paint or a similar type compound. Because bushings are often called on to support a portion of the line cable's weight, it is important to verify that any cracks have not influenced the mechanical strength of the bushing assembly.

e. Testing. Most bushings are provided with a voltage tap to allow for power factor testing of the insulator. If they have no tap, then the power factor test must be performed using the "hot collar" attachment of the test set. The insulation resistance-dielectric absorption test can also be performed between the conductor and the ground connection.

8-3. Pressure relief devices

When the transformer is overloaded for extended periods, or when an internal fault occurs, high pressures will occur in the tank. There are a number of devices used to accommodate this pressure change.

a. *Pressure relief valves.* Pressure relief valves are usually installed behind the pressure gauge on sealed tank units. They are used in conjunction with pressurized nitrogen systems and can be mounted in the gas bottle cabinet or on the tank wall. The bleeder valve is set to bleed-off any pressures that exceed a pre-set level (usually around 8-10 psi). This valve is an integral part of the pressurized gas system, and its failure can result in a rupture of the tank.

b. *Pressure relief valve testing.* The operation of these devices can be checked by manually increasing the tank pressure to the pre-set level. It is important not to exceed the maximum tank pressure. If the valve does not bleed off the excess pressure, it should be replaced.

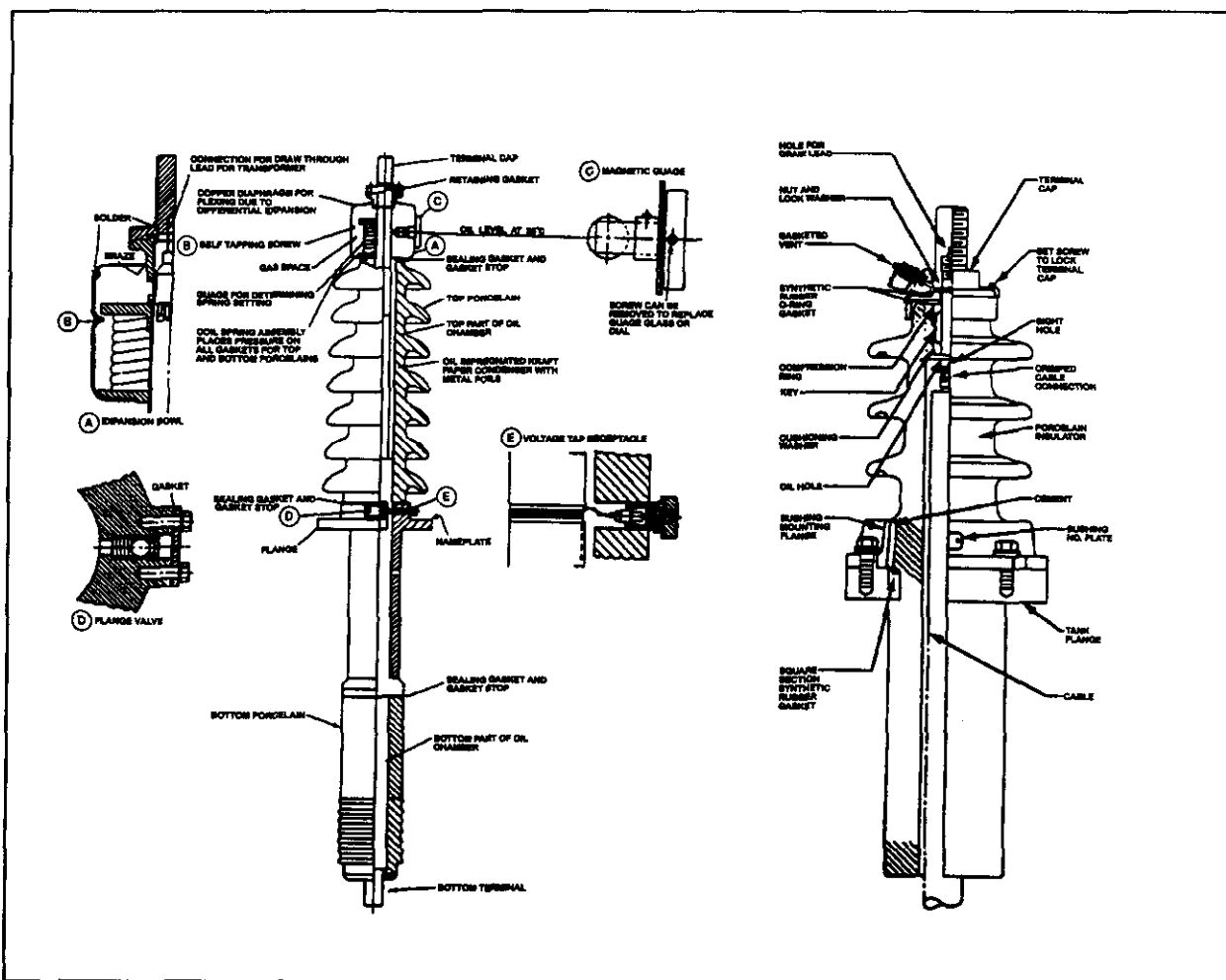

Figure 8-1. Transformer porcelain and oil filled bushings.

c. Mechanical pressure-relief devices. These devices relieve sudden or accumulated internal pressure at a predetermined value. They are usually mounted on the top of the tank, and consist of a diaphragm, a spring-loaded mechanism, and an indicating flag (see figure 8-2). When the pressure exceeds a preset level, the diaphragm is raised and the excess pressure is bled off. The indicating flag remains raised, so that the occurrence will be noted during the next inspection cycle. Some pressure relief devices are also equipped with contacts that are used to actuate external relays, alarms, or circuit breakers. The space above the tank must be purged with dry nitrogen, and the diaphragm reset any time a relief device is found with its indicating flag popped.

d. Mechanical pressure relief valve testing. A mechanical pressure relief device cannot be tested without removing it from the tank. Since removal is impractical, it should be inspected regularly to ensure there are no cracks in the diaphragm and that the diaphragm/spring mechanism is free to operate. The operation of any relay contact and the associated control wiring should also be checked periodically.

e. Relief diaphragms. Relief Diaphragms are usually found on conservator type transformers. Relief diaphragms consist of a bakelite, thin metal, or glass diaphragm mounted on a large pipe that extends above the level of the conservator tank. The diaphragm material is designed to rupture at a predetermined pressure level. Other than inspecting for evidence of rupture, there is little or no maintenance to be performed on these devices. Relief diaphragms must be replaced after rupturing.

f. Sudden pressure relays. These devices consist of a bellows, a small orifice, and a set of relay contacts that are slaved to the mechanical movement of the bellows (see figure 8-3). When the transformer undergoes the pressure changes experienced during normal operation, the small orifice bleeds off the pressure, and the bellows will not move. When an arc or an internal fault occurs, the large volume of gas generated over relatively short time frame pushes on the bellows and actuates the contacts. The contacts are used to actuate an alarm, a circuit breaker, or another relay. There are variations in the design of sudden pressure relays, but they all operate on the same basic principle. Sudden

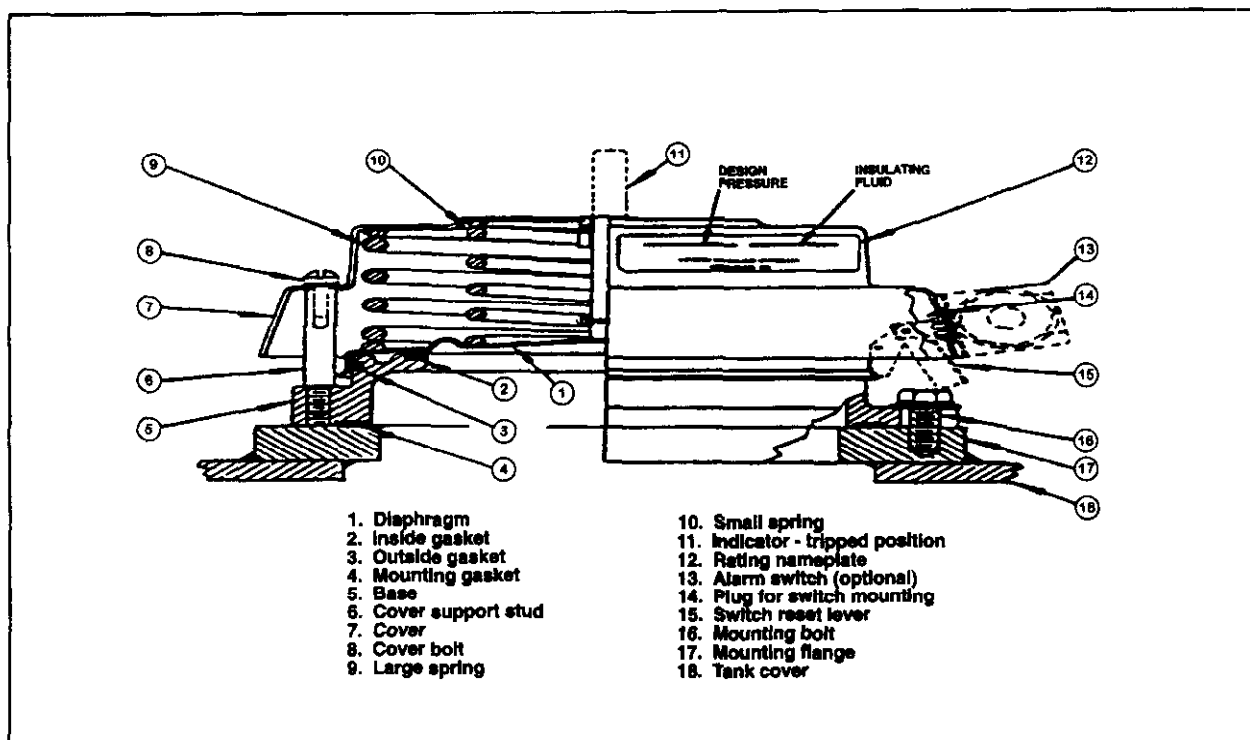

Figure 8-2. Mechanical pressure relief device.

pressure relays are not actuated by any set pressure level; they operate when the rate of change of pressure exceeds a preset value. Because arcing or internal faults generate large quantities of gas, over a short period of time sudden pressure relays are effective in detecting fault conditions. Sudden pressure relays provide little protection against over-pressure tank conditions occurring over an extended time period.

g. Sudden pressure relay testing. The sudden pressure relay is usually mounted in the gas space above the oil level, and it is important to ensure that oil does not enter the unit. The operation of the relay is verified by checking that the orifice remains open, and that the bellows is free to move. The control wiring and the contact operation should also be verified.

8-4. Pressure gauges

Most transformers are equipped with a pressure gauge. The gauge assembly consists of a pressure sensitive element (a bulb or a diaphragm), an indicator attached to the element, and a dial calibrated for the required-vacuum range of the tank. Although there is little or no maintenance to be performed on a pressure gauge, its operation should be verified if no changes are noted during a number of inspection intervals.

8-5. Temperature gauges

Temperature gauges are either of the "hot spot" or "average tank temperature" type. There are many designs in use. Most average tank temperature gauges consist of a spiral wound bi-metallic element that is directly coupled to a dial-type indicator.

a. Both average reading and hot spot temperature gauges can use a bulk-type detecting unit that is immersed in the oil either near the top of the oil level (see figure 8-4), or near the windings at the spot that is expected to be the hot test. A capillary tube is connected to the bulb and brought out of the tank. The temperature indication is provided either by a linear marking on the tube itself, or by a dial-type indicator. Dial-type gauges can have up to three sets of contacts that will actuate any of the following devices:

(1) The lowest setting usually actuates external cooling fans that will come on at a preset temperature level. The fans will shut off once the temperature has been reduced to the prescribed level.

(2) The contacts can also be set to actuate remote alarms that will alert maintenance personnel of the condition of the transformer. These devices must be reset even though the temperature has returned to normal.

(3) The highest and most critical contact setting on the temperature gauge is connected to a relay or a circuit breaker that will trip out and de-energize the transformer.

b. Most dial-type gauges (see figure 8-5) are equipped with a red indicating needle that has no spring return and will indicate the highest temperature seen since it was last reset. This slaved hand needle reading should be recorded for each inspection interval, and the needle should be reset to ambient temperature so that it will indicate the maximum temperature for the next inspection interval.

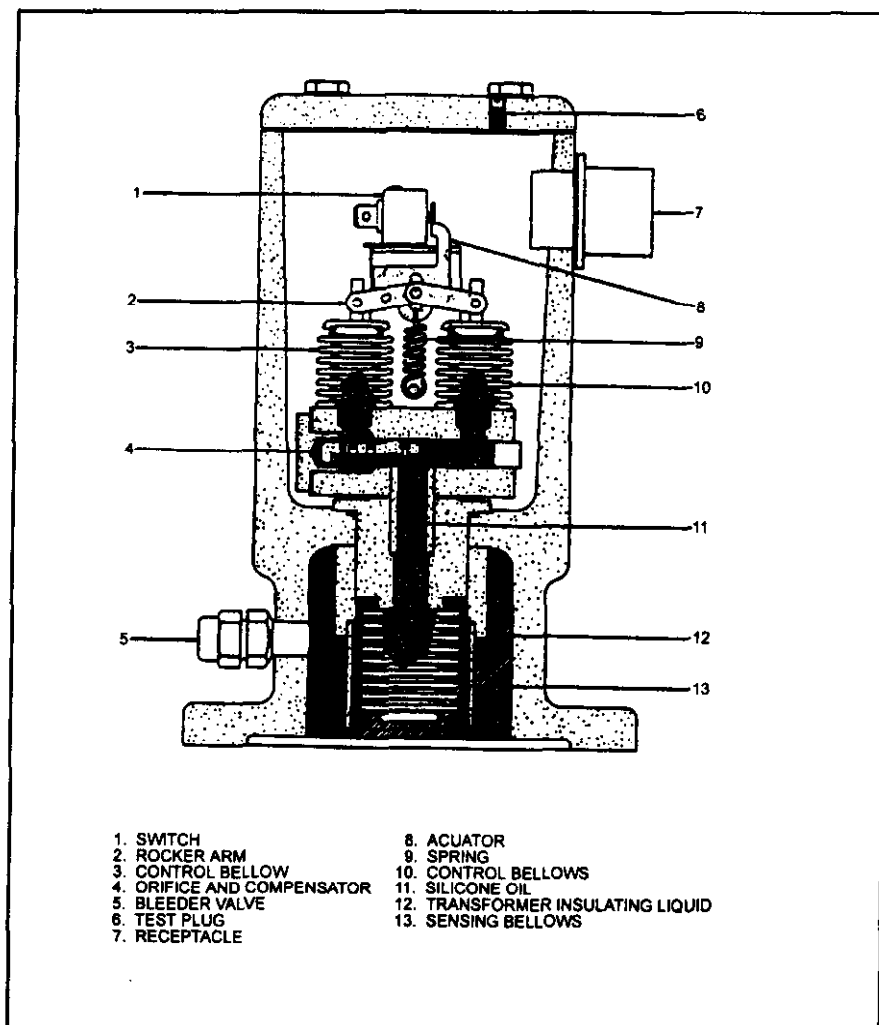

Figure 8-3. Sudden pressure relay.

8-6. Tap changers

As noted in chapter 3, transformers are often required to operate under changing primary voltages, or to provide a number of different secondary voltages. Most transformers are equipped with a tap changer (see figure 8-6), and any number of taps can be brought off of either of the windings to accomplish this voltage change. Tap changers can be conveniently divided into two categories: no-load tap changers and load tap changers.

a. No-load tap changers. No-load tap changing is usually accomplished on the primary side of a step-down power transformer. The taps are usually provided 2-1/2 percent intervals above and below the rated voltage, and the transformer must be de-energized before the tap position can be changed. The taps are changed either by turning a hand wheel, moving a selector switch, or lowering the oil level, opening the manhole, and actually reconnecting the winding leads to various positions on a terminal board. No-load tap changers are usually used to accommodate long-term variations in the primary voltage feed.

b. Load tap changers: Load tap changers are usually located on the secondary side of the transformer. They are used to control the current and voltage as the load is varied. Load tap changing transformers are used especially for furnace applications, and to regulate the changing voltages found in large substations.

(1) Because load tap changers are required to open and close the circuit while it is hot, they incorporate a number of devices to minimize the switching time and the amount of energy (the arc) released. Some tap changers use vacuum bottle type breakers to interrupt the current flow, while others use a conventional main/arcing contact mechanism, much like that found in a circuit breaker. Other tap changers use resistor or reactor circuitry in the mechanism to limit the current flow at the time the switching occurs. Load tap changers can be either automatic or manual, and can be used to vary the voltage and current by as much as 2 or 3 percent, depending on application.

(2) Most load tap changers are immersed in oil and are contained in a separate compartment from the primary and secondary windings. Because of the large

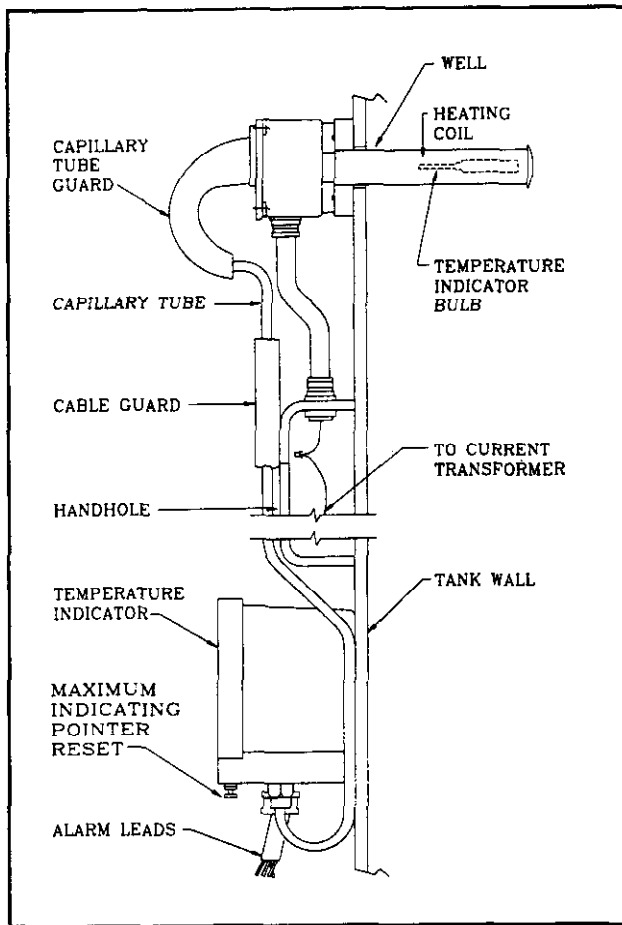

Figure 8-4. Temperature gauge.

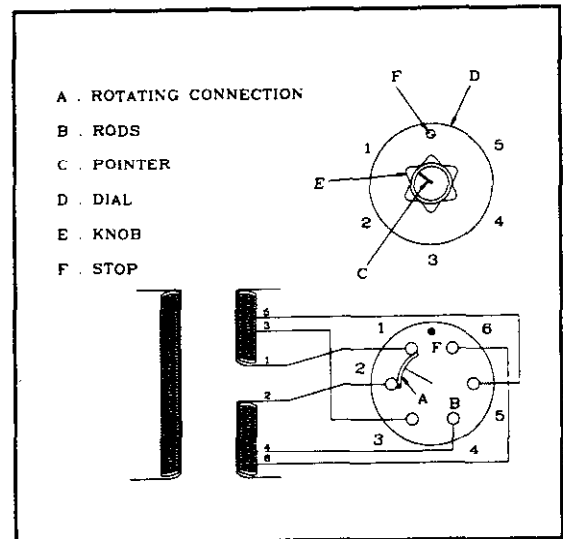

Figure 8-6. Schematic diagram of transformer tap changer.

amounts of energy (switching arcs) produced, the oil in the tap changing compartment deteriorates at a much faster rate than the oil in the main compartment.

c. *Tap changer testing.* The tap changer's operation is varied by performing a turns ratio test at the various tap settings. This holds true for both the no load tap changers. The arcing contact or vacuum bottle assemblies for the load tap changers should be inspected, and the contact resistance should be measured if there is evidence of putting or contact wear. Because of

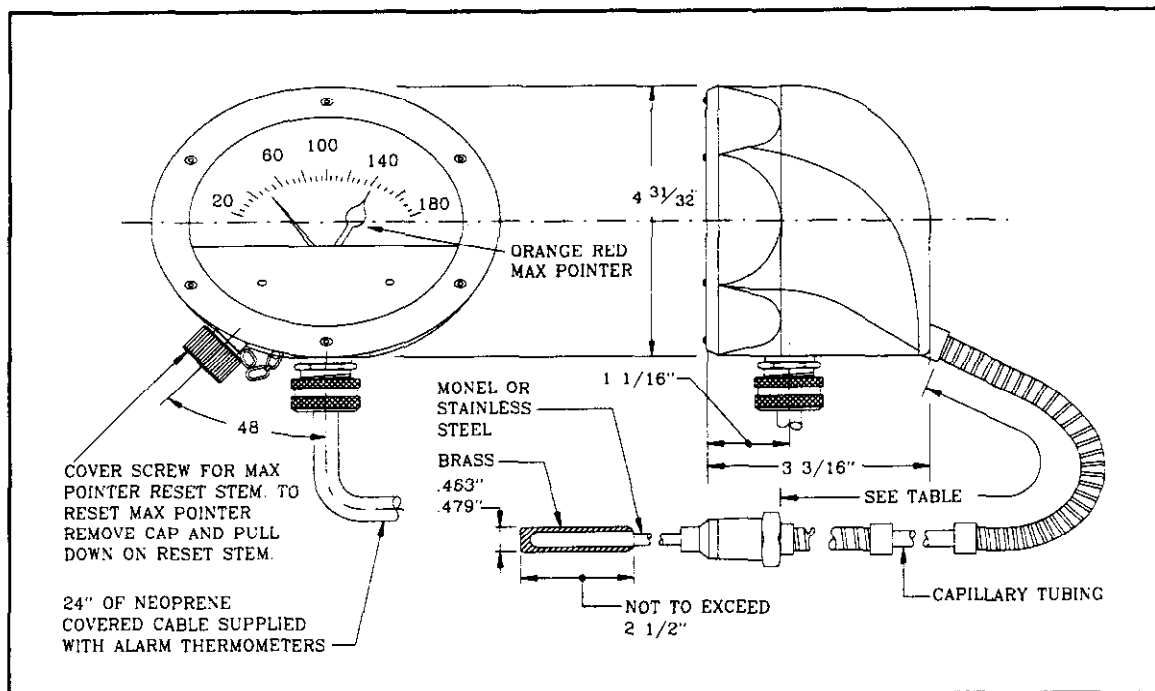

Figure 8-5. Dial type temperature gauge.

the switching activity, the oil in the tap changer compartment should be sampled and analyzed twice as often as the main tank oil.

8-7. Lightning (surge) arresters

Most transformer installations are subject to surge voltages originating from lightning disturbances, switching operations, or circuit faults. Some of these transient conditions may create abnormally high voltages from turn to turn, winding to winding, and from winding to ground. The lightning arrester is designed and positioned so as to intercept and reduce the surge voltage before it reaches the electrical system.

a. Construction. Lightning arresters are similar to high voltage bushings in both appearance and construction. They use a porcelain exterior shell to provide insulation and mechanical strength, and they use a dielectric filler material (oil, epoxy, or other materials) to increase the dielectric strength (see Figure 8-7). Lightning arresters, however, are called on to insulate normal operating voltages, and to conduct high level surges to ground. In its simplest form, a lightning arrester is nothing more than a controlled gap across which normal operating voltages cannot jump. When the voltage exceeds a predetermined level, it will be directed to ground, away from the various components (including the transformer) of the circuit. There are many variations to this construction. Some arresters use a series of capacitances to achieve a controlled resistance value, while other types use a dielectric element to act as a valve material that will throttle the surge current and divert it to ground.

b. Maintenance. Lightning arresters use petticoats to increase the creepage distances across the outer surface to ground. Lightning arresters should be kept clean to prevent surface contaminants from forming a flashover path. Lightning arresters have a metallic connection on the top and bottom. The connectors should be kept free of corrosion.

c. Testing. Lightning arresters are sometimes constructed by stacking a series of the capacitive/dielectric elements to achieve the desired voltage rating. Power factor testing is usually conducted across each of the

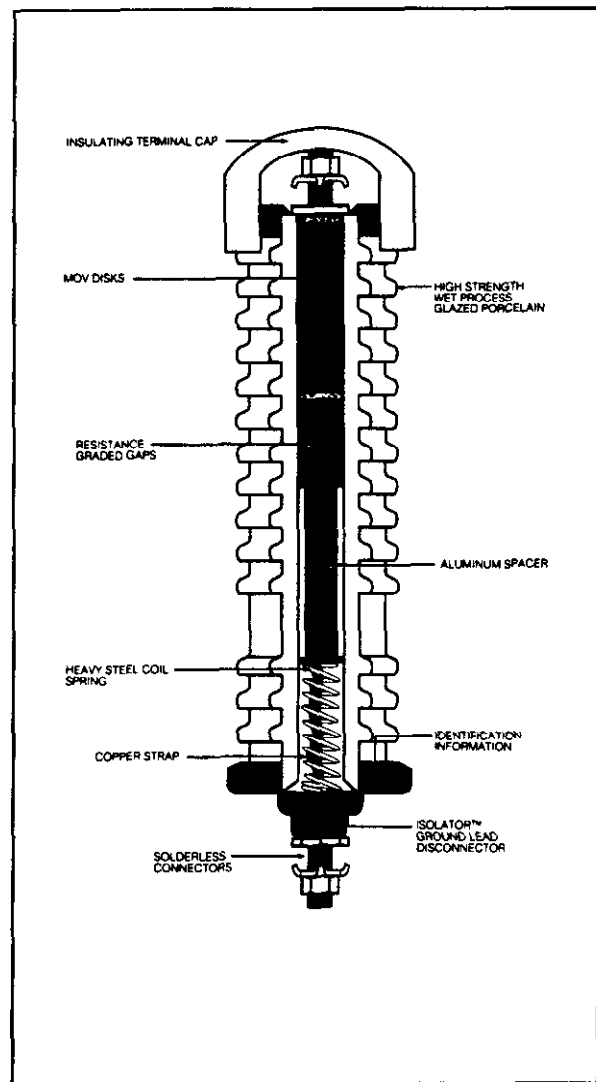

Figure 8-7. Lightning arresters.

individual elements, and, much like the power factor test on the transformer's windings, a ratio is computed between the real and apparent current values to determine the power factor. A standard insulation resistance-dielectric absorption test can also be performed on the lightning arrester between the line connection and ground.

CHAPTER 9

COMPREHENSIVE MAINTENANCE/TESTING PROGRAM

9-1. Transformer maintenance

Of all the equipment involved in a facility's electrical distribution system, the transformer is probably the most neglected. A transformer has no moving parts; consequently it is often considered maintenance-free. Because the transformer does not trip or blow when over-stressed (except under extreme conditions), it is frequently overloaded and allowed to operate well beyond its capacity. Because the transformer is usually the first piece of equipment on the owner's side of the utility feed, it usually operates at much higher voltages than elsewhere in the facility and personnel are not anxious to work on or around it. The fact that a transformer has continued to operate without the benefit of a preventive maintenance/testing program says much about the ruggedness of its construction. However, a transformer's ruggedness is no excuse not to perform the necessary testing and maintenance.

a. Any piece of electrical equipment begins to deteriorate as soon as it is installed. The determining factor in the service life of a transformer is the life of its insulation system. A program of scheduled maintenance and testing cannot only extend the life of the transformer, but can also provide indications of when a transformer is near the end of its service life, thus allowing for provisions to be made before an unplanned failure occurs. Also, a transformer checked before a failure actually occurs can usually be reconditioned or refurbished more easily than if it had failed while on line.

b. There are many benefits to a comprehensive maintenance and testing program:

(1) Safety is increased because deficiencies are noted and corrected before they present a hazard.

(2) Equipment efficiency is increased because conditions that ultimately increase the transformer's losses can be corrected.

(3) If a problem occurs, it can usually be rectified more quickly because service records and equipment information are centrally located and readily available.

(4) As the power requirements of a facility grow, any overloaded or unbalanced circuits will be detected more quickly, allowing for adjustments to be made before any damage is incurred.

(5) If impending failures are discovered, the repair work can be scheduled during off-peak hours, reducing the amount of inconvenience and expense.

c. To realize these benefits, a comprehensive plan must be thoughtfully developed and diligently administered. Although the generalized needs of transformers are addressed here, depending on construction and application, transformers may need more or less frequent attention than specified here. Once again, there are simply guidelines, and in no instance should the manufacturer's recommendations be neglected.

9-2. Maintenance and testing program

A comprehensive maintenance and testing program is instituted for a number of reasons and benefits. The objective of a comprehensive program is not just to get the work done, but to ensure that the work is completed according to a methodical and priority-oriented plan of action. A comprehensive program ensures that all maintenance needs are fulfilled, and that testing and inspections are performed to verify that the equipment is not deteriorating at an accelerated rate. By documenting all activities and performing the work as part of an overall plan, the program also helps to eliminate any redundancies or duplication efforts. There are five basic activities involved in a comprehensive program:

a. Inspections. Inspections do not require an outage, and can therefore be performed more frequently than most other maintenance functions. Inspections are a very effective and convenient maintenance tool. If inspections are carefully performed along with an oil analysis they can reveal many potential problems before damage occurs. A transformer inspection should include all gauge and counter readings, the operating conditions of the transformer at the time of the inspection, a check of all auxiliary equipment, the physical condition of the tank, and any other visible factors that affect the operation of the transformer. Inspections should be conducted on a weekly basis, and should be thoroughly documented and stored with the transformer's service records.

b. Infrared (IR) Imaging. Infrared imaging is also an effective inspection tool. Loose connections, unbalanced loads, and faulty wiring will all emit relatively higher levels of heat than their surroundings. Infrared imaging systems provide a screen display (like a TV) that shows the temperature difference of the items on the screen. It is the relative difference in temperature, and not the actual temperature that will indicate any

problems. If the IR scan is performed annually, it should be performed 6 months after the annual maintenance outage, to maximize protection between the hands-on service intervals.

c. Sampling. Drawing samples of the transformer's fluid provides the opportunity to actually remove a portion of the transformer's insulation and subject it to a battery of standardized tests, under controlled laboratory conditions, with the benefit of complex laboratory equipment. Most transformers can be sampled while energized, so there is no major inconvenience involved. Although samples should be taken more frequently at the outset of a program (every 6 months), once the baseline data and the rate of deterioration have been determined, the frequency can usually be adjusted according to the needs of the transformer (normally once a year).

d. Maintenance. Most maintenance functions require an outage since they present a hazard to the personnel involved. Maintenance functions involve periodic actions that are performed as a result of the expected wear and tear and deterioration of the transformer. They include wiping down all bushings and external surfaces, topping off fluids, tightening connections, reconditioning deteriorated oil, recharging gas blankets and checking gas bottles, touching-up the paint, fixing minor leaks, and doing any maintenance required for fan systems and tap changer systems. Most of these operations should be performed annually, when the transformer is de-energized for testing.

e. Testing. Testing provides functional verification of the condition of the transformer. All transformer testing requires an outage. The tests that should be performed on a regularly scheduled basis are: Power factor, Insulation resistance-Dielectric absorption, Turns ratio and Winding resistance. Testing is an important part of a comprehensive program because it uses electricity to verify the operating condition of the transformer. Most outdoor transformers should be tested annually, although lightly loaded transformers in favorable environments can get by with testing every 3 years. More frequent testing should be performed at the outset of a program to determine the specific transformer's needs.

f. Repair. Although there is little distinction between maintenance and repair activities, the planned or unplanned nature of the work will usually determine its category. The whole idea of the comprehensive program is to minimize the amount of unplanned downtime necessary for repairs. When the deterioration of the transformer's oil is monitored, and arrangements are made to recondition the oil during a planned outage, it can be called a maintenance function. When a transformer fault occurs, and subsequent testing reveals that the oil is unfit for service, the unplanned oil reconditioning becomes a repair function; in this case, there is a much more significant inconvenience factor.

9-3. Documentation

Performing the work on the transformer is all well and good, but the information gained is practically useless if it cannot be easily accessed and compared to other test results. To ensure that all inspection, test, analysis, maintenance, and repair data can be used most effectively, the data must be properly documented and readily accessible. This usually involves keeping records of all activities in a centralized filing system.

a. Although the technician performing the work is ultimately responsible for getting the information on paper, a properly constructed record will not only help the technician, but will also help the personnel responsible for organizing and storing the data. Every record, whether it is an inspection, test, or repair record should have as much information about the transformer and the test conditions as possible. This includes the manufacturer, the kVA rating, the serial number, and the voltage ratings. There should also be space on the record to note the temperature, humidity, and weather conditions at the time of the activity. Another factor that can be extremely important is the loading conditions immediately prior to (for de-energized activities) or during (for inspections or sampling) the service procedure. All of this information can be extremely helpful for interpreting the results.

b. Several factors should be taken into consideration when devising a maintenance program for a specific transformer. The two most important factors are the environment in which the transformer is operating and the load to which it is being subjected. Although the exact effect these conditions will have on the transformer may not be known at the outset, the rate of deterioration should be determined by the end of the first year of the program and any adjustment can be made after that.

9-4. Scheduling

It is very easy to prescribe maintenance and testing, and most facilities management personnel will agree to the benefits of the program. It is when the outage must be obtained to perform the work that the problems arise. This is where the comprehensive part of the program comes into play. It is the responsibility of the maintenance department to work with all the departments involved to schedule the necessary outages.

a. Once all involved parties have decided to institute a preventive maintenance and testing program, the maintenance needs of the transformer and the availability of the outages necessary to perform the work must be considered. Because the power transformer usually affects a large portion of the electrical service to a facility, scheduling outages can be extremely difficult. Quite often, the work must be performed at night or during off-peak hours over the weekend. Although this can sometimes cause major inconveniences, the

work must be performed, and the biggest help the maintenance personnel/department can provide is to minimize the time required for the outage.

b. Except for visual inspections, infrared (IR) inspections and sampling, all transformer maintenance/testing procedures require an outage. Unless there are redundant systems such as generators and alternate feeds, the outage will black out portions of the facility. It is important that all equipment be assembled and preparations be made before the switch is thrown. This includes having all the necessary test equipment and spare parts on hand. Although it may be difficult to estimate the amount of time each service procedure will require, as the program is implemented, these factors will be easier to estimate, and they will be performed more quickly as the maintenance personnel become more experienced.

c. The transformer should be inspected on a weekly basis. This inspection should be thoroughly documented, and should include all gauge readings, load currents, and the visual condition of all the transformer's auxiliary equipment. If unexplained maximum temperatures occur or if there is an accelerated deterioration, daily inspections, or the use of load recording instruments should be considered. Infrared scanning can also be performed without an outage. The IR scan should be performed every 6 or 12 months, depending on the transformer type and application.

d. The transformer's insulating fluid should be sampled every 6 months during the first year of the pro-

gram and annually for the remainder of its service life. If problems are noted, or if the oil begins to deteriorate at an accelerated pace, the transformer should be sampled more frequently. Tap changers and auxiliary switching compartments should also be sampled more frequently. The information for each sampling interval should be transcribed onto a record that will allow easy trending analysis. If an outside contractor is called into to perform the sampling and analysis, the record should include the sample information shown, especially the atmospheric conditions at the time of the test.

e. The comprehensive maintenance and testing program will be most effective if the various electrical tests are coordinated by a central department. The testing and maintenance of equipment other than transformers in the facility's electrical distribution system should be integrated into an overall program. By centralizing the maintenance activities for all of the facility's electrical equipment, other items in each individual circuit can be investigated to help explain any problems being experienced on a specific piece of equipment. Centralizing the various inspection/test/repair records also promotes the development of trending data, and the analysis of test data over a number of test intervals. This centralized filing system should also be used to generate schedules and to plan activities. If possible, a computerized system should be used to generate schedules and to plan activities. If possible, a computerized system should be established to indicate when the items in the system are due for service.

CHAPTER 10

STATUS OF TRANSFORMER MONITORING AND DIAGNOSTICS

10-1. Introduction

As a key component of all AC power systems, a properly functioning power transformer is essential for maintenance system integrity. Consequently, new and improved monitoring and diagnostic techniques continue to be developed to minimize unplanned system outages and costly repairs.

10-2. Transformer monitoring

For the purposes of this section, monitoring refers to on-line measurement techniques, where the emphasis is on collecting pertinent data on transformer integrity and not on interpretation of data. Transformer monitoring techniques vary with respect to the sensors used, transformer parameters measured, and measurement techniques applied. Since monitoring equipment is usually permanently mounted on a transformer, it must also be reliable and inexpensive.

a. To minimize costs, it is important to minimize the number of measurements taken. It is therefore necessary to identify parameters that are most indicative of transformer condition. Consequently, selection of these parameters must be based on failure statistics, as

shown in figure 10-1. The pie chart shows typical failure distribution of transformers with on-load tap changers (OLTC). As indicated, winding and OLTC failures dominate; consequently, the focus of most monitoring techniques is to collect data from parameters that can be used to assess the condition of winding and tap changers. Dissolved gases in oil and partial discharges (PD) are common parameters monitored related to winding and insulation condition. Temperature and vibration monitoring are commonly used for assessing OLTC condition.

b. Dissolved Gases in oil: As mentioned in paragraph 5-3 of this manual, dissolved gas-in-oil analysis is an effective diagnostic tool for determining problems in transformer operation. However, this analysis is typically performed off-post, where sophisticated (and usually expensive), equipment is used to determine gas content. To reduce the risk of missing incipient faults due to long sampling intervals, monitoring techniques are being developed to provide warnings with respect to changes in gas types and concentrations observed within a transformer. Conventional dissolved gas-in-oil analysis is performed after a warning is issued. Several

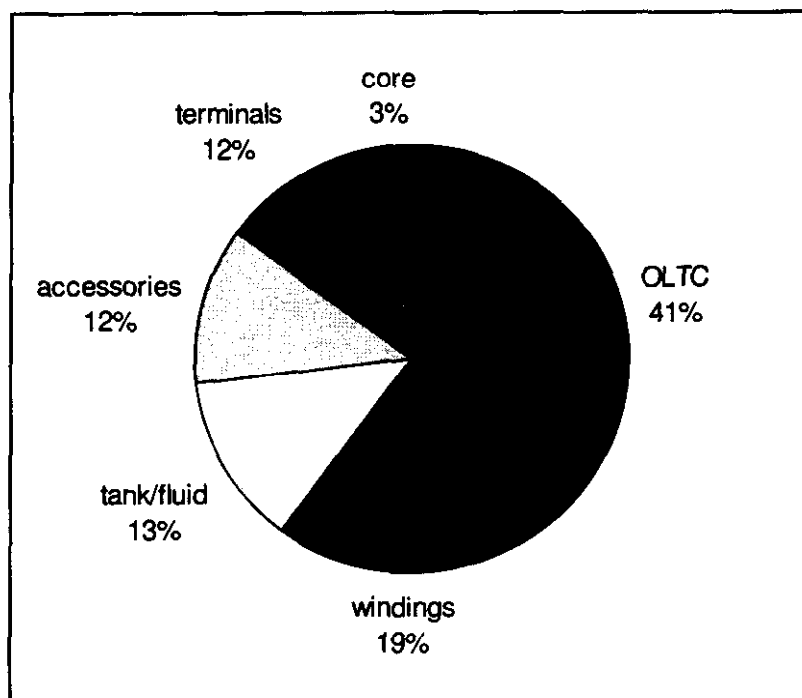

Figure 10-1. Typical failure distribution for substation transformers.

transformer gases and corresponding sources are listed in Table 10-1.

c. The main challenges to on-line gas monitoring are not only to develop accurate and low cost sensors, but sensors that are versatile enough to detect the presence of multiple gases. Several new sensor technologies are now commercially available to measure concentration changes of multiple gases, and many more are in development. The HYDRAN technology for example, by Syprotec Inc. (Montreal, Quebec), uses a selectively permeable membrane and a miniature electrochemical gas detector to measure the presence of hydrogen, carbon monoxide, ethylene and acetylene dissolved in oil. The chemical reactions, which result when these gases permeate through the membrane and mix with oxygen, generate electrical current that is measured as a voltage drop across a load resistor. This voltage drop is used to determine a composite parts-per-million value of the four gases. This technology is used to detect change in gas concentrations only. If change is detected, an alarm is triggered, which indicates that an oil sample should be taken from the transformer and analyzed to evaluate the nature and severity of the fault. The Transformer Gas Analyzer, developed by Micromonitors, is also designed to detect hydrogen, carbon monoxide, ethylene, and acetylene in mineral oil-filled transformers. The instrument operates on a real-time basis with sensors immersed directly in the oil inside the transformer, and is based on metal insulator semiconductor technology. The AMS-500 PLUS, by Morgan Shaffer Company, measures both dissolved hydrogen and water continuously, on-line. Asea Brown Boveri is developing sensors based on metal oxide technology; however, these sensors are still in the field prototype stage.

(1) *Partial Discharges*: The most common method for on-line detection of partial discharges (PD) is the use of acoustical sensors mounted external to the transformer. One example of a commercially available acoustic emission monitoring instrument is the Corona 500, by NDT International, Inc., which is designed to detect partial discharge of electrical transformers while on-line. The main difficulty with using acoustical sensors in the field, however, is in distinguishing

between internal transformer PD and external PD sources, such as discharges from surrounding power equipment. An alternative method has been proposed recently to differentiate between internal and external PD, and is based on the combined use of signals from a capacitive tap and signals from an inductive coil fitted around the base of the bushing. A warning signal is provided if PD activity develops inside the tank; therefore, this technique does not indicate the seriousness of the internal defect.

(2) *Temperature*. The load capability of a transformer is determined by the maximum allowable hot spot temperature of the winding. Hot spot values are usually calculated from measurements of oil temperatures and load current. A more expensive technique is to use distributive fiber optic temperature sensors. Since tap changer condition is a key transformer component, another method consists of metering and monitoring the differential temperature between the main tank and tap changer compartment. This method can be used for detecting coking of contacts. For example, the Barrington TDM-2L, by Barrington Consultants (Santa Rosa, CA), measures oil temperature in the tap changer compartment and in the main tank. This technology is designed to interface with a SCADA system and also provides local digital indication for main tank, OLTC, differential, peak and valley oil temperatures.

(3) *Vibration*: Vibration monitoring has also been proposed for detecting mechanical and electrical faults in the OLTC compartments. The method is still under development, but could prove to be an effective technique for detecting OLTC mechanical problems such as failing bearings, springs, and drive mechanisms, as well as deteriorating electrical contracts.

(4) *Other Methods*: Recently, there has been a considerable amount of research effort focused on improving the intelligence of transformer monitoring systems. The approach is to compare the results of actual measurements for example, using the sensors mentioned above) with predictions obtained through simulation models. Model parameters are determined to best fit past transformer measurements. For normal transformer operation, simulation results should match the results obtained from actual measurements. However,

Table 10-1. Transformer gases and corresponding sources.

Hydrogen	Corona, partial discharge,
Oxygen, nitrogen	Water, rust, poor seals
Carbon monoxide, carbon	Cellulose breakdown
Methane, ethane	Low temperature oil
Ethylene	High temperature oil
Acetylene	Arcing

measurements deviating from predictions may indicate a problem with the transformer. The claim is that this technique can provide very sensitive measures of transformer performance. For example, the Massachusetts Institute of Technology uses adaptive mathematical models of transformer subcomponents that tune themselves to each transformer using parameter estimation. They have used the model-based approach for accurate on-line prediction of top oil temperature, which has been verified using data from a large transformer in service. Of course, other performance predictions can be made using appropriate measurable quantities such as dissolved gas content.

10-3. Transformer diagnostics

For the purposes of this section, diagnostics refers to the interpretation of data and measurements that are performed off-line. Diagnostics are used as a response to warning signals and to determine the actual condition of a transformer. Since it is not a permanent part of a transformer, diagnostic equipment is typically much more sophisticated and expensive than monitoring equipment.

a. Dissolved gas-in-oil analysis is the most common method for incipient fault detection. This section will focus on discussing the results of two research efforts including: (1) an expert system approach based on dissolved gas analysis; and (2) an artificial neural network approach to detect incipient faults.

b. Expert System Approach. The analysis of the mixture of faulty gases dissolved in transformer mineral oil has been recognized for many years as an effective method for the detection of incipient faults. Experts from industry, academia, and electric utilities have reported worldwide on their experiences, and have developed criteria on the basis of dissolved gas analysis (DGA). The objective of one expert system approach is to develop a rule-based expert system to perform transformer diagnosis similar to a human expert. Results from a prototype expert system based on DGA has been published. The main difficulty to be overcome is transforming qualitative human judgments into quantitative expressions. The prototype expert system uses fuzzy-set models to facilitate this transformation. In short, the fuzzy-set model is used for representing decision rules using vague quantities. For

example, the prototype system uses a fuzzy set to manage three diagnostic uncertainties, including: norms, gas ratio boundaries, and key gas analysis. Results from the prototype study indicate that an expert system could be a useful tool to assist maintenance personnel.

c. Artificial Neural Network Approach: With a similar focus as the expert system and fuzzy-set approach, researchers are also using artificial neural networks (ANN) to reveal some of the hidden relationships in transformer fault diagnosis. Very complex systems can be characterized with minimal explicit knowledge using ANNs. The relationship between gas composition and incipient-fault condition is learned by the ANN from actual experience. The aim of using ANN is to achieve better diagnosis performance by detecting relationships that are not apparent (that is, relationships that might otherwise go unnoticed by the human eye). For example, cellulose breakdown is a source of carbon monoxide; however, overheating, corona and arcing all cause this type of breakdown. The primary difficulty is in identifying and acquiring the data necessary for properly training an ANN to recognize certain complex relationships. The more complex a relationship is, the more training data are needed. The study presented in the Zhang, Ding, Liu, Griffin reference used five gases as input features including, hydrogen, methane, ethane, ethylene, and acetylene. The results of the study look promising, and indicate that the reliability of the ANN approach might be improved by incorporating DGA trend data into ANN training, such as increasing rates of gas generation.

10-4. Conclusions

Several new on-line monitoring technologies are now commercially available, and more are in development. Research is being conducted that is focused on providing on-line diagnostic capability using model-based techniques. A trend toward developing more accurate and effective incipient fault diagnostics, based on past experience with dissolved gas-in-oil analyses, is evident from the recent development of expert systems and artificial neural networks. As sensor technology and interpretation skills mature, it is likely that a shift will be made toward performing on-line diagnostics.

APPENDIX A

REFERENCES

Related Publications

American National Standards Institute (ANSI):
11 West 42nd Street, New York, NY 1036

ANSI C57.
Lead markings of large transformers

American Society for Testing and Materials (ASTM):
1916 Race Street, Philadelphia, PA 19103-1187

ASTM D-887
Test for dielectric strength of oil

ASTM D-924
Test of oil power factor

ASTM D-971
Test of oil film strength

ASTM D-974
Test for contaminants in oil

ASTM D-1500
Test of oil color

ASTM D-1533
Test of moisture content in oil

ASTM D-1816
Test for dielectric strength of oil above 230 KV

ASTM B-2285
Test of oil film strength using a different method than ASTM D-971

GLOSSARY

Section I Abbreviations

A, AMP
amperes

AC
alternating current

ANSI
American National Standards Institute

ASTM
American Society for Testing Material

BIL
basic impulse level

C
Centigrade

CFM
cubic feet per minute

DC
direct current

F
Fahrenheit

Hz
hertz

IEEE
Institute of Electrical and Electronics Engineers

IR
infrared

kV
kilo volts

kVA
kilo volt amperes

kVAR, kilovars
kilo volt amperes reactance

kW
kilo watts

Milliampere
1 millionth of an ampere

Megohm
1 million ohms

Milliohm
1 millionth of an ohm

TM 5-686

NEC

National Electrical Code

NEMA

National Electrical Manufacturers Association

NFPA

National Fire Protection Association

PCB

polychlorinated biphenyls

PF

power factor

pH

pouvoir hydrogene

PPM

parts per million

PSI

pounds per square inch

PT

potential transformer

V

volt

VAR

volt amperes reactance

W

watt

A, AMP

amperes

Section II Terms

AA

An Ansi (American National Standard Institute) cooling class designation indicating open, natural-draft ventilated transformer construction, usually for dry-type transformers.

Ambient Temperature

The temperature of the surrounding atmosphere into which the heat of the transformer is dissipated.

Ampere

Unit of current flow.

ANSI (American National Standards Institute)

An organization that provides written standards on transformer [600v and below (ANSI C89.1), 601v and above (ANSI C57.12)].

Autotransformer

A transformer in which part of the winding is common to both the primary and the secondary circuits.

BIL

Basic Impulse Level, the crest (peak) value that the insulation is required to withstand without failure.

Bushing

An electrical insulator (porcelain, epoxy, etc.) that is used to control the high voltage stresses that occur when an energized cable must pass through a grounded barrier.

Cast-coil Transformer

A transformer with high-voltage coils cast in an epoxy resin. Usually used with 5 to 15 kV transformers.

Continuous Rating

Defines the constant load that a transformer can carry at rated primary voltage and frequency without exceeding the specified temperature rise.

Copper Losses

See Load Losses.

Core-Form Construction

A type of core construction where the winding materials completely enclose the core.

Current Transformer

A transformer generally used in instrumentation circuits that measure or control current.

Delta

A standard three-phase connection with the ends of each phase winding connected in series to form a closed loop with each phase 120 degrees from the other. Sometimes referred to as 3-wire.

Delta Wye

A term or symbol indicating the primary connected in delta and the secondary in wye when pertaining to a three-phase transformer or transformer bank.

Distribution Transformers

Those rated 5 to 120 kV on the high-voltage side and normally used in secondary distribution systems. An applicable standard is ANSI C-57.12.

Dripproof

Constructed or protected so that successful operation is not interfered with by falling moisture or dirt.

Dry-Type

A transformer in which the transformer core and coils are not immersed in liquid.

Exciting Current (No-load Current)

Current that flows in any winding used to excite the transformer when all other windings are open-circuited. It is usually expressed in percent of the rated current of a winding in which it is measured.

FA

An ANSI cooling class designation indicating a forced air ventilated transformer, usually for dry type transformers and typically to increase the transformers and typically to increase the transformer's KVA rating above the natural ventilation or AA rating.

Fan Cooled

Cooled mechanically to stay within rated temperature rise by addition of fans internally and/or externally. Normally used on large transformers only.

FOA

An ANSI cooling class designation indicating forced oil cooling using pumps to circulate the oil for increased cooling capacity.

FOW

An ANSI cooling class designation indicating forced oil water cooling using a separate water loop in the oil to take the heat to a remote heat exchanger. Typically used where air cooling is difficult such as underground.

Frequency

On AC circuits, designate number of times that polarity alternates from positive to negative and back again, such as 60 hertz (cycles per second).

Grounds or Grounding

Connecting one side of a circuit to the earth through low-resistance or low-impedance paths. This help prevent transmitting electrical shock to personnel.

High-voltage and Low-voltage Windings

Terms used to distinguish the wind that has the greater voltage rating from that having the lesser in two-winding

TM 5-686

transformers. The terminations on the high-voltage windings are identified by H1, H2, etc., and on the low-voltage by X1, X2, , etc.

Impedance

Retarding forces of current flow in AC circuits.

Indoor Transformer

A transformer that, because of its construction, is not suitable for outdoor service.

Insulating Materials

Those materials used to electrically insulate the transformer windings from each other and to ground. Usually classified by degree of strength or voltage rating (O, A, B, C, and H).

kVA or Volt-ampere Output Rating

The kVA or volt-ampere output rating designates the output that a transformer can deliver for a specified time at rated secondary voltage and rated frequency without exceeding the specified temperature rise (1 kVA = 1000 VA).

Liquid-immersed Transformer

A transformer with the core and coils immersed in liquid (as opposed to a dry-type transformer).

Load

The amount of electricity, in kVA or volt-amperes, supplied by the transformer. Loads are expressed as a function of the current flowing in the transformer, and not according to the watts consumed by the equipment the transformer feeds.

Load Losses

Those losses in a transformer that are incident to load carrying. Load losses include the I^2R loss in the winding, core clamps, etc., and the circulating currents (if any) in parallel windings.

Mid-tap

A reduced-capacity tap mid-day in a winding—usually the secondary.

Moisture-resistant

Constructed or treated so as to reduce harm by exposure to a moist atmosphere.

Natural-draft or Natural-draft Ventilated

An open transformer cooled by the draft created by the chimney effect of the heated air in its enclosure.

No-load Losses (Excitation Losses)

Loss in a transformer that is excited at its rated voltage and frequency, but which is not supplying load. No-load losses include core loss, dielectric loss, and copper loss in the winding due to exciting current.

OA

An ANSI cooling class designation indicating an oil filled transformer.

Parallel Operation

Single and three-phase transformers having appropriate terminals may be operated in parallel by connecting similarly-marked terminals, provided their ratios, voltages, resistances, reactances, and ground connections are designed to permit paralleled operation and provided their angular displacements are the same in the case of three-phase transformers.

Polarity Test

A standard test performed on transformers to determine instantaneous direction of the voltages in the primary compared to the secondary (see Transformer Tests).

Poly-phase

More than one phase.

Potential (Voltage) Transformer

A transformer used in instrumentation circuits that measure or control voltage.

Power Factor

The ratio of watts to volt-amps in a circuit.

Primary Taps

Taps added in the primary winding (see Tap).

Primary Voltage Rating

Designates the input circuit voltage for which the primary winding is designed.

Primary Winding

The primary winding on the energy input (supply) side.

Rating

The output or input and any other characteristic, such as primary and secondary voltage, current, frequency, power factor and temperature rise assigned to the transformer by the manufacturer.

Ratio Test

A standard test of transformers used to determine the ratio of the primary to the secondary voltage.

Reactance

The effect of inductive and capacitive components of the circuit producing other than unity power factor.

Reactor

A device for introducing inductive reactance into a circuit for motor starting, operating transformers in parallel, and controlling current.

Scott Connection

Connection for polyphase transformers. Usually used to change from two-phase to three-phase to three-phase to two-phase.

Sealed Transformer

A transformer completely sealed from outside atmosphere and usually contains an inert gas that is slightly pressurized.

Secondary Taps

Taps located in the secondary winding (see Tap).

Secondary Voltage Rating

Designates the load-circuit voltage for which the secondary winding (winding on the output side) is designed.

Series/Multiple

A winding of two similar coils that can be connected for series operation or multiple (parallel) operation.

Shell-type Construction

A type of transformer construction where the core completely surrounds the coil.

Star Connection

Same as wye connections.

Step-down Transformer

A transformer in which the energy transfer is from the high-voltage winding to the low-voltage winding or windings.

Step-up Transformer

A transformer in which the energy transfer is from the low-voltage winding to a high-voltage winding or windings.

T-Connection

Use of Scott Connection for three-phase operation.

Tap

A connection brought out of a winding at some point between its extremities, usually to permit changing the voltage or current ratio.

Temperature Rise

The increase over ambient temperature of the winding due to energizing and loading the transformer.

Total Losses

The losses represented by the sum of the no-load and the load losses.

Transformer

An electrical device, without continuously moving parts, which, by electro-magnetic induction, transforms energy from one or more circuits to other circuits at the same frequency, usually with changed values of voltage and current.

TM 5-686

Turns Ratio (of a transformer)

The ratio of turns in the primary winding to the number of turns in the secondary winding.

Volt-amperes

Circuit volts multiplied by circuit amperes.

Voltage Ratio (of a transformer)

The ratio of the RMS primary terminal voltage to the RMS secondary terminal voltage under specified conditions of load.

Voltage Regulation (of a transformer)

The change in secondary voltage that occurs when the load is reduced from rated value to zero, with the values of all other quantities remaining unchanged. The regulation may be expressed in percent (or per unit) on the basis of the rated secondary voltage at full load.

Winding Losses

See Load Losses.

Winding Voltage Rating

Designates the voltage for which the winding is designed.

Wye Connection (Y)

A standard three-phase connection with similar ends of the single-phase coils connected to a common point. This common point forms the electrical neutral point and may be grounded.

The proponent agency of this publication is the Chief of Engineers, United States Army. Users are invited to send comments and suggested improvements on DA Form 2028 (Recommended Changes to Publications and Blank Forms) directly to HQUSACE, (ATTN: CECPW-EE), Washington, DC 20314-1000.

By Order of the Secretary of the Army:

DENNIS J. REIMER
General, United States Army
Chief of Staff

Official:

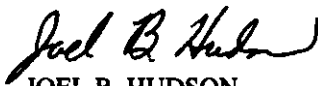
JOEL B. HUDSON
Administrative Assistant to the
Secretary of the Army

Distribution:

To be distributed in accordance with Initial Distribution Number (IDN), 344686, requirements for TM 5-686.