

**MAINTENANCE AND REPAIR  
OF SURFACE AREAS**

**APPROVED FOR PUBLIC RELEASE; DISTRIBUTION IS UNLIMITED**

---

**DEPARTMENTS OF THE ARMY, THE NAVY, AND THE AIR FORCE  
27 OCTOBER 1995**

## **REPRODUCTION AUTHORIZATION/RESTRICTIONS**

**This manual has been prepared by or for the Government and, except to the extent indicated below, is public property and not subject to copyright.**

**Copyrighted material included in the manual has been used with the knowledge and permission of the proprietors and is acknowledged as such at point of use. Anyone wishing to make further use of any copyrighted material, by itself and apart from this text, should seek necessary permission directly from the proprietors.**

**Reprints or republications of this manual should include a credit substantially as follows: "Joint Departments of the Army, Navy and Air Force, TM 5-624/NAVFAC DM MO-102/AFJMAN 321040, Maintenance and Repair of Surface Areas, 27 October 1995."**

**If the reprint or republication included copyrighted material, the credit should also state: "Anyone wishing to make further use of copyrighted material, by itself and apart from this text, should seek necessary permission directly from the proprietors."**

TECHNICAL MANUAL  
No. 5-624  
NAVY MANUAL  
NAVFAC DM MO-102  
A/R FORCE MANUAL  
No. 32-1040



HEADQUARTERS  
DEPARTMENTS OF THE ARMY  
THE NAVY, AND THE AIR FORCE  
WASHINGTON, DC, 27 October 1995

**MAINTENANCE AND REPAIR OF SURFACE AREAS**

CHAPTER		Paragraph	Page
1.	GENERAL		
	Purpose .....	1-1	1-1
	Scope .....	1-2	1-1
	References .....	1-3	1-1
	General Principles for Maintenance of Surface Areas .....	1-4	1-1
	Safety.....	1-5	1-3
2.	SUBGRADES, SUBBASES, AND BASES		
	Pavement Types .....	2-1	2-1
	Subgrade .....	2-2	2-1
	Subbase .....	2-3	2-3
	Base Course.....	2-4	2-3
	Materials for Subbases and Base Courses.....	2-5	2-3
	Construction and Repair Procedures.....	2-6	2-5
3.	BITUMINOUS PAVEMENTS		
	Pavement Structure .....	3-1	3-1
	Types of Bituminous Surfaces.....	3-2	3-1
	Causes of Bituminous Pavement Distress.....	3-3	3-3
	Types of Bituminous Pavement Distress .....	3-4	3-7
	Bituminous Pavement Materials.....	3-5	3-16
	Bituminous Pavement Equipment.....	3-6	3-21
	Bituminous Repair Methods.....	3-7	3-32
4.	CONCRETE PAVEMENTS		
	Methods and Procedures .....	4-1	4-1
	Properties and Behavior .....	4-2	4-1
	Causes of Concrete Pavement Distress.....	4-3	4-5
	Types of Concrete Pavement Distress .....	4-4	4-10
	Concrete Pavement Materials.....	4-5	4-20
	Concrete Pavement Equipment .....	4-6	4-22
	Methods of Concrete Maintenance and Repair.....	4-7	4-27
5.	MISCELLANEOUS SURFACES		
	Maintenance and Repair.....	5-1	5-1
	Types of Surfaces and Materials .....	5-2	5-1
	Causes of Distress .....	5-3	5-7
	Types of Distress.....	5-4	5-7
	Methods for Maintenance and Repair .....	5-5	5-7
6.	SHOULDERS AND ROADSIDES		
	Shoulders .....	6-1	6-1
	Types of Shoulder Surfaces .....	6-2	6-1
	Geometrics .....	6-3	6-1
	Types and Causes of Shoulder Distress .....	6-4	6-1
	Methods of Shoulder Repair .....	6-5	6-2
	General Maintenance.....	6-6	6-3
7.	DRAINAGE OF PAVEMENTS		
	Drainage Control.....	7-1	7-1
	Types of Drainage Systems.....	7-2	7-1

\*This manual supersedes TM5624/NAVFAC DM MO-102/AFM 85-8, 31 March 1977, and AFM 88-6, Chap 10, January 1989.

CHAPTER		Paragraph	Page
7.	Types and Causes of Drainage Related Distress .....	7-3	7-4
	Methods for Maintenance and Repair of Drainage Structures .....	7-4	7-5
8.	MAINTENANCE AND REPAIR OF BRIDGE SURFACES		
	Introduction .....	8-1	8-1
	Types of Bridge Surfaces .....	8-2	8-1
	Types and Causes of Bridge Surface Distress .....	8-3	8-1
	Methods for Maintenance and Repair of Bridge Surfaces .....	8-4	8-1
9.	SNOW AND ICE CONTROL		
	Trafficked Area Requirements .....	9-1	9-1
	Properties of Snow and Ice .....	9-2	9-1
	Equipment for Snow and Ice Control .....	9-3	9-2
	Snow Control and Removal .....	9-4	9-4
	Ice Control and Removal .....	9-5	9-16
10.	PREVENTATIVE MAINTENANCE		
	Rational for Maintenance .....	10-1	10-1
	Inspection and Records .....	10-2	10-1
	Maintenance Strategies and Performance of Paved Roads .....	10-3	10-2
APPENDIX	A. REFERENCES .....		A-1
GLOSSARY	.....		Glossary-1
INDEX	.....		Index-1

**List of Figures**

FIGURE		Page
1-1.	Transmission of Wheel Loading to Subgrade .....	1-2
1-2.	Typical Cross-sections of Surfaced Areas .....	1-3
3-1.	Alligator Cracks .....	3-7
3-2.	Bleeding .....	3-8
3-3.	Block Cracking .....	3-8
3-4.	Sag in Asphalt Pavement .....	3-9
3-5.	Corrugation .....	3-9
3-6.	Depression .....	3-10
3-7.	Edge Cracking .....	3-10
3-8.	Transverse Reflective Crack .....	3-11
3-9.	Lane/Shoulder Drop-off .....	3-11
3-10.	Transverse Crack .....	3-12
3-11.	Utility Cut Patching .....	3-12
3-12.	Polished Aggregate .....	3-13
3-13.	Potholes .....	3-13
3-14.	Railroad Crossing .....	3-14
3-15.	Raveling .....	3-14
3-16.	Rutting .....	3-15
3-17.	Shoving .....	3-15
3-18.	Slippage Cracks .....	3-16
3-19.	Swelling .....	3-16
3-20.	Weathering .....	3-17
3-21.	Raveling from Fuel Spills .....	3-17
3-22.	Grooved Asphalt Concrete Pavement .....	3-18
3-23.	Motorized Vacuum Broom .....	3-22
3-24.	Motorized Circular Broom .....	3-22
3-25.	Applying a Seal Coat with Squeegees .....	3-23
3-26.	Hand-held Saw .....	3-23
3-27.	Cutting Disk .....	3-24
3-28.	Removing Damaged Pavement with a Jack Hammer .....	3-24
3-29.	Propane Joint Heater .....	3-25
3-30.	Heater Scarifier with Blade and Spreader Attachments .....	3-25
3-31.	Scarified and Bladed Bituminous Material Being Immediately Respread and Compacted .....	3-26
3-32.	Heater Remixer for In-place Recycling .....	3-26
3-33.	Cold Milling Machine .....	3-27
3-34.	Self-propelled Pavement Milling Machine .....	3-27

FIGURE		Page
3-35.	Traveling Hammer Mill.....	3-28
3-36.	Closeup of Hammer Mill Breaking Shaft.....	3-28
3-37.	Closeup of Pulverizer Mixing Blades.....	3-29
3-38.	Portable Hot-Mix Plant.....	3-29
3-39.	Bituminous Distributor.....	3-30
3-40.	Asphalt Kettle.....	3-30
3-41.	Self-propelled Aggregate Spreader.....	3-31
3-42.	Slurry Seal Machines.....	3-31
3-43.	Asphalt Paving Machine.....	3-32
3-44.	Vibratory Plate Compactor.....	3-32
3-45.	Steel-wheel Tandem Roller.....	3-33
3-46.	Rubber-tired Roller.....	3-33
3-47.	Steel-wheel Vibratory Roller.....	3-34
3-48.	Hole to be Patched With Tack Applied.....	3-35
3-49.	Placing Asphalt Mix in Patch.....	3-35
3-50.	Placement of AC Backfill in Deep Depression.....	3-36
3-51.	Permanent Repair of Potholes.....	3-36
3-52.	Applying Rejuvenator.....	3-37
4-1.	Pavement Failures.....	4-2
4-2.	Age-strength Relationship.....	4-3
4-3.	Approximate Bending Strength.....	4-8
4-4.	Curling.....	4-10
4-5.	Blowup/Buckling.....	4-11
4-6.	Corner Break.....	4-11
4-7.	Divided Slab.....	4-12
4-8.	D Cracking.....	4-12
4-9.	Faulting.....	4-13
4-10.	Joint Seal Damage, Incompressibles in Joint.....	4-13
4-11.	Lane/Shoulder Dropoff.....	4-14
4-12.	Linear Cracking.....	4-14
4-13.	Utility Cut Patch.....	4-15
4-14.	Small Patch.....	4-15
4-15.	Polished Aggregate.....	4-16
4-16.	Popouts.....	4-16
4-17.	Pumping.....	4-17
4-18.	Punch Out.....	4-17
4-19.	Railroad Crossing.....	4-18
4-20.	Scaling.....	4-18
4-21.	Crazing.....	4-19
4-22.	Shrinkage Crack.....	4-19
4-23.	Corner Spalling.....	4-20
4-24.	Joint Spalling.....	4-21
4-25.	Water-cooled Power Saw.....	4-23
4-26.	High-pressure Water Hose.....	4-23
4-27.	Blowing out Dirt from Joints.....	4-24
4-28.	Joint Plow.....	4-25
4-29.	Vertical Router Spindle.....	4-25
4-30.	Vertical Impact Routing Device.....	4-26
4-31.	and Blasting Joints.....	4-26
4-32.	Applying Crack Sealer with a Pouring Pot.....	4-27
4-33.	Applying Joint Material.....	4-28
4-34.	Prepared Partial-depth Patch.....	4-28
4-35.	Completed Patch.....	4-29
4-36.	Patching Near Joint or Pavement Edge.....	4-30
4-37.	Full-depth Patch with Dowel Bars at Edges.....	4-30
4-38.	Cleaning Patch Area with Compressed Air.....	4-31
4-39.	Placing Reinforcement and Dowels in Area to be Repaired.....	4-31
4-40.	Placing Concrete in Patch Area.....	4-32
4-41.	Finishing Surface of Concrete Patch.....	4-32
4-42.	Proper Location of Holes Depending on Defect to be Corrected.....	4-36
5-1.	Gradation Triangle for Aid in Selecting a Commercial Stabilizing Agent.....	5-4
5-2.	Dust Created by a Passing Vehicle.....	5-8
5-3.	Cultivator Mixing Soil.....	5-9
5-4.	Pulvermixer.....	5-9
5-5.	Grader Leveling Road Surface.....	5-10
5-6.	Sheepsfoot Roller.....	5-10

FIGURE		Page
5-7.	Rubber-tired Roller .....	5-11
5-8.	Vibratory Roller .....	5-11
5-9.	Regrading and Rolling Road Surface .....	5-12
5-10.	Hand Spreading Bags of Cement .....	5-13
5-11.	Spreading Lime with a Harrow .....	5-13
5-12.	Spreading Cement Directly from Bulk Carrier .....	5-14
5-13.	Dry Mixing Cement with Pulverizer .....	5-14
5-14.	Adding Water to the Soil .....	5-15
5-15.	Finish Rolling with a Rubber-tired Roller.....	5-15
5-16.	Spraying Lime from a Tank Truck and Immediately Mixing Treated Soil .....	5-16
7-1.	Typical Subdrain Installation .....	7-2
7-2.	Concrete Open Drainage Ditch.....	7-3
7-3.	Concrete Flume for Discharging Water into Drainage Channel.....	7-3
7-4.	Types of Scour at Culvert Outlets.....	7-4
7-5.	Ditch Check .....	7-5
7-6.	Slide Failure or Collapses of a Steep Slope .....	7-6
7-7.	Relatively Mild Side Slopes and Good Vegetative Cover.....	7-7
7-8.	Headwall at Inlet to Culvert Passing Beneath a Railroad Bed .....	7-8
7-9.	Barred Concrete Endwall for Conveying Runoff .....	7-8
7-10.	Recommended Riprap Sizes .....	7-9
7-11.	Riprap Placed along a Drainage Channel for Protection Against Erosion.....	7-10
7-12.	Wood and Rock Fencing for Control of Erosion .....	7-11
7-13.	Rock Fences for Control of Erosion.....	7-11
7-14.	Grated Inlet.....	7-12
8-1.	Exposed Reinforcing Steel.....	8-2
9-1.	Reversible Blade Mounted on a 1/4-ton Utility Truck.....	9-3
9-2.	Two-element Rotary Plow with Twin Horizontal-axis Helical Augers.....	9-4
9-3.	Belt Conveyor Unit for Truck Loading Snow .....	9-5
9-4.	Towed Power Rotary Broom with High-Volume Low-pressure Airblast .....	9-6
9-5.	Small Tracked Vehicle with V-blade Towing a Sand Spreader .....	9-7
9-6.	Combination Applicator.....	9-8
9-7.	Simplified Impression of Eddies Formed by Typical Obstructions.....	9-9
9-8.	Snowdrifts Generated by Solid Snow Fences and by Vertical Slant Fences of Various Densities.....	9-10
9-9.	Basic Arrangements of Snow Fences for Protecting Roads or Railroads.....	9-11
9-10.	Vertical Slat Fence.....	9-12
9-11.	Fence Made by Stapling Strips of Reinforced Paper or Plastic Strips onto Wooden Posts.....	9-12
9-12.	Inclined Slat Fences .....	9-13
9-13.	Trellis Fence .....	9-13
9-14.	Old Style Russian Snow Fence .....	9-14
9-15.	Snow Block Fence .....	9-14
9-16.	Shelterbelt or Living Snow Fence.....	9-15

**List of Tables**

TABLE		Page
2-1.	Select Materials and Subbases .....	2-3
2-2.	Characteristics and Ratings of Unified Soil System Classes for Soil Construction .....	2-6
3-1.	Pavement Distress Types and Maintenance and Repair Alternatives.....	3-4
3-2.	Possible Causes and Types of Imperfections in Finished Pavements.....	3-6
3-3.	Grade Classification .....	3-20
3-4.	Mixing Temperatures .....	3-20
4-1.	Approximate Mixing Water Requirements for Different Slumps and Maximum Sizes of Aggregates .....	4-4
4-2.	Recommended Slumps for Various Types of Construction .....	4-5
4-3.	Suggested Trial Mixes for Air-entrained Concrete of Medium Consistency .....	4-6
4-4.	Suggested Trial Mixes for Nonair-entrained Concrete of Medium Consistency .....	4-7
4-5.	Pavement Distresses and Suggested Maintenance and/or Repair Procedures.....	4-9
9-1.	Chemical Application Rates for Roads .....	9-18
9-2.	Ice-dissolving Capacity of Urea, Pounds per Square Yard .....	9-19
9-3.	Freezing Point of Isopropyl Alcohol-water Mixtures .....	9-20

## CHAPTER 1

## GENERAL

**1-1. Purpose**

This manual provides guidance for all Army, Navy, and Air Force installation personnel engaged in the maintenance and repair of surfaced areas and related structures. It is intended to be practical and concise and useful to foremen as well as engineers.

**1-2. Scope.**

This manual provides guidance for effective maintenance and repair of roads, streets, parking and open-storage areas, walks, airfields, and similar traffic areas at Army, Navy, and Air Force installations. Methods used in accomplishing maintenance and repair work are described. Navy policy in these areas is given in OPNAVINST 11010, 20E. The materials, methods, and equipment cited in this manual represent the most predominate types used in the construction industry. Locally available materials, methods, or equipment not cited in this manual can be used when experience warrants. The text includes general principles of maintenance and repair for use by all activities designated to maintain pavements in a condition suitable for their intended use. The servicing functions of sweeping, snow removal, and ice control described in this manual are applicable to the Army and Navy activities only.

**1-3. References**

Appendix A contains a list of references used in this document.

**1-4. General principles for maintenance of surface areas**

Pavements are usually classified as flexible (bituminous concrete surface) or rigid (portland cement concrete surface). Natural soils are not usually suitable for heavy vehicular traffic or any great volume of vehicular or pedestrian traffic. The simplest types of surfaced areas are those in which coarse materials are added to fine-grained soils, fine soil binders are added to coarse-grained soils, or a waterproofing agent is applied to the surface of naturally stable soils. Heavy loads require surfaced areas that are strong and thick enough so that the transmitted load does not exceed the load-bearing capacity of the subgrade soil. Figure 1-1 shows the general principle of transmission of wheel loads to the subgrade. Unit pressures transmitted to the surface are approximately equal to the tire pressure. Greater surfaced area thickness is required over subgrades having lower bearing capacity than

over subgrades having higher bearing capacity. Figure 1-2 shows typical cross sections of surfaced areas.

*a. Surface areas.* Surface areas includes all pavements and miscellaneous or stabilized (other than grass) areas used for vehicular, aircraft, or pedestrian traffic (such as roads, streets, service drives, walks, parking areas, open storage, and airfield paved areas).

*b. Standards of maintenance and repair.* The basic objectives of the standards outlined in this manual are to maintain surfaced areas in an economical manner that will protect the Government's investment, reduce to a minimum the hazards to life and property, and permit continuous use. The concept of standards of maintenance and repair will vary depending on whether the repairs are of an emergency nature with a short life expectancy, semipermanent, or permanent. The quality of the materials used and the thoroughness of the repair will depend on the nature of the repair. Prompt and adequate maintenance is of paramount importance. The general maintenance principles below shall be observed.

(1) *Prompt maintenance.* Once deterioration or destruction of a surface has started, it can proceed very rapidly. A minor maintenance job postponed can thus develop into a major job involving base, subbase, and subgrade as well as surface. Therefore, timely and adequate inspection and maintenance are essential.

(2) *Priority.* Priority in making repairs depends on operational requirements, traffic intensity, and consideration of the hazards that would result from complete failure.

(3) *Traffic interference.* Maintenance and repair work shall be scheduled to minimize interference with essential traffic. Whenever feasible, the work shall be planned and performed to permit at least partial or limited use of the facility. When it is necessary to completely close a facility, plans shall be made for alternate operational areas, and the work shall be done in the least possible time. When a facility is to be partially or completely closed, every effort will be made to publicize the closure several days in advance. Media that can be used include base newspapers, daily bulletins, and base radio stations.

(4) *Basic causes.* Surface repair without correction of a faulty subgrade, subbase, or base only temporarily corrects a poor condition, necessitating further maintenance and repair at a later date.

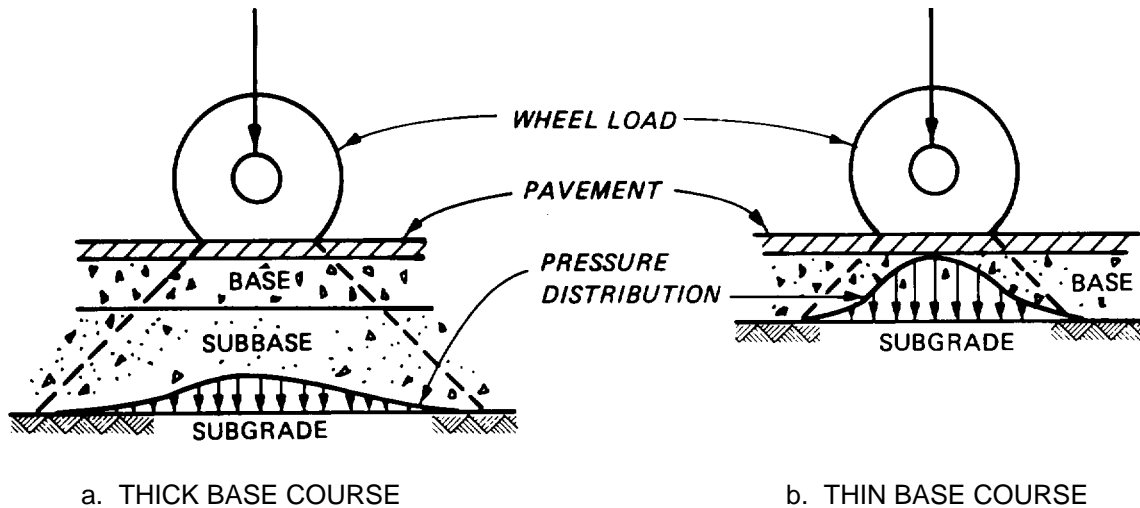


Figure 1-1. Transmission of wheel loading to subgrade.

Explorations to determine the cause of failure and action to eliminate the cause as well as to repair apparent damage are considered basic requirements.

(5) *Uniformity.* Maintenance and repair of existing surfaces will conform as closely as possible to the original construction in design, material, strength, appearance, and texture. A uniform pavement is easier to maintain.

(6) *Overloads.* Surface areas subjected to extensive overloading eventually require reconstruction and/or strengthening. Repairs to such areas will involve only minimum work necessary to keep them in operating condition until overall corrective measures are taken.

(7) *Usage.* The extent of maintenance, repair, and rehabilitation of surfaced areas will be governed by the anticipated use. Routine maintenance will be based on a continuing long-term planned program at each activity. On land that is held under lease, permit, or easement, the terms of such document will be taken into consideration when the extent and type of maintenance, repair, and rehabilitation are determined.

*c. Selection and sampling of materials.* Proper planning and selection of materials as well as methods of operation will determine to a large extent the efficiency of the methods of pavement maintenance.

(1) *Inspection and sampling.* Field inspections and tests are generally adequate for the selection of soils and aggregates, control of gradation, and the proportioning of bulk materials during the progress of the work. The inspections also serve as a basis for accepting or rejecting processed or manufactured materials. Laboratory tests are needed to determine the physical and chemical properties of materials. These tests may be performed by laboratories of the

Air Force, Naval Districts Public Works Offices, Corps of Engineers Division and District offices, State highway department, or by commercial firms especially equipped for this purpose.

(2) *Material survey.* Surveys will be made to determine the location, nature, and cost of all natural and processed materials available locally and/or from nearby commercial sources. Complete information about these materials will be obtained and kept on file for future use. Frequently, maintenance and repair work may be accomplished with local materials either in their natural state or screened, crushed, or blended. The use of these local materials results in savings in man- and equipment-hours, transportation, and money.

*d. Surfaced area inspection.* A comprehensive maintenance program will be developed and aggressively executed in order to lengthen pavement life and reduce maintenance and repair problems and costs. Frequent pavement inspections can detect early evidence of defects before actual failure occurs. Frequent inspections should be semiannually or annually depending on the type of surfaces and local climatic or operational conditions. Seasonal inspections of drainage systems will be made. At least twice a year, subsurface drains will be examined to make sure that they are working properly. Drainage inspections should be made during rainy seasons, spring thaws, and immediately following heavy storms. Most potential failures such as cracking, undermining, poor drainage, pumping of slabs, and progress of weathering action may be found through detailed inspections, examination, and testing. Inspection should be conducted by competent personnel to ensure that deficiencies are properly identified and reported.



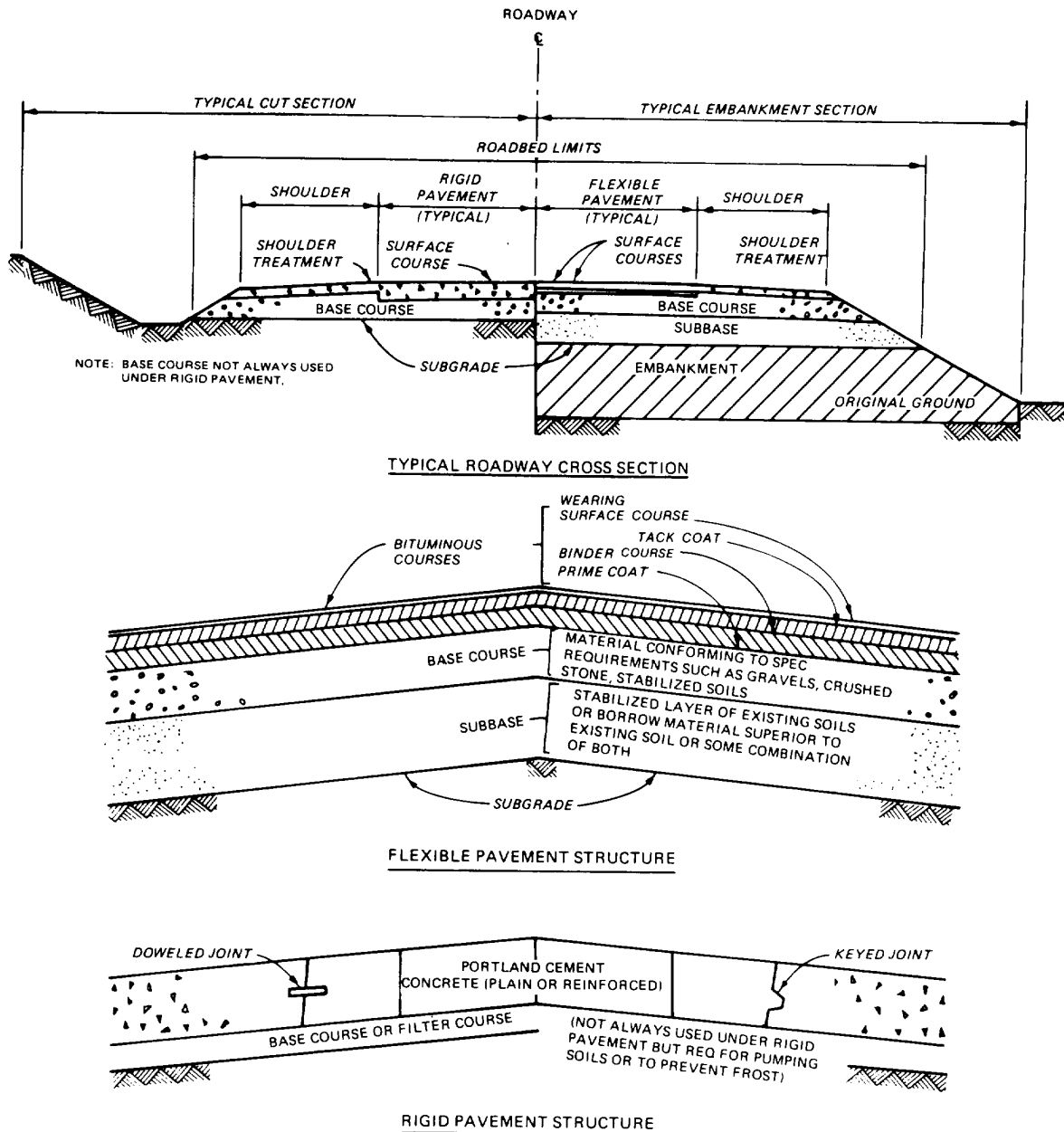


Figure 1-2. Typical cross-sections of surfaced areas.

e. *Overlay.* In areas where surface drainage can be maintained, the use of overlays is often economical and advantageous. An overlay is used to increase the strength of the pavement structure and to improve the quality of the surface.

f. *Reconstruct and/or recycle.* Reconstruction and/or recycling should be considered when the pavement has deteriorated to a condition where normal repair procedures are no longer feasible. Recycling of pavements as either base or surface

materials can be economical when compared to reconstruction with virgin material. The various methods and types of recycling should be considered to determine the most cost effective alternative for a particular pavement.

**1-5. Safety**

Personal protective clothing will be issued at the option of the Base or Post Civil Engineer to ensure the health and safety of Civil Engineering personnel.

Protective clothing includes, but is not limited to, coveralls, goggles, respirators, protective headgear, and steel-toed shoes that may be required in performing the work addressed in this manual.

*a. Equipment.* Selected equipment will be used when personnel are engaged in handling or placing hot tar, hot asphalt, acids, caustics, creosoted materials, and other liquids that are hazardous. Selected equipment will also be used in sledging, hammering, or chipping on concrete, stone, or metal; and in

handling heavy and sharp-edged or abrasive materials. Reflective vests should be available for all personnel when working in traffic areas.

*b. Signs and markings.* Safety signs and markings, such as traffic guides, road and runway markings, safe load limits of bridges and culverts, and maximum clearances of overhead structures will be kept clear and legible. Control devices will be operated to the extent necessitated by the traffic involved.

## CHAPTER 2

**SUBGRADES, SUBBASES, AND BASES****2-1. Pavement types**

There are two basic pavement types discussed in this manual. Subgrade, subbases, and bases are also discussed as they relate to the two types of pavements.

*a. Flexible pavement.* Flexible pavement consists of the subgrade or natural in-place soil, select material or subbases, the base course, and the asphalt pavement surface. Base courses and subbases for flexible pavements are placed to distribute the surface-induced stresses from the vehicle and aircraft wheel loads so that the resulting stresses on the subgrade do not exceed its strength (fig. 1-1). The subgrade ultimately supports the load placed on the surface of the pavement, and the strength of the subgrade partially determines the thickness of pavement structure (surface, base, and subbase). Information for flexible pavements is provided in TM 5-825-2/AFM 88-6, chapter 2, section A/NAVFAC DM-21.3.

*b. Rigid pavement.* Rigid pavement consists of the subgrade or natural in-place soil, any aggregate courses, and the portland cement concrete slabs. Aggregate courses under concrete slabs are not always used but are generally provided to prevent water migration or pumping, or to minimize frost action. Concrete slabs are designed to distribute the stresses from the wheel loadings over large areas. However, concrete slab stresses (and deflections) at free edges will be higher than stresses in the middle of slabs. Hence, load transfer is a must. In continuously placed unreinforced concrete, contraction joints are placed at a uniform spacing based on the thickness of the pavement, and load transfer is obtained by interlocking the concrete aggregate. Transfer devices such as dowels or keys are used to transmit loads between slabs at butt or fully formed joints and at construction joints in reinforced concrete. Where transfer devices are not used or strengthening by extra steel along edges is not used, provision for slab edge support is made by using a cement-treated base under slabs or by thickening the concrete at the edges of the slab. Strong foundation materials beneath concrete slabs result in a reduced slab design thickness as compared with the thickness that would be required for a weak foundation.

*c. Effects of water on foundation soils.* Saturation of pavement bases and subgrades generally decreases their load-carrying capacity. Failures as a result of saturation may be minimized by preventing infiltration of surface water into the base or

subgrade and by removing excess moisture or trapped water from beneath the pavement. Infiltration of surface water can be prevented by sealing large cracks and periodic application of surface seals to bituminous pavements, by replacing ineffective sealers in joints of concrete pavements, and by proper drainage of surface water from the pavement area. In areas of high water tables under pavements, properly designed subsurface drainage, stabilized bases, or free-draining materials that are not adversely affected by moisture are required. In areas where frost is a consideration, selected materials, as required by specifications, are needed to limit frost penetration and subsequent frost heave or weakening of materials during the frost melting period.

**2-2. Subgrade**

The subgrade is the natural in-place soil under a pavement. In general, compaction increases the strength of most soils; however, there are a few soils (some clays and silts) that decrease in stability when scarified, worked, and rolled. There are also some soils that shrink excessively during dry periods and expand excessively when allowed to absorb moisture. When these soils are encountered, special treatment is required. Unsuitable soils that will not support equipment used in maintenance or repair operations will be stabilized or removed and replaced with more suitable soils. Unsuitable subgrade soils under a failed pavement will be repaired or removed and replaced prior to other correction action.

*a. Clays.* The types of clays that show a decrease in strength when scarified and rolled are generally organic and inorganic clays having high plasticity and organic silts. These materials are classified in the CH and OH groups according to ASTM D 3282. These materials are clays that have been consolidated to a very high degree, either under an overburden load or by alternate cycles of wetting and drying, or by some other means and thus have developed a finite structure. They have a high strength in the undisturbed state. Scarifying, reworking, and rolling these soils in cut areas may produce a lower bearing strength than that of the undisturbed soils. When the undisturbed soil has a higher bearing value than in a disturbed state, then no compaction will be attempted, and construction operations will be conducted to produce the least possible disturbance of the soil.

*b. Silts.* Experience has shown that some deposits of silt, very fine sand, and rock flour (predominantly

having a USCS classification of ML an SC) (ASTM D 2487), when compacted in the presence of a high water table, will pump water to the surface and become "quick" or "spongy" with loss of strength. This condition can also develop in most silts and poorly drained very fine sands if these materials are compacted at a high moisture content, because the compaction reduces the air voids so that the available water fills practically all the void space. Drying is not difficult if the source of moisture can be removed since the soils are usually friable and can be scarified readily. In cases of high water table, drying is usually not satisfactory until the water table is lowered because recompacting operations will again cause water to be pumped to the surface. Local areas of this nature are usually treated satisfactorily by replacing the soil with subbase and base materials or with a dry soil insensitive to water. Where drainage is not feasible and a high water table cannot be lowered, every effort will be made not to disturb the subgrade. Also, additional thicknesses of base and pavement surface layers will be used to ensure that the subgrade will not be overstressed or compacted during subsequent traffic by vehicle or aircraft.

*c. Expansive soils.* Soils with expansive characteristics occur universally, and local determinations must be made. Extensive trouble occurs in certain areas of the West Gulf Coastal Plains and the Great Plains where climatic conditions are conducive to significant changes in moisture content of the subgrade during different seasons of the year. Such soils also give trouble in any region where construction is accomplished in a dry season and the soils absorb moisture during a subsequent wet season. Conversely, problems arise in areas where construction is accomplished in the wet season and the soils lose moisture during the subsequent dry season. If highly compacted, these soils will swell and produce uplift pressures of considerable intensity if the moisture content of the soil increases after compaction. This action may result in intolerable differential heaving of pavements. A common method of treating a subgrade with expansive characteristics is to compact it at a higher moisture content and to maximum unit weight. This solution may be temporary due to reasons given above. Another method of reducing the shrinking or swelling is to use a stabilization method such as lime. Special solutions to the problem of swelling soils are sometimes possible and should not be overlooked where pertinent. For instance, where climate is suitable, it may be possible to place a permeable layer (aquifer) over a swelling soil and limit or prevent drainage from it. Moisture buildup in this layer maintains the soil in a stable, saturated condition.

*d. Blanket/filter courses.* Whenever the subgrade is composed of fine-grained soil and the base course to be placed on it is composed of open-graded crushed rock or gravel, a blanket course of 1 to 2 inches of sand or crusher screenings, or an equivalent geotextile fabric will be placed on the subgrade. This course will be compacted with a rubber-tired or steel-wheel roller. A hand or pneumatic tamper is used if the area is too small for powered equipment. Compaction equipment should not be used directly on geotextiles. This blanket/filter course helps prevent the fine soil from working up into the base under repeated loadings if excess water is present. A blanket course is not necessary if the base material is dense graded.

*e. Frost effects.* In regions where frost may penetrate the subgrade or subbase, frost effects should be anticipated. To minimize damaging effects of frost, maintenance methods will be adjusted from those used in more temperate climates. The most detrimental effects of frost occur during the thawing period when the soil, which has expanded as a result of freezing, becomes saturated and unstable. By following design procedures applicable for construction of pavements in areas with deep frost penetration maintenance problems can be minimized. Procedures should be adjusted to reduce the possibility of damage by differential heaving and frost boils.

(1) *Drainage.* Surface water drains and outlets for subgrade drainage will be kept free of obstructions so that a minimum of moisture reaches the subgrade.

(2) *Repair.* When repairing areas of pavement are affected by frost action, care must be used in selecting materials and methods which will ensure against repeated failure. TM 5-825-2-1/AFM 88-6, chapter 2, section ANAVFAC DM-21.3, and NAVFAC DM-5 discuss the treatment of pavements in frost areas.

*f. Permafrost.* Permafrost is a layer of soil or rock at a variable depth below the surface of the earth in which a temperature below freezing has existed continuously for many years. In the permafrost areas, the greatest maintenance problems occur in the spring and early fall. Preventive measures are similar to those for frost action. Permanent repairs are usually restricted to the summer and must comply with the minimum specification and design used in the original construction. In winter, the major maintenance problem is snow and ice removal (see chap 9). In winter months during inspections, low areas which flood and freeze must be noted so that corrective drainage measures can be carried out during spring and summer maintenance and repair activities. Snowbanks should not be allowed to develop since they act as snow traps. Culverts and drainage

ditches should be cleared of snow by early spring in preparation for the runoff from the thawing snow.

**2-3. Subbase**

For economic reasons, it is common practice in flexible pavement design to use locally available or other inexpensive materials between the subgrade and base course. These layers are designated as subbases or select materials. The use of subbase or select materials will permit a reduced thickness of base course material, normally a more costly material. The specification requirements for subbase materials are more restrictive than those for select materials. Because of this, subbase materials are limited to a design California Bearing Ratio (CBR) greater than 20 while select materials are limited to a design CBR of 20 or less. Therefore, the required pavement and base course thickness will be greater above select materials than for a subbase material. Select materials for pavements may consist of heavy

loads and large volumes (e.g., airfields, primary roads, and highways) and as base courses, low-volume pavements (e.g., secondary roads, range patrol roads, etc.). Select materials and subbases may consist of locally occurring coarse-grained soils or blended and processed soils. Materials such as limerock, coral, shell, ashes, cinders, caliche, and disintegrated granite may be used when they are economical and when they meet the requirements set forth in table 2-1. These requirements are imposed to ensure the use of materials that can be readily processed and will meet the strength requirements. Material stabilized with commercial admixes may be economical as a subbase in certain instances. Also, by using sufficient amounts of lime, portland cement, or fly ash, it may be possible to decrease the plasticity of some materials making them suitable as subbases. Stabilization of materials is discussed in chapter 5.

Table 2-1. Select materials and subbases

Material type	Maximum size Aggregate (inches)	Maximum percentage no. by weight of material passing the no. 200 sieve	Material passing the 40 sieve	
			Liquid index	Plasticity index
Select material	3	25	<35	<12
Subbase material	3	15	<25	<5

**2-4. Base course**

Experience has shown that high-quality materials must be used in the base course (the layer directly beneath the pavement surface layer). For flexible pavements, a low subgrade strength requires a substantial thickness of select material, subbase, and base material to reduce the imposed stress on the subgrade. Where the subgrade strength is high, only a base course may be required to provide for adequate load distribution. Since the stresses in the base courses are always higher than those in the subgrade, the base course must have a higher strength than the subgrade and be sufficiently compacted to prevent consolidation under traffic. For both flexible and rigid pavements, select materials, subbases, and base courses provide the following functions: (a) additional structural strength, (b) more uniform bearing surface for the pavement, (c) replacement for soft highly compressible or expansive soils, (d) protection for the subgrade against detrimental frost action, (e) drainage and prevention of pumping, and (f) suitable surface for the operation of construction equipment during adverse weather conditions. Positive drainage will be provided for all base courses to ensure against water being trapped and saturating the layers. Saturated

layers reduce pavement strength and promote the pumping condition that the base course is designed to prevent.

**2-5. Materials for subbases and base courses.** A wide variety of gravels, sands, gravelly and sandy soils, and other natural materials such as limerock, coral, shells, and caliche are used alone or blended to provide satisfactory select material, subbase, or base course. Natural materials often require crushing or removal of the oversize fraction to maintain gradation limits. Other natural materials may be controlled by mixing crushed and pit-run materials together to form a satisfactory select material, subbase, or base course material. These materials are occasionally used without further surfacing, but they usually require constant maintenance to correct for traffic wear, prevent dusting, and minimize infiltration of surface waters.

a. *Gravel and sand.* Many natural deposits of sandy and gravelly materials make satisfactory select material, subbase, and base courses. Gravel deposits vary widely in the relative proportions of coarse and fine material and in the character of the rock fragments. Satisfactory select materials, subbases, or base materials can be produced by blending

materials from two or more deposits. Clean washed gravel alone is unsatisfactory for a select material, subbase, or base course because fine material which acts as the binder and fills the voids between the coarser aggregate is needed to provide adequate shear resistance. A binder material will be added to the material if needed; however, care will be taken so that fines meet the plasticity requirements for a select material, subbase, or base material. Addition of clay fines to a washed gravel may cause the material to become unstable with increases in moisture content. A base course made from sandy and gravelly materials would normally have a high shear strength and could be used to support heavy loads.

*b. Sand-clay.* Natural deposits suitable for mixtures may be found in alluvial deposits of varying thickness. Often there are great variations in the proportions of sand and clay from top to bottom of a pit. With proper proportioning and construction methods, sand-clay mixtures will make satisfactory base courses for secondary type roads. This material is most often used for select material and subbase courses in stage construction where higher quality materials are to be added later. This type of material should be investigated to assure that the clays are not highly plastic or swelling clays.

*c. Processed materials.* Processed materials are prepared by crushing and screening rocks, gravel, or slag. A properly graded crushed rock base produced from sound durable rock particles makes the highest quality base materials. Crushed rock may be produced from any rock that is hard enough to require drilling, blasting, and crushing. Existing quarries, ledge rock, slag, cobbles and gravel, talus deposits, coarse mine tailings, and similar hard durable rock fragments are the usual source of processed materials. Materials which slake on exposure to air or water should not be used. Processed materials are normally more expensive than readily available gravels or sand-clays.

(1) *Composite base materials.* A composite base material is one in which all the materials ranging from coarse to fine are intimately mixed either before or as the material is laid in place. Because the aggregate obtained from deposits such as those produced in crushing operations is often deficient in fines, it may be necessary to blend in select fines to obtain a suitable gradation. Screenings, crusher run fines, or natural soil may be added and mixed either in the processing plant or during the placing operation. Where a soil is used, care will be taken to limit the clay content so that the plasticity index of the blended material will not exceed specification requirements.

(2) *Macadam-type base.* A macadam-type base material is composed of uniformly crushed rock, gravel, or slag. The term "macadam" is usually applied where the coarse aggregate is placed and rolled, and then fine aggregate or screenings are placed and rolled and broomed into the coarse aggregate until it is thoroughly keyed in place. This is commonly referred to as dry-bound macadam. Water may be used in the compacting and keying processes, and this is then referred to as water-bound macadam. Any hard durable crushed aggregate can be used provided the coarse aggregate is primarily of uniform size and the fine aggregate will key into the coarse aggregate. This type of base is rarely used in modern maintenance operations.

*d. Recycled materials.* Recycled materials will consist of broken up asphaltic concrete (AC) or portland cement concrete (PCC). These materials are obtained by utilizing a milling machine or by full-depth breakup and removal of the pavement. The milling machine provides a material which is directly usable while the broken up material generally requires further processing or crushing. Reinforcing in PCC will negate the use of a milling machine. Recycled materials can fulfill the same requirements as new materials and usually at reduced costs.

*e. Other materials.* In many geographical areas, deposits of natural sands and gravel and sources of crushed rock are not available. This has led to the development of select material, subbase, or base courses from materials that normally would not have been considered. These include caliche, limerock, shells, cinders, coral, iron ore rubble, and other select materials. Some of these are primarily soft rocks that crush under construction traffic to produce a composite select material, subbase, or base material similar to those described in paragraph 2-5c. Others develop a cementing action which results in a satisfactory select material, subbase, or base. These materials cannot be judged on the basis of the gradation limits used for other materials, but instead, they must be judged on the basis of service behavior. Strength tests on laboratory samples are not satisfactory because the samples prepared in the laboratory seldom duplicate the material in place. The plasticity index is a reasonably good criterion, and, as a general rule, a low plasticity is a necessity. Observations of the performance of these materials in existing pavements provide the most reliable clues to whether they will perform satisfactory on future projects. Consultation with local engineers who have had experience in the use of these local materials will prove beneficial.

(1) *Coral*. This material is commonly found in the Pacific and Caribbean areas. Uncompacted coral has a high capillarity, and if poorly drained, its moisture content is normally above optimum, and the material does not have a high degree of stability. The bonding properties of coral provide its greatest asset as a construction material. The bonding properties vary with the calcareous content, proportion of fine and coarse materials, age, length of exposure to the elements, climate, traffic, sprinkling, and method of compaction. Proper moisture control, drainage, and compaction are essential to obtain satisfactory results.

(2) *Caliche*. One of the most common characteristics of caliches which make many of them valuable for select material, subbase, or base courses is their capability of recementation when saturated by water, subjected to compaction, or given a "setting" period. This is especially true of caliches which are cemented with lime, iron oxide, or salt. Caliche is variable, in both mineral content (limestone, silt, and clay) and degree of cementation. This accounts for widespread differences of opinion as to its suitability for road or airfield construction. Therefore, it is important that caliche of good uniform quality be selected from available deposits and that it be compacted at optimum moisture content. After caliche has been slaked for 72 hours, the liquid limit of the fines must not exceed 34 and the plasticity index 10. For base material, caliche will generally be crushed to meet the following gradation: maximum size of 2 inches, 15 to 35 percent passing the No. 40 sieve, and from 0 to 20 percent passing the No. 200 sieve. Where the construction is to be made on surface deposits, undesirable material should be removed by stripping operations.

(3) *Tuff*. Tuff is a term applied to compacted deposits of the fine materials ejected from volcanoes such as cemented dust and cinders. Tuffs, prevalent in the Mediterranean area, are more or less stratified and in various states of consolidation. Tuff and other cementitious materials of volcanic origin may be used for select material, subbase, or base courses. Tuff bases are constructed in a manner similar to other base courses. After the tuff is dumped and spread, the oversize pieces are broken and the base compacted.

## 2-6. Construction and repair procedures

The materials used to repair a subbase or base course should meet or exceed the requirements of the existing material. The following are mixing and placing procedures applicable to both subbase and base courses.

a. *Mixing*. Uniform mixing and blending of materials are essential for durability. Materials can be mixed in the pit with either excavating equipment or in a stationary plant. Materials can also be blended and mixed on site by scarifiers, plows, graders, or tillers. During the mixing, the materials are spread evenly in correct proportions with the finer material on top. Initial mixing to work the fines into the coarse material may be accomplished with grader-scarifier attachment or with harrows. Final mixing is accomplished with a rotary tiller or a grader. When a grader is used, the materials are thoroughly mixed by alternately blading the entire layer to the center and back to the edges of the working strip. During compaction, water content should be maintained in the material within range of the optimum water content. The required water content can be obtained by rewetting the material if too dry and by blading and aerating if too wet.

b. *Placing*. Areas to be repaired, when possible, should use existing work for control of surface grades and linear placement. Larger areas usually require grade stakes and forms be used to ensure proper surface gradients as well as to identify limits of work. Trucks, scrapers, and other hauling vehicles can be used to deposit material directly on the subgrade. Mechanical spreaders or controlled tailgate openings help to govern the rate of spread from trucks. On areas large enough to accommodate them, spreading can be accomplished by dozer or grader blading. On smaller areas materials can be placed and spread by hand.

c. *Compacting*. Subbase and base course layers containing gravel and soil-binder material are compacted with steel-wheel, rubber-tired vibratory compactors. Equipment and methods should be adjusted on each job to suit the characteristics of the material. Table 2-2 gives more information concerning compaction equipment and other characteristics for various soil types.

d. *Finishing*. Finishing operations will closely follow compaction to furnish a crowned, tight, water-shedding surface. A grader is used for finishing graded aggregate bases. The material is bladed from one side of the operation area to the middle and back to the edge until the required lines and grades are obtained. Before final rolling, the bladed material will be at its optimum moisture content so that it can be compacted to maximum density. If proper compaction is not obtained, thin layers of the material may peel from the underlying layer.

Table 2-2. Characteristics and ratings of unified soil system classes for soil construction

Class	Compaction Characteristics	Maximum-Standard Proctor		Compressibility and Expansion	Drainage and Permeability
		Dry Density (tons/m <sup>3</sup> )	Unit Weight (lb/ft <sup>3</sup> )		
GW	Good: tractor, rubber-tired, steel wheel, or vibratory roller	2.00-2.16	125-135	Almost none	Good drainage, pervious
GP	Good: tractor, rubber-tired, steel wheel, or vibratory roller	1.84-2.00	115-125	Almost none	Good drainage, pervious
GM	Good: rubber-tired or light sheepsfoot roller	1.92-2.16	120-135	Slight	Poor drainage, semipervious
GC	Good to fair: rubber-tired or sheepsfoot roller	1.84-2.08	115-130	Slight	Poor drainage, impervious
SW	Good: tractor, rubber-tired or vibratory roller	1.76-2.08	110-130	Almost none	Good drainage, pervious
SP	Good: tractor, rubber-tired or vibratory roller	1.60-1.92	100-120	Almost none	Good drainage, pervious
SM	Good: rubber-tired or sheepsfoot roller	1.76-2.00	110-125	Slight	Poor drainage, impervious
SC	Good to fair: rubber-tired or sheepsfoot roller	1.68-2.00	105-125	Slight to medium	Poor drainage, impervious
ML	Good to poor: rubber-tired or sheepsfoot roller	1.52-1.92	95-120	Slight to medium	Poor drainage, impervious
CL	Good to fair: sheepsfoot or rubber-tired roller	1.52-1.92	95-120	Medium	No drainage, impervious
OL	Fair to poor: sheepsfoot or rubber-tired roller	1.28-1.60	80-100	Medium to high	Poor drainage, impervious
MH	Fair to poor: sheepsfoot or rubber-tired roller	1.20-1.60	75-100	High	Poor drainage, impervious
CH	Fair to poor: sheepsfoot roller	1.28-1.68	80-105	Very high	No drainage, impervious
OH	Fair to poor: sheepsfoot roller	1.12-1.60	70-100	High	No drainage, impervious
Pt	Not suitable			Very high	Fair to poor drainage

\* Adapted from Sowers 1979 and TM 3-357.



## CHAPTER 3

## BITUMINOUS PAVEMENTS

**3-1. Pavement structure**

A typical flexible or bituminous pavement structure consists of the following pavement courses: subgrade, subbase, base, and bituminous wearing surface. This section deals with types of bituminous surfaces, types and causes of distress, and methods and materials for repair.

*a. Wearing surface.* The wearing surface is the uppermost layer of the pavement structure. In a flexible pavement, it is a mixture of bituminous binder material and aggregate. The binder may be sprayed on the surface followed by application of aggregate and referred to as a bituminous surface treatment. The binder and aggregate may be mixed in a central plant or mixed in place on the road and referred to as hot or cold mixes. The wearing surface may range in thickness from less than an inch, as in the case of a surface treatment, to several inches of high-quality paving mixture such as hot-mix AC.

*b. Principal functions.* The wearing surface has four principal functions: to protect the base from abrasive effects of traffic, to distribute loads to the underlying layers of pavement structure, to prevent surface water from penetrating into the base and subgrade, and to provide a smooth riding surface for traffic.

**3-2. Types of bituminous surfaces**

Bituminous materials are adaptive to a wide variety of local aggregate. Design procedures include such factors as type, weight, and volume of traffic, climatic conditions, wearing surface aggregate base and subgrade conditions, and availability of materials and funds.

*a. Surface treatments.* Bituminous surface treatments are used for corrective or preventive maintenance of pavement surfaces or as a wearing surface for low volume roads. The use of these treatments is limited to pavements which are structurally adequate since these treatments add no significant strength to the pavement.

(1) *Rejuvenator.* Rejuvenators are especially developed products which can be used to extend the life of bituminous pavements. These products may be sprayed on the pavement surface by use of a conventional asphalt distributor. The rejuvenators penetrate into the bituminous pavement usually to a depth of 1/4-inch and soften the asphalt binder. The use of rejuvenators also help retain surface fines and reduce cracking in pavements. One disadvantage of rejuvenators is the lowering of the pavement's skid resistance. For this reason, the use of rejuvenators on runways or other high speed pavements

must be carefully controlled. When an unacceptably slipper surface results from the application of a rejuvenator, an application of sand may be applied to increase the skid resistance of the pavement surface.

(2) *Fog seal.* A fog seal is a light spray application of asphalt emulsion applied similarly as a rejuvenator. However, the fog seal is not intended to penetrate into the pavement. A fog seal can be used to seal a pavement surface to waterproof and prevent raveling of surface aggregate. Sand may be applied to areas where the fog seal has lowered the pavement's skid resistance below an acceptable level.

(3) *Single- and double-bituminous surface treatments and seal coats.* The purpose of these treatments is to retard pavement raveling and deterioration. They also improve the surface texture and skid resistance and provide a waterproof wear resistance surface. These surface treatments are normally constructed using an emulsified asphalt combined with the required aggregate for the job being constructed.

(4) *Asphalt slurry seal.* A slurry seal is a mixture of slow-setting asphalt emulsion, crushed fine aggregate, mineral filler, and water. The materials are combined in a special portable slurry seal machine to produce a slurry mixture and then applied directly to the pavement surface. This treatment provides an excellent riding surface while sealing the underlying pavement.

(5) *Coal tar seal.* This surface treatment is utilized where the pavement surface is exposed to fuel spillage. The coal tar emulsion seal coats can be applied with or without aggregate depending on requirements. When aggregate is added, this seal can be applied similarly as an asphalt slurry seal.

(6) *Special applications.* Special applications are those treatments which utilize nonbituminous binder materials including any additives used in surface treatments. Epoxy resins and rubber adhesive compounds are examples of nonbituminous binder materials. The additives include the various types of latex rubber additives used in both asphalt slurry seals and coal-tar slurry seals.

*b. Hot-mix bituminous surfaces.* Hot-mix bituminous concrete is composed of well-graded mineral aggregates, mineral filler, and bituminous material (asphalt cement or tar, depending on the desired mixture). Procedures and criteria for hot-mix bituminous mixtures are in MIISTD 620A and TM

5-822-8/AFM 88-6, chapter 9. The hot-mix method of preparing bituminous paving mixtures provides a more thorough uniform coating of the aggregates and allows accurate control of the aggregate sizes. This process results in maximum control of mixture quality. This type of surface may receive traffic as soon as the material has cooled to 140 degrees F. Hot-mix paving mixtures will be compacted while sufficiently hot to be workable, since rolling is ineffective after the material has cooled. A well-designed, hot-mix bituminous concrete is suitable for use under all traffic conditions. Hot-mix bituminous concrete mixing temperatures vary with the viscosity grade; for instance, AC-40 requires higher temperatures than AC-5 because of its higher viscosity. Approximate mixing temperatures would range from 240 to 280 degrees F for mixtures with AC-5 to 280 to 300 degrees F for mixtures with AC-40. The hot mix will be compacted (initial rolling) at temperatures ranging from 240 to 300 degrees F depending primarily on the grade of asphalt used. Well-proportioned and compacted hot-mix surfaces containing properly crushed aggregate have a high stability and high resistance to abrasive action of traffic. When obtainable in small quantities, hot-mix material is ideal for patching and pot-hole repair.

*c. Cold-laid bituminous surfaces.* Cold-laid bituminous pavements are composed of asphalt cement and liquefier (kerosene), liquid asphalt, emulsified asphalt or tar, and a well-graded mineral aggregate. Plant-mix cold-laid bituminous concrete can be produced with little heat. The heat necessary to reduce the aggregate moisture content to 2 percent or less can often be obtained by aeration of the mixture in the air and sun. By varying the amount of liquefier in the asphalt, these mixes can be manufactured to almost any shelf life. They may then be shipped long distances and stockpiled for future use. This material is especially adaptable for maintenance such as patching, and for small jobs where the tonnage does not justify erection of a hot-mix plant. Equipment now commercially available can heat the stockpiled cold mix, a great benefit, allowing its use for patching during cold weather. To get the best results from a cold mix, it should be placed during hot weather and cured to the proper condition for compaction. The equipment can be attached to the tailgate of a dump truck or be self contained on a trailer. Cold mix containing kerosene liquefier is heated in a heat-jacketed pugmill so that it does not come into contact with the flame. The mix can be heated until the volatiles are driven off deleting the need for cure time. Depending on the quality of materials, stability and density can then be achieved as with a hot mix. Suggested gradation

and asphalt types for use in producing plant-mix cold-laid bituminous materials are presented in TM 5-822-8/AFM 88-6, chapter 9 and NAVFAC DM-5.

*d. Sand asphalt and sand tar surfaces.* Sand asphalt and sand tar surfaces are composed of sand and bitumen. (The Air Force does not recommend use of these surfaces at Air Force installations.) Mineral filler is often added to increase the density and stability of the mixture. Asphalt cement, cut-back asphalt, tar, or emulsified asphalt may be used for binder. The mixture may be produced in hot- and cold-mix plants, traveling plants, or with the usually mix-in-place equipment. Sand mix surfaces are fine textured, dense, and relatively impermeable. Their stability and durability depend on the quality and grading of the aggregate, the amount and grade of bituminous binder, and the mixture control during construction. Sand mixes may be used for surfacing roads and streets, and for patching in maintenance work. Sand mixes will not be used in areas subjected to high pressure or hard rubber tires, or truck-type vehicle use.

*e. Sheet asphalt surfaces.* Sheet asphalt is a refined type of hot sand-asphalt pavement in which the grading and quality of sand and mineral filler are carefully controlled. The percentage of asphalt required is, in general, higher than that used for sand asphalt. Sheet asphalt can be used as an intermediate or surface course and is constructed 1 1/2 to 2 inches thick. This surface can be used on roads and parking areas, but it is not recommended for airfields.

*f. Stone-filled sheet asphalt surfaces.* Stone-filled sheet asphalt surfaces are similar to regular sheet asphalt surfaces except for the addition of coarse aggregate passing the 5/8-inch sieve and retained on the No. 8 sieve in varying quantities not exceeding 35 percent. This type of surface is a type of sheet asphalt and gains no stability from a coarse aggregate particle interlock. This surface is used as a surface course constructed 1 1/2 to 2 inches thick and is sometimes called "Topeka Mix."

*g. Bituminous penetration macadam.* A penetration macadam surface is essentially a course of large, uniform graded aggregate that, after compacting and keying, is bound and filled with alternate applications of a heavy bituminous material and smaller aggregate. Thickness of one course varies from 1 1/2 to 2 1/2 inches. These surfaces are stable and withstand considerable tearing action of traffic. This construction is used also as a binder or base course for plant-mix surfacing.

*h. Recycled bituminous surfaces.* Recycling of bituminous pavements is recommended as an alternative whenever it is cost effective. Recycling includes any method of construction that reuses the existing

pavement materials. Of the three general recycling processes, hot, cold, or surface recycling; surface recycling is utilized most often for maintenance and repair.

(1) *Surface recycling.* Surface recycling involves recycling the wearing surface course. Surface recycling includes the milling operation, heater planer, or rejuvenating, cold milling machine or a heater-scarifier. The recycled material is then mixed with water, and lubricating or binding agent, then placed, and compacted. The lubrication agent usually added to the mix is a rejuvenator with additional asphalt sometimes added. The cold milling machine has several advantages over the heater scarifier: less environmentally objectionable, the milled material generally contains a more satisfactory gradation, the milled surface provides a good skid-resistance trafficable surface, and the cold milling will allow deeper repairs when conditions warrant.

(2) *Cold recycling.* Cold recycling includes partial- or full-depth pavement recycling without the use of heat. Cold recycling normally utilizes a cold milling machine, and the recycled mix can be produced either in place or at a central plant. Asphalt emulsion is normally added to the reclaimed material to produce recycled cold mix.

(3) *Hot recycling.* Hot recycling includes any process in which the reclaimed material is heated to be relaid as a hot mix. The old pavement can be broken up and then crushed to the desired gradation, or more commonly, a cold milling machine is used for removal. These reclaimed materials are mixed with new aggregates and asphalts to produce hot recycled mixture.

*i. Porous friction course (PFC).* A porous friction surface course (PFS) is an open-graded, free-draining, bituminous mixture used to reduce hydroplaning and, therefore, improve wet traction. The PFC is a plant-mix hot-laid bituminous surface, usually 1/3 to 1 inch thick. The high void content (20 to 30 percent) of this mix accounts of its internal storage capacity of small amounts for water, internal drainage of this water through the PFC, and more importantly, for the pressure relief afforded. The coarse gradation of a PFC provides both a rough surface texture for tire-pavement contact above the water film level and surface drainage channels. Because of its open texture and inherent low stability, a PFC requires a structurally sound underlying pavement.

### **3-3. Causes of bituminous pavement distress.**

Distress can occur in any type of bituminous surface; however, in the lower quality bituminous surfaces (particularly surface treatments and road-mix

distresses develop more quickly and must be repaired immediately to avoid larger, more costly repairs, or complete failure. Most surface failures result from movement or failure in the base or subgrade material. Although well designed and constructed bituminous surfaces are somewhat flexible and will not rupture under limited deflection, large repetitive deflections will cause the surface to crack or be displaced. Detailed distress identification criteria can be found in TM 5-826-6/AFR 93-5 for airfields and TM 5-623 and MO 102.5 for vehicular pavements. Table 3-1 lists pavement distresses and suggested maintenance and/or repair procedures. Some of the most common causes of failures are listed in the following paragraphs.

*a. Poor drainage.* Bituminous surfaces must be properly drained. Adequate surface and subsurface drainage must be provided. Water ponded on the surface caused by depressions or by high shoulders may eventually seep through the surface and either destroy the bond between pavement courses or saturate the underlying structure, causing a loss of strength. Inadequate subsurface drainage will also lead to base and subgrade saturation, resulting in damage to the bituminous surface. Poor drainage, through ponded water, can decrease the skid resistance of pavement surfaces and decrease the effectiveness of porous friction surfaces. A frequent and thorough inspection should be made of all drains to see that they are free of debris and are working as designed. Subsurface drains should be examined to make sure they are working as intended. In areas subject to long hard freezes, the saturation for base and subgrade resulting from poor drainage along with frost action may completely destroy the pavement. In such cases, the water penetrates and accumulates in the foundation layers. During the winter months, the water begins to freeze, forming ice crystals. As the ice lenses grow, the pavement surface begins to heave and crack. When spring thawing occurs, the pavement structure is left swelled, cracked, weak, and supersaturated. Thus, correction of the drainage problem and rebuilding the pavement structure become necessary.

*b. Weathering.* When bituminous surfaces are placed, the natural elements, air, water, and sun cause weathering or oxidation. Lighter oils are removed, leaving only a hard bitumen residue that is brittle and lacks the binding quality of the original mixture. When severe weathering or oxidation occurs, the surface cracks readily as it flexes under repeated traffic loadings. In addition, weathered surfaces will appear dead or faded during warm weather and are prone to have fine, irregular cracking during cool weather.

Table 3-1. Pavement distress types and maintenance and repair alternatives

	Distress Type	NHR Method					Surface Treatments							Notes		
		Crack Seal	Partial Depth Patch	Full Depth Patch	Skin Patch	Pothole Filling	Apply Heat and Roll Sand	Apply Surface Seal Emulsion	Cold Milling	Apply Rejuvenation	Aggregate Seal Coat	Apply Slurry Seal	Fuel Resistant Seal or Overlay		Porous Friction Surface	
1	Alligator cracking		N,H	M,H						L		L				
2	Bleeding						L,N,H									
3	Block cracking	LM,H									L		L,M	L,M		
4	Bumps and sags		M,H	M,H	M,H			M,H								
5	Corrugation		M,H	M,H												
6	Depression		M,H	M,H	M,H											
7	Edge cracking	I,M	M,H	M,H												If predominant, apply shoulder seal, e.g. aggregate seal coat
8	Joint reflective cracking	L,M,H	H													
9	Lane/shoulder drop off															If predominant, level off shoulder and apply aggregate seal coat
10	Longitudinal transverse cracking	L,M,H	H*					L		L		L,M	L			
11	Patching and utility cut	M	H*	H*												*Replace patch
12	Polished aggregate							M,H				A	A		A	
13	Potholes		L	L,M,H		L,M,H										
14	Railroad crossing			L,M,H												
15	Raveling		H					L,H	M,H	L		M,H	M,H			
16	Rutting		L,M,H	M,H	L,M,H											
17	Shoving		M,H													
18	Slippage cracking	L	M,H													
19	Swell			M,H												
20	Weathering		H					L,N		L		M,H	M,H			
21	Raveling from fuel spills													M,H		
22	Low skid resistance								M,H			L,M,H	L,M,H	M,H		

Note: L - low severity; M - medium severity; H - high severity; A - has only one severity level.

c. *Fuel spills.* Asphalt surfaces are softened by gasoline, jet fuel, hydraulic fluid, or oil drippings. Usually small quantities of gasoline evaporate quickly (unless prevented from doing so by waste or dirt) and cause little damage to a tight AC surface. Jet fuel and hydraulic fluids do not evaporate quickly and may puddle and seep into the asphalt pavement. Loads applied while the asphalt is softened cause failures in the pavement surface. Continuous drippings of oil may also soften the asphalt enough to cause shoving under traffic. Spillage and drippings can be a severe problem on a porous friction course due to the high void content. This enables the fuel to readily penetrate and disintegrate the surface. In areas where it is anticipated that the pavement will be subjected to fuel and oil spillage, coal-tar or another approved fuel-resistant surface material will be used.

d. *Poor maintenance.* Poor maintenance procedures result in rapid deterioration in areas where deficiencies occur. Timely and proper maintenance can prevent many distresses from occurring. Table 3-1 gives the possible distresses and the suggested maintenance and repair procedures to follow.

e. *Construction deficiencies.* Many causes of bituminous surface distresses are related to pavement construction deficiencies and may not appear for some time after the pavement has been constructed. These problems require increased maintenance resulting in higher costs. The most common construction errors are discussed in the following paragraphs.

(1) *Unseasonable operations.* Best results are obtained when bituminous paving or surfacing operations are done during dry and warm weather. Work performed during cold and damp weather is rarely satisfactory. Low temperature chills the bitumen before proper bedding of the aggregate, or compaction of mixture is obtained. Cool, cloudy, damp weather slows the evaporation of the volatile oils in cutback materials and may cause stripping of the aggregate. Applications of a hot course of bituminous material on a cold or damp surface may result in poor bond and low density.

(2) *Inappropriate bituminous materials.* The type of bituminous material to be used is dependent on the type and gradation of aggregate, the climate conditions, the type of volume of traffic, and the type of equipment used for mixing and application. A bituminous material should be selected that is sufficiently flexible during the winter months and stable during the summer months. Guidance for selection is provided in TM 5-822-8/AFM 88-6, chapter 9; and NAVFAC DM-5.

(3) *Aggregate deficiencies.* Poor gradations of aggregate produce unsatisfactory surfaces. Excess

fine particles tend to form an unstable mix which is difficult to compact. Excess coarse particles in plant- or road-mixed material produce an open, porous surface which permits moisture to enter and damage pavement. Excessive use of uncrushed materials, especially natural sands, often results in unstable pavements with poor durability. Unsound aggregate wears rapidly or is shattered or displaced under traffic; rapid destruction of surface follows. Aggregates for seal coats and surface treatments which contain excess fine particles (over 5 percent passing the 100 mesh sieve) do not adhere to bituminous material and tend to ravel. Surface treatment aggregates should generally be a one-sized gradation with the larger particles being not more than approximately twice the size of the smaller particles.

(4) *Overheating.* Overheating bitumen reduces or destroys its cementing qualities reducing its ability to bond to aggregate. In hot plant mixes, bitumen may be burned either by direct heat or by overheated aggregate. Overheating the asphalt binder also reduces its flexibility resulting in increased cracking as the mixture ages. Overheating cutback (e.g., fluxed bituminous materials) drives off the lighter oils, leaving a heavier material that cures more rapidly and is difficult to mix.

(5) *Improper mixing.* Mixing must be continued until all particles of the aggregate are completely coated. Mixing equipment must be cleaned during and after operations. Otherwise, lumps of cooled, bituminous mixture can be dropped into succeeding batches or on section of pavements. If proper mixing is not accomplished, the resulting surfaces may be uneven, have fat spots, or suffer raveling.

(6) *Poor proportioning.* Too much or too little bitumen in proportion to aggregate causes fat or lean spots, respectively. The range of bitumen content between the minimum and maximum required is relatively small for dense-graded materials.

(7) *Placement errors.* One common error in placing a surface course is improper preparation of the surface on which it is to be placed. Irregularities should be adjusted and the surface cleaned and primed or tacked before the new material is placed. Neglecting any of these necessary preliminary operations creates an improperly prepared base which cannot be corrected by simply covering with a surface course. Prime material should be allowed to cure before placement of paving mixture. Too much tack or prime can cause a rich pavement and result in shoving and slippage. Improper pressure, clogged nozzles, poor nozzle alignment, or uneven overlapping of sprays result in longitudinal streaks in surface treatments or seal coats. Each time a pressure

Table 3-2. Possible causes and types of imperfections in finished pavements

Insufficient or Non-Uniform Tack Coat	Improperly Cured Prime or Tack Coat	Mixture Too Coarse	Excess Fines in Mixture	Insufficient Asphalt	Excess Asphalt	Improperly Proportioned Mixture	Unsatisfactory Batches in Load	Excess Moisture in Mixture	Mixture Too Hot or Burned	Mixture Too Cold	Poor Spreader Operation	Spreader in Poor Condition	Inadequate Rolling	Over-Rolling	Rolling Mixture When Too Hot	Rolling Mixture When Too Cold	Roller Standing on Hot Pavement	Overweight Rollers	Excessive Moisture in Subsoil	Excessive Prime Coat or Tack Coat	Excessive Hand Raking	Labor Careless of Unskilled	Excessive Segregation in Laying	Operating Finishing Machine Too Fast	<p align="center"><b>Types of Pavement Imperfections That May Be Encountered In Laying Plant-Mix Paving Mixtures</b></p>		
				X	X	X													X							<b>Bleeding</b>	
				X				X	X																		<b>Brown, Dead Appearance</b>
					X	X	X													X			X				<b>Rich or Fat Spots</b>
		X	X			X	X			X	X	X	X	X	X	X					X	X	X	X			<b>Poor Surface Texture</b>
X	X	X				X	X			X	X	X	X		X	X	X	X			X	X	X	X			<b>Rough Uneven Surface</b>
		X		X		X	X			X	X	X	X		X	X					X	X	X				<b>Honeycomb or Raveling</b>
		X								X	X	X	X		X	X					X	X	X				<b>Uneven Joints</b>
			X		X	X				X			X		X	X	X	X				X					<b>Roller Marks</b>
X	X		X		X	X	X	X			X	X			X			X			X						<b>Pushing or Waves</b>
			X	X		X								X	X		X	X									<b>Cracking (Many Fine Cracks)</b>
														X				X	X								<b>Cracking (Large Long Cracks)</b>
		X				X				X	X	X		X	X			X									<b>Rocks Broken by Roller</b>
		X		X		X			X	X	X	X											X	X			<b>Tearing of Surface During Laying</b>
X	X		X		X	X		X		X			X	X		X		X	X	X						<b>Surface Slipping on Base</b>	

(Courtesy of the Asphalt Institute)

distributor stops, it drips some bituminous material, even when equipped with circulating spray bars. If this bitumen is allowed to accumulate on the pavement surfaces, fat spots or traverse streaks will result. Streaking will produce rough unsightly surfaces that are subject to extensive raveling and pot-hole disintegration. Table 3-2 gives a listing of possible causes and types of imperfections in finished bituminous pavements.

(8) *Laydown.* In spreading plant-mixed materials, it is important to keep the material level in the spreader hopper. Otherwise, segregation of the material will occur. Large aggregates tend to roller flow to either edge of the hopper. This can result in segregation with excess large aggregates at the edges and an excess of fines in the center portion. This segregation will lead to low or non-uniform density throughout the layer. Joints between low density areas of adjoining lanes of plant-mix materials frequently result in longitudinal cracks or dips at the joints. Unless joints are staggered in two-course construction, this fault is magnified. The mixture requires rolling with the proper equipment at the correct stage of cooling or curing to obtain the maximum practical density. Rolling the mix when it has become too stiff results in low density and a correspondingly higher air void content which leaves the pavement susceptible to rapid weathering. An insufficient amount of rolling can have the same effect. Cracking and aggregate raveling caused by increased oxidation will also develop in a low density pavement. Low density pavements can benefit from additional rolling with pneumatic-tired rollers providing the pavement temperatures are high and the tires are inflated to their maximum pressure (minimum of 90 psi). Periodic rolling with

pneumatic tires is also often beneficial to any low traffic areas such as runway and taxi-way shoulders and open-storage surfaces.

**3-4. Types of bituminous pavement distress**

The types of pavement distress detailed in the following paragraphs include cracking and other distresses caused by traffic, climate, and other reasons.

a. *Alligator cracks.* Alligator cracks are interconnected cracks forming a series of small blocks resembling an alligator skin. The length of the cracked pieces are usually less than 6 inches on the longest side (fig. 3-1). In some cases, alligator cracking is caused by excessive deflection of the surface over unstable subgrade or lower courses of the structure. The unstable support is usually the result of saturation of the bases or subgrade. Although the affected areas in most cases are not large, occurring principally in traffic lanes, occasionally, will cover entire sections of pavements.

b. *Bleeding.* Bleeding or flushing is the upward movement of the binder material in the pavement creating a film of bituminous material on the surface (fig. 3-2). This condition usually occurs during hot weather and will cause an extremely slippery surface. The most common cause of bleeding is too much asphalt binder in one or more of the pavement courses. This can result from a rich mix, variations in aggregate blending, improperly constructed seal coat, or heavy prime or tack coat. Traffic volume, tire pressure, or load in excess of design quantities can cause over compaction of bituminous layers forcing the binder to the surface. Bleeding caused by trafficking is not normally a problem on airfield pavements due to lower traffic volumes and less channelized traffic. Variations in asphalt content in



Figure 3-1. Alligator cracks.



Figure 3-2. Bleeding.



Figure 3-3. Block cracking.

PFC are not normally critical for airfield pavements for this reason.

*c. Block cracking.* Block cracking is an interconnected series of cracks that divide the pavement into approximately rectangular pieces. Block cracking is differentiated from alligator cracking by size and by not being load related. The blocks usually range from 1 by 1 foot to 10 by 10 feet (fig. 3-3). The cracking is caused mainly by daily temperature cycling and by shrinkage of the asphalt concrete. This distress is not load related but is usually associated with the asphalt aging and hardening. This usually

occurs over an entire pavement of the same history, cross section, and traffic.

*d. Bumps and sags.* Bumps and sags, respectively, are small, localized, upward and downward displacements of the pavement surface (fig. 3-4). Bumps can be caused by differential heave or settlement over utilities, frost heave, the buildup of material in a crack in combination with loading. Bumps can also be caused by the movement of PCC slabs overlaid with AC where the movement is reflected through the asphalt pavement. Sags are caused by a localized failure of the underlying material resulting in subsidence.





Figure 3-4. Sag in asphalt pavement.

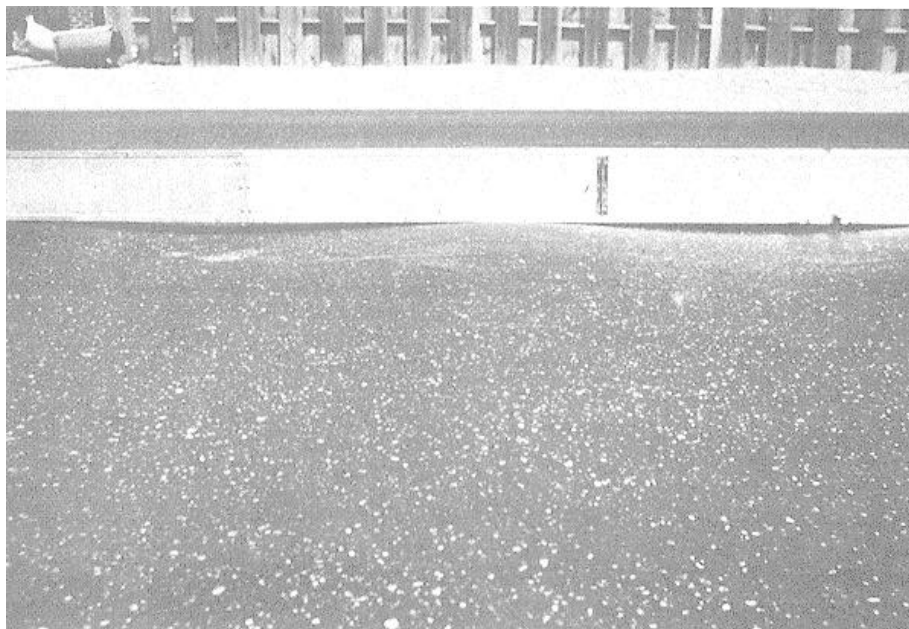


Figure 3-5. Corrugation.

e. *Corrugation.* Corrugation, sometimes called washboarding, is a form of plastic surface movement typified by ripples across the bituminous pavement surface (fig. 3-5). The cause of corrugations is usually lack of stability in the bituminous mix. Lack of stability can be caused by the mix being rich, the aggregate having excessive amounts of fines, rounded or smooth textured particles, poor bond between material layers, or the use of soft binder.

f. *Depressions.* Depressions are localized low areas of limited size which may or may not be accompanied by cracking (fig. 3-6). Depressions dip below grade and water collects in them. These "birdbaths" are not only a source of pavement deterioration, but also are a traffic hazard, especially in freezing weather. Depressions may be caused by traffic heavier than that for which the pavement was designed, by settlement of the underlying pavement layers, or by poor construction methods.

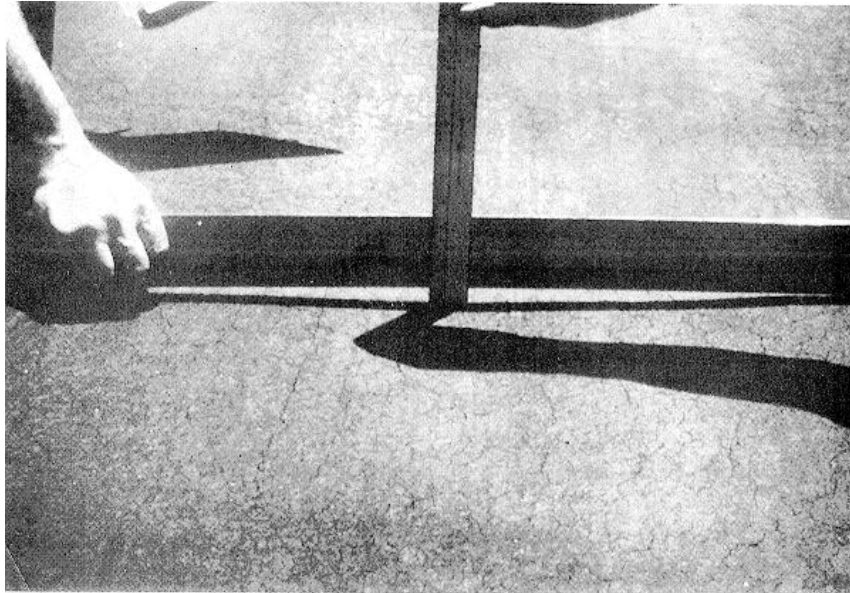


Figure 3-6. Depression.



Figure 3-7. Edge cracking.

*g. Edge cracking.* Edge cracks are parallel to and usually within 1 to 2 feet of the edge of the pavement (fig. 3-7). This distress is accelerated by traffic loading and is caused by a weakened base or subbase at the pavement edge. Weakening of the base or subbase can normally be associated with a drainage problem causing water intrusion.

*h. Joint reflective cracking (from longitudinal and transverse joints) in PCC slabs.* Joint reflective cracking distress occurs only on asphalt pavements

overlying PCC pavements (fig. 3-8). These cracks are caused by the moisture- or thermal-induced movement of these slabs under the asphalt pavement. This distress is not load related, although traffic will damage the asphalt pavement at the cracks.

*i. Lane/shoulder dropoff.* Lane/shoulder dropoff is a difference in elevation between the pavement edge and the shoulder (fig. 3-9). This distress is caused by either shoulder erosion or settlement, or



Figure 3-8. Transverse reflective crack.



Figure 3-9. Lane/shoulder dropoff.

by building up the roadway (i.e., overlay) without correcting the shoulder height.

*j. Longitudinal/transverse cracking (non-PCC slab joint reflective).* Longitudinal cracks are those which run parallel to the pavement while transverse cracks extend perpendicularly across the pavement (fig. 3-10). This cracking may be caused by poorly constructed paving joints, temperature effects (shrinkage or expansion), hardened or oxidized asphalt, or cracks reflecting up from cracked

underlying asphalt layers or stabilized base material.

*k. Patching and utility cut.* Patching and utility cut patching are areas where the original pavement was removed and replaced with new material (fig. 3-11). These areas are considered defects because the patched area or adjacent area usually does not perform as well as the original pavement.

*l. Polished aggregate.* Polished aggregate is a term applied to asphalt pavements in which the



Figure 3-10. Transverse crack.

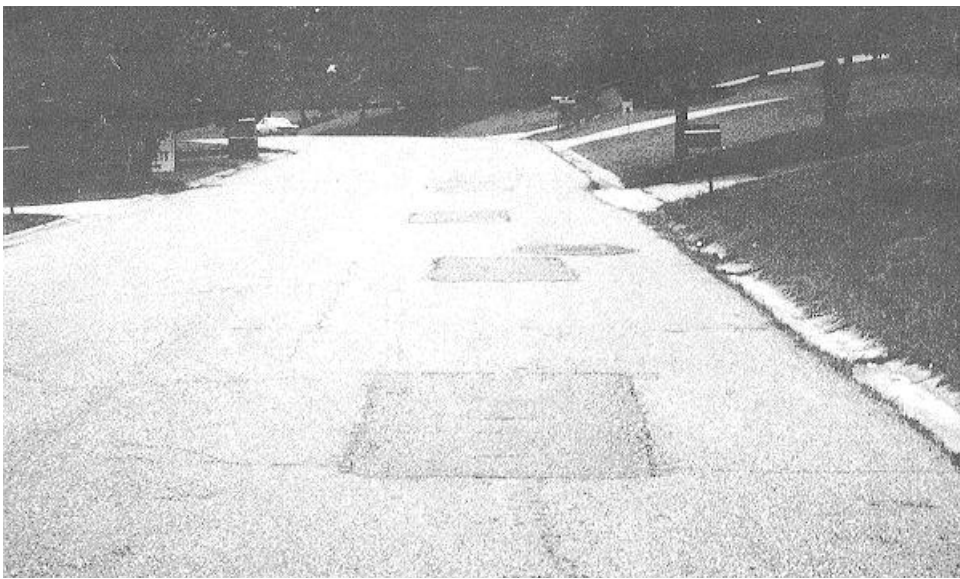


Figure 3-11. Utility cut patching.

surface aggregate has been worn smooth. Polished aggregate causes a reduction in skid resistance, especially when wet (fig. 3-12). This distress is caused by low quality aggregate and repeated traffic applications.

*m. Potholes.* Potholes are usually caused by a localized weakness in the pavement resulting from a combination of such factors as too little asphalt, thin surface thickness, too many fines, too few fines, or poor drainage (fig. 3-13). Unless repaired

promptly, their growth will be accelerated by traffic and moisture collected in the pothole.

*n. Railroad crossing.* Railroad crossing distresses are depressions or bumps around and/or between the tracks (fig. 3-14).

*o. Raveling.* Raveling is a progressive separation of the aggregate from the binder (fig. 3-15). Raveling is the failure of bond between the aggregate and the bituminous binder. Raveling may be caused by insufficient compaction during construction, construction



Figure 3-12. Polished aggregate.



Figure 3-13. Potholes.

during wet or cold weather, dirty or disintegrating aggregate, insufficient binder in mix, or over-heating of the surface mix.

*p. Rutting.* Rutting is a depression in the wheel path (fig. 3-16). In extreme cases there may be uplift between the wheel paths in conjunction with the rutting. Rutting may be caused by a permanent deformation in the pavement layer or the subgrade due to traffic loads. Pavements constructed of low stability AC or unsatisfactory compacted AC are

leading causes for the deformation in the pavement layers.

*q. Shoving.* Shoving is a localized plastic movement in the bituminous surface (fig. 3-17). Areas subjected to frequent vehicular braking action can exhibit shoving. The cause of shoving is usually lack of stability in the bituminous mix. Lack of stability can be caused by the mix being too rich, the aggregate having excessive amounts of fines or rounded or smooth textured particles, poor bond between



Figure 3-14. Railroad crossing.



Figure 3-15. Raveling.

material layers, or the use of a soft binder. Plastic flow in patching materials can also be caused by excessive moisture in the mix, contamination by oil spillage, or too much volatile material remaining when a cold-laid patch is placed.

*r. Slippage cracking.* Slippage cracks are usually crescent shaped cracks that normally point in the direction of the thrust of the wheels during braking (fig. 3-18). This distress is caused by a low strength surface mix or a lack of bond between the surface

layer and the course beneath. This slippage or delamination can cause failures in PFC under traffic. The slippage can be caused by poor drainage which could aggravate a stripping problem or by construction deficiencies as outlined previously.

*s. Swell.* Swell is the localized upward displacement of a pavement due to the upheaval of the subgrade or some portion of the pavement structure (fig. 3-19). Swell or frost heave is commonly caused by expansion of freezing water in the lower courses



Figure 3-16. Rutting.



Figure 3-17. Showing

of the pavement structure or subgrade. It may also be caused by infiltration of moisture into an expansive-type soil.

*t. Weathering.* Weathering is a process in which the more volatile parts of the asphalt are lost which results in the hardening or aging of the asphalt binder in a pavement (fig 3-20). Defects such as cracks or holes in the pavement or low pavement density will allow more area of the pavement to be exposed to air and water and increase the weather-

ing process. Raveling is often associated with weathering and is often a direct result of it. Weathering can be a problem in open-graded mixtures such as PFCs due to the increased surface area exposed to weathering conditions.

*u. Raveling from fuel spills.* Raveling from fuel spills is similar to the raveling described earlier (fig 3-21). However, in this case the raveling is caused by fuel leaching away the asphalt binder. This distress will accelerate if more fuel is spilled on a

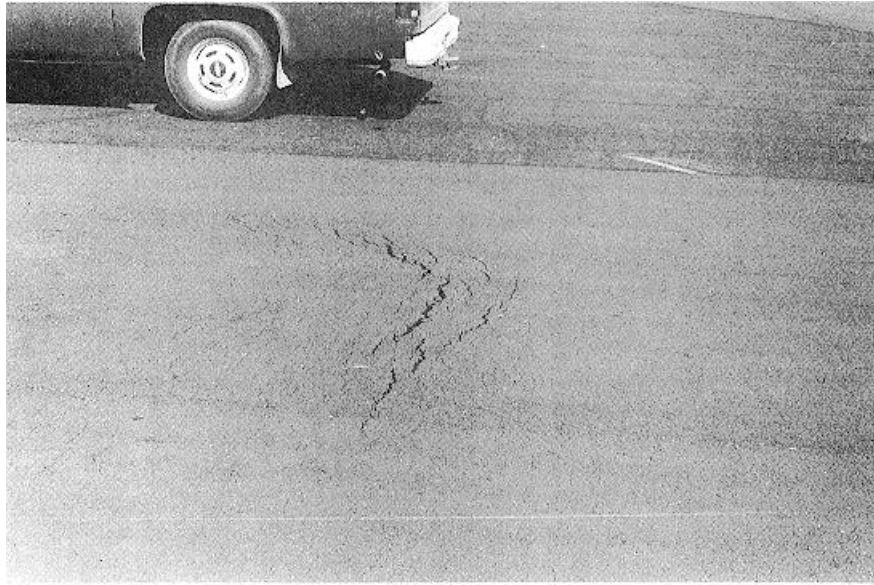


Figure 3-18. Slippage cracks.



Figure 3-19. Swelling.

surface which had previously started raveling. Fuel spills on PFCs cause distress due to the void space provided in the pavement surface.

v. *Low skid resistance.* Low skid resistance can be caused by a variety of factors including excessive asphalt binder and the type of aggregate used in the mixtures. The options available to alleviate this distress are to overlay or recycle the pavement, groove the pavement, or apply a surface treatment. When the pavement is structurally sound, the first alter

native is unnecessary and the grooving of asphalt pavements may be the best solution (fig 3-22). Surface treatments include seal coats, slurry seals, and PFC.

### 3-5. Bituminous pavement materials

Materials for maintenance and repair of bituminous surfaces should be equal to or exceed the quality of materials used in initial construction.



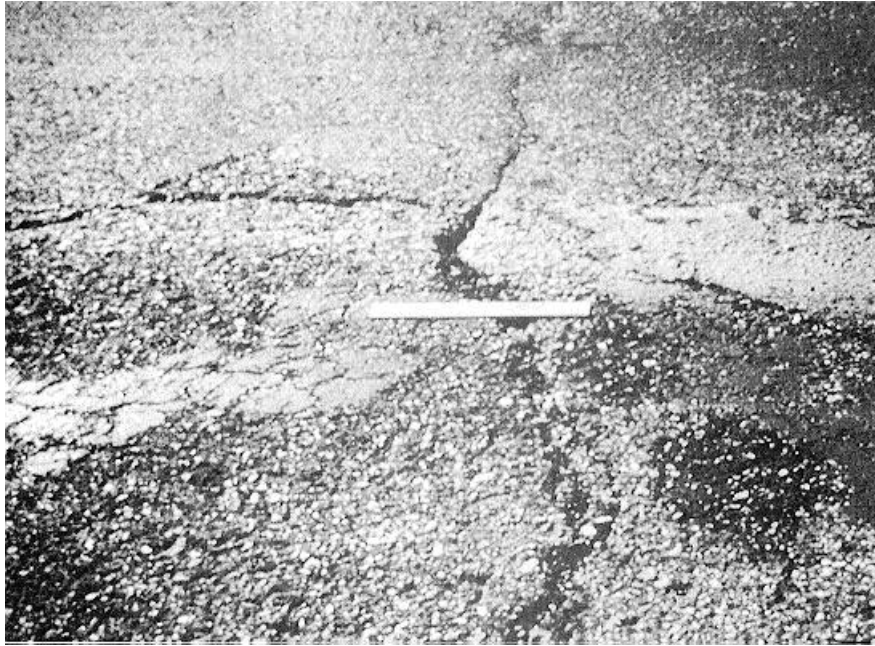


Figure 3-20. Weathering.

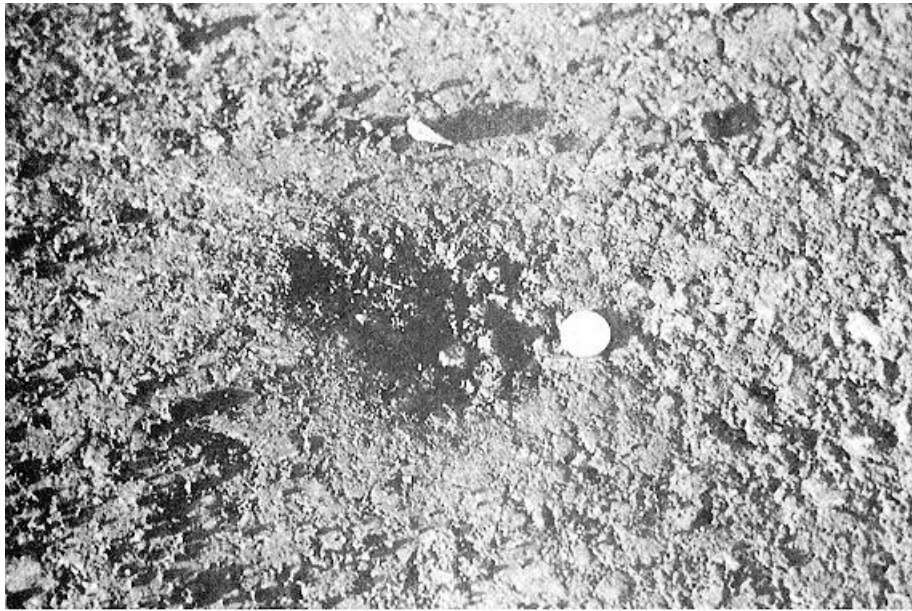


Figure 3-21. Rave

a. *Aggregates.* A comprehensive survey of the availability of needed aggregate should be conducted, thereby determining local and commercial sources and supplies. Local materials usually require some processing such as crushing, screening, or blending. These will include sand, gravel, and rock that may or may not require any preparation other than screening as well as materials that require both crushing and screening such as limestone and granite. In the vicinity of steel mills, g from fuel spills.

suitable slag aggregate is usually available however, the slag must be seasoned before being used in pavements. Other specialized aggregate types limited to certain localities are often available for use. In some localities, subgrades composed of sand are mixed with bituminous material without adding other aggregates. Aggregate requirements should fit the type of surface involved. For high-quality surfaces, suitable aggregate qualities must be specified. For low-cost road-mix surfaces, ag



Figure 3-22. Grooved asphalt concrete pavement.

gregate requirements may be less rigid to minimize costs. Guidance on aggregates is provided in TM 5-822-8/AFM 88-6, chapter 9 and NAVFAC DM-5.

*b. Quality.* Aggregates must carry the load imposed by traffic and provide the necessary resistance to wear. Aggregates should be hard, tough, durable, and free from an excess of flat, elongated pieces. Aggregates for a PFC must be of high quality with an allowable Los Angeles abrasion loss of 25 percent for airfield pavements and 40 percent for other pavements. Generally, for plant mixes, surface treatments, and seal coats, the aggregates will be clean. In some types of road-mix operations, the use of locally available aggregate such as pit-run gravel containing limited quantities of clay and silt has given good results when combined with the recommended grade of bituminous material. In no case will the aggregate particles be coated with films that prevent the bitumen from coating and sticking since this will reduce the durability of the asphalt mixture.

*c. Gradation.* Different types of bituminous surfaces require different aggregate gradations. The classifications generally used are dense-graded, open-graded, and uniform-graded aggregate.

(1) *Dense-graded.* The dense-graded group is made up of aggregate, well graded from coarse to fine, which contains an appreciable amount of material passing the No. 200 sieve (dust). The maximum size aggregate normally allowed for AC mixtures is 1 inch (3/4 inch preferred), with the fine aggregate having 3 to 6 percent passing the No. 200 sieve. For a given density, the amount of mineral

filler required increases as the size of the coarse aggregate decreases. Graded sands, pit-run sands and gravels, and crusher-run materials are normally required in the higher types of bituminous surfaces because they withstand abrasion well and are water resistant.

(2) *Open-graded.* The open-graded group is made up of poorly graded aggregates and may differ from the densely graded group only in the fines it contains. Open-graded materials have a deficiency of some aggregate sizes between coarse and mineral filler. Densities and voids are almost entirely controlled by the proper amount of fines in the mix design. Open-graded aggregates used in surface courses require a seal coat to provide necessary resistance to moisture and weathering unless designed for a specific purpose (PFCs).

(3) *Uniform-graded.* Uniform-graded aggregate is made up of aggregates of essentially one size. Uniform-graded aggregates are primarily used for surface treatments and macadam courses.

*d. Size limitations.* Aggregate size is usually controlled by the thickness of the course in which it is to be used. For plant-and road-mix types, generally the maximum size is one-half the thickness of the course. In surface treatments, usually aggregate seals and slurry seals, the maximum size aggregate is the thickness of the finished course; for penetration macadam, the maximum size may be two-thirds of the course.

*e. Gradation specifications.* For specifications covering the aggregate quality and gradation for various types of mixes, see TM 5-822-8/AFM 88-6, chapter 9 of NAVFAC DM-5. State specifications

concerning aggregate quality and gradation may also be used in selecting aggregates for bituminous surfaces to be placed on roads and streets.

*f. Stockpiling.* After determining the source of supply, as mentioned earlier, thought should be given to stockpiling the most frequently used aggregate. These stockpiles should be located convenient to work areas and, if possible, be on a clean, hard surface to avoid contamination and make loading easy. On large installations that cover many square miles and have hundreds of miles of roads, streets, and runways, it may be time-saving and economical to have multiple stockpiles located in strategic areas.

*g. Handling aggregates.* In handling aggregates, the source of supply and method of shipping will determine some of the equipment necessary to economically and adequately move the material from car to stockpile to job. Aggregates may be shipped by rail in ordinary coal cars or in hopper-type coal cars, barges, or trucks. For rail delivery a dragline equipped with clamshell has been used in unloading ordinary coal cars. The hopper-type cars may be unloaded using a portable material conveyer, or by using a front-end loader, with a minimum of preparation at the car dumping site. Specially equipped loaders are currently available that are capable of moving on their own along the top of any type of car for unloading. A clamshell or another type of shovel will be required to unload barges. A medium-sized four-wheel-drive-front-end loader is ideal for keeping stockpiles shaped up, and for loading trucks. Depending on the size of the operation, one or more dump trucks will be available for unloading and hauling materials to the job site. An adequate number of square end shovels and other hand tools should be available for cleanup and for mixing material in small quantities.

*h. Asphalt.* Asphalt is a dark brown cementitious material, that is solid, semisolid, or liquid in consistency, of which the predominating constituents are bitumens that occur in nature as such as are obtained as residue in refining petroleum.

*i. Asphalt cement.* Asphalt cement, the basic material of the asphalt family, is refined from crude oil at temperatures below 100 degrees F and is solid or semisolid. To be useful in paving or maintenance operations, it must be fluid enough to coat aggregate. This can be accomplished by heating in a storage tank, asphalt kettle, or pressure distributor, by dissolving in a petroleum solvent (liquid asphalts), and by combining water and an emulsifying agent (emulsion). Asphalt cements have been classified in a number of grades using either the penetration or the viscosity classification. The paving grades of asphalt cements range from a rock-hard

(may be powdered) material to a soft flux. The penetration grade asphalts (five grades ranging from 40 to 300) are classified by a standard penetration test. Penetration is determined by measuring the distance a standard needle penetrates the surface of the asphalt sample under specified conditions of time, temperature, and load. Recently, asphalts have been classified by determining the viscosity of the original asphalt and the viscosity of the asphalt after it has been aged in a thin film oven test. Determining viscosity of the original asphalt results in grade classifications ranging from AC 2.5 to AC 40. Determining viscosity of the "aged residue" has resulted in grade classifications ranging from AR 10 to AR 160. Table 3-3 roughly compares the three classifications. The grades listed in the tabulation above will generally cover any combination of climate, traffic, and construction considerations. The temperatures for use of residue graded paving asphalts vary slightly from those recommended for the penetration grade asphalts. See TM 5-822-8/AFM 88-6, chapter 9 or NAVFAC DM-5 for the suggested temperatures. Table 3-4 indicates suggested spraying and mixing temperatures for AR grades. Pugmill mixing temperatures for opengraded mixes will be between 225 and 250 degrees F. To obtain best results, bituminous materials are applied at the temperature ranges prescribed for the various grades. Some grades require no heating when used during hot summer temperatures. Prolonged heating above the temperatures recommended causes loss of volatile materials resulting in increased viscosity. Extreme overheating burns the bituminous material and reduces the binding qualities. Overheating liquid asphalt materials is dangerous because of the highly flammable nature of the distillates. Recommended temperature limits are shown in TM 5-822-8/AFM 88-6, chapter 9 or NAVFAC DM-5. To obtain the best results from maintenance and repair operations, the proper grade of bituminous material must be selected. This selection is affected by such factors as type and gradation of aggregate, weather, and objective and nature of the repairs to be made. In cases where more than one type of bituminous material will give satisfactory results, selection may depend upon the availability and handling experience with the material. In general, light grades are preferable in cold climates and heavy grades in warm climates. Light grades are also appropriate for pavement subject to light traffic. The use of latex rubber modified asphalt binders has been used to improve the performance of PFCs where a tenacious binder is important. Silicon has also been used on the order of 1 ounce per 5,000 gallons of asphalt binder to improve mixing and handling qualities of PFCs.

Table 3-3. Grade classification

Penetration grades	Viscosity grades	
	AC (original asphalt)	AR (aged residue)
200-300	2.5	10
120-150	5	20
85-100	10	40
60-70	20	80
40-50	40	160

Table 3-4. Mixing temperatures

Grade of paving asphalt	Distributor spraying temperature, °F		Pugmill mixing temperature of aggregates, °F	
	Min	Max	Min	Max
AR-160	*	*	300	350
AR-80	295	350	275	325
AR-40	290	350	275	325
AR-20	285	350	275	325
AR-10	275	325	225	275

\*Seldom used for spraying.

j. *Liquid asphalts.* Asphalt cements which have been softened or liquified by blending with petroleum solvents are generally referred to as liquid or cutback asphalts. When the liquid asphalt is spread on the road or mixed with aggregate, the solvents evaporate leaving the asphalt cement. Liquid asphalts are designated rapid curing (RC) containing a naphthaor gasoline-type solvent. Medium curing (MC) contains a solvent similar to kerosene, and slow curing (SC) contains solvent similar to heavy fuel oil which may be added to an asphalt cement but is often left in during the refining process. The RC, MC, and SC grades are designated as 70, 250, 800, and 3,000 which is based on viscosity rating. A special MC-30 grade, used almost entirely for prime coating and as a dust palliative, is included in the MC group. The grades are designated by the low side of the viscosity range for each grade with the upper viscosity limit being twice the lower value. For example, an RN-70 has a viscosity range of 70-140 centistokes. Each group, RC, MC, and SC, contains the same viscosity grades except for the additional MC-30 grade. In areas with air pollution regulations RC and MC grades may not be available.

k. *Emulsified asphalt.* Emulsified asphalts are liquid mixtures that contain asphalt cement, water, and an emulsifying agent, which permits the asphalt to remain in dispersion in the water. There are several emulsifiers available including soap, clay, and various salts. Each must be appraised for compatibility, with the asphalt cement being used. Varying the amount and kind of the emulsified agent controls the breaking time or reversion time of the emulsified asphalt to asphalt cement. Emul-

sified asphalts are graded according to the time required to break or separate from suspension and are categorized as rapid setting, medium setting, and slow setting. Emulsified asphalts are also classified as anionic or cationic. The designations for anionic emulsions are SS, MS, and RS, and the designations for cationic emulsions are CSS, CMS, and CRS. In the anionic type, the globules of asphalt have a negative electrical charge. In the cationic type, the globules are positively charged. These differences in electrical charge improve the coating and bonding properties when used with aggregates of opposite electrical charged surfaces. The choice of a cationic or anionic type is usually based on experience with a particular aggregate. Laboratory testing may be required when utilizing a new source of aggregate. Emulsions are particularly adapted for use during poor weather conditions with damp aggregates when the use of other bituminous materials is prohibited. When temperatures are low, emulsions must be protected to prevent freezing. Freezing causes separation of the water and asphalt rendering the emulsion useless. The letter h in grade SS-1h indicates the base asphalt is somewhat a harder material.

l. *Powdered asphalt.* Powdered asphalt is a pulverized hard asphalt residue which has a penetration of 0 to 5. It is usually shipped in 100-pound bags. It may be combined with a flux or other liquid asphalt product to form an asphalt cement. The ability to handle these materials without heating is often advantageous. Mixed-in-place mixtures with a considerable amount of fine aggregate generally use a low percentage of liquid asphalt for mixing and coating the aggregate. Powdered asphalt can then be incorporated into the mix to produce an asphalt cement of a consistency that could not have been used in the original mixing operation.

m. *Hot mix.* Hot mix should be used for all applicable maintenance and repair work whenever possible. The use of hot mix from local plants will increase the strength and durability of repairs over those constructed with cold mix.

n. *Cold mix.* Cold mix is used extensively for repairs because it can be stored for long periods of time without damage. This mix can be bought and stored in bulk on the base or may be obtained locally in some areas by the truck load. There are commercially available cold mixes that are shipped in bags or barrels and can be used directly. These products make the material easier to handle than bulk materials.

o. *Crack sealers.* Crack sealers are used to seal cracks to prevent water from entering the pavement structure. Narrow cracks are normally sealed with

a liquid asphalt while larger cracks are often filled with a sand asphalt mixture.

*p. Rejuvenators.* Rejuvenators are sprayed onto an asphalt surface and allowed to penetrate into the surface asphalt and soften or rejuvenate it. These materials will normally penetrate from 1/4 to 3/8 inches into the pavement. These products should only be applied to structurally adequate pavements with relatively high air void content. The use of rejuvenators on high speed pavements is not recommended because it may lower the skid resistance to an unsafe level.

*q. Tars.* Road tars are produced by the destructive distillation of coal. Road tars are designated RT 1 to RT 12, inclusive, ranging from the low viscosity grade to the high viscosity grade. In addition, there are four other grades of tar designated RTCB-5, RTCB-6, RT-12 Modified, and RT-14. RTCB-5 and RTCB-6 are cutback tars. RT-12 Modified was developed to be used in tar rubber pavements. RT-14 was developed to be used in place of rubberized tar due to the restrictions imposed by Occupational Safety and Health Administration (OSHA) on the production of rubberized tar blends.

*r. Storage of materials.* All materials, whenever possible, should be stored so as to minimize the effects of climatic condition. Material manufacturers can supply the individual requirements of their particular products.

(1) *Storage of bituminous materials.* The type and quantity of material stored depend upon local conditions. Small quantities are usually stored in drums. Larger quantities, for example over 5,000 gallons of one grade, will be stored in tanks equipped with heater coils. Normally, bituminous storage tanks will be equipped with hot oil or steam coils, unless booster-type unloading equipment is available. Storage tanks will have a circulating system to ensure material uniformity. In cold climates, insulation of permanently installed storage tanks is usually economical. Elevation of tanks to permit gravity loading of distributors is desirable. Storage of large quantities of liquid bituminous materials in drums is not recommended because of the tendency for heavy and light portions of emulsions and liquid asphalts to separate. Drums of liquid bituminous materials will be turned or rolled 180 degrees once a month, or more often, to counteract tendency to separate. Types of stored bituminous material will usually include at least one light grade material suitable for prime coating and a heavier grade suitable for patching or cold mixing. Light and heavy grades of the same material may be mixed in varying proportions to obtain intermediate grades. Heavy liquid materials can also be further diluted by addition of solvent similar to that originally

used. Naphtha or gasoline is used for RCs and kerosene for MCs. Emulsions can be thinned by adding water. Material must be warm (minimum application temperature) and stirred continually during mixing or diluting. In cold weather, it is necessary to heat drums to transfer materials into kettles or distributors. One drum at a time may be heated by suspending over the bituminous kettle while material in the kettle is heated. Drums may also be moved into a warm building prior to use or they may be heated in specially prepared structures. Liquid asphalt materials must not be placed near open fires. Buildings where they are heated will be ventilated near the ceiling or roof because gases released during heating are highly inflammable. Tars will not mix with asphalt in drums or containers. Containers must be thoroughly cleaned before changing from tar to asphalt or vice versa.

(2) *Storage of patching mixtures.* In areas near cities, there is usually a commercial plant that produces hot-and cold-mix paving materials. Small quantities of hot-and cold-mix bituminous materials may be obtained from these plants at any time. Where these facilities are not available, some form of local cold mixing is necessary. Good cold mixes can be produced with minimum equipment if care is exercised in selecting, processing, and storing materials for the finished product. Many of these coldmix types can be mixed in warm weather, stockpiled, and used several months later.

### 3-6. Bituminous pavement equipment

There are many different types and models of equipment that can be used for pavement maintenance and repair. The equipment types mentioned below are for general maintenance and repair usually performed on all installations.

*a. Cleaning equipment.* Motorized vacuum brooms (fig 3-23), circular brooms (fig 3-24), drag brooms, routers, wire brushes, and compressed air are used for cleaning the pavement surface and removing excess aggregate. Cleaning operations are necessary in preparation for seal coating, crack filling, skin patching, and application of slurry seals.

*b. Hand tools.* Chisels, sledgehammers, shovels, pry bars, and picks are examples of hand tools. Hand tools may be used to make straight, vertical cuts through pavements as well as to break up deteriorated pavement. The use of hand tools is not recommended where other equipment is available because hand operations are time-consuming.

*c. Pouring pots.* Pouring pots are used to pour hot sealing material into previously prepared cracks or joints. The pots hold up to 5 gallons of liquid and dispense the material either from top or bottom spouts.



Figure 3-23. Motorized vacuum broom.

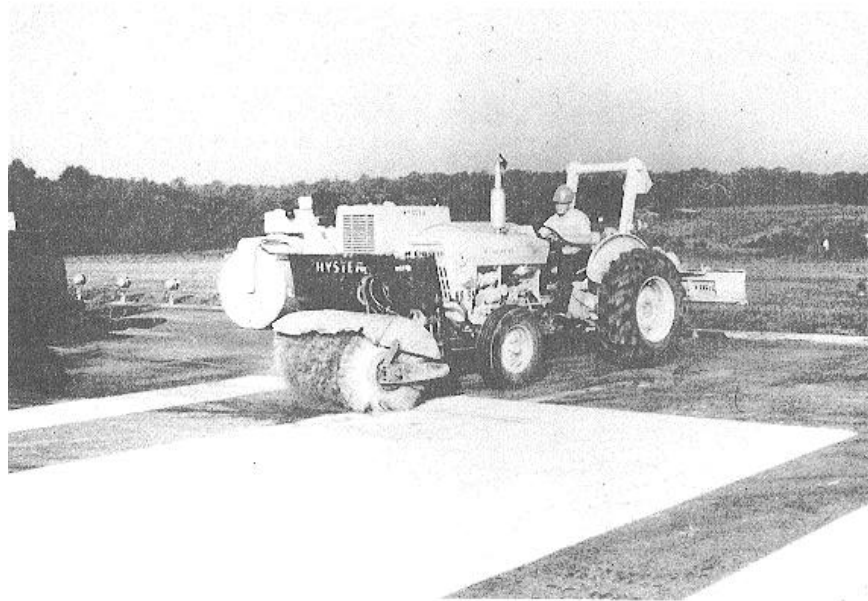


Figure 3-24. Motored circular broom.

d. *Squeegees.* The squeegee, a U-shaped blade of neoprene rubber attached to a long handle, is used to spread seal coats (fig 3-25) or to force the hot sealing material into cracks or joints. For joint sealing the squeegee is pushed along the crack or joint immediately after it is filled. The blade levels and strikes off any excess material to form a neat and effective crack seal.

e. *Power saws.* Pavement power saws are usually one-man-operated, dolly-mounted units that have

an abrasive circular blade. The saw is either manually pushed or mechanically driven as it cuts through the pavement surface. These saws are capable of cutting a straight line and leaving neat vertical sides. Small portable hand held saws can be useful for repairing small areas (fig 3-26).

f. *Cutting disks.* Cutting disks are circular, heavy-duty steel plates with a sharpened edge (fig 3-27). The disks are usually attached to a motor grader moldboard or scarifier, or some other piece of



Figure 3-25. Applying a seal coat with squeegees.



Figure 3-26. Hand held saw.

equipment such as a steel wheel roller. The cutting disk is much faster and cleaner (water is not used) than sawing and is recommended where larger areas of pavement must be removed. It must be noted, however, that the standard cutting disk is limited to approximately 3 inches maximum cutting depth.

*g. Jackhammers.* Jackhammers with proper chisels are commonly used for cutting and removing pavement surfaces (fig 3-28). When used by a Hand held saw.

skilled operator, this tool will produce a straightline cut with fairly vertical sides.

*h. Front-end loaders.* Front-end loaders are very useful in loading trucks when removing old pavement, transferring patching mixes, or other paving material.

*i. Dump trucks.* Dumptrucks are used in hauling deteriorated pavement and repair materials to and from the job site. Dump trucks may be end or bottom dump type.

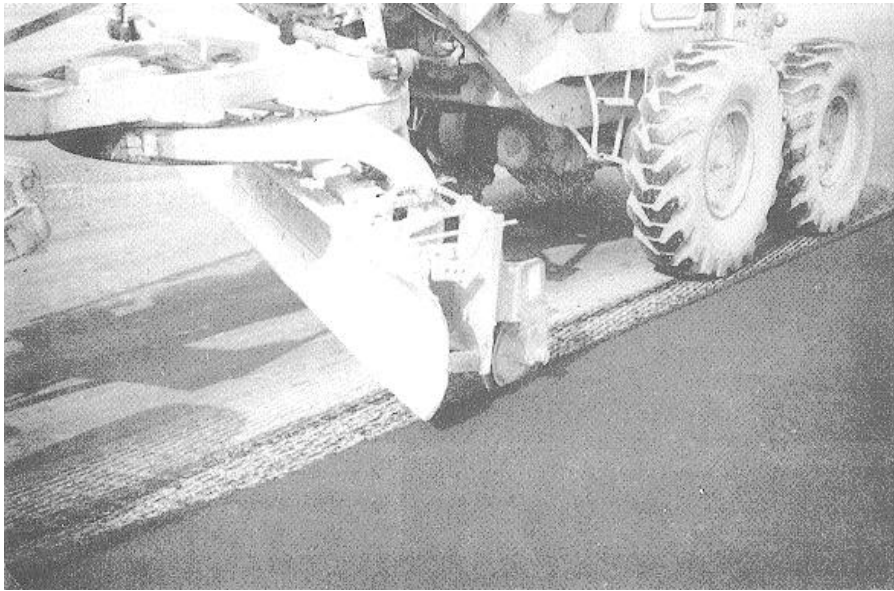


Figure 3-28. Removing damaged pavement with a jackhammer.



*j. Propane heaters.* Joint and patch propane heaters (fig 3-29) are occasionally used to heat and soften existing bituminous surfaces, thereby improving bonding and aiding in the curing of coldlaid patch materials. When using these devices, care must be taken in order to prevent damage to the pavement due to overheating.

*k. Heater scarifiers.* Heat scarifier equipment (fig 3-30) heats the pavement surface and then scarifies it to a depth of  $\sqrt{2}$  to 1 inch, depending on the pavement properties (density, aggregate type, etc.). A recycling agent and/or new asphalt is often added to the mix to increase the asphalt content to recommended levels. The scarified mix may be spread and compacted directly (fig 3-31) or it may be combined with new mix before compaction. A preheater is sometimes used to assist in properly heating the pavement before scarifying.

*l. Heater remixer* Heater remixers (fig 3-32) use a form of infrared or radiant heat to soften the bituminous pavement. After heating, the surface is then scarified to depths of  $\sqrt{2}$  to 2 inches. Separate or preheaters are used when required for greater depth or output. New asphalt binder may be added to the materials prior to compaction.

*m. Cold milling machine.* Cold milling machines (fig 3-33) are used to correct surface irregularities by milling the surface of the pavement without the use of heat. This equipment consists of a drum equipped with carbide-tipped bits which can cut up to approximately 4 inches of bituminous mix in one pass. The cutting teeth and run speed can be ad-



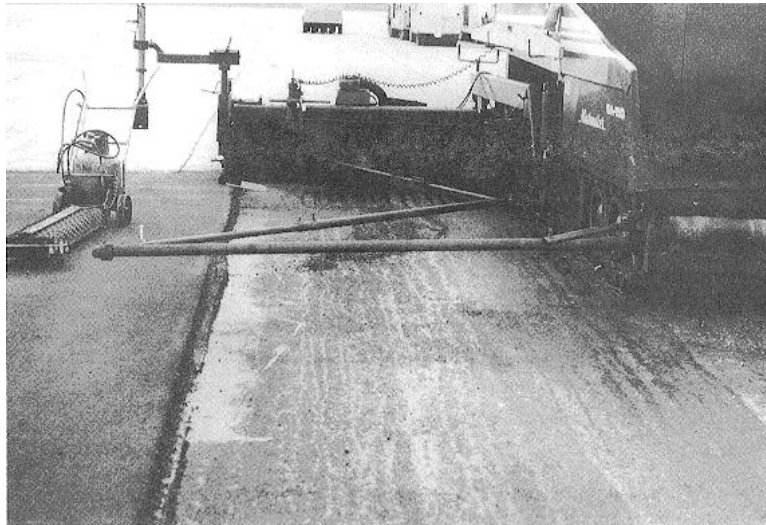


Figure 3-29. Propane joint heater

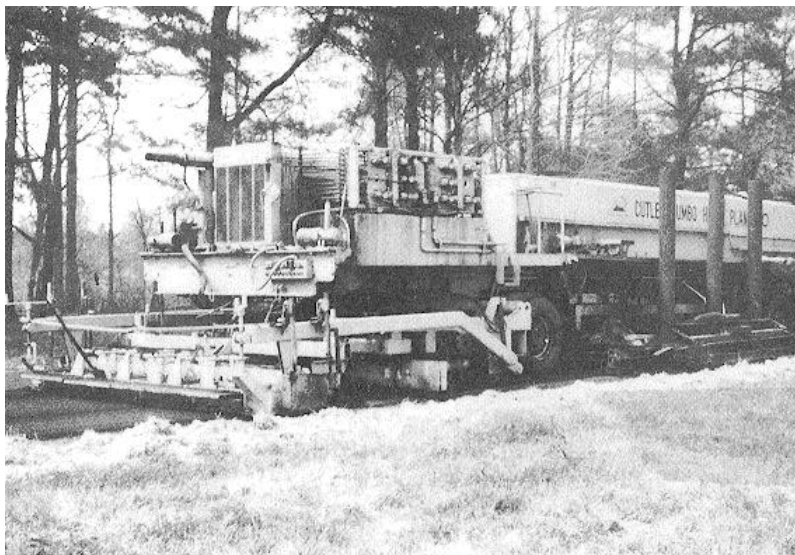


Figure 3-30. Heater scarifier with blade and spreader attachments.

adjusted to provide the desired surface texture. Some of the equipment has direct control of finished grade by the use of sensors that follow a stringline grade reference. The loose material removed from the pavement surface is usually suitable for use as base or fill material or for recycling into an asphalt base of surface course. Small milling machines for making small cuts such as utility cuts are also available (fig 3-34).

*n. Traveling hammer mill.* Traveling hammer mills (fig 3-35) are used to breakup pavement surfaces for

reconstruction or recycling. The material is usually broken down to pieces less than 2 inches in diameter. The hammer mill is composed of a series of hammer-like appendages which swing about a center drive shaft to strike and breakup the pavement surface (fig 3-36).

*o. Pulverizer.* A pulverizer is used to break up the pavement into pieces usually less than 1/2 inches in diameter. It can be used in conjunction with the

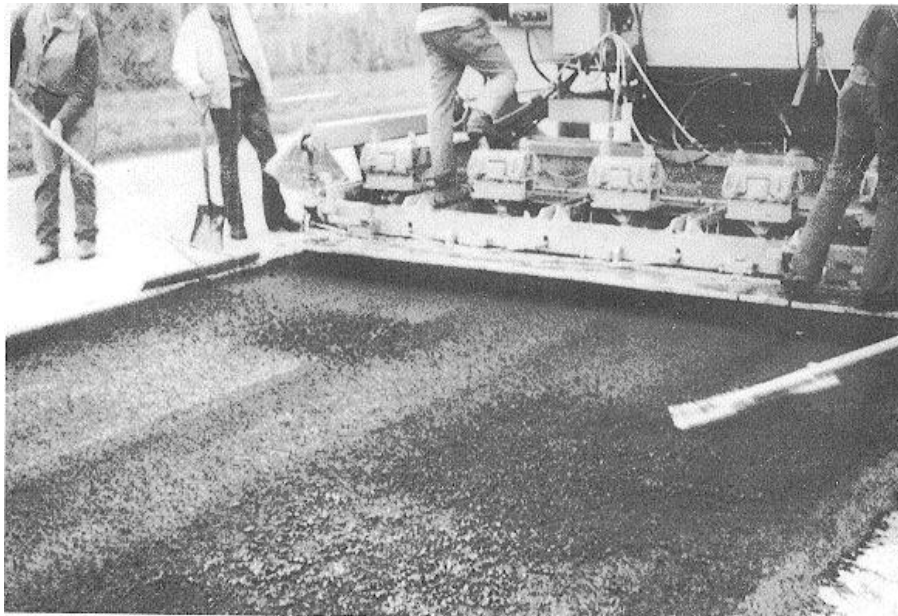


Figure 3-31. Scarified and bladed bituminous material being immediately respread and compacted.

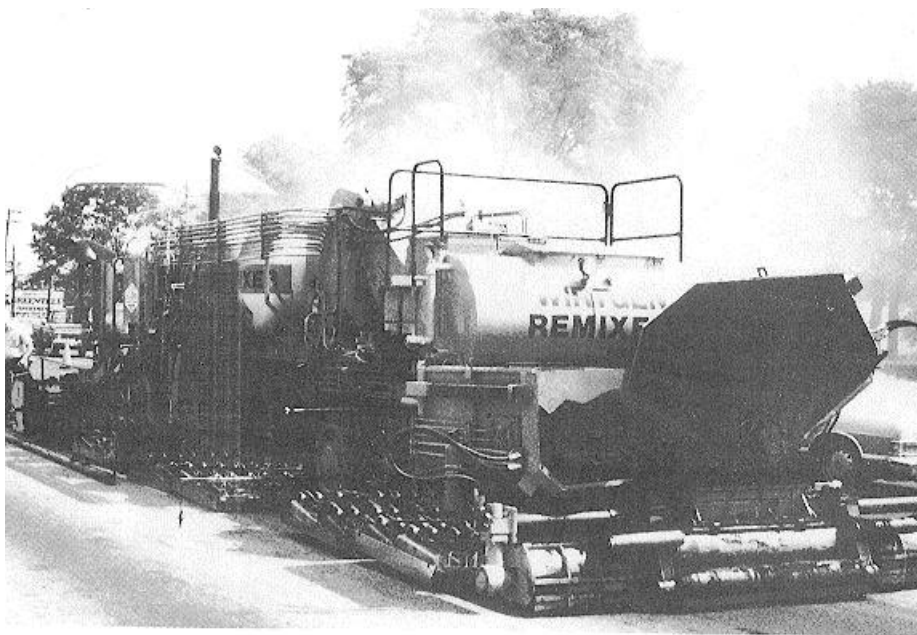


Figure 3-32. Heater remixer for in-place recycling.

traveling hammer mill to further break down the aggregate particles into smaller sizes. It is constructed similar to the hammer mill except that the appendages are more closely packed for finer breakage.

*p. Laydown.* Small portable hot-mix plants (fig 3-38) are occasionally used to produce hot-mix material at the job site. These units are trailer mounted and consist of a small aggregate dryer, a pugmill, and a bituminous storage tank contained on a single frame. The mix is

produced in the same manner as in a stationary plant. The aggregate is fed into the hopper and dried in the dryer. The hot bituminous material is added, and the material is mixed in the pugmill. Because of inaccuracies in job site proportioning of materials, it is difficult to produce a high-quality mix with the portable plant; however, satisfactory patching materials are not too difficult to produce.

*q. Stockpile-mix heaters.* Stockpile heaters are

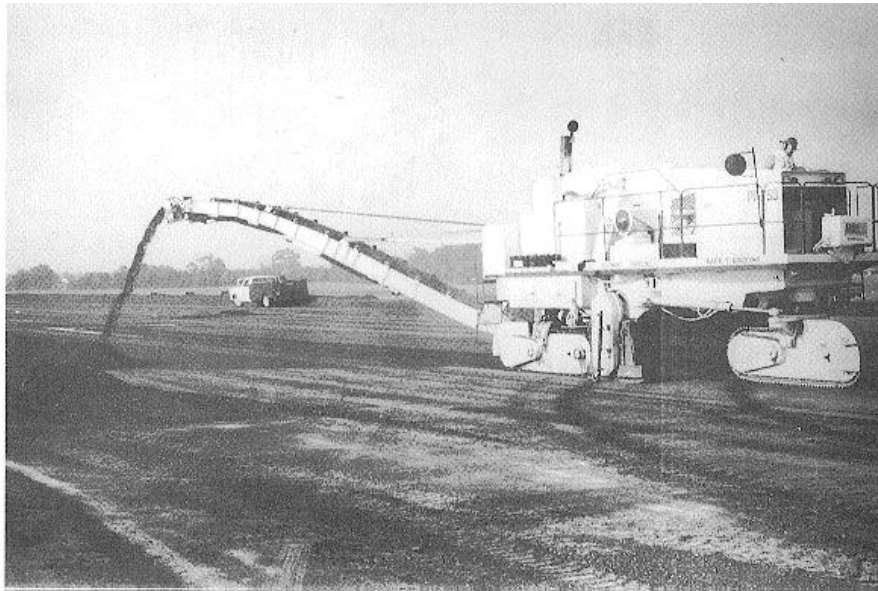


Figure 3-33. Cold milling machine.



Figure 3-34. Self-propelled pavement milling machine.

very convenient for producing small quantities of hot-mix materials that can be hot-laid from stockpiled cold-mix materials. The stockpile-mix heaters can be mounted to the tailgate of a dump truck; larger unit may be trailer-mounted. The unit has facilities for heating and remixing materials. The mixing area is covered and vented to permit safe heating and removal of the remaining volatiles in the cold mix. Units of this kind can be very valuable in a maintenance operation

because they make available an economical supply of hot-mix material for emergency repair.

r. *Bituminous distributors.* Bituminous distributors may either be truck or trailer-mounted (fig 3-39). Each unit is composed of a heater reservoir, a pump, and connecting spray bar. The spray bar is equipped with nozzles especially placed to permit even spraying of closely controlled amounts of liquid

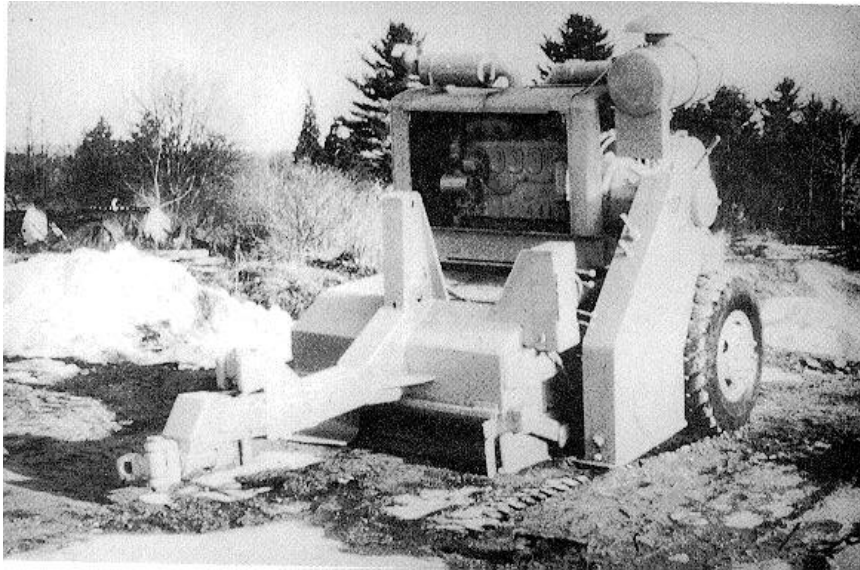


Figure 3-35. Traveling hammer mill.

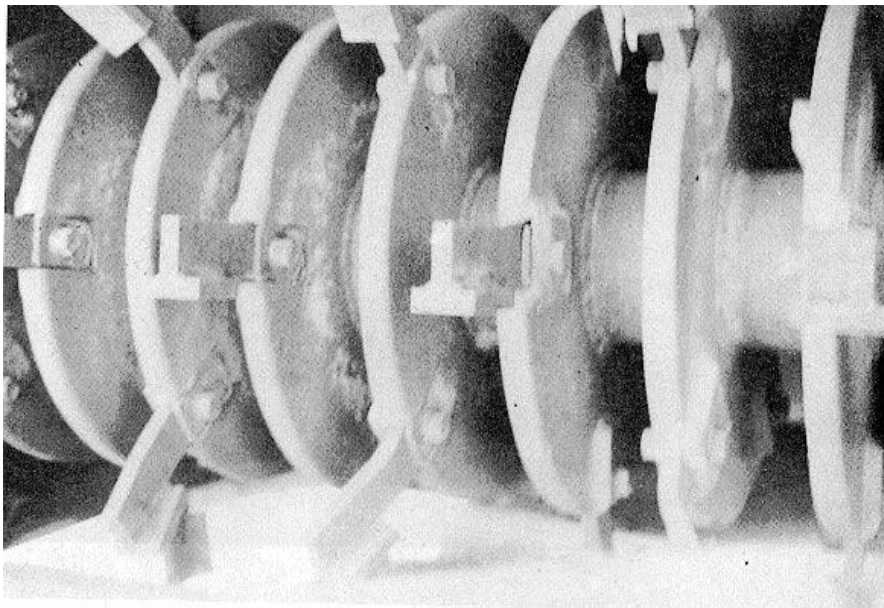


Figure 3-36. Close-up of hammer mill breaking shaft.

bituminous material. The distributor can be used for priming, tacking, and sealing bituminous surfaces.

s. *Asphalt kettle.* Asphalt kettles are used primarily in repair and maintenance work. They are small trailer-mounted units capable of heating and storing 40 to 500 gallons of bituminous material. A pump mounted on the trailer frame is used to force the liquid bituminous materials through spray nozzles located on the end of a hand-held hose. These units are used for priming and tack coating, in small patchwork,

and for crack or surface sealing of bituminous surfaces (fig 3-40).

t. *Aggregate spreaders.* Aggregate spreaders can be truck-mounted, separate units, or self-propelled (fig 3-41). They are used to evenly spread sand or aggregate. For pavement patching, a tailgate spreader, the most commonly used, is attached to the rear of a dump truck. The rate of application of the aggregate is controlled by adjusting

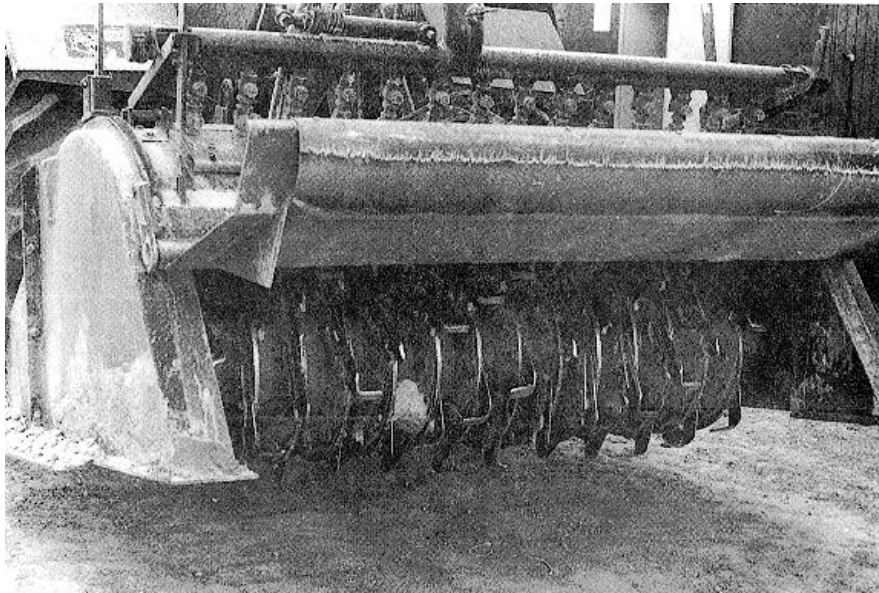


Figure 3-37. Close-up of pulverizer mixing blades.

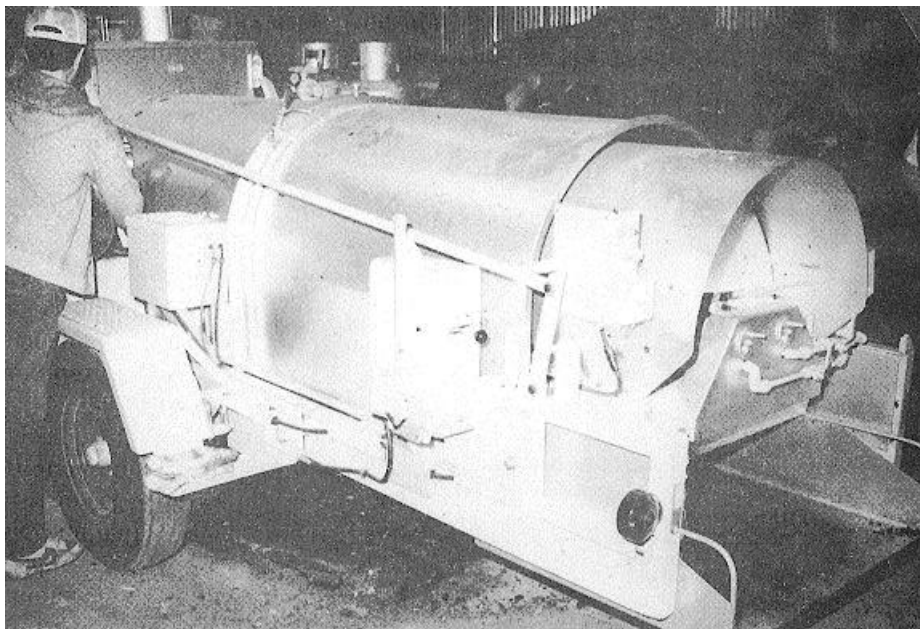


Figure 3-38. Portable hot-mix plant.

the spreader gate opening and auger screws. Spreader boxes and self-propelled spreaders are ordinarily used when large areas of surfacing are involved.

*u. Slurry machine.* Slurry seal machines (fig 3-42) consist of an aggregate storage bin, emulsion and water storage tanks, a mixing chamber, and a squeegee-type spreader box. Automatically proportioned aggregate, emulsion, and water are deposited in the mixing chamber and thoroughly mixed. After mixing, the

slurry is dumped into the spreader box and spread over the areas being sealed.

*v. Bituminous paving machine.* Bituminous paving machines or spreaders are used in placing bituminous (fig 3-43). These units are equipped with a material hopper, spreader screws, and a strike-off vibrating screen. The spreading widths vary from about 8 to 12 feet. The layer thickness can be varied from approximately 1/2 to 8 inches. The unit may also be used to place untreated aggregate.



Figure 3-39. Bituminous distributor.

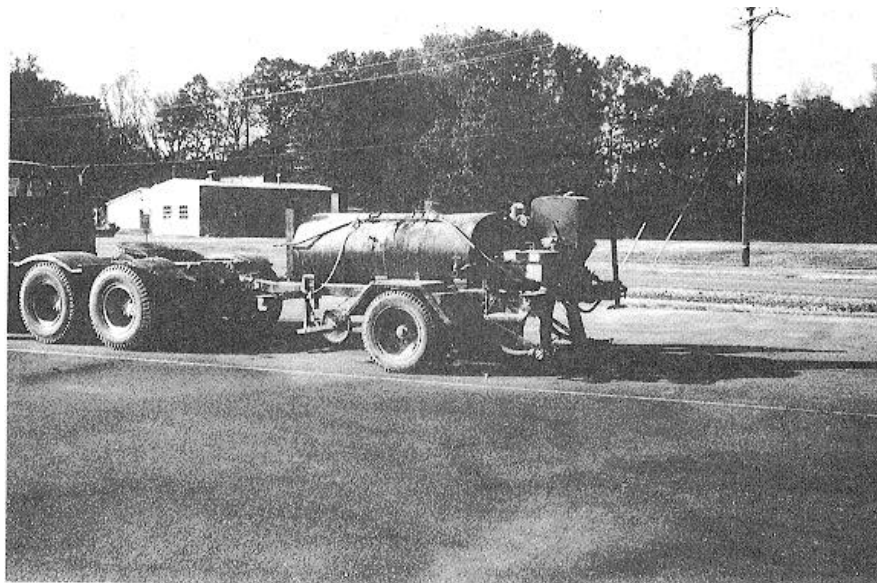


Figure 3-40. Asphalt kettle.

w. *Hand tamps.* Hand tamps are used to compact very small areas where other compaction devices are difficult or impossible to operate. The hand tamp is constructed by placing a handle on a weighted steel plate approximately 1/4 square foot or less. The tamp is pounded by hand to produce the proper density of a thin lift of soil, aggregate, or bituminous plant-mix. Vibratory plate compactors have engine-driven flat plates that vibrate at high frequency and low amplitude. The unit is usually hand-operated and is used for surface

smoothness and density in the top inch of the layer. Frequency range for this equipment is about 2,400 to 3,600 revolutions per minute (fig 3-44).

x. *Steel-wheel rollers.* Steel-wheel rollers (fig 3-45) are useful in obtaining a smooth compacted surface. They can be used for breakdown rolling or they can be used to remove the marks left by pneumatic rollers. These rollers are not suited for small repairs such as pothole and other small patches.

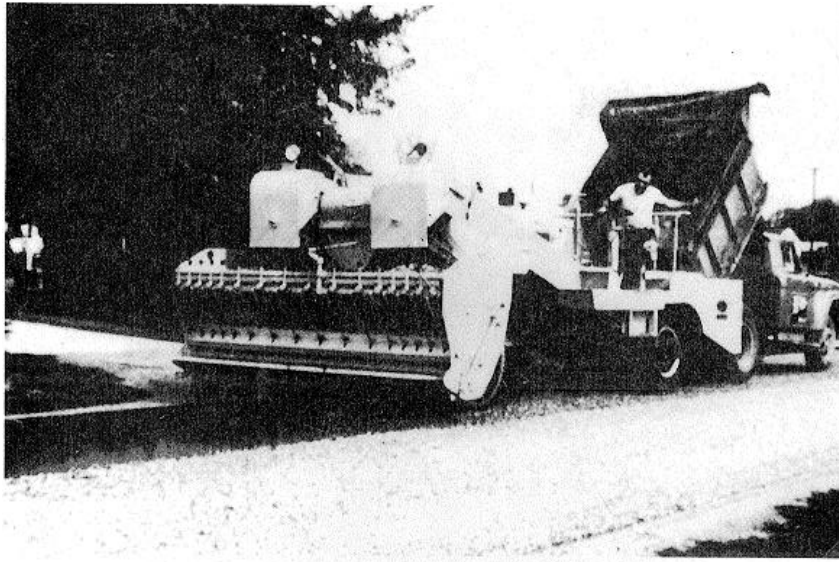


Figure 3-41. Self-propelled aggregate spreader.

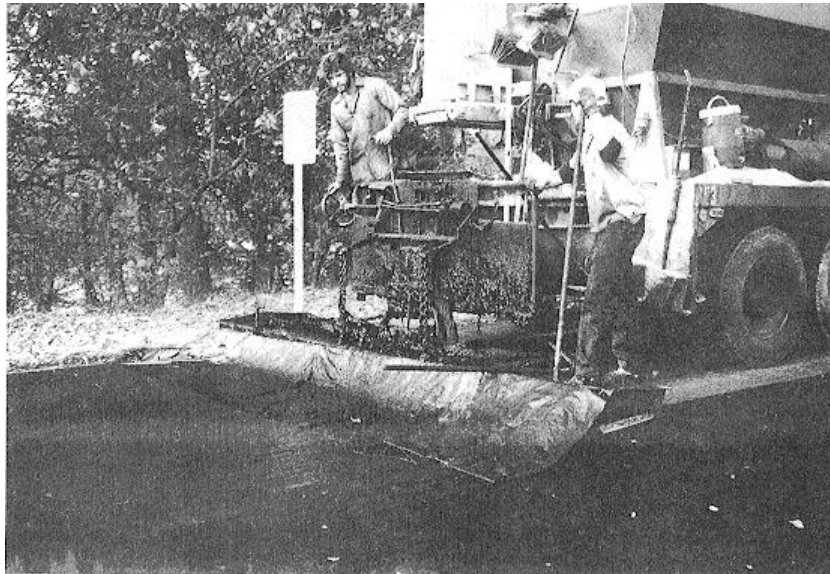


Figure 3-42. Slurry seal machines.

y. *Rubber-tired rollers.* Rubber-tired rollers (fig 3-46) are used when compacting large area patches. Their wheel action is more effective in obtaining the desired asphalt pavement density and a tight surface.

z. *Vibratory steel-wheel rollers.* Vibratory steel-wheel rollers (fig 3-47) can be motorized or hand operated and are frequently used for compaction patchwork. The rotation of a high-speed eccentric

weight produces a variable frequency and amplitude vibration of the drum that delivers the compaction effort. These rollers are best suited to compaction of granular materials and will produce a smooth, dense surface in bituminous patchwork. Results will be unsatisfactory if improper weight, frequency, or amplitudes are used. Thus, it is essential to have the equipment in proper adjustment for the type of material being compacted.

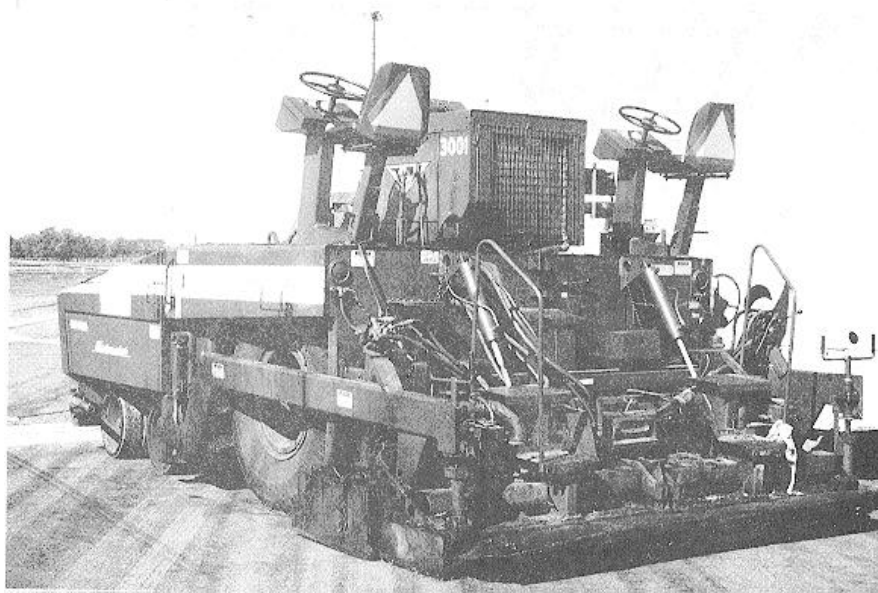


Figure 3-43. Asphalt paving machine.



Figure 3-44. Vibratory plate compactor.

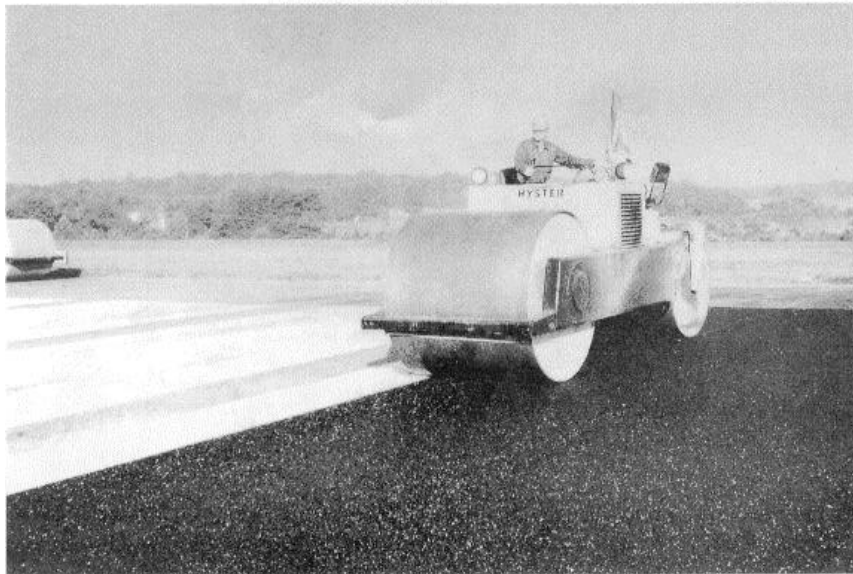
### 3-7. Bituminous repair methods

Repair methods used will normally be one of the following: crack sealing, skin patches, partial and full depth patches, pothole patching, surface sanding, surface treatments, fuel resistant seals or overlays, or porous friction course.

a. *Crack sealing.* Crack sealing in bituminous pavements is used to prevent the intrusion of water into the subgrade. Cracks less than 1/8 inch wide usually

can be treated satisfactorily by use of a seal coat. Cracks 1/8 inch or wider will be filled with a selected joint filler that meet Federal specifications for the type of pavement and service to which the pavement is to be subjected. Large cracks have also been filled successfully with a bituminous sand mixture using a slurry seal mixture or a hot-mix sand asphalt. All joint sealers will be applied at the maximum recommended temperature to ensure good penetration of the crack. Prior to apply joint filler,





]  
 Figure 3-45. Steel-wheel tandem roller.



Figure 3-46. Rubber-tired roller

the cracks will be routed out and cleaned by use of compressed air so that all loose particles are removed. If experience indicates a compatibility problem with reference to joint sealing material and the pavement, a sand-asphalt mix will be used to seal cracks. Procedures for sealing cracks in bituminous pavements can be found in TM 5-822-11/AFM 88-6, chapter 7.

*b. Skin patch.* A skin patch is usually placed on the pavement without removing any damaged pavement. A shallow trench with a vertical face is made

around the patch to help hold it in place. This is considered a temporary repair.

(1) The area should be cleaned with brooms and, if necessary, compressed air. A tack coat should be applied to the area.

(2) The skin patch should be placed with hot plant mix asphalt or if this material is not available, cold mix may be used. Coarse particles must be removed with a lute in order to feather the edges.

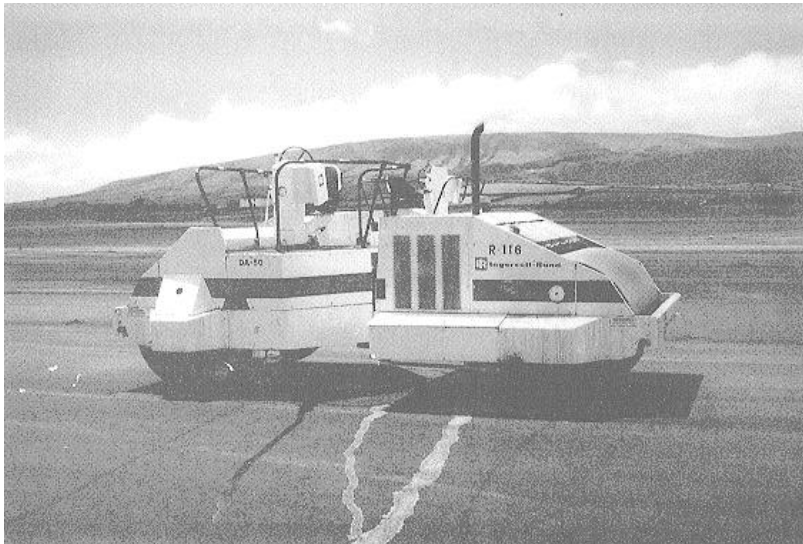


Figure 3-47. Steel-wheel vibratory roller.

(3) This material should be compacted with any available equipment. When necessary, compaction can be accomplished with the wheels of the truck used to transport the mix.

*c. Partial-depth patch.* A partial-depth patch will extend only as deep as necessary into the pavement to reach undamaged pavement.

(1) The edges of the patch should extend at least 1 foot into satisfactory pavement. The patch should be square or rectangular with vertical edges. The cuts should be made with a circular saw or a jackhammer.

(2) A light coat (0.05 to 0.15 gallon per square yard) of SS-1 or SS-1h asphalt emulsion diluted with equal parts of water should be applied to the cleared area. RC-70 may also be used. Tack coat should be allowed to cure until it becomes tacky to touch (fig 3-48).

(3) If available, enough hot-mix AC material should be spread into depression so that when compacted, it will bring the depression back to the original grade (fig 3-49). If the material has been carefully spread, allowance of approximately 25 to 50 percent overfill should correct for compaction. If edges of patch are feathered, coarse aggregate must be removed from the edges prior to compaction. If plant-mix cold-laid material must be used, it should be aerated as required before it is placed in the depression. Aeration dissipates the solvents and water that may cause an unstable patch. The same overfill for compaction as mentioned above will also be practiced.

(4) After material has been placed, it will be thoroughly compacted using a vibrating plate

compactor, roller, or hand tamper. If none of these are available, compaction can be obtained by truck wheels. Surface elevation will be checked by straightedge or string line for grade. If deficient, additional material may be raked into the surface and recompact. In the repair of deep depressions normally two or more layers of AC are required. The layers should be between 2 to 3 inches for hot mix. Filling the area by following the contour of the depression is sometimes mistakenly done. When this approach is followed, it is nearly impossible to obtain good uniform compaction or match the original pavement grade. The correct way to repair a deep depression is to begin in the deepest part of the depression and place a thin layer, the surface of which, when compacted, will be parallel to the original pavement surface. Successive layers are placed in the same manner. Otherwise, the backfilling is performed in the same manner as described above. Figure 3-50 shows the correct way and the incorrect way to place AC backfill in a deep depression.

*d. Full-depth patch.* A full-depth patch normally extends to the subgrade.

(1) The edges of the patch should extend at least a foot into good pavement outside of the damaged area. The cut should be square or rectangular with the sides vertical. This is normally accomplished with a power saw or jackhammer. The area should then be thoroughly cleaned.

(2) If the subgrade is damaged, it should be repaired.

(3) Apply a light tack coat to the vertical face and allow it to become tacky. If the patch is placed



Figure 3-48. Hole to be patched with tack applied



Figure 3-49. Placing asphalt mix in patch.

on subgrade, no prime is needed; however, if it is placed on a granular base, it should be primed.

(4) For best results, the entire area should be filled with dense-graded hot-asphalt plant mix. The patch should be backfilled and compacted in 2 to 3 inch lifts. A rubber-tire or vibratory roller should be used whenever possible along with the hand-held compactors. Partial backfilling of the hole with compacted granular fill and topping with hot mix can be done when there is a shortage of hot mix. Cold mix can be used when necessary, but it is not encouraged.

e. *Pothole patching.* Potholes require proper preparation and backfill. All material for filling these holes must meet certain standards.

(1) Temporary repair of potholes may be made with premixed cold-laid AC or hot-mix bituminous concrete. To place this material during inclement weather, the pothole is cleaned out and dried using a pavement heater or blow torch. The hole is then

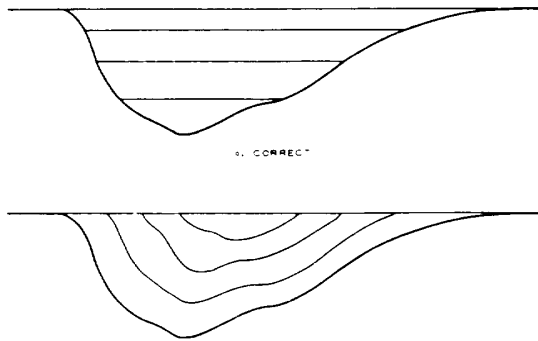
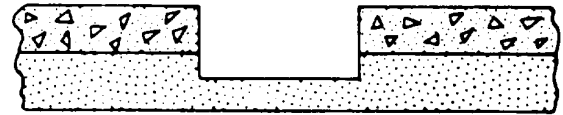
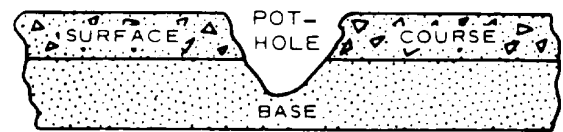


Figure 3-50. Placement of AC backfill in deep depression.

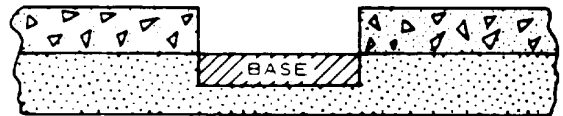
filled with the asphaltic material and compacted by hand tamp, mechanical tamper, roller, or loaded truck wheel. This temporary patch will be dislodged rather rapidly under traffic because the hole has not been properly prepared for a permanent patch.

(2) Permanent repair of potholes requires proper preparation and backfill. First, the hole should be squared up and deepened to hard, firm base. This may be done with a pavement saw, air hammer, and chisel or by hand hammer and chisel. It is important that the sides be cut vertical and the bottom rest in hard firm soil or base. Base material should be replaced with equal or better material than that removed or with bituminous paving material. This material will be thoroughly compacted by use of mechanical or hand tamps. After backfilling with the base material, the hole will be primed with a light asphalt material such as RC-70 and allowed to cure until the asphalt becomes tacky. The prime may be applied with a paint brush. The last step is to replace the pavement surface material. If possible, the paving material should be a good quality hot-mix material. The hole will be overfilled approximately 40 percent of its pavement thickness to allow for compaction. This should give a smooth impervious surface. If cold-laid material is used, the patch may have a porous surface and requires a sand or fine aggregate seal coat for waterproofing (fig 3-51).

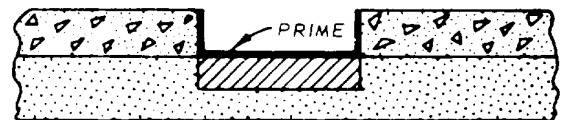
f. *Apply sand and remove.* This method is normally used where bleeding or flushing of asphalt has occurred. The repair is normally accomplished by placing hot sand or aggregate on the surface and embedding it by rolling. The surface will be cleaned of all loose debris or aggregate by brooming. When the surface is smooth, as on airfield areas, a natural sand is usually recommended. If most of the surface is rough and the bleeding is severe, a crushed sand should be used. If possible, the natural sand or crushed sand will be heated and placed on the area at a temperature of 275 degrees F or above.



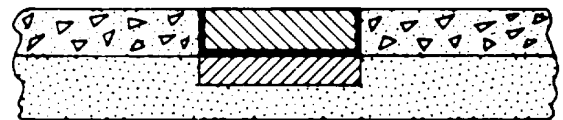
STEP 1  
TRIM (WITH VERTICAL SIDES)  
TO FIRM MATERIAL.



STEP 2  
REPLACE AND COMPACT  
BASE MATERIAL.



STEP 3  
PRIME BOTTOM AND  
SIDES OF PATCH.



STEP 4  
REPLACE PAVEMENT SURFACE WITH  
HOT-MIX (WHERE POSSIBLE) OR WITH  
PREMIXED COLD-LAID BITUMINOUS  
PAVING MATERIAL THOROUGHLY  
AERATED AND COMPACTED. COLD-  
MIX MAY LEAVE THE SURFACE POR-  
OUS AND REQUIRE SEALING WITH A  
SAND SEAL COAT.

Figure 3-51. Permanent repair of potholes.

Spreading is usually done at the rate of 10 to 15 pounds per square yard. Spreading may be accomplished using spreader boxes, tailgate spreaders, or by hand where small areas are involved. After a section has been spread, a rubber-tired roller will be used immediately (about 2 minutes maximum) to seat the hot natural sand or crushed sand into the softened binder. After the surface has cooled, any loose material will be swept off. If necessary, the treatment

**TM 5-624/NAVFAC DM MO-102/AFJMAN 32-1040**

may be repeated if the condition has not been permanently remedied.

g. *Surface treatments.* Surface treatments and materials are listed and discussed below.

(1) *Apply surface seal emulsion.* Surface seal (fog seal) can be a light application of asphalt or tar emulsion diluted with water. Most surface seals are used on sound plant-mix surfaces that have weathered, oxidized, fine cracks, and become brittle. When a diluted emulsion is used, it will flow into the fine cracks and form a thin coating on the pavement surface. After placing, the asphalt should cure until it is no longer tacky and then should be rolled with a rubber-tired roller. The kneading effect of the roller will aid in sealing the cracks. Asphalt emulsions surface seals may be placed at the minimum temperatures shown in TM 5-822-8/AFM 88-6, chapter 9 and NAVFAC DM-5. Care should be exercised in use of surface seals, and application should be in three or four increments; otherwise, there is a tendency on most of the surfaces for the seal material to make the surface slick, thus reducing the coefficient of friction. A cover aggregate will be used to prevent loss in surface friction. An application of medium curing asphalt emulsion can soften and enliven a weathered asphalt pavement surface. Rolling with a rubber-tired roller is also required to close the softened pavement surface. Before any surface seal is applied, the pavement surface will be thoroughly cleaned by rotary brooms, compressed air, or hand brooms. Any oil-softened areas will be removed and patched. Usually, the pavement surface should be dry and free of any loss debris; however, in the use of asphalt or tar emulsion, a slightly damp surface is beneficial.

(2) *Apply rejuvenator.* This method is used where the pavement surface is oxidized but not exhibiting any problems besides some possible light raveling and/or cracking. The rejuvenator is applied by a distributor truck with a spray bar (fig 3-52). The amount applied will depend on the condition and density of the pavement being rejuvenated. A normal range of application would be from 0.05 to .01 gallon per square yard. A small area should be selected for repair and sprayed with various rates in order to determine the amount repaired. This amount should be applied in two one-half coverages. Before spraying, the pavement should be swept and all loose material removed from the pavement. The pavement should be able to accommodate traffic within 24 hours. If too much is applied and it does not soak in, a slippery surface results, especially undesirable on airfields. It may be removed by applying sand to absorb the rejuvenator and then removing the sand. An adequate time frame, materials, and equipment should be allowed when appropriate.

(3) *Apply aggregate seal coat.* Sand and aggregate seal coats may be used to rejuvenate and seal the surface of weathered asphalt pavements and to seal porous asphalt pavement. These seals are constructed in the same manner as single-course bituminous treatments. The selected bituminous material is applied at the rate of 0.01 to 0.4 gallon per square yard, depending on the aggregate size and condition of the surface to which it is being applied. The bitumen will be applied at the temperature recommended for the selected material. Details of design and application temperatures may be found



*Figure 3-52. Applying rejuvenator*

in TM 5-228/AFM 88-6, chapter 9 or NAVFAC DM-5.

(4) *Slurry seals.* A slurry seal is a mixture of asphalt emulsion, crushed fine aggregate (1/8 to 1/4 inch), mineral filler, and water. The materials are combined in proportions to produce a mixture of slurry consistency and applied to the pavement surface. Before application, the pavement surface will be thoroughly cleaned by brooming or compressed air. If the pavement surface is saturated with oil or grease, it cannot be satisfactorily cleaned for slurry application. These areas must be replaced if a satisfactory bond between slurry and pavement surface is to be obtained. After the seal has set sufficiently to resist pickup, rolling it with a rubber-tired roller will give best results. Slurry seals require no heating, but best results are obtained when they are applied at an ambient temperature of 60 degrees F or higher. Slurry seals will not be used where traffic is heavy because they wear off quickly.

h. *Fuel resistant seal or overlay.* When continuous fuel spillage occurs on an asphalt surface, the binder becomes soft and is frequently leached away. This results in raveling of the surface aggregate and increased pavement deterioration. Kerosene, hydraulic fluid, jet fuel, oil, gasoline, and other such petroleum products are the main offenders. Tarrubber which has been used in spillage areas in the past is no longer available due to environmental concerns. Tar which is derived from coal rather than petroleum is only moderately affected by petroleum products. Tar products such as coal tar emulsion or tar concrete will be used in moderate fuel spillage areas. If areas are subject to severe fuel spillage, replacement of the area with PCC will be required. Areas subject to only occasional fuel spillage will usually heal without repair and only minor damage will result. All fuel spills should be immediately washed down with low pressure water.

i. Porous friction surface. A PFC is used to provide an increase in skid resistance and reduce hydroplaning on pavement surfaces.

(1) PFC requirements are given in TM 5922-8/AFM 88-6, chapter 9, and NAVFAC DM-5.

(2) The hot-mix PFC material will be spread and seated with a steel-wheel roller (normally 10 to 12 tons). No density is required; only the seating of the aggregate is required.

(3) If raveling occurs, it can be controlled by applying a light spray of asphalt emulsion to hold the aggregate in place and not close the voids.

(4) Sealing cracks across a PFC will reduce the PFC's internal drainage but will not greatly decrease the PFC's effectiveness.

(5) To repair a damaged PFC, all the damaged material must be removed and, if necessary, the underlying pavement repaired. The area is then cleaned and a light tack coat applied. The edges of the PFC should not receive any tack as this would seal the voids in the pavements.

(6) Delamination occurs when the PFC fails to bond to the underlying pavement. This can cause failure of the PFC under traffic.

(7) Rubber deposits or buildup are critical on a PFC as they decrease the PFC's effectiveness to provide skid resistance. There is no fully successful method to remove rubber deposits as most commonly used methods for removal will damage the PFC.

(8) Fuel spills on a PFC should be flushed with water as soon as possible. Care must be taken to not damage the PFC with high pressure water application, but the water should be allowed to flow onto the affected area. If the damage warrants, the affected PFC should be removed and replaced.

#### 4-1. Methods of procedures

This section described methods and procedures for maintenance, repair, and resurfacing of concrete pavements. Since surface failure must be corrected at the source, probable causes are discussed and repair measures are described. The principles outlined apply to reinforced and nonreinforced pavements for roads, airfields, parking areas, openstorage areas, and walks.

*a. Normal maintenance and repair.* Normal maintenance on concrete pavements consists principally of the care of joints, sealing of cracks, replacement of random broken slabs or similar sections, and the correction of minor settlement and drainage faults. Repair consists of the work required to restore a distressed pavement so that it may be used at its original designed capacity and/or accommodate the current mission.

*b. Description and composition.* Concrete is a material manufactured from portland cement, water, fine aggregate (sand), and coarse aggregate (gravel or crushed rock), with or without additives (air entraining, fly ash), developed to achieve the strength and durability of natural stone. Concrete generally achieves its initial set less than 1 hour after water is added and will become fairly hard within 6 hours. Concrete will continue to gain strength at an ever decreasing rate for many years as long as moisture is retained within the consolidated mass, and there is not adverse chemical reaction either internally or due to external action. For example, during the first days, the concrete will normally attain about 80 percent of its 28-day strength and about 75 percent of its 90-day strength if adequately cured. The concrete strength at 28-day is normally used in pavement design for roads and 90-day is normally used for airfields. If high-early-strength cement is used, less time is required for the concrete to develop design strength. If hydraulic cement which contains pozzolans is used as a replacement, the rate of strength gain, especially at the early ages, will be lower.

#### 4-2. Properties and behavior

Concrete pavement has a relatively long economic life when properly designed, constructed, and well maintained. In general, the economic life of pavement ends when (under the effects of traffic, weather, and lack of proper maintenance) it has broken into small unstable sections. Subsequently, unsatisfactory surface problems develop and costly, extensive maintenance is required. Durability is improved by keeping the surface smooth, especially at joints and cracks.

Maintaining the joints to minimize the infiltration of water and to prevent the entrance of incompressible foreign material is essential for long life. Frequent loadings greater than those for which the pavements were designed will cause early failure of the pavement.

*a. Rigidity.* Portland cement concrete is classified as a rigid pavement. Because of its beam action or resistance to bending, it can bridge small, soft, or settled areas of a subgrade. Overloading of concrete pavements can result from the applied loads being greater than the design load or the foundation support being reduced as a result of pumping, excessive moisture, etc. Once cracking has commenced, continued loading will cause additional cracks or breaks until complete failure of the pavement results (fig 4-1).

*b. Strength.* The design of concrete for use in pavements is based on limiting the tensile stresses produced within the concrete by applied loads. Flexural strength, which is a bending resistance property, is used in the design of a rigid pavement. Compressive stresses exist in concrete pavement slabs but in relation to the compressive strength are insignificant. The compressive strength is about 8 to 10 times the tensile strength. The relative strength as well as the durability is directly affected by the quality of the cement, purity of the water, and cleanliness, durability, and gradation of the aggregates. Other important factors include the water to cement ratio, density, amount and type of admixtures, proportioning and mixing of materials, and placement and curing methods.

(1) *Cement.* The characteristics of portland cement manufactured in the United States are reasonably standardized and meet rather stringent specifications regarding composition. Cement manufactured in foreign countries must be investigated carefully to determine physical and chemical properties before approval is given for use in the construction of U.S. military installations. The quality and composition of foreign manufactured cement may vary and may not meet U.S. Government specifications as few foreign countries have as close control of cement manufacture as the United States. The standard types of portland cement are discussed in the following paragraphs.

(a) *Type I-normal.* This type is used for general construction when not subject to sulfate attack and where hydration heat will not cause an objectionable rise in temperature.

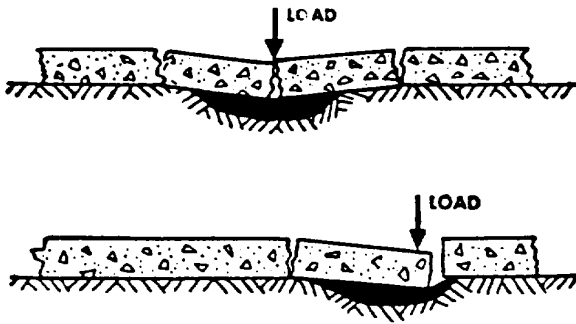


Figure 4-1. Pavement failures.

(b) *Type II-modified.* This cement has a lower heat of hydration than the normal Type I and generates heat at a slower rate. It is also a moderate sulfate-resisting cement. Modified cement is used when concrete is placed in warm weather or in locations where a high temperature rise is objectionable.

(c) *Type III-high-early-strength.* This type of cement is used where a high strength is needed very quickly. This may be due to a demand for early use or in cold weather construction to reduce the period of protection against low or freezing temperatures.

(d) *Type IV-low heat.* This cement is used when the amount and rate of heat generated must be kept to a minimum. Type IV cement develops strength at a slower rate than Type I cement, but prevents the development of high temperatures which can cause contraction cracking upon later cooling. Type IV is generally used for massive structures such as large gravity dams wherein temperature rise from the heat of hydration is critical. This type of cement will seldom, if ever, be used in maintaining and repairing pavements.

(e) *Type V-sulfate resistant.* Sulfates may be present in the water used to mix the concrete or may be created by sulfurous gases from nearby industrial areas and will react chemically with the cement compounds. Sulfate attack, however, occurs in foundations or other concrete in contact with the earth in certain regions, and it is caused by a reaction of the ground water containing dissolved reaction minerals or acid with the hardened cement. Type V cement is highly resistant to sulfate attacks. This cement is usually available only on special order.

(f) *Low-alkali cement.* When laboratory investigations or past-performance records demonstrate that the concrete aggregate (approved for a project) is potentially reactive with alkalis in the cement, the cement (regardless of type) should also be required to meet the requirements for low-alkali cement.

The combined sodium oxide and equivalent potassium oxide content shall not exceed 0.60 percent.

(2) *Water.* Water used in mixing should be clean and free from deleterious amounts of acids, alkalis, or organic materials. Generally, water ordinarily used for domestic and industrial purposes is suitable for use in mixing concrete. Seawater may be used if the salt content is not excessive. The detrimental effect on concrete caused by the use of seawater is usually small, except in very lean mixtures. But in reinforced concrete construction, the corrosion of the steel can be serious. A loss of 10 to 20 percent in compressive strength can be expected when using the same amount of seawater as fresh water. This can be moderately compensated by reducing the water-cement ratio. The maximum concentration of salt by weight allowed in the mixing water is about 1 percent of the weight of the cement.

(3) *Aggregates.* To ensure a dense composite mixture, the aggregate should be well graded from coarse to fine. Aggregates should be hard and sound to resist abrasion and weathering. They should not contain substances which react unfavorably with the chemical components of the cement used in the concrete mix. The maximum size of coarse aggregate used in pavement concrete should not exceed one-fourth of the pavement thickness. In no case should the coarse aggregate exceed 2-inch nominal size.

(4) *Admixtures.* An admixture for concrete is any material other than water, aggregate, or cement that is intentionally used as an ingredient in a concrete mixture and is added to the concrete batch either immediately before or during the mixing of the concrete. Admixture is used to make the concrete to which it is added more suitable or less expensive. An admixture will be used only when advantages cannot be more easily or more economically obtained in any other way. There are a number of categories of admixture:

- air entraining,
- retarding,
- water-reducing,
- air detraining,
- gas forming,
- expansion producing,
- finely divided minerals,
- damp proofing and permeability reducing,
- bond and chemical admixtures which reduce alkali-aggregate expansion,
- corrosion and inhibiting,
- fungicidal,
- germicidal,
- insecticidal,
- flocculating,
- coloring.



Only three of these admixtures mentioned will be discussed in this manual. A complete discussion of all admixtures is contained in the American Concrete Institute Guide for the Use of Admixtures in Concrete.

(a) *Air-entraining admixtures.* An air-entraining admixture generally has the properties of a soap or a detergent in that, when mixed with water, it will make foam. Adding an air-entraining agent in concrete will improve workability, reduce bleeding, and, most importantly, cause the concrete or mortar to be resistant to damage by freezing and thawing. The use of air entrainment permits the production of concrete that will not be damaged by freezing and thawing even though it is repeatedly frozen in a water-soaked condition. Concrete used for pavement should generally be air entrained containing between 4 and 7 percent by volume of air. Possible exceptions would include areas where aggregate strength is marginal and freeze-thaw is a negligible issue. When the proper amount of entrained air is added, the workability of the concrete will be greatly increased allowing the water content to be reduced which will increase the strength.

(b) *Accelerating admixtures.* Some accelerators used as admixtures change the time of setting without increasing early strength while others increase early strengths without changing the time setting. The most widely used accelerator is calcium chloride; this material can be safely used in amounts up to 2 percent by weight of the cement. Calcium chloride should never be used in prestressed concrete, in concrete in which there are embedded items such as aluminum electrical conduit, or in concrete that is placed on or in permanent metal forms, especially galvanized metal. Calcium chloride or any other accelerator should normally be used only in case of emergency, such as to accelerate set to prevent damage due to freezing or to open repaired areas to traffic within the shortest possible period of time. Caution should be exercised when using accelerators, such as calcium chloride, in hot weather as the time of setting will be substantially decreased.

(c) *Retarding admixtures.* Most retarding admixtures have a water-reducing effect which affects the setting time of the concrete. At normal temperatures and in normally used amounts, the setting time of concrete can be extended by one-third to one-half the normal time and greater delays obtained by using larger amounts of retarding admixtures. As with accelerators, retarders are normally used only in emergencies such as to prevent premature set on hot, dry, windy days.

(5) *Proportions.* The water-cement ratio theory should be observed when proportioning the amounts of water and cement in the mixture. A minimum of approximately 2½ gallons of water is required to hydrate (the chemical action which causes the concrete to harden) 94 pounds of cement. But more water must be added to compensate for evaporation and losses resulting from absorption by the aggregate in the concrete mixture, base, or subgrade and to provide fluidity which improves workability. Approximately 6 gallons of water per 94 pounds of cement represent the approximate maximum water-cement ratio which will produce a durable, frost-resistant concrete. Therefore, 4 to 5 gallons per 94 pounds of cement is generally considered adequate. Strength decreases proportionately as more water is added (fig 4-2). A high water content is not economical since the weakening effects on durability, compressive, tensile, flexural, and bond strengths, and weathering offset any apparent advantages of workability. The most practical method of proportioning available to the installation engineer, the book method, will normally be used if standard mixes are not available.

(6) *Book method of mix proportioning.* The selection of the quantities of cement, water, fine and coarse aggregates, and air-entraining admixture required to produce concrete of desired characteristics may be made from tables established for the purpose. The tables have been set up for aggregates having properties within the limits specified and will produce satisfactory quality concrete for such aggregates. The determined mix proportions are not always the most economical. Hence, the trial batch method will be used to design the mix when time is

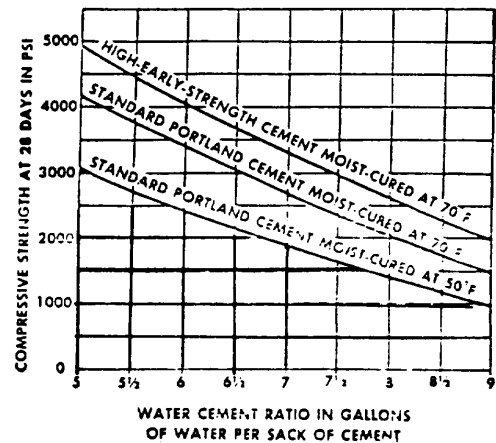


Figure 4-2. Age-strength relationship.

available and the size of the job warrants the laboratory effort required. The mix proportions given by the book method may be modified if the desired workability is not obtained. Such modification, as needed, will be made by changing the proportions of fine and coarse aggregate. The water-cement ratio should not be changed in making these modifications. The quantity of cement is established by the water requirement shown in table 4-1. Under field conditions where inspection and careful control of concrete quality are difficult, the cement content should exceed an established minimum. Recommended slumps (in inches) for various types of construction are given in table 4-2. The stiffness of the mix is inversely proportional to slump. In the absence of any criteria, concrete will be placed as stiff as possible while maintaining a homogeneous mass. The fineness modulus of the sand is determined by sieving or estimating. Tables 4-3 and 4-4 give mixes for air-entrained and nonairentrained concrete.

Using the water-cement ratio and aggregate size required, weights of water and cement should be selected per cubic yard of concrete.

(7) *Mixing and placing.* Thorough mixing is necessary to completely coat the aggregate with cement paste and to ensure the uniform distribution of all components. Care should be taken during transportation and placement of concrete to avoid segregation of the ingredients. Spading and vibrating are performed during concrete placement operations to ensure maximum density. These operations must be complete before the concrete takes its initial set. Good practice prohibits retempering of a concrete batch. A 1-minute minimum for actual mixing time is prescribed after all ingredients are in the mixer, and a maximum time is placed for completion of all mixing and placement operations.

Table 4-1. Approximate mixing water requirements for different slumps and maximum sizes of aggregates\*

Slump, in.	Water, gal/yd <sup>3</sup> of Concrete, for Indicated Maximum Sizes of Aggregate, in.			
	$\frac{1}{2}$	$\frac{3}{4}$	1	1- $\frac{1}{2}$
<b><u>Nonair-Entrained Concrete</u></b>				
1 to 2	40	37	36	33
3 to 4	44	41	39	36
5 to 6	46	43	41	38
Approximate amount of entrapped air in nonair-entrained concrete, percent	2.5	2	1.5	1
<b><u>Air-Entrained Concrete</u></b>				
1 to 2	36	33	31	29
3 to 4	39	36	34	32
5 to 6	41	38	36	34
Recommended average Total air content, ** percent	7	6	5	4.5

\* Mixing requirements are for reasonably well-shaped aggregates.

\*\* Air content will be designed for each project, based on materials to be used and experience.

Table 4-2. Recommended slumps for various types of construction

Types of Construction	Slump, in.*	
	Maximum	Minimum
Roads, streets, airfield pavements	2	1-1/4**
Bridge decks	2-3/4	2**
Sidewalks, driveways, and slabs on ground	4	2**

\* Based on use with high frequency vibrators. In no case will the slump exceed 4 inches.

\*\* When a slipform paver is used, the slump will be between 1/2 and 1-1/2 inches.

(8) *Temperature.* If concrete is exposed to elevated temperature, high wind velocity, and low relative humidity shortly after finishing, some of the mixing water will be lost to evaporation, and the surface will shrink, forming cracks in pavement. High temperatures will accelerate the hydration process resulting in more rapid strength gain as shown in figure 4-2 by the relative positions of the curves for curing at 70 and 50 degrees F. Concrete will be protected against freezing after placement for at least 14 days. If the concrete freezes, the hydration process stops, and there will be little or no strength gain.

(9) *Aging concrete.* Increase of strength with age is shown in figure 4-3. High-early strength is attained by the use of normal proportions of high-early-strength cement, the use of additional standard portland cement (25 percent), or the addition to the mix of not more than 2 percent (by weight of cement) of calcium chloride.

**4-3. Causes of concrete pavement distress**

Detailed distress identification criteria can be found in AFR 93-5 for airfields and TM 5-623 for vehicular pavements. Table 4-5 lists pavement distresses and suggested maintenance and/or repair procedures.

a. *Expansion and contraction.* Various methods for expanding and contracting concrete are listed below.

(1) *Temperature effects.* Concrete expands when temperatures increase and contracts when temperatures decrease. Pavement slab tends to lengthen in hot weather and shrink in cold weather.

(2) *Moisture effects.* Concrete expands as it absorbs moisture and contracts with loss or evaporation of the moisture. This may affect temperature stresses, depending on conditions. If rainfall is followed by hot weather, the effects combine and slab expansion may result in blowups. However, if a temperature drop immediately follows the precipitation, slab expansion and contraction may counteract each other, and no dimension changes will be noticeable.

Dense concrete resists water absorption. In cold climates, concrete containing an excess of entrapped air, if filled with water, may disintegrate as a result of freezing and thawing. The use of airentaining agents minimizes this. Maximum combined temperature and moisture stresses do not normally exceed the resistant limits of good quality concrete pavement, especially if joints are maintained free of noncompressible material to provide for free slab movement.

(3) *Joint movement.* Transverse and longitudinal joints are constructed in the concrete pavements to relieve stresses caused by volume changes and to prevent development of undesirable and unsightly cracks.

(a) *Expansion joints.* Expansion joints are installed primarily to relieve compression stresses caused by expansion of the pavement. They usually consist of some form of nonextruding filler such as wood, asphalt, impregnated fiberboard, spun glass, or other preformed elastomeric or compressible material which will permit horizontal expansion of the concrete. Expansion joints are used to isolate slabs from other features that move differently such as manholes, buildings, adjacent slabs with different working joint plans, and mismatched joints. Mismatched joints can cause cracks in adjacent slabs.

(b) *Contraction joints.* Contraction joints are installed to relieve tensile stresses due to contraction of the pavement. They are weakened planes usually consisting of grooves sawed or formed or materials inserted in the surface of the concrete. These grooves or separations are intended to reduce the pavement cross section at prescribed locations

Table 4-3. Suggested trial mixes for air-entrained concrete of medium consistency (1- to 2-inch slump)

Water-Cement Ratio lb/lb	Maximum Size of Aggregate in	Air Content Percent	Water lb/yd <sup>3</sup> of Concrete	Cement, lb/yd <sup>3</sup> of Concrete	Aggregate, Percent of Total Aggregate	With Fine Sand- Fineness Modulus = 2.50			With Coarse Sand- Fineness Modulus = 2.90	
						Fine Aggregate, lb/yd <sup>3</sup> of Concrete	Coarse Aggregate, lb/yd <sup>3</sup> of Concrete	Fine Aggregate, Percent of Total Aggregate	Fine Aggregate, lb/yd <sup>3</sup> of Concrete	Coarse Aggregate, lb/yd <sup>3</sup> of Concrete
0.37	1/2	7.5	300	815	41	1060	1520	46	1180	1400
	3/4	6	275	750	35	970	1800	39	1090	1680
	1	6	265	715	32	900	1940	36	1010	1830
	1-1/2	5	245	665	29	870	2110	33	990	1990
0.42	1/2	7.5	300	720	43	1140	1520	47	1260	1400
	3/4	6	280	665	37	1040	1800	41	1160	1680
	1	6	265	635	33	970	1940	37	1080	1830
	1/2	5	245	590	31	930	2110	35	1050	1990
0.47	1/2	7.5	305	650	44	1200	1520	49	1320	1400
	3/4	6	280	600	38	1100	1800	42	1220	1680
	1	6	270	570	34	1020	1940	38	1130	1830
	1-1/2	5	250	530	32	980	2110	36	1100	1990
0.52	1/2	7.5	305	590	45	1250	1520	49	1370	1400
	3/4	6	285	545	39	1140	1800	43	1260	1680
	1	6	270	520	35	1060	1940	39	1170	1830
	1-1/2	5	250	480	33	1030	2110	37	1150	1990
0.56	1/2	7.5	300	540	46	1290	1520	50	1410	1400
	3/4	6	280	500	40	1180	1800	44	1300	1680
	1	6	265	475	36	1100	1940	40	1210	1830
	1-1/2	5	245	440	33	1060	2110	37	1180	1990
0.61	1/2	7.5	305	500	47	1330	1520	51	1450	1400
	3/4	6	280	460	40	1210	1800	44	1330	1680
	1	6	270	440	37	1130	1940	40	1240	1830
	1-1/2	5	250	410	34	1090	2110	38	1210	1990
0.66	1/2	7.5	305	465	47	1360	1520	51	1480	1400
	3/4	6	285	430	41	1240	1800	45	1360	1680
	1	6	265	405	37	1160	1940	41	1270	1830
	1-1/2	5	250	380	34	1110	2110	38	1230	1990

Table 4-4. Suggested trial mixes for nonair-entrained concrete of medium consistency (1- to 2-inch slump)

Water-Cement Ratio lb/lb	Maximum Size of Aggregate in	Air Content Percent	Water lb/yd <sup>3</sup> of Concrete	Cement, lb/yd <sup>3</sup> of Concrete	Aggregate, Percent of Total Aggregate	With Fine Sand- Fineness Modulus = 2.50		With Coarse Sand- Fineness Modulus = 2.90		
						Fine Aggregate, lb/yd <sup>3</sup> of Concrete	Coarse Aggregate, lb/yd <sup>3</sup> of Concrete	Fine Aggregate, Percent of Total Aggregate	Fine Aggregate, lb/yd <sup>3</sup> of Concrete	Coarse Aggregate, lb/yd <sup>3</sup> of Concrete
0.37	1/2	2.5	340	915	42	1100	1520	47	1220	1400
	3/4	2	315	850	35	960	1800	39	1080	1680
	1	1.5	300	815	32	910	1940	36	1020	1830
	1-1/2	1	280	750	29	880	2110	33	1000	1990
0.42	1/2	2.5	340	810	44	1180	1520	48	1300	1400
	3/4	2	315	755	37	1040	1800	41	1160	1680
	1	1.5	300	720	34	990	1940	38	1100	1830
	1-1/2	1	280	665	31	960	2110	35	1080	1990
0.47	1/2	2.5	345	730	45	1250	1520	49	1370	1400
	3/4	2	320	680	38	1100	1800	42	1220	1680
	1	1.5	305	650	35	1050	1940	39	1160	1830
	1-1/2	1	280	600	32	1010	2110	36	1130	1990
0.52	1/2	2.5	345	665	46	1310	1520	51	1430	1400
	3/4	2	320	620	39	1150	1800	43	1270	1680
	1	1.5	305	590	36	1100	1940	40	1210	1830
	1-1/2	1	285	545	33	1060	2110	37	1180	1990
0.56	1/2	2.5	340	610	47	1350	1520	51	1470	1400
	3/4	2	315	565	40	1200	1800	44	1320	1680
	1	1.5	300	540	37	1140	1940	41	1250	1830
	1-1/2	1	280	500	34	1090	2110	38	1210	1990
0.61	1/2	2.5	340	560	48	1390	1520	52	1510	1400
	3/4	2	320	525	41	1230	1800	45	1350	1680
	1	1.5	305	500	38	1180	1940	41	1290	1830
	1-1/2	1	280	460	35	1130	2110	39	1250	1990
0.66	1/2	2.5	345	520	48	1430	1520	53	1550	1400
	3/4	2	320	485	41	1270	1800	45	1390	1680
	1	1.5	305	465	38	1210	1940	42	1320	1830
	1-1/2	1	285	430	35	1150	2110	39	1270	1990

so that cracks will occur below the weakened plane conforming to a given pattern.

(4) *Warping.* Variations in temperature and moisture conditions between the top and the bottom of concrete pavement cause warping or curling. During the day, surface temperatures may rise a number of degrees while the bottom of the slab, which is protected, remains at a lower temperature. This lengthens the surface dimension while the bottom dimension remains about the same. The slab tends to warp and curl downward at the edges and joints (fig 4-4). At night, the surface drops in temperature much more rapidly than the bottom, and the slab tends to curl upward to the edges.

b. *Surface texture.* The surface texture of PCC pavements will depend on the type and amount of finishing that was done during construction. In some cases, the type of aggregate used will determine the surface condition. Pavement slipperiness has been a major concern on highways and airfields, and in recent years directional control for vehicles attempting to stop on wet pavement surfaces has been obtained by grooving pavements. Grooving is accomplished by sawing of the hardened concrete. Plastic grooving has been used with some success; however, sawing gives the better surface texture.

c. *Construction deficiencies.* Deficiencies in the aggregate used will lead to deficiencies in the concrete. The use of aggregates susceptible to polishing should be avoided whenever possible.

The use of polishing aggregate can lead to a loss of skid resistance.

(1) *Unseasonable operations.* Concrete cures and gains strength with time. Extremes in temperature, hot or cold, can have a detrimental effect on the short and long-term properties of the concrete (see para 4-1c(8)).

(2) *Improper mixing.* Uncoated aggregate caused by improper mixing will decrease the strength and durability of the concrete. Proper mixing and handling during transportation are important to assure a good concrete mixture (see para 4-1c(7)).

(3) *Poor proportioning.* An improper proportion of any of the ingredients added to the mix can cause distress in the concrete. The degree of distress will depend on the degree of variation from the desired proportion (see para 4-1c(5)).

(4) *Placement errors.* Any placement errors such as over vibrating and segregation will cause pavement distress. These errors can be eliminated by good workmanship and good quality control (see para 4-1c(7)).

d. *Water intrusion.* Concrete pavements require a base with adequate strength in order to perform well. Any water allowed to infiltrate into the base will damage the base and therefore shorten the concrete pavement useful life. Adequate sealing of

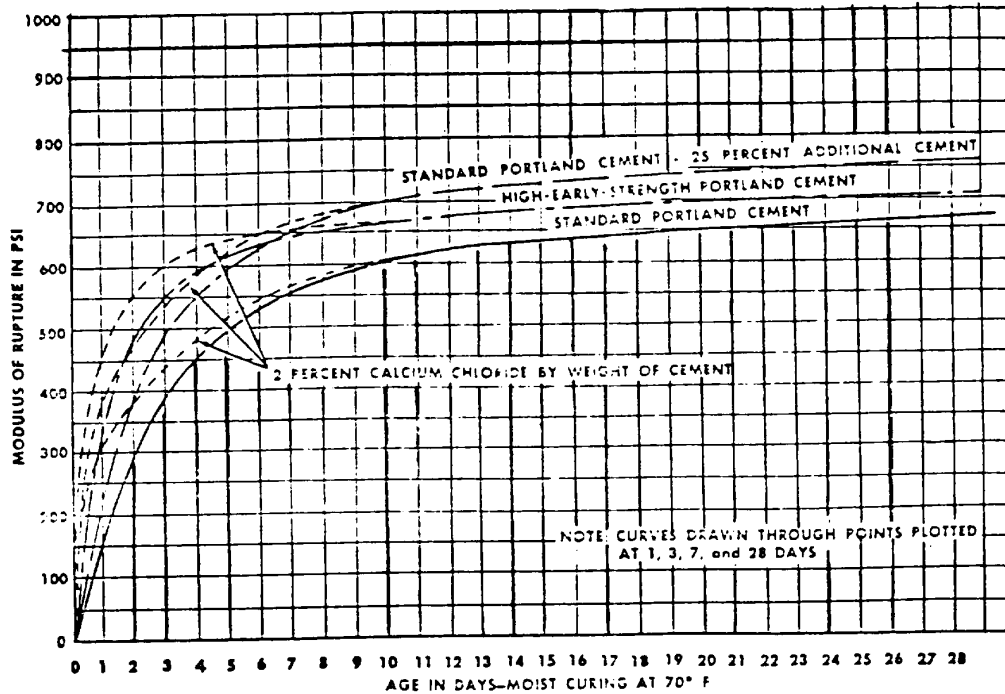


Figure 4-3. Approximate bending strength.

Table 4-5. Pavement distresses and suggested maintenance and/or repair procedures

Distress Type	Do Notb- ing	Partial Depth Patch (Bonded)	M&R Method								Notes	
			Full Depth Patch	Slab Replace- ment	Crack Seal- ins	Joint Seal- ins	Under Seal- ins	Slab Jack- Grout	Grind- ins Slab	Groov- ing		
21 Blow-ups		L*,M*	H*	H*								*Must provide expansion joint
22 Corner break	L		M,H	H	L,M,H							
23 Divided slab				M,H	L,M							
24 "D" cracking	L	M,H	M,H	H	L*		L*					*If "D" cracks exists, seal all joints and cracks
25 Faulting	L			H					M,H	M,H		
26 Joint seal damage	L						M*,H					*Joint seal local areas
27 Lane/shoulder drop of	L											If predominant, level off shoulder, apply aggregate seal coat
28 Linear cracking	L	H*	H	H	L,M,H							*Allow crack to continue through patch except when using A-C
29 Large patch & utility cuts	L	M*,H*	H*	H	M							*Replace patch
30 Small patching	L	M*,H*	H*		M							If predominant, apply major or overall repair e.g., overlay grooving
31 Polished aggregate	A											
32 Popouts	A											
33 Pumping						A	A	A				
34 Punchouts	L		M,H	H	L,M							
35 Railroad crossing	L											If n or H, level surface
36 Scaling/map cracks/crazing	L	M,H	H									
37 Shrinkage cracks	A											
38 Corner spalling	L	L,M,H										
39 Joint spelling	L	M,H	M,H*				L					*If caused by keyway failure, provide load transfer

**Note: L = low severity; M = medium severity; H = high severity; A = has only one severity level.**

cracks and joints will prevent water infiltration and subsequent pumping of certain types of soil.

e. *Fuel spills.* Concrete pavements are desirable for use in areas subject to fuel spillage. Concrete pavements are themselves not affected by fuel spills, but in these areas the use of fuel resistant joint and crack sealers is required. Any fuel resistant joint sealer must pass Federal Specifications SS-S-1614B or SS-00200E with the latter required where the sealer would be subject to jet blast.

f. *Chemical intrusion.* Chemical intrusion refers to the concrete's chemical reaction to other materials. The most widespread problem normally encountered is with deicing salts in cold weather regions. The reactions vary with the type of cement and the quality of the aggregate used. Chemical intrusion problems can be reduced by selecting the proper construction materials for the conditions encountered.

g. *Wheel load transfer.* Failure to provide for wheel load transfer across joints (especially during

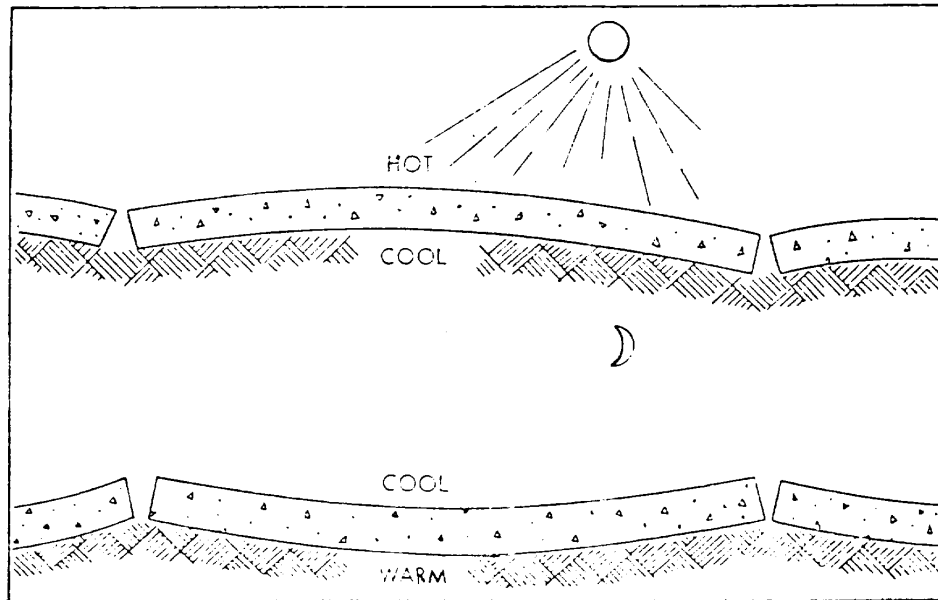


Figure 4-4. Curling.

repairs and slab requirements). Paragraph 21a(2) gives an explanation of load transfer.

*h. Poor joint layout.* Poor joint plan layout or violation of a good jointing plan during repairs and slab replacement can cause premature failure. Repairs need to observe the existing plan and provide for proper joint movement (and load transfer). Large slab repairs (all edges) should not be confined without some means of concrete drying construction relief.

#### 4-4. Types of concrete pavement distress

Distresses are of many types. Some pavement distresses are listed below.

*a. Blowups.* A buckling blowup (fig 4-5) is the localized upward movement of a rigid pavement. The buckling may take the form of a rather serious blowup or may merely shatter the upper portion of the concrete near the joint. This condition is caused primarily by infiltration of incompressible material in joints and possible growth of the concrete. During hot weather, the pressure due to the slab expansion builds up at transverse cracks or joints until buckling or shattering occurs. Buckling or blowups normally occur in thin pavement sections.

*b. Corner break.* A corner break in a rigid pavement (fig 4-6) is a break which occurs along the edge or corner of a slab. The corner break has the approximate shape of a triangle, the sides of which are formed by a transverse joint or irregular crack and a longitudinal joint or slab edge. Corner breaks are caused by overloading or a loss of uniform subgrade support.

The lack of proper support may be caused by curling or warping in the slab, voids from pumping of the supporting material below the broken or cracked corner, or loss of load transfer at the transverse and longitudinal joints.

*c. Divided slab (shattered).* A divided slab is divided by cracks into four or more pieces due to overloading and/or inadequate support (fig 4-7). These cracks are usually vertical and extend full depth through the slab.

*d. "D" cracking.* Another type of cracking, termed D cracking (fig 4-8), is the progressive formation on the surface of a series of fine cracks at rather close intervals, paralleling edges and joints, and curving around corners where joints intersect or cracks intersect edges. It is caused by repetitive freezing and thawing cycles in the presence of aggregates of varying expansiveness and those having an undesirable pore structure. Moisture is critical to the development of D cracking. Thus, if excess moisture can be kept out of the concrete, this type of distress can be retarded.

*e. Faulting.* When filled areas are not thoroughly and uniformly compacted, differential consolidation or settlement of material underlying the slabs can occur, resulting in faulting of concrete slabs (fig 4-9). This condition may result from loss of fines (through improperly designed subdrains or other drainage systems), pumping under traffic, differential frost heave, and swelling soils.



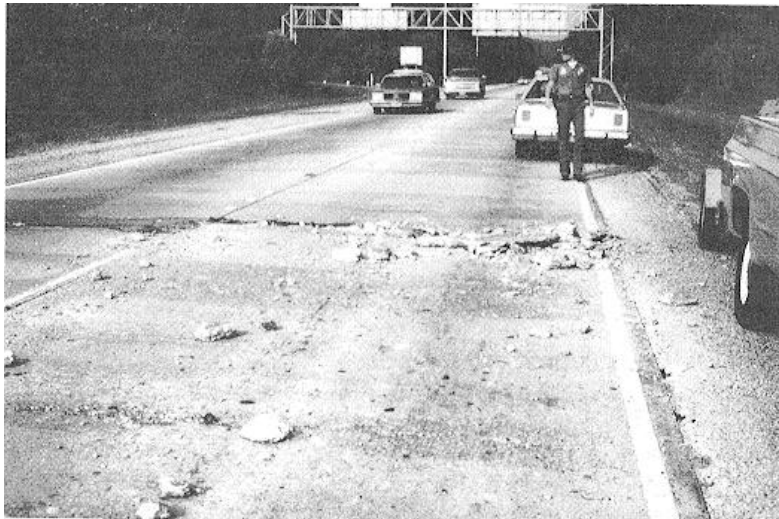


Figure 4-5. Blowup/buckling.



Figure 4-6. Corner break.

f. *Joint seal damage.* Joint seal damage is any condition which enables material to accumulate in the joints or which allows significant water infiltration through the joint (fig 4-10). Accumulation of incompressible materials in the joints prevents the slabs from expanding and may result in buckling, shattering, or spalling. A properly applied pliable joint sealer bonded to the edges of the joint will protect the joint from material accumulation and subsequent water infiltrations. Typical types of joint seal damage are

- (1) Stripping of joint sealant.
- (2) Extrusion of joint sealant.
- (3) Weed growth.
- (4) Hardening of the sealer (oxidation).
- (5) Loss of bond to the slab edges.
- (6) Lack or absence of sealant in the joint.

g. *Lane/shoulder dropoff.* Lane/shoulder dropoff is the differential settlement or erosion between the shoulder and the pavement-lane edge (fig 4-11). It can also be caused by differential heave (frost heave). This drop off can be severe safety hazard for



Figure 4-7. Divided slab.

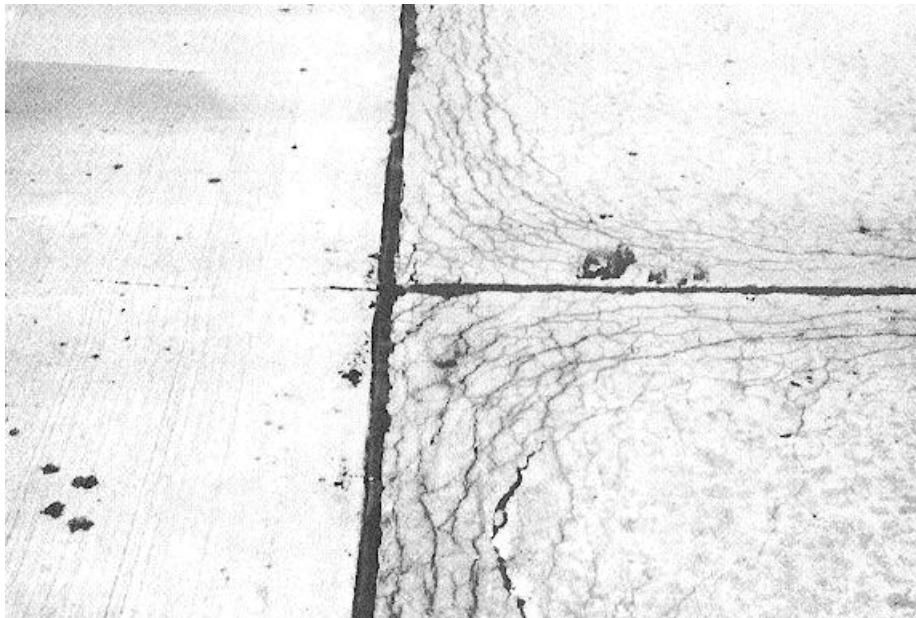


Figure 4-8. D cracking

vehicles which cross it. This distress can also cause increased water infiltration and subsequent damage.

*h. Linear cracking (longitudinal, transverse, and diagonal).* Linear cracks can be either longitudinal, transverse, or diagonal depending on the orientation of the crack. These cracks usually divide the slab into two or three pieces. Linear cracks (fig 4-12) can result from a number of individual or a combination of causes.

These causes include the following: (1) traffic, (2) lateral contraction or shrinkage of the concrete, (3) lateral warping or curling of the slab, (4) loss of support under the edge of the slab due to nonuniform support, (5) pumping, (6) the presence of expansive subgrade soils under the pavement, (7) and heavy loads. Longitudinal cracking usually occurs in thin slabs 16 feet or more in width without the benefit of a proper longitudinal joint. Transverse cracking occurs at right angles to longitudinal joints. There are several potential

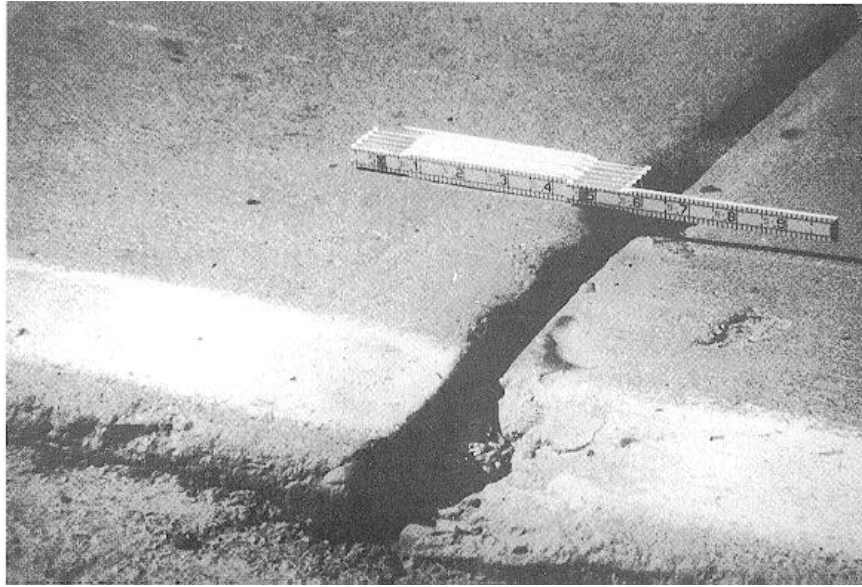


Figure 4-9. Faulting.



Figure 4-10. Joint seal damage, incompressibles in joint.

causes for transverse cracking including: traffic, excessive joint spacing, and improperly cut contraction joints. Overloading and upward curl of slab edges combined with pumping are also possible causes. Diagonal cracking occurs at some angle other than 90 degrees from the longitudinal joint for many of the same reasons provided for transverse cracking.

i. *Large patch and utility cuts.* These patches include those which have a surface area greater than 5 square feet (fig 4-13).

A large patch is an area where the original pavement has been removed and replaced with a suitable filler material. The patches are usually constructed of concrete, but may also be constructed of asphalt and epoxy. A utility cut is made to allow the installation of underground utilities. The causes of distress of these patches are the same as for any pavement; however, the most frequent problem is poor compaction when filling the cut area. Where a patch was made for a pavement



Figure 4-11. Lane/shoulder dropoff.



Figure 4-12. Liner cracking.

distress, if the distress was not corrected, the patch will fail as the original pavement before it.

*j. Small patching.* Small patches are those less than 5 square feet in area (fig 4-14). As with a large patch, the area where the original pavement have been removed in small patches is replaced with a filler material.

*k. Polished aggregate.* Polished aggregate is caused by repeated applications of traffic (fig 4-15).

This distress occurs when the surface aggregate is smooth to the touch and when close examination reveals that the aggregate extending above the concrete is negligible. The traction between the vehicle tires and the pavement is considerably reduced by polished aggregate.

*l. Popouts.* The Mississippi watershed and especially the Ohio River Valley have problems with soft porous chert in the natural gravel normally obtained from streambeds (fig 4-16). These materials are potentially reactive with alkalis in cement and



Figure 4-13. Utility cut patch.



Figure 4-14. Small patch.

are susceptible to the phenomenon known as "popouts." The cause of popouts is physical (absorption of water and freezing), chemical (alkali reactivity), or a combination of both. The aggregate will expand and fracture, leaving a hole in the surface of the pavement which may or may not require maintenance.

m. *Pumping* Pavement pumping (fig 4-17) is the forceful ejection of water by deflection of a pavement slab. This usually carries subgrade particles in suspension from beneath the slab and up through cracks, joints, and along pavement edges.

It is caused by an unfavorable combination of free water and subgrade material susceptible to pumping and continuous use by traffic. The slab is forced downward under wheel loads, compressing any free water between the slab and subgrade which forces the water and soil out through cracks and joints. Repetition of this pumping action displaces subgrade soil and results in voids and cavities beneath the



Figure 4-15. Polished aggregate.



Figure 4-16. Popouts.

slab which leave the slab unsupported and subject to cracking. Nonplastic soils such as sands and gravels are practically free from pumping because the soil grains are larger and less susceptible to movement as the water is forced out. Good surface drainage, subdrains, and sealed joints reduce the probability of free water accumulating and contributing to pumping action. During initial construction, provision of a granular base or filter course immediately under the concrete will eliminate or minimize the probability of pumping.

The use of stabilized layers (asphalt, cement) underneath the PCC will also minimize the occurrence of pumping.

*n. Punch out.* A punch out is a localized area of slab that is broken into pieces (fig 4-18). This distress is usually defined by a crack and a joint or two closely spaced cracks (usually 5 feet wide). It is caused by heavy repeated loads, inadequate slab thickness, loss of foundation support, and/or local



Figure 4-17. Pumping.



Figure 4-18. Punch out.

ized concrete construction deficiency (e.g. honeycombing).

*o. Railroad crossing.* Railroad crossing distress is characterized by depressions or bumps around the tracks (fig 4-19). This distress is usually a construction defect which causes an uneven surface of low ride quality. When distress is not related to the original construction, it may fit into one of the other categories given in this section.

*p. Scaling.* Scaling (fig 4-20) is the progressive disintegration and loss of the concrete wearing surface. The major causes of scaling are the physical and chemical reactions of deicing materials in the presence of repetitive freeze-thaw or wet-dry cycles, a weakened surface created by improper mixing, improper curing or overfinishing, and the use of unsuitable aggregates in the mix. Scaling most commonly occurs at locations heavily treated with deicing



Figure 4-19. Railroad crossing.



Figure 4-20. Scaling.

ing chemical such as on hills, curves, bridge decks, or near intersections. Scaling is seldom seen in high quality mixture where severe frost action does not occur. Scaling may be reduced to a minimum by entraining 4 to 7 percent air in the concrete mix.

*g. Cracking.* Cracking (fig 4-21) refers to a network of shallow, fine, or hairline cracks which apparently extend only into the upper surface of the concrete. These cracks tend to intersect at an angle of approximately 120 degrees forming a pattern similar to chicken wire. Cracking usually results from a rapid loss of moisture at the surface through evaporation during

the early curing period causing excessive shrinkage of the surface mortar. The condition can be aggravated by excessive finishing which brings moisture to the surface. Almost all concrete has some surface crazing; however, severe crazing can lead to scaling or other surface deterioration associated with weathering.

*r. Shrinkage cracks.* Cracks often result from stresses caused by contraction or warping of the pavement (fig 4-22). Poor jointing arrangements and/or inadequate curing help generate excessive contraction movement prior to attainment of design strength of new concrete.



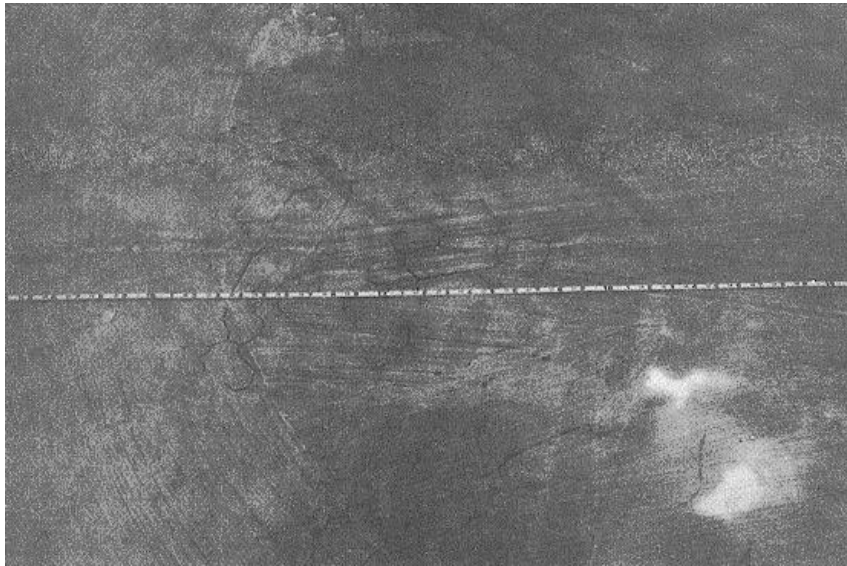


Figure 4-21. Crazing.



Figure 4-22. Shrinkage crack.

s. *Corner spalling.* Corner spalling (fig 4-23) is characterized by cracking and breaking or chipping of the pavement at the corner of the slab. This breakdown of pavement usually occurs within 2 feet of the corner. The primary cause of spalling is inferior concrete or excessive stress concentration at the joint or crack. The stress concentration may result from several different factors. Major causes include hard pieces of gravel or other debris lodged in a joint or crack, improper forming or sawing of joints, and improper installation of load

transfer devices. Inferior concrete at a joint may cause spalling under normal loading as will insufficient pavement thickness. If the thickness is not adequate, excessive deflections under traffic will occur at the corner resulting in spalling or raveling of the concrete. Dowels used as load-transfer devices across expansion joints may cause spalling when not placed perpendicular to the expansion joint and parallel to the surface of the pavement.



Figure 4-23. Corner spalling.

*t. Joint spalling.* Joint spalling (fig 4-24) is characterized by cracking and breaking or chipping of the pavement along joints, edges, or cracks. The primary cause of spalling is inferior concrete or excessive stress concentration at the joint or crack. The stress concentration may result from several different factors. Major causes include hard pieces of gravel or other debris lodged in a joint or crack, improper forming or sawing of joints, incorrect type or improperly installed load-transfer devices and rusted "frozen" sliding dowels. Inferior concrete at a joint may cause spalling under normal loading as will insufficient pavement thickness. If the thickness is not adequate, excessive deflections under traffic will occur at joints and cracks resulting in spalling or raveling of the concrete. Dowels used as load-transfer devices across expansion joints may cause spalling when not placed perpendicular to the expansion joint and parallel to the surface of the pavement. Improperly formed joints may also cause spalling.

*u. Pavement conducive to hydroplaning.* Hydroplaning occurs when a tire loses direct contact with the pavement surface and rides on a film of water. This condition can occur at various speeds depending on the tire pressure, type of tread, and the condition of the pavement surface. When there is a sound concrete surface present, grooving of the concrete may be used to reduce hydroplaning. An AC overlay may be used to restore the pavement surface to an acceptable performance level. When rubber buildup becomes a problem, it can be removed to restore the pavement to an acceptable service level.

#### 4-5. Concrete pavement materials

The basic materials used in concrete pavement include the aggregates and cement binder. These and other materials used in maintenance and repair are given in the following paragraphs.

*a. Aggregates.* The requirements for aggregates used in PCC are given in paragraph 4-2c(3). The aggregates used for epoxy concretes will be clean, washed, dry gravel or crushed stone, Y8- or V2-inch maximum size, well graded from coarse to fine, and of the same quality used for PCC. It is desirable that the material passing the No. 100 sieve be held to a minimum. The permissible maximum size selected will depend on the intended use of the material. In general, for both epoxy concrete and mortar, the maximum size aggregate will not exceed one-fourth the thickness of the layer being placed or one-fourth the width of the opening being filled.

*b. Cement.* See paragraph 4-2c(1)(a) for cement requirements. The type of cement selected will depend on local conditions and job requirements. It may be desirable in some cases to get the repaired area back into service with a minimum of delay. In this case, the high-early-strength Type III cements are recommended. Special regulated-set cements, which have the capability of providing very high strength concrete in less than 1/2 hour after mixing, can be used; however, under most conditions the excess cost over Type III cements makes their use prohibitive. Also, the need for such rapid early strength is seldom required in normal installation maintenance operations. Concrete containing high-alumina cement is not recommended due to its in

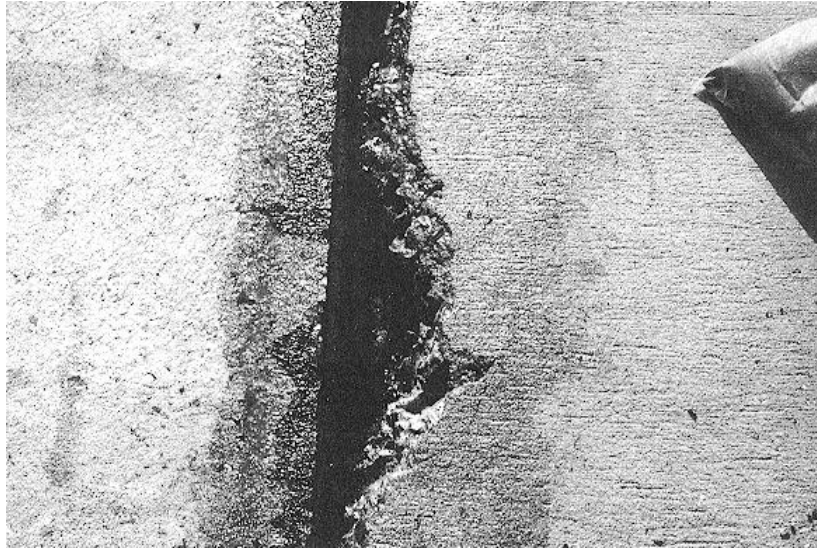


Figure 4-24. Joint spalling.

stability at temperatures only slightly above normal room temperature when moisture is present. Under these conditions the product exhibits about a 50 percent strength loss. The Type III cements, which are high-early-strength, are recommended for use in repair of bridge decks or other similar areas where it is necessary for traffic to be on the roadway as soon as possible.

c. *Sealants.* Most of the sealing compounds are of the pourable type; i.e., they are liquids during application and become solid either by cooling or by physical or chemical reactions. Sealants which solidify upon cooling are referred to as "hotpoured." Sealants which solidify by loss of liquefying agent or by chemical reactions are described as "cold applied." Both types are further divided into two groups identified as non-jet-fuel resistant sealers and jet-fuel resistant (JFR) sealers used on airfield pavements where fuel, lubricant, and solvent spillage occur. Cold-applied JFR sealers are also classified as blast resistant.

(1) *Performed sealer.* Another type of joint sealer is the preformed sealer. Preformed sealers have been made for bituminous-impregnated foam rubber (usually polyurethane), cork, and extruded neoprene. The neoprene seal, often referred to as a compression seal, has been used in new construction on highway pavements and airfield pavements. An ASTM Specification has been used for purchasing purposes. The use of compression seals in maintenance or repair work has been minimal.

(2) *Hot-applied sealants.* These are sealants which must be heated prior to application.

(a) *Non-fuel resistant.* Rubberized-asphalt sealant (non-fuel resistant) is the most widely used of all hot-applied crack and joint-sealing materials on highways, city streets, and airfields. The sealant is

made by dispersing rubber in an asphalt cement of suitable grade. Rubbers have varied from new high-quality reclaimed rubber to low-quality waste, such as buffings from tire-retreading operations. Federal Specifications SS-S-1401C applies to hot-applied non-fuel resistant sealants for concrete and asphalt pavements.

(b) *Fuel resistant.* Sealants consisting of a coal tar base with either rubber or polyvinyl chloride additives have been developed for use on airfield pavements subjected to spillage of fuels, lubricants, and solvents. Locations where spillage occurs are parking aprons and maintenance and refueling areas. Asphalt-base sealants are unsuitable in these areas because the spilled materials are petroleum derivatives and have a solvent action on asphalts, which are also derived from petroleum. Tars, which are only slightly affected by fuel spillage, are produced from coal and have a different chemical makeup than asphalt. Federal Specification SS-S-1614A applied to hot-applied fuel-resistant sealants for concrete pavements.

(3) *Cold-applied sealants.* Sealants which can be applied at ambient temperatures.

(a) *Non-fuel resistant.* Silicone type sealants are most widely used. These sealants are normally applied by extrusion methods and require tooling or smoothing out (not normally self-leveling). Emulsion sealants, although the least expensive, are becoming less popular because of low durability.

(b) *Fuel resistant.* Federal specification SS-S-200E applies to two-component, polymer type cold-applied sealants. These sealants are intended for pavements subjected to spillage of fuels and lubricants and to jet blast. These polymer-type sealants are composed of tar and usually polysulfide or polyurethane-based in liquid form. These materials make-up the two components (accelerator or hardener and base or resin) which are combined to form the sealer.

d. *Epoxy.* Repairs with epoxy materials are costly, and their use which is limited to small areas and application should be by experienced personnel. The repair of spalls on concrete pavement can be accomplished using epoxy resin grouts, mortars, and concretes. Special handling procedures are necessary when using epoxies. There are many types of epoxy resins. The type to be used depends on the application being considered. Under normal conditions, when all precautions are observed, mixed resins may be workable up to 1 hour after mixing. Most epoxy resins are sensitive to water. Water mixed with the epoxy will materially affect the resin reaction and alter the properties of the cured system, if it does not completely prevent the cure. There are systems that are relatively insensitive to water. These are recommended for applications for bonding plastic concrete to hardened concrete. However, even with these systems, the amount of water present must be controlled, and the maximum slump of plastic concrete should be 2 inches or less. A number of specifications have been published for epoxy resins to be used in construction, including ASTM C-881. Epoxy mortars or concretes may be machine- or hand-mixed after the epoxy components have been mixed. Small drum-type mechanical mixers have been used successfully but are difficult to clean properly. Large commercial dough or masonry mortar-type mixers have been widely and successfully used. The epoxy resin material is initially placed in the mixer, the fine aggregate is then added, and then the coarse aggregate is added. This procedure permits proper coating of the fine aggregate particles. Epoxy mortars have short cure times and, except in cold weather, traffic may be permitted on the pavements 4 to 6 hours after repairs. This high strength gain is one of the most favorable features of epoxy repairs, and successful repairs can be made where construction procedures are carefully followed. However, use of epoxy concrete is not normally recommended because of the expense involved and some differences in its expansion properties and those of the adjacent sections. Full details of patching procedures using epoxies are described in TM 5-822-9 and Naval Facilities Engineering Command Instructions 11014.24B.

e. *Bituminous material.* See chapter 3 for the requirements for bituminous materials.

The equipment listed in this section for each type of repair covers only the specialized equipment normally used for that type of repair. The equipment commonly used in most types of repairs is listed below. Auxiliary and/or alternate equipment not mentioned may be used provided it fulfills the requirements to successfully complete the job.

a. *Cleaning equipment.* Cleaning equipment includes all the brooms or sweepers necessary for removing excess material. Compressed water and air are often used in cleaning areas to be repaired. For crack and joint repair, it is desirable to have a vacuum pickup sweeper of sufficient size at the worksite to pick up plowed joint materials and debris from cleaning and refacing operations. Such a sweeper will remove old joint sealer from the pavement surface as it is plowed out, thereby preventing these materials from getting back into the joints or being pressed into the pavement surface by other vehicles or equipment used in the work.

b. *Miscellaneous hand tools.* Miscellaneous hand tools include tools such as picks, shovels, hammers, and other assorted tools.

c. *Power saws.* A self-propelled power saw with water-cooled diamond or abrasive saw blades (fig 4-25) should be provided for cutting joints to the widths and depths specified or for refacing joints where surface films of oil sealants cannot be readily removed by sandblasting.

d. *Pneumatic drill unit.* A pneumatic drill rig with assorted drill bits and other necessary equipment is utilized in various ways such as drilling holes for dowel bars and in slab jacking.

e. *Water tank truck.* A water tank truck is necessary in remote areas (water not directly accessible) where water is required. Although gravity feed may usually be adequate, a pump for water discharge should be included. When cleaning out cracks and joints, an adequate pumping system for high pressure water is advisable (fig 4-26).

f. *Air compressor unit.* Any air compressor capable of supplying sufficient air for the operation of pneumatic drills, jackhammers, or for blowing out mud and water from cracks and joints is required. A compressor capable of maintaining a line pressure of 90 pounds per square inch at the nozzle is the minimum size suggested for cleaning cracks and joints (fig 4-27). The compressor will be in good operating condition and equipped with traps that will maintain the compressed air system free of oil and water.

#### 4-6. Concrete pavement equipment

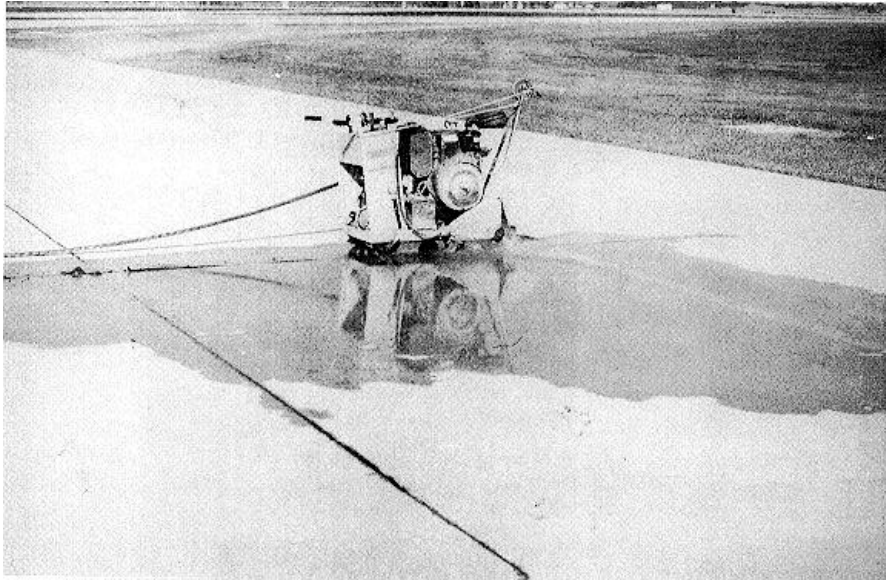


Figure 4-25. Water-cooled power saw.



Figure 4-26. High-pressure water hose.

*g. Jackhammers.* The jackhammers used shall be of sufficient size and supplied with all necessary bits. Edges of concrete to remain shall be protected and not used as lever points during jack hammering.

*h. Trucks.* The term trucks covers every vehicle from pickups to dump trucks. The number and type required depend on the work to be accomplished.

*i. Patching.* The equipment listed is for repairing with PCC. See paragraph 3-5 for equipment required for an asphalt patch.

(1) *Finishing equipment.* Finishing equipment shall include floats, drags, brooms, or anything necessary to get the required finish.

(2) *Front-end loaders.* Front-end loaders are very versatile and are used for moving materials



Figure 4-27. Blowing out dirt from joints.

and placement. The size required will depend upon its intended use.

(3) *Grad-all or suitable pavement remover.* This equipment is used to remove broken slabs and/or large sections of pavement to be repaired.

*j. Crack and joint sealing.* The following paragraphs detail the equipment used to seal cracks and joints.

(1) *Joint plows.* Dummy groove joints, expansion joints, and construction joints can be cleaned with a specially made tool attached to a farm tractor (fig 4-28). The cutting tool will be equipped with a properly adjusted spring or hydraulic holding device. Contact with any wedged foreign object, irregular joint wall surface, nonalignment, or joint at intersections will release pressure on the cutting tool prior to causing concrete damage along the joint edges. V-shaped tools or rotary impact routing devices will not be used as damage to the sides of the joint may occur.

(2) *Powered routers.* Cracks and joints containing material to be removed are normally plowed first to remove the bulk of the material. The remaining material not removed by plowing may be removed by waterblast, sandblast, or saw cutting. The router should be designed for removing residue of material from the joints and for refacing the joints to provide a clean, vertical concrete face. The power cutter should be a self-powered machine operating a vertical spindle revolving cutting tool (fig 4-29). The vertical impact router (fig 4-30) has been used; however, it will tend to leave rounded or spalled joint edges. A power-driven rotary routing tool with a V-shaped end (similar to a high-speed drill) works best for cleaning random cracks.

(3) *Power brush.* A power-driven wire brush may be used after plowing when necessary to clean

joints and cracks. The brushing will avoid further widening or injury to sidewalls. However, it can only be used if the new sealant is compatible with the old sealant. Two precautions on the use of wire brushes are that they spread and burn-in any residual sealant, and they lay down their own metallic luster on the concrete. Sand blasting is usually required after using a brush. Wire brushes are considered a detriment except as stated above.

(4) *Sand blasting.* Sand blasting equipment is the most reliable method for final removal of joint materials and for removal of curing membrane and debris from sawed or formed joints in concrete replacement areas. The nozzles used for sand blasting must have a diameter smaller than the width of the joint and be equipped with an adjustable guide that will hold the nozzles aligned with the joint about 1 inch above the pavement surface (fig 4-31). The height, size of nozzle, and angle of inclination will be adjusted to secure the results desired. Adjacent aircraft, vehicles, and people must be protected.

(5) *Water blasting.* Water blasting with high-pressure water jet equipment should include trailer-mounted water tank, pumps, high-pressure hose, wands with safety release cutoff controls, nozzles, and auxiliary water resupply equipment. The water tank and auxiliary resupply equipment should be of sufficient capacity to permit continuous operations. Pumps, hoses, wands, and nozzles should be of such design, and operate at such water pressure and rate of discharge to clean the bottom

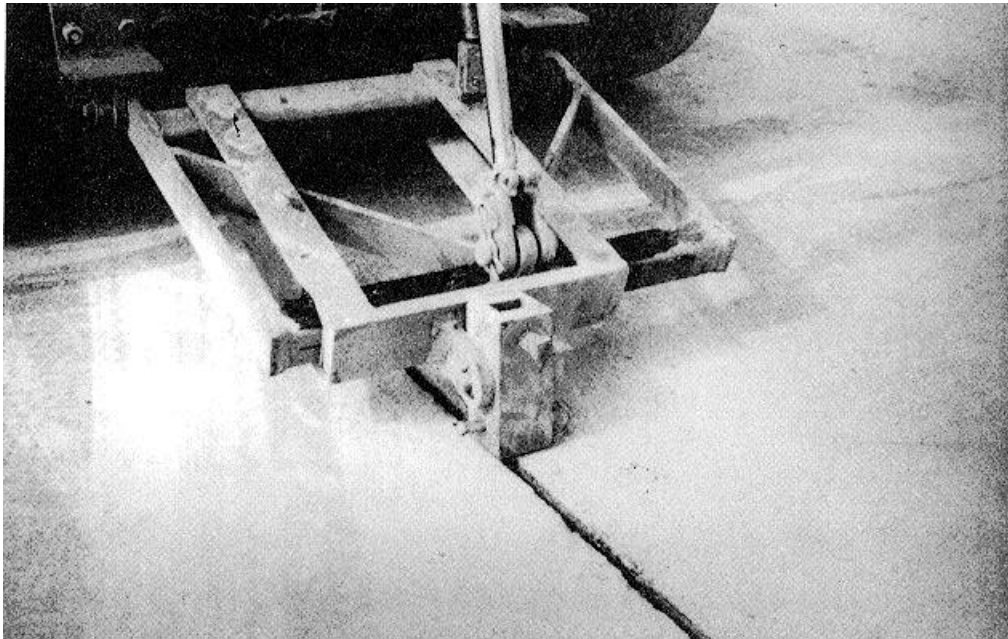


Figure 4-28. Joint plow.



Figure 4-29. Vertical router spindle.

and both walls of the joint. They should also be able to clean the pavement surface on both sides of the joint for a width of at least  $\frac{1}{2}$  inch. A pressure gage should be mounted at the pump which will show at all times the pressure in pounds per square inch at which the equipment is operating. Waterblasting may not be suitable where base course material cannot sustain

localized saturation or where displacement of the base course material would occur.

(6) *Compressed air.* Compressed air should be used last, after any or all of the previously cleaning methods and just before sealant application. The requirements for compressed air equipment are similar to those of waterblasting.

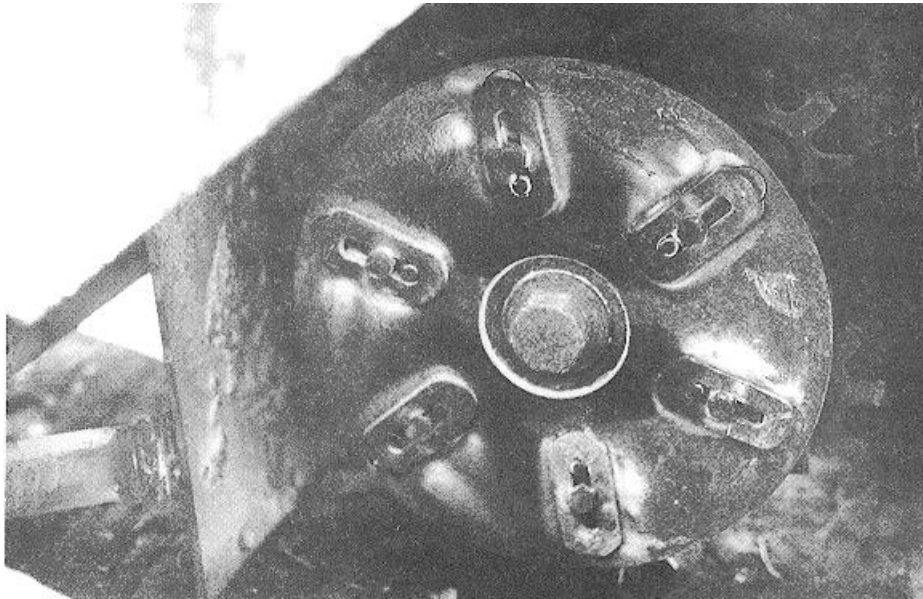


Figure 4-30. Vertical impact routing device.

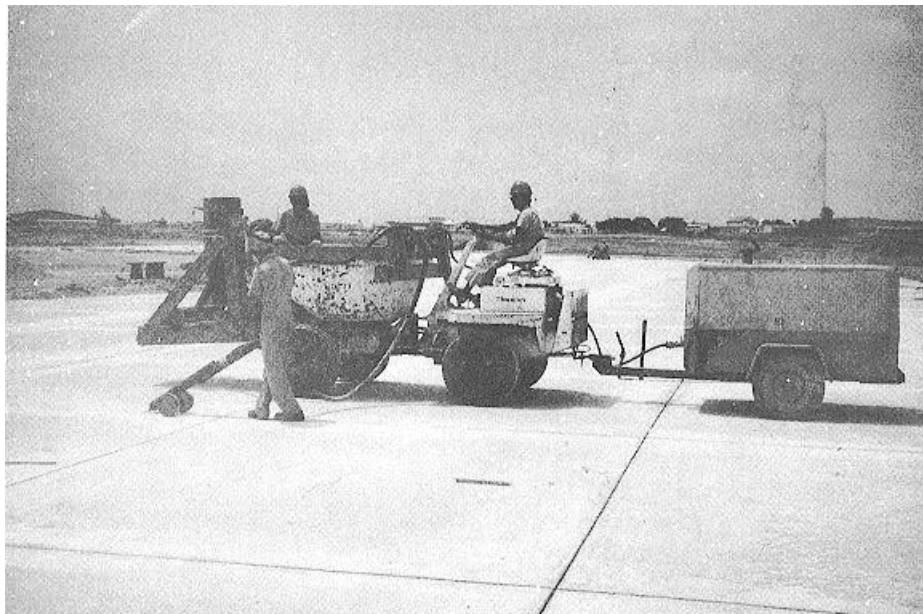


Figure 4-31. Sand blasting joints.

(7) *Portable melting units.* These portable melting units are usually double-boiler-type melters and use an indirect heating method. They use a heat-transfer oil between the inner kettle and outer jacket; the oil is the medium which transfers the heat from the flame to the sealer material. The unit must have a method of agitating and recirculating the material and be able to obtain temperatures ranging from 200 to 300 degrees F.

(8) *Pouring pots.* Pouring pots are hand held pots which can be used to pour heated sealers into cracks (fig 4-32). This method should not be utilized except on small cracks less than 1/8 inch wide or in areas inaccessible to other types of equipment.

(9) *Joint material applicators.* One type of applicator uses a pressure base attached directly to a



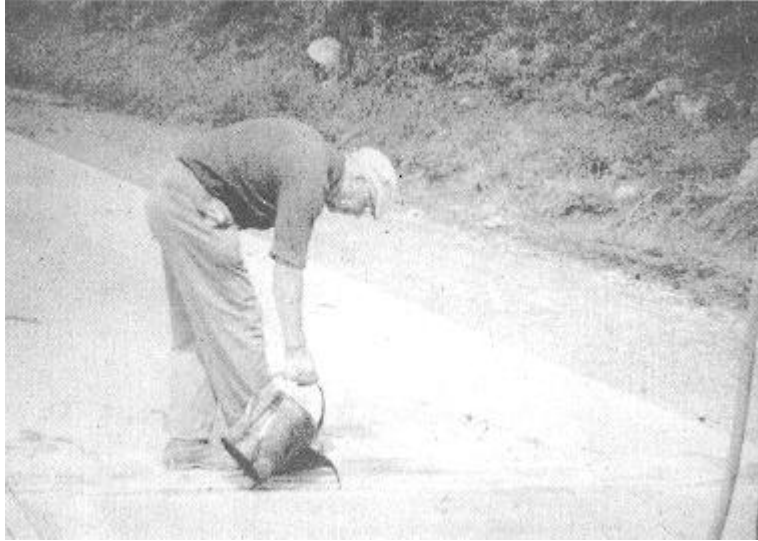


Figure 4-32. Applying crack sealer with a pouring pot.

pump unit on the melting kettle in a manner which permits pumping the sealer through the base to a suitable applicator (fig 4-33). Another method is where the sealer is forced by gravity into the joints from the applicator. In the last method a self contained insulated pressure unit is used to apply the sealant.

k. *Slab jacking.* The following paragraphs describe the equipment used in slabjacking

(1) *Concrete or pugmill-type mortar mixer.* The mixer unit must be capable of producing a quantity of mix to be compatible with the jacking unit used.

(2) *Hydraulic jacking unit.* A hydraulic jacking unit of the positive-displacement type capable of instantaneous control of grout pressure is required.

(3) *Concrete buggy.* A concrete buggy is required to transport the grout from the mixer to the jacking unit.

(4) *Plugs.* Hardwood plugs with a slight taper are required for each hole drilled.

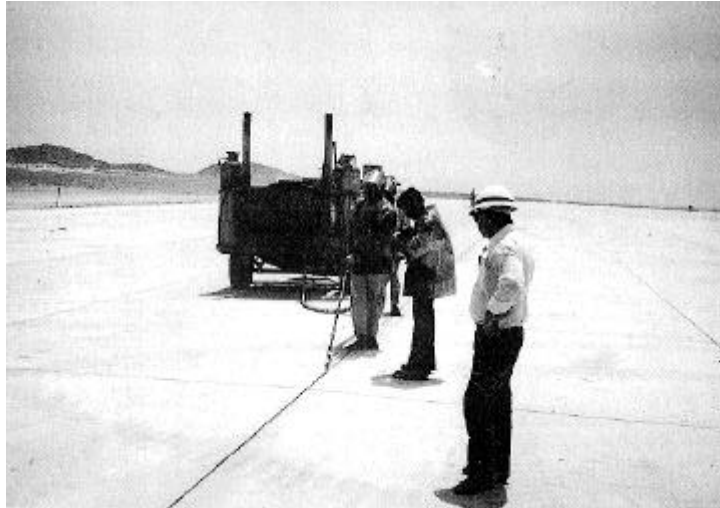
1. *Bituminous undersealing.* The asphalt tank will be equipped with a method of circulating the asphalt and utilizing indirect heat for the asphalt. The pump attached to the heating tank will be a bituminous pressure type equipped with flexible metal hose and a tapered nozzle which can be inserted into the drilled holes for more efficient penetration. A nozzle equipped with three-way valve and double hose permitting circulation of hot asphalt is preferable. Hardwood plugs with a slight taper are required for each hole drilled.

#### 4-7. Methods of concrete maintenance and repair

The objective of maintenance is to keep the concrete pavement in a satisfactory condition. Prompt and adequate maintenance greatly extends the useful life of a pavement. Maximum benefits will be obtained when seasonal maintenance operations such as sealing cracks and joints and patching are performed at the proper time and according to accepted practices.

a. *Concrete patches.* Concrete is most desirable for patching deterioration in rigid pavements because it preserves uniformity of appearance and provides a strong durable repair. Concrete patches consist of partial-depth patches and full-depth patches.

(1) *Partial-depth patches.* Partial-depth patches involve removing the concrete from the surface down to sound concrete. For this type of patch, the edges will be squared and the sides cut vertical using a concrete saw or air hammer. Where there is distress at a joint due to spalling or any other cause where a partial-depth patch is required, the following procedure for removal and repair is recommended. Using a power saw a vertical cut should be made a minimum of 12 inches deep and approximately 2 inches back of the distressed area for the entire length of the damaged section. Cuts should be made at corners and along the edges of the patch so that a square or rectangular patch with vertical sides is obtained (fig 4-34). After making cuts with



*Figure 4-33. Applying joint material.*



*Figure 4-34. Prepared partial-depth patch.*

the power saw, the unsound concrete between the saw cut and the joint to be repaired should be broken out with pneumatic drills and hammers. Compressed air should be used to blow off the residual dust from sawing, chipping, or drilling operations. The area should be thoroughly pressure rinsed after all the unsound concrete has been removed and the fines blown off. Thoroughly scrub any oil-soaked

areas with a suitable detergent. The use of muriatic acid for cleaning the surface, especially for epoxy repairs, is not recommended. This process is sometimes used to assure that sound, clean concrete is exposed over the entire area to be repaired. The muriatic acid etching process can normally be eliminated by using mechanical abrasion to expose sound, clean concrete. The surface should be treated

with a bonding grout mixture to ensure a tight contact between the existing pavement and the freshly repaired concrete. The grout or bonding mortar will be composed of one part Portland cement to one part fine sand and will not contain more than 5 gallons of water per sack of cement. The mortar will be mixed to a thick, creamy mixture in an approved mechanized mixer. The bonding grout should be applied immediately preceding the concrete patch mixture and spread over the entire surface with a stiff broom or brush to a depth of 1/16 inch. Place a thin strip of wood, asphalt impregnated fiberboard or metal coated with bond-breaking material or lined with plastic in the joint groove, and tamp the new mix onto the old surface and against the form. Care will be taken in placing the filler board or joint cap so that it is aligned with the existing joint. One should ensure that the mixture used for joint repairs is an air-entrained concrete of high-quality materials. The proportions of cement and aggregate to be used in the mix can be determined by batch design tests. The maximum size of the coarse aggregates will be governed by the depth of the patches to be placed. The coarse aggregate will not contain particles larger than one-third the depth of the patch. Generally, the mixture will have a sand to aggregate ratio between 0.40 and 0.50 by weight. The mix will be designed to produce a "dry" no-slump concrete which will require tamping or vibrating to place in the patch. The patching material should be mixed in an approved rotary drum or pugmill-type mixer. For small quantities of patch

mixture, hand-mixing methods may be employed. Mixing must produce a homogeneous, nonsegregated mixture. After the bonding grout has been brushed into the surface of the area to be repaired, the concrete patching mixture should be placed within 10 minutes and before grout has begun to dry. Tamping or vibrating the mixture to ensure consolidation and positive bonding with the existing concrete is required. Mixture not placed within 30 minutes should be discarded, and a new batch must be prepared. When the finishing and edging have been completed, the patch will be broom finished to a texture matching the adjacent areas. When concrete has attained its initial set, the filler board will be removed and the joint cleaned with a hook or similar device. This procedure is necessary to ensure that no damage to the patched area will result from excessive stresses during expansion of the concrete. All patched areas will be cured by a covering of wet burlap or curing membrane for a minimum 3-day period after which the open joints will be filled with joint material prior to permitting use by traffic. A complete joint repair is shown in figure 4-35.

(2) *Full-depth patches.* For full-depth patches, the concrete will be sawed out approximately 6 inches outside of each end of the broken section and removed down to the base material. When patching near joints or on edges (fig 4-36), the concrete will be placed about 2 inches thicker than the adjacent pavement, and the patching material will extend about 2 inches under the in-place concrete. If the

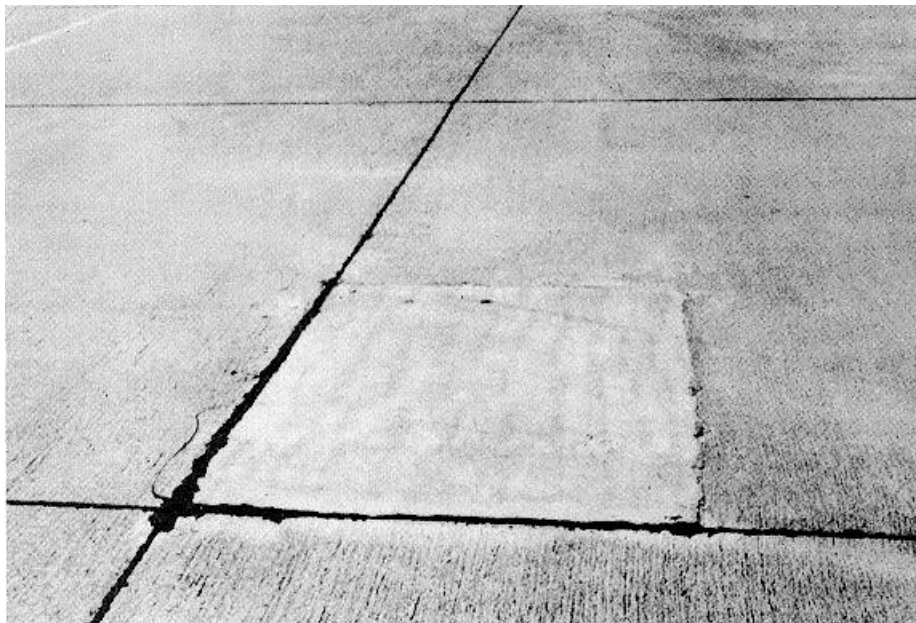


Figure 4-35. Completed patch.

distress is at a working joint, the patch must not impede movement of the joint. Bond-breaking systems such as polyethylene sheeting or grease should be used. If distress is located at transverse joints, a plastic or fiber joint material should be placed at the joint prior to filling the cavity where required dowel bars and other reinforcement will be placed as required (fig 4-37). The thickness of concrete at all patches will be as thick as the existing slab. For utility trenches, new patches will be a minimum of 4 inches thick but not less than 2 inches thicker than the existing slab.

(3) *Concrete mix.* Ready-mixed concrete should be used if it is satisfactory and can be obtained economically. For repairing runways or taxiways, it is desirable to use a mixture providing high-early

strength, thereby permitting the earliest possible use. For small patching jobs, concrete in small ¼- to ½-bag mixes is acceptable. Material proportions for small batches are indicated in paragraph 4-2c(6). To obtain more uniform mixes, all batching will be done by weight. Batches will be mixed for a minimum period of 1 minute to secure a homogeneous mix. Only high-quality materials will be used for concrete repairs. Materials will be properly proportioned and a minimum amount of water used for mixing. Air-entrained concrete will be used for all patching and repairs.

(4) *Placing concrete.* Prior to the placement of new concrete patches, edges of adjacent slabs and the cavity for shallow patches will be free from dust, loose concrete, dirt, or other foreign materials

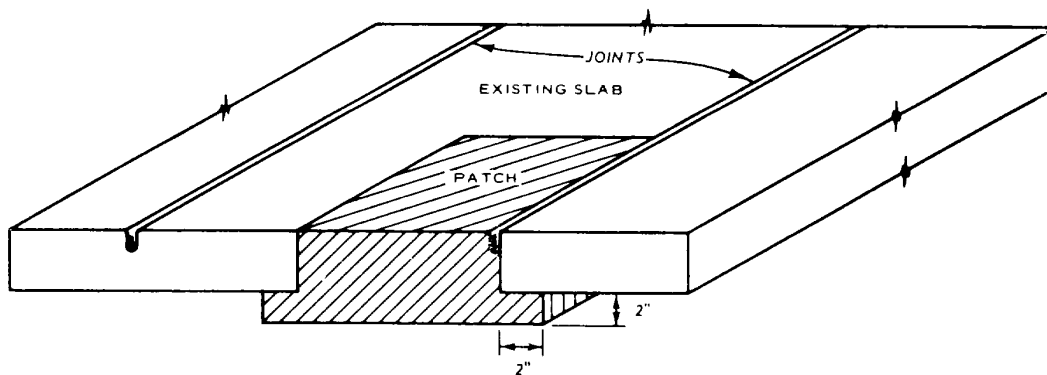


Figure 4-36. Patching near joint or pavement edge.

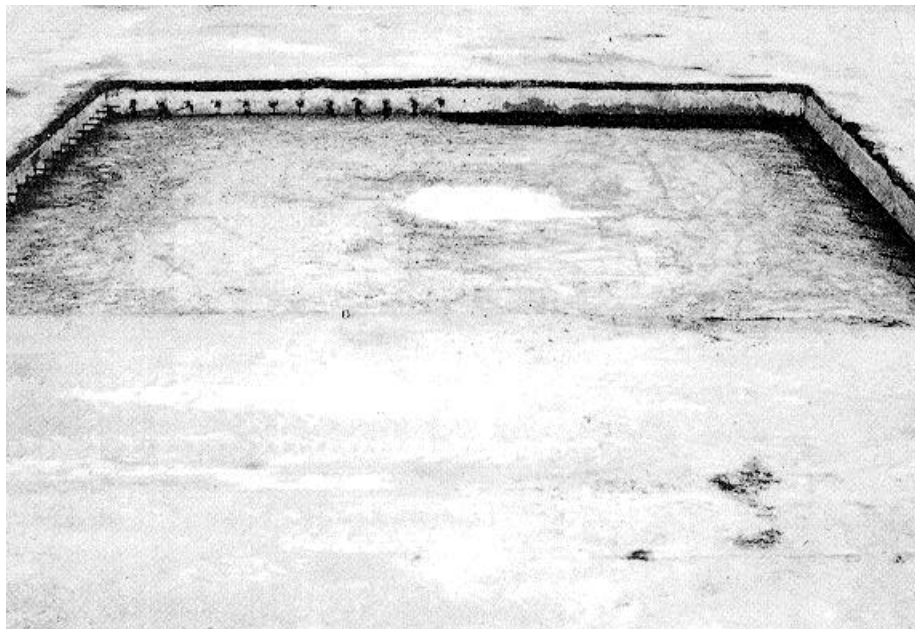


Figure 4-37. Full-depth patch with dowel bars at edges.

(fig 4-38). The cavity for the shallow patch must be primed with cement grout or epoxy grout, as appropriate. Vertical surfaces for deep patches must be moist with water, or the internal face should be primed with plain or epoxy grout. The subgrade or base material will be moistened to prevent the absorption of water from fresh concrete. If steel forms are used, the forms will be greased; new wood forms will be dampened with water. The joints will be set in place prior to placement of the concrete. In reinforced pavement construction, joint techniques are

used to tie the new concrete to the old reinforced material (fig 4-39) when constructing a patch. The replacement joint will be doweled and built to joint specifications. This may be an expansion joint with the traditional filler for expansion space, or it may be a contraction joint if expansion space already has been provided at some nearby location. The areas to be patched will be filled with concrete and tamped or vibrated and screeded off at a slightly higher level than the adjacent finished surface (fig 4-40). Mechanical vibrating equipment consolidates the



Figure 4-38. Cleaning patch area with compressed air.



Figure 4-39. Placing reinforcement and dowels in area to be repaired.

freshly placed concrete quickly and efficiently. If drier mixes are used, thorough tamping is absolutely essential to ensure consolidation, a minimum of voids, and elimination of honeycombing in the concrete. Tamping along the edges forces concrete firmly against the existing slab and helps to prevent separation caused by shrinkage during the curing period.

(5) *Finishing*. Surface texture of new patches will be approximate to that of existing pavement.

The concrete will be floated and the surface finished using canvas, rubber belting, burlap drags, or brooms (fig 4-41). New continuous joints, if necessary, will be constructed in the patch to match existing joints.

(6) *Curing*. Immediately after completion of finishing operations, the new surface will be covered and kept damp for a period of several days, or membrane curing compound will be applied to prevent loss of moisture from the new concrete. A cur-



Figure 4-40. Placing concrete in patch area.



Figure 4-41. Finishing surface of concrete patch.-

ing technique will be applied as soon as the new patch surface is hard enough to resist marking. The area will be surrounded by a barricade and traffic barred from the area until concrete has attained sufficient strength to carry loads (approximately 3 days). Military Construction Guide Specification 02515 and AFM 91-23 provide guidance regarding methods for curing concrete.

*b. Bituminous patching.* See chapter 3 for procedures pertinent to the use of bituminous material. Broken concrete areas can be patched with bituminous mixes when conditions require repair. In some cases, the bituminous patch can be left in place if there is no objection to discoloration of the surface. Normal traffic may be permitted on bituminous patches immediately after completion of the patch. Hot bituminous patches allow traffic on the pavement immediately after completion; however, the life of these patches is relatively short in comparison to concrete patches.

*c. Slab replacement.* When normal maintenance procedures can no longer adequately prevent or correct effects of ordinary pavement wear and use, repairs may become necessary to restore damaged areas to their original condition. Replacement is generally necessary when slabs have been broken or have deteriorated to such extent that safe support of the required loads is no longer possible. Repair work also may include pavement resurfacing.

(1) *Replacement of broken areas, blowups, and utility cuts.* Badly cracked, broken, or deteriorated pavement areas will be removed entirely and replaced with new concrete. Manual concrete removal will be considered only when mechanical methods are not practical or equipment is not available. Manual removal will be restricted to small areas. Heavy sledges may be used for breaking pavements, if necessary, but adequate precautions will be observed at all times. The use of mechanical equipment will greatly accelerate these operations and appreciably reduce the cost of repair. Such equipment includes portable air compressors, pneumatic pavement breakers complete with chisels and bits, and various small tools. Boundaries of the areas to be repaired will be outlined and cut using a concrete saw, if available, to a depth of 2 inches to ensure clean vertical edges for repairs. When cutting slabs for the purpose of making utility repairs or installations, the concrete will be cut back to about 9 inches beyond the limits of the trench, thereby providing adequate subgrade support of the new patched areas. Backfill trenches are required in original construction with materials having similar physical properties as the adjacent undisturbed materials and thoroughly compact to densities.

(2) *Subgrade.* Pavement breakage is usually

caused by undesirable conditions affecting the base and subgrade, e.g., frost, seepage, subgrade settlement, or overloading. Unstable subgrade materials will be removed to a minimum depth of 12 inches and replaced with selected nonplastic granular materials. The subgrade under replacement or repaired areas will be stabilized and compacted at optimum moisture content prior to replacement of the patch. Poor drainage will be corrected by the installation of adequate drains for the interception and removal of excess water. Utility trenches should be shaped in the subgrade so that adjacent materials are not disturbed. All materials will be compacted thoroughly in layers at optimum moisture content, thereby preventing future settlement. This is especially true with utility cut repairs.

*d. Crack and joint sealing.* Crack and joint sealing is used to prevent damage to the pavement structure from water passing through the pavement and into the underlying layers. Sealing will prevent the accumulation of foreign matter in cracks and joints. Sealing will also protect expansion joint materials which tend to deteriorate and become inert if not protected.

(1) *General.* To make the concrete slabs crack in neat straight lines, which simplifies maintenance, joints are placed at predetermined intervals. Contraction joints are formed either with preformed inserts or sawed to a minimum depth of  $\frac{1}{4}$  of its thickness, normally within 8 to 24 hours after concrete placement. Full-depth joints are junctions placed between slabs to permit expansion, to control cracking, or to meet construction requirements. Joints formed by inserts or sawing are used to induce cracking along with resulting weakened plane. Depending on the construction and function, joints can be classified as expansion, contraction, or construction joints. Another type of joint, the longitudinal construction or shoulder joint, is found between the concrete slab and the shoulder of the road. Expansion and contraction joints which are not functioning properly due to accumulation of foreign matter in the joint frequently cause spalling of the concrete at the joint and can be the cause of pavement blowups. A walking inspection of the pavement by competent personnel and close observation of the condition of the joints reveal the need for resealing. The person making such an inspection determines whether the existing joint seals are bonded to the adjacent concrete; whether the material has become oxidized and brittle; or whether, due to expansion and contraction, fine sands have formed a thin separation between the joint material and the sides of the joint. Cracks in the pavement should be sealed only if the crack is working and extends the full depth of the pavement. Much effort

and material are wasted, and unsightly conditions are created by attempts to seal narrow, tight, cracks. Procedures for determining sealing requirements and proper installation are outlined in TM 5-822-11/AFM 88-6, chapter 7.

(2) *Preparation of the joints and cracks.*

Joints and cracks must be thoroughly cleaned of old jointsealing materials, dirt, oil, and other foreign material to a depth of not less than 1 inch. Cracks that are working, spalled, or are at least  $\frac{1}{4}$  inch in width, will be cleaned by brooming and blowing with compressed air. All cracks, whether previously sealed or not, will be properly routed or sawed to a minimum depth of  $\frac{1}{4}$  inch and to the minimum width necessary to ensure clean surfaces on each side. This is difficult to obtain without excess injury and widening, unless the proper saws and vertical spindle routers are used. All joints and cracks will be thoroughly dry before application of sealing materials. Additional detailed information is available in AFR 88-35; AFM 91-23; TM 5-822-11/AFM 88-6, chapter 7. Methods of sealing joints and cracks vary according to size of areas involved. Use mechanical equipment to the maximum extent on board areas of pavement and use hand equipment only where necessary.

e. *Undersealing.* Undersealing is the term applied to bituminous material injected under pavements to fill and prevent minor voids caused by pumping action.

(1) *Undersealing materials.* Bituminous undersealing is mainly used to fill voids about  $\frac{1}{2}$  inch in depth. The use of asphalt to fill voids greater than 1 inch in depth or to raise slabs is not recommended. Only asphalt especially prepared for undersealing will be used. Recommended asphalt will have a penetration range of 15 to 30, a softening point range of 180 to 200 degrees F, be of suitable consistency for pumping when heated to a temperature of 400 to 500 degrees F, and be resistant to displacement in the pavement when cooled.

(2) *Procedure.* The method of placing bituminous undersealing is practically the same as that used for slabjacking using grout. The asphalt cement will be heated in the bituminous distributor tank to a temperature of between 400 and 500 degrees F. All water will be removed from beneath the slab with compressed air prior to pumping of the hot asphalt. The tapered nozzle on the asphalt hose will be driven tightly into the drilled hole and asphalt injected under pressure. The nozzle will be allowed to remain in a hole for approximately 1 minute after pumping ceases and pressure is reduced and then will be removed and the hole plugged. Pumping pressures will range from 20 to 40 pounds per square inch under normal conditions.

During pumping, water will be sprayed on the pavement adjacent to the drilled holes to prevent discoloration of the surface. Water saturated with hydrated lime is considered most suitable since spilled asphalt will then chill quickly and can be easily removed. Asphalt seeping up through cracks or joints can be quickly chilled and hardened by application of cold water.

f. *Slabjacking.* Slabjacking is used to raise the elevation of a slab or a portion of a slab. Slab elevation differentials create dips which are hazardous to traffic. This may cause breakage of slabs by impact loading of traffic.

(1) *Purpose of slabjacking.* The term "slabjacking" describes an operation known for many years as "mudjacking." Mud or soil-water mixtures are no longer used to jack pavements; finely ground limestone or sand and Portland cement mixtures are presently used. The purposes of slabjacking are simple. As grout is pumped under pressure through a hole cored in the pavement into the void under the pavement, it creates an upward pressure on the bottom of the slab in the area around the void. The upward pressure lessens as the distance from the grout hole increases. This is due to the viscosity of the grout and the skin friction created by the flow of the grout. Thus, it is possible to raise one corner of a slab without raising the entire slab. Joints in concrete pavements are pumping or expelling water and soil fines out of the joints or at edge of the pavement as traffic passes. A minor change of elevation in the existing pavement is necessary to realign surface of slabs to improve drainage characteristics. Slabjacking will not increase the design load carrying capacity of a concrete pavement and should never be considered with pavement strengthening projects except when there is a requirement to correct conditions listed above prior to placement of a strengthening overlay. Slabjacking is futile when the pavement is already badly cracked. AFM 91-23 provides guidance on slabjacking procedures.

(2) *Grout mixture.* A variety of grout mixes have been used successfully for slabjacking. They generally consist of three to seven parts fine sand or finely ground limestone and one part Portland cement with water added to produce the desired consistency. In areas where ground limestone is not readily available, hydrated lime has been used. A grout mixture of 20 percent cement and well-graded clean sand (30 percent or more fines passing the No. 200 sieve) can be easily pumped and will develop adequate strength. No pressure grouting operations will be performed when the ambient temperature is below 40 degrees F. Addition of calcium chloride (approximately 5 percent at 40-55 degrees F ambient



temperature and percentages ranging down to 1 percent at 99 degrees F and above) has been used successfully in grouting operations. Wetting agents and additives that increase flowability may also be used in the mix. A wetting agent lubricates the grout and permits runs up to 6 feet. Generally, a mix of stiff consistency is used for raising pavement slabs; a more fluid mix is used for filling voids. The proper consistency to be used for any given condition is best determined by experience.

(3) *Location of injection holes.* Slabjacking is an art, not a science, and should be carried out by competent, experienced crews. This is particularly true concerning the location of holes for injecting the grout. The operator must learn to space the holes according to the particular job and manner in which the slab must be raised or tilted. As a general rule, holes will not be placed closer than 18 inches from edges or joints. They will be located on not more than 6-foot centers so that not more than 25 to 30 square feet of slab is raised by pumping any one hole. Additional holes may be required if the slabs are cracked. The proper location of holes varies according to the defect to be corrected (fig 4-42). For pumping joints where faulting has not occurred, a minimum of two holes can be used. For a pumping joint with one corner of the slab faulted, the hole at the low corner should be set back to avoid raising the adjacent slab. Holes 1-14 to 1 inch in diameter will be drilled by a core drill or a pneumatic drill.

(4) *Slabjacking procedures.* Before work is started, some method of controlling the amount the slab is to be raised and the finished elevation of the pavement will be determined. For correcting faulted slabs, a straight edge may be used. For short dips up to 50 feet, a tight chalk line is adequate, providing the joints used are in a true plane with the adjacent pavement in each direction. For dips in excess of 50 feet, a precise level and rod will be used to check the profile well beyond the dip. This will avoid leaving a "bump" in the pavement. Leveling slabs at faulted joints or cracks is best performed during cool weather when the pavement is contracted and joints are open. For correcting a dip or

sag in the pavement, jacking will begin at the low point of the sag and progress longitudinally, staggering the holes transversely until the slab has been raised to desired elevation. All holes will then be pumped to make certain no voids remain under the slab. Slabs will not be raised more than 1/4 inch while pumping into any one hole at any one time. The entire slab and adjacent slabs will always be kept in the same plane within 1/4 inch to avoid cracking. When using two jacks, it is not desirable to work adjacent holes simultaneously. This may cause a line of stress that could crack the slab. In all slabjacking operations, the slab will be raised slowly with a uniform pressure. Care will be taken to ensure that an undesirable buildup of grout or "pyramiding" does not occur around the hole through which the grout is being pumped, or the slab may crack. When the primary purpose of the operation is to fill voids, pumping in one hole will continue until the grout begins to flow from adjacent holes. Adjacent holes may be temporarily sealed with wooden plugs which can be readily removed following the setting of the grout. When the nozzle is removed following the completion of slabjacking operations, all holes will be cleared and filled with a stiff 1- to 3-inch slump mortar mixture which will be tamped into place and floated to a smooth finish. Generally, a slabjacking crew consists of 6 to 10 men, a foreman, and at least one flagman.

*g. Slab grinding.* This method can be used where there is faulting between slabs or cracks within a slab. The procedure used is to grind the high side of the pavement down to the level of the other side. A more permanent solution is to use slabjacking or if the distress is severe, slab replacement.

*h. Grooving.* Grooving is used to improve the skid resistance of concrete pavements. Grooving is the construction of a series of small grooves or cuts in the pavement surface, usually 1/4 by 1/4 inch and spaced 1 1/4 inches apart. Grooving should be done in the transverse direction for airfields. Longitudinal grooves are used on roadways.

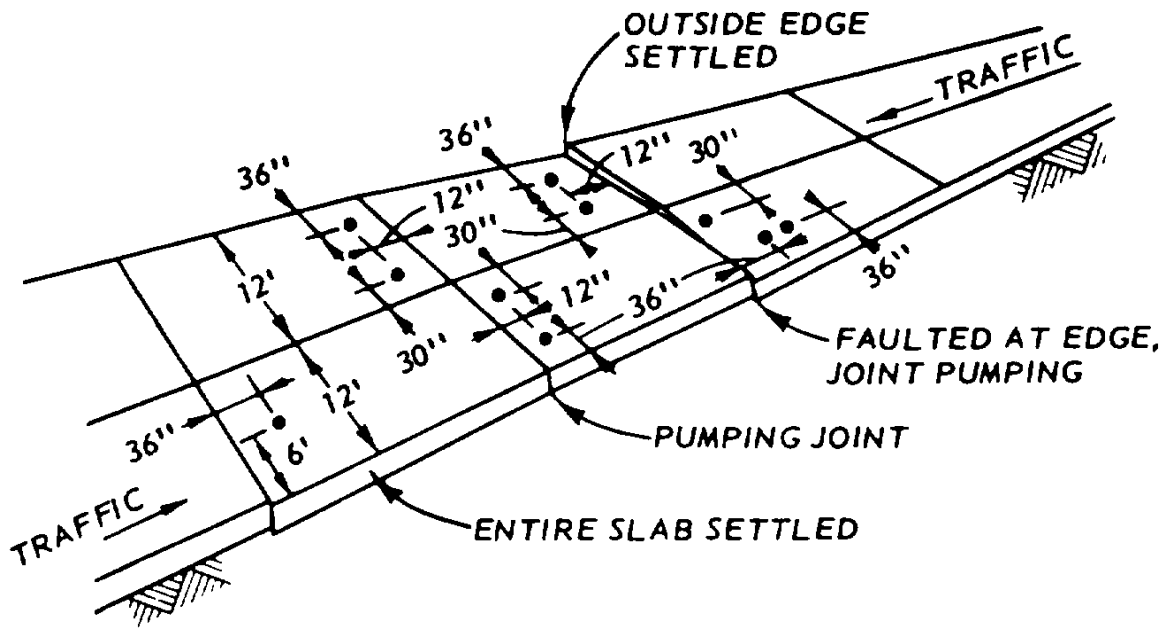


Figure 4-42. Proper location of holes depending on defect to be corrected.

## MISCELLANEOUS SURFACES

**5-1. Maintenance and repair**

This section covers maintenance and repair of various surfaces not specifically previously discussed. At military installations, light service roads to isolated facilities, range roads, patrol roads, emergency storage areas, areas under repair, stage construction, and stabilized airfield infield areas may be maintained as nonpaved surfaces. These surfaces may be untreated soil and aggregate (processed and unprocessed) or stabilized with chemical additives or by mechanical means. Methods for controlling dust on traffic areas are also discussed. Stabilized areas may have bituminous surfaces and seals that require maintenance in accordance with chapter 3.

*a. Surface defects.* Surface defects can usually be attributed to poor subbase or subgrade conditions, inadequate compaction strength of surface, erosion, inadequate drainage, or lack of routine maintenance operations. Overloading of a light traffic surface will also cause surface defects. An inspection for surface defects will include a careful investigation of the causes. Repair of these defects will be ineffective unless the cause is first corrected.

*b. Drainage inspection.* Drainage maintenance is particularly important in earth surface maintenance because the surface is generally not waterproofed, and the ground may be saturated and softened by water. If water is carried away promptly and surfaces are kept relatively dry, earth surface failures will be kept to a minimum. Those areas where runoff is slow or where water is ponded will be noted during the maintenance inspection following a heavy rain. These areas will be marked for prompt corrective measures. Earth surfaces will be graded regularly to maintain horizontal and vertical gradients and to keep cross-section crowns in an even and smooth condition.

**5-2. Types of Surfaces and Materials**

There are many types of surfaces and materials. Several types are discussed in this manual.

*a. Earth surfaces.* Earth surfaces include properly graded natural soil and may include occasional areas of other material such as gravel and crushed stone. Their anticipated life can be extended by proper maintenance. Three basic operations are involved in this maintenance: adequate repair and shaping to promote good drainage and a smooth surface, compaction as required to provide surface stability, and adequate dust control or replenishment of other surface treatments used to stabilize or seal the surface. The grading and shaping opera-

tions imply proper repair of potholes, ruts, and other surface irregularities. Earth surface maintenance involves blading to maintain adequate crown and roadway elevation so water drains rapidly and does not flow within the roadway. Blading should produce a smooth surface. Blading consists mainly of light scraping with a motorized blade grader or a drag. In remote areas where a motorized blade grader may not be readily available, consideration will be given to constructing multiple blade drags. They are normally pulled by a medium-size truck. Multiple bladed drags can be built of iron and heavy timbers and are useful for floating mud and water off a road surface. Blading will be done when moisture conditions are suitable for blading and compaction. Hand tools are necessary for work around manholes and other places inaccessible to machinery.

*b. Soil aggregate surfaces.* Untreated soils and aggregates used for low use surfaces and for flexible bases under pavements include a wide variety of natural and processed materials. All are generally similar in manner of use, flexibility, and methods of maintenance of repair. However, materials vary widely with respect to particle size, resistance to wear, and stability under wet or dry conditions. The more common types included in this category are gravel, crushed stone, slag, mine tailings, coral, shell, iron ore gravel, shale, caliche, disintegrated rock or granite, limerock, volcanic cinders, sand clay, and sand-clay gravel. In a given locality, the selection of types is usually limited to two or three of these materials or to combinations which are most economical.

(1) *Materials.* Soil-aggregate stability is provided by mechanical interlocking of particles and, to some extent, by the cementing action of fine soil particles developed by compaction. The particles of the material used for surface courses will be hard, in order to resist wear and crumbling when subjected to traffic. Maximum size of coarse particles should be limited to 1 to 1½ inches in the case of surface courses to ensure ease in working and to prevent raveling and displacement of aggregate by traffic. Shell, used only in coastal localities, needs a binder material to achieve compaction and will normally break down under heavy traffic. Limerock, caliche, shale, disintegrated granite, and similar types of materials will make a dense base course containing many fine particles. Compacted coral, limerock, iron ore gravel, and hard caliche develop stability from cementing action. Crushed stone develops stability from mechanical interlocking produced

by compaction. A good base material requires the complete drainage of all free water.

(2) *Gravel roads.* Maintenance procedures for gravel roads are the same as those for other earth surface roads. Continual shaping is needed to maintain a smooth riding surface and a uniform crown, and the drainage system will be kept functioning at full capacity. Gravel roads subject to heavy traffic require constant attention by maintenance patrols. Intensive maintenance is required when the surface is first opened to travel, since any irregularities that are compacted at this time will remain in the surface and can only be corrected by scarifying, reshaping, or adding more material and compacting. The surface should be bladed or dragged until all ruts and holes are filled; however, one should not work on a dry or saturated surface. A crown of not less than 1/2 inch per foot will be maintained. Graders will be used for both routine maintenance and for heavy reshaping work, and multiple blade drags or sled drags will be used for routine maintenance. A slight excess of gravel will be kept available at edges of the roadway and bladed uniformly over the surface in wet weather. Additional material may be stockpiled for use in fall and winter and during prolonged wet periods. Material added or spread on the surface during warm dry weather is of little value unless water is used during spreading and shaping.

(3) *Coral roads.* The maintenance of well-built coral roads is a relatively simple operation. Fresh unweathered coral of the proper moisture content is the only required repair material. Maintenance is best accomplished while the coral is still moist. Low spots, ruts, and potholes will be filled by shoveling or dumping coral material directly from the truck into the low spots. Such patches, if rolled while moist, will bond onto the original material. If maintenance must be performed when the surface is dry, salt water will be sprinkled on the surface before the start of maintenance operations. Salt water seems to develop a better bond with coral materials than does fresh water. Occasional blading and rolling are necessary to maintain a proper crown and a smooth surface. In dry seasons, sprinkling, preferably with salt water, is necessary to minimize dust nuisance and maintain high stability. In wet seasons, the road will hold up more satisfactorily. If, in prolonged dry seasons, dust and raveling become too serious, the application of an asphalt surfacing may be justified.

(4) *Crushed stone roads.* The maintenance of roads surfaced with crushed stone or other processed materials is similar to that of gravel roads with one exception, the blading and grading operations will not be required as often. The proper blending of the crushed material is essential for the durability of the mixture.

Proper compaction provides the stability by the mechanical interlocking of the particles and, for some aggregates, a cementing of the particles. Surface failures are usually sharp-edged depressions, generally caused by poor drainage. Surface repairs will consist of cleaning down to solid subgrades, replacing with aggregate of same gradation as the original surface, and compacting.

c. *Stabilized surfaces.* Soil stabilization is defined as the process by which soil properties are improved by chemical addition or by additional mechanical effort. Two methods are generally used. One method, mechanical stabilization, involves the controlling of soil gradation and the use of an externally applied force such as compaction to improve the engineering properties of a soil. The second method, chemical stabilization, involves the application of one or more chemicals to a soil to achieve a desired change in its characteristics. Chemical stabilization is generally the most expensive and should only be used if the soil cannot be stabilized mechanically. In most cases, the use of mechanical means, particularly compaction, will be required to supplement chemical stabilization. A wide selection of specific soil stabilization processes and materials are available. In its broadest sense, soil stabilization implies improvement of soil so that it can be used for subbases, bases, and in some instances, surface courses. Stabilization is usually considered when available material is of marginal quality or nonacceptable for use as a base of subbase. The material, by stabilization, is upgraded by increase in strength properties or change in material characteristics. Stabilized wearing surfaces can be used successfully in nontraveled areas such as shoulders where the surface is not subject to abrasion by traffic. Cement- and lime-stabilized materials will be surfaced with a bituminous wearing surface to keep down dust and abrasion of the surface. In the interest of economy, commercial additives will not be used when natural materials can be utilized as stabilizing agents. Thus, the methods of stabilizing used in maintenance and repair will be governed by the characteristics of the soils and available stabilizing materials. The most economical method of stabilization that will produce the desired properties in the available materials will be selected.

(1) *Mechanical.* Mechanical stabilization is accomplished by utilizing rollers to apply force to compact the soil at an established optimum water content. This water content will be established in the laboratory using MILSTD-621A, Method 100.

(2) *Chemical.* Chemical stabilizers accomplish stabilization in two ways: by cementing the soil into a hardened mass and by changing the charac-

teristics of the soil to make it more suitable construction material. The first method generally requires a greater percentage of stabilizing agent and also produces a higher type construction material. In the use of stabilizers to change the characteristics of the soil, the primary objective is to reduce the plasticity index of the soil and make it less susceptible to the action of water.

(a) *Types of commercial stabilizers.*

There are a number of types of admixtures, varying in behavior, that can be used in stabilization; each has its particular use and, conversely, its own limitation. Cementing materials that may be used include Portland cement, lime, asphalt, and mixtures of lime and fly ash or sodium silicate. Many times the use of a cementing material is restricted because of cost. Therefore, low quantities of the material may be added to the soil merely to modify it. Only the more common commercial materials in use today (i.e., bitumen, lime, and Portland cement) will be discussed further in this manual. Additional information can be obtained from TM 5-822-14/AFJMAN 32-1019 and NAVFAC DM-5.

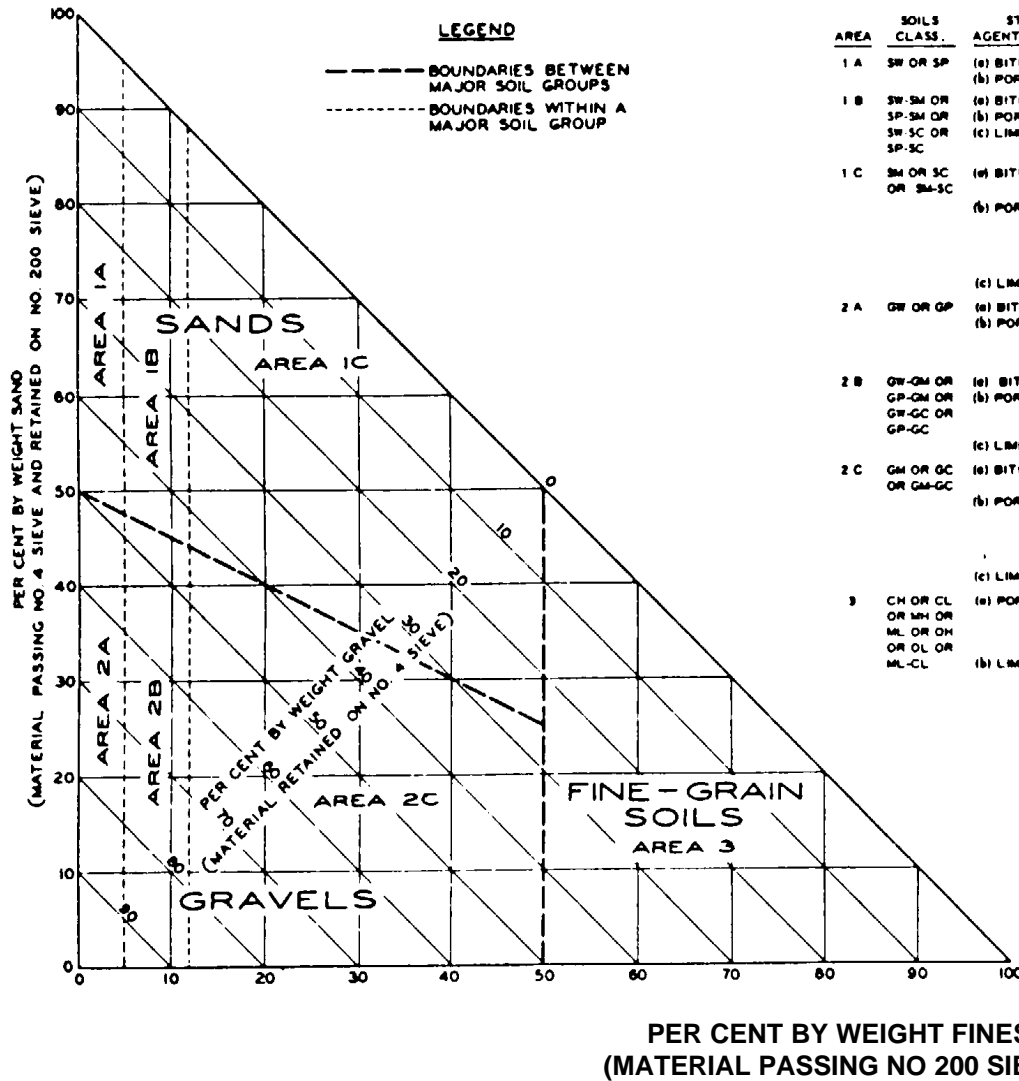
(b) *Selection of stabilizing agents.*

Selection of proper stabilizing agents for a specific project is most important and involves a number of factors; some of the more critical are soil type, desired strength of stabilized courses, cost, weather, water table, and size and location of project. All of these factors will be considered. But the most important single factor to be considered is generally the type of soil. Since, in stabilization work, it is necessary to obtain a uniform distribution of the stabilizing agent in the soil, it is obvious that the pulverization characteristics of the soil are very important. Generally speaking, when a bituminous material or Portland cement is used as a stabilizer, it is imperative that good distribution in the soil be obtained. Therefore, Portland cement and bitumen are more suitable for the stabilization of the granular and less cohesive soils. Since the pulverization characteristics of the soil are of primary consideration in selecting the type of chemical to be used, a gradation triangle has been developed (fig 5-1) to aid engineers in making the selection. It will be noted that the triangle has been divided into three major areas to group the soils. The soil grouping is based on ASTM D 3282 which classifies soil according to the predominant particle size into gravels (retained on No. 4 sieve), sand (passing No. 4 sieve and retained on No. 200 sieve), and fines (passing No. 200 sieve). In this gradation chart, the sand and gravel areas have each been subdivided into three areas. In addition to gradation, this chart takes into account the Atterberg limits of the soil and places certain restrictions on the amount of fine material

passing the No. 200 sieve. This chart is, at best, a general guide and cannot cover all possible conditions. It should be used only to provide knowledge on what types of chemical stabilizers should generally be considered for a specific job. In areas where a particular type of soil has been successfully stabilized, it is recommended that such experience be taken into account in the selection of the stabilizing agent. After the type of stabilizing agent is selected, it is necessary to determine by laboratory tests the optimum additive content. Chemically stabilized soil layers abrade readily under traffic. Thus, it is necessary to provide a wearing surface over the stabilized soil layer.

(c) *Cement.*

Soil-cement and cement-treated bases are uniformly blended mixtures of soil or coarse aggregates and measure amounts of Portland cement and water that have been compacted and cured. Cement stabilization is most beneficial when used with inferior granular materials. Cement content depends upon the kind of soil or material being stabilized and the characteristics desired in the base course. Laboratory test procedures given in ASTM Standard Methods of Test D 558, D 559, and D 560 have been developed to provide guidance in selection of optimum cement content. However, other factors such as weather conditions, desired durability, and strength have to be considered and may govern the cement content. Cement stabilization requires the use of granular materials or soils that can be thoroughly pulverized. Soils and aggregates which have a high silt and clay content, as shown in the soil triangle (fig 5-1), cannot be used. Suitability of a particular aggregate is predetermined by trial mixtures. Standard Portland cement is the usual stabilizing agent, although high-early strength cement can also be used. As a general rule, the cement requirement of soils increases as the silt and clay content increase; gravelly and sandy soils require less cement content for adequate strength than silt and clay. An exception to this rule is poorly graded one-size sand materials devoid of silt and clay require more cement than do sandy soils containing some silt and clay. In general, a well-graded mixture of gravel and sand will require 5 percent or less cement by weight. Poorly graded one-size sands such as beach sands or desert-blown sands will require about 9 percent cement by weight. The remaining sandy soils will generally require about 7 percent cement. The nonplastic or moderately plastic silty soils generally require about 10 percent cement by weight and soils having high plasticity require about 13 percent or more. The water required should be free from excess amounts of organic matter. Any water satisfactory for human consumption is suitable for cement stabilization. Base



AREA	SOILS CLASS.	TYPE STABILIZING AGENT RECOMMENDED	RESTRICTION ON LL, PL & PI OF SOIL	RESTRICTION ON (-200 MATL.)	REMARKS
1 A	SW OR SP	(a) BITUMINOUS (b) PORTLAND CEMENT			SEE NOTE (A)
1 B	SW-SM OR SP-SM OR SW-SC OR SP-SC	(a) BITUMINOUS (b) PORTLAND CEMENT (c) LIME	PI NOT TO EXCEED 10 PI NOT TO EXCEED 30 PI NOT LESS THAN 12		
1 C	SM OR SC OR SM-SC	(a) BITUMINOUS (b) PORTLAND CEMENT (c) LIME	PI NOT TO EXCEED 10 PI NOT TO EXCEED NO. IND. BY EQ: $20 + \frac{30 - \text{FINES CONT.}}{4}$ PI NOT LESS THAN 12	NOT TO EXCEED 30% BY WT	
2 A	GW OR GP	(a) BITUMINOUS (b) PORTLAND CEMENT			WELL-GRADED MATL ONLY MATL SHOULD CONTAIN AT LEAST 45% BY WT OF MATL PASSING NO. 4 SIEVE
2 B	GW-GM OR GP-GM OR GW-GC OR GP-GC	(a) BITUMINOUS (b) PORTLAND CEMENT (c) LIME	PI NOT TO EXCEED 10 PI NOT TO EXCEED 30 PI NOT LESS THAN 12		WELL-GRADED MATL ONLY MATL SHOULD CONTAIN AT LEAST 45% BY WT OF MATL PASSING NO. 4 SIEVE
2 C	GM OR GC OR GM-GC	(a) BITUMINOUS (b) PORTLAND CEMENT (c) LIME	PI NOT TO EXCEED 10 PI NOT TO EXCEED NO. IND. BY EQ: $20 + \frac{30 - \text{FINES CONT.}}{4}$ PI NOT LESS THAN 12	NOT TO EXCEED 30% BY WT	WELL-GRADED MATL ONLY MATL SHOULD CONTAIN AT LEAST 45% BY WT OF MATL PASSING NO. 4 SIEVE
3	CH OR CL OR MH OR ML OR OH OR OL OR ML-CL	(a) PORTLAND CEMENT (b) LIME	LIQUID LIMIT LESS THAN 40 AND PI LESS THAN 20		ORGANIC AND STRONGLY ACID SOILS FALLING WITHIN THIS AREA ARE NOT SUSCEPTIBLE OF STABILIZATION BY ORDINARY MEANS

NOTE: (A) SOIL CLASSIFICATION CORRESPONDS TO MIL-STD-619B. RESTRICTION ON LIQUID LIMIT, PLASTIC LIMIT, AND PLASTICITY INDEX IS IN ACCORDANCE WITH METHOD 103 IN MIL-STD-621A.

Figure 5-1. Gradation triangle for aid in selecting a commercial stabilizing agent.

courses stabilized with cement are more rigid than those constructed without cement, but they ravel quickly if subjected to traffic abrasions and suffer extensive cracking patterns in their surface during the hydration process if high cement contents are used. If cracks are not sealed, water infiltrates into the underlying materials, causing instability. Careful control of proportions, moisture content, and compaction are essential. Thickness of stabilized layers should not be less than 4 inches. A bituminous surface treatment or surface course is generally required to resist the abrasive action of traffic. A curing period is required, but emergency use during the curing period is possible. Soil-cement and cement-treated bases are quickly built with proper equipment in dry weather. However, work is restricted during wet or freezing weather.

(d) *Lime.* The addition of lime to soils will change the plasticity properties and increase the soil strength. Either hydrated lime or quicklime may be used as the stabilizing agent, depending on availability of the type of lime and construction equipment. The reaction of quicklime with soils is similar to that of hydrated lime. But hydrated lime is easier and safer to handle. Quicklime can cause burns and irritations to workmen and should be used with caution. Lime is generally used in the stabilization of clay soils or gravels with clay binder material. The effectiveness of the lime treatment will vary depending on the relative amount of the component minerals. Lime in small quantities (2 to 4 percent by weight) is very effective with clay gravel mixes. In base course construction, much more lime is required for moist fine-grained clay soils than for gravelly clay binder mixes. If used in sufficient quantities, lime will improve fine-grained silty soils; however, it usually will not be as effective with these materials as with clays. The use of lime alone is not recommended for sandy soils. A certain amount of water in the soil is used in hydrating, which in turn gives off heat that produces a drying effect. The percentage of loss of water in a soil has been found to be approximately one-half the percentage by weight of the lime added to the soil. Hence, the application of lime to areas that are unstable due to excessive moisture may actually dry the soil and allow construction work to proceed at an earlier date. Lime stabilized soils must be cured at a minimum of 50 degrees F.

(e) *Fly ash.* Fly ash will act as a pozzolan and/or a filler to reduce air voids in naturally occurring or blended aggregate systems. Fly ash is not normally necessary in fine-grained soils. It can be difficult to thoroughly mix fly ash with fine-grained soils. Coarse silts are generally considered the most suitable soil type for treatment with fly ash. How-

ever, most types of coarse-grained soils can be successfully treated and compared to fine-grained soils. They can be more economical and have a greater resistance to frost action. While pozzolan action is desirable, the amount of calcium oxide in fly ash will vary both from the same source and from other various sources. Fly ash should normally be used as a filler, and additional pozzolans action is employed but not planned for in the design scheme.

(f) *Bitumen.* Only those soils that can readily be pulverized by mixed-in-place construction equipment is satisfactory for bituminous stabilization. Thus, the use of bitumen is limited mostly to the coarse-grained or sandy soils. Soils containing clay and silt having more than 30 percent by weight of minus No. 200 sieve material or a plasticity index greater than 10 are generally not adaptable to bituminous stabilization. The addition of a small percentage of lime may facilitate mixing of the bitumens. Friable soils which possess inherent stability and whose stability cannot be improved by admixing other soils economically are best suited for stabilization with bituminous materials. For stabilization work in which the bituminous material is to be mixed with the soil, such materials as asphalt cements (central plant applications only), cutback asphalts, emulsified asphalts, and tars perform quite satisfactorily. Asphalt cements are usually used for base courses but not for subgrades. The harder grades of asphalt cements (penetration 40-50) (AC-40 or stiffer) will be used in hot climate areas.

The cutback asphalts (grades 70-3, 000) are used in all phases of stabilization. The quantity of cutback material necessary can be approximated by the following surface area formula:

$$p = 0.02a + 0.07b + 0.15c + 0.20d$$

where

- p = percent residual asphalt by weight of dry aggregates
- a = percent of mineral aggregate retained on the No. 50 sieve
- b = percent of mineral aggregate passing No. 50 and retained on No. 100 sieve
- c = percent of mineral aggregate passing No. 100 and retained on No. 200 sieve
- d = percent of mineral aggregate passing No. 200 sieve

The design amount of bitumen and its workability will be determined by laboratory tests or small scale field tests before the project starts. Emulsified asphalt is also utilized in all phases of stabilization. The grade SS-1h is usually used with soils having less than 5 percent material passing the No. 200 sieve; grades SS-1 or CMS-2 are used for soils

having greater than 5 percent passing the No. 200 sieve. Tars conforming to ASTM Specification D 490, grade RT-1 to RT-6, have also been used for soil stabilization.

(g) *Combinations.* The use of various stabilizing agents in combination is often advantageous. The main advantages of using combinations are to reduce plasticity and increase workability so the soil can be intimately mixed and effectively stabilized. Portland cement is an agent used in many combinations. However, lime normally used as a pretreatment is the agent most widely used in combination with others. Lime is usually used to reduce plasticity and increase workability. Although some strength increase is usually noted, Portland cement can now be added to the altered soil for a larger strength gain. Cement fly ash or lime fly ash mixtures are combinations that can be used for most silts. Both of these agents have been used in bituminous emulsion stabilization operations to help control emulsion break and the cure time.

d. *Dust palliatives.* Treatment or processes used to control dust are called palliatives. The primary function of palliatives is to prevent soil particles from becoming airborne. Secondary function includes preventing erosion from the action of wind and other air blast, and from the action of rain and running water. Some palliatives also protect the soil ground surface against penetration of water, acting as waterproofing. Palliatives should reduce the migration of the fine-grained particles which provide stability for the larger particles. Thus, rutting is delayed, and the need for blading the unsurfaced roadway is greatly reduced. Before any large dust prevention project begins with a palliative, small test sections are recommended to assure the palliative performs as desired.

(1) *Water.* Water is the most commonly used palliative. Water must be applied whenever dust occurs which is usually during construction or maneuver activities. Whenever these activities are conducted at night, the amount of water needed is reduced because there is less evaporation. The time, equipment, and manpower required limit the use of this method to that of a temporary expediency.

(2) *Salts.* Salts include both calcium chloride and magnesium chloride. They can be used in flakes, pellet form, or dissolved in water and are shipped in waterproof bags or in bulk. These materials absorb moisture from the air if the humidity is not too low. They are not effective as a palliative under arid or semiarid conditions. They are successful on all types of soil in regions where the relative humidity averages 30 percent or more. When spread on or incorporated into the surface of traveled areas, they attract moisture which helps hold

soil particles in place. Since salts are soluble in water, they are carried away by rain and must be reapplied periodically. Application should be made during periods of light traffic and when rain is not expected for at least 24 hours. Salts should not be applied to dry washed gravel or to dry shifting sands without binder soils (soils passing the No. 200 sieve). They should not be used on plastic clays because the moisture generated will make the clay surface slick. Surface material must be granular with some fines and as smooth as possible to receive treatment. When there is loose aggregate on the surface, it can be mixed with the binder; however, the preferred method is to remove all loose material. If the surface is covered with a heavy cushion of finely powdered dust, this undesirable material should be removed.

(3) *Oils.* \*Oils include any type of petroleum derived substance of varying viscosity such as crankcase waste, bunker oils, crude oil, marine oils, motor oil, or residue from storage of asphalt base crude oils. The heavy grades of oil such as Bunker C or waste oils will require heating for transfer of materials and application. The higher viscosity oils will be used for soils containing a high percentage of sand or gravel or where the surface is loosely bonded. Oil will be applied only on dust-free, moist surfaces. The low viscosity materials are applied to bind the surface and prevent displacement of the fine particles. Oils are absorbed by soil to form a shallow treated area. In all cases, excess oil standing on the surface must be blotted by spreading on sandy soil; otherwise, a hazardous condition will exist. Use of oils as dust palliatives must meet all local environmental standards; precautions will be taken that the soils do not percolate into the water table or streams. Oils can be washed off the road surface by rains if it has not had time to penetrate into the soil. Treatments will be repeated each year, or as often as necessary, to keep dust in place.

(4) *Asphalt emulsions.* Asphalt emulsion is a blend of asphalt cement, water, and an emulsifying agent, and is available as either a cationic or anionic type. For dust control, the slow-setting anionic types SS-1 and SS-1 are preferred, although the slow-setting cationic types CSS-1 and CSS-1 also can be used. It is preferable to use the asphalt emulsions undiluted. The emulsion breaks upon contact with the soil, separating into the water and asphalt phases. On a porous soil, the asphalt phase penetrates and cures in several hours under favorable conditions. On an impervious or tight soil surface, an asphalt film will remain on the surface and

\*Oils have been condemned for use by the Environmental Protection Agency (EPA) in areas subjected to their surveillance.



must be blotted with a thin coating of sand before traffic is applied.

(5) *Proprietary products.* Commercial dust palliatives are on the market under various trade names. These proprietary products are usually based on either chloride materials, asphalts, or some other material. Concerning any proprietary products, the buyer should beware of any extravagant claims made by commercial companies and require a small scale test section.

**5-3. Causes of distress**

Any of the following causes can lead to distress. Care must be exercised to assure that a stabilized surface will not be excessively loaded before it has achieved its full strength, or distress will result.

a. *Weathering (erosion).* Weathering or raveling of the surface particles is a major cause of distress on nonpaved surfaces. The severity of this distress is related to the drainage conditions present. When the surface drainage is controlled to provide smooth flow at low velocity, this distress is minimized.

b. *Water intrusion.* Stabilized surfaces often develop cracks or faults which can result in water intrusion. This water will weaken the area around the crack and will eventually lead to greater distress.

c. *Construction deficiencies.* Construction deficiencies are listed below.

(1) *Poor grade and surface smoothness.* Poor grade control during construction will adversely affect the drainage of the surface and will cause problems. Roughness caused by poor blading (or any other cause) will cause corrugations and/or potholes to be formed.

(2) *Improper mixing.* Improper mixing will cause weak or deficient areas within the stabilized surface. This type of distress is often caused by inadequate or improper use of mixing equipment.

(3) *Poor proportioning.* An inadequate quantity of stabilizer can lead to difficulties similar to improper mixing. Without proper proportioning the stabilized surface will not perform as designed.

(4) *Improper compaction.* An improperly compacted surface will be less durable and more subject to failure. The proper density will help ensure a more water tight surface that is stable and durable.

(5) *Material deficiencies.* The use of inadequate or inadequately prepared materials will cause distress in the stabilized surface.

**5-4. Types of distress**

The most common types of distresses on miscellaneous surfaces are included in this section.

a. *Potholes, ruts, and surface irregularities.* These distresses should be corrected as soon as pos-

sible before they develop into larger problems. These distresses are common to most types of surfaces.

b. *Corrugations or washboarding.* All gravel roads tend to develop transverse or nearly transverse waves commonly called corrugations or washboarding. These corrugations may develop into ruts as deep as 4 inches ranging 1Y2 to 3 feet apart. This problem will continue to spread and disrupt traffic until it is repaired. Traffic impact tends to make corrugations progressively more pronounced once they are started.

c. *Soft spots.* Soft spots indicated by rutting or shoving of the surface are generally caused by an excess of moisture or the use of an unstable material. These areas require improved drainage to eliminate excess water and removal of such unstable materials as peat, muck, or plastic clays, and replacement with suitable selected material. When adequate repair of soft spots cannot be accomplished immediately, the deficiency can be temporarily corrected by adding crushed rock or gravel to the affected area.

d. *Cracking.* Cracking is a normal characteristic of certain soils (usually those with a high percentage of clay) and also for some stabilized soils. The cracks in many soils are due to moisture loss, and they will tend to knead together with traffic. When these soils are used as a base course, they cause no problems if water is kept from them. The cracking in soil cement is due to shrinkage and does not impair its performance as a base course. These shrinkage cracks normally reflect through a bituminous surface and will require sealing when cracks are greater than 1/8 inch wide.

e. *Dust.* During dry weather, dust is not only a nuisance, but it is dangerous and wasteful (fig 5-2). If not kept in check, dust is detrimental to aircraft as well as vehicles. Earth and soil-aggregate surfaces give satisfactory service at low maintenance cost when dust is prevented. Blowing dust represents loss of binder material leading to potholes and raveling of surfaces which then require maintenance and repair.

**5-5. Methods for maintenance and repair**

A general description of the equipment and methods used in the maintenance and repair of unpaved surface areas are discussed.

a. *Equipment.* Certain equipment are needed for maintenance and repair of unpaved surface areas.

(1) *Application of material.* Materials are normally either applied by spray application or mechanically spread on the surface.

(a) *Water truck.* The water truck will be equipped with a spray bar and an adequate pumping



Figure 5-2. Dust created by a passing vehicle

system. It will be capable of accurately metering water at various rates. A conventional asphalt distributor can be used as a water truck.

(b) *Mechanical spreader* Mechanical spreaders can be truck-mounted, separate units, or self-propelled. They are used to evenly spread material. The spreader will be capable of having a controllable rate of application. Self-propelled types are the most widely used and provide the best performance.

(2) *Mixing*. The type of mixing equipment used will depend on the type of materials being mixed and the amount to be mixed.

(a) *Disk harrow and cultivator* These pieces of equipment (normal agricultural equipment) are pulled through the soil to mix it (fig 5-3). These are relatively shallow mixers and must make several passes to achieve a good mix.

(b) *Pulvermixer* The pulvermixer will be a size capable of thoroughly mixing the materials as required (fig 5-4). The pulvermixer will also be capable of breaking up the soil into its basic particle size.

(c) *Grader* The grader is used for shaping and to achieve the final grade and surface smoothness (fig-5).

(3) *Compaction*. The type of compaction equipment used will depend on the type of soil that is compacted.

(a) *Sheepsfoot roller* Sheepsfoot rollers (fig 5-6) used for compacting subgrade have metal projections for compaction, and these rollers are used for compaction until the roller "walks-out." Another roller, usually rubber-tired, will have to follow or

finish roll after the sheepsfoot. The sheepsfoot roller is useful in compacting fine-grained cohesive soils.

(b) *Rubber-tired roller*. The rubber-tired roller (fig 5-7) is very versatile and effective at achieving the required density. These rollers can vary in size from 7 to 35 tons. To achieve maximum compactive effort, the tire pressure should be maintained at approximately 90 pounds per square inch or the maximum that the soil can support without excessive displacement.

(c) *Vibratory roller* Vibratory rollers (fig 5-8) are usually self-propelled with either all steel drums or a steel compaction drum and rubber-tire drive wheels. The rollers are very versatile and are effective at compacting most types of materials especially cohesionless soils.

(d) *Steel-wheel (static)*. Steel-wheel rollers are used mainly as finished rollers to obtain a smooth final surface. For small repairs, this roller may provide adequate compaction by itself. Vibratory rollers run in the static mode may be used.

b. *Repair methods*. Methods needed to repair the road surface are listed below.

(1) *Regrading*. Regrading consists of scarifying the road surface, reshaping the road, including the shoulders and ditches, and thoroughly recompacting the reshaped material (fig 5-9). Gravel or crushed stone may be added to the reshaped roadway to assist in the elimination of distresses such as potholes and rutting. Care must be taken not to cut too deep with the grader blades. A deep cut often causes the blade equipment to "chatter." The cause of the chattering also develops corrugations or washboarding.



Figure 5-3. Cultivator mixing soil.

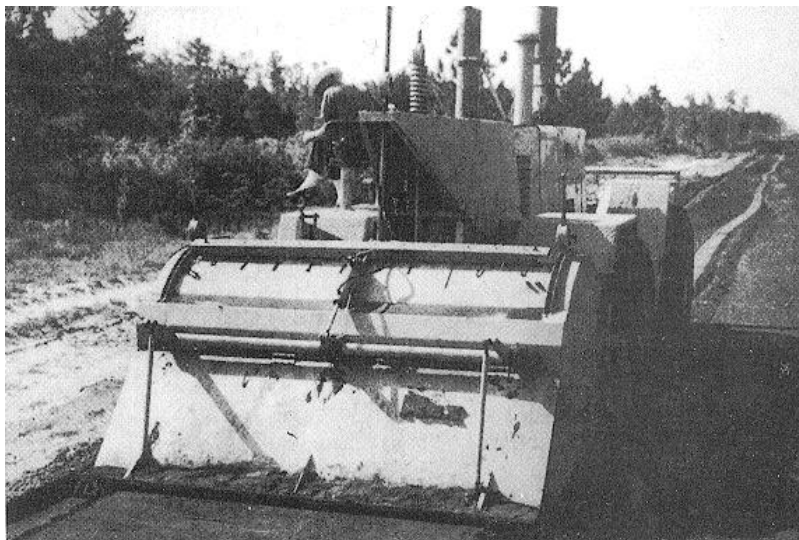


Figure 5-4. Pulvermixer.

(a) *Adjustment of moisture content.* Loosened, dry material will not compact properly; therefore, blading must be done soon after rains. When a very dry surface cannot be reworked, a scarifier can be used to bring moist material from beneath the surface. This moist material then will be blended with the surface material to make a workable mixture. Water may be added sparingly if needed.

(b) *Sandy soil.* Sandy soil roads should be bladed smoothly with a rather flat crown as this

shape tends to retain moisture longer and is not as subject to erosion as is a high crown. In arid regions, loose materials should be bladed off the roadway.

(c) *Clay and silt.* Clay and silt soils should not be bladed while they are saturated. The crowns on such roads which inherently have a tendency to retain moisture will be somewhat higher than the edges in order to facilitate drainage.

(2) *Blade and sled drags.* Blade and sled drags

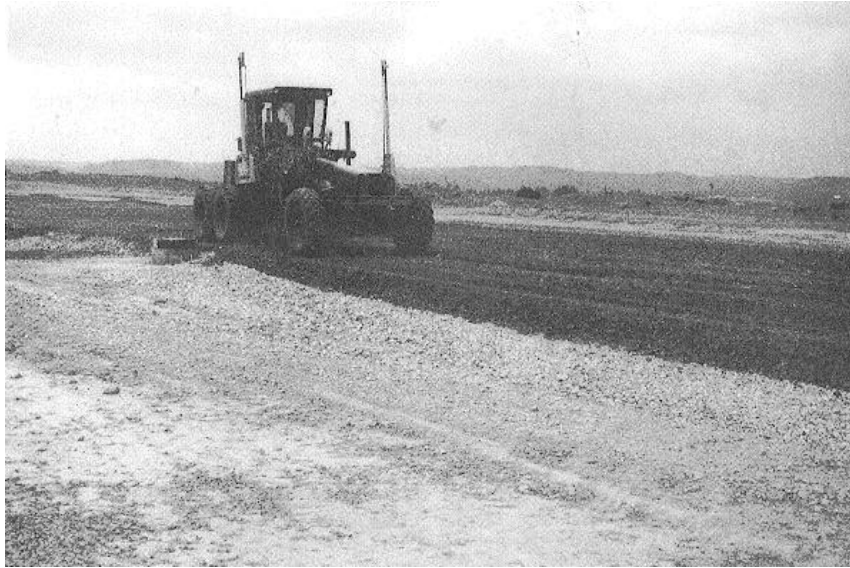


Figure 5-5. Grader leveling road surface.

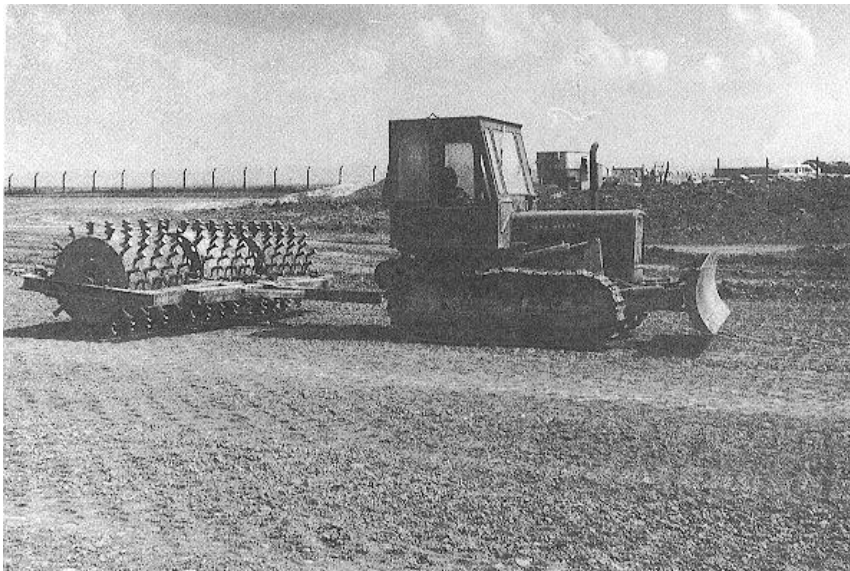


Figure 5-6. Sheepfoot roller.

are used when minor repairs are required and the use of a grader is not required. This method can be used to repair potholes, ruts, and other surface irregularities.

(3) *Improve drainage.* To provide the surface drainage, the proper grade and surface smoothness must be provided. Drains and ditches should be provided for proper surface and subsurface drainage (see chap 7).

(4) *Pothole filling.* Most potholes caused by

traffic displacement of material are shallow and readily filled by blading the surface when moist with a grader. Deeper holes require filling with more material than is normally available by blading. In filling deeper holes, greater care must be taken to ensure that adequate compaction is obtained in order to prevent the hole from reforming. The new material must contain sufficient moisture to allow satisfactory compaction.

(5) *Cement stabilization.* Cement requirements



Figure 5-7. Rubber-tired roller



Figure 5-8. Vibratory roller.

vary for each aggregate. The quantity actually required is based on laboratory tests of specimens subjected to freezing and thawing or wetting and drying. One bag of cement weighing 94 pounds is assumed to have a loose volume of 1 cubic foot. The amount of cement (bags) per square yard of a compacted base 6 inches deep for various proportions of cement is:

<u>Cement Volume, Percent</u>	<u>Bags/Square Yard</u>
8	0.36
10	0.45
12	0.54

Water requirements depend upon optimum demand of aggregate cement mixture, moisture contained in aggregate, and rate of evaporation during stabilization.

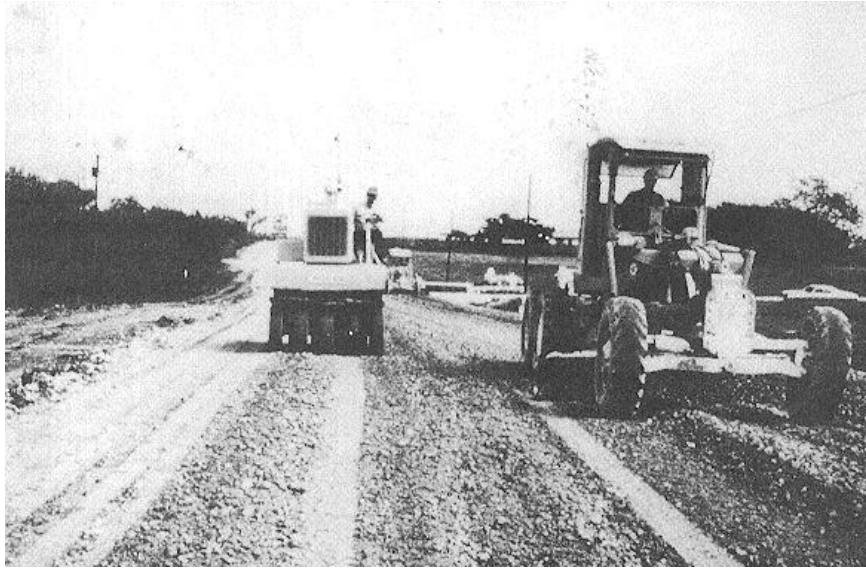


Figure 5-9. Regarding and rolling road surface.

The amount of water added should not exceed that required for workability and satisfactory compaction.

(a) *Area treated.* The area will be divided into sections of such size that necessary work from adding cement to final finishing is completed in one working period. This construction process will be continuous and completed as soon as possible after the cement is mixed into the soil.

(b) *Preparation of area.* All unsuitable material and soft areas will be removed and replaced with suitable materials. Placement of a stable subgrade beneath the area to be treated is important in soil-cement construction, and will be accomplished prior to commencement of operations. If any aggregate is to be added to the soil being treated, it will be spread evenly on top of it. The soil being stabilized will be loosened with a scarifier to a sufficient depth so that when the material is recompacted, it produces the required final thickness. The loosened soil is then pulverized with repeated trips of weighted disk, spring-tooth harrows, or preferably rotary tillers.

(c) *Spreading cement.* The cement will be spread in accordance with the proportions of soil to cement determined by laboratory tests. In maintenance and repair operations the method usually consists of spacing bags of cement horizontally and transversely at definite intervals to give required proportions (fig 5-10) and opening the sacks and distributing the cement by hand. This will be followed by light harrowing to give uniform distribution (fig 5-11). If suitable equipment is available, bulk cement can be spread from trucks by means of a mechanical spreader (fig 5-12).

(d) *Dry mixing.* Thorough mixing of the soil and cement is accomplished by means of the same equipment used to pulverize the soil (fig 5-13). The number of mixing operations is largely dependent on the type of equipment used and will vary to obtain the specified results. Special care will be taken to ensure a uniform mixture where fieldmixing methods are employed. If feasible, materials can be hauled to a central plant for mixing and returned to the site for distribution.

(e) *Adding water.* Water will be added by repeated sprinkling of  $\frac{1}{2}$  to 1 gallon per square yard (fig 5-14). Each sprinkling will be followed by harrowing or disking to facilitate absorption of water and minimize evaporation loss.

(f) *Moist mixing.* Moist mixing with cultivators, plows, and rotary tillers will start immediately. Meanwhile, water content will be equal to or slightly in excess of optimum water content. On large jobs, it is often more economical to use stationary or traveling mixing plants to conduct the operations of dry mixing, adding water, and moist mixing. If mixing requires an excessive amount of time, less durable mixtures will result.

(g) *Compaction.* The benefits derived from soil cement depend to a great extent upon the degree of compaction of the mixtures. Construction will be keyed to the initial set of the cement. A sheepfoot roller is generally used for compaction, and proper cross section will be maintained with a motor grader. Moisture content will be kept at optimum content during this and succeeding operations.



Figure 5-10. Hand spreading bags of cement.

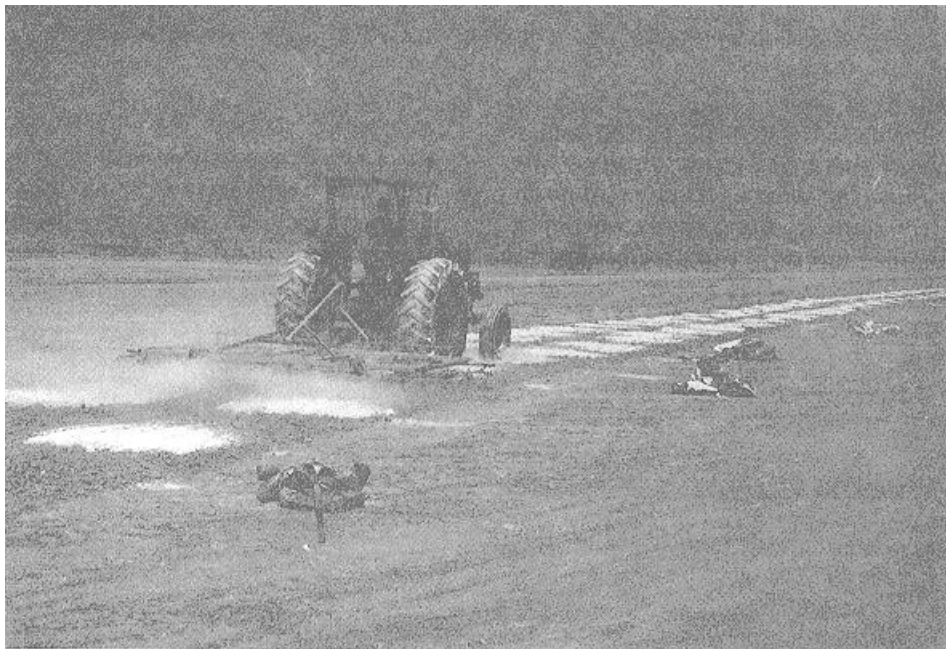


Figure 5-11. Spread lime with a harrow.

(h) *Finishing.* This process requires the use of motor grader, rubber-tired roller, and steel-wheel roller. The length of a section will be such that compaction and finishing are completed about 6 hours after beginning water application (fig 5-15).

(i) *Curing.* Soil-cement mixtures will generally require a curing period of 7 to 8 days, depending upon the amount of cement used. Since a bituminous surface is often added over this base,

application of a bituminous prime or seal coat to facilitate curing is convenient. Curing can also be accomplished by covering with earth or with thoroughly wetted straw. If covered with 2 inches of earth or straw, the base may be used by rubber-tired vehicles after 1 day of curing. Application of bituminous surface should be deferred to allow any weak spots to develop under traffic, and these will be repaired as part of the surfacing operation.



Figure 5-12. Spreading cement directly from bulk carrier.

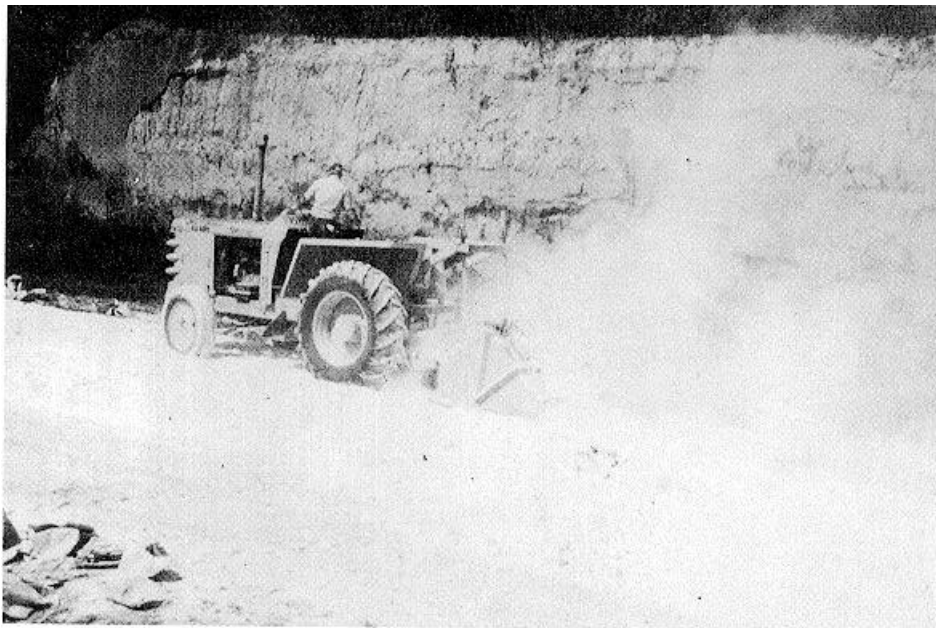


Figure 5-13. Dry mixing cement with pulverizer.

fore placing bituminous materials, soil cement will be cleaned by blading and brooming to remove unbound particles.

(6) *Lime stabilization.* Field equipment required and the steps employed in lime stabilization are similar to those used for soil-cement stabilization. When lime is applied in a dry state, the soil and the lime will be thoroughly blended at a moisture content below optimum. Water will then be blended into the dry mix in amounts necessary to bring the treated soil to the

optimum moisture content for compaction as determined from laboratory tests of lime treated soil. The optimum moisture content from these tests includes additional water for hydration. Certain precautions are required when working with dry lime, including not allowing work on windy days and providing proper protective clothing. Quick lime can be slaked into a thin slurry in a large tank and then pumped into a distributor truck from which it can be sprayed on the road base (fig 5-16).





Figure 5-14. Adding water to the soil.



Figure 5-15. Finish rolling with a rubber-tired roller.

Lime-soil mixtures will be compacted to relatively high densities because the increased strength from cementing action is not apparent after compaction until a period of curing time. The compacted surface should be closed to traffic and kept covered and moist for a 5 to 7-day curing period.

(7) *Fly ash stabilization.* The equipment and construction techniques used for fly ash stabilization are similar to those used for soil-cement stabilization. Fly ash can be applied in a dry state. However, due to

dusting problems, it is normally distributed as a slurry when the job is large enough to be economical. The user time will vary with the climatic conditions, but it should be approximate 1 week to obtain sufficient strength for traffic.

(8) *Bituminous stabilization.* The type and quantity of bitumen to be used for stabilization must first be determined (see 5-2(3)(g)). The actual construction operation is similar to that discussed for lime and cement stabilization.

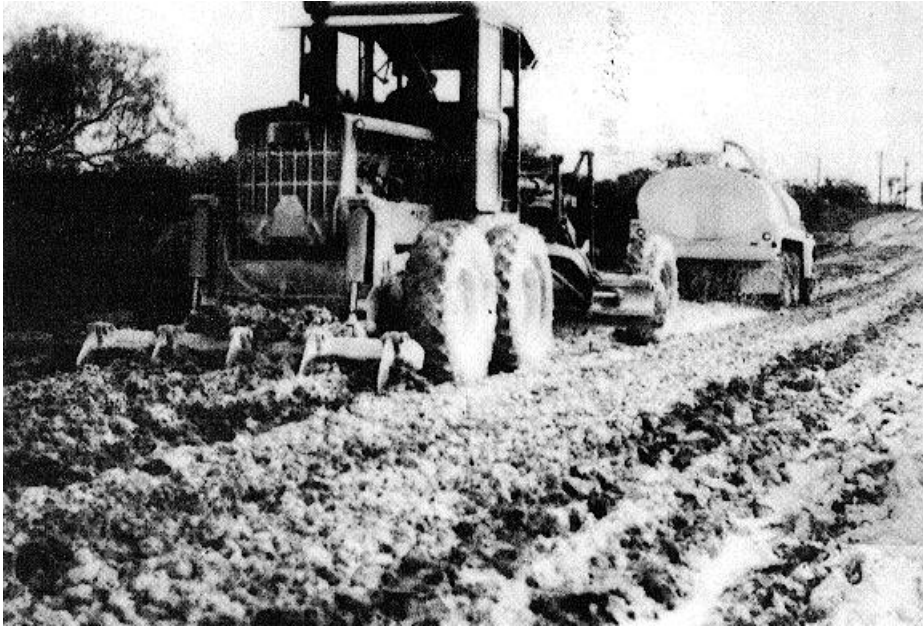


Figure 5-16. Spraying lime from a tank truck and immediately mixing treated soil.

However, control of a bitumen-stabilized course during construction is most difficult. There is not a set procedure or test that can be utilized to determine exactly when a mixture should be compacted. The best method of determining this is by trial and error. The mixture should be aerated until the moisture content is satisfactory for compaction. As soon as the mixture can be compacted without shoving and moving under the roller, compaction operations should be started.

When using cutbacks in stabilization, the soil mass will be aerated before compaction so that some of the volatile material will be driven off and the soil mass allowed to partially harden. Curing time will be extended to ensure complete volatilization. It is possible to use the asphalt-stabilized material as a wearing surface.

(9) *Combination stabilization.* Combination stabilization will use the equipment and techniques employed for the particular material being used.

## SHOULDERS AND ROADSIDES

**6-1. Shoulders**

Shoulders serve as safety strips for emergency use or for temporary parking of vehicles. They provide lateral support for pavements and protect their edges from raveling, undermining, abrading, and breaking. As elements of surface drainage systems, they also convey storm runoff from the edge of the pavement to ditches, inlets, or natural watercourses. Roadsides are areas beyond the shoulders which affect the safety or structural performance of pavements.

**6-2. Types of shoulder surfaces**

Shoulders may have earth, stabilized, or treated surfaces. Material used is generally of lower quality than that used for the adjacent pavement. Shoulders will have the stability necessary to support traffic in emergencies and will resist washing and displacement without excessive maintenance. Contrast in color or surface texture is desirable to discourage use of shoulders as a traveled way.

*a. Earth.* Native soil, unstabilized or without turf cover, is generally unsatisfactory as a permanent shoulder material. Fine-grained soils are too soft when wet, and sandy materials are too unstable when dry for use by traffic in emergencies. Where soil is naturally well-graded and rainfall is low, earth shoulders are satisfactory for pavements carrying light traffic.

*b. Sod.* Sodded or turfed shoulders are superior to earth and will be developed and maintained wherever climatic, soil, or traffic conditions permit. They are unsuitable and costly to maintain along heavily traveled narrow pavements, at sharp turns, or in congested areas where traffic repeatedly used the shoulder. Since turf increases the height of the shoulders, the surface will be cut down before seeding.

*c. Soil aggregate.* Where higher stability is required, existing soil will be blended with aggregate, or imported material will be placed to provide a soil-aggregate shoulder surface. Aggregates will be pit-run, graded or processed materials (including gravel, stone, slag, chats, mine tailings, talus rock, scoria, coral, shell, iron ore, chert, shale, caliche, cinders), or sand-clay. Well-graded crushed stone produces the most desirable shoulder material. Depth of the shoulder material should be 4 to 6 inches depending on the depth of the adjacent pavement structure. Material should not exceed 1 inch in size or grades under 5 percent. On steeper grades, a coarser material will be used. But, it will be of such character as to remain in place during adverse environmental periods. Also, it will be easily compacted.

*d. Bituminous.* Bituminous-surfaced shoulders will be provided where complete dust control and maximum safety are required. With this type of shoulder, stability and control of erosion are also improved. Bituminous shoulders will be generally used only along high-quality pavements, on airfields, and on roads which carry a large volume of traffic.

*e. Dual type.* Road shoulders are sometimes partially paved, particularly along narrow pavements, inside curves, and at intersections or turnouts. The shoulder area adjacent to the pavement will be stabilized by surfacing with soil-aggregate or bituminous material; the outer portion will be earth or sod. Where porous aggregates are used for shoulder construction, care will be taken to ensure that adequate provisions for drainage are made and maintained.

**6-3. Geometrics**

General geometric information on shoulders is available in the following paragraphs.

*a. Slope.* Shoulders will be maintained such that they are flush with or slightly below the edge of pavement and slope away from it. The only exception will be along the high side of pavements that are designed for drainage in a single direction. Criteria governing cross slope include class of road, safety requirements, and the necessity for obtaining positive runoff of surface waters. Steeper slopes will be required for roads and walks on steep grades and at the foot of hills to minimize longitudinal flow of water or pavement ponding.

*b. Width.* The minimum desirable width of road shoulders for light traffic is 4 feet. For high-speed traffic and where vehicles may have to park clear of pavement, the minimum desirable width is 10 feet. Shoulder widths for airfield pavements vary according to class of airfield and specific design.

*c. Shape.* The outer edges of road and walk shoulders will be rounded. This section is economical, more easily maintained, and much safer than the abrupt type.

**6-4. Types and causes of shoulder distress**

*a. Erosion.* Erosion is the removal of material by either wind or water. Erosion is a major problem on untreated shoulders. When water is not adequately dispersed, erosion will take place even where sod has been placed.

b. *Rutting.* Rutting from traffic is a severe problem with earth shoulders and is one of the basic reasons for the low utilization of this type of shoulder. The rutting potential will be greatest when the shoulders are in a saturated condition.

c. *Water intrusion.* Water intrusion will cause damage to the shoulders by weakening the subgrade. Water will enter either by penetrating the surface or by percolating up from underneath. The damage caused by the water will depend on the type of material which makes up the shoulder.

d. *Slips and slides.* A slip or slipout is a slope movement or failure that occurs because of a subsurface fault of slipping plane. A slide is a sloughing or collapse of a slope. Both types of failure can obstruct or cover pavements and drainage facilities. A slip is caused most commonly by movement of an earth mass down an inclined plane lubricated by seepage of storm runoff or by ground water. The plane is usually the surface of an impervious soil or rock layer where ground water is collected and trapped. Slides result from construction of steep cut or fill slopes. Slides are also caused by washing or saturation of the slope by surface or ground water, frost action, weathering, vibration from blasting, excavation at toe of slope, overloading at top of slope, or other mechanical disturbances.

e. *Settlement.* A settlement is a downward movement of a section of the shoulder. The settlement is normally caused by insufficient compaction during construction.

## 6-5. Methods of shoulder repair

Shoulders will be maintained with a tight smooth surface flush with or slightly below adjoining pavements to correct slope, width, and section. Maintenance and repair methods differ according to type of shoulder surface but generally involve leveling of ruts and washes, filling of low areas, and cutting down high areas to proper grade and slope. Shoulders will be maintained primarily to protect the basic pavement structure, eliminate traffic hazards, and ensure proper drainage. Protection of pavement edges is essential and is assured if proper maintenance practices are followed. During blading and dressing of shoulders, materials will be distributed evenly over the shoulders and not left as a ridge along the pavement. Where soil erodes easily, fills will be protected by placing a small dike at the shoulder edge with openings placed at specified intervals. This practice will confine surface water to designated areas where a paved or sod flume can be provided.

a. *Equipment.* General light earth-moving equipment will be adequate for all repairs.

A grader is useful for removing deformations and properly shaping the shoulders.

b. *Repair methods.* A large part of repairing shoulders and roadsides involved correcting problems with drainage which has often caused the problem. Chapter 7 contains more detailed information on repair methods in regards to drainage.

(1) *Dikes, flumes, and culverts.* Dikes, flumes, and culverts will be used to intercept and divert surface water. These structures will be inspected for any breaks, cracks, or joints. These structures must be kept free from debris or anything which would inhibit flow.

(2) *Piling, cribbing, and retaining walls.* Piling, cribbing, and retaining walls are necessary where shoulders are placed near steep slopes that must be stabilized. The use of each method is dependent on the particular requirements which arise. For the retaining walls, the weep holes for drainage from behind the walls will be inspected and cleaned or replaced if they become clogged. All structures should be repaired or replaced if they are damaged.

(3) *Sodding and seeding.* Heavy sod will be developed as close to the edge of pavement as possible. Dense sod will not be disturbed on self-draining areas. Damaged areas should be filled with pulverized soils to 3 inches below surface of pavement. New sod of proper thickness should be placed and tamped thoroughly. It is essential to have the finished surface flush with pavement. Occasional watering of new sod is necessary if rainfall is insufficient. Shoulders that have become high enough to interfere with drainage need to be corrected. If the sod must be removed below the root line, select topsoil will be placed on the subgrade to speed the growing of new sod. Fertilizer will be applied before final harrowing and smoothing. Appropriate cover-crop seeding will be done if the work is accomplished in the fall. Sod shoulders that have been raised above the pavement grade by frost action will be rolled early in the spring to compact the sod and soil to its original position. Regular mowing of sod shoulders will be accomplished to improve the appearance, help grass spread and reseed, and form mulch from the cuttings.

(4) *Filling and shaping.* Shoulders and roadsides must be kept in good condition through filling and shaping to maintain smooth surfaces.

(a) *Earth shoulders.* Earth shoulders are particularly subject to rutting and erosion. Periodic maintenance consisting of such operations as filling of ruts and washes and shaping with motor graders are necessary to keep the shoulders in the desired condition.

Earth shoulders will not be worked when they are excessively wet or dry. The suggested operational method is to pull material up to pavement edge and then spread evenly over the entire shoulder. A motor grader can be equipped with an auxiliary blade so that the shaping can be done in one operation. When it is necessary to grade shoulders that have become high, the excess material will be pulled onto the pavement, unsuitable material removed, and the balance hauled to low spots or used to widen fills. When shoulders are graded to proper sections and it is necessary to fill eroded spots, the material will be imported. Sand shoulders on high fills which are subject to wash will be stabilized by blading off 3 or 4 inches of sand, blending and rebuilding with clay, and then sodding or seeding.

(b) *Soil-aggregate shoulder.* Frequent blading is required to maintain smooth and even surfaces and to prevent water ponding on the pavement or in ruts. This may best be done when the surfaces are damp and pliable. No ridges will be left on shoulders or adjoining pavement after blading. The piling of aggregate on shoulder edges will be avoided. If the material is loose and unstable, binder soil will be added in the amounts required. If shoulders are high, the excess material that is bladed off will be used to fill low spots or widen fills. Soil that has worn, washed, or blown off shoulders will be replaced with the best selected material available. Soil will not be obtained from slopes and grassed ditches of proper cross section, but will be obtained from suitable borrow areas. It is preferable to blade soil-aggregate shoulders in the spring and fall of each year.

(c) *Bituminous shoulders.* Bituminous treated or oiled surfaces will not be maintained by blading. Maintenance and repair methods are described in chapter 3 for the appropriate class of bituminous surface or pavement. Resealing is required to maintain an impervious surface.

## 6-6. General maintenance

Road intersections and shoulders need to be kept clear of all obstacles to provide an unobstructed view for vehicle traffic and pedestrians.

(a) *Road intersections.* Vision at intersections and railroad crossings will be unobstructed, whether or not traffic is regulated or protected by signs or signals. Signs, poles, shrubs, stockpiles, and temporary structures will be relocated or removed, weeds, cut, and snow removed with this end in mind. Intersections will have minimum sight distances of at least 100 feet in urban areas and 150 feet in rural areas. This may involve flattening or terracing cut slopes and removing other obstructions.

Guidance contained in the "Manual of Uniform Traffic Control Devices for Streets and Highways" will be used for appropriate signs, signals, traffic separators, and other traffic control measures.

(1) Paved intersections will be kept free of loose materials by sweeping regularly with heavy-bristled push or power brooms. Accumulated debris will be deposited on low eroded shoulder areas.

(2) To prevent loose aggregate on side roads from being scattered on pavement, the approach area will be stabilized with binder soil or a bituminous treatment applied.

(b) *Roadside vegetation.* Roadside vegetation needs to be controlled predominately for safety concerns, but also for drainage and accessibility considerations.

(1) Weed mowing along roads is not accomplished for the sole purpose of improving appearance. If weeds are allowed to grow high along shoulders, vehicles tend to shy away from the road edge. This results in vehicles remaining in the center of the road and the loss of full use of the pavement. Also, dangerous traffic conditions occur due to the loss of sight distance around curves. Weed cutting in the fall is also necessary in some locations to reduce drifting snow. In mowing and weed cutting, the entire shoulder will be cut. Signs, markers, headwalls, guardrails, and bridge approaches will be kept completely visible, both in front and behind. Brush or shrubs will not be permitted to grow under bridges or at inlets or outlets of drainage structures. The ground under and around timber structures will be kept free of dry brush, weeds, and other flammable materials.

(2) Several documents have guidelines on the eradication of noxious weeds, mowing, disposal of grass, and disking or spraying and burning of roadside vegetation. Grass will be preserved and planted where it assists in preventing soil erosion. Roadside improvement will be directed toward the elimination of harmful and unsightly vegetation and toward encouragement of planting of vegetation beneficial for erosion control and appearance. Shoulders and shallow ditches will be seeded with varieties of low-growing dense grass. Sod or plant vines will be utilized when grass seed will not grow on eroding slopes.

(3) Trees and shrubs will be preserved unless they present a traffic hazard. Overhanging branches will be trimmed to provide a minimum vertical clearance. All unsound and dead limbs overhanging the roadway will be removed. Trees that interfere with visions or side clearance will be trimmed or removed. Dead trees and trees with weakened roots or top support, which might endanger traffic by falling across roadway, will be removed.

Planting of trees and shrubs will be regulated so they will not interfere with reasonable future widening or improvement, maintenance operations, overhead utility lines, vision at intersections, railroad crossing, or inside of curves.

(4) Maintenance materials will be stockpiled at economical and convenient intervals except where the material is secured easily from commercial plants. Stockpiles will be placed and maintained so that they do not constitute a hazard, and will be kept clear of

shoulders, ditches, drainage channels, structure openings, and airfield clearance zones. Materials should not be stored where truck loading is required on inside shoulders of curves, near crossings, or on hills where sight distances are short. Stockpiles or pit- or crusher-run materials require careful handling to avoid segregating coarse and fine materials. Where shovels, cranes, or loaders are used in stocking and loading, materials will be spread in layers to prevent segregation.

## DRAINAGE OF PAVEMENTS

**7-1. Drainage control**

Adequate drainage of surface and ground water is one of the most important considerations in the design, construction, and maintenance of roads, railroads, airfields, parking areas, and cantonments. Disposal of surface runoff and removal of excess ground water are vital to the stability of serviceability of foundations and pavements. The entire serviceability of a pavement depends on the adequacy of the drainage system in that a washout of a single culvert may close a facility to traffic at a vital time. Properly designed and constructed drainage systems are equally important to the functioning of cantonment and training areas. Water is directly or partly responsible for most pavement failures and deterioration. Proper drainage is a fundamental of preventive maintenance. All pavement failures should be investigated for deficient drainage, which will be corrected, if possible, to prevent its recurrence.

*a. Ponding or delayed runoff of surface water.* Although sometimes incorporated as a deliberate feature of economical drainage design, this problem may cause seepage unless the soil involved is impervious or protected by a waterproofed layer. Water will not be allowed to pond on pavements because it interferes with effective and convenient use of traveled areas and introduces hazards such as skidding or loss of steering and braking control. Water standing on a pavement surface can also seep into the base course unless the surface is tightly sealed.

*b. Water saturation and pavement foundation weakening.* Bearing capacity of subgrades and bases varies with moisture content. Load-carrying capacity of subgrade is highest at optimum moisture content (about 10 percent for sandy soils and from 12 percent to about 25 percent for silt and clay soils). Drying of some materials and saturation of others lower stability. Plastic soils with large silt and clay content shrink when dried and swell upon wetting. Drying of foundation soils is rare because the pavement structure deters evaporation. Moisture control of subgrades and bases is therefore largely a problem of drainage. Excess water comes from percolation through and along the edges of the pavement, from underground seepage and capillary rise, and in areas where the water table is naturally high.

**7-2. Types of drainage systems**

All drainage systems fall into two classifications: surface or subsurface, depending on whether the water is above

or below the surface of the ground when it is first intercepted or collected. Where both types of systems are required for effective maintenance and protection of pavements, it is generally good practice for each system to function independently.

*a. Subsurface drainage.* Subsurface drainage will be required in areas where ground water is encountered near the base of foundations and pavements. The ground-water table is relatively close to the surface in swampy and coastal areas and in certain inland areas. Surface water can also seep down through open or unsealed surfaces and move laterally along the top of impervious strata to form a subsurface lake or perched water table. Subsurface drainage will be provided to intercept, collect, and remove any flow of ground water into the base course or subgrade; to lower high-water tables; to drain water pockets or perched water tables; or any combination of these purposes. A subsurface drainage system comprises facilities to collect and dispose of water that occurs below the surface of the ground. Subsurface drainage facilities include open-jointed, perforated, or porous collector pipes; conduits; observation risers; cleanouts; filters; blind drains; outlet structures; and appurtenant works as required (fig 7-1).

(1) *Collector pipes.* These pipes are buried in porous material and they conduct the water away. The pipes are usually slotted or in some way porous. If slotting or holes in subdrain pipe cannot be properly sized to prevent soil intrusion, a filter blanket or filter fabric will be needed. The size and type of pipe required is based upon the estimated drainage requirements.

(2) *Conduits.* Conduits usually connect with several collector pipes to carry the water away. These conduits are large enough to carry the flow and to accommodate some silting.

(3) *French drains.* a French drain or French conduit is made of coarse gravel or crushed rock. It can be inexpensive and effective where the amount of water is small. This drain must be protected by a filter or a filter fabric to prevent clogging.

*b. Surface drainage.* Surface drainage provides for the interception, collection, and removal of surface runoff (fig 7-2). Typical examples include shoulders, swales, gutters, ditches, channels, terraces, and dikes; underground pipe and conduits, inlets, manholes, and junction structures; culverts and bridges; drop structures, chutes, energy dissipators, and erosion control structures; detention ponds, infiltration or leaching basins, pumping stations.

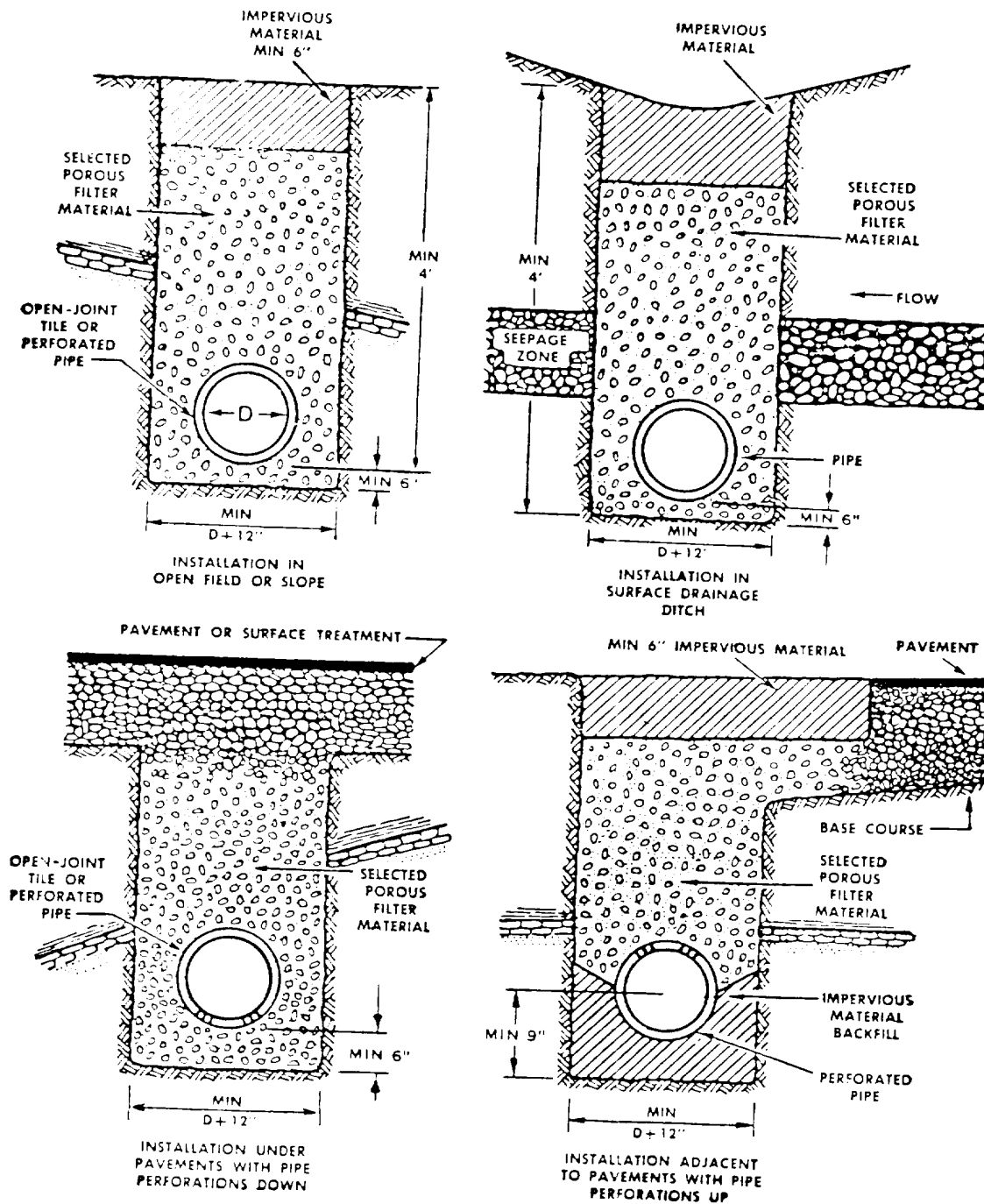


Figure 7-1. Typical subdrain installation.

Properly designed and maintained surface drainage systems may reduce the need for special facilities for control and disposal of ground water.

(1) *Shoulders.* Shoulders receive the water from the roadway and carry it away from the drainage area. Chapter 6 contains more information pertaining to shoulders.

(2) *Ditches and channels.* These are used to carry surface water from drainage areas. The ditches and channels will be of adequate size and type to handle

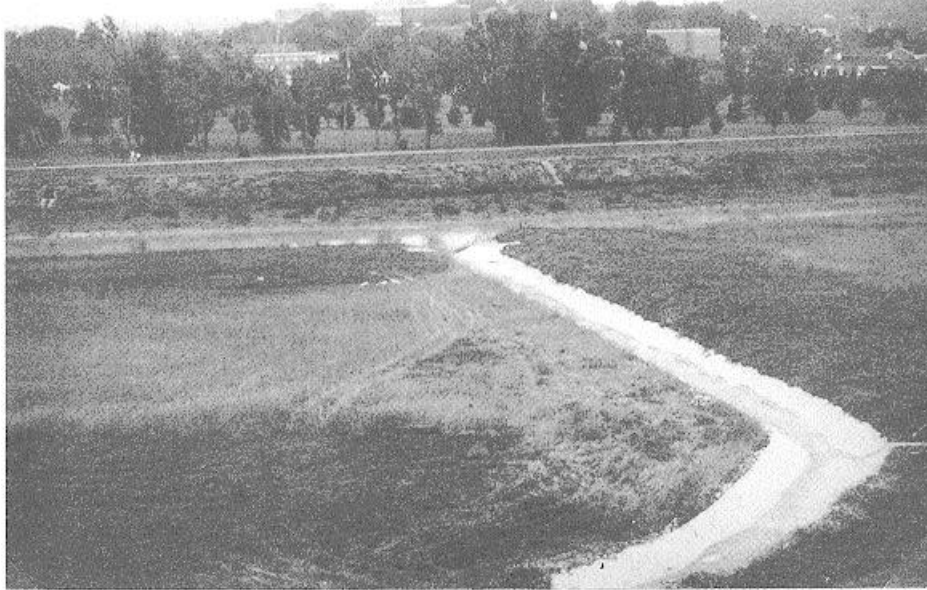
the expected flow conditions. Side inflow will be introduced into a channel at necessary locations rather than randomly along the sides. Terraces and/or levees may be used to prevent side inflow from entering the channel except at desired locations where side channels or pipes are provided to discharge the side flow into the main outfall channel. Flumes will be installed on the surface of steep slopes to carry accumulations of surface water to open ditches or drainage channels (fig 7-3).



They are used to discharge water collected by gutters, berms, or dikes. Flumes will be constructed of various materials including sod, corrugated sheet metal, wood, stone, bituminous hot mix, and concrete.

(3) *Culverts and storm drains.* Culverts and storm drain inlets receive the water from the shoulders, ditches, and channels. Short culverts under sidewalks

may be as small as 6 inches in diameter if they can be kept comparatively free of debris or ice. Pipe diameters or pipe-arch rises will not be less than 12 inches beneath vehicular pavements. The use of larger sizes in lieu of inlet grates or trash racks is recommended for areas subject to windblown debris or for sections greater than 30 feet.



*Figure 7-2. Concrete open drainage ditch.*



*Figure 7-3. Concrete flume for discharging water into drainage channel.*

**7-3. Types and causes of drainage related distress**

Properly constructed and maintained drainage structures can provide satisfactory performance with only minor periodic maintenance. Faulty installation combined with infrequent or improper maintenance will lead to extensive repairs or replacement of pavement structure.

a. *Erosion.* Erosion is the direct result of flowing water, and in any instances it cannot be completely prevented but only controlled. Erosion at culvert outlets is one of the most prevalent problems concerning surface drainage facilities. Two types of channel instability can develop downstream from a culvert and/or storm-drain outlet, i.e., either gully scour or a localized erosion referred to as a scour hole. Distinction between the two conditions and prediction of the type anticipated for a given field condition can be made. A comparison of the original channel is illustrated in figure 7-4. Erosion behind and around the ends of headwalls and endwalls is also a problem. This is particularly evident at multiculvert installations and at single culverts located beneath the low point of roads and streets. Curb inlets and paved chutes could possibly convey flow over a recessed portion in the top and center of such walls, alleviating this erosion and maintenance problem.

(1) *Gully scour.* Gully scour is often a problem at the discharge end of culverts. Gully scour usually begins at a control point downstream where the channel is stable and progresses upstream. If sufficient difference in elevation exists between the out 40 let and the section of stable channel, the outlet structure will be

completely undermined. One of the chief causes of gully scour is the practice of locating outlets at a high elevation relative to a stable downstream grade to reduce quantities of pipe and excavation. The extent of the erosion will depend upon the location of the stable channel section relative to the outlet discharge with respect to both the vertical and horizontal downstream directions. Gully erosion may be prevented or controlled by locating the storm-drain outlets and energy dissipators where the slope of the downstream channel or drainage basin is naturally mild and remains stable under the anticipated velocities; otherwise, the velocity of water will be directed by ditch checks (fig 7-5), drop structures, and/or other means to a point where a naturally stable slope and cross section exist. Outlets and energy dissipators will not be located within channels or drainage basins experiencing disposition. They will be located adjacent to the perimeter and provided with an outlet channel that is skewed rather than perpendicular to the main channel or basin.

(2) *Scour hole.* A scour hole or localized erosion will be experienced downstream of an outlet even if the downstream channel is stable. The severity of damage to be anticipated depends upon the existing conditions at the culvert outlet. In some instances, the extend of the scour hole may be insufficient to produce either instability of the embankment or structural damage to the outlet. However, in many cases, flow conditions produce scour to the extent that embankment erosion as well as structural damage of the apron, endwall, and culvert is evident.

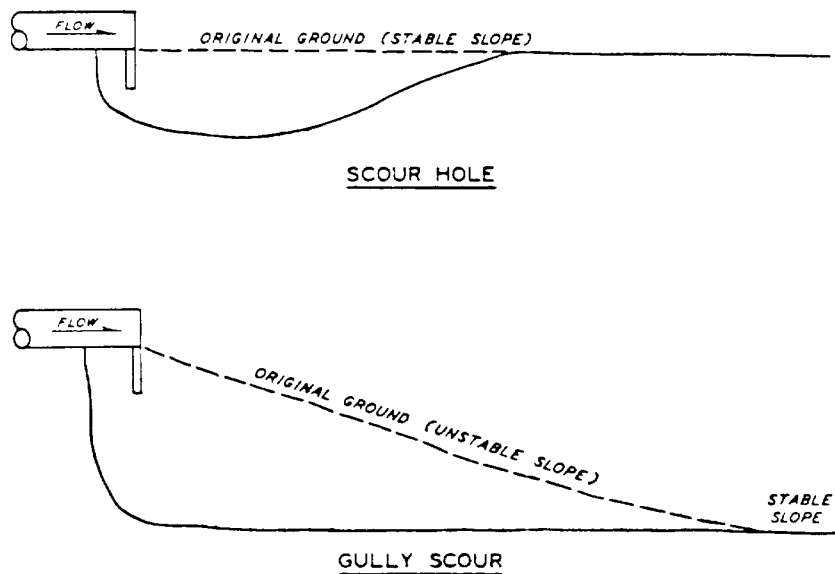


Figure 7-4. Types of scour at culvert outlets.

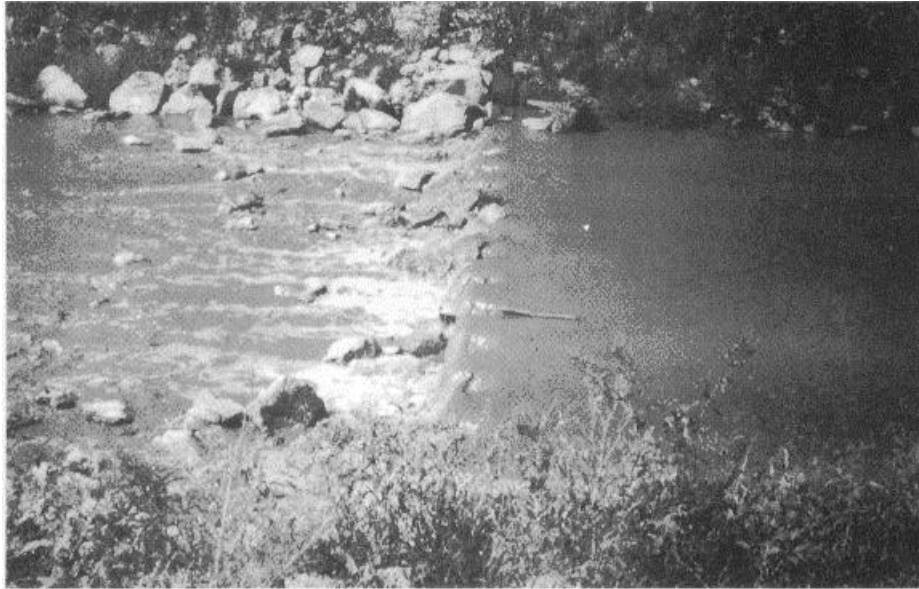


Figure 7-5. Ditch check.

A scour hole will reach a maximum size and then stabilize itself.

*b. Infiltration of soil.* Infiltration of soil is a serious problem, particularly along pipes in relatively steep slopes and those having a broken-back multisloped barrel. Watertight jointing is especially needed in culverts and storm drains under these conditions in order to prevent infiltration and/or leakage and piping. These normally result in the progressive erosion of the embankments and loss of downstream energy dissipators and pipe sections. Cohesionless soils, particularly fine sands and silts, are most susceptible to piping.

*c. Flow obstructions.* Flow obstructions which slow or stop water from draining will cause problems and must be removed. Usually flow obstructions are caused by debris blocking screens, ditches, and culverts. These areas must be inspected after hard rains and any obstructions removed. Some flow obstructions have been built into the system, and the drainage system should be checked and updated for the correct grades, sizes, and types of structures.

*d. Slides.* A slide is caused most commonly by movement of an earth mass down an inclined plane lubricated by seepage of storm runoff or by ground water (fig 7-6). The slippage plane is usually the surface of an impervious soil or rock layer where ground water is collected and trapped. Slides usually result from saturation of steep cuts or fill slopes. They may also result from ground water, frost action, weathering, vibration from blasting, excavation at toe of slope, or other mechanical disturbances. Repair of slides is discussed

in paragraph 6-5c(2).

*e. Construction deficiencies.* Construction deficiencies arise from the original construction either not being built to meet specifications or that the specifications were not sufficient. This type of distress would include structures built on the wrong grade or slope, or sections of a structure not properly placed on relation to each other.

*f. Material deficiencies.* These deficiencies are caused by using an inappropriate or defective material for a job. The use of the wrong gradation for a filter and understrength concrete are two examples of possible material deficiencies.

*g. Depressions and ponding areas.* Depressions and ponding areas cause distress in that they gather and/or hold water. This water can cause skid-resistance and visibility problems, and if it is able to penetrate below the pavement surface, it will damage the subgrade.

#### **7-4. Methods of maintenance and repair of drainage structures**

The methods and criteria for design of surface and subsurface drainage and erosion control facilities are presented in TM 5-820-1, TM 5-8202/AFM 88-5, chapter 2; TM 5-820-3/AFM 88-5, chapter 3; TM 5-820-4/AFM 88-5, chapter 4; and the NAVFAC DM-5. Properly designed drainage, both surface and subsurface, is vital to maintenance and repair of pavements.

*a. Inspection.* A drainage system will be maintained so that it can function efficiently at all times.



Figure 7-6. Slide failure or collapses of a steep slope.

This goal can be obtained through adequate maintenance inspections of the structures, with careful attention to the removal of debris and prevention of erosion. Periodic inspection and evaluation of drainage facilities before, during, and after storms are considered invaluable in identifying problem areas, determining causes of malfunction and/or failures as well as aiding in determining effective methods of maintenance and repair. Periods of dry weather will be utilized in improving the drainage systems and correcting and preventing drainage failures. Any deficiencies in the original drainage system layout will be corrected immediately. Frequency of regular inspections varies with amount and intensity of rainfall and with adequacy and conditions of drainage facilities. As a minimum requirement, a complete inspection will be made in the fall in preparation for the winter season, and another in the spring to determine the extent of repair required. Inspection will also be made after any unusually heavy rainfall. All deficiencies will be noted and reported immediately to the activity engineering department.

*b. Maintenance.* The frequency and degree of maintenance required will vary greatly depending on the type of structure being maintained.

(1) *Mowing.* Periodic mowing of side slopes and adjacent areas of ditches and channels are required for maintaining desirable vegetation cover and control of erosion and carrying capacity. Caution should be exercised during mowing to prevent damage to cleanouts and outlets.

(2) *Cleaning and shaping.* Cleaning and shaping of drainage channels and shoulders are desired for proper drainage. Snow and ice can prevent proper

drainage by blocking drainage structures and impeding flow.

(a) *Drainage channels.* Channels will be provided with side slopes no steeper than 1 on 3. Inverts will be well above the local water table to facilitate easy access and use of conventional maintenance machinery. In areas with high groundwater levels, bottoms of channels may be located 1.5 to 2 feet below the ground-water level to prohibit growth of bottom supported vegetation. Some success has been achieved using composite channels with relatively narrow, shallow paved inverts and grassed side slopes again no steeper than 1 on 3 (1 on 4 preferred when mowing is required). The paved invert conveys low flows with velocities high enough to prevent deposition of fine-grained soil and small debris. The relatively flat-sided slopes are easily mowed and, with proper fertilization, can maintain a stable vegetation cover (fig 7-7).

(b) *Shoulders.* Shoulders will be kept smooth and graded so that water is drained away from the pavement toward the ditch. On a paved or surfaced road, new material will be brought in to replace any shoulder material eroding away. Any unnecessary blading or cutting, in the cleaning and shaping, that destroys the natural ground cover will be avoided. Vegetation will be developed where soil and moisture conditions are suitable, or an appropriate protective cover (ring) will be provided to prevent erosion. Shoulders will be bladed flush to the edge of the pavement to avoid ponding and water seepage into the subgrade. If this is not feasible, outlets will be provided for water obstructed by high shoulders.

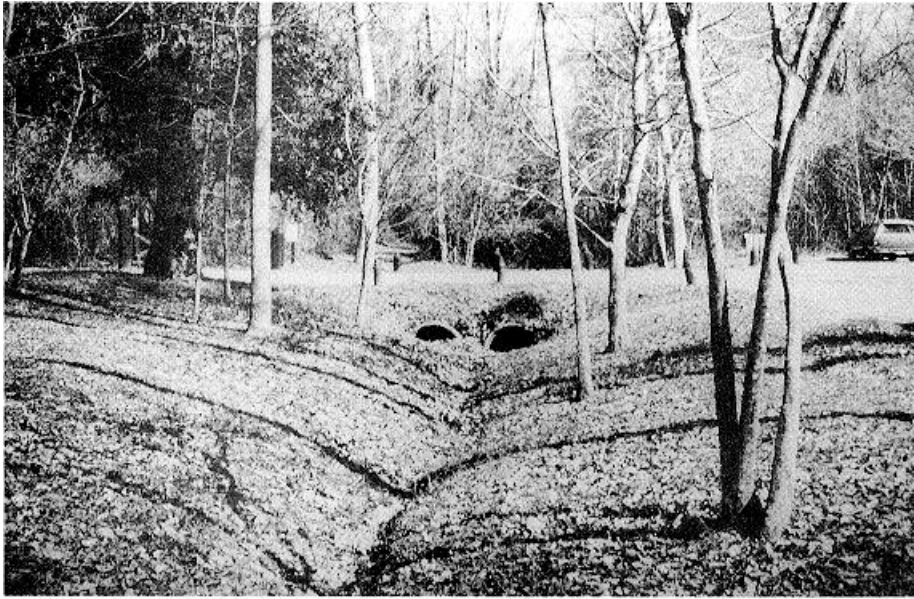


Figure 7-7. Relatively mild side slopes and good vegetative cover.

Stone-filled French drains, normal to or at a downgrade angle from the road or runway, also aid in runoff where heavy precipitation is a seasonal occurrence. Such drains help minimize rutting or washout of shoulders and consequent weakening of pavement edges, thus reducing later repair requirements for materials, labor, and time. Care will be taken to assure that these drains are not blocked with sediment and soil, or they will not function adequately.

(c) *Snow.* If there are accumulations of snow, special attention will be given to drainage maintenance during thaws. Side ditches will be cleared of snow, and channels will be opened through snow accumulations on the shoulder to permit water to escape into the ditches. Every precaution will be taken to prevent meltwater from ponding on pavements, on the shoulders, and in side ditches. Culverts and drains will be kept free of ice and snow.

(3) *Removing deleterious materials.* Deposition of debris and soil in channels are a common problem that notably impairs drainage capacity and requires considerable maintenance. After severe or large volume rains, all drains, culverts, channels, and screens should be inspected and cleaned if debris exists. A blocked culvert or drain can cause problems during a rain and may necessitate immediate cleaning or clearing.

c. *Repair methods.* Various methods are used to repair various structures involved.

(1) *Terraces and levees.* Terraces and levees are used to control water. A failure by these during high water can cause extreme damage. These

structures must be inspected and analyzed for stability against failure and corrected if found deficient. When erosion or slides occur, the structures will be stabilized and repaired immediately.

(2) *Check dams or drop structures.* These devices are used to slow or control the speed of water runoff. The slopes of channel and ditch bottoms will be controlled by rock sills, ditch checks, and/or drop structures. Particular care will be taken to spread waste or spoil removed by channel construction and cleaning operations so that it blends into the local topography and prevents concentration of runoff, which may cause severe erosion and/or sloughing of the side slopes.

(3) *Headwalls and endwalls.* Headwalls prevent severe erosion of scour of the embankment adjacent to culvert inlets; they are particularly advantageous in preventing saturation and seepage of water through embankments, which results in sloughing and piping of the embankment soil (fig 7-8). Headwalls add to or help control flow and also stabilize a fill slope. Endwalls prevent the downstream end of the pipe from being undermined and also protect the embankment as do headwalls from sloughing and piping (fig 7-9). Piping will be minimized by providing proper compaction of fine-grained soils, headwalls, cutoff walls, and watertight joints along the culvert barrel and/or by providing a filter around the outlet on the downstream embankment slope. It is difficult to determine where water will go in areas where vegetation is sparse and terrain is flat. Piping is also relevant to the stability of terraces. It is desirable to provide both headwalls and endwalls on the inlets and outlets of all culverts.

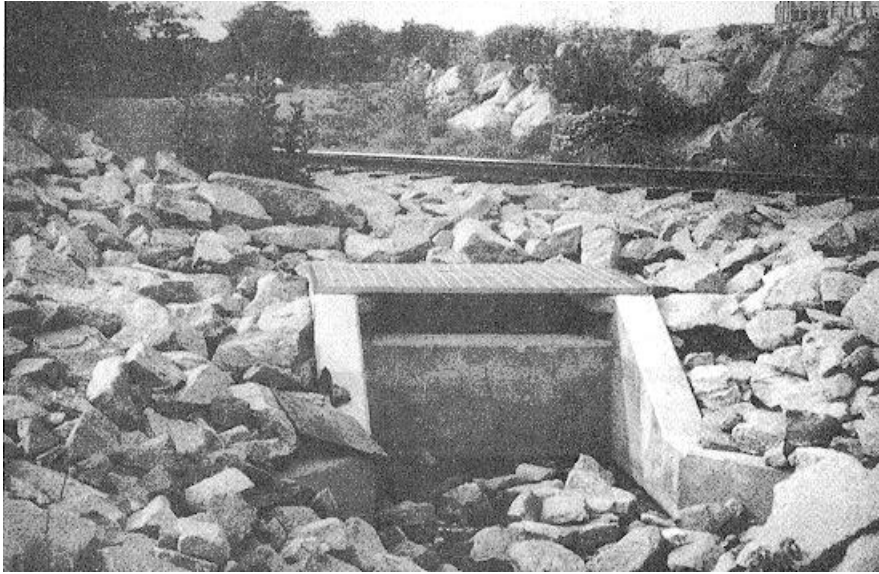


Figure 7-8. Headwall at inlet to culvert passing beneath a railroad bed.

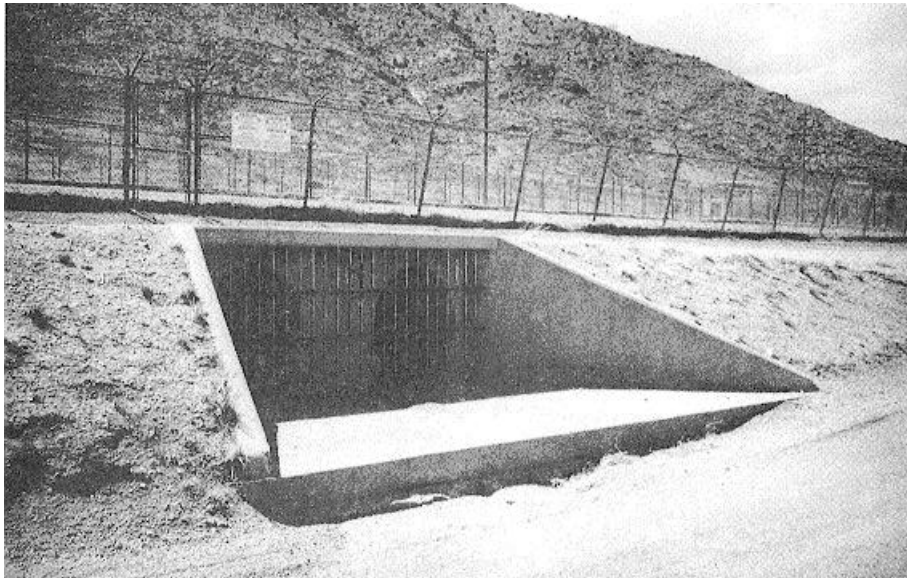


Figure 7-9. Barred concrete endwall for conveying runoff.

(4) *Riprap*. Riprap is randomly placed stones that provide protection against water erosion. Varying degrees of success have been experienced with riprap and/or rubble or other forms of protection downstream of outlets. Different opinions regarding the adequacy of protective stone have been developed. Riprap protection will be provided adjacent to all culverts and structures founded in erodible soils to prevent scour at the ends of the structures. In the placing of riprap, care will be given to selection of an adequate size stone, use of an adequately graded riprap, provision for a filter

blanket, and proper treatment of the end of the riprap blanket. Figure 7-10 presents curves for the selection of the maximum size stone required to protect against the velocities indicated. Two curves are given: one to be used for riprap subject to direct attack or adjacent to hydraulic structures such as side inlets, confluences, and energy dissipators where velocity and turbulence levels are high, and the other for riprap on banks of a straight channel where flows are relatively quiet and parallel to the banks (fig 7-11).

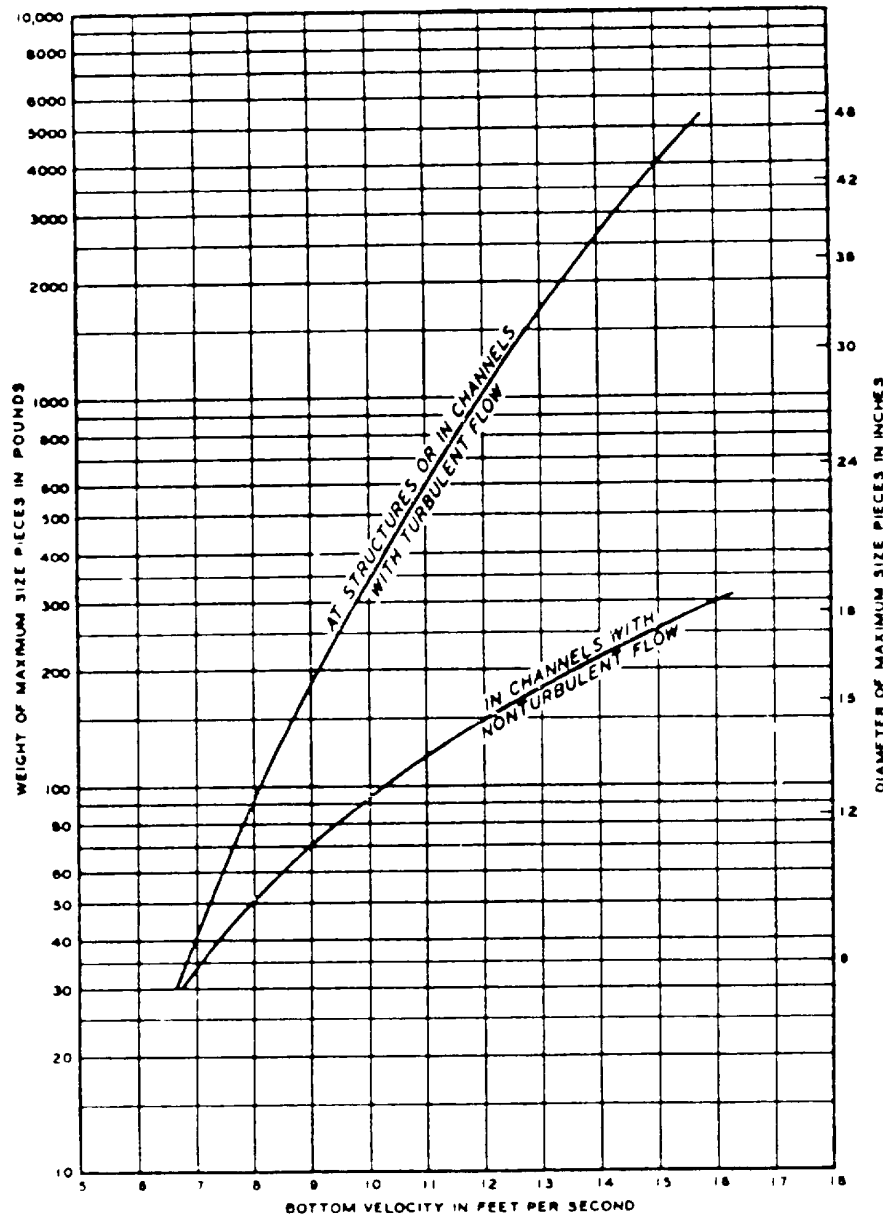


Figure 7-10. Recommended riprap sizes.

The thickness of the riprap blanket will be equal to the longest dimension of the maximum size stone required. Where the use of very large rock would be desirable but impractical, substitution of a grouted section of smaller rock may be appropriate. Grouted riprap will be followed by an ungrouted section. Grouted riprap does not perform satisfactorily in areas subject to repeated freezing and thawing. Whenever grouted riprap is installed, plans will include appropriate filters and weepholes for relief of hydrostatic pressure. Failures to riprap blankets usually result from design deficiencies, especially movement of the individual stones by a combination of velocity and turbulence, movement of the

natural bed material through the riprap resulting in slumping of the blanket, and undercutting and raveling of the riprap by scour at the end of the riprap blanket. Details of solutions to this problem area, in addition to those provided below, are available from appropriate headquarters.

(a) Movement of the individual riprap stone by a combination of velocity and turbulences may be controlled by use of energy dissipators, check dams, and drop structures.

(b) Movement of the natural bed material through the riprap material may result in a slumping failure of the riprap blankets.

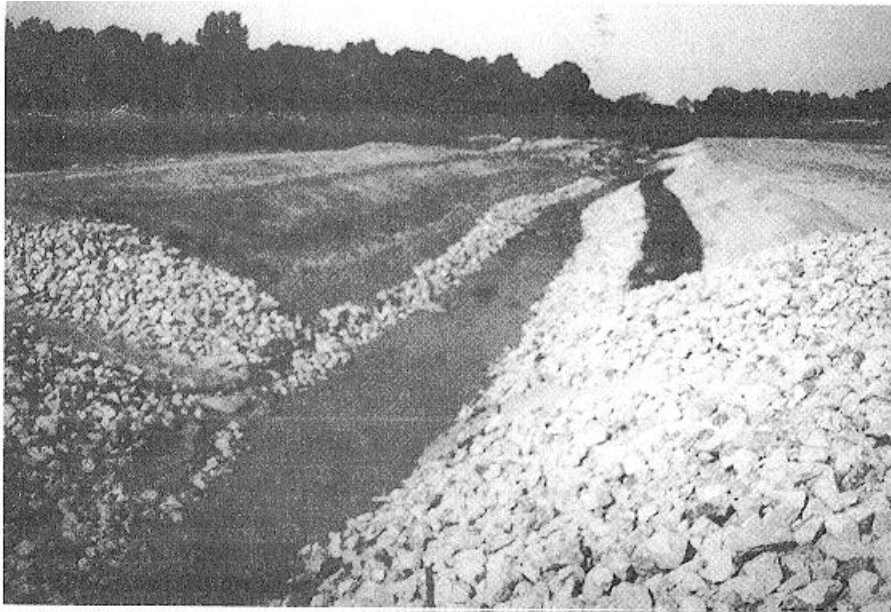


Figure 7-11. Riprap placed along a drainage channel for protection against erosion.

This problem may be controlled by the use of a sand gravel or sand and crushed rock filter or a plastic filter cloth beneath the riprap.

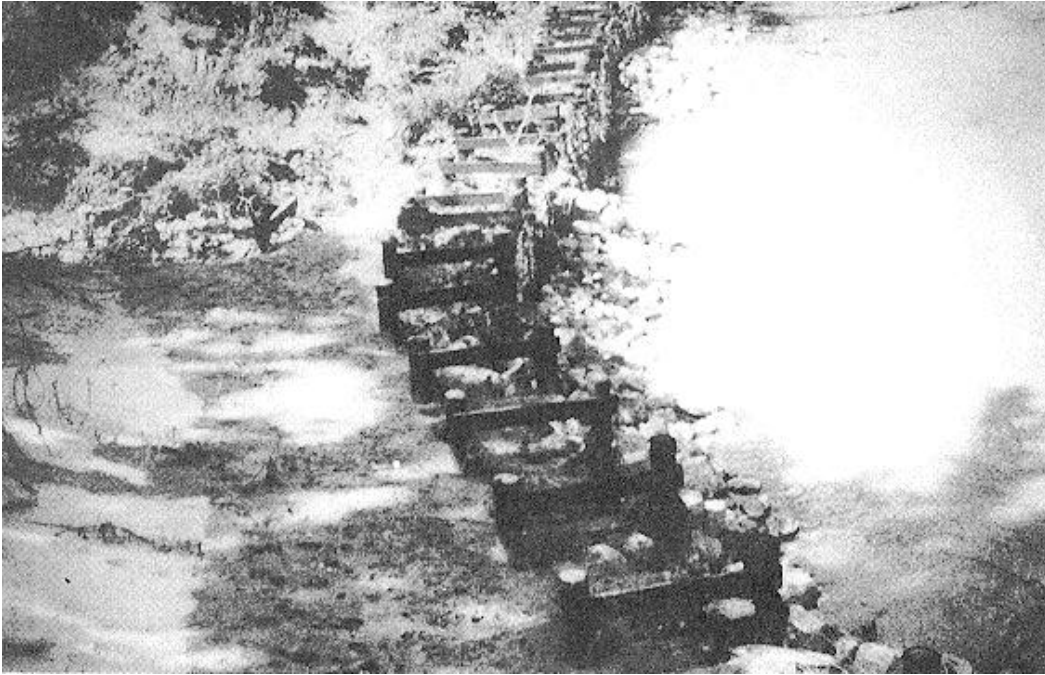
(c) To correct the raveling and scour that develop at the end of the riprap blanket, the thickness of the riprap blanket will be doubled at the downstream end, thereby protecting against undercutting and raveling. An alternative method involves stabilization of a scour hole by providing a constant thickness rubble blanket of suitable length dipping below the natural streambed to the estimated depth of bottom scour.

(5) *Fences*. Meandering channels, excessive sloughing, or bank erosion can be controlled by providing pervious fences of wire, rock, or wood emplaced along the toe of the side slope. Such fences will be properly anchored. The top of the fences will not extend more than 2 or 3 feet above the bottom of the channel (fig 7-12 and 7-13).

(6) *Culverts and inlets*. Culverts and storm drain inlets will be inspected frequently and kept clean of debris, sediment, and vegetation. Debris barriers will be provided upstream of open inlets in areas where debris

and similar materials are present in the drainage basin (fig 7-14). The size and spacing of bars of grated inlets are usually determined by the traffic and safety requirements of the local area; however, it is desirable, in the interest of hydraulic capacity and maintenance requirements, that the opening be made as large as traffic and safety requirements will permit. The provision of a paved apron around the perimeter of a grated inlet is beneficial in preventing differential settlement of the inlet and erosion of the adjacent area; it also makes for easier mowing. Soil infiltration through pipe sections in culverts and drain pipes can be reduced or prevented. Bands or couplings with a 12 inch width are inadequate hydraulically and structurally for joining corrugated metal pipes on slopes steeper than 5 percent. Failures have not occurred where 2-foot bands have been used. The use of appropriate gaskets and couplings of the same width as well as tie bars will be given consideration in joining both rigid and flexible pipes on steep slopes. The use of durable synthetic cloth filters around the joints will be considered to aid in preventing soil infiltration through pip joints. Low pressure grouting is also available for filling voids behind pipes.

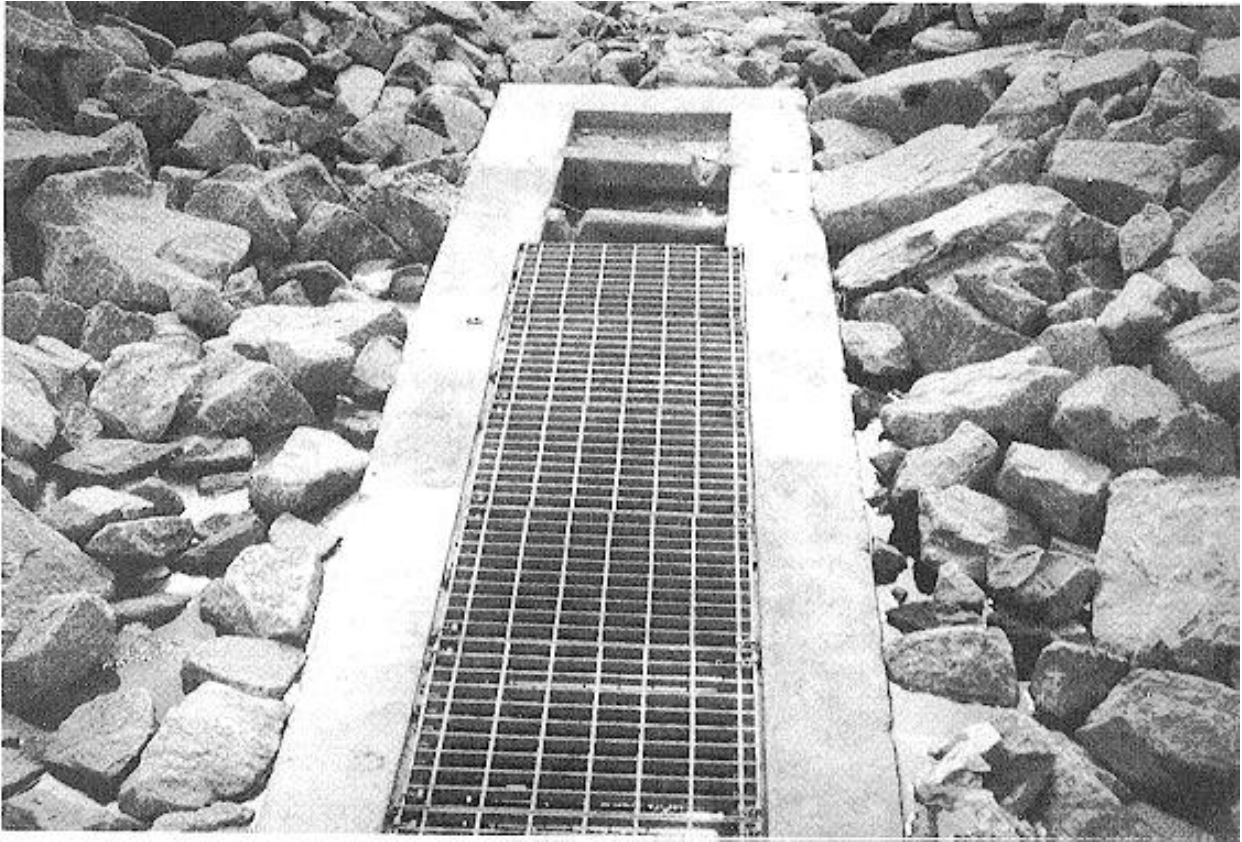




*Figure 7-12. Wood and rock fencing for control of erosion.*



*Figure 7-13. Rock fences for control of erosion.*



*Figure 7-14. Grated inlet.*

---

**MAINTENANCE AND REPAIR OF BRIDGE SURFACES**


---

**8-1. Introduction**

There are many types and sizes of bridges on military installations. These range from single-span untreated timber bridges to multiple-span steel and concrete bridges. This section deals mainly with the maintenance of various types of pavement surfaces common to bridge structures predominant on military installations.

**8-2. Types of bridge surfaces**

The type of bridge and bridge surface used should be tailored to the traffic it will receive. The parapets or siderails should provide for safety considerations while also providing an avenue for snow, dirt, or other deleterious material to be removed.

*a. Timber.* Bridges have the entire buildup of the roadway constructed of wood. A bituminous wearing surface will be provided on all laminated timber floors to reduce wear and prolong life. The bituminous wearing surfaces on the various types of timber floors will be properly maintained in smooth condition. Surface roughness induces excessive vibration which causes timbers to work loose and wear rapidly. Holes in wearing surface will be patched promptly.

*b. Steel.* Steel surfaces are in the form of metal grating. These surfaces are seldom used due to their original cost, required maintenance, and slippery surface when wet.

*c. Asphalt.* Many types of bridges have asphalt pavements. Details on maintenance and repair of asphalt pavements are contained in chapter 3 of this manual.

*d. Concrete.* Concrete slabs and/or overlays are widely used as bridge surfaces. Chapter 4 of this manual contains details on maintenance and repair of concrete pavements.

*e. Miscellaneous.* Miscellaneous surfaces would include pavement surfaces constructed with tars and epoxies. These surfaces have limited application and are normally used only under specific circumstances. Epoxies have had some use as patching materials, especially on concrete pavements.

**8-3. Types and causes of bridge surface distress**

Distress to the roadway can be caused by deterioration or movement of the bridge structure. These bridge distresses must be corrected before the roadway can be restored.

*a. Asphalt pavements.* Chapter 3 covers the types and causes of distress in asphalt pavements.

Bridges present special problems in that the pavement is subjected to more rapid changes in temperature resulting in greater expansion and contraction.

*b. Concrete pavements.* Factors causing deterioration in concrete slabs and decks are freezing, thawing, salt action, temperature variations that set up severe differential stresses and strains within the concrete mass, and unsound aggregates that are vulnerable to weathering from moisture and freezing. Leaching (water seeping through cracks and voids dissolving the calcium hydroxide) will also cause deterioration. Wear and abrasion from traffic, foundation movements, and shrinkage and flexure forces that set up tensile stresses will cause cracking and deterioration. Where road salts are used, these can work their way through the concrete cracks and corrode the reinforcing steel (fig 8-1).

**8-4. Methods for maintenance and repair of bridge surfaces**

*a. Inspection* Alignments of handrails and floor and gutter profiles will be checked for any unusual movements that might have occurred. The roadway surface will be checked and patched, where needed, to maintain a smooth riding surface. The roadway drains, outlets, and expansion joints will be cleaned and any maintenance necessary for their good working condition will be accomplished.

*b. Maintenance.* The following are general maintenance requirements which must be performed periodically depending on the type of bridge involved. Fouled expansion joints will be cleaned and freed. Bearing plates will be cleaned and greased so that all moving parts are in free operating condition. Handrails will be checked for alignment or cracking. Misalignment or cracking indicates settlement or movement of the structure has occurred. If major repairs to piers, footings, and general structure are necessary, the repairs will be supervised by a competent bridge engineer. If leakage infiltrates cracks or joints, they will be cleaned and filled with the proper sealant (see chap 3 or 4, depending on the type of surface).

*c. Repair methods.*

(1) *Timber repair.* Floor planks will be laid with the heart side down because it is more resistant to decay. In order to have a good drainage and air circulation and to provide for expansion, a V4-inch spacing will be provided between planks. Structural grade hardwood planks 6 to 10 inches wide are preferred because wider planks have a tendency to curl. All spikes will be driven so that their heads are

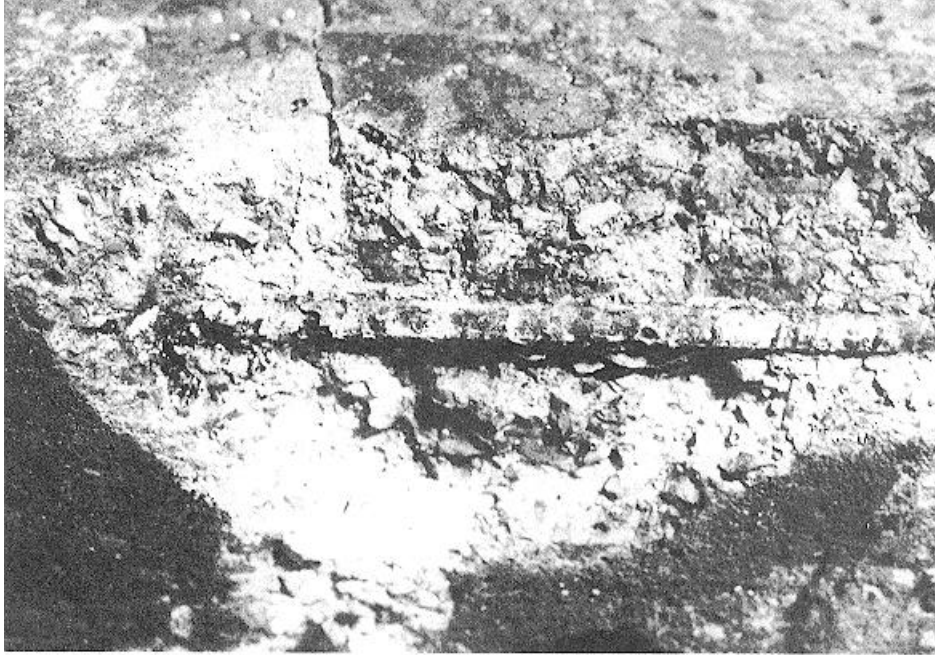


Figure 8-1. Exposed reinforced steel.

imbedded into the plank. The flooring planks of the same thickness will be placed adjacent to each other with a full, even bearing on the stringers. Shims or wedges will not be used to level flooring because they are easily dislodged and leave the flooring in a loose uneven condition.

(a) *Wheel guards.* In repairing wheel guards, use the same size sections as in the original structure and fasten with the same bolt spacing. The bolts will be extended through the riser or scupper blocks and floor planks.

(b) *Handrails.* Handrails will be replaced with new bolts and knee braces where needed. Handrails will be painted after repair with three

coats of durable, highly visible outside paint.

(2) *Patching.* Patching will usually involve any one of three materials: asphalt, concrete, or epoxy. The patching procedures for asphalt and concrete are found in chapters 3 and 4 of this manual. There are many different types of epoxy materials available for repairs. They will be used to repair concrete pavements and only used on asphalt surfaces in emergencies because any rigid patch material does not do as well on asphalt as a flexible patch material. Epoxies are very temperature dependent; they take longer to cure in cool and overcast weather. Epoxies are recommended where traffic is necessary on the patched area within a few hours patching.

**9-1. Trafficked area requirements**

The requirements of trafficked areas will vary with the type and amount of traffic. The following paragraphs highlight the requirements of several types of traffic application areas.

*a. Roads.* Wheeled vehicles are impeded by snow and ice on roads, depths approaching 25 percent of the wheel diameter can immobilize a vehicle. Gasoline consumption is increased slightly when tires pass over rutted compacted snow surfaces, by 10 percent when driving through 1 inch of new snow, and by 15 percent through 2 inches of new snow. The coefficient of friction of tires on ice is less than 0.1 near the melting point, and on compacted snow increases to around 0.25, compared to dry pavement values of 0.8 to 1.0 on PCC or AC. In addition to roads, snow can obstruct parking lots, storage areas, railroads, and sidewalks. Therefore, in the interest of safety, mobility and reduction in the costs of operation, snow should be cleared from pavements and ice should be treated or removed. The degree to which these services should be performed will depend on maintenance standards established at the particular location.

*b. Runways and heliports.* The presence of shallow snow on a runway in itself does not pose a serious hazard to takeoff and landing operations of aircraft. Compacted snow runways have been constructed and used in Alaska, Greenland, and the Antarctic and are adequate for light and heavy aircraft. Hazards arise from three sources.

(1) A completely ice-covered runway which will greatly decrease traction and braking capability.

(2) The occurrence of patches of snow or ice on a runway which may give rise to differential braking.

(3) The presence of slush which can build up on the underside of an aircraft during the take-off roll which can impair aerodynamic efficiency and increase the take-off weight above the acceptable maximum. Loose dry snow is not a hazard in itself, but fixed wing aircraft, and in particular helicopters, can raise clouds of snow which may seriously impair visibility. For these reasons, it is standard practice to remove all snow from hard-surfaced runways by blading and/or sweeping with a rotary power broom.

*c. Encampments.* Expedient construction of roads by compaction of snow is practicable in areas where infrequent thaws occur during the winter. Rollers made of corrugated metal pipe and dragged by a tracked vehicle are generally used. This method

makes unnecessary the removal of snow, but as more snow accumulates, it must be rolled in place. Ruts, washboard patterns, and drifts are eliminated either by dragging or blading with a bulldozer or grader blade and again rolling. Dry snow churned by wheeled or tracked vehicles becomes sand-like in its consistency and should be bladed off to improve traction.

**9-2. Properties of snow and ice**

The properties of snow and ice are affected by the conditions under which they were formed. The various conditions include the temperature of the air and the pavement surface, and moisture available in the air.

*a. Snow.* The thermal and mechanical properties which affect snow removal vary considerably. There are initial differences of snow type controlled by the meteorological conditions prevailing at time of deposition, and further changes result from mechanical and thermal metamorphism subsequent to deposition.

(1) *Density.* Snow density (the mass per unit volume) ranges from less than 6.2 p.c.f. to more than 25 p.c.f. when the snow is dry and undisturbed by traffic. Density is an important index of snow type. Combined with the depth of a snowfall, it is an indicator of the magnitude of a snow removal task. It is measured in the field by weighing a sample of known volume.

(2) *Strength.* Snow strength is dependent on the grain structure and temperature. The grain structure is related to the density of the deposit and the degree of bonding between adjacent grains. It is important to remember that snow strength increases as density increases, age increases, and temperature decreases.

(3) *Energy of disaggregation.* Energy of disaggregation is the work which must be done on a cohesive snow mass in order to pulverize it (by breaking intergranular bonds), and it therefore gives a measure of one energy requirement for a plow. There is a close correlation between rupture strength and energy of disaggregation for dry, bonded snow.

(4) *Water content.* At 32 degrees F liquid water is held in the snow by surface tension. Wet snow tends to adhere to plows and presents rotary plows with different demands than does dry snow. For example, a rotary plow working on light fluffy snow is virtually blowing air; one working on dense dry snow is milling a brittle solid and blowing a mixture of air and ice particles; a plow churning very wet

snow comes close to pumping water. Water content is usually measured by calorimetry in the laboratory. There are no simple and reliable field methods for water content determination currently available. A relative indication is given by making and squeezing snowballs. Cold dry snow will not form snowballs at all while very wet snow from which water can be squeezed will make snowballs. When snow has such a high water content that it takes on fluid properties (e.g. flowing and splashing), it is referred to as slush.

*b. Ice.* The method with which ice forms will affect its adhesion to the pavement surface and the degree of difficulty involved in its removal.

(1) *Ice formation.* Rain falling on a cold surface and flowing prior to freezing results in a smooth glare, or glaze, ice layer. It appears clear or slightly milky if some air bubbles are frozen in. Glaze ice is tightly bonded to the pavement. If the water droplets striking a cold surface are supercooled, freezing can take place almost instantaneously before any flowing can occur, and the rime ice that results is not tightly bonded to the surface. The large volume of air voids in this type of ice gives it a white appearance. Moisture that condenses on a cold pavement and flows prior to freezing ("black ice") is as well-bonded to the pavement as glaze ice but is generally much thinner. This type of ice forms in some localities particularly in the spring where radiation cooling and calm winds contribute. Ground water or melt water ponded on or flowing over a pavement and subsequently freezing may not be tightly bonded initially if freezing occurs from the atmospheric side. However, if thin sheets of water flow over a cold pavement and freeze from the pavement side, the ice that forms may be glaze ice. Snow which has been compacted by traffic and undergone several freeze-thaw cycles may not have the appearance of ice formed by the mechanisms described above. However, it may be much thicker and uneven and pose more of a hazard to traffic and more of a problem to remove than the other types of ice.

(2) *Factors affecting ice formation.* The air, precipitation, and pavement surface temperature all determine the type of ice that may form. Pavement surface temperature is influenced by solar radiation, the reflectivity of the surface, the specific heat and thermal conductivity of the pavement and subgrade, and the heat content of the underlying soil. Surface temperature can vary considerably along a pavement, and thereby affect the ice formation potential. Subgrade insulation will increase the rate at which a pavement cools because heat flow from the subgrade is interrupted, and therefore, ice may form preferentially early in the winter on insulated pavements in contrast to an uninsulated pave

ment. The situation will be reversed in the spring, however, when the pavement will warm more rapidly if insulation reduces the heat loss to the cold soil below. Bridge decks will respond in a similar manner, cooling rapidly in the fall and warming quickly in the spring. Surface temperature fluctuations are more likely to occur during the winter than on other pavements.

### 9-3. Equipment for snow and ice control

The equipment for snow and ice control can be broken down into either mechanical or chemical treatment processes. The following paragraphs discuss equipment for both types of treatment.

*a. Blade plows.* Blade plows, also called displacement plows, are mounted on the front of a vehicle and push the snow in a direction at a right angle to the vehicle movement. A one-way blade casts snow in only one direction, generally to the right in those countries with right-hand traffic. A reversible blade (fig 9-1) permits adjustment of the plow for either left or right cast. A V-blade plow casts snow to the right and left simultaneously. Blades are generally mounted on trucks, from V4-ton utility vehicles to 54, 00 pounds GVW units. Graders (motor patrols) are used with either a moldboard alone or with a front-mounted displacement blade. The snow speed of graders reduces their utility in many situations; however, they have been used very effectively for cleanup. Blades can be mounted to the underside of trucks either for applying down pressure for ice removal or for removal of a thin snow cover. Trailing or tailgate blades are used to prevent a cloud of snow from flying in front of the vehicle and obscuring the driver's vision. Side or wing plows are used to extend the plowing width or to cut down high banks or windrows at the side of a road ("high winging").

*b. Rotary plows.* Rotary plows use one or more rotating elements to break the snow from a continuous cover and to cast it to one side through a directional chute. Single-element rotary plows use one rotary device to break up the snow and to cast it through a chute to one side. Two-element rotary plows (fig 9-2) use separate means of these two functions, either horizontal-axis helical augers or helical open-ribbon cutters for disaggregating the snow and feeding it to a paddle wheel impeller for casting through a chute. Rotary plows can be damaged by ingestion of debris such as rocks, branches, tools, and similar foreign objects; therefore, care must be exercised in preventing such accumulation on pavements routinely cleared of snow.

*c. Snow loaders.* Rotary plows and front-end loaders are most commonly used to load snow into trucks for hauling to a disposal area, but specialized



*Figure 9-1. Reversible blade mounted on a 1/4-ton utility truck.*



Figure 9-2. Two-element rotary plow with twin horizontal-axis helical augers.

equipment is also available. The conveyor-type equipment (fig 9-3) gathers the windrowed snow into a collecting box by means of an open helical auger, then rake feeds it to a continuous conveyor belt for lifting into a following tank.

*d. Sweepers.* Light snowfall, and residue following plowing operations can be removed by power rotary brooms. A high-volume low-pressure airblast at grazing incidence to the pavement assists in cleaning the residue on airfield-type units (fig 9-4).

*e. Sidewalk plows.* Road equipment is both too large and too heavy for use in clearing sidewalks or other narrow passageways such as are found in warehouse or hanger areas. For this purpose a small tracked vehicle equipped with a rotary plow or a V-blade can be used effectively (fig 9-5).

*f. Rollers and drags.* These are not true pieces of snow removal equipment, but rather, devices for constructing or maintaining compacted snow roads in areas of prolonged, uninterrupted cold. Rollers, made commonly of corrugated metal pipe, compact the snow, and drags are used to scarify surface irregularities prior to rolling.

*g. Solid material applicators.* Solid materials are normally applied with tailgate spreaders. The spreader can be either a spinning disk or a roller running the full width of the tailgate. The applicator shall have the means of achieving positive control of the application rate.

*h. Liquid material applicators.* Liquid materials are normally dispensed by conventional nozzle distributor bars attached to a suitable tank vehicle.

Bituminous distributor trucks are often acceptable for

applying the materials. The equipment used shall have a pump and sprayer capable of providing positive control of application.

*i. Combination applicators.* Vehicles containing both mechanical spreaders and spray equipment to combine solid and liquid materials are used. The liquid material is usually sprayed onto the solid material as the solid material is spread. The pump is driven by the spreader drive shaft providing positive control and proportioning between the liquid and solid materials as applied (fig 9-6).

#### 9-4. Snow control and removal

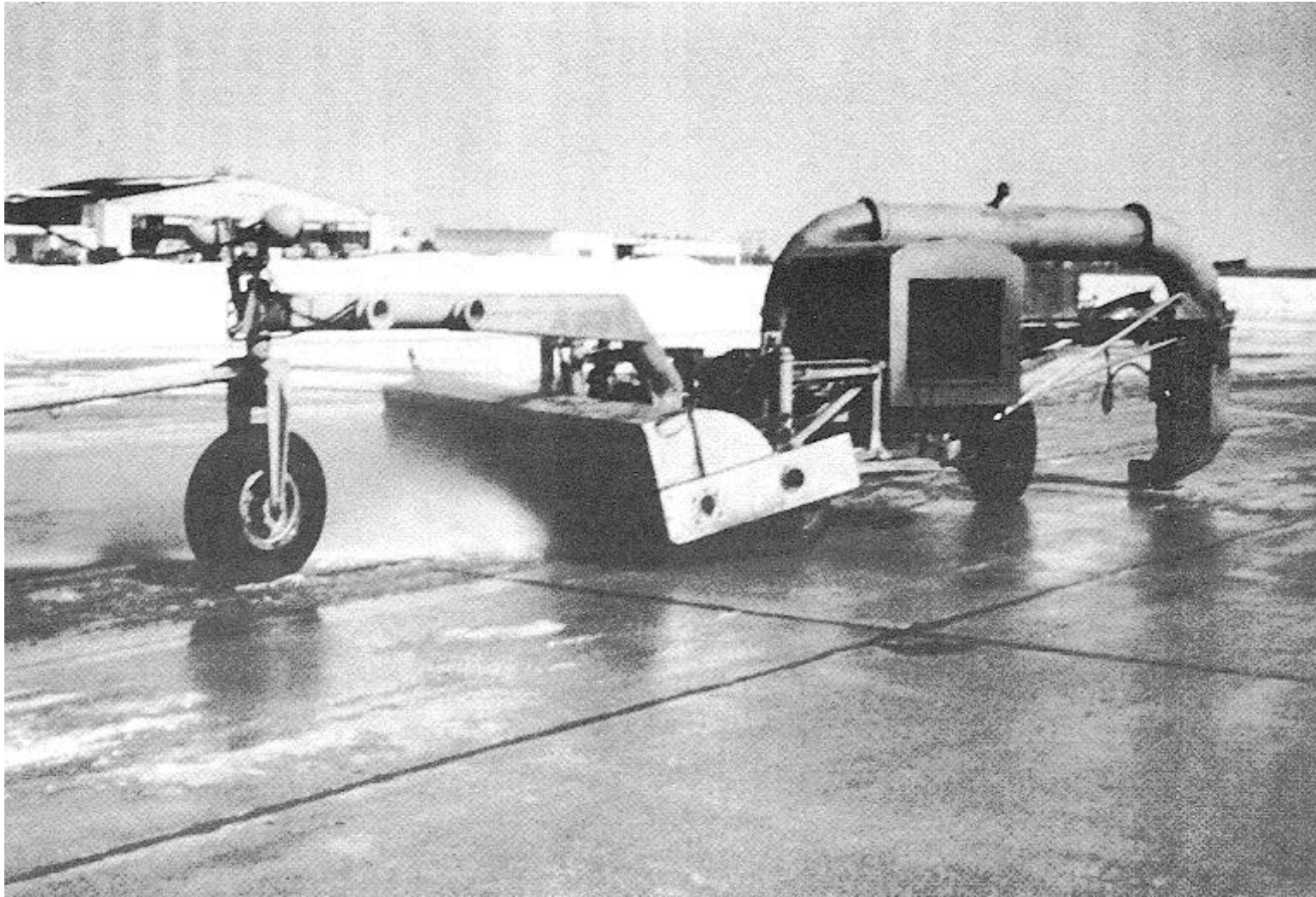
The expense and time involved in removing snow from a road or runway can be minimized by eliminating obstacles which cause drifting to occur across the pavement. These areas can be kept snowfree or by providing a designed obstacle, properly placed with respect to the area to be protected, which will trap the snow or cause it to accumulate in an acceptable location.

*a. Snowdrifting characteristics.* Snow particles carried by the wind can come either from new precipitation falling during a storm or from particles which were previously deposited on the surface and later picked up by the wind. Drifting during snowfalls can occur even with very low wind speeds, but appreciably higher speeds are required to pick up snow already deposited and carry it along. If the snow is loose and unbonded, speeds of 7 to 18 miles per hour can lift and transport snow, but if the





*Figure 9-3. Belt conveyor unit for truck loading snow.*



*Figure 9-4. Towed power rotary broom with high-volume low-pressure airblast.*



*Figure 9-5. Small tracked vehicle with V-blade towing a sand spreader*

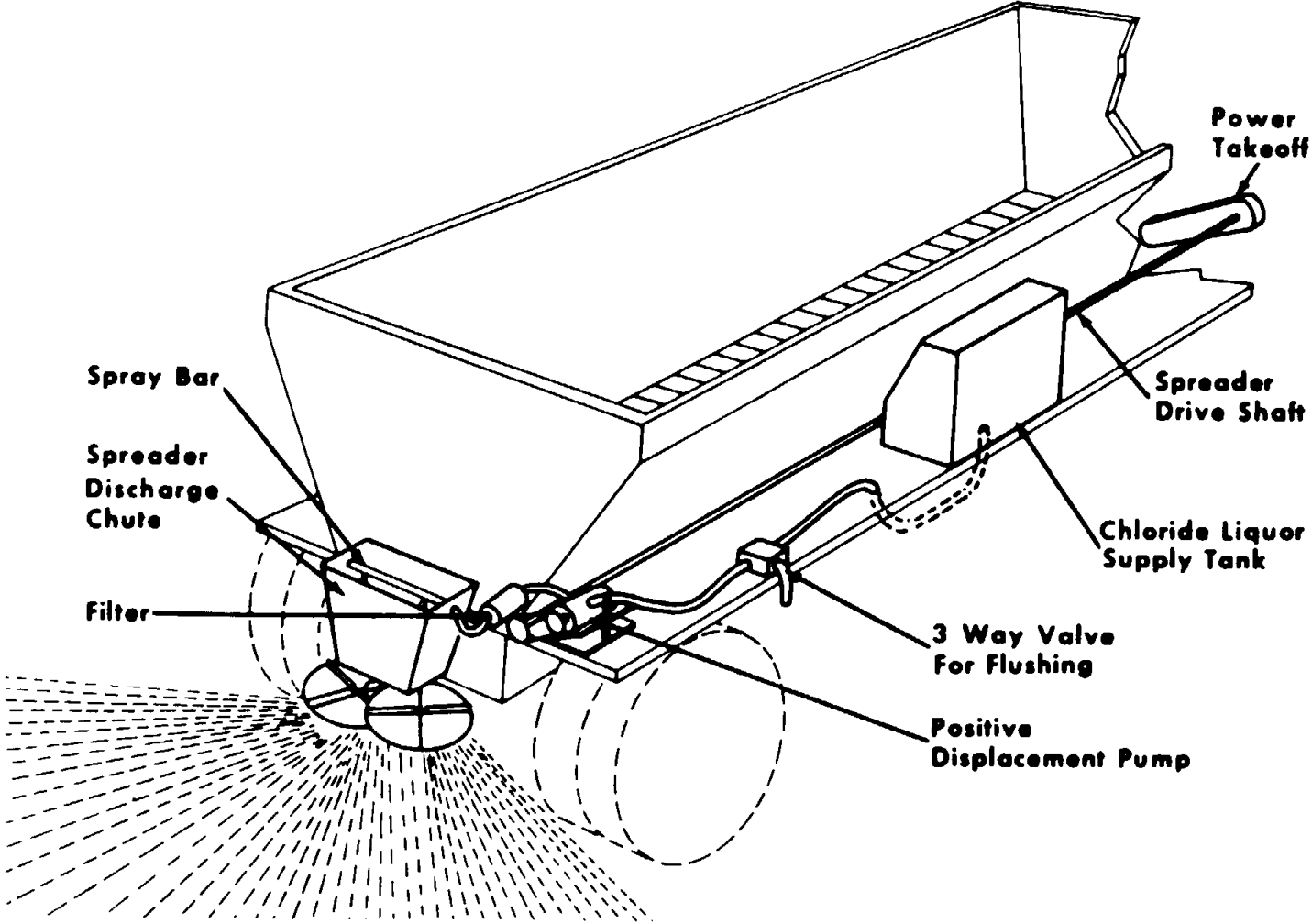


Figure 9-6. Combination applicator

surface is densely packed and firmly bonded by freeze-thawing or age hardening, winds as high as 65 miles per hour may be required for transport.

*b. Snow fences.* Snow will remain in suspension by turbulent diffusion as long as the wind speed remains above a threshold value. When a change in topography occurs, either a projection above the average surface or a depression below it, eddy currents will develop in which the speed will be reduced below the threshold value and the snow will drop out of the wind stream (fig 9-7). This can occur around buildings or other solid structures as well as on roads built in cuts. Snow fences will store snow for a distance of 10 to 35 times the height of the fence (fig 9-8). Therefore, the fences should generally be placed a minimum of 20 times their height from the area to be protected. A fence will store a limited amount of snow, and when saturated, offers no further protection. For this reason, in regions of frequent drifting snow conditions and few periods of melt, high fences (up to 12 feet) or multiple rows are used or a new fence must be installed on top of the drift that has formed. Typically one tall fence is better than two smaller fences. Fences are most effective when they face broadside into the wind, and arrangements for protecting a road section from winds of different approaches are shown in figure 9-9. Temporary fences will be installed in the fall prior to freezing of the ground and before major snowfalls are expected. In the spring they will be removed, inspected, repaired, or replaced if necessary, and stored in a dry location.

(1) *General.* The common type of snow fence serves as a collector to form a drift upwind of the

area to be protected. Studies have shown that a fence of 40 to 50 percent density (i.e., the solid space occupied by the fence material as a fraction of the total frontal area along the fence) and with a gap of 0.1 times the height between the fence bottom and the ground is most advantageous. Within these ranges, the greater the gap, the further the drift is displaced from the fence, but collection efficiency essentially remains constant. The influence of fence density is shown in figure 9-8 where it is evident that the maximum snow volume collected lies between the 42 and 50 percent fence densities. Fence height also influences collected volume (the higher the fence, the greater the volume).

(2) *Artificial fences.* The familiar vertical wood slat fence (fig 9-10) is 4 feet high; the slats are 1 1/2 by 1/2 inch with 2 inch openings, thus giving a density of 43 percent. Its bulk and weight of 1.6 pound per running foot have led to the development of alternative materials such as plastic strips attached to posts by stapling or clamping, and plastic woven material (fig 9-11). Other fence designs, some of an expedient type, are shown in figures 9-12 through 9-15. Regardless of the construction material or method, the goal is to reduce the windspeed and allow the snow to drop out of the airstream before it reaches a location requiring protection.

(3) *Plant fences.* Rows of trees and shrubs forming shelterbelts are used as living fences in areas where permanent protection is required and land is available for their growth. An example of a typical shelterbelt is shown in figure 9-16, consisting of a row of low shrubs and two rows of trees. Distance between rows is 10 to 12 feet, spacing of

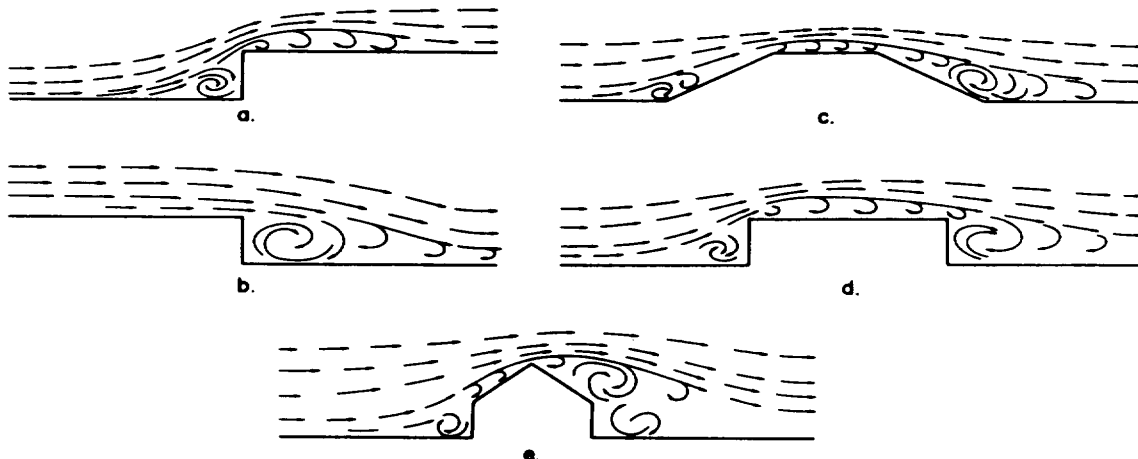


Figure 9-7. Simplified impression of eddies formed by typical obstructions.

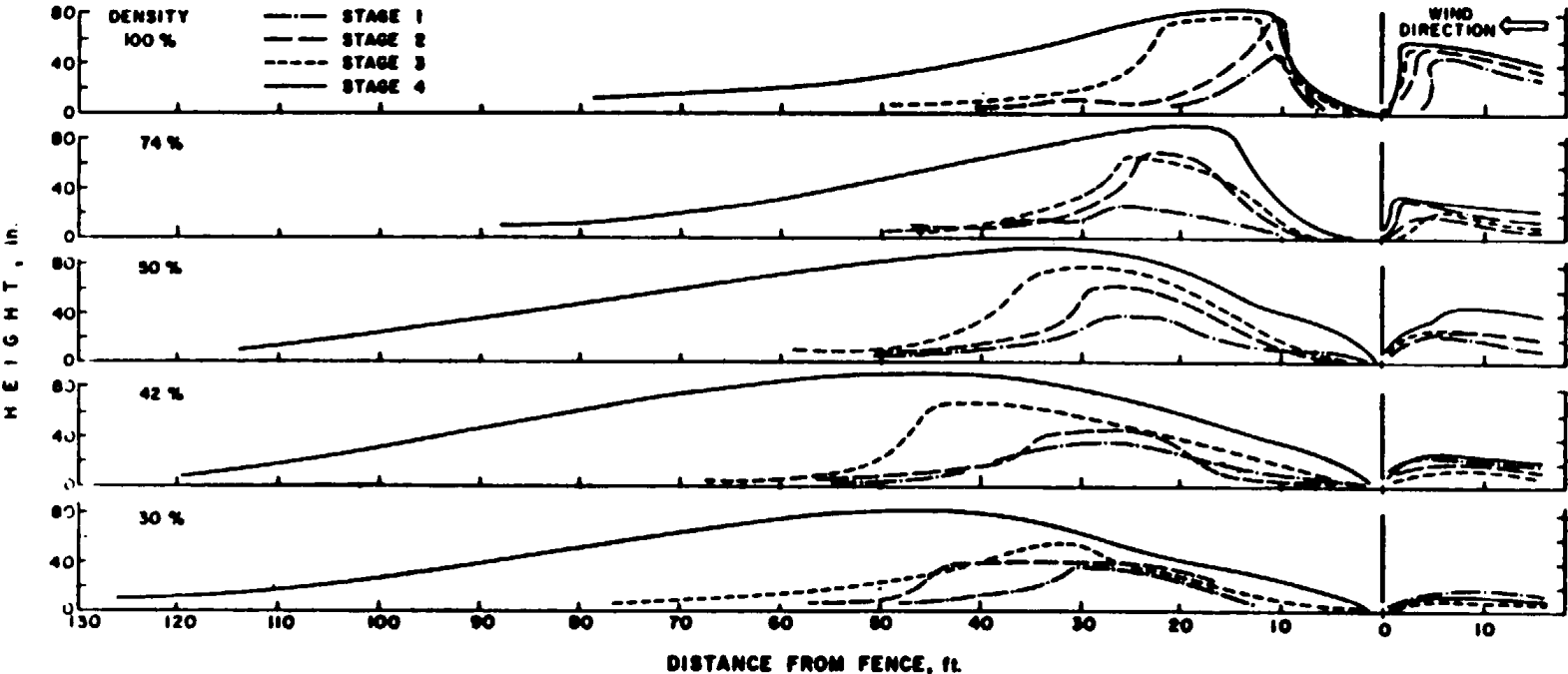


Figure 9-8. Snowdrifts generated by solid snow fences and by vertical slant fences of various densities.

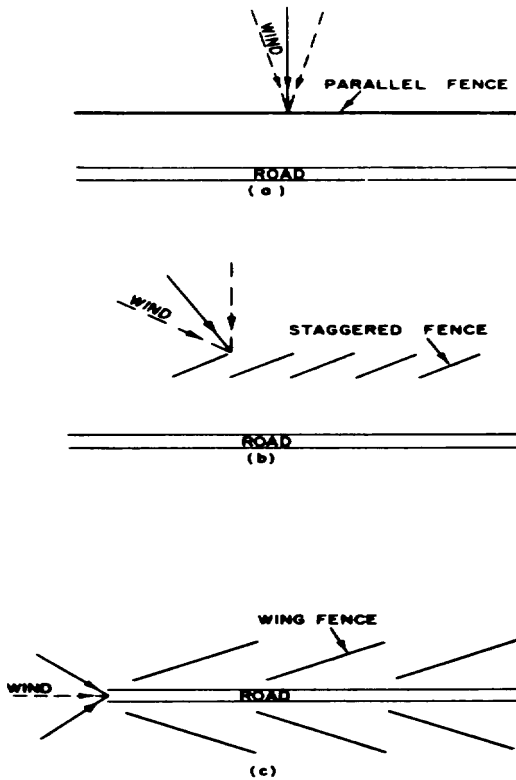


Figure 9-9. Basic arrangements of snow fences for protecting roads or railroads.

the shrubs is 3 feet, and tree spacing in its rows is 6 to 8 feet. A multiple row shelterbelt is much more effective than a single row because of the number of gaps that occur in a single row.

(4) *Snow pile fences.* An expedient protection method utilizes a series of plow cuts in the snow cover to build a windrow of snow to act as a fence. The height and resulting coverage can be extended by repeated plowings.

c. *Road snow removal.* Blade plows are dispatched to plow along routes laid out in a snow removal plan. In making routing assignments, consideration must be given to such factors as grade, width, surface condition of pavement, traffic density, level of maintenance required, occurrence of parked cars, storage space available for the plowed snow on or off the road, shoulder width, and speed limitations when plowing. Also, factors expecting

average snow accumulation rate, incidence of wind, and its expected speed and direction must be considered. These factors can be used to determine the frequency of plow passes and the number of pieces of equipment required. On rural-type roads higher truck speeds may be possible, resulting in snow cast well off the road and many miles of coverage. In built-up base areas, parked cars, traffic, curbs, street furniture, and buildings limit both plowing speed and snow storage space, frequently making necessary truck hauling of snow to disposal area.

(1) *Chemical application.* As soon as snow begins falling, equipment should be dispatched over the high priority routes. At temperatures above 20 degrees F and when the weather forecast does not indicate temperatures falling below that level, a light application of salt (sodium chloride) should be made at the rate of 250 pounds per mile (based on a 12-foot wide pavement) to prevent formation of a tight adhesive bond between the snow and the pavement and increase the clearing effectiveness of the plows. Plowing and chemical application can be accomplished simultaneously.

(2) *Coordination.* Plows should not be routed to oppose traffic flow. Echelon plowing is recommended on wide pavements to avoid leaving a windrow on the traveled way between plow passes. However, shoulder clearance can be postponed until the end of a storm, but it is essential that sufficient storage be provided for the next storm by winging back the windrows alongside the road. On divided highways the plow team can cast snow into the median if there is sufficient storage space as well as to the right shoulder. Intersections require particular attention to reduce the windrows left across the road crossing at a right angle to the truck direction.

d. *Airfield snow removal.* Snow removal must be given priority over aircraft operations on the runways when snow conditions would jeopardize their serviceability and cause the installation to be closed to flying. To do this, close coordination and cooperation must be maintained between snow control and airfield management. Alternate access to the runway by snow and ice control equipment as well as by aircraft is necessary so that airfields are in operational condition at all times. Successful snow removal will depend largely upon the initiative and common sense of the personnel concerned.

(1) *When to start snow removal operations.* Current requirements prevent waiting for weather to improve before starting snow or ice clearing operations. While a variety of techniques are still required to clear snow of various debts from lower priority airfields and other areas, snow clearing on top priority airfield areas must commence with the

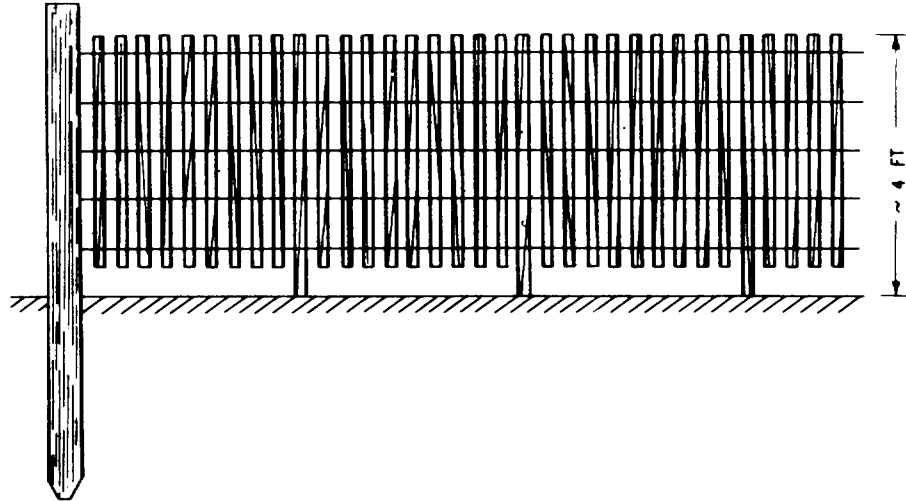


Figure 9-10. Vertical slat fence.

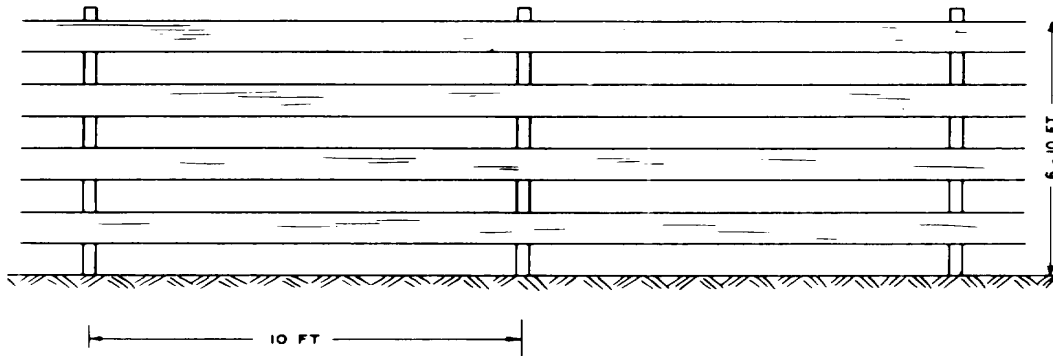


Figure 9-11. Fence made by stapling strips of reinforced paper or plastic strips onto wooden posts.

start of snowfall to provide continuous bare pavement.

(2) Principles of snow removal on airfield areas. The techniques described in this publication are provided only as a guide to be adhered to whenever and wherever possible. However, the following rules are considered vital and must be adhered to:

(a) Start snow removal operations on priority I areas, beginning with the primary instrument runway, immediately when snow begins to accumulate.

(b) During the initial phases, the major effort will be expended on the priority I areas.

(c) The severity of a snowstorm will determine the amount of area to be cleared. The initial plan must provide for clearance of the entire priority I area. Should snowfall increase, prevent clearance of the entire area, reduce operations and concentrate efforts on keeping the center of the primary instrument runway and taxiways open to aircraft movements. If this width will not accommodate operational needs, the operations must be



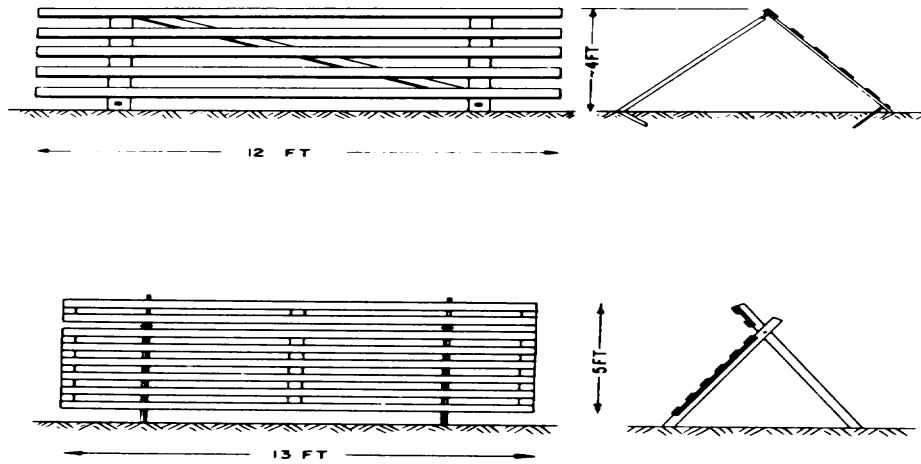


Figure 9-12. Inclined slat fences.

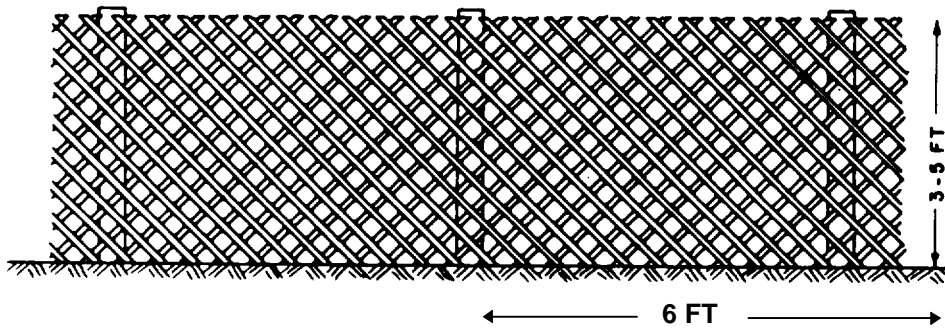


Figure 9-13. Trellis fence.

reduced and efforts concentrated to satisfy requirements.

(3) *Scope of operations.* Airfield snow removal operations will normally include using runway sweepers throughout the duration of the snowfall to maintain the center of the runway in bare pavement condition, regardless of the rate of snowfall. In light-to-moderate snowfall conditions, the scope of the operation should be enlarged to include the entire primary instrument runway, using displacement plows and rotary blowers, as needed, to remove the windrows accumulated by the sweepers. Under heavy snowfall conditions, the scope of the operations may be decreased to concentrate all ef-

forts on keeping the center-line portion open. Wind speed and direction determine the actual clearing pattern to be followed in many instances. It is necessary to maintain a safe distance between vehicles operating within a snow removal pattern so as to avoid accidents resulting from loss of visibility. Equipment movements must be carefully timed and coordinated to ensure an orderly turnaround and a safe reentry at the start of the return trip. Close liaison between the control tower, snow control, and the snow operations supervision must be maintained. The snow control radio net must be monitored at all times in the control tower when equipment is operating on the airfield. Snow removal

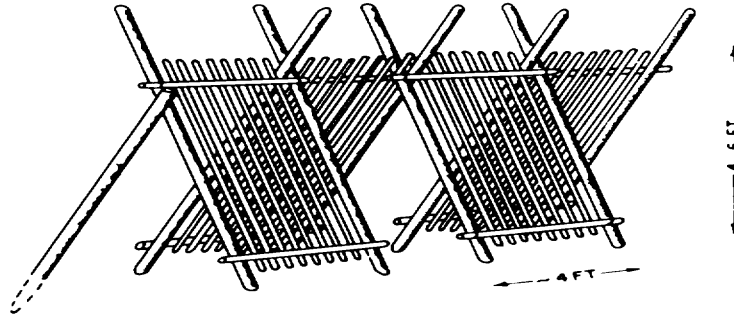


Figure 9-14. Old style russian snow fence.

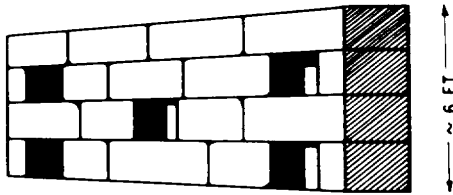


Figure 9-15. Snow block fence.

operations will take priority over other users on a multiple-user net.

(4) *Operations under variable wind conditions.* Still, parallel, nearly parallel, and light wind conditions.

(a) *Light snowfall.* Under parallel or no wind conditions, snow removal will start at one end of the runway on one side of the center line. When the windrow of snow resulting from the sweeping operations becomes sufficient, a displacement snowplow may be used for disposal. By clearing the center first, the runway is kept in operational readiness and available for aircraft movements.

(b) *Heavy snowfall.* The procedures and techniques remain basically the same as for a light snowfall, except when the rate of snowfall prevents the available equipment from maintaining full width, bare pavement conditions. One should reduce the scope of operations and concentrate the main effort on the center of the main runway until the snowfall lessens. During a heavy snowfall, the displacement snowplows will make several passes in each direction, accumulating a windrow for the high speed rotary plow to cast over the runway lights.

(5) *Cross-wind conditions.* High velocity, perpendicular, and strong cross-wind conditions.

(a) *Light snowfall.* It is permissible to commence snow clearing on the windward side of the runway and move the snow across the runway with the wind, providing time and aircraft operations permit. Once such a clearing pattern is started, it must be completed for the entire width of the runway; otherwise, the runway center line becomes obscured or a windrow is left on the runway. Except in the lightest of snowfall and wind conditions, snow removal during a crosswind will be carried out as described for heavy snowfall.

(b) *Heavy snowfall.* When a heavy snowfall is accompanied with a strong crosswind, snow removal operations must be concentrated on the runway center-line area. It is recommended that one sweeper in this particular pattern straddle or cover the center line at all times. A high speed displacement plow will be used to remove the windrow formed by the sweepers. Extreme care must be exercised in the end zone of turnaround area when this pattern is in use. The high speed rotary blower, if available, will be used to blow the snow completely off the runway area and over the lights whenever sufficient snow for this operation has been accumulated or windrowed by the high speed displacement plows.

(6) *Clearing runway edge lights.* Lights are an integral part of a runway system and must be maintained in a cleared condition in order to provide runway clearance for aircraft movements. Runway lights may be cleared during snow removal operations by using the air blast from the runway sweepers.

(a) During severe snow conditions, when snow removal operations are concentrated on run-

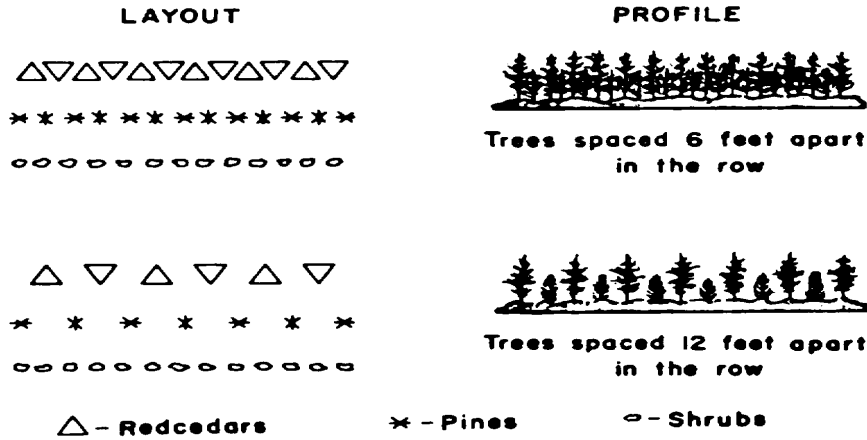


Figure 9-16. Shelterbelt or living snow fence.

way center-line clearing only, one sweeper may be needed to make continual passes to clear the lights. Runway edge lights are generally positioned several inches above the runway surface so that, even under heavy snowfall conditions, it would take considerable time for them to become buried.

(b) During light snowfall operations, a runway sweeper with the airblast chute positioned and adjusted for this purpose will be needed to make the last pass along the rows of runway lights, removing the snow from each light fixture with the air blast.

(c) Under heavy snowfall conditions, it may be necessary to use a displacement plow periodically to clear a path in front of the lights so that the sweeper air blast can be used to clear each one.

(7) *Removing snow and slush from inpavement (semi-flush) lights.* The raise (1/2 inch) runway center line, exit taxiway turnoff, and touchdown zone light fixtures will present a problem when packed snow, slush, or ice forms on the pavement. Caution should be used when operating a snowplow over the area. If equipped with a steel blade, it must be adjusted to clear the top of the lights. The sweeper or a blade with rubber cutting edge should be used whenever possible.

(8) *Clearing snow from arresting systems.* Certain small types of snowblowing equipment may be used around barrier installations. Manual labor may be needed to clear snow from the immediate vicinity of the barrier fixtures. This is normally accomplished by barrier maintenance personnel.

(a) *Overrun barriers.* Overrun arresting barriers are located at the end of the active runway and the beginning of the overrun area. Extreme care must be exercised in clearing snow in the vicinity of this system. Adequate snow removal from the over

run area must be accomplished to allow at least 850 feet of runout for this arresting system. It may be necessary to remove the net and cable from the runway during snow removal operation. If this is done, arresting system maintenance personnel must be available for removing and replacing the net and cable at the time of snow removal.

(b) *Runway barriers.* Barriers located on the runway should be deactivated and the pendant removed before snow removal operations. Snow will be removed to the distance required for effective use of the barrier.

e. *Encampment snow removal.* Unpaved roads are not plowed to the road surface; therefore, blade plow shoes must be installed and adjusted to keep the blade about an inch above the surface. Plowing speed may be too low to cast the snow well off the road but may tend to leave windrows along the edge. These can cause drifting under blowing snow conditions. Windrows should therefore be eliminated by blading, and a gentle slope (1: 4 is desirable) should be cut along the shoulders. Traction and directional control can be improved on the compacted surface of snow roads by cutting longitudinal grooves with a serrated blade mounted on a grader or under a truck (front-mounting may not achieve sufficient down-pressure to cut grooves). Fresh light snowfall can be rolled to build up the snow base rather than bladed off, and irregularities can be removed with a drag, followed by rolling.

f. *Other airfield areas.* Snow removal from around the following is done by the facility occupant by hand shoveling, small rotary blowers, and small tractor-mounted plows:

- (1) Aircraft hangars and shelters.
- (2) Grounding points.

(3) Parked aircraft.

*g. Snow disposal.* Where there is inadequate storage space for plowed snow, such as in warehouse or other built-up areas, it will be necessary to load and haul snow to a disposal area. Hauling of snow removed from sidewalks near buildings may also be necessary. Either front-end loaders or rotary plows are used for loading. Rotary units are faster and also safer in traffic areas because they eliminate the backing operation required of a front-end loader.

Conveyer units are also used, but they are slower and less maneuverable than rotary plows.

*h. Snow control with thermal systems.* Applying thermal energy to the pavement by means of embedded heating systems is one of the most effective methods of melting ice and preventing the formation of compacted snow. This is accomplished by installing pipes carrying hot liquid, or cables for electrical resistance heating. However, high cost of capital construction and operation limits application to major problem areas. A heat input of 10 to 20 watts per square foot is required under most conditions to maintain the pavement surface temperature above freezing. High temperatures of the heated elements must be avoided to prevent thermal stress cracking. Application of heat from above the pavement by means of jet engines, weed burners, and pavement planers has been attempted repeatedly with little success. Melting rates are extremely slow, fuel consumption is high, refreezing of poorly drained melt is common, and damage to pavements and joints has been experienced.

## 9-5. Ice control and removal

Removal of ice from a pavement after it has formed (deicing) requires the expenditure of greater effort and time than does the prevention of ice formation (anti-icing). Two methods of anti-icing are currently utilized: the application of a water-soluble chemical onto the pavement either in liquid or solid form before or during the early stages of an icing occurrence, and the installation of heated sources into pavements to prevent freezing.

*a. Chemical deicing.* The principal justification for applying deicing chemicals to keep a pavement bare at all times is to prevent the buildup of snowpack. This procedure requires the chemical to be spread on the runway just before or at the start of the freezing condition. This requires accurate information on pavement surface temperature and air temperature along with forecast data. Salt distributed on the pavement during falling snow conditions keeps the snow mealy and prevents the buildup of the compacted snow mass which will adhere tightly to the pavement. In those cases where maintenance crews have not applied suffi-

cient salt in time, a compacted snow mass can build up which may take days to remove by laborious, costly time-consuming, and marginally effective methods. Anti-icing chemicals are most effective at near freezing temperatures. Their effectiveness depends upon the proportion of chemical to water in solution. It is necessary to monitor carefully the surface after the chemical treatment. At the first sign of slushing, the treated area should be swept.

The need for additional chemical will seldom be necessary, except in the case of prolonged freezing precipitation or rapidly dropping temperatures. It is imperative that proper anti-icing techniques be understood and adhered to as chemicals are expensive and only effective under certain conditions. Antiicing or the prevention of the forming of relatively thick (V2 inch) ice or compacted snow on a runway is fairly simple as compared with the cost and effort required to remove it once it has formed. For these reasons, anti-icing procedures should always be used on main runways and taxiways and, when needed, on lower priority airfield areas. In the event that freezing rain turns to snow, the treated area must be swept, followed as required by proper snow removal procedures.

(1) *Common deicing chemicals.* Common deicing chemicals can be divided into three classes: . The first class is solid chemicals and include sodium chloride, NaCl; calcium chloride, CaCl<sub>2</sub>; and urea, CO(NH<sub>2</sub>)<sub>2</sub>. The second class is aqueous solutions of crystalline chemicals which include all the solid chemicals dissolved in water. The last class is liquid chemicals, which include ethylene glycol, propylene glycol, and alcohol (ethyl, methyl, propyl, isopropyl).

(2) *Stockpiling of chemicals.* Since deicing chemicals are readily soluble in water, it is clearly desirable to prevent their exposure to water before spreading. Though a crust will form on the surface of sodium chloride and calcium chloride stockpiles, some leaching will take place subsequently during rainfall or when accumulated snow melts. For the most positive protection, chemicals should be stored inside a covered, leakproof shelter. When not stored within a building, the chemicals should be placed on a paved surface and covered with a tarpaulin. Since it is difficult to prevent all leaks by this method, and impossible to keep out all sources of water if loading operations take place during storms, the impervious pad should be pitched to or surrounded by drainage channels which can carry the dissolved salt to a collection basin or a diversion channel. Straight salt should be covered at all times during the winter, but low precipitation and low temperatures during the winter usually make it unnecessary to cover treated sand piles except in special problem areas. When rain does fall on an uncovered

salt pile, it can generate about 625 gallons of brine per inch of rainfall per 1,000 square feet of stockpile. The brine flowing from the base is nearly a saturated solution. On large stockpiles the loss per year can reach about one-eighth of the initial weight of the pile for each inch of rainfall. Salt kept inside buildings is easier to work with than salt stored under plastic covers. It is particularly difficult to cover, uncover, and prevent damage to the plastic cover on stockpiles over 75 tons. Treated sand should be mixed as late as possible to avoid late fall rains which will leach out the salt and upset chemical distribution within the pile. Sand/chemical ratio should be minimized in treated sand piles. The recommended mixture is 80 to 100 pounds of sodium chloride per cubic yard of sand. This amount will freeze-proof the stockpile and should be done early enough in the season to allow the salt to dissolve in the sand. Pile shape should approach a windrow with conical ends for best results. Those measures which can be taken with present facilities should be identified to minimize the effects of stockpile runoff such as diluting salt brine runoff, controlling direction of runoff flow, settling out sand carried in suspension which can smother vegetation, and removing dead vegetation.

*b. Ice control with thermal systems.* The use of thermal or heat sources to prevent formation of ice can be very effective but in most instances unaffordable as discussed earlier.

*c. Chemical removal techniques.* Chemicals may be applied to pavements for ice removal. The common chemicals used, sodium chloride (salt) and calcium chloride are extremely corrosive to unprotected metals and must not be used where aircraft will be exposed to the chemical. Noncorrosive chemicals for use on airfield pavement include urea, ethylene, or propylene glycol (or aircraft deicing fluids which are principally glycols), and alcohols. These chemicals are all very expensive, and primary reliance on ice control and removal should be placed on prevention of ice formation. The optimum application rate is based on the level of service required, weather conditions and their change with time, the state and characteristics of the chemicals used, the time of application, the traffic density at time of chemical application, and subsequently, the topography and type of road surface. Determination of the proper application rate is a matter of judgment and a guess about what the weather conditions will be following the application. If a treatment is made based upon the expectation that a storm will continue for several hours, and it does not, the amount applied will have been excessive. It is best to apply a minimum treatment, then apply a second treatment if observation indicates the neces-

sity. Quantities recommended for various weather, snow, and road conditions are given in table 9-1.

(1) *Addition of liquid chemical.* Liquid calcium chloride can provide the needed moisture for initiating the melting action of sodium chloride (rock salt). Field tests have produced the following results: quicker snow melting since the 30 to 45 minute time usually required for brine to form is nearly eliminated, less salt waste as wetted salt does not bounce on ice or snow but adheres and begins to bore through the frozen layer immediately, greater latitude in use of rock salt melting has been experienced with prewetted salt at temperatures as low as 3 degrees F (normal salting is terminated when temperatures drop below 20 degrees F), eventual reduction in amount of salt applied due to the quicker, more effective use of the material, and greater periods of bare pavement surfaces during winter snow and ice storms.

(2) *Road application.* Concentrated spreading of salt, either in a narrow band on two-lane roads or in a 4-foot wide band spread near the centerline crown or on the high side of superelevations, is the most efficient use of chemicals. Here, the purpose is to obtain a concentrated brine in contact with the pavement which will flow under the snow or ice to break the bond and enable traffic and plowing to remove the accumulation. Early exposure to the sun of a portion of the road surface which may be achieved by concentrated spreading will also increase the melting rate by absorption of heat energy. However, unpaved road surfaces will not absorb much solar radiation and therefore melting will be slower. The common gradation of salt requires 8 gallons of liquid per ton of salt to wet the surface of each particle based on an average application rate of 300 pounds per mile distributed at 20 miles per hour. The liquid used is a 32 percent solution of calcium chloride (3.75 pounds of 94 to 97 percent CaCL<sub>2</sub> per gallon of solution) which has a eutectic temperature of about -17 degrees F.

(3) *Airfield application.* Neither sodium nor calcium chlorides are permitted to be used on airfields because of their corrosion of aircraft metals. Several approved ice control chemicals may be used under different weather conditions to prevent or eliminate ice from airfield pavements.

(a) *Urea.* Shotted or prilled urea can provide effective ice control if the temperature is not too low. Of the available chemicals, Urea (Aero)\* is the suggested chemical for airport use when the pavement

---

\*Urea (Aero) prills are urea especially formulated for use on airfield pavements and will have a greater concentration of soluble urea than the prilled urea used for agriculture fertilizer, but both are acceptable for use on airfield pavements for ice control.

Table 9-1. Chemical application rates for roads.

Temperature Range	Precipitation Type	Treatment	Rate (lb/mile for Two-Lane Road)	Remarks
Near freezing (30 to 35° F)	Freezing rain	NaCl	200	
	Wet snow	NaCl	500	
20 to 30° F	Freezing rain	NaCl	200-400	
		Snow	NaCl	300-500
	Snow	5:1 NaCl-CaCl <sub>2</sub>	200-300	
		5:1 NaCl-CaCl <sub>2</sub>	250-400	
Below 20° F	Snow	None if pavement and snow are dry		
		3:1 NaCl-CaCl <sub>2</sub> for removal of compacted snow or Abrasive for traction improvement	500-600  1,200-1,500	For heavily traveled roads  For low traffic density roads, or at critical points (e.g., hills, intersections)

**Notes: NaCl-CaCl<sub>2</sub> mix ratios are based on volume measure; CaCl<sub>2</sub> is 77 to 80% flake (type 1). When temperature at time of application is falling, use next lower temperature treatment.**

surface temperature is above 15 degrees F; urea should never be used below that temperature. The spreading device should be a suitable self-contained granular material-spreading unit having a positive feed mechanism, a spread control device, a 5 to 7 cubic yards capacity, and be suitable for mounting on a snowplow truck. The rate of application suggested for Urea (Aero) prills ranges from 0.32 to 2.17 pounds per square yard, contingent upon the surface temperature and the thickness of the ice (see table 9-2). It is suggested that a test area be used to determine the exact rate of application needed to produce the desired results. Urea is not

effective on ice in excess of 1/4 inch thickness and is most effective on very thin ice. Consequently, ice should be scraped down as thin as possible before resorting to chemicals. Urea for deicing should be applied at the rate of 1 pounds per 100 square feet of pavement surface. As the temperature drops below the mid-twenties, this rate may have to be increased slightly. After urea has been applied, snow removal equipment should remain off the treated area until the chemical has had time to melt or loosen ice. This will vary from about 15 minutes (if the temperature is only several degrees below freezing or the sun is shining) to about 30 minutes under

Table 9-2. Ice-dissolving capacity of urea, pounds per square yard

Ice Thickness, inch	Temperature			
	15° F	20° F	25° F	30° F
1/16	1.09	0.79	0.50	0.16
1/8	2.17	1.59	1.01	0.32
3/16	3.26	2.38	1.51	0.48
1/4	4.35	4.17	2.01	0.64
5/16	5.44	4.96	2.52	0.80
3/8	6.53	5.75	3.02	0.96
7/16	7.62	6.54	3.53	1.12
1/2	8.71	7.33	4.03	1.28

**Caution:** Whenever urea or other chemicals are used to remove ice, the previous comments on slush and water should be kept in mind. Liquid melt, on top of the ice causes the surface to become very slippery. Aircraft movement surfaces should be reopened to air craft only after a thorough inspection indicates the ice has been completely removed.

more severe conditions. When the ice has melted or has loosened, airblast sweepers should be used to remove slush and water. When the windrow of slush becomes too heavy for the sweepers to handle effectively or has been worked out beyond the limits of the treated area, underbody scraper blades, fol-

lowed by the sweepers, should be used to scrape off the remaining ice.

(b) *Isopropyl alcohol.* Grade B isopropyl alcohol is authorized for use as an anti-icing and deicing agent. The proper alcohol mixture is shown in table 9-3. Isopropyl alcohol is effective as an anti-icing

Table 9-3. Freezing point of isopropyl alcohol water mixtures

Percent of Alcohol by Volume	°F
5	29
10	26
15	21
20	17
25	12
30	6
40	- 1
45	- 2
50	- 5
55	- 7
60	-10
65	-12
70	-16
75	-26
80	-43

and deicing agent at temperatures as low as - 12 to - 15 degrees F. It is used undiluted at these temperatures. The isopropyl alcohol mixture should be applied at the rate of 10 gallons per 1,000 square feet or according to the manufacturer's instructions. On layers of ice 1/16 inch or more, application without dilution is advisable. After the ice has been softened or melted by the alcohol, it may be further loosened with the underbody blade and then removed with the airblast sweeper. The sweeper will sweep the liquid and slush off the side and gradually widen the cleared area. A repeat operation may be required in the event of heavy slush. Dilution of the alcohol-water mixture as the melting proceeds may result in a freezable solution.

(c) *Ethylene glycol.* Ethylene glycol is used as both an anti-icing and deicing agent and normally

applied in undiluted form applied at a rate of 4 gallons per 1,000 square feet of surface covered with ¼4-inch ice or according to the manufacturer's instructions.

(4) *Environmental effects of deicing chemicals.* All deicing chemicals are pollutants when present in large concentrations in the environment. Sodium chloride is the largest contributor to pollution because it is used in the greatest quantity. Effects on vegetation are generally confined to within a few feet of the pavement, though splashing and salt spray may affect trees some distance away. Calcium chloride is much less of a pollutant than sodium chloride because of the lesser quantities used and because the calcium ion is less mobile and therefore less assimilated by vegetation. Sodium chloride level must not exceed 250 parts per million in



potable water. The organic deicing chemicals, urea, glycols, and formamide do not seriously affect vegetation. Urea, which is a fertilizer, will stimulate vegetation growth and therefore may increase the need for mowing or vegetation control in affected areas. All the chemicals are toxic to aquatic life at high concentrations: above 10,000 milligrams per liter for urea, above 5,000 milligrams per liter for the glycols, and above 5,000 milligrams per liter for formamide. However, these levels are seldom likely to be reached.

(a) *Pavement deterioration from deicing chemicals.* PCC pavements may be deteriorated by applying deicing chemicals and subsequent freeze-thaw cycling. The cause is primarily physical in nature, and therefore, the common deicing chemicals (sodium chloride, calcium chloride, urea, ethylene glycol) will also affect the surface to some extent, though calcium chloride will have the least effect because of the low freezing point and therefore the lesser number of freeze-thaw cycles that will normally be encountered. Ammonium salts (ammonium sulfate and ammonium nitrate) react chemically with concrete and cause the serious degradation; they will be avoided. Concrete should contain 5 to 7 percent entrained air for maximum resistance to freeze-thaw. Use of penetrating sealers can reduce the surface degradation, particularly of new concrete.

(b) *Pavement sealers.* Tests have shown that the most effective sealant is a 1: 1 volume mixture of boiled linseed oil in kerosene. This should be applied in two coats: the first at a rate of 400 square feet per gallon, the second at 600 square feet per gallon. The sealant should not be applied to wet concrete; wet concrete should be allowed to dry for 1 or 2 days at temperatures of 60 to 90 degrees F and relative humidities of 20 to 60 percent before application. The second coat can be applied after the first has dried (several hours at 70 to 80 degrees F); if the concrete was extremely dry, either it will be wetted and allowed to dry for 1 or 2 days or a third linseed oil treatment will be applied. Retreatment will be made annually for the first 3 years of the life of new concrete. After 3 years, little benefit results from sealant applications. Old concrete that has already begun to scale can also be sealed with linseed oil; however, durability is not improved as much as with new concrete. Skid resistance of pavements treated with linseed oil is initially reduced slightly, but to a lesser degree than any other surface treatment that has been investigated. Wet skid resistance values reach the before-treatment values within 24 hours. Bituminous and tar-rubber pavements are not significantly affected by deicing chemicals; only minor degradation of isolated ex-

posed aggregate particles has been observed.

d. *Mechanical ice removal methods.* Ice is soft and not tightly bonded to pavement near the freezing point, 32 degrees F. As the ice temperature drops, however, both hardness and strength of the adhesive bond increase, and removal difficulty is increased. Front-mounted plow blades are satisfactory for removing ice near the freezing point if the cutting edge is allowed to ride on the pavement. At plowing speeds above about 10 miles per hour, the plow tends to bounce and leave ice on portions of the road; operators should be aware of the characteristics of their equipment in this respect (heavier plows and slower speeds reduce this "proposing" or bouncing). Carbon steel cutting edges run in contact with the pavement wear rapidly; blade changes are frequently necessary during a single shift. Tungsten carbide cutting edges are extremely tough and can last for thousands of miles; however, their brittleness will result in blade chipping when run over pavements with metal projections such as manhole covers or steel rails. Slush and soft ice are removed effectively by rubber blades which squeegee the pavement. Serrated blades which cut grooves in the surface are sometimes used and will facilitate retention of chemicals or abrasives on the traveled way when they might otherwise be blown off. Grooving an ice surface also improves vehicle steering control. Ice is more effectively removed by blades to which a downward force is applied. Though down pressure can be applied by double-acting hydraulic cylinders or separate downloading cylinders on front-mounted plows, underbody blades can apply greater pressure without reducing steering control. Underbody blades must have a trip mechanism to release the blade upon striking an obstacle in order to reduce damage to the blade, truck, pavement insert, and pavement. The moldboard on a grader is similar in function to a truck-mounted underbody blade, even though a grader is sometimes a handicap. Various means have been employed to apply high mechanical loads to the ice surface in an attempt to break it from the pavement. Wobble-wheel rollers, chains, chain flails, and other impact devices have been used, but pavement damage is generally severe, and removal efficacy is marginal, so these methods should be avoided. Abrasives do nothing to prevent the buildup of "pack" but will increase the skid resistance of the surface which can soon be covered by additional snowfall or scattered by traffic action. However, abrasives can be used in such locations as low speed highways and on hills and curves and points of deceleration, that is, locations where fast traffic and aerodynamic forces will not blow the abrasive off the surface promptly. Sand does not remove ice but may insulate it.

In emergency conditions such as the absence of deicing chemicals and the necessary mechanical equipment, icy runway surfaces may be kept in operational condition by using sand. Sand and washed stone used on airfield surfaces should be clean, free running, free from loam or clay with 100 percent

passing a No. 4 sieve and not more than 30 percent passing a No. 5 sieve. Dry, clean storage facilities are essential to avoid contamination with road sand which may be treated with calcium or sodium chloride (because of the corrosive effects of chlorides on certain aircraft materials).

## CHAPTER 10 PREVENTATIVE MAINTENANCE

---

### 10-1. Rationale for maintenance

Preventative maintenance of roads, streets, hardstands, and runways should provide a means to detect early any apparent deterioration of the structure. Early detection and maintenance may not entirely eliminate the requirements of eventual replacement of the surfaced area, but will be a major factor in lengthening its life and reducing maintenance and repair problems and costs. Adequate preventative maintenance results in more efficient, economical operations. In order for such a program to be successful, a knowledge of what causes early deterioration is required. It is the responsibility of the surfaced area maintenance supervisor to assign qualified personnel to perform the necessary inspections. The maintenance crewmen are responsible for correcting minor defects and reporting them to their supervisor.

### 10-2. Inspection and records

The roads, streets, hardstands, and runways that an installation has to manage should be divided according to makeup, location, and frequency to use. These areas are normally coded in such a manner as to make them readily identifiable. A pavement management system will provide a method of procedure for inspection of pavement condition, cause and repair method, economic analysis, and data management. The system as a minimum should relate a description of the area, date of inspection, recommended maintenance, and work accomplished. These cards may be color coded, flagging the card for frequency of inspections. By having a precise history of the surfaced area, planning maintenance and assigning of funds may be accomplished more economically. Any unusual or major incidents which would affect maintenance or usage of facilities should be noted.

*a. Unpaved roads.* Unpaved roadway surfaces should be maintained in a smooth well-drained condition to prevent rutting, potholes, and similar irregularities. Inspection of unsurfaced roads will be made at frequent intervals, and additional inspections will be made after heavy storms with special emphasis on drainage problems. Extremely dry weather will also require additional care to prevent surface degradation. Unsurfaced areas should be repaired immediately to avoid extreme damage in wet or dry conditions.

*b. Paved areas.* Guidance concerning pavement maintenance management and pavement condition surveys for paved surface can be found in TM

5-623. Information concerning pavement condition surveys for airfields can be found in TM 5-826-6/ AFR 93-5.

(1) Concrete pavements are examined for cracks induced by loading, expansion, or other causes. These cracks need to be sealed with joint sealer that meets applicable specifications. If new cracking is discovered, frequent observations to determine the cause should be made so that corrective measures may be taken before spalling or other problems become widespread. A check for pumping and settlement should also be made. All drainage features should be observed so that early corrective maintenance can be performed. Examination of area should also note any scaling, spalling, disintegration, or other types of failures. Spalling normally occurs at joints, corner breaks, or any area where cracks have appeared. Causes should be determined and steps taken to remove and replace deficient areas. Supporting foundations and structures appurtenant to concrete pavements should also be inspected. Early observation of signs of distress will permit immediate correction before serious failure occurs.

(2) Flexible or asphalt pavement surfaces require about the same inspection and action as do rigid or concrete surfaces. Cracks should be noted, their cause determined, and then sealed by proper method and material. Weathering is caused by oxidation from the effects of air, water, and sun. This condition is normally determined during very dry weather and is usually indicated by loss of color, fine surface cracking, and brittleness. Raveling should be controlled immediately to eliminate loose material detrimental to the use of the area. Bleeding is usually caused by too much bitumen and normally occurs in hot weather. These areas should be sprinkled with sand to eliminate the slick hazardous surfaces. Potholes need immediate attention to prevent serious traffic hazards and possible damage to the base and subgrade. Settlement and depressions may be caused by inadequate or defective drainage. Careful inspection will determine the cause so that proper maintenance can be performed.

*c. Shoulders and roadsides.* These areas also require inspection because proper functioning of them has a direct bearing on drainage and stability of the adjacent pavement. Severe failures such as slides may be prevented by early detection and minimum maintenance.

*d. Drainage system.* The inspection should include looking for debris, cave-ins, and other stoppages. The systems should be checked for peak load

requirements during storms and any inadequacies should be noted. Culverts, inlet headwalls, and exits need to be checked for possible erosion, settlement, and wash. Minor changes and additions may prevent serious and expensive maintenance or repairs.

e. *Bridges.* Signs of deterioration such as rust in metal structures, damage and decay in wood, and cracking, spalling, and chemical damage in concrete should be checked. Minor repairs and maintenance will prolong usable life of structures before major repairs become necessary. Personnel required to make inspections of bridges should have some experience relating to construction and maintenance of bridges.

### 10-3. Maintenance strategies and performance of paved roads

The methods, materials, and procedures given are those which can be used on pavements to extend the life of the pavements. These may be applied even though the pavement surface shows no distress.

These practices will extend the useful life of the pavement.

a. *Rejuvenators.* Rejuvenators (see chap 3) are

products that can be applied to asphalt pavements to modify the asphalt properties to approximately those of a new asphalt.

b. *Fog seal.* A fog seal (see chap 3) is a spray application using an emulsified asphalt. It is a light coating sprayed on various asphalt surfaces to seal voids in the pavement surface or bind loose aggregate to the surface.

c. *Slurry seals and bituminous surface treatments.* Slurry seals and bituminous surface treatments (see chap 3) can provide effective wearing surfaces for asphalt pavements exhibiting surface distress.

d. *Joint and crack sealing.* See chapters 3 and 4 for details on joint and crack sealing for asphalt and concrete pavements. By keeping all joints and cracks sealed, the amount of water penetrating into and under the pavement is minimized.

e. *Undersealing.* Undersealing (see chap 4) is used to fill voids to help stabilize slabs which have been undermined usually by pumping or some water action. This will help prevent the slabs from cracking or breaking by filling voids and preventing water from getting into and weakening the subbase.

## APPENDIX A

### REFERENCES

---

#### Section I

#### Required Publications

*Departments of the Army, the Navy, and the Air Force*

#### **TM 5-623**

Pavement Maintenance Management (cited in para 3-3 and 4-3).

#### **TM 5-820-1**

Surface Drainage Facilities for Airfields and Heliports (cited in para 7-4).

#### **TM 5-820-2/AFM 88-5, chap 2**

Drainage and Erosion Control-Subsurface Drainage Facilities for Airfield Pavements (cited in para. 7-4).

#### **TM 5-820-3/AFM 88-5, chap 3**

Drainage and Erosion-Control Structures for Airfields and Heliports (cited in para 7-4).

#### **TM 5-820-4/AFM 88-5, chap 4**

Drainage for Areas Other Than Airfields (cited in para. 7-4).

#### **TM 5-822-14/AFJMAN 32-1019**

Soil Stabilization for Pavements (cited in para 5-2c(2)(a)).

#### **TM 5-822-8/AFM 88-6, chap 9**

Bituminous Pavements-Standard Practice (cited in para 3-2b, 3-2c, 3-3e(2), 3-5a, 3-5e, 3-5i, 3-7g(1), 3-7g(3), and 3-7i(1)).

#### **TM 5-822-9/AFM 88-6, chap 10**

Repair in Rigid Pavements using Epoxy Resin Grouts, Mortars and Concretes (cited in para 4-5d).

#### **TM 5-825-2/AFM 88-6, chap 2/NAVFAC DM-21.3**

Flexible Pavement Design for Airfields (cited in para 2-1a and 2-2e(2)).

#### **TM 5-826/AFR 93-5**

Procedures for U. S. Army and U. S. Air Force Airfield Pavement Condition Surveys (cited in para 3-3).

#### **TM 5-822-11/AFM 88-6, chap 7**

Standard Practice for Sealing Joints and Cracks in Rigid and Flexible Pavements (cited in para 3-7a, 4-7e(1), and 4-7e(2)).

#### **AFM 91-14**

Airfield and Base Snow and Ice Removal and Control (cited in para 1-2).

#### **AFM 91-23**

Operation and Maintenance Guide Specification (cited in para 4-7e(2) and 4-7g(1)).

#### **AFR 88-35**

Mobile Airfield Marking Team cited in para 4-7e(2).

#### **AFR 93-5**

Airfield Pavement Evaluation Program (cited in para 4-3).

#### **MO-102.5**

Pavement Maintenance Management (cited in para 3-3)

#### **NAVFAC DM-5**

Civil Engineering (cited in para 2-2e(2), 3-2c, 3-3e(2), 3-5a, 3-5e, 3-5i, 3-7g(1), 3-7g(3), 3-7i(1), 5-2c(2)(a), and 7-4a).

#### **NAVFAC**

Instruction Facilities Projects Manual (cited in 11010, 20E, para 1-2).

#### *Nongovernment Publications*

#### **American Society for Testing and Materials (ASTM) publications**

For publications, write ASTM, 1916 Race St., Philadelphia, PA 19103.

#### **C 881**

Epoxy-Resin-Base Bonding Systems for Concrete (cited in para 4-5d)

#### **D 490**

Tar (cited in para 5-2c(2)(f))

#### **D 558**

Moisture-Density Relations of Soil-Cement Mixtures (cited in para 5-2c(2)(c)).

#### **D 559**

Wetting and Drying Tests of Compacted Soil-Cement Mixtures (cited in para 5-2c(2)(c)).

#### **D 560**

Freezing and Thawing Tests of Compacted Soil-Cement Mixtures (cited in para 5-2c(2)(c)).

#### **D 24875**

Standard Classification of Soils for Engineering Purposes (cited in para 2-2b).

#### **D 3282**

Classification of Soils and Soil-Aggregate Mixtures for Highway Construction Purposes (cited in para 2-2a).

*U. S. Department of Transportation, Federal Highway Administration publications* For the following publications, write Federal Highway Administration, 400 7th St., Washington, DC 20590.

**Federal Highway Administration**

Manual of Uniform Traffic Control Devices for Streets and Highways (cited in para 6-6a(1)).

**Federal Specifications**

**SS-S-1401C**

Sealant, Joint, Non-Jet-Fuel-Resistant, Hot-Applied, for Portland Cement and Asphalt Concrete Pavements (cited in para 4-5c(3)(a)).

**SS-S-1614A**

Sealant, Joint, Jet-Fuel-Resistant, Hot-Applied, for Portland Cement and Tar Concrete Pavements (cited in para 4-5c(3)(b)).

**SS-S-200E**

Sealant, Joint, Two-Component, Jet-Blast-Resistant, Cold-Applied for Portland Cement Concrete Pavement (cited in para 4-5c(4)(b)).

**Section II**

**Related Publications**

A related publication is a source of additional information. The user of this publication does not have to read a "related publication" to understand this publication.

**AFR 75-88**

Highways for National Defense

**AFR 85-10**

Operations and Maintenance of Real Property

**AFR 91-24**

Sealing Joints in Airfield Pavements

**AFR 125-14**

Motor Vehicle Traffic Supervision

**AFR 127-12**

Air Force Occupational Safety and Health Program

**AFR 127-101**

Accident Prevention Handbook

*Departments of the Army, the Navy, and the Air Force*

**FM 5-446**

Military Non-Standard Fixed Bridging

**TM 5330/AFM 86-3, Vol 11, Change 1**

Planning and Design of Roads, Airbases, and Heliports in the Theater of Operations

**FM 5434, Sep 92**

Earthmoving Operations

**TM 5-331C**

Utilization of Engineer Construction Equipment: Vol C, Rock Crushers, Air Compressors, and Pneumatic Tools, Change 1

**TM 5-331D**

Utilization of Engineer Construction Equipment: Vol D-1 Asphalt and Concrete Equipment

**TM 5332**

Pits and Quarries

**TM 5-803-4**

Planning of Army Aviation Facilities

**TM 5-818-6/AFM 88-32**

Grouting Methods and Equipment

**TM 5-822-2/AFM 88-7, chap 5**

Geometric Design for Roads, Streets, Walks, and Open Storage Areas

**TM 5-822-7/AFM 88-6, chap 8**

Standard Practice for Concrete Pavements

**TM 822-10/AFM 88-6, chap 6**

Standard Practice for Pavement Recycling

**TM 5-823-4**

Marking of Army Airfield-Heliport Operational and Maintenance Facilities

**TM 5825-1/AFMAN 32-8008, Vol 1**

General Provisions for Airfield/Heliport Pavements Design

**TM 5-825-2-1/AFM 88-6, chap 2, sec A**

Flexible Pavement Design for Airfields, Elastic Layered Method

**TM 5-825-3/AFM 88-6, chap 3**

Rigid Pavements for Airfields

**TM 5-826-1/AFM 88-24, chap 1**

Airfield Pavement Evaluation Concepts

**TM 5-826-2/AFM 88-24, chap 2**

Airfield Flexible Pavement Evaluation

**TM 5-826-3/AFM 88-24, chap 3**

Airfield Rigid Pavement Evaluation

**TM 5-826-4**

Engineering and Design: Army Airfield-Heliport Pavement Reports

**TM 5-803-13/AFM 126-8**

Landscape Design and Planting Criteria

**TM 5-8303/AFM 88-17, chap 3**

Dust Control for Roads, Airfields, and Adjacent Areas

**AFM 85-9**

Inactive Installations-Inactivation and Maintenance

**AFM 171-200**

The Base Engineer Automated Management System (BEAMS)

**AFM 86-1**

Programming Civil Engineer Resources

**AFM 8814**

Visual Air Navigation Facilities

**AFM 8819**

Arctic and Subarctic Construction

**AFM 125-7**

Motor Vehicle Traffic Supervision

**NAVFAC DM-2**

Structural Engineering

**NAVFAC DM-6**

Guide Specification Manual

**NAVFAC DM-7**

Soil Mechanics, Foundations, and Earth Structures

**NAVFAC DM-21**

Airfield Pavements

**NAVFAC DM37.3**

Outdoor Sports and Recreational Facilities

**TDS 72-06**

Snow Compaction Equipment-Snow Rollers

**TDS 73-01**

Snow Drift Control for Runways and Skiways

**TDS 73-18**

Use and Additives to Increase Life of Asphalt Slurry Seals

**TDS 74-02**

Rapid Hardening Concrete for Repairing Concrete Structures at Any Geographic Region

**TDS 74-065**

Snow Compaction Equipment-Leveling and Grading

**TDS 74-06**

Snow Compaction Equipment-Drags

**TDS 75-19**

Removing Rubber from Airport Runways

**TDS 75-22**

Floor Maintenance Problems

**TDS 75-33**

Airfield Marking Paints

**TDS 76-07**

Airfield Pavement Roughness

**TDS 76-09**

Reflective Floor Finishes for Aircraft Maintenance Hangars

**MO-102.5**

Pavement Maintenance Management

**NAVFAC Instruction 11012A**

Liquid Oxygen Compatible Joint Sealants for Pavements and Floor Slabs

**NAVFAC Instruction 1132.13B**

Navy Utilization of Air Force Services and Equipment for Stripping Airfield Pavements

**NAVFAC P-455, Book 2**

Construction Engineering Handbook-Site Work

**NAVFAC P-457**

Planning and Design of Outdoor Sports Facilities

## GLOSSARY

### Section I

#### Abbreviations

##### AC

Asphalt concrete

##### OSHA

Occupational Safety and Health Administration

##### PCC

Portland cement concrete

##### PFC

Porous friction course

##### PFS

Porous friction surface

##### USCS

Unified Soil Classification System

### Section II

#### Terms

##### Admixture

A material other than water, aggregates, hydraulic cement, and fiber reinforcement used as an ingredient of concrete or mortar and added to the batch immediately before or during its mixing.

##### Aggregate

A granular material of mineral composition such as sand, gravel, shell, slag, or crushed stone, used with a cementing medium to form mortars or concrete, or alone as in base courses, railroad ballasts, etc.

##### Base course

A layer of specified selected material of planned thickness constructed on the subgrade or subbase of a pavement to serve one or more functions such as distributing loads, providing drainage, or minimizing frost action.

##### Blow-up

Blow-ups or buckles occur in hot weather, usually at a transverse crack or joint that is not wide enough to permit slab expansion. The insufficient width is usually caused by infiltration of incompressible materials into the joint space. When expansion cannot re-

lieve enough pressure, a localized upward movement of the slab edges (buckling) or shattering will occur in the vicinity of the joint. Blow-ups can also occur at utility cuts and drainage inlets.

##### Cold milling

Cold milling is the removal of asphalt concrete by a piece of equipment with a rotating drum containing teeth to mill (grind, pulverize) or remove the pavement in place and without heating.

##### Cold mix

Cold mix is a patch material made through a combination of cut-back asphalt binder and aggregates.

##### Cold recycling

Cold recycling is the reuse of old asphalt concrete pavement to make new asphalt concrete pavement without the use of additional heating.

##### Concrete patches

Patches in PCC pavements made with additional PCC materials.

##### Corner break

A corner break is a crack that intersects the joints at a distance less than or equal to one-half the slab length on both sides, measured from the corner of the slab. For example, a slab with dimensions of 12 by 20 ft (3.7 by 6.1 m) that has a crack 5 ft (1.5 m) on one side and 12 ft (3.7 m) on the other side is not considered a corner break; it is a diagonal crack.

However, a crack that intersects 4 ft (1.2 m) on one side and 8 ft (2.4 m) on the other is considered a corner break. A corner break differs from a corner spall in that the crack extends vertically through the entire slab thickness, while a corner spall intersects the joint at an angle. Load repetition combined with loss of support and curling stresses usually causes corner breaks.

##### Cracking

A complete or incomplete separation, of either concrete or masonry, into two or more parts produced by breaking or fracturing.

##### Crazing

The development of fine random cracks or fissures on the surface; the pattern of craze cracks existing in a surface.

##### Divided slab

The slab is divided by cracks into four or more pieces due to overloading and/or inadequate support. If all pieces or cracks are contained within a corner break, the distress is categorized as a severe corner break.

##### Faulting

Differential vertical displacement of a slab or other member adjacent to a joint or crack.

##### Flexible pavement

Pavement that provides a waterproof surface while using the strength of the underlying pavement structure (base and subbase course and subgrade) to support the load.

##### Fly ash

The finely divided residue resulting from the combustion of ground or powdered coal and which is transported from the firebox through the boiler by flue gases.

##### Fog seal

A fog seal is a relatively light application of bituminous material to the surface of an asphalt concrete pavement.

##### Full-depth patch

A full-depth patch is a patch that extends the full depth of the slab being repaired.

##### Grooving

Grooving is the placement of a series of grooves or saw cuts (usually V4-in. deep and V4-in. wide) in a pavement surface to improve skid resistance.



**Grout**

A mixture of cementitious material and water, with or without aggregate, proportioned to produce a pourable consistency without segregation of the constituents; also a mixture of other composition but of similar consistency.

**Hot mix**

Hot mix refers to bituminous concrete mixed and placed at high temperatures using bituminous cement as the binder.

**Hot recycling**

Hot recycling is the reuse of old asphalt concrete pavement to make new asphalt concrete through the addition of some new mix constituents and heating at an asphalt plant.

**Hydroplaning**

Hydroplaning is the process by which a vehicle tire on a saturated surface reaches a sufficient velocity to develop enough pressure to raise the tire off the pavement surface.

**Linear cracking**

These cracks normally divide the slab into two or three pieces and are usually caused by a combination of repeated traffic loading, thermal gradient curling, and repeated moisture loading. (Slabs divided into four or more pieces are counted as Divided Slabs.)

**Macadam**

A pavement layer containing essentially one-size coarse aggregate choked in place with an application of screenings or sand; water is applied to the choke material for water-bound macadam. Multiple layers must be used.

**Partial-depth patch**

Partial-depth patches are used to repair surface defects in PCC pavement requiring removal of material up to approximately one-half the slab thickness.

Deeper repairs or areas with exposed steel should be repaired with a full-depth patch.

**Permafrost**

Permafrost is the in situ soil in very cold climates which will remain frozen unless the top insulating soil layers are removed.

**Popouts**

The breaking away of small portions of a concrete surface due to localized internal pressure which leaves a shallow, typically conical, depression; small popouts leaves holes up to 10 mm in diameter, medium popouts leave holes 10 to 55 mm in diameter, large popouts leave holes greater than 50 mm in diameter.

**Porous friction course**

Porous friction course is an asphalt concrete mixture composed mainly of one aggregate particle size (gap graded), with few fines and a relatively large amount of asphalt cement. It is used as a thin (<1 in.) surfacing to prevent hydroplaning.

**Punch out**

A punch out for pavements occurs in continuously reinforced concrete pavements (CRCP). Closely spaced transverse and longitudinal cracks occur and deteriorate until small blocks of PCC can be dislodged under traffic.

**Recycled materials**

recycled materials are existing materials which are reused in some form to produce material for the construction of bituminous or concrete pavement structures.

**Rejuvenators**

Rejuvenators are generally sold as proprietary products. They are designed to reenliven or rejuvenate old, oxidized asphalt cement on the pavement surface. Sprayed on the pavements surface they normally penetrate and rejuvenate the top V4 in. of the pavement surface.

**Rigid pavement**

Pavement that will provide high bending resistance and distribute loads to the foundation over a comparatively large area. Usually

constructed of Portland cement concrete.

**Rutting**

A rut is a surface depression in the wheel path. Pavement uplift may occur along the sides of the rut; however, in many instances ruts are noticeable only after a rainfall, when the wheel paths are filled with water. Rutting stems from a permanent deformation in any of the pavement layers or subgrade, usually caused by consolidation or lateral movement of the materials due to traffic loads. Significant rutting can be lead to major structural failure of the pavement.

**Scaling**

Local flaking or peeling away of the near-surface portion of hardened concrete or mortar. Note: light scaling of concrete does not expose coarse aggregate; medium scaling involves loss of surface mortar to 5 to 10 mm in depth and exposure of coarse aggregate; severe scaling involves loss of surface mortar to 5 to 10 mm in depth with some loss of mortar surrounding aggregate particles 10 to 20 mm in depth; very severe scaling involves loss of coarse aggregate particles as well as mortar generally to a depth greater than 20 mm.

**Sheepsfoot roller**

A compaction roller with drums from which metal projections (resembling sheep feet) extend for several inches. These projections or feet compact soil from the bottom to the top and the soil is compacted when the roller "walks out." This roller is used for fine grained soils (cohesive).

**Skin patch**

A skin patch is a thin bituminous concrete patch placed on an already compacted bituminous concrete surface.

**Slab**

A flat, horizontal or nearly so, molded layer of plain ore reinforced

concrete, usually of uniform but sometimes of variable thickness, either on the ground or supported by beams, columns, walls, or other framework.

**Slabjacking**

The process of either raising concrete pavement slabs or filling voids under them, or both, by injecting a material (cementitious, noncementitious, or asphaltic) under pressure.

**Sod**

Sod is a thin layer of soil bound by a grass and root system.

**Spall**

A fragment, usually in the shape of a flake, detached from a larger

mass by a blow, by the action of weather, by pressure, or by expansion within the larger mass; a small spall involves a roughly circular depression not greater than 20 mm in depth and 150 mm in any dimension; a large spall, may be roughly circular or oval or in some cases elongated, is more than 20 mm in depth and 150 mm in greatest dimension.

**Squeegee**

A squeegee is a blade of rubber, leather, or flexible metal that is attached to a handle and used for spreading, pushing, or wiping fluid materials across pavement surfaces.

**Subbase**

A layer in a pavement system between the subgrade and the base course, or between the subgrade and a portland-cement concrete pavement.

**Subgrade**

The soil prepared and compacted to support a structure or a pavement system.

**Urea**

Urea is a nitrogenous compound used as a deicing material.

**Wearing surface**

The surface material which is designed to carry the traffic on the pavement structure.

## INDEX

This index is organized alphabetically by topic and by subtopic within a topic. Topics and subtopics are identified by paragraph number.

- Admixtures, 4-2b(4)**
- Aggregate spreader, 3-6t**
- Asphalt, 3-5h**
- Asphalt cement, 3-5i**
- Asphalt concrete, 3-1a**
- Asphalt kettle, 3-5i and 3-6s**
- Base course, 2-1a and 2-4**
- Bituminous concrete, 1-3**
- Bituminous pavements, 3-1**
- Bituminous distributor, 3-2a(1) and 3-6r**
- Blade plow, 9-3a**
- Bleeding, 3-4b**
- Blowup/buckling, 4-4a**
- Broom, 3-6a**
  - Circular, 3-6a
  - Vacuum, 3-6
- Caliche, 2-5e(2)**
- Cement, 4-5b**
- Cement, 4-5b**
- Check dams, 7-4(2)**
- Clays, 2-2a**
- Cold mix, 3-5n**
- Concrete pavements, 4-1**
- Corrugation, 3-4e**
- Coral, 2-5e(1)**
- Corner break, 4-4b**
- Cracking**
  - Alligator, 3-4a
  - Block, 3-4c
  - Edge, 3-4g
  - Linear, 4-4h
- Longitudinal, 3-4j**
  - Reflective, 3-4h and 3-4j
  - Shrinkage, 4-4r
  - Slippage, 3-4r
  - Transverse, 3-4j
- Crazing, 4-4q**
- Culvert, 7-2b(3)**
- Depression, 3-4f**
- Divided slab, 4-4c**
- D Cracking, 4-4d**
- Drainage, 7-1**
- Endwall, 7-4c(3)**
- Epoxy, 4-5d**
- Erosion, 73a**
- Expansive soils, 2-2c**
- Faulting, 4-4e**
- Flexible pavement, 2-1a**
- Hammer mill, 3-6n**
- Headwall, 7-4c(3)**
- Heater scarifier, 3-6k**
- Hot mix, 3-5m**
- Ice, 9-2b**
- Jackhammer, 4-6g**
- Joint heater, 3-6i**
- Joint plow, 4-6j(1)**
- Lane/shoulder dropoff, 3-4i and 4-4g and 4-4g**
- Lime, 5-2c(2)(d)**
- Milling machine, 3-6m**
- Patching**
  - Full-depth, 3-7d and 4-7a(2)
  - Partial-depth, 3-7c and 4-7a(1)
  - Utility cut, 3-4k and 4-4i
- Permafrost, 2-2f**
- Polished aggregate, 3-41 and 4-4k**
- Popouts, 4-4l**
- Portland cement concrete, 1-3**
- Potholes, 3-4m**
- Pouring pots, 4-6j(8)**
- Preventative maintenance, 10-1**
- Pulverizer, 3-6o**
- Pumping, 4-4m**
- Punch out, 4-4n**
- Raveling, 3-4u**
- Recycling**
  - Cold, 3-2h(2)
  - Hot, 3-2h(3)
  - Surface, 3-2h(1)
- Rejuvenator, 3-5p**
- Rigid pavement, 216**
- Riprap, 7-4c(4)**
- Roller**
  - Steel-wheel, 5-5b(3)(d)
  - Rubber tired, 5-5b(3)(b)
  - Sheepsfoot, 5-5b(3)(a)
  - Vibratory, 5-5b(3)(c)
- Rotary plow, 93b**
- Rutting, 3-4p**
- Sandblasting, 4(4)**
- Scaling, 4-4p**
- Scour hole, 7-3a(2)**
- Shoving, 3-4q**
- Silts, 232b**
- Slabjacking, k**
- Slabjacking, 4-6k**
- Slides, 73d**
- Slurry seal, 4-7g(4)**
- Snow, 9-2a**
- Snow fences, 9-4b**
- Spalling**
  - Corner, 4-4s
  - Joint, 4-4t
- Squeegee, 3-6d**
- Subbase, 3**
- Subgrade, 2-2**
- Swell, 3-4s**
- Tars, 35q**
- Terraces and levees, 7-4c(1)**
- Tuff, 25e(3)**
- Urea, 9-5c(3)(a)**
- Weathering, 3-4t**

The proponent agency of this publication is the Office of the Chief of Engineers, United States Army. Users are invited to send comments and suggested improvements on DA Form 2028 (Recommended Changes to Publications and Blank Forms) to HQUSACE (CECPW-ER), FORT BELVOIR VA 22060.

By Order of the Secretaries of the Army, the Navy, and the Air Force:

DENNIS J. REIMER  
*General, United States Army*  
*Official: Chief of Staff*

YVONNE M. HARRISON  
*Administrative Assistant to the*  
*Secretary of the Army*

EUGENE A. LUPIA  
*Major General, United States Air Force*  
*Official: The Civil Engineer*

Official

J. E. BUFFINGTON  
*Rear Admiral, RADM, USN CEC*

DAVID J. NASH  
*Rear Admiral, CEC, USN*  
*Commander, Naval Facilities*  
*Engineering Command*

Distribution:

*Army:* To be distributed in accordance with DA Form 12-34-E requirements for TM 5-6000 series nonequipment technical manuals.

*Air Force:* F

RECOMMENDED CHANGES TO EQUIPMENT TECHNICAL PUBLICATIONS



THEN... JOT DOWN THE DOPE ABOUT IT ON THIS FORM, CAREFULLY TEAR IT OUT, FOLD IT AND DROP IT IN THE MAIL!

**SOMETHING WRONG WITH THIS PUBLICATION?**

FROM: (PRINT YOUR UNIT'S COMPLETE ADDRESS)

DATE SENT

PUBLICATION NUMBER

PUBLICATION DATE

PUBLICATION TITLE

BE EXACT... PIN-POINT WHERE IT IS

PAGE NO.	PARA-GRAPH	FIGURE NO.	TABLE NO.
----------	------------	------------	-----------

IN THIS SPACE TELL WHAT IS WRONG AND WHAT SHOULD BE DONE ABOUT IT:

TEAR ALONG PERFORATED LINE

PRINTED NAME, GRADE OR TITLE, AND TELEPHONE NUMBER

SIGN HERE:

DA FORM 2028-2  
1 JUL 79

PREVIOUS EDITIONS ARE OBSOLETE.

P.S.—IF YOUR OUTFIT WANTS TO KNOW ABOUT YOUR RECOMMENDATION MAKE A CARBON COPY OF THIS AND GIVE IT TO YOUR HEADQUARTERS.

**PIN: 005246 - 000**