

TECHNICAL MANUAL

**FIREFIGHTING AND RESCUE PROCEDURES  
IN THEATERS OF OPERATIONS**

---

HEADQUARTERS, DEPARTMENT OF THE ARMY

APRIL 1971

## ACKNOWLEDGMENTS

Acknowledgment is gratefully made to the organizations listed below for permitting us to use their copyrighted material in this manual,

### ***American National Red Cross***

Figures 4-81, 4-84, and 4-87.

### ***Fire Service Extension Department, University of Maryland***

Data on breathing apparatus, including figures 2-3, 2-4, 2-5, 2-6, 2-7, **2-8, 2-9, 2-10, 2-11, 2-12**, and 2-13; data on carbon dioxide and combustible metal agents, including figures 2-60 and 2-67; data on couplings, including figures 2-19, 2-20, 2-21, 2-23, 2-24, 2-25, 2-26, 2-27, 2-28, 2-29, 2-30, 2-31, 2-32, 2-33, 2-34, 2-35, 2-36, 2-37, 2-38, 2-39, 2-40, 2-41, 2-42, 2-43, 2-44, 2-45, 2-46, 2-47, 2-48, and 2-49; data on hose loads, including figures 4-2, 4-3; 4-4, 4-5, 4-6, 4-7, 4-9, 4-10, 4-11, 4-12, 4-13, **4-14**, 4-16, 4-17, and 4-18; the following figures on rope: 2-53, 2-54, 2-55, and 4-26.

### ***National Fire Protection Association***

Reproduced by permission from the ***Fire Protective Handbook***, 13th Edition, Copyright National Fire Protective Association, Boston, Massachusetts. Data from the following:

***Basic Definitions and Properties***-ignition and combustion, flammable or explosive limits, flammable (explosive range, flash point, and fire point).

***Principles of*** Fire-ignition and combustion.

***Heat Energy*** Sources-chemical heat energy, heat of combustion, spontaneous heating, heat of decomposition, heat of solution, electrical heat energy, resistance heating, induction heating, dielectric heating, heating from arcing, static electricity heating, heat generated by lightning, mechanical heat energy, friction heat, heat of compression, nuclear heat energy.

### ***Reuben H. Donnelley Corporation***

Reproduced by permission from ***The Fire Chief's Handbook***, Third Edition, 1967, New York, The Reuben H. Donnelley Corporation. Data on the chemistry and physics of combustion, simple fire triangle, tetrahedron of fire, modernizing the fire triangle, and figure 3-2.

TECHNICAL MANUAL }  
No. 5-315

**HEADQUARTERS  
DEPARTMENT OF THE ARMY  
WASHINGTON, D.C., 20 April 1971**

**FIREFIGHTING AND RESCUE PROCEDURES  
IN THEATERS OF OPERATIONS**

	<b>Paragraph</b>	<b>Page</b>
<b>CHAPTER 1. INTRODUCTION</b>		
Section I. General -----	1-1-1-4	1-1-1-2
II. Organization -----	<del>1-5-1-7</del>	1-2-14
III. Facilities -----	1-8-1-14	1 4 1 - 6
IV. DA forms, reports, and records -----	<del>1-15-1-17</del>	1-6-1-7
V. Communications -----	1-18-1-24	1-7-1-12
<b>CHAPTER 2. CLOTHING AND EQUIPMENT</b>		
Section I. Clothing -----	<del>2-1-2-3</del>	2-1-2-3
II. Fire apparatus -----	2-4, 2-5	2-3, 2-4
III. Tools, appliances, and knots -----	2-6-2-16	2-8-2-27
IV. Fire extinguishers -----	2-17-2-28	<del>2-28-2-34</del>
<b>CHAPTER 3. CHARACTERISTICS, CHEMISTRY, AND PHYSICS OF FIRE</b> ----	3-1-3-6	<del>3-1-3-5</del>
<b>4. TACTICS AND TECHNIQUES OF FIREFIGHTING</b>		
Section I. Fire control -----	4-14-3	4-14-2
II. Fire department hydraulics -----	<del>4-4-4-17</del>	4-248
III. Hose, ladder, and pumper drills -----	4-18-4-36	<del>4-8-4-39</del>
IV. Action on arrival, sizeup, and forcible entry -----	4-374-39	4-39447
V. Ventilation and salvage -----	4-46-446	4-474-65
VI. Rescue operations -----	4-47-4-53	<del>4-55-4-60</del>
VII. First aid -----	4-544-68	4-66-4-74
VIII. Control, extinguishment, and overhaul -----	4-69-4-72	4-744-76
IX. Investigation and return to service -----	4-73479	4-77-4-81
<b>CHAPTER 5. AIRCRAFT FIREFIGHTING AND CRASH RESCUE</b>		
Section I. Introduction -----	<del>5-1-5-4</del>	<del>5-1-5-2</del>
II. Aircraft fire hazards -----	<del>5-5-5-17</del>	<del>5-2-5-14</del>
III. Emergency procedures -----	<del>5-18-5-26</del>	<del>5-14-5-78</del>
<b>CHAPTER 6. NUCLEAR WEAPON FIREFIGHTING PROCEDURE</b>		
Section I. Introduction -----	<del>6-1-6-1</del>	6-1
II. Responsibilities and safety factors -----	6-3-6-13	6-1-6-3
III. General firefighting guidelines -----	6-14-6-16	6 4 6 - 5
IV. Fires involving nuclear weapons -----	6-17-6-23	6-5-6-8
<b>CHAPTER 7. MISCELLANEOUS FIRES</b> -----	7-1-7-11	7-1-7-11
<b>8. FIRE PREVENTION</b> -----	8-1-8-19	<del>8-1-8-8</del>
<b>APPENDIX A. REFERENCES</b> -----		A-1
<b>B. ARMY AIRCRAFT DESIGNATIONS AND FUELS</b> -----		B-1
<b>INDEX</b> -----		Index-1

## CHAPTER 1

## INTRODUCTION

## Section I. GENERAL

## I-1. Purpose and Scope

**a.** This manual is a guide and basic reference for firefighting teams and other personnel engaged in fire prevention, firefighting, and rescue procedures at military establishments in theaters of operations. It covers the policies and procedures, equipment, characteristics and chemistry of fire, tactics and techniques of firefighting, first aid, rescue, and fire prevention. It is concerned primarily with structural, aircraft, petroleum and unclear weapon fires, but also discusses explosive, motor-vehicle, and natural cover fires.

**b.** The material contained herein is applicable to both nuclear and nonnuclear warfare

## 1-2. Changes

Users of this manual are encouraged to submit recommended changes or comments to improve the manual. Comments should be keyed to the specific page, paragraph, and line of the text in which the change is recommended. Reasons should be provided for each comment to insure understanding and complete evaluation. Comments should be forwarded directly to Office Chief of Engineers, ATTN: ENGMC-FF, Washington, D.C., 20314.

## 1-3. What the Fire Protection Specialist Must Know

Progress in fire protection within the Army has increased greatly in the last few years. This progress was brought about by the development of new techniques and more efficient equipment. But offsetting this progress, to some extent at least, is the turnover of military personnel. This turnover is a serious drawback to efficiency, but broad training programs, which include the study of chemistry, physics, mathematics, and building construction, now make the firefighter's training a continuing process.

**a. Chemistry.** The creation and spread of fire is a chemical reaction involving flammable vapors.

Since this reaction can occur under many conditions and circumstances, the firefighter must know the characteristics of fuels and other materials. He gains knowledge through an understanding of the chemistry of fire.

**b. Physics.** Physics involves the principles of mechanics, electricity, heat, light, and sound. The firefighter needs mechanical knowledge to enable him to operate the fire trucks and associated equipment, and to maintain them so they will always be ready for use. Electricity is a common source of fire. In addition, there is a danger of electrocution, especially in the presence of water, and water is the common extinguishing agent. Heat is a major consideration in the spread of fire and in the physical limitations of personnel. Light is necessary to combat fires at night or in inclosed or **smoke-filled** compartments. Sound (the basis of alarm systems) is the foundation of fast and efficient response to emergencies.

**c. Mathematics.** The firefighter must know the mathematical formulas used to determine the proper volume and force of extinguishing agents needed. His knowledge of fire department hydraulics enables the engineer, or pump operator, to arrive at the correct nozzle pressure. An error here may cause injuries, extensive water damage, or unnecessary fire losses. Too much water pressure at the nozzle has been known to throw firemen from ladders or out of windows. Wild hose lines can seriously injure or kill people who are struck by the heavy nozzle or hose couplings.

**d. Construction.** A basic knowledge of building construction is essential for proper forcible entry, rescue, ventilation, or extinguishment. Buildings that look identical on the outside may collapse or burn with great variations of time because of differences in internal design and type of construction. Men who make fire inspections should become familiar with the construction of each building so that in case of fire they will know the approximate length of time the building is safe to

enter and the time at which it must be evacuated before it collapses.

**1-4. Policies and Procedures**

It is important that a member of a fire protection unit be familiar with the most common policies

and procedures of the fire protection organization of the Army, and the forms used. The policies and forms are described in detail in many Army publications. It is the purpose of this chapter to acquaint the firefighter with those general principles which are important in the proper performance of his duties.

**Section II. ORGANIZATION**

**1-5 Fire Protection**

Firefighting science is divided into three phases: fire prevention, rescue, and fire fighting.

a. **Fire Prevention.** This phase establishes standards and practices for the prevention of accidental fires. These standards and practices are controlled by frequent surveys and inspections. Responsibility for inspections and for recommending corrective action is placed in the fire protection organization.

b. **Rescue and Firefighting.** On arriving at a fire, firefighters must determine the exact location of the fire and then act to rescue people, protect exposures, confine the fire, and then extinguish it. While rescue is not needed at most fires, it must be the first concern. The firefighters must stop the spreading of the fire (protect exposures or confine) to other buildings or parts of the building on fire before they can apply themselves to the extinguishment of the fire. Ventilation (removal of smoke, heat, and gases) is a part of the salvage effort which may be required at any time during the firefighting operation. After the fire has been extinguished, a final search is made for glowing spark and embers. This search and the extinguishment of the rekindling potential are known as overhaul.

**1-6. Firefighting Units**

The firefighting units provide fire prevention service and protective measures in addition to extinguishing fires. They also train auxiliary firefighters, maintain firefighting equipment, and advise higher commanders of fire defense plans. The firefighting units consist of four types of teams. They may be attached or assigned as required to fixed strength units or may be organized into service units (TOE 5-510G). These service units are designed to provide different-size organizations with firefighting team's, depending on the tactical and logistical considerations involved. Command and administrative control are normally provided by the firefighting headquarters team.

**a. Team FA, Firefighting Headquarters.**

(1) **Capability.** Capable of planning for overall area fire prevention and firefighting program and for controlling assigned or attached firefighting teams.

(2) **Basis of allocation.** Normally one per three to five firefighting teams (FB and FD) and one water truck team(FC).

(3) **Strength.** Aggregate-4, as follows:

Number	Grade	MOS
1	LT	9414
2	E6(NCO)	51M40
1	E3	70A10

(4) **Mobility.** 100 percent mobile.

(5) **Major items of equipment.**

**Weapons**

Individual weapons only.

**Vehicles**

Trailer, cargo, ¼ T	1
Truck, cargo, ¾ T	1
Truck, utility, ¼ T	1

**Other equipment**

Blanket, fire, wool, w/grommets and rope handle	2
Extinguisher, fire, carbon dioxide, 15 lb (6.76 kilograms)	2
Extinguisher, fire, dry chemical, 20 lb (9.072 kilograms)	2
Extinguisher, fire, foam, 2½ gal (9.46 liters)	2
Firefighting equipment set, repair of extinguishers and fire hose	1
Light, warning, vehicular, red, w/blinker device	2
Repair and refill kit, carbon dioxide fire extinguisher	1
Siren, electric motor operated	2
Telephone set, TA-312/PT	1

(6) **Method of operation.** Team leader serves as the fire marshal of the installation or area of responsibility. Team members conduct fire prevention inspections and train volunteer personnel in firefighting operations. In addition to planning for overall fire defense and commanding firefighting teams, this team maintains and refills fire extinguishers and makes minor repairs to fire hose.

**b. Team FB, Fire Truck.**

(1) **Capability.** Capable of providing fire protection, administering timely and adequate first aid, and implementing a fire prevention program for areas housing 5,000 to 10,000 troops, or a warehouse and open storage area of 100,900 square feet (9290 square meters).

(2) **Basis of allocation.** One per installation housing 5,000 to 10,000 troops, or containing 100,000 square feet (9,290 square meters) of warehouse and open storage.

(3) **Strength.** Aggregate—6, as follows :

Number	Grade	MOS
1	E-5 (NCO)	51M40
1	E4 (NCO)	51M40
3	E-4	51M20
1	E-3	51M20

(4) **Mobility.** 100 percent mobile.

(5) **Major items of equipment.**

**Weapons**

Individual weapons only.

**Vehicles**

Firefighting equipment set, truck mounted, structural type, overseas, class 530B or 530C ----- 1

**Other equipment**

Blanket, fire, wool, w/grommets and rope handle ----- 2

(6) **Method of operation.** Team members provide fire protection for the team's assigned installation or area by conducting fire prevention inspections and by fighting fires. See TM 5-225 for radiological decontamination.

**c. Team FC, Water Truck.**

(1) **Capability.** Capable of transporting water for firefighting purposes when not enough water is available near the fire.

(2) **Basis of allocation.** One or more per firefighting headquarters (Team FA) as required.

(3) **Strength.** Aggregate-2, as follows :

Number	Grade	MOS
1	E-4	51M20
1	E-3	51M20

(4) **Mobility.** 100 percent mobile.

(5) **Major items of equipment.**

**Weapons**

Individual weapons only.

**Vehicles**

Truck, tank, water, 2½-T ----- 1

**Other equipment**

No other major items.

(6) **Method of operation.** Team transports water for firefighting when sufficient water is not available. Team members may be used as firefighters.

**d. Team FD, Brush Fire Truck.**

(1) **Capability.** Capable of furnishing protection against grass or brush fires within its assigned area of responsibility when augmented with personnel and additional handtools. Can also be used to a limited degree to combat structural fires.

(2) **Basis of allocation.** One per installation housing 5,000 to 10,000 troops, or containing 100,000 square feet (9290 square meters) of warehouse and open storage.

(3) **Strength.** Aggregate-2, as follows :

Number	Grade	MOS
1	E-5 (NCO)	51M40
1	E-3	51M20

(4) **Mobility.** 100 percent mobile.

(5) **Major items of equipment.**

**Weapon8**

Individual weapons only.

**Vehicles**

Firefighting equipment set, truck mounted, brush type, overseas, class 530 B or 530 C ----- 1

**Other equipment**

No other major items.

(6) **Method of operation.** Team members train personnel of the supported unit in brush firefighting and supervise them when so engaged. Additional handtools (axes, mattocks, brush hooks) must be provided by the supported unit.

1-7. Responsibilities

AR 611-201 lists the duties, skills, and knowledges of the firefighter. Listed below are the primary responsibilities of the fire protection personnel.

**a. Fire Chief.** The fire chief, under the direction of the fire marshal, supervises the fire protection organization, including management of fire suppression and rescue operations, training and pre-fire planning programs, and maintenance of fire equipment, systems, and devices; he also monitors the fire prevention program. He insures that:

(1) Fire vehicles and personnel are in a state of immediate readiness and availability.

(2) Training and fire prevention programs are carried out.

(3) Resources are efficiently utilized.

(4) Duty assignments, equipment maintenance, and operational procedures are accomplished.

**b. Assistant or Deputy Fire Chief.** He assists

the fire chief in carrying out his duties and assumes them in his absence.

c. **Station Chief.** Under the direction of the fire chief, a designated person acts as the station chief. Since no position is **authorized** for his duty, the person assigned will also perform duty as crew chief. He supervises all chiefs assigned to his station. He will—

(1) Implement the policies and regulations of the base fire protection organization and higher headquarters.

(2) Respond with his crews to alarms and emergency calls and insure **adequacy** of fire suppression and rescue operations.

(3) When first to arrive at the scene of an emergency, **assume** command until the arrival of a senior fire authority.

(4) Supervise and assist in training and instructing the crew members and conducting regular drills to maintain efficiency of firefighting and rescue operations.

d. **Crew Chief.** He will—

(1) Supervise operator **inspection** and maintenance of fire vehicles and insure the upkeep and protection of all fire organization property.

(2) Insure the safe arrival of his vehicles, with its full **complement** of equipment and personnel, at the scene of an emergency.

(3) Respond with his crew and equipment to alarms, fires, common emergencies, vehicle **rescue** emergencies, and routine calls, including reciprocal movements as directed.

(4) **When first** to arrive, assume command until relieved by senior fire authority.

(5) Perform the station chief's **duties**, delegated to him or dictated by emergency conditions.

e. **Firefighters.** Each **firefighter** normally is assigned a specific duty related to equipment operation or firefighting and rescue. All personnel, **however**, will be cross-trained and capable of flexible action in a fire situation and rescue emergency. **Firefighters will—**

(1) Keep apparatus, equipment, tools, and uniforms clean and serviceable,

(2) Respond with the assigned unit to **all** alarms and emergency calls.

(3) Extinguish fires and take necessary **precautions** to prevent their being rekindled.

(4) Be careful to avoid unnecessary damage to or **loss** of department property, or injury to himself or other personnel.

(5) Watch for and protect at the scene of a fire all clues or evidence indicating the fire's cause.

(6) Participate in the fire prevention program.

f. **Training of Fire Truck Operators.** Drivers of emergency type vehicles must attain the following minimum test scores:

(1) Emergency judgment test-108.

(2) Road **test—90.**

(3) Individuals not achieving the above minimum qualifications will have their SF Form 46 and Driver Qualification Record DA Form 348 stamped "Limited License."

(4) Refresher training will be provided annually to assure familiarity with emergency operational requirements for the type of vehicle being operated. Specific attention will be given to the understanding of **legal** limitations required by the installation and by local laws.

(6) Any operator of an emergency vehicle who is involved in an accident will have **his** permit suspended, pending completion of remedial driver training.

(6) Any operator of an emergency vehicle who is involved in an accident and is convicted of any moving violation will have his permit revoked.

(7) Should a requirement exist for the driver to be retrained and tested for driving other than emergency vehicles, the driver's permit will be stamped "Army Limited-Not Valid for **Emergency Vehicle.**"

(8) A 'proper entry' will be made on the Driver Qualification Record (DA Form 348) to assure that the above information and qualifications or limitations are known and available to the motor officer in case of reassignment of the driver **or** loss of a permit.

### Section III. FACILITIES

#### 1-8. Introduction

Firefighters often spend 24 hours or more on duty at an assigned locality in order to assure rapid

response to fire alarms. They should be housed in suitable living facilities, when available, including those necessary for comfortable working, **sleep-**

ing, eating, recreation, training, and study. Inadequate facilities can greatly lessen the efficiency of a fire protection organization. When not on duty, firefighters are on call (in case of grave emergencies).

### 1-9. Structural Stations

A structural fire station must be strategically located in the area it is expected to protect.

a. Usually it is centrally located so **that** each portion of the area will have as much protection as possible without **slighting** any other portion. However, when one portion **is** "high risk" in comparison with the rest of the area, the station's location will naturally favor the **high** risk portion.

b. Reasons for considering an area as a "high-risk" include the speed of ignition of the flammable materials located there, the propagation possibilities, and the potential amount of loss if fire occurs. Those portions of an area containing hospitals\ technical buildings, barracks, headquarters buildings, or other buildings in which life and property loss potential is 'greatest are necessarily classified as critical from the standpoint of fire hazard.

### 1-10. Crash Stations

The location of the aircraft fire rescue station is limited to the vicinity of the airfield, but its location even within that limitation is of utmost importance. An aircraft **fire** rescue station must be centrally located. At the same time it must be so positioned that there will be an open view of all aircraft activity-including the flying field, runways, ramp, parking areas, taxi strips, and **dispersal** areas-from the crash station.

### 1-11. Sleeping Quarters

Sleeping or bunking facilities should enable crewmen of both aircraft **fire** rescue and structural organizations to reach the apparatus floor quickly and safely. When the alarm sounds during sleeping hours, a firefighter is expected to awaken, throw back his blanket, spin around and insert both feet into his **boots**, stoop and pull up his pants, run toward the apparatus floor while placing his suspenders over his shoulders, and finally mount the truck, ready for action-all in about **15** seconds. He can do this only if the quarters are so designed that the distance from the sleeping quarters to the apparatus is as short as possible, passageways are wide and clear, and the area is

completely free from obstructions which might cause delay or injury.

### 1-12. Dining Facilities

Dining facilities included in the quarters must be looked upon as a necessity rather than as a comfort or a luxury, because those periods of absence from the fire station for eating greatly reduce the strength of the organization, **even** if only a few persons are absent for a short time.

### 1-13. Heating and Sanitation

Each structural and crash **station** should be properly 'heated and ventilated.

a. The comfort of personnel will insure that the men willingly and efficiently **perform** their inside duties, which include keeping the equipment in excellent condition. Training and study periods are even required of seasoned firefighters to advance or refresh their technical **knowledge**. Personal comfort **is** a necessity to the man who is trying to absorb such knowledge, and proper building temperature is necessary for personal comfort.

b. Shower and latrine facilities are essential to the health, comfort, and cleanliness of all fire protection personnel. These facilities should be placed reasonably **close** to the apparatus floor. After returning from a fire, the men are frequently wet, cold, and dirty, and a shower helps to prepare them rapidly for another possible emergency. While showering, the men should keep boots and pants close by so that in case of alarm they can put them on immediately.

### 1-14. Training Facilities

For the important purpose of practical training, which serves as a proving medium for theories presented in classrooms, a training ground or area should be provided for fire protection crews.

a. The training ground should be located, if possible, in a position from which response to any part of the area may be made in a minimum of time. Training areas must have a supply of water ample to replenish the supply on the vehicles. Trainers and simulated structures **should** be provided to enable actual fire ignition, control, and extinguishment according to the standing operating procedures.

b. Neither the entire aircraft fire rescue crew nor the entire structural crew will be out of service at any one time while attending **the** training



ground. Reasonably ample protection must be immediately available at all times.

c. A reading or study room is a great asset toward maintaining a progressive study or training 'schedule. A 16-millimeter projector should be available from the signal library for showing training films. A set of technical manuals and orders should be furnished along with any other

helpful publications. The study room must be well lighted, comfortable, and inviting, so as to encourage individual study.

d. A storeroom and repair shop, or a combination of the two, should adjoin the fire station so that crew members studying apparatus there, or working there, will not be far from their duty stations.

## Section IV. DA FORMS, REPORTS AND RECORDS

### I-1 5. Introduction

Fire protection and firefighting operations require reports and records. These are used for determining the effectiveness of firefighting and rescue operations; for appraising fire prevention regulations, programs, and training; and for evaluating fire protection engineering, equipment, and devices. The statistical data enable the organization to analyze and evaluate its own conditions and affect it changes to improve its efficiency. Reports are required for any fire incident which involves death or disabling injury to personnel or damage to or destruction of any building, structure, grounds, utility plant or 'system, installed or moveable equipment, aircraft, missile, vehicle, material, supplies, and personal property. Also, technical investigations are necessary for fire incidents to analyze causes, contributing factors, and Sects; and to determine the effectiveness of the measures taken or required to be taken to meet other such emergencies. Records are required for fire protection equipment systems or devices that may be peculiar to an installation. Routine should be made of inspection and hazards.

### I-1 6. Forms

Listed below are forms to be used for inspection's and test of firefighting equipment.

a. *DA Form 253, Fire Extinguisher Record Tag*. DA Form 253 is attached to each installed extinguisher for recording the monthly inspection and recharging.

b. *DA Form 5-1 (Fire Department Individual Run Report)*. This form is designated to give information on responses made by individual fire units. The form lists information on such matters as time of alarm reception and response, type of apparatus dispatched, location and nature of the emergency (or other type response), equipment used, and hose line operation.

c. *DA Form 5-2 (Fire Report)*. This form is designed to furnish information about fire incidents which affect life or real property. It is used to -

(1) Identify the incident and related operations.

(2) Provide close estimates of monetary loss and the damage or destruction of property, material, and equipment.

(3) Indicate the loss of life and the extent and nature of physical injury owing to fire.

(4) Indicate the extent and nature of contingent loss and its effect on the installation mission.

(5) Determine the cause and contributing factors.

(6) Evaluate and improve fire protection organization, personnel, equipment, training, and procedures.

(7) Determine action to be taken to prevent similar occurrences.

d. *DA Form 5-78 (Fire Hose Record)*. This form records the inspection, test, and maintenance of all fire hoses, the type of coupling, and provides a remarks section.

e. *DA Form 5-118 (Annual Dry Pipe Valve Inspection and Tripping Test)*. This form is provided to record tripping, cleaning, and resetting of dry-pipe and deluge valves with their accessories.

f. *DA Form 5-119 (Automatic Sprinkler and Standpipe Equipment, Inspection and Test)*. This form is used for inspection and tests by maintenance personnel. It is completed as the inspection or test is made for operation of sprinklers, valves, and fire pumps.

g. *DA Form 2404 (Equipment, Inspection and Maintenance Worksheet)*. The equipment inspection and maintenance worksheet is used by all personnel performing inspections, preventive maintenance services, diagnostic checkouts, and

equipment serviceability criteria checks. It provides a standard procedure for temporarily recording equipment deficiencies.

### 1-1 7. Records and Reports

Records at the installation level will be prepared by qualified fire prevention personnel and will be approved by the operating agency commander or authorized representative. The forms are to be prepared as authorized in AR 310-1, as applicable, and used to record technical details of operations and tests for the following reports (For additional information, see TM 38-750).

*a. Automatic Sprinkler Water-Flow and Low Air Pressure, Automatic and Manual Fire Alarm System Report.* Complete and permanent records will be kept of the operation of fire alarm systems and of inspections, tests, and services performed. In addition to inspection and test record forms, impairment tags will be provided for use when devices are found inoperable and not immediately repairable.

*b. Fire Hazard Inspection Report.* This is used for either the fire inspection notice or fire hazard inspection report. The procedure to be used can be determined locally. The main reason for using the fire inspection notice is to streamline action and reduce the time required to complete fire inspection requirements. The establishment of good will and cooperation between the fire organization and the activities occupying the structures will reveal that the majority of fire hazard's can be resolved with this procedure. For situations where the fire inspection notice does not prove satisfactory, or is not adequate, the fire hazard inspection report will be used. Regardless of the procedure followed all fire hazards or deficiencies discovered during any inspection which cannot be or are not corrected during the inspection will be recorded. To insure that all hazards recorded on this form are corrected quickly, followup by the fire inspector is necessary. The time allowed to correct the haz-

ards, which can vary from 1 to 72 hours, depending on the potential dangers involved, will be listed on the form.

*c. The Training Timetable.* The training timetable is a simple chart to assist the supervisor in identifying, planning, and scheduling the training needed by his employees. It is a means of recording the operations each employee can perform, the operations in which each employee needs to be trained, and the date when this training should be started. The chart may vary in form and size, depending on the purpose, the size of the work force, and even the complexity of the work itself. It may also be called a training schedule or work chart and its essential features may be incorporated in an operations guide, work distribution chart, or control chart. However, when once prepared, it gives an overall picture of the specific training to be done in that unit. If the training timetable is correctly used, it serves the following purposes:

- (1) Aids in identifying, planning, and scheduling training.
- (2) Checks on the extent to which training is carried out as planned.
- (3) Aids in determining whether there will be a trained staff as needed to accomplish the mission.
- (4) Aids in assigning workers,

*d. Log.* Each fire protection organization will maintain a daily log containing information on duty personnel assignments, vehicle movements and mechanical status, response to fire incidents, emergencies, false alarms, alarms received, alarm transmissions over automatic manual, sprinkler systems, special exercises, names of visitors, injuries to personnel, etc. This log may be typed or prepared by hand on 8 x 10½-inch (20.3 by 26.7-centimeter) bond paper and maintained in a bound notebook. It will be reviewed and approved by the senior officer in charge at the close of each work shift.

## Section V. COMMUNICATIONS

### 1-1 8. Introduction

The fire protection facilities of an installation must include an adequate communications system. This system consists of telephone systems, automatic, manual, and waterflow alarm systems, two-way radios, and visual and aerial signals.

### 1-1 9. Telephone Systems

Facilities for reporting fires on posts, camps, and stations have, at most locations, been standardized.

a. Fires may be reported through the installation telephone system or through a special system

of outside fire reporting telephones installed in boxes, and connected directly to the alarm board at the main fire station.

*b.* External fire-reporting telephones are housed in metal boxes mounted on poles or external walls of buildings, and are placed so that one of them can be reached rapidly and easily from any possible post location. These boxes are painted red and usually have a red target light mounted over them so they will be visible at night.

*c.* To report a fire over the fire reporting telephone, a person must open the box, lift the telephone receiver, and give the information to the alarm board operator.

*d.* In outdoor storage areas where post telephones or fire reporting telephones are widely scattered, signs should be posted throughout the area to show where these fire reporting facilities are located.

## 1-20. Automatic, Manual, and Waterflow Alarm Systems

In the following systems, alarms are transmitted by electrical impulses and recorded on a tape in the central fire station alarm room.

*a. Automatic Fire, Detection and Alarm Systems.* These systems are installed where it is not feasible to install automatic sprinkler systems. Dormitory type combustible buildings with individual sleeping rooms should have automatic fire detection systems.

(1) These automatic fire detection and alarm systems incorporate some devices sensitive to heat, fire, and smoke. These devices cause an electrically operated transmitter to send a coded signal to the fire station alarm system.

(2) Heat-sensitive devices used in fire detection systems may be either fixed-temperature or rate-of-rise thermostats. Fixed-temperature thermostats will actuate the transmitter when a predetermined degree of temperature is created by unusual circumstances. Rate-of-rise thermostats will actuate the transmitter when a fire or other source of heat causes the temperature to rise at a rate faster than normal. The rate-of-rise devices must be used with fixed-temperature devices.

*b. Manual Alarm Systems.* Manual alarm systems are usually installed in areas not provided with sprinkler or automatic fire detection systems. Watchman service is often provided in these areas. Manual alarm boxes are located strategically throughout an area and are usually operated

by opening the box and pulling a lever. (Due to the different types of boxes, the operation will vary.) Only a local alarm is normally provided. Under certain conditions a coded signal may be sent to the fire station alarm system.

*c. Waterflow Alarm Systems.* Waterflow alarm systems are those that transmit a coded signal to the fire station alarm system when a ruptured sprinkler head causes water to flow through the pipes of a sprinkler system. Loss of air pressure in a dry-pipe system will cause a local alarm and may also transmit coded signals to the fire station alarm system.

## 1-21. Fire Department Radios

The provision of two-way radios for structural fire apparatus is not a substitute for a fire alarm system because such radios usually are not available to post personnel for reporting fires.

*a.* Radios installed on structural apparatus are used successfully for issuing detailed and specific orders to fire crews while they are enroute to the scene of an emergency and at any other time when the apparatus is away from the station.

*b.* Radios are usually installed in the smaller, faster vehicles, since these trucks are normally the first to arrive. Upon arrival, auxiliary equipment or additional emergency assistance can be ordered by radio without delay.

*c.* The frequency of radio equipment on the crash rescue apparatus should be the same frequency as the airfield radio tower.

*d.* Portable radios for firefighters are advantageous. They permit firefighters to engage in various activities and be available for fire call.

## 1-22. Radio Terms and Procedures

Several standardized radio terms and procedures must be understood and used by fire crews.

### *a. Terms.*

(1) "Roger" means "received your message."

(2) "Wilco" means "received your message and (where applicable) will comply."

(3) "Say again," "I say again," and "That is correct" are self-explanatory. To correct something said, the word "Wrong" is used, followed by the correction.

(4) "Wait," if used by itself, means "I must pause for a few seconds" and requests the other station to stand by (refrain from transmitting) for a period not to exceed 30 seconds.

(5) If the pause is to be longer (up to 1 minute), the expression "Wait out" is used.

(6) To request an even longer standby period, the expression "Wait — Out," is used in which the blank is replaced by a numeral indicating the number of minutes the other station is requested to stand by.

**NOTE**

Standby periods usually are requested by an operator who **has** to perform a duty that takes his attention away from the transmitter/receiver or who has to handle communications of higher priority or greater urgency. When requested to stand by, a station normally is expected to remain in this status until advised or invited to resume transmission.

**b. Numbers.** To transmit numbers, the following standard pronunciation should be used:

Numeral	Spoken as
0 -----	zero
1 -----	wun
2 -----	too
3 -----	thu-ree
4 -----	fo-wer
5 -----	fi-yiv
6 -----	six
7 -----	seven
8 -----	ate
9 -----	niner

**c. Letters.** When it is **necessary** to identify a letter of the alphabet or to spell a word, the new standard phonetic alphabet should be used:

Letter	Word	Pronunciation
A	ALPHA	(Al fah)
B	BRAVO	(Brah voh)
C	CHARLIE	(Char lee)
D	DELTA	(Dell tah)
E	ECHO	(Eck oh)
F	FOXTROT	(Foks trot)
G	GOLF	(Golf)
H	HOTEL	(Ho tell)
I	INDIA	(In dee ah)
J	JULIET	(Jew lee ett)
K	KILO	(Key loh)
L	LIMA	(Lee mah)
M	MIKE	(Mike)
N	NOVEMBER	(No vem ber)
O	OSCAR	(Oss cah)
P	PAPA	(Pah pah)
Q	QUEBEC	(Kwi beck)
R	ROMEO	(Row me oh)
S	SIERRA	(See air ah)
T	TANGO	(Tanggo)
U	UNIFORM	(You nee form)
V	VICTOR	(Vik tah)
W	WHISKY	(Wiss key)
X	XRAY	(Ecks ray)
Y	YANKEE	(Yang kee)
Z	ZULU	(Zoo loo)

Words not understood will be spelled phonetically. For example, phonetic transmission of "Type 0-5" would be made as follows: "I spell: tango—Yankee-papa-echo, zero-fi-yiv."

**d. Calling Procedure.** To establish communication with other units make the initial call-

(1) Once communication is established, begin each message with the truck's identification and conclude with the proper closing remark. All messages will end in "over" or "out," whichever is appropriate. "Over" means "my transmission is ended ; I expect a response." "Out" means "this conversation is ended, and no response is expected." "Over" and "out" are **never used together** to end a transmission.

(2) Crews should keep radio equipment clean and protected from the weather. Particular care must be given to the condition of the battery, which must be tested frequently and charged when necessary.

**1-23. Hand Signals**

**Standard** throughout the services are the visual signals between the senior man in charge and the pump operator at structural fires. These signals may be given by hand during the day or by flashlight or lantern during the night. They cover most of the orders usually transmitted from the senior man to the pump operator. The pump operator must be constantly on the alert for signals and must acknowledge all signals by repeating them. Standard signals are easily understood since, in most cases, they suggest the action desired. Signals should be **deliberate**, for careless signals may be misunderstood. If necessary, additional signals may be developed to fill special needs. However, they should be distinctly different from standard signals and should be understood by all concerned. The standard hand signals are **charge line, shut off water in line, cease operations, increase pressure, and decrease pressure.**

**a. Charge Line.** During the day this signal is given by raising both arms vertically from the shoulders, palms to the front, and holding them stationary until the signal is acknowledged, as shown in A, figure 1-1. At night it is given by holding a flashlight or lantern in one hand and raising the arm vertically above the head. The beam is directed toward the pump operator and the light swung horizontally above the head, as shown in B, figure 1-1.

**b. Shut Off Water in Line.** This signal is for a temporary shutdown to allow for line repairs or

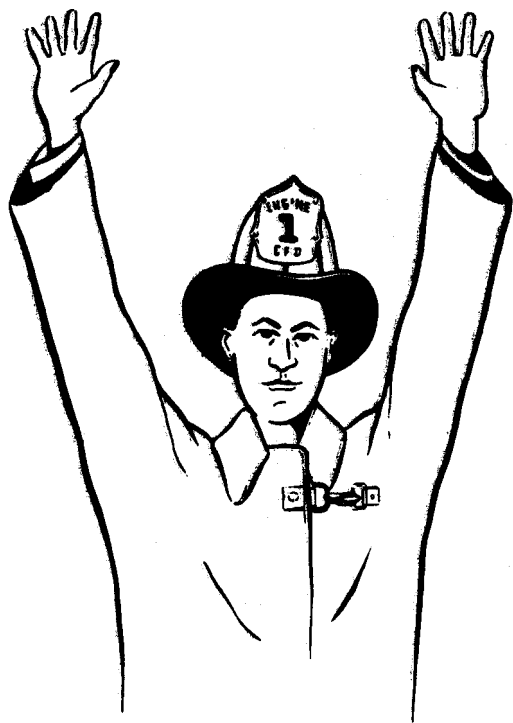

A — DAY



A — DAY

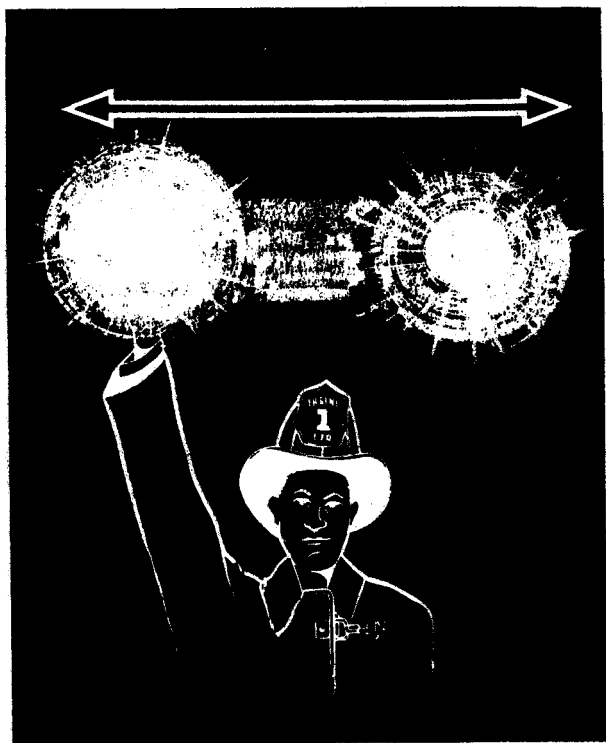

B — NIGHT

Figure 1-1. Charge line.

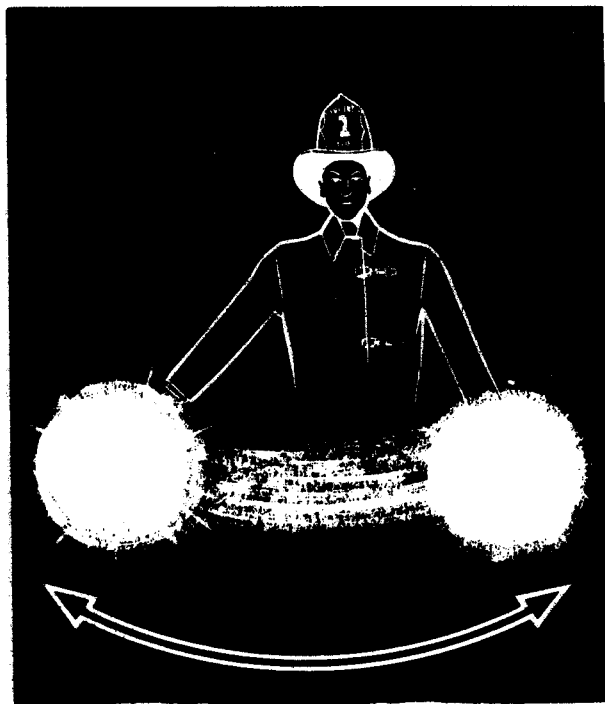

B — NIGHT

Figure 1-2. Shut off water in line.

changes. On receiving it, the operator closes the discharge valve, but continues to pump and holds himself ready to open the valve at the proper sig-

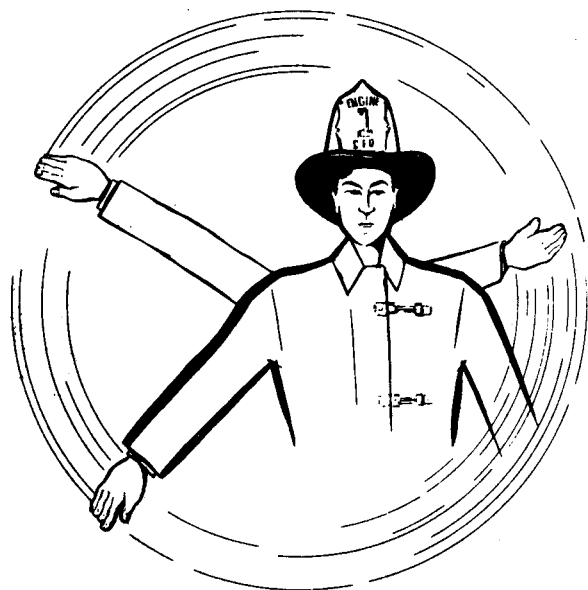

A — DAY

nal. During the day the signal to shut off the water is given by extending both arms downward at an angle of 45°, crossing them in front of the body, and swinging them back and forth, as shown in A, figure 1-2. At night, it is given by extending one arm downward at an angle of 45°, directing the beam of the flashlight or lantern toward the pump operator, and swinging the arm back and forth in front of the body as shown in B, figure 1-2.

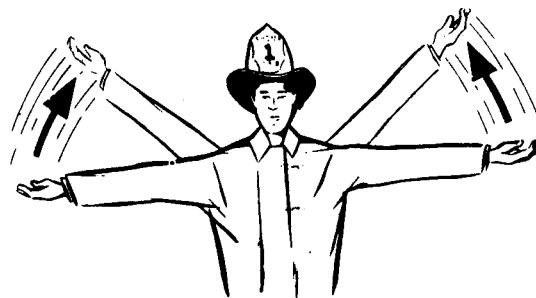

A — DAY

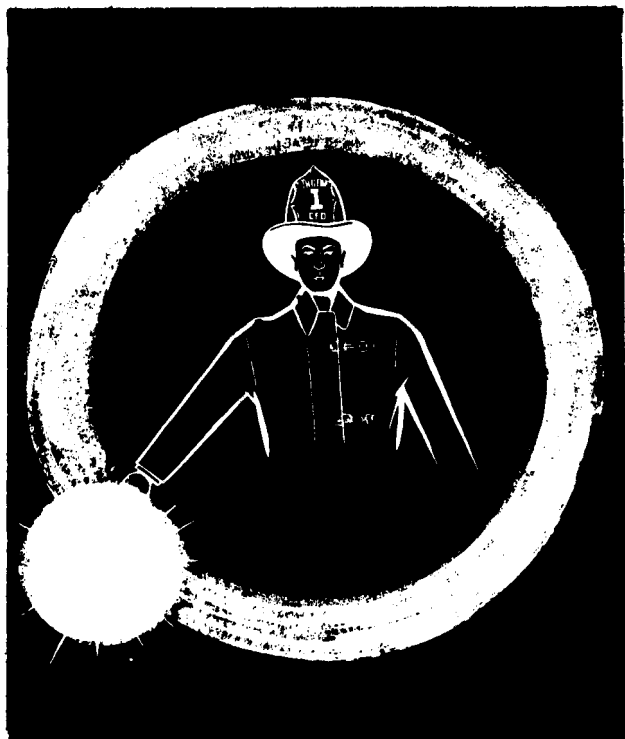

B — NIGHT

Figure 1-3. Cease operations.

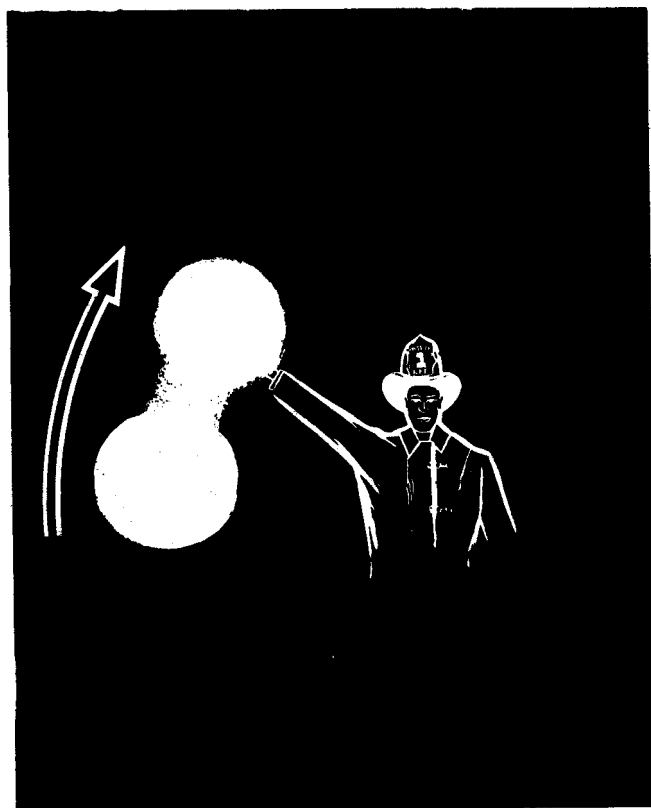

B — NIGHT

Figure 1-4. Increase pressure.

**c. Cease Operations.** This signal means that the operation is over. On receiving it, the operator disengages the pump, **disconnects all lines**, and picks up his equipment. During the day, this signal is given by **describing** a circle in front of the body with an extended arm, as shown in A, figure 1-3. At night, it is given by **holding** a flashlight or

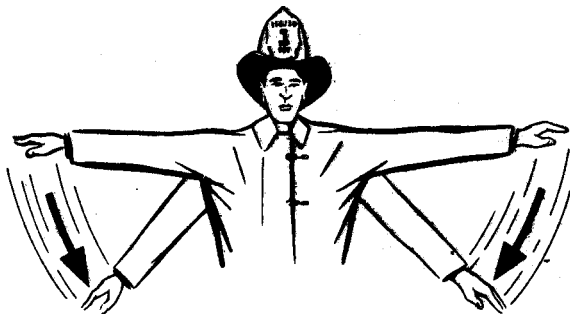

A — DAY

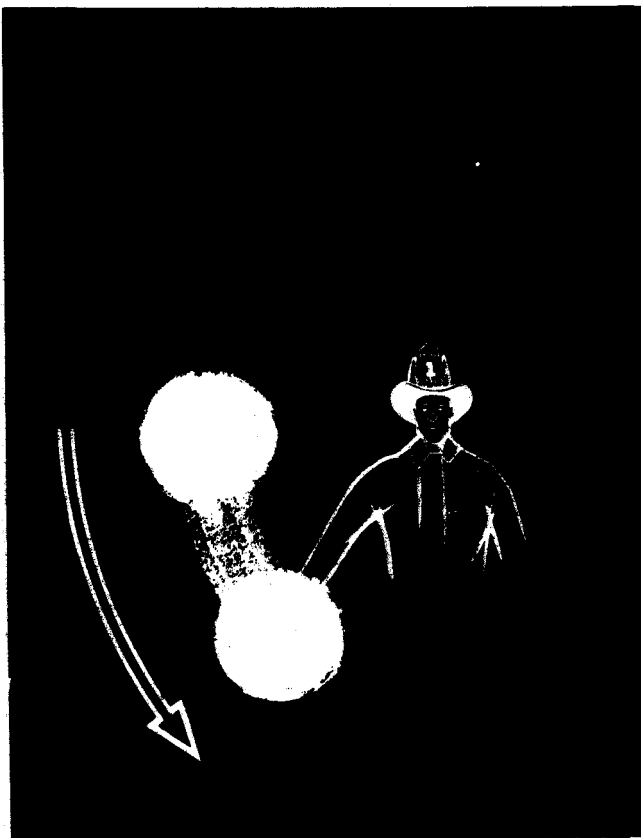

B — NIGHT

Figure 1-5. Decrease pressure.

lantern in the hand and following the same procedure as for daytime, as shown in B, figure 1-3.

**d. Increase Pressure.** This signal is given **once** for each **10 pounds** (4.5 kilograms) increase of pressure required. During the day this signal is given by extending the **arms horizontally** and sideways from the shoulders and raising them to a **45° angle, palms up**, as shown in A, figure 1-4. At night it is given by extending one arm horizontally and sideways from the **shoulders**, holding a light in the hand with the beam directed toward the pump operator, and then raising the arm upward **45°**, as shown in B, figure 1-4.

**e. Decrease Pressure.** Each signal indicates a **decrease** in pump **pressure** of **10 pounds** per square inch (0.7 kilograms per square **centimeter**). During the day the signal is given by extending the arms horizontally from the shoulders and lowering them to a **45° angle, palms down**, as shown in A, figure 1-5. At night it is given by extending one arm horizontally from the shoulder, holding a light in **one** hand with the beam directed toward the pump operator, and then lowering the arm to a **45° angle**, as shown in B, figure 1-5.

**1-24. Other Characteristics of Alarm Systems**

A functional fire alarm system must have the following characteristics.

**a. Distribution** and quantity of the alarm boxes must be such that they can be easily and quickly reached from any possible fire emergency location. The operation must be so simple that persons under the strain of excitement are able to report the location of the fire accurately. Alarms must be transmitted without interference by **nonemergency** communications. The system must be able to operate properly under stress of time and **adverse** climatic conditions. Alarm systems must survive fires and other conditions which may tend to cause a circuit break.

**b.** The most frequent causes of alarm failures and inaccurate impulses **are** the result of falling poles and trees, faulty wiring involving commercial utilities, impact of motor vehicles, wind, sleet, snow, electrical storms, sewer explosions, and excavations which cut or disturb underground wires. To assure the dependability of the alarm systems they must be inspected and **tested** frequently and kept in the optimum operating condition.

## CHAPTER 2

## CLOTHING AND EQUIPMENT

## Section I. CLOTHING

## 2-1. Introduction

Protective clothing provides firefighters with maximum personal safety which enables them to approach and attack fires and perform rescue operations effectively.

a. For normal fires in buildings or in the open, involving basic, ordinary **combustible materials** (wood, paper, stored materials, etc.), the protective clothing issued consists of special fireman's bunker coat and trousers with **suspenders**, plastic helmet, rubber boots, and gloves (fig. 2-1). This clothing, when properly worn, gives reasonable **protection** to the wearer against normal exposures to heat, flames, water, cold, and physical injury without too much sacrifice of body freedom.

b. For more extreme fire-intensity exposure, such as to flammable liquids, liquid or solid fuels and propellants, chemicals, or explosives encountered in typical aircraft or missile fires, special protective clothing must be worn in varying combinations with the normal clothing. Such additional clothing consists of special heat reflective coat and trouser covers and protective head, face, and shoulder hoods.

c. All types of protective clothing are intended to be worn, in various combinations, over and in conjunction with normal personal work clothing, depending upon the climatic, work, and fire conditions.

## 2-2. Normal Protective Clothing

Protective clothing should be put on before leaving the fire station. The following clothing (fig. 2-1) is issued to the firefighter for use in fighting the normal installation fire :

a. **Bunker Coat.** This is a a/a-length coat of special water **repellent** flame-retardant duck outer cloth, with water repellent liner and a **removable** blanket inner lining. Special snap fasteners **pro-**

vide a quick-hitch for putting on the coat. The lining should not be removed except for cleaning.

b. **Bunker Trousers.** These consist of an **over-**trouser of duck cloth and liner, similar to the bunker coat. The trouser legs are designed for rapid donning, and to be worn over fireman's boots. Special waist flap and snap fastening are provided to facilitate securing in place. Trousers are generally worn with heavy duty, quick-hitch suspenders. When not being worn, bunker trousers are normally assembled over boots with suspenders arranged to permit donning in a single movement.

c. **Plastic Helmet.** This is a special-molded plastic safety helmet with cushioned heat strap to provide fit and prevent impact head injury. A chin strap further secures the helmet in place under arduous work conditions. In some **cases**, an additional removable inner liner with ear and back-of-neck flaps is provided. This helmet protects against falling debris, contact with obstructions and, to some **degree**, against water and moderate heat reflection.

d. **Boots.** Rubber boots designed particularly for firemen's use are **hip** length with a steel safety toe cap, flexible punctureproof safety insole of overlapping steel plates, and a heavy corrugated non-slip, grease resistant outer sole. It protects the foot against physical injury and may be worn with equal comfort in both hot and cold **climates**, with variations in socks.

e. **Gloves.** Standard gloves issued for firemen consist of conventional leather shells of **medium-**duty type, with thumb and fingers. These gloves may be worn either separately or in various combinations with cotton, wool, or other fabric or rubber- or synthetic coated or impregnated liners or covers, depending upon personal preferences and local conditions. The leather gloves, while not as water-repellent or heat insulative as some types and combinations, are generally preferred,



since they give reasonable protection and are pliable enough not to hinder the performance of fire-fighting tasks. It is good practice to carry an extra pair in the pocket of the turnout coat. Asbestos gloves, unless treated or worn with some combination of water-repellants, are not recommended because they tend to soak up moisture and create severe internal steaming when exposed to heat.

*f. Protective Clothing Maintenance.* After use, all types of protective clothing should be checked for damage from cuts, abrasions, burns, or wear. Reflective fabrics of coat and trousers are somewhat more likely to be cut and torn, especially when working close to jagged metal such as damaged aircraft. All items of clothing should be flushed off after use to remove any residues of fuels, extinguishing agents, oils, chemicals, dirt.



Figure 2-1. Normal protective clothing.



Figure 2-2. Special protective clothing.

etc. Persistent dirt or other contamination should be removed by washing with soap or mild detergents, water, and a brush. In some cases, mild solvents may be used for cleaning. Tumbling, scrubbing, or abrasive action would be kept to a minimum, particularly for aluminized reflective fabrics. Clothing should be thoroughly dried after cleaning to prevent molding or rotting. Some protective hood models have a special facepiece glass which may be removed for cleaning or replacement. The glass is removed by unfastening one side of the frame and sliding out the glass.

### 2-3. Special Protective Clothing

Special protective clothing is used to fight fires of extreme heat, such as oil, missile, and aircraft fires.

a. *Aluminized Covers.* These consist of separate long coat and trouser covers made of special heat-reflective aluminized cloth, the same material of which the hood and gloves in figure 2-2 are made. This material reflects about 90 percent of all radiant heat when clean. The basic fabric is primarily of noncombustible yarns (minimum 84 percent glass fiber and asbestos), and is not readily ignitable if subjected to flashbacks or contact with splashed burning fuel. When worn over normal bunker coats and trousers, with inner liners removed, they absorb and pass on to the body only about 1/10th as much heat as the normal duck bunker clothing. This combined assembly's weight is about 30 percent less than that of the standard bunker clothing with inner liners, and provides greater freedom of movement, more effective operations, and personal safety. Covers may be worn over normal arctic type clothing when on

standby in extremely cold climates. Combinations of the coat and trouser covers with other clothing allow the wearer to approach closer to a hot fire and stay longer safely without becoming uncomfortable. By proper prearrangement of the reflective covers over bunker coats and trousers, they can be put on in essentially the same time as bunker clothing alone.

b. *Hood.* This is a protective plastic skull casement with a sweatband and braces positioned in the upper portion. To this is fastened a swiveled headpiece of thin, hard, lightweight fire-resistant composition material holding a thick safety, fire-resistant, and heat-reflective glass facepiece (fig. 2-2). The hood assembly—from the skull base in the rear and chin level in the front—is draped with a special asbestos and glass fiber heat- and fire-resistive cloth which drops to the shoulders when worn, to protect the otherwise exposed portion of the head, neck, and face. The entire facepiece-body assembly to the hood, including draped fabric, may be swung away from the face to the top of the hood without moving the skull casement from the hood. Before entering the fire or fuel spill area, wearers should check that the fabric drape is completely down and overlapping the coat at the shoulders. Wearers should also vacate the area and remove the hood or lift the facepiece when they notice vapor inside the hood.

c. *Goggles.* If a mask is not worn which will protect the eyes, shatter resistant goggles should be worn when working with power tools or hand tools in pulling, cutting, or striking operations. Goggles must be of good quality to avoid distorted vision.

## Section II. FIRE APPARATUS

### 2-4. Breathing Apparatus

The body can survive a great deal of external damage, but if breathing stops death will result in a short time. By using the proper breathing apparatus the firefighter will be able to enter and work in many fire atmospheres and carry out rescue operations or attack a fire at its seat. A person working with a breathing apparatus must rely to a great extent on his sense of touch. His vision will probably be restricted by smoke and darkness, and to a certain extent by the mask facepiece itself. It is absolutely necessary that a firefighter is thoroughly trained before he attempts to use breathing apparatus on the fire ground. In

addition, the apparatus used must be of a suitable type and properly maintained.

a. *Rules for Using a Breathing Apparatus.* When working with breathing apparatus, the following rules must be observed.

- (1) Use breathing apparatus only when in good health and physical condition.
- (2) Do not use breathing apparatus when overexerted. Do not use if you have already suffered from exposure to the unbreathable atmosphere.
- (3) Check the operation of the apparatus before entering the fire area.
- (4) Always work in pairs. It is important to

have another trained individual present in case of a malfunction in the apparatus.

(5) When possible, stay in contact with a hose line, or use a life line, so escape can be made quickly if necessary. If you should lose contact with a hose line, find a wall and follow it to a window or doorway. To avoid crawling in circles, feel the flooring. Usually floor boards, seams in carpeting, or cracks in tile flooring can be located. Following these will lead you in a **straight** line to a wall.

(6) Conserve air ; work efficiently and **make** every movement count.

(7) Thorough training and **practice** with the type of breathing apparatus to be used is absolutely necessary.

(8) Recognize the limitations of the equipment. Under fire conditions you will have to move slowly as vision is limited. You cannot work as efficiently with breathing apparatus, but you might not work at all without it.

(9) Allow sufficient time to get out of the area in which you are working when the air supply or the oxygen generating capability of the apparatus is used up.

**b. Breathing Apparatus for General Fire Fighting Use.** The compressed air, self-contained demand type breathing apparatus is the only type apparatus acceptable for use by Army firefighters. This **demand** type compressed air apparatus (fig. 2-3) has a tank of compressed air which is carried by the firefighter and supplies air as he needs it.

**c. The Compressed Air, Self-Contained, Demand Breathing Apparatus.** This breathing apparatus (fig. 2-3) supplies oxygen in the form of compressed air from a cylinder which is carried by the firefighter. Its name reflects the fact that the air from the cylinder is supplied to the wearer through a demand valve as the wearer inhales. This valve regulates the flow of air proportionate to the supply required and reduces the pressure so that it is supplied to the facepiece at or slightly above normal atmospheric pressure. A variety of this apparatus is designed which maintains a slight positive pressure at all times to insure against leakage. This apparatus is called a **pressure demand** breathing apparatus and is similar in operation to the demand apparatus. Operation of the demand valve or regulator is fairly simple. It consists of a large diaphragm which moves in and out with the wearer's inhalation and exhalation. As he inhales, pressure on the diaphragm

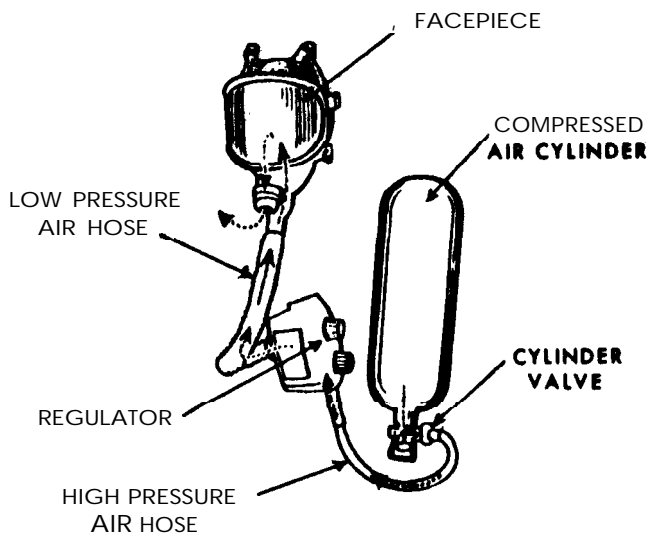

**Figure 2-3.** The compressed air, self-contained demand type breathing apparatus.

decreases and permits air to flow from the cylinder. The diaphragm permits enough air to flow from the cylinder to provide air in the facepiece at or slightly above normal atmospheric pressure. When inhalation stops, the diaphragm moves inward and stops the flow of air from the cylinder. An exhalation valve on the facepiece releases exhaled air to the outside atmosphere. A speaking diaphragm is also located on the facepiece of most apparatus now being manufactured to permit communication without removing the facepiece. The air cylinder is normally carried on the user's back. A cylinder containing about 40 cubic feet (1 cubic meter) of air at a pressure of about 2000 pounds per square inch (140 kilograms per square centimeter), when full, has become standard in the fire service. It will provide 30 minutes of protection under test conditions. When used on the fire ground, conditions will not be exactly the same as during the tests. The air supply may last less than 30 minutes, possibly as little as 15 minutes. Many makes and models of demand breathing apparatus are in use. In all cases, the detailed instructions provided by the manufacturer should be followed carefully when using, maintaining, and repairing the apparatus. The following are general procedures for using this apparatus.

(1) Inspect the apparatus visually to make sure that all parts appear to be in good operating condition.

(2) Check the cylinder pressure gage to be sure the cylinder is fully charged.

(3) Quickly check all straps to make sure they are fully extended.

(4) Check the demand regulator to be sure the main line valve is fully open and the bypass (red) valve is completely closed. The bypass (red) valve permits air to flow directly to the facepiece without being governed by the operation of a regulator. It is used for escape if the regulator fails to function properly. If it is necessary to use the bypass valve, first open it slightly and close the mainline valve. Next, adjust the bypass valve slowly until just enough air is being supplied to the facepiece to permit breathing while escape is made. If the bypass is opened suddenly excessive air pressure reaching the facepiece may cause it to lift and destroy the seal, leaving you exposed to the contaminated atmosphere until the facepiece can be seated to obtain a proper seal again. If both hands are not needed to escape, as they would be in climbing a ladder, it is possible to gain additional escape time by opening and closing the bypass valve as air is needed while you are escaping.

(5) Turn the cylinder valve to the full open position. If the mask is so equipped, set the reserve lever to start.

(6) Insert the left arm through the harness, swing the cylinder assembly on to the back, and insert the right arm through the harness. It is important to insert the left arm through first, to reduce the chance of damaging the regulator by

striking it on something as the harness swings around while placing the cylinder on your back (fig. 2-4).

(7) Take up on the shoulder straps so that the cylinder is positioned well up on the back.

(8) Fasten the chest and waist straps.

(9) Grasp the facepiece between the thumbs and forefinger. Place the chin in the lower part of the facepiece and pull the strap harness back over the head. Tighten the straps by pulling *straight back*, not out to the side, first the lower two straps, next the two side straps. Place the hands on the strap harness and push it back toward the neck. Again tighten the lower straps, then the side straps. They should be snug and not too tight. It should not be necessary to tighten the top strap. Check the fit of the facepiece by placing one hand over the end of the breathing tube and inhaling. The facepiece should collapse against the face.

(10) When ready to enter the structure or the contaminated area, connect the breathing tube to the regulator outlet (fig. 2-5).

(11) When the low air pressure warning device (bell, whistle, or resistance to breathing)



Figure 2-4. Putting on the compressed air, self-contained demand breathing apparatus.

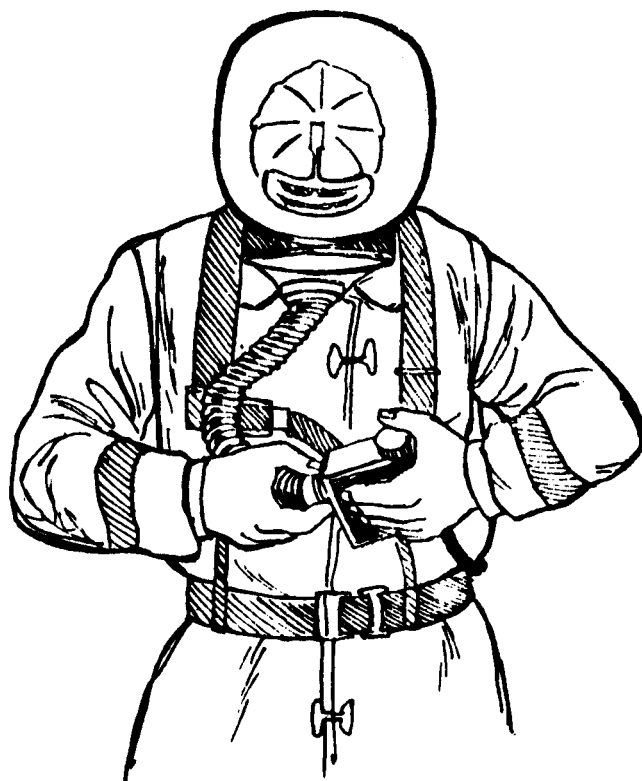

Figure 2-5. Connecting the breathing tube to the regulator outlet.

operates, if the apparatus is so equipped, place the reserve lever in the reserve position, and retreat to a safe and breathable atmosphere at once. Some air pressure will remain in the **cylinder** even after low pressure warning devices have operated and escape has been made. This should be allowed to remain, as a positive pressure in the cylinder will prevent outside air from being forced into the cylinder as the air pressure of the atmosphere changes. This "breathing" would let moisture into the cylinder and could cause rust. **Rusting** of the cylinder might result in cylinder failure under pressure, or the accumulation of carbon **monoxide** within the cylinder.

**d. Breathing Apparatus for Special Situations.** Rescue work in an extremely confined space, work in a remote area of a large building which cannot be reached or withdrawn from in a short time, or prolonged operations on an elevated platform present situations in which special types of breathing apparatus are useful. One of these special types is the **air line** apparatus. It is similar to the demand breathing apparatus, except that air is supplied through a long small **diameter** hose from large compressed air cylinders which are usually mounted on the fire truck. Another special type is the **air hose** apparatus. It supplies air through a large diameter hose from a blower or pump located outside the unbreathable atmosphere. Should the blower fail some air can still be obtained through the large diameter hose.

**e. Limitations of All Breathing Apparatus** Breathing apparatuses are a means of supplying air to the firefighter, but other dangers still exist. In addition to the time limits in which breathing apparatus functions adequately, the firefighter may become exposed to intense heat or toxic gas. Some of the latter can be absorbed through the skin and produce serious health effects.

## 2-5. Fire Trucks

Because of the various firefighting problems common to all Army installations, several types of fire apparatus (trucks) are provided. These trucks have pumping capacities ranging from 300 to 750 gallons per minute (gpm) (1135 to 2650 liters per minute). Factors to be considered in determining apparatus requirements are : location, construction, occupancy, property value, existing safeguards, and availability of outside fire protection assistance. Current models of structural firefighting apparatus used by the Army include class **750A**, class 500, and classes 530B and **530c**.

**a. Class 750A Fire Truck.** These trucks are the largest pumping units authorized.

(1) They are, in general, the same type used by municipal fire departments. They are mounted on a 4 x 2 chassis. (The expression "4 x 2" means that the **truck** has four axle endings and that two of them are power driven.)

(2) Water pressure is provided by a mid-ship-mounted centrifugal type pump, driven by a special gear train or **transfer** unit from the vehicle engine. The pump on a class 750A pumper can supply four **2½-inch** (6,35-centimeter) hose lines at the same time under normal operating conditions. The total pump capacity varies with pressure requirements, as follows : 750 gpm (2839 liters per minute) at 150 pounds (68 kilograms) net pump pressure, 525 gpm (1987 liters per minute) at 200 pounds (91 kilograms) net pump pressure, and 375 gpm (1424 liters per minute) at 250 pounds (113 kilograms) net pump pressure. The booster water tank is mounted in the front end of the hose body and is permanently **connected** to the intake side of the pump. Its capacity is 150 gallons (568 liters).

(3) The hose body can hold from 1,000 to 2,000 feet (305 to 610 meters) of **2½-inch (6.35-centimeter)** double jacketed hose. In addition, the class **750A** fire truck carries 150 feet (46 meters) of 1-inch (**2.54-centimeter**) booster hose permanently attached to the discharge side of the pump. The purpose of the booster tank and the attached 1-inch (**2.54-centimeter**) hose is to enable the firefighting crew to extinguish a small fire in the fastest way possible before it spreads so much as to require a lengthy major layout and loss of considerable time and property. The booster hose may be carried either on a reel or in a compartment basket.

(4) On the class **750A** fire truck the linemen and the **plugman** can ride in the cab behind the driver. **Ladders** and hard suction **hoses** are in compartments on top of the side compartments, all tools and **accessories** are in closed compartments, all pump controls are in closed compartments, and there is a **40-gallon (152-liter)** foam tank located forward of the water booster tank.

**b. Class 500 Fire Truck.** The **class 500** fire truck is commonly used at most **installations**.

(1) It is similar to the class **750A** fire truck except that it is smaller, has less pump capacity, and all tools and equipment are externally mounted. The class 500 fire truck has a 4 x 2 **chassis** and 90 to **100-horsepower** engine. It car-

ries a midship-mounted 500-gpm (1892-liter per minute) pump, a booster water tank, hose body, and all standard firefighting tools and equipment.

(2) The centrifugal pump, driven by a transfer unit from the main engine, can supply two 2½-inch (6.35-centimeter) hose lines within its limits of capacity. It uses a 150-gallon (568-liter) booster tank, 750 to 1,000 feet (229 to 305 meters) of 2½-inch (6.35-centimeter) hose, and a 150-foot (46-meter) 1-inch (2.54-centimeters) booster line hose.

c. **Class 530B Fire Truck** The 530B pumper truck (fig. 2-6) is a 6 x 6, 2½-ton (2.2-metric ton) truck equipped to combat all classes of fires. It has a 500-gpm (1892-liter per minute) midship-mounted pump, a 400-gallon (1514-liter) booster water tank, and 40-gallon (152-liter) liquid foam tank. It can carry 800 feet (244 meters) of 1½-inch (3.8-centimeter) hose and 1,200 feet (366 meters) of 2½-inch (6.35-centimeter) hose. Two hose reels each containing 150 feet (46 meters) of 1-inch (2.54-centimeter) hose are located behind the cab. This truck, like all other fire trucks discussed in this section, has a foam proportioning system for introducing foam into the water discharge. As a self-contained general pur-

pose firefighting vehicle, this truck is completely equipped with portable extinguishers, ladders, floodlights, flashlights, tools, and other accessories commonly known as "removable firefighting equipment." The equipment on this truck, like the equipment on the class 500, is in the open and visible. The pump controls are external and the hosemen ride on the tailboard. See paragraph 1-6 for the different units that may be used with the 530B.

d. **Class 530C Fire Truck.** The 530C (fig. 2-7) is the same as the 530B fire truck, except that the 530C has a turret extinguisher (pump) which permits extinguishment while the truck is moving. The 530C also has a 750-gpm (2839-liter per minute) pump instead of the 500-gpm (1892-liter per minute) pump on the 530B.

e. **Trailer-Mounted Pumping Unit.** The trailer-mounted pumping unit consists of a two-wheel trailer carrying a self-contained 500-gpm (1892 liter per minute) centrifugal pump directly connected to a 90- to 110-hp engine, 300 feet (92 meters) of 1½-inch (3.8-centimeter) hose and 500 to 700 feet (152 to 214 meters) of 2½-inch (6.35-centimeter) hose, and the standard firefighting equipment. The pump does not have a perma-

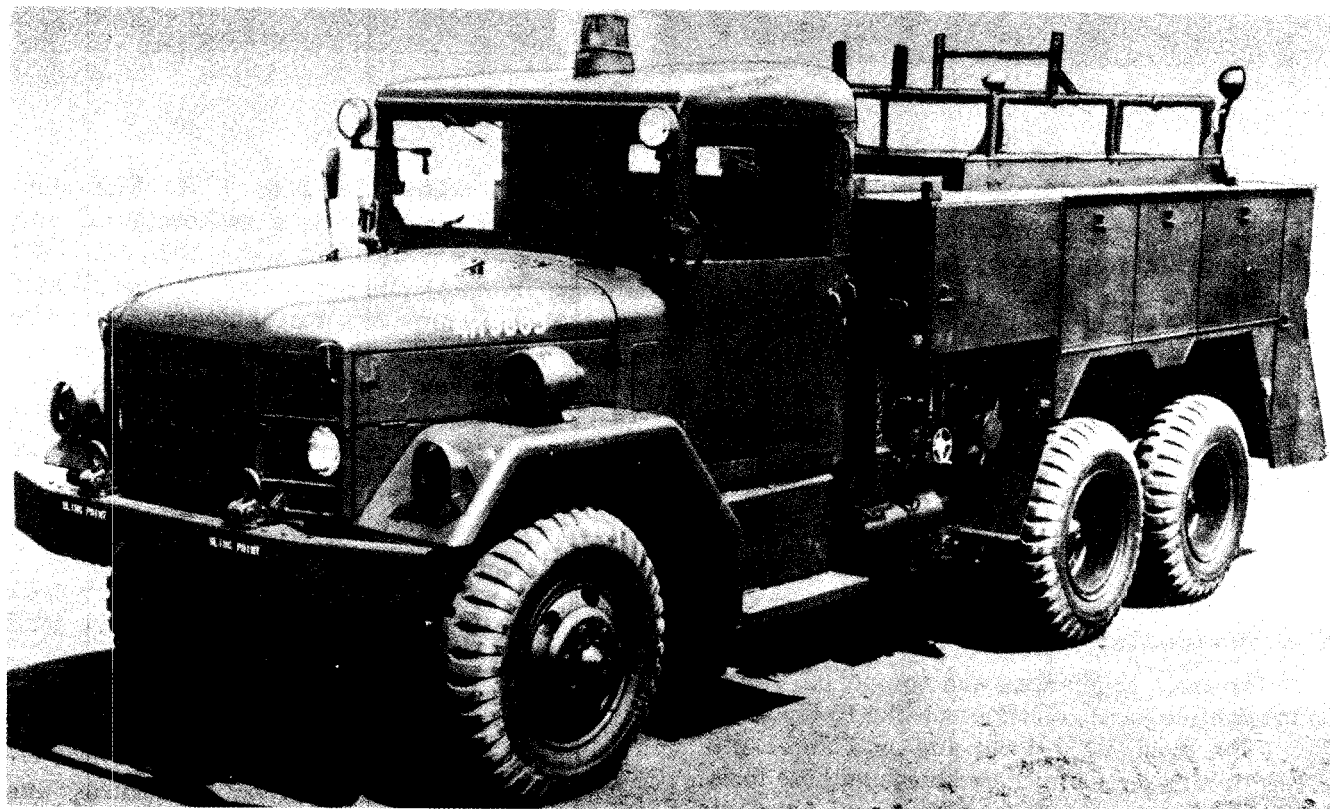

Figure 2-6. 530B fire truck.



*Figure 2-7. 530C fire truck.*

nently installed pressure regulator or **pressure-relief** valve. The pump operator must meet changing firefighting requirements by manually adjusting the controls. The pump can **supply 2½-inch (6.35-centimeter)** hose lines at 500 gpm (1892 liters per minute) at 120 pounds (54 kilograms) net pump pressure, 250 gpm (946 liters per minute) at 200 pounds (91 kilograms) net **pump** pressure, and 167 gpm (632 liters per minute) at 250 pounds (113 kilograms) net pump pressure.

*f. Skid-Mounted Pumping Unit.* The **skid-mounted** pumping unit is a self-contained unit consisting of a powerplant and a **500-gpm** (1892 liter per (minute) pump mounted on a single-skid base. Fire departments may augment the water supply and pressure on such systems by pumping from the hydrant through one or two **2½-inch (6.35-centimeter)** hose lines connected to the fire department (Siamese) connection of the sprinkler system.

### Section III. TOOLS, APPLIANCES, AND KNOTS

#### 2-6. Introduction

a. The tools, appliances, and equipment needed in firefighting vary greatly according to the **situation**. The firefighting tools and appliances discussed in this section include hoses and hose tools, ladders, special tools such as axes and pry-bars, ropes, wrenches, couplings and connections, **salvage** equipment, and lights. It is most important

**that** the firefighter be familiar with all the tools and appliances he may use.

**b.** In addition to itemizing, identifying, and **describing** the types of equipment used, this section also explains operation, safety procedures, and preventive maintenance as they apply to each type of tool and appliance.

## 2-7. Hoses

Hose layouts subjected to any degree of high pressure are always a potential source of danger and may contribute to the failure of an operation. Accidents and failures caused by discharge lines can be prevented if firefighters are well trained in the proper use of hose lines and if complete tests and inspections of hoses and related equipment are made periodically.

a. *Types.* Five types of hose are currently being used by the Army, some much more widely than others. The most widely used type is the cotton-jacket, rubber-lined hose in 2½-inch (6.35-centimeter) and 1½-inch (3.8-centimeter) sizes. Another type used is the rubber-covered, rubber-lined hose, usually in comparatively smaller dimensions, used for finishing lines, booster lines, and high-pressure hoses. A third type is the rubber-lined, wire-reinforced hose, used in operations where rigidity is essential. A fourth type is the unlined linen hose, which is light and pliable but not immediately watertight. The fifth type is the polyester hose. This hose is made of light weight dacron with pin or rocker plug couplings. It comes in standard 50-foot (15-meter) lengths in 1½-inch (3.8-centimeter) and 2½-inch (6.35-centimeter) diameters.

b. *Care of Hose.* Hose is so vital to firefighting operations: that its care must be the responsibility of every firefighter. The following are some of the causes of hose damage and general precautions in handling hose.

(1) Dragging the hose along the ground frequently results in cuts, abrasions, punctures, and damaged couplings, threads, or lugs.

(2) Pulsations in the pump cause the suction and discharge hose sections to vibrate which chafes the hose jackets where the hose touches. Serious hose injury results when these surfaces are rough or have sharp edges. Hose damage is most pronounced near the engine. Farther away, the vibration is absorbed by the elasticity of the hose.

(3) **Vibration** may be almost unnoticed, yet it may weaken the hose so much that it fails in a relatively short time. To prevent this, chafing boots must be inserted between the hose and the ground at the affected points. If chafing boots are not available, burlap, rope cushions, or any suitable substitute may be used. The chafing boot consists of a pad, usually a portion of salvaged hose, which is strapped or clamped to the hard or soft suction hose during pumping operations.

(4) Hose may be damaged by improper operation at the shutoff nozzle. Closing the nozzle quickly causes a sudden increase in pressure which may rupture the hose. If the nozzle is opened quickly, back pressure will increase 50 percent, and the operator may lose control of the hose, which may injure personnel in addition to damaging the hose.

(5) One of the most common causes of hose injury is the result of vehicles being driven over hose layouts. Serious damage is less likely when the hose is charged with pressure. When the hose is empty or under insufficient pressure, the jacket may be separated from the lining or the hose may be ruptured or torn from the coupling. This type of damage can be prevented by hose bridges (fig. 2-8). Two of them should be built and carried on the truck at all times. After the hose lines are laid, the bridges are placed over them at the desired spacing, generally about 4 feet (1.2 meters) apart. If standard bridges are not available, a suitable bridge may be set up with materials found at the scene of the fire. A simple bridge consists of planks, laid on each side of the hose, thick enough to keep the wheels from striking the hose.

(6) When possible, the hose lines should be stretched on the same side of the road as the fire. The lines should be laid parallel to the curb, but not so close to the curb that acid or oil floating down the gutter may come in contact with the hose. When a street or areaway must be crossed, the hose should be laid on the same side of the street as the hydrant, parallel to the curb and up to a point opposite the fire, then across the street. Thus, fire equipment that follows need not travel

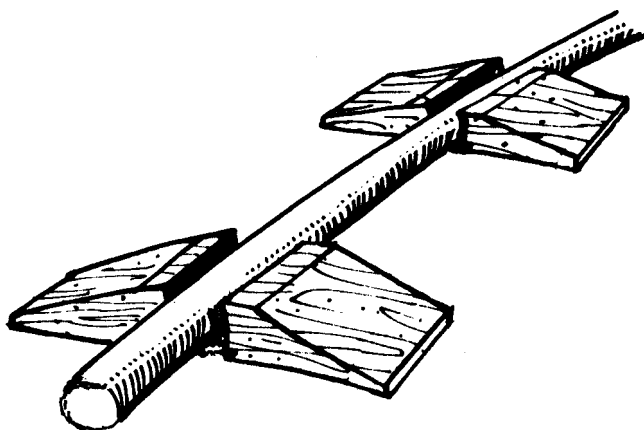

Figure 2-8. Hose bridges.



over the hose unless it is necessary to pass to the far side of the fire.

(7) Where freezing temperatures are common, hose is frequently damaged by rough handling during the winter. When the hose is frozen, the fibers are weakened and the threads which run lengthwise in the hose are warped. A break in the hose will be caused if it is not handled carefully. If the hose is frozen to the ground or street, remove it by carefully chopping away the ice beneath it. Do *not* remove the ice which remains stuck to the hose. Place the hose in the truck with the least possible bending and forcing and take it back to the station. After the frozen hose thaws out, it should be stretched out, washed, and left to dry.

(8) Firehose should not be dropped because this may damage the couplings. When possible, the hose should be carried at the couplings. When hose is carelessly handled, the exposed threads of the male coupling may be damaged so much that efficient connection to the female coupling is impossible. The female coupling is easily knocked out of round, thus making the entire 50-foot (15-meter) length of hose useless in a layout.

(9) Firehose is frequently and unavoidably burned at fires. All hose which has been exposed to fire should be turned in to salvage if extensive damage is found at a considerable distance from either of the couplings. When the damage is close to the coupling, the damaged portion may be cut off and the coupling replaced.

(10) If hot liquids penetrate the cover of the hose, the lining is loosened seriously which weakens the hose. Chemical injury cannot always be prevented, especially at fires at chemical depots and warehouses. In addition, it is almost impossible to detect the presence of injurious chemicals in water that may be flowing from a burning structure. Many acids, even when diluted, can stain and destroy the hose jackets. When acid damage is suspected, each length should be carefully examined for brown or powdery spots. The exposed portions should be washed immediately and thoroughly with baking soda solution and then given a pressure test.

(11) Petroleum products such as gasoline, oils, and greases, upon coming in contact with hose, cause rapid deterioration of the rubber lining by dissolving the cement and loosening the lining from the jacket. When a single hose length is used after having been exposed to lubrication products, the lining tears apart and piles up in

one end of the hose. This causes considerable loss or complete stoppage of waterflow.

(12) Paint and paint thinner are equally harmful to firehose. Consequently, paint should not be used to mark the hose. A thin application of indelible ink with the aid of a stencil should be used. Hose should be cleaned with mild soap and water solution, followed by a thorough rinse in clean water and a complete drying process to prevent mildew. Damp or dirty hose should never be stored. Hose such as the dacron type will not mildew and may be stored wet in warm weather.

*c. Maintenance.* Improper or incomplete maintenance shortens the life of the hose and may result in hose failure at a critical time. Hose maintenance is somewhat complicated because hose components present entirely dissimilar problems. The jacket and rubber lining deteriorate with age regardless of whether or not the hose is used. Rubber deterioration can be delayed if the lining is not allowed to dry rot. If the jacket is kept wet, it is subject to mildew and fungus which destroys the fiber. Keeping the rubber moist and the cotton clean and dry requires frequent handling of the hose, which makes the couplings more liable to damage.

*d. Inspections and Tests.* Fabric-jacket, rubber-lined hose must be inspected daily and after each use.

(1) The after-use inspection includes the removal and inspection of all hose which is wet. After the fabric jacket is cleaned and visually inspected, the couplings should be examined for proper operation and the hose placed on the drying rack. If there is dirt or dampness in the hose bed, the remaining hose should be removed from the truck and replaced with clean, dry hose.

(2) All discharge and suction hoses should be hydrostatically tested seminannually to determine whether each section can withstand operating pressures. Up to six lengths (300 feet (92 meters)) of discharge hose may be tested at one time. One-inch (2.54-centimeter) rubber-covered hose and 1½ (3.8) and 2½-inch (6.35centimeter) double, cotton-jacket, rubber-lined hose should be tested at 150 pounds (68 kilograms) of pressure. Fabric-jacket, rubber-lined 1½- (3.8) and 2½-inch (6.35-centimeter) hose should be hydrostatically tested at 250 pounds (113 kilograms) pressure for 5 minutes. The hard and soft suction hoses should be tested at 100 pounds (45 kilograms) of pressure. The hard suction hose should be vacuum

tested to an 11-pound (5-kilogram) vacuum on the pump and the lining examined for defects. All previously mentioned hose inspection procedures are repeated together with the hydrostatic tests on the semiannual inspection.

e. **Drying.** All hose must be dried before being stored. The interior of each length must be drained of all water. Water that **remains** in the hose for any length of time tends to remove the sulfur from the rubber, as shown by a sulfuric acid solution which can be drained from carelessly stored hose. Hose-drying racks may be of any size or general **arrangement** as long as they have a reasonable slope to encourage **drainage**.

f. **Storage.** Proper storage of unused hose is a vital part of hose maintenance. To prevent rapid deterioration, hose should be stored in a clean, dry, well-ventilated location out of direct sunlight and away from heating pipes and radiators. Heat and sunlight cause rubber covers and linings to become hard and brittle.

g. **Replacing Damaged Couplings and Salvaging Hose.** Fire-department personnel are responsible for replacing damaged hose couplings and for salvaging damaged hose. Damaged hose may be salvaged by cutting out defective portions and recoupling the **remaining** portions. Not less than **two-thirds** of a section should be recoupled, although short lengths may be used occasionally for purposes other than layouts to fires. Couplings should be removed and replaced as follows :

(1) Place the coupling in a vise and cut through the expansion ring with a chisel **or** some other tool.

(2) Remove the expansion ring, hose, and rubber gasket.

(3) Cut off the damaged portion of the hose with a sharp knife and make sure that the end of the hose is square and smooth.

(4) Place the expansion ring in the coupling.

(5) Fit the expansion ring inside the hose flush with the hose end.

(6) Insert the hose in the coupling tailpiece.

(7) Make sure the hose is flush with the gasket and the shoulder of the coupling.

(8) Using an expansion tool, expand the ring **until** it locks firmly inside the coupling. Several types of expansion tools are manufactured. The directions for use and specifications for pressure are published by each manufacturer. Follow these directions and specifications exactly.

h. **Hose Records.** Complete **records** of performance, maintenance, and testing are a basic part of any maintenance program. The minimum records required for **firehose** are kept by fire-department administrative personnel.

(1) As each length of hose is received, an identifying number is stamped on its coupling. At the same time, a record (DA Form **5-78**) is set up indicating the hose number, type of hose, date received, and manufacturer (fig. 2-19). Thereafter, operating and maintenance data are entered regularly on this form.

(2) Entries include the date the hose was tested, test pressures, and remarks on the test; explanation of any hose failure, the cause and the date ; date of any recoupling; and details of other unusual maintenance. **Firehose** records are kept in the fire station where they are available for immediate reference. In addition, copies of test reports **may** be kept in the daily department **records**.

## 2-8. Hose Couplings

a. **Use.** Hoses are issued in sections fitted with a **female-threaded** coupling at one end **and** a **male-threaded** coupling at the other. Hard-suction hoses are usually in 10 to **14-foot** (3 to **3.8-meter**) lengths. Hose lines may be made any desired length by coupling individual sections together. For fire service use, hose couplings must-

(1) Be easily and quickly made up and broken (connected and disconnected).

(2) Form a watertight connection when handtight.

(3) **Hold** securely when hose is dragged or hoisted.

(4) **Withstand** damage **from** dragging and dropping **when coupled**.

(5) Be reusable so that damaged portions of hose, if close enough to an end, can be cut off and the remaining portion recoupled.

b. **Types.** Several types are available, the screw type having a male coupling with external threads and a swiveling female coupling with internal threads being most widely used. Couplings should **conform** to the National Standard Fire Hose Thread (**NST**) for the particular size **hose**. This enables hose to be used interchangeably when different departments work together on the fire ground. The following are some of the couplings and connections.

(1) **Double male couplings** or connections

6440 HOSE NUMBER		2½" SIZE		Double Jacket TYPE		50' LENGTH		Lewis Products MANUFACTURER	
2-69 DATE MANUFACTURED		Polyester Fiber GRADE		10-69 DATE RECEIVED		400 GUARANTEED PRESSURE		AIBB NAME OF INSTALLATION	
DATE IN SERVICE	LOCATION OR COMPANY NO.	TESTED		DATE OUT OF SERVICE	TYPE COUPLING	REMARKS (OK or failure of test, reason out of svc. etc.)			
		DATE	PRES-SURE						
12 Oct '69	Co. 3	9 Oct '69	250		Brass Packer Lug	O.K. (Test)			
4 Nov '69	Co. 3			4 Nov '69		Coupling, Male - out of round.			
10 Nov '69	Co. 3	10 Nov '69	250			Repair & Test.			
6 Aug '70	Co. 3			6 Aug '70		Ruptured.			
10 Aug '70						Salvaged.			

DA FORM 1 JUN 56 5-78

FIRE HOSE RECORD  
(TM 5-687)

Figure 2-9. Sample firehose record.

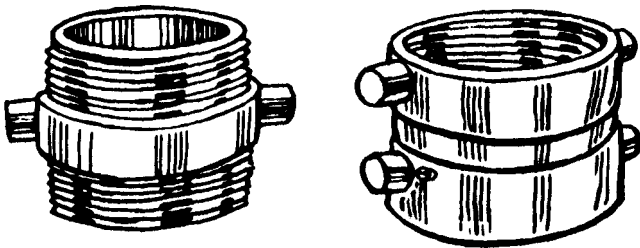

Figure 2-10. Double male and double female couplings.

consist of a single piece of metal hose coupling containing two sets of exposed male threads (fig. 2-10). The purpose of the double male connection is to enable the joining of two female connections which could not otherwise be united.

(2) Double female couplings consist of two or three pieces of metal hose coupling containing two sets of female threads (fig. 2-10). When double female couplings have only one swivel, the connection frequently contains only two pieces of metal, and the solid portion should be connected first. Double female couplings which have two swivels consist of three metal parts, and it is optional as to which female should be connected first. The purpose of the double female connection is to

connect two male couplings to complete a hose layout.

(3) Other types of coupling include *snap*, *quarter turn*, and *reducing couplings* (fig. 2-11). The snap coupling has spring loaded clips or lugs on the female coupling which clamp over a ring on the male coupling. Couplings are broken by disengaging the clips. The quarter turn coupling has beveled lugs on the couplings at each end of the hose. They are made up by twisting a quarter turn, which causes the beveled lugs to interlock. While both types can be made up and broken quickly, the advantage of being able to couple with a neighboring fire department's hose may be lost. Reducing or five part couplings are often used on 3-inch (7.6-centimeter) hose so it can be used interchangeably with 2½-inch (6.35-centimeter) hose. The smaller waterway caused by the reduction does not affect performance much because the length of small waterway is very short and a jet or venturi effect is created. Except for the reducing feature and construction, they are the same as the NST screw type.

c. Features of Screw Type Couplings. The NST standards specify the number of threads per inch

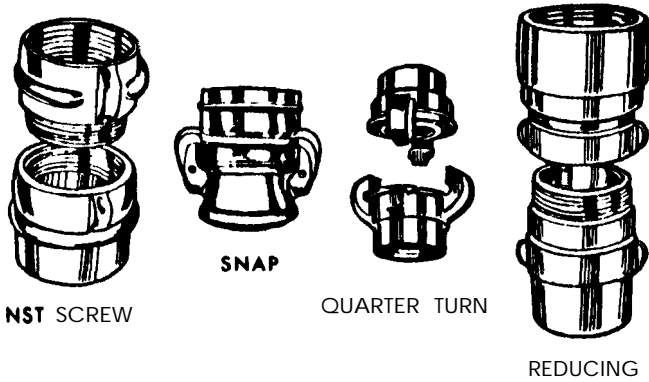

Figure 2-11. Couplings.

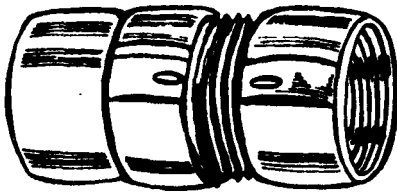

Figure 2-12. Higbee thread indicator.

(or centimeters), the shape and dimensions of threads, and use of the *Higbee cut*. The latter consists of cutting a blunt end on the first thread so that a positive start is made in engaging threads and prevent the crossing of threads. It also results in a short blank end on each coupling that helps to **align** the threads and reduces chances of damaging threads if the coupling is dropped. The *Higbee thread indicator* (fig. 2-12) is a notch cut in one lug to show the position of the Higbee cut. By lining up the thread indicators on both couplings, and they are deep enough to be felt with gloves on, threads will engage on the first turn.

**d. Material.** Brass alloys are commonly used for couplings. They are also made of aluminum alloys, aluminum, and malleable iron. Iron rusts and pure aluminum, while light, is easily damaged. Various aluminum alloys are lighter than brass and hold up well in service, but are more expensive.

**e. Lugs.** Lugs (fig. 2-13) are provided on couplings so that a grip can be obtained with wrenches, called spanner wrenches or *spanners*, (fig. 2-14) to assist in breaking couplings. On rubber lined fabric hose the *rocker lug* (either two or three lugs) is normally used. This consists of rounded ears which provide a good gripping surface for wrenches, but tend to slide over obstructions as hose is laid. Couplings with *pinlugs*,

*dot* or Navy type lugs, and *nut* or forestry type shape are also used. Pin type lugs catch on obstructions and on each other in the hose bed. Slot and nut type couplings are satisfactory but the rocker lug is better suited for use with different types of spanners and provides a better grip when making handtight connections. Making and breaking couplings is normally unnecessary when using booster hose; therefore, couplings with holes for use with special booster hose spanners are usually used. These have no projections to catch on objects. Hard and soft sleeves, on the other hand, are carried, rather than dragged, and must be made up each time the sleeve is used. They are usually equipped with long handled lugs to facilitate making and breaking of the couplings.

**f. Means of Attaching to Hose.** The most common means of attaching couplings to hose

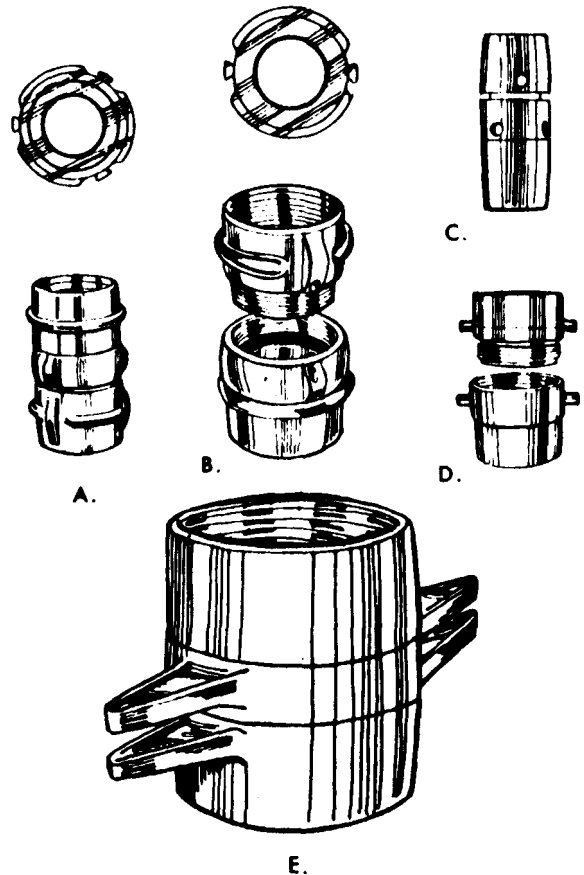

A. THREE ROCKER LUG    B. TWO ROCKER LUG  
 C. BOOSTER TYPE WITH HOLES INSTEAD OF LUGS  
 D. PIN LUG    E. LONG HANDLED TYPE FOR USE WITH SLEEVES

Figure 2-13. Types of coupling lugs.

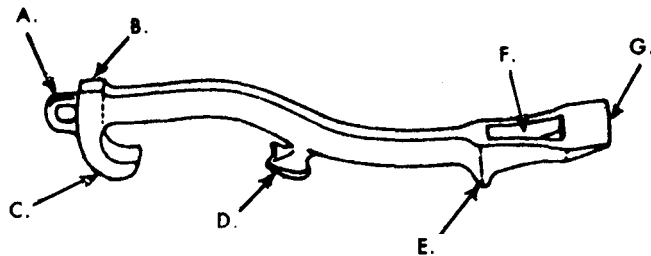

- A. BELT HOOK EYELET
- B. HAMMER HEAD
- C. SPANNER CENTER LUG CLAW
- D. UNCOUPLING CENTER LUG CLAW
- E. PRY HEEL OR FULCRUM
- F. GAS COCK SLOT
- G. WINDOW JIMMY

Figure 2-14. The spanner wrench.

(fig. 2-15) is with an *expansion ring*. A ductile brass ring or collar is placed inside the hose. The coupling is placed over the hose and the ring expanded under great pressure to force the hose jacket against the corrugated inner face of the coupling. Couplings can be reused by extracting the expansion ring and using a new one. A means of attaching couplings with a screw sleeve is also used. With this method, the coupling shell slips over the hose jacket. A sleeve containing the male threads or female swivel and threads on one end, and a double threaded section on the other end, is screwed into the hose and forced against the shell. Such couplings withstand greater water pressure and pull on the hose than expansion ring types. They are used most often with booster hose, though available for hose up to 2½-inch (6.35-centimeter) diameter. A special key and wrench are used to attach the couplings, which can be removed for reuse by unscrewing the sleeve. A third means involves slipping a coupling shell, with threads or swivel and threads, over the hose jacket, inserting a tapered sleeve and pulling up on the shell. To reuse, the shell is driven back off the tapered sleeve.

*g. Making up Couplings.* Couplings, particularly on rubber lined fabric hose, must be made up quickly. Making up or connecting couplings involves two actions: alining the hose and couplings and connecting the threads. If hose is being loaded in a hose bed, the additional step of checking for the presence of a gasket in the female coupling bowl is taken before making up the coupling. The hose is alined so that the flat sides of each length are in approximately the same plane.

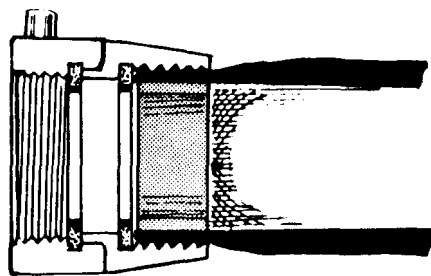

COUPLING ATTACHED TO HOSE WITH EXPANSION RING.

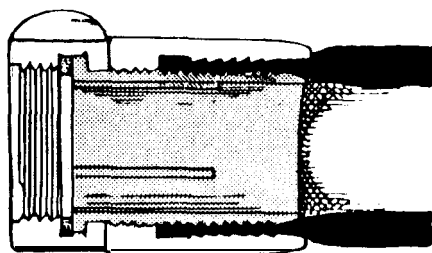

COUPLING ATTACHED TO HOSE WITH SCREW SLEEVE.

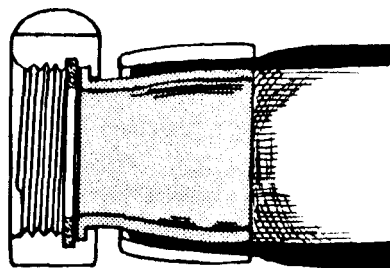

COUPLING ATTACHED TO HOSE WITH TAPERED SLEEVE.

Figure 2-15. Attaching couplings to hose.

Next, the couplings are alined so that threads will engage. Then the couplings are held steady and the threads engaged by operating the swivel on the female coupling.

(1) *One-man coupling procedure.* Making up couplings is normally a one man operation (fig. 2-16). The female coupling is picked up with one hand on the swivel. The hose is brought across the right (or left) hip with the feet spread comfortably apart. The hose is held against the hip with the forearm. The male coupling is held with one hand, the female coupling with the other. The couplings are alined by manipulating the swivel on the female coupling to engage the threads. An alternate method is to aline the hose and couplings on the ground. The firefighter faces the couplings, feet spread comfortably, with one foot on the hose directly behind the male coupling (fig. 2-16). This will tilt up the coupling and at the

same time hold it in position. The hose with the female coupling is brought up to the male coupling and the threads are engaged by operating the swivel. This method is not practical in deep snow, mud, or similar conditions. The swivel is rotated counterclockwise until a click is heard, then the threads are engaged by rotating the swivel in the opposite direction. If the couplings contain Higbee thread indicators, line up the notched lugs and rotate in a clockwise direction.

(2) **Two-man coupling procedure.** Two men make up couplings (fig. 2-17) by each grasping a coupling and holding the hose against the hip with one forearm. The man with the male coupling holds the coupling so that the other man can align the female coupling with one hand and oper-

ate the swivel with the other, thus engaging the threads. Couplings are made **only** handtight because the hose is constructed so that when it is charged with water it twists and tightens the couplings. If couplings are tightened with wrenches the gaskets may be flattened until they protrude into the waterway which partially restricts the flow of the water. It also damages the gasket. The last step in making up couplings is to give a sharp twist or snap as the threads seat home. With a good gasket this results in a watertight connection. Gaskets are checked by removing them from the female swivel and flexing them between the thumb and forefinger (fig. 2-18). If they spring back to a flat position they are usable. If not they should be replaced. **Do not leave couplings without a gasket.** If the gasket must be replaced, do so as soon as possible. If the female swivel on a hose coupling continues to swivel after the couplings are tightened, the threads have not seated completely and require further adjustment.

**h. Breaking Couplings.** Couplings usually are



MAKING UP COUPLINGS.

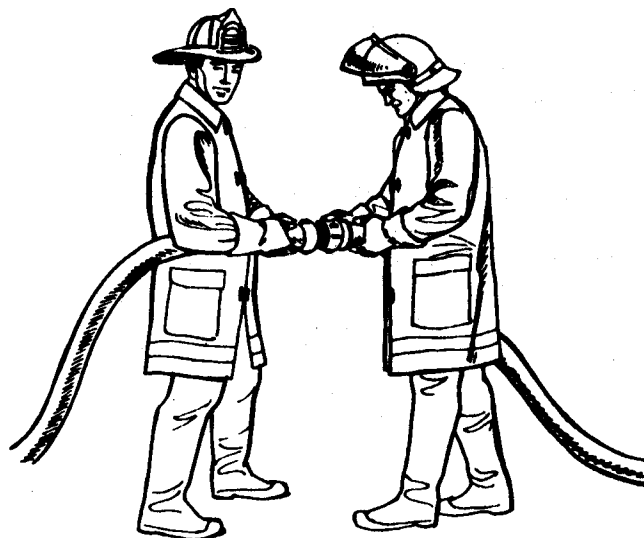
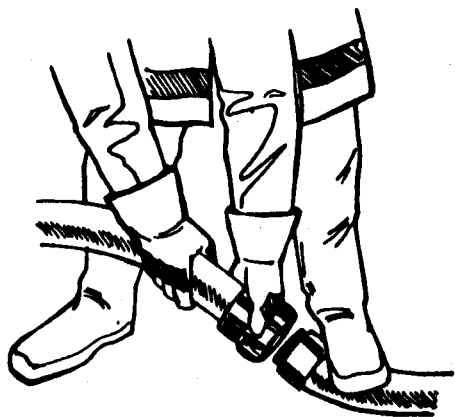

Figure 2-17. Two men making up couplings.



ALTERNATE METHOD OF MAKING UP COUPLINGS.

Figure 2-16. Coupling hoses.



Figure 2-18. Checking the condition of a gasket.

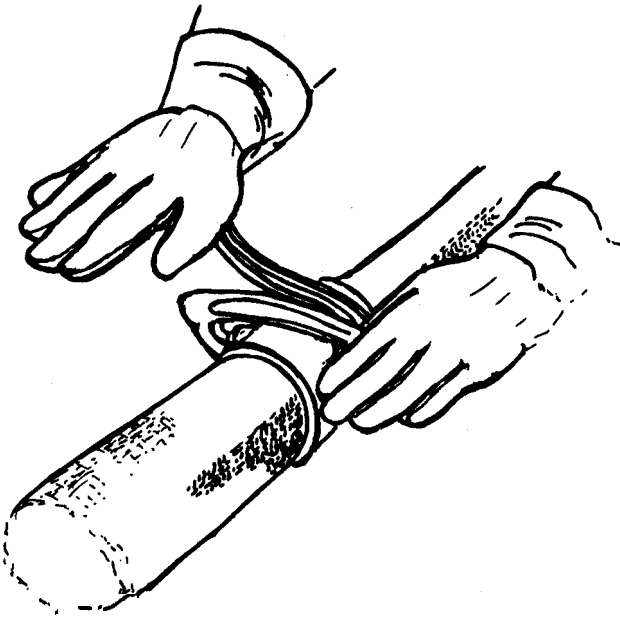

Figure 2-19. Using spanners to break couplings.

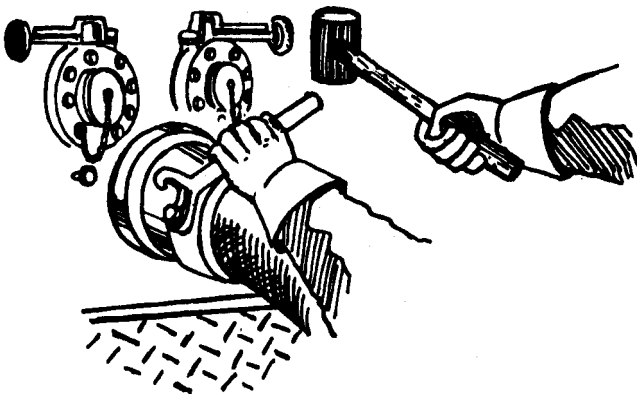

Figure 2-20. Using a rubber mallet to tighten couplings for drafting

broken (released) in the same way they were made-by hand, In the process, the arm and shoulder muscles are used, not the fingers. Spanner wrenches (fig, 2-14) are used as shown in figure 2-19 on couplings that cannot be broken by hand. The fingers are extended as shown in figure 2-19 to prevent injury when the coupling breaks loose or the spanner slips.

*i. Coupling Sleeves for Drafting.* Hand-tightened connections usually suffice for coupling hose, but connecting sleeves for drafting and booster hose require tightening with a tool, In drafting operations, hard sleeves must be airtight. This is done by using a wooden or rubber mallet as shown on figure 2-20.

*j. Avoiding Damage to Couplings.* Damage to couplings is usually the result of the following:

- (1) Dropping of uncoupled couplings.
- (2) Dragging of uncoupled couplings.
- (3) Excessive strain or pull, or pressure, on a hose line.
- (4) Grit or dirt in the swivel This binds the swivel on female couplings. Dirty couplings must be washed with water that is mildly detergent. Oil or grease only increases the possibility of picking up more dirt.
- (6) Crossing of couplings by heavy vehicles.

### 2-9. Nozzles

Nozzles are devices which regulate the amount velocity, and form of water released from a hose. The following are the different types of nozzles used by firefighters.

*a. Fog Node.* A fog or spray nozzle (fig. 2-21) normally consists of a fog tip, a controlling shut-off, and, in the larger sizes, a playpipe with handles to make controlling of the nozzle easier, The fog or spray nozzle breaks up the water stream into particles of water which cover a larger area and increase the heat absorbing capability of the

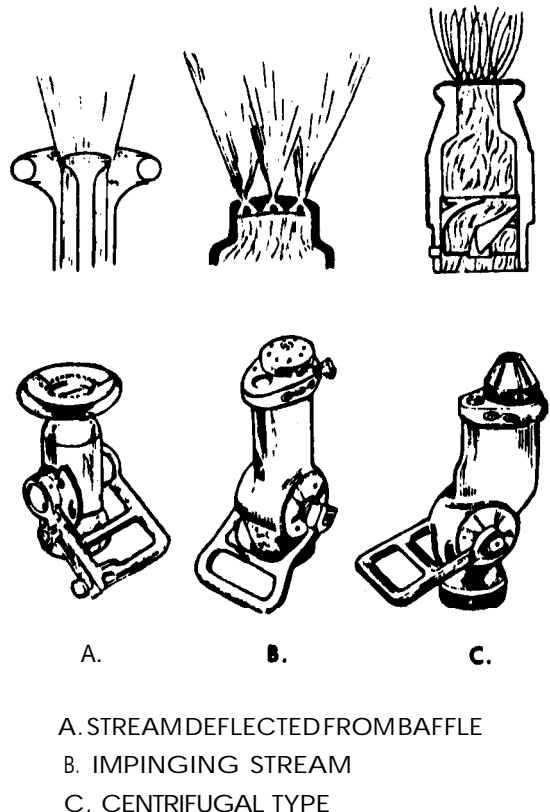

A. STREAMDEFLECTEDFROMBAFFLE  
 B. IMPINGING STREAM  
 C. CENTRIFUGAL TYPE

Figure 2-21. Types of high velocity fog

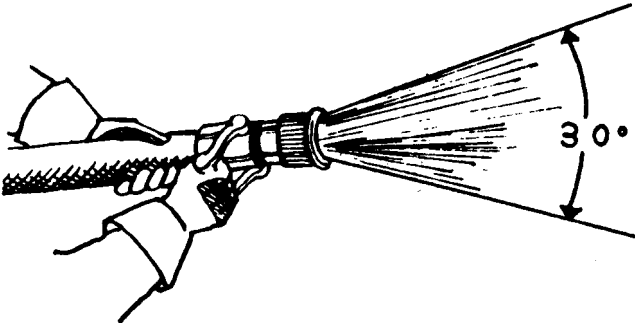

Figure 2-22. Measuring the angle of a fog stream.

water. Fog nozzles may produce a fixed fog pattern, or the pattern may be adjustable from a straight stream (which is not a solid stream) to a wide angle fog of nearly 180 degrees. The angle of a fog stream is the approximate angle formed from one edge of the stream to the other (fig. 2-22). Nozzles are available that discharge an almost constant volume of water as fog patterns are changed. Others will discharge varying volumes of water depending on the pattern. Still others have selectors to change the volume of discharge, with the discharge remaining almost constant as patterns change at a given setting.

**b. Solid Stream Nozzle.** The solid stream nozzle (fig. 2-23) normally consists of an open tip, a controlling shutoff, and a playpipe with handles to make controlling the nozzle easier. The volume of water discharged at a given pressure depends on the size of the tip. Tips are usually interchangeable to obtain different volume discharges. This is an aid if the water supply will not provide an effective stream with the larger size tips. The purpose of a solid stream nozzle is to project water so that it will travel a distance or will penetrate through loose or porous material. Effectiveness of the nozzle depends on a smooth surface in the tip, so care must be taken not to drop or otherwise dent or damage the tip. Design of the solid stream nozzle produces a thrust backward on the nozzle and hose when it is used. It is important to be prepared for this reaction when using this type of nozzle.

**c. Combination Nozzle.** The combination nozzle (fig. 2-24) has both a fog tip and a solid stream tip. The controlling shutoff has positions for both fog stream and solid stream operation, as well as an off position. It should not be used on electrical or flammable liquids fire because the control handle might accidentally be shifted to the solid stream position.

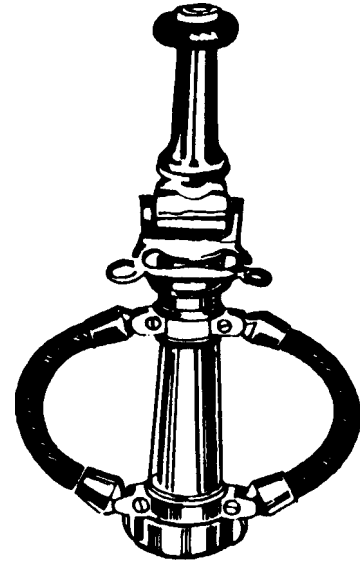

Figure 2-23. Solid stream nozzle.

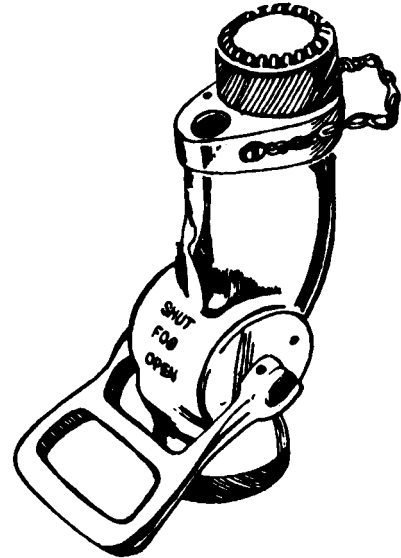

Figure 2-24. Combination nozzle.

**d. Applicators.** An applicator (fig. 2-25) consists of a controlling shutoff, a pipe 2 to 10 feet (0.6 to 3 meters) long, often bent at a 45 or 90 degree angle at the tip end, and a tip which may be of the solid stream, high velocity fog, or low velocity fog type.

(1) **Low velocity fog tip.** This is an impinging stream nozzle or head (fig. 2-25) in which the streams join (impinge) outside the head, producing a cloud of fog in the vicinity of the tip, as compared to a fog stream which projects out from the tip.

(2) **Puncture nozzle.** This is a pointed, hardened steel nozzle (fig. 2-26). This nozzle can be



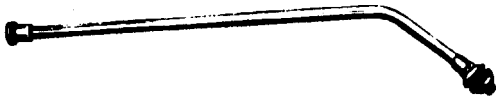

LOW VELOCITY FOG APPLICATOR.

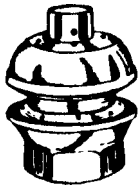
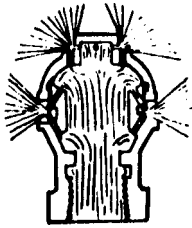

LOW VELOCITY FOG TIP.

Figure 2-25. Low velocity fog tip and applicator.

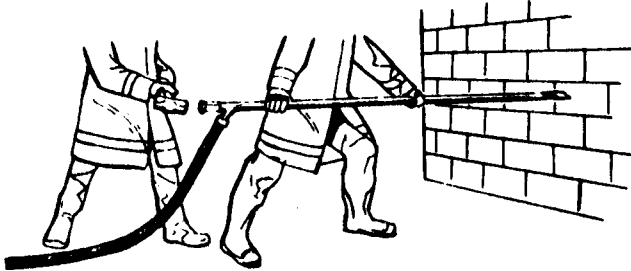

Figure 2-26. Puncture nozzle.

driven through walls and siding, or into loose material such as baled fibers. A place is provided near the base of some puncture nozzles so they can be driven in with a flathead axe or similar tool.

(3) **Partition nozzle.** The partition nozzle (fig. 2-27) discharges a solid stream at a 90° angle to the pipe, with the direction of the stream controlled by a handle. The partition nozzle often has a pointed projection near the tip to aid in pushing it into a wall, though materials through which it can be driven are more limited than with the puncture nozzle.

**e. Distributor and Cellar Pipe.**

(1) **Distributor.** A distributor (fig. 2-28)

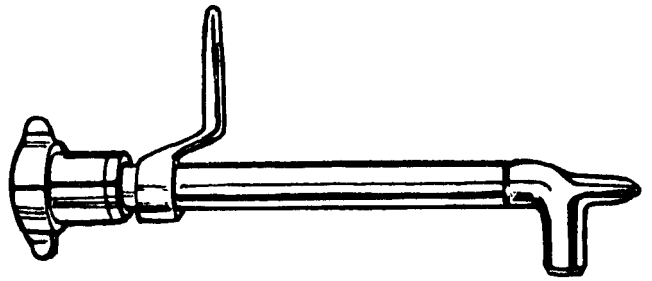
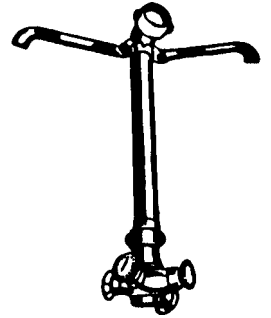
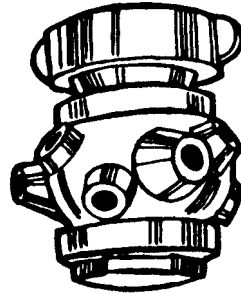

Figure 2-27. Partition nozzle.



ROTATING DISTRIBUTORS

ROTATING DISTRIBUTOR IN OPERATION

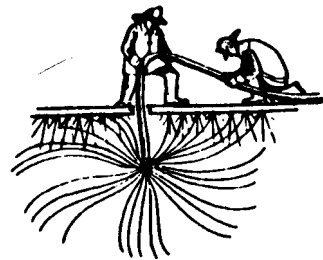
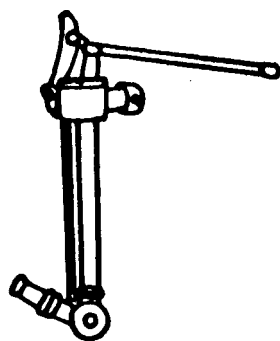

Figure 2-28. Distributors.

consists of a swivel with an arrangement of straight or fog tips. The reaction of the tips causes the swivelled head to rotate rapidly. This throws a spray in a spherical pattern around the distributor. It is useful for attacking fires that cannot be reached by other means. Before the device is put in operation a controlling shutoff must be placed in the line so that the distributor can be shut down before removing it.

(2) **Cellar pipe.** The cellar pipe (fig. 2-29) consists of a short pipe with one or two straight tips and levers to control the direction of the stream or streams. Cellar pipes are used in the



CELLAR PIPE



CELLAR PIPE IN OPERATION

Figure 2-29. Cellar pipe.

same manner as distributors but have greater reach. They also require a controlling shutoff like the distributors.

**f. Master Stream Devices.** Basically, a master stream device (fig. 2-30) consists of a siamese or manifold arrangement for collecting water from more than one line of hose and for mechanically directing the stream and the nozzle tip. Tips are removable so that the proper type and size can be used for a particular situation. A length of pipe called a **stream straightener** is used with solid stream tips. It contains thin baffles or vanes to keep the large volume of water from swirling and breaking up the stream. A **monitor nozzle** is used from the ground and can be mounted for use on an engine. A **deluge set** is an older version of the monitor nozzle. It consists of separate parts joined by a large diameter pipe or hose. It normally is not mounted on an engine because its rotation would be limited. The **deck pipe** is mounted on an engine, connected directly to the pump by piping. It may also be connected to siamese inlets mounted permanently on the engine or truck. A **ladder pipe** is attached to an aerial lad-

der, It is supplies by a large diameter hose with the Siamese on the ground. Some ladder pipes are mounted permanently on the bed section of an aerial ladder. All master stream devices have controls to govern the vertical direction of the stream. The monitor nozzle and deck pipe have horizontal direction controls as well. Some ladder pipes and deluge sets have controls to permit limited horizontal movement of the stream. A ladder pipe should be moved horizontally by rotating the ladder. This avoids placing dangerous stress on the ladder.

**g. Sprinkler Heads.** Heads on sprinkler systems (fig. 2-31) in structures act as metering devices. They give the advantage of applying water in the fire area without sending men into it. Fire departments must supply such systems with hose lines from engines to assure adequate volume and pressure of water.

**2-10. Devices Which Control Flow**

The following are in-line valves which control the flow of water through hose lines:

**a. Ball Valves.** The ball valve (fig. 2-32) consists of a housing with couplings, a ball with a waterway through the middle, and a handle to

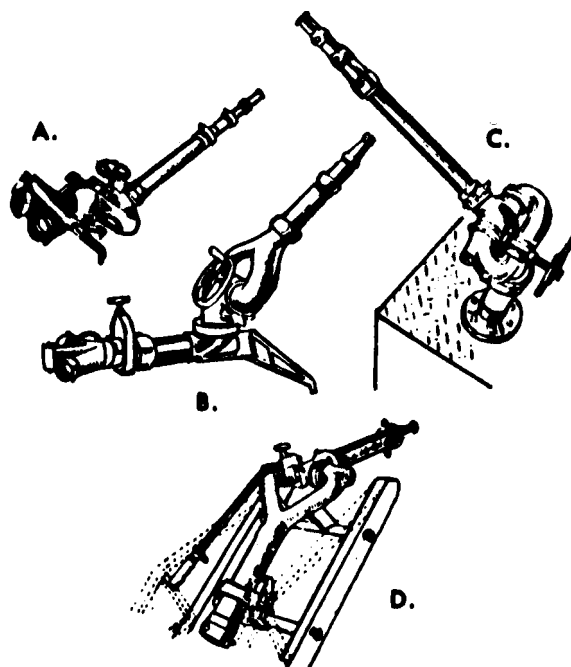

A. MONITOR NOZZLE      B. DELUGE SET  
C. DECK PIPE              D. LADDER PIPE

Figure 2-30. Master stream devices.

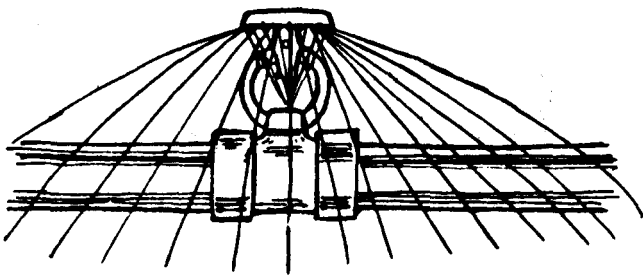

Figure 2-31. Sprinkler head discharging.

as the ball valve, except that the flat **baffle in-**stand of a ball with a waterway forms the shutoff. The chief advantage of the butterfly valve is ease of maintenance and repair.

*d. Rotating Baffle Valve.* Rotating baffle valve (fig. 2-32) consist of two baffles, each with two open 90-degree segments. Turning one of the baffles to line up its open segments with those in the second opens the valve. Turning it to line up its open segments with the closed segments in the second baffle closes it. This type valve is also known as the "gizmo".

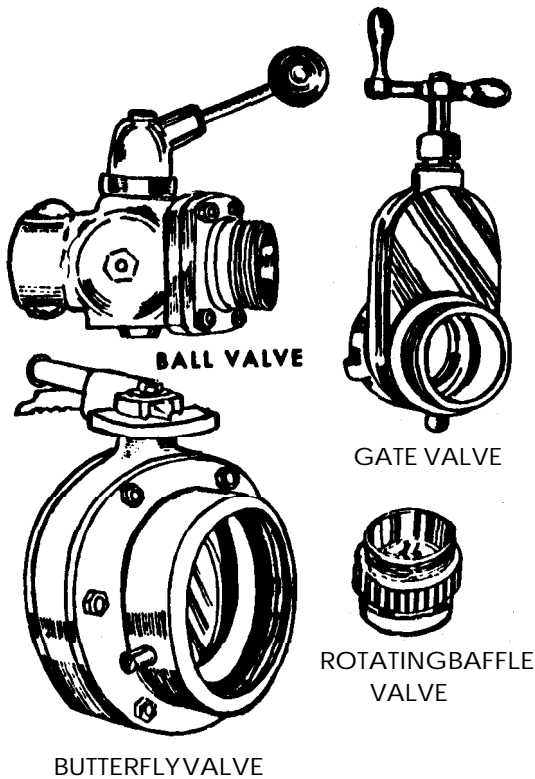

Figure 2-32. Devices that control flow.

2-11. Devices That Combine or Divide Flow  
The following are combining or dividing devices used by firefighters :

*a. Wyes.* A wye (fig. 2-33) divides a hose line into two lines of the same or smaller size. If it has controlling valves (gate or ball valve), it is known as a *gated wye*. Most controlling valve wyes today are manufactured with ball type valves. If the wye divides the line into smaller lines it is called a *reducing wye* or *gated reducing wye*. The gated reducing wye which divides a 2½-inch (6.35-centimeter) hose line into two 1½-inch (3.8-centimeter) lines is very common.

turn the ball. In most models, when the handle is turned in line with the hose line the valve is open. Turning the handle to a right angle to the hose line, or to a right angle to the open position, rotates the ball and shuts the valve. Earlier versions have a cylinder in place of the ball.

*b. Gate Valve.* The gate valve (4ig. 2-32) has a housing with couplings and a baffle, or solid plate which is operated by a handle and screw arrangement. Turning the handle *moves* the baffle down into (or up out of) the waterway.

*c. Butterfly Valve.* A butterfly valve (fig. 2-32) or keystone type valve consists of a housing with couplings, and a baffle or plate connected to a quarter turn handle. It operates in the same way

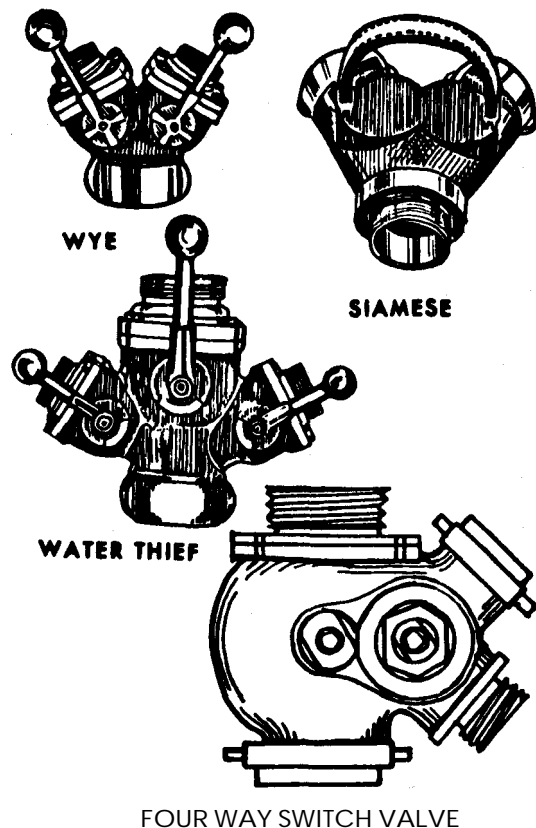

Figure 2-33. Combining and dividing devices.

**b. Siamese.** The **siamese** is a Y-shaped connection (fig. 2-33) which combines two or more hose lines into a single line of the same or larger size. It is used primarily to join two  $2\frac{1}{2}$ -inch (6.35-centimeter) intake lines into a single  $2\frac{1}{2}$ -inch (6.35-centimeter) outlet line or into other heavy stream appliances. Siamese may have swing check valves (clapper valves) to assure that water will not flow back through any of the inlets, and are then called *clapper valved siamese*. They may have gate or ball valves called *gated siamese*. A **siamese** that combines from two to four small lines into a single larger line is known as an *increasing siamese*. The gated increasing **siamese** is often carried on the large steamer inlet of a pumping engine and is also known as a **suction siamese**.

**c. Water Thief.** The **water thief** (fig. 2-33) has a  $2\frac{1}{2}$ -inch (6.35-centimeter) inlet and two gated  $1\frac{1}{2}$ -inch (3.8-centimeter) discharges, as well as a  $2\frac{1}{2}$ -inch (6.35-centimeter) discharge which may or may not have a controlling valve. It is used for taking short attack lines from a  $2\frac{1}{2}$ -inch (6.35-centimeter) or B-inch (6.6-centimeter) supply line.

**d. Four-Way Switch Valve.** The four-way switch valve (fig. 2-33) is used to hook up a supply line to a hydrant. It permits hooking up a pumping engine to the hydrant later, without shutting down the supply, and then increasing water pressure in the supply line. This is done by moving a single rotor or two baffles, depending on the design of the valve, so the path of the water is changed from the supply line to the engine and back through the supply line.

## 2-12. Adapters for Coupling

Adapters are used for coupling hose which cannot be joined because of a difference in coupling size, threads, or the fact that both are male or female.

**a. Adapter.** True adapters permit joining couplings with **unlike** threads. The rigid adapters consist of a short tube with one type of thread on the female end and the other type on the male end. The adjustable adapter (fig. 2-34), such as the universal and **automatic** types, normally have a male coupling thread which matches the department's standard thread on one side and teeth on the other side. The teeth adjust over the male hose coupling, either by spring action or manual lever operation, engaging the male threads. A twist of the hose coupling tightens the connection.

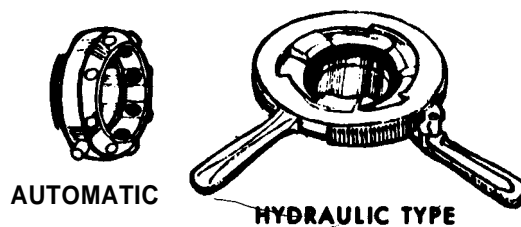

Figure 2-34. Adjustable adapters.

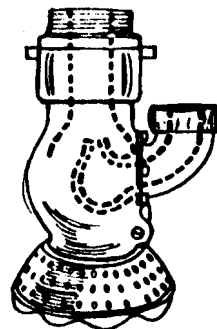

Figure 2-35. An eductor.

**b. Reducers and Increases.** Reducers and increasers are used to join different size hose couplings. The reducer is a rigid adapter with a large female thread on one end and a smaller size male thread on the other. The increaser is a rigid adapter with a small female and larger male thread. Double female reducers equipped with a swivel on the smaller end are used with sleeves.

## 2-13. Eductors

An eductor (fig. 2-35) is a device that introduces liquid or powder into a water stream by a jet or venturi effect. The waterway coming into the **eductor** reduces in size to form a nozzle which is directed into a larger opening on the discharge side. The action of this jet creates a siphon effect which is used to pick up foam liquid, chemical foam powder, or other chemicals to be added to the stream. Specially designed siphon **eductors** are **also** used to pick up water when a pump cannot or **should** not be used to draft the water directly.

## 2-14. Tools

The following are the major tools used to aid in working with hose and appliances:

**a. Tools for Working with Hose and Appliances.** Tools which aid in working with hose and appliances include spanner wrenches, hydrant wrenches, and drafting sleeve mallets. **Spanner wrenches** (fig. 2-14) are used to break couplings,

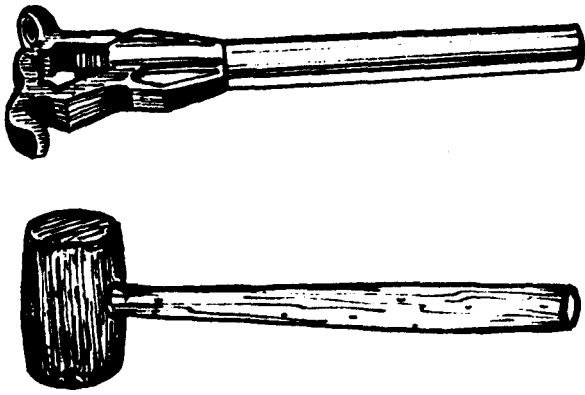

Figure 2-36. Hydrant wrench and rubber mallet.

which, with the exception of drafting sleeves, are made up handtight. **Hydrant wrenches (fig. 2-36)** consist of long handled box wrenches. Some types have an adjustable box to permit its use on hydrant operating nuts of different size. Some have ears to permit use as a spanner. The hydrant wrench is used to remove hydrant caps and to operate the hydrant operating nut which controls the flow of water from the hydrant. It is also used to operate the valves on some models of four-way switch valves. The adjustable pipe wrench is not normally used to turn a hydrant operating nut because it will **damage** the nut. It is used, however, if a hydrant with a damaged or missing **nut** must be used at a fire, as the hydrant must be repaired anyway. **Drafting sleeve mallets (fig. 2-36)** have a hard rubber or wooden head. They are used to tap the couplings on drafting sleeves to secure an air tight seal. Mallets must be used with restraint to avoid damaging couplings.

#### b. Tools For Moving or Securing Hose Lines.

Tools which aid moving or securing hose lines include hose straps and rope hose tools, the hose holder (fig. 2-37), and the hose hoist or roller (fig. 2-38). The **hose holder** is a device which clamps around the **hose** line, or has the line threaded through it, behind the nozzle. It enables one man to control a hose line discharging a large volume of water by directing the back thrust or nozzle reaction against the ground. The **hose hoist** or roller is used as a bearing for hoisting hose or tools to a roof or upper floor.

**c. Tools For Protecting or Repairing Hose and Couplings.** Tools to protect or provide emergency repairs for hose and couplings include hose jackets, hose ramps, and chafing blocks. The **hose jacket (fig. 2-39)**, not to be confused with the fabric jacket of hose, is a metal device consisting

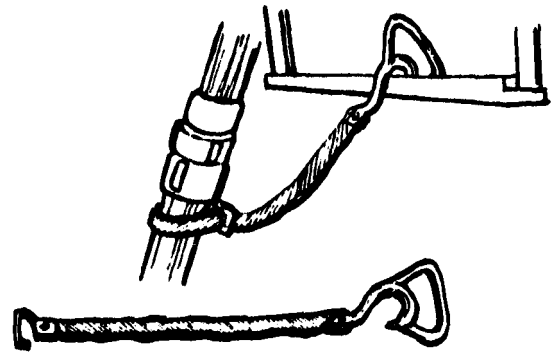

STRAP

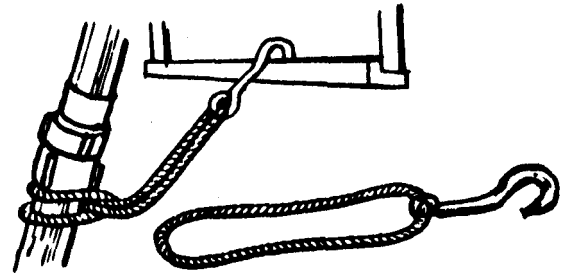

ROPE

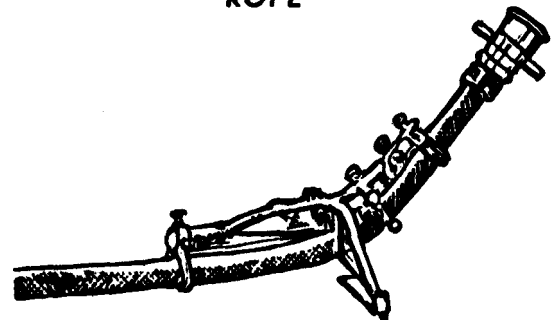

HOLDER

Figure 2-37. Hose securing tool.

of two half cylinders hinged on one edge, with a **latch** on the other. While it does not permanently repair faulty hose, it repairs leaks and tends to prevent additional damage to hose from the effect of water pressure on a hole or tear. The hose jacket can also be used to join lengths of hose with defective, mismatched or different couplings, by placing the couplings in the jacket.

**d. Hose Clamps.** Several kinds of hose clamps are **available**. Those in general use are the lever operated devices with latches, screw-down or gate types, and hydraulically operated types (fig.

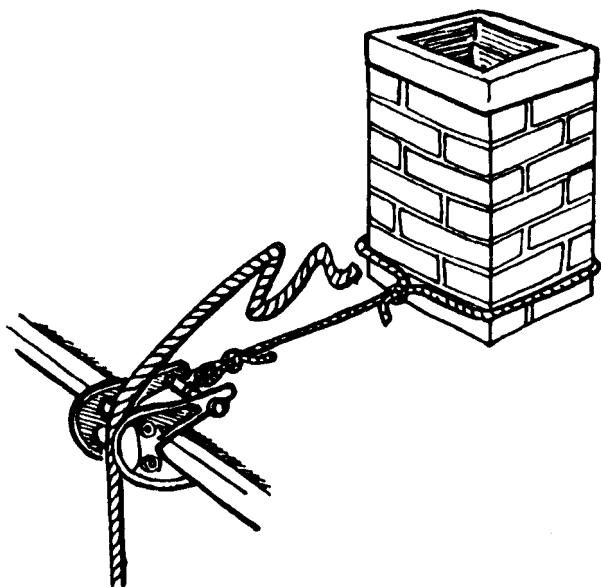

Figure 2-38. Hose hoist.

2-40). All work on the principle of using mechanical force to compress the jacket of the hose together, and stop the flow of water in a line. To operate the lever type, open the clamp, place the hose line between the jaws, and either lift up or press down on the lever. A ratchet type latch will hold the jaws in the closed position. To release, **stand clear of the lever**, hold it, down, or up, securely, and release the latch. Release the lever slowly. The lever may tend to kick out with some force when the latch is released. The screwdown or gate type is operated by placing the hose in the jaws and operating as with a gate valve. Hydraulic hose clamps are operated by placing the hose in the jaws, setting the selector to "close" with the wrench end of the operating handle, inserting the handle in the pump lug, and pumping the jaws closed. To **release** the clamp turn the selector to "open". Push the jaws to the full open position,

## 2-15. ladders

Ladders are vital during an emergency, when every second is a factor toward the success or failure of an operation. Firefighters must know the proper procedures for carrying, raising, and climbing ladders so thoroughly that they can do them almost by habit. Even after the procedures are well established in the minds of the trainees, constant practice is **essential** to maintain this degree of efficiency. Continuous training should be carried on to make these operations as nearly **automatic** as possible.

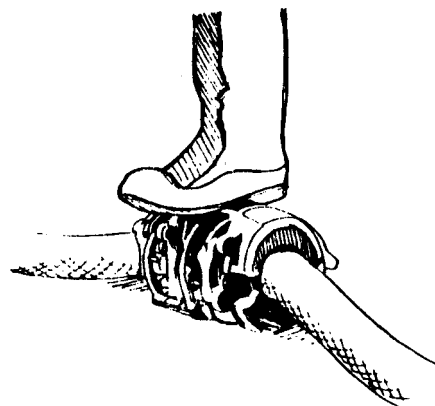
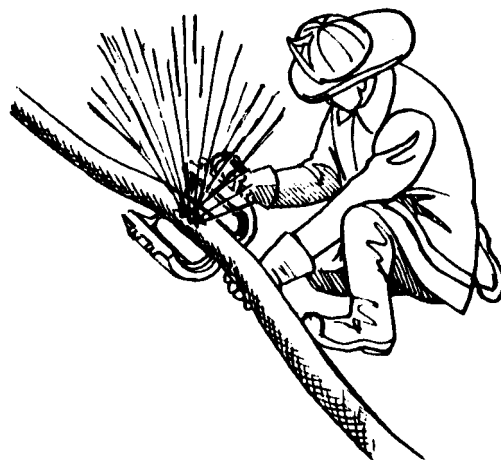

Figure 2-39. Using a hose jacket.

a. The standard ladders used by the Army consist of solid beams with cylindrical rungs set in the center of the beam. The following terms are commonly applied to ladders: **bed ladder**, the lowest section of an extension ladder; **fly ladder**, the top sections of an extension ladder; the **butt**, the ground end of the ladder; the **heel**, the extreme ground end of the ladder; the **halyard**, or **fly rope**, used for raising the fly; and the **pawl**, or **dog**, the mechanism on the lower end of the fly which locks it to the bed ladder. The heel portion of portable

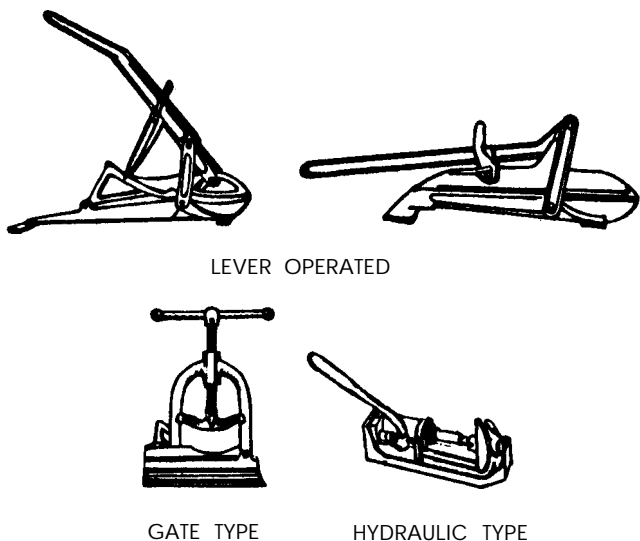

Figure 2-40. Hose clamps.

ladders should be equipped with cleats or nonskid footers.

*b.* The most common ladder in the Army fire-fighting system is the **35-foot (10.7-meter)** extension ladder. An extension ladder consists of a bed ladder and one or more fly ladders. The fly ladder, sliding through guides on the upper end of the bed ladder, contains locks which hook over the rungs of the bed ladder. This secures it in position at the desired length of the ladder. The fly is usually raised by a halyard fastened to the lower rung and operating over a pulley on the upper end of the bed. The **24-foot (7.3-meter)** extension ladder is commonly found on pumps.

*c.* Straight ladders or wall ladders contain only one section, and usually are from **12 to 16 feet (3.66 to 4.88 meters)** long. The most common size straight ladder is the **14-foot (4.27-meter)** length. The roof ladder is a wall ladder adapted for a special purpose. Roof ladders have hooks mounted on a movable socket that permits the books to fold inward when not in use. Placing the hooks over roof peaks, sills, walls, or the coping of any opening makes the ladder safe and reliable even if the butt does not rest on a foundation. The roof ladder may be used as a wall ladder when the hooks are set so they do not extend beyond the ladder beams. The roof ladder is used when the pitch or the material of the roof or bad weather endangers the men moving over it. It is valuable in climbing to the peaks of gabled roofs to remove roofing materials or to cut holes for ventilation and extinguishment. It may also be used to enter scuttle

holes or holes cut through flooring, and sidewalk openings.

*d.* On installations where there are buildings more than three stories high, special **50-foot (15.25-meter)** Bangor ladders may be necessary. These ladders may be either strategically located in the area where they are to be used, or sent to the scene of the fire, mounted on special equipment. These larger ladders require more teamwork than do the **two-man** ladders to place, raise, and lower them quickly and efficiently.

## 2-16. The Handline

Rope is indispensable in combating fires. The most widely used type of rope is the handline. Handlines are used for hoisting tools to various floors of a structure and for anchoring ladders, charged hose lines, and other accessories to stationary objects. Handlines for hoisting and anchoring should be either  $\frac{5}{8}$  or  $\frac{1}{2}$ -inch (1.6 or 2-centimeter) rope of **100-foot (30.5-meter)** lengths, with an eye spliced in one end. For quick use, a handline should be coiled in such a manner that it pays out without tangling, even when dropped from the top of a building.

*a. Coiling a Handline.* For coiling a handline, a frame containing two vertical posts about **14 inches (36 centimeters)** high and **25 inches (64 centimeters)** apart is set up (fig. 2-41). The rope is first wrapped several times horizontally around the upright posts and then wrapped around the horizontal wrappings to secure the rope around the posts. When the opposite end is reached, the horizontal pipe is pulled from the coil. The free end of the rope should be folded and slipped through the end of the coil. The free end will then be slipped through the opposite end of the coil and through the loop, thus pulling the loop tight. Loops should be made large enough for the coil to be loaded over the shoulder.

*b. Knots and Hitches.* Knots and hitches should be capable of quickly and securely serving their intended purpose and of being easily tied and untied in darkness. The rope ends should be whipped (tightly bound) to prevent fraying. Eyes may be spliced in both ends of the rope to speed up tying operations (fig. 2-42). **Damaged rope** should be replaced rather than spliced.

*c. Clove Hitch.* The clove hitch (fig. 2-43) should be used to tie a line to a **handtool** such as a pike pole. The clove hitch holds the object securely and will not slip when properly tied. It should be

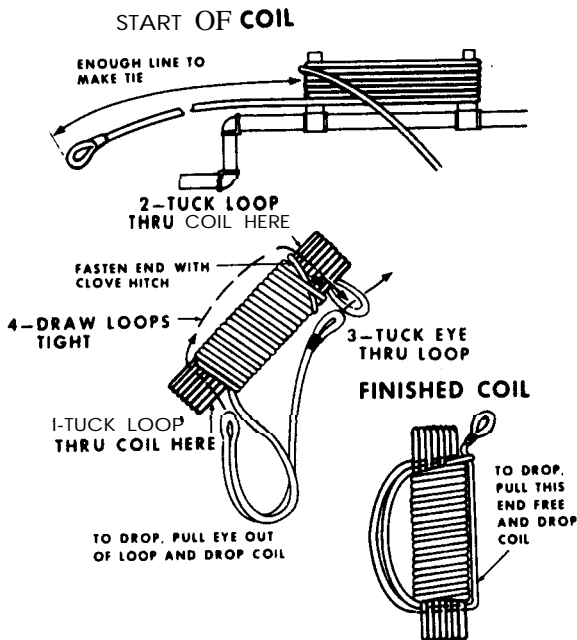

Figure 2-41. Coiling in handline.

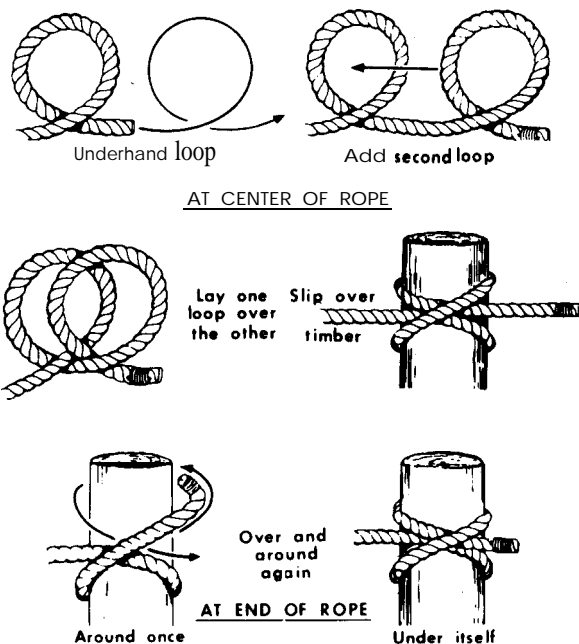

Figure 2-43. The clove hitch.

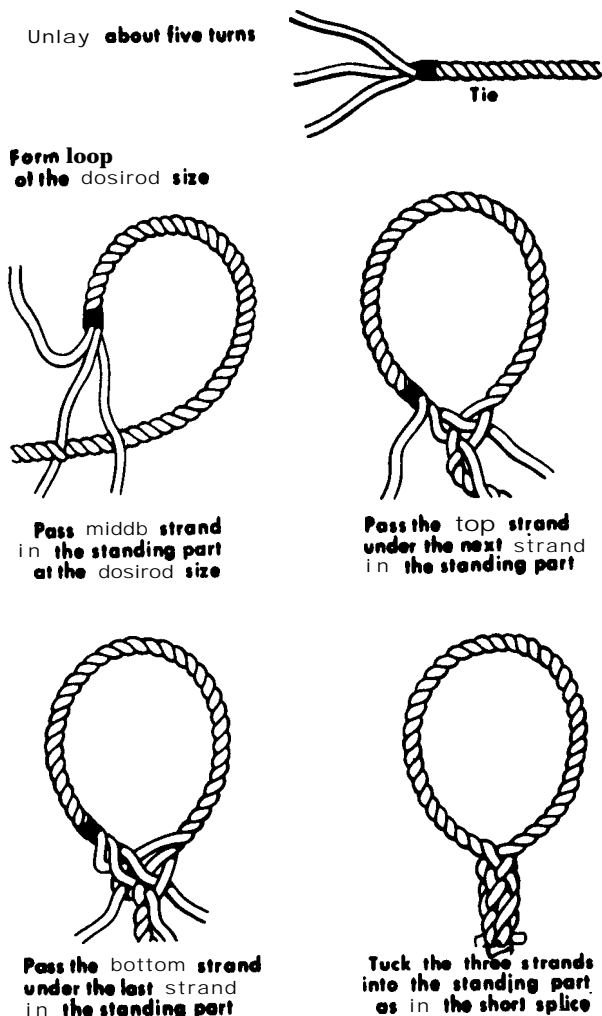

Figure 2-42. The eyesplice.

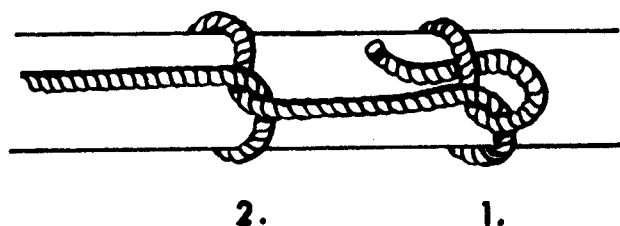

Figure 2-44. The half hitch.

tied near one end of the pole with a single half hitch around the other end.

d. *Half Hitch.* The half hitch (fig. 2-44) is a loop in a rope which is placed over or around an object so that the standing end of the rope exerts a constant strain on the loop. The running end can be secured under the loop (fig. 2-44 (1)) or may run on to another knot (fig. 2-44 (2)). The half hitch is used with other knots as a safety hitch and to give added stability to objects being hoisted.

e. *Chimney Hitch.* The chimney hitch is used when it is necessary to anchor a rope to a solid object to strengthen the position of another object, such as a charged hose or a ladder (fig. 2-45). The chimney hitch will not slip and is quickly and easily untied. This knot is used when the strain on the rope is to be constant. The rope may be shortened or lengthened by slipping the knot.



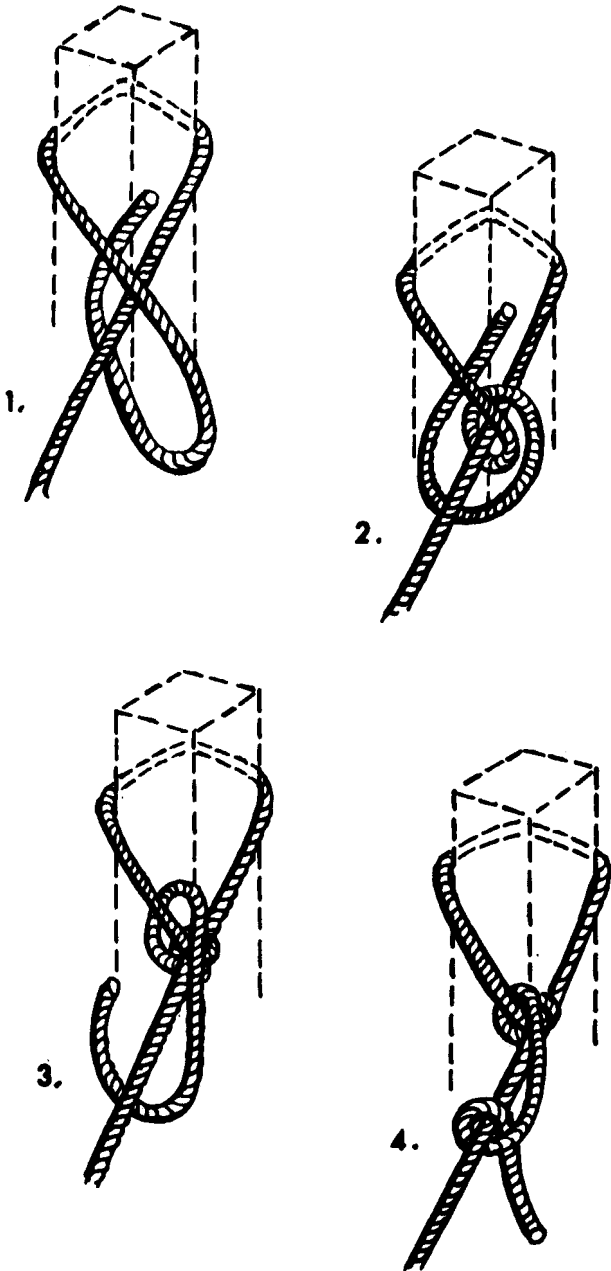

Figure 2-45. The chimney hitch.

*f. Tool Hoisting Hitch.* Tools are usually secured by at least two knots (fig. 2-46) to hold them in a relatively stable position. Long heavy tools are generally hoisted with the heavy end up. Tools with hooks or sharp 'projections, such as an ax, are hoisted in a position in which they will not catch on projecting ledges.

*g. Square Knot.* The square knot (fig. 2-47) is used to tie the ends of equal sized ropes together.

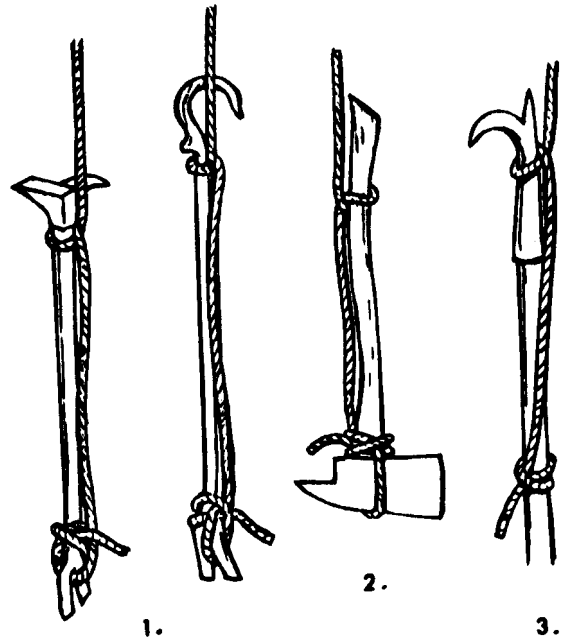

Figure 2-46. Tool hoisting hitch.

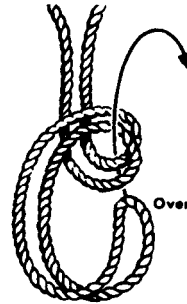
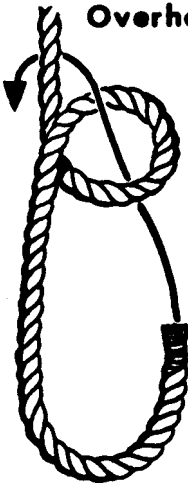

Figure 2-47. The square knot.

*h. Bowline.* The bowline (fig. 2-48) is a knot that will not slip and is easily and quickly untied. It is used to form a loop on the end of a line. The bowline on a bight (fig. 2-49) is used mainly for rescue purposes.

*i. Becket Bend.* The becket bend (fig. 2-50) is used to connect ropes of unequal 'diameter.

Overhand loop



Double rope

Overhand loop

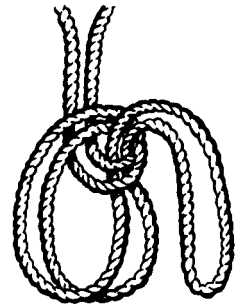

Bight end up through and down

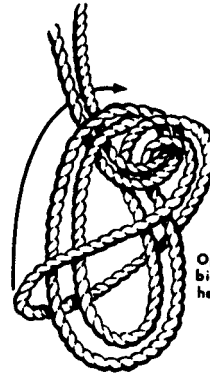

Open bight here

Bring bight up and around entire knot



Pull

Figure 2-49. The bowline on a bight.

Up through and around back

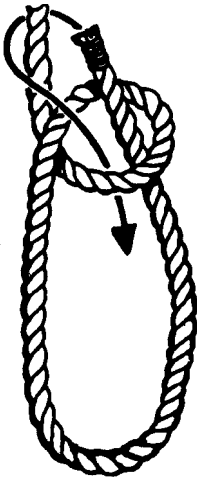

Back down through loop



Figure 2-48. The bowline.

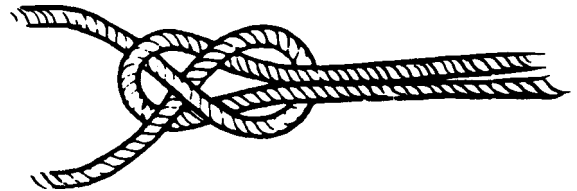

Figure 2-50. The bucket bend.

## Section IV. FIRE EXTINGUISHERS

## 2-17. Introduction

Portable fire extinguishers are normally used as first aid firefighting devices for fighting small fires. They often prevent catastrophes. These extinguishers are **placed** in buildings and other places where there is a fire hazard. **Firefighters** also carry them on fire apparatus because their extinguishing agents are more effective and better suited under some conditions and for certain materials such as combustible metals. These extinguishers are available in a number of shapes and sizes and contain **different** agents for various types of fires. The different extinguishers require different individual procedures for inspection, operation, and application. The following are the type of extinguishers most commonly used :

- a. Carbon dioxide ( $\text{CO}_2$ ).
- b. Pump type water.
- c. Pressurized water.
- d. Soda-acid.
- e. Foam.
- f. Bromotrifluoromethane ( $\text{CF}_3\text{Br}$ )
- g. Dry chemical.

## 2-18. Inspection

Fire extinguishers must be kept in good operating condition and thus require periodic **inspection**. When making an inspection of any type of fire extinguisher, take the **following** action : Examine the surroundings to check that the extinguisher is accessible under actual fire conditions, and that it is not subject to possible mechanical injury. Have all obstructions removed which may hide the extinguisher from view or delay its use. If necessary, change the type of extinguisher or add new units. See that the extinguisher is located in the right place to meet the existing fire regulations. Check the hanging bracket or support for security. Replace, tighten, or strengthen the hanging bracket or support, if necessary, and see that the extinguisher is easily removable.

## 2-19. Carbon Dioxide Extinguishers

Carbon dioxide ( $\text{CO}_2$ ), the extinguishing agent used in the  $\text{CO}_2$  extinguisher illustrated in figure 2-51, is a gas about  $1\frac{1}{2}$  times heavier than air. It is nonpoisonous, and will not support combustion or sustain life.  $\text{CO}_2$  converts to a liquid when under pressure in an individual extinguisher or when refrigerated, as in the bulk storage tank.

a. In operating a  $\text{CO}_2$  extinguisher, break the wire seal and remove the safety pin. Hold the extinguisher by the **carrying** handle in one hand with the thumb or **palm** resting on the shutoff valve lever. Direct the discharge horn with the other hand, holding the horn by the rubber or wooden handle. Squeeze the shutoff valve lever to operate. Direct the discharge at the base of the fire. On flammable liquids fires, sweep the discharge across the burning surface, starting at the front and working from side to side and front to rear.  $\text{CO}_2$  extinguisher discharge valves should be opened fully and the entire contents should be **dis-**

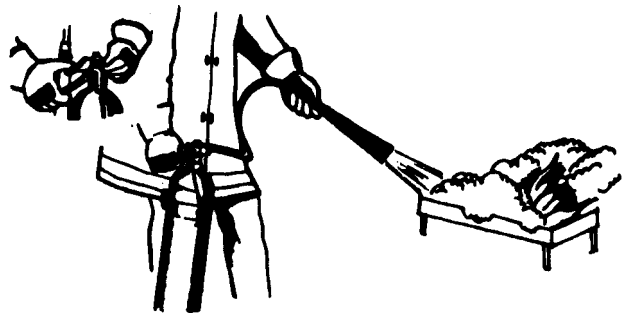

**Pulling the pin, and discharging the carbon dioxide Extinguisher.**

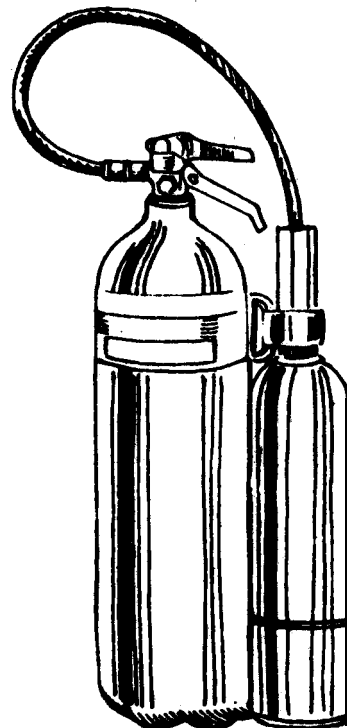

**Figure 2-51.  $\text{CO}_2$  extinguisher.**

charged when fighting flammable liquids fires to give maximum protection against flashback.

b. The CO<sub>2</sub> smothers the fire by cutting off air. The cooling effect is negligible in firefighting.

c. The carbon dioxide extinguisher has an effective range of from 3 to 8 feet (0.914 to 2.44 meters). It must not be stored where temperatures exceed 120° F. (29° C.) as the internal pressure increases in the cylinder. Pressure increases from about 960 psi (67.6 kilograms per square centimeter) at 80° F. (26.7° centigrade) to about 1450 psi (102 kilograms per square centimeter) at 100° F. (38° C). The cylinder contains rupture disks which will rupture at a pressure of between 2400 and 2600 psi (169 and 183 kilograms per square centimeter). Hold the discharge horn only by the insulating rubber or wooden handle. The temperature of the discharging gas is about -110° F. (-79° C) and frostbite can occur from contact with the horn. The horn also builds up a charge of static electricity, particularly with extinguishers having a high discharge rate. Static buildup can be avoided by touching the extinguisher shell to the ground during discharge. Carbon dioxide extinguishers with metal horns are not rated for Class C fires. When operating on a Class C fire be careful to keep the extinguisher shell away from energized electrical equipment.

d. The CO<sub>2</sub> extinguisher should be recharged after each use. The refill (CO<sub>2</sub>) is compressed into the cylinder, usually by a commercial supplier, up to the prescribed full weight.

e. In the monthly inspections, the following is checked: the horn, the discharge hose, the exterior of the shell for defects, and the seal to see if it has been broken. In the annual inspection, the cylinder is weighed in addition to the monthly inspection procedure. If the weight has dropped more than 10 percent of the difference between the full and empty weight, the extinguisher must be recharged. The full weight and empty weight are stamped on the cylinder or shown on a label attached to the cylinder. A hydrostatic test of the cylinder must be performed every 5 years, 12 years if it has not been discharged.

## 2-20. Pump Type Water Extinguishers

Pump type water extinguishers (fig. 2-52) are the most common type and are made in the 2½-gallon (9.46-liter), 4-gallon (15-liter), and 5-gallon (19-liter) sizes. Almost all of these extinguishers are operated by a hand pump built into the tank. All

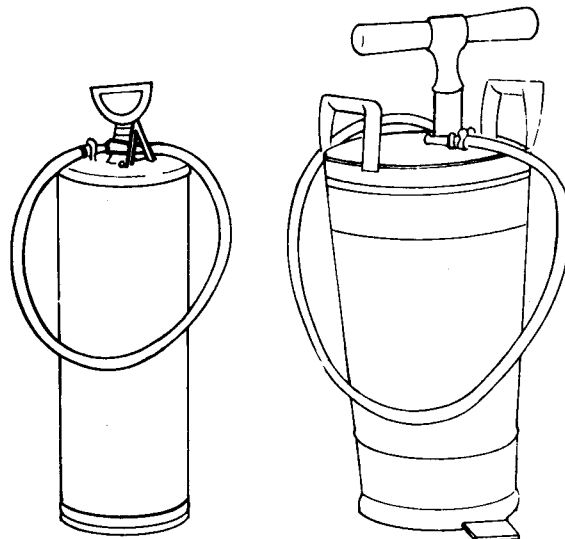

Figure 2-52. Pump type water extinguisher.

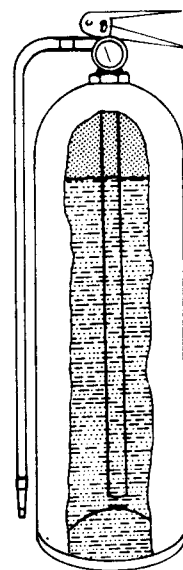

Figure 2-53. Pressurized water extinguisher.

pump type extinguishers are charged with water only, except when they are installed in temperatures requiring the addition of antifreeze compounds. These extinguishers vary in size and shape, but basically all of them operate in the same way and contain a tank, a pump, a hose, and a nozzle. A 5-gallon (19-liter) backpack extinguisher is available for brush or forest firefighting.

## 2-21. Pressurized Water Extinguishers

Pressurized water extinguishers are one of the new kinds of fire extinguishers. The pressurized water extinguishers used by the Army are of the

2½-gallon (9.46-liter) size (fig. 2-53). The extinguisher consists of a tank, discharge valve, pickup tube, hose and nozzle, and pressure gage. Nitrogen or air pressure of 100 psi (7 kilograms per square centimeter) is used to discharge the water.

a. To operate the pressurized water extinguisher, pull the safety locking pin out, depress the operating handle, and direct the stream at the base of the fire, moving often enough so that as much of the fuel as possible is covered with water.

b. To perform a monthly inspection, check the wire and lead seal for damage, the air pressure gage for deviation from the correct pressure reading of 100 psi (7 kilograms per square centimeter), and the hose and nozzle for foreign objects. The semiannual and annual inspections are similar in scope to the monthly inspection.

c. To recharge the pressurized water extinguisher, first remove the discharge valve and attach the pickup tube. Then fill the tank with 2½ gallons (9.46 liters) of water, lubricate the gasket in the neck of the discharge valve, replace the discharge valve and pickup tube, and apply the proper air pressure (100 psi, 7 kilograms per square centimeter).

d. The extinguisher must be hydrostatically tested every 5 years.

## 2-22. Soda-Acid Extinguishers

In the 2½-gallon (9.46-liter) soda-acid extinguisher (fig. 2-54), water is the extinguishing agent, and a chemical combination generates enough pressure to discharge the water. The tank contains a solution of sodium bicarbonate and, supported in the top of the reservoir, a glass bottle containing 4 ounces (118 milliliters) of sulfuric acid. When brought together, these two chemicals produce carbon dioxide gas, which expels the water. A loose stopper in the mouth of the acid bottle retards the absorption of moisture by the acid. When the extinguisher is turned upside down, the loose stopper falls partially clear of the acid bottle and allows the contents of the bottle to mix with the soda solution. The taper of the stopper regulates the flow of acid and prevents sudden high pressures. The rate of flow insures chemical reaction of all the acid before the solution is discharged from the extinguisher. The soda-acid extinguisher also has a hose and nozzle and a threaded cap which contains the necessary gasket.

a. To operate the 2½-gallon (9.46-liter) soda-acid extinguisher, grasp the nozzle and invert the

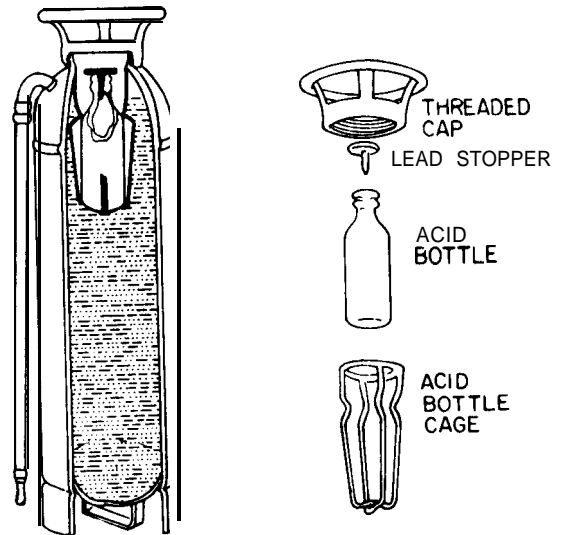

Figure 2-54. Soda-acid extinguisher.

extinguisher. The chemical reaction and pressure occur almost immediately after tilting, causing discharge of the agent.

b. The monthly inspection of the soda-acid extinguisher includes checking the hose and nozzle for obstruction, removing the cap to assure the presence of the proper agent, and recording the entry on the extinguisher tag. The annual inspection requires discharging, cleaning, and recharging the tank.

c. To recharge the soda-acid extinguisher remove the cap, acid bottle, and bottle cage; wash all parts thoroughly; and check to see that all of the liquid is removed from the acid bottle before water or acid is added. Dissolve 1½ pounds (0.68 kilogram) of bicarbonate of soda in 7 quarts (6.5 liters) of lukewarm water. Pour the solution into the extinguisher and add fresh water to the level of the special marker on the inner wall of the extinguisher. The extinguisher when filled to the top of the collar holds 3 gallons (11.4 liters), but it must never be charged with more than 2½ gallons (9.46 liters) of liquid. Pour 4 fluid ounces (118 milliliters) of concentrated sulfuric acid into the bottle. A plainly etched line in the bottle shows the 4-ounce (118-milliliter) level. Insert the lead stopper in the acid bottle and place it in the cage; then insert the cage and bottle in the extinguisher. Be certain that the cage, bottle, and stopper are those made for that particular extinguisher. Manufacturers are not necessarily standard in the shaping of their extinguishers, and many of the parts are not interchangeable. Next examine the gasket in the cap. Replace the gasket

with a new one if it is rigid or defective. **Finally** screw the cap down hand-tight on the collar. See TM 5-687 for further details.

d. The soda-acid extinguisher must be hydrostatically tested every 5 years.

e. The soda-acid extinguisher has been taken out of TB 5-4200-200-10, and therefore, has been discontinued as Army issue equipment. The pump type water extinguisher is taking its place.

### 2-23. Foam Extinguishers

The 2½-gallon (9.46-liter) foam extinguisher illustrated in figure 2-55 is similar in size and appearance to the 2½-gallon (9.46-liter) soda-acid extinguisher, but it differs in internal construction, extinguishing agent, and charging procedure.

CL. This type extinguisher consists of an inner chamber and an outer chamber. The outer chamber contains a solution of sodium bicarbonate, and the inner chamber contains a solution of aluminum sulfate. Ingredients added to the soda solution assist in forming and stabilizing the foam. The extinguisher is operated by inverting it, allowing the contents of the two chambers to mix. This reaction produces bubbles containing carbon dioxide gas, with the stabilizing ingredients strengthening the bubble structure and producing foam. This foam is expelled from the extinguisher by the carbon dioxide gas pressure.

b. To operate the extinguisher, simply grasp the hose, invert the extinguisher, and direct the foam at the base or forward part of the flame. Allow

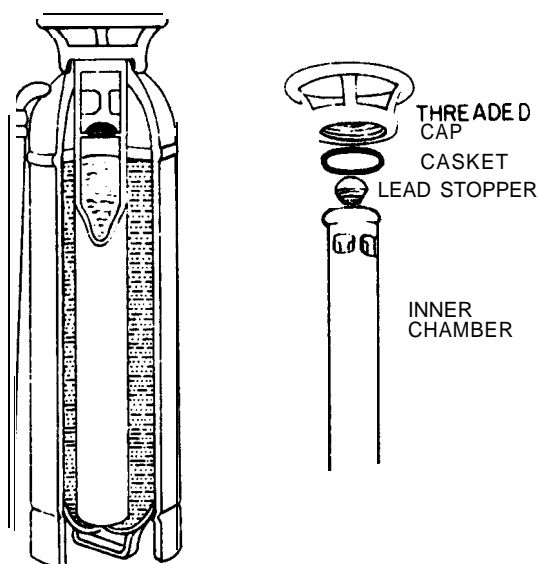

Figure 2-55. Foam extinguisher.

the foam to flow over the surface of the fire area as a smothering blanket.

c. The monthly inspection of the foam extinguisher includes carefully examining the nozzle for stoppage, since the contents of the extinguisher frequently plug the nozzle; inspecting the hose and tank for deterioration; and checking for the proper amount of fluid by weight or internal observation. On the semiannual inspection, **perform** the monthly services and also check the inner chamber for corrosion by removing the cap. Replace the inner or outer chamber, if required. Check the inner chamber stopper for freedom of movement and look for gasket breaks or deep grooves worn by the filler collar. Replace the gasket in the cap, if necessary. Examine the filler collar for dents and for the presence of foreign matter. The annual inspection includes all of the preceding services plus the discharging and recharging of all foam extinguishers. See TM 5-687 for further details.

d. To recharge the 2½-gallon (9.46-liter) foam extinguisher make sure that the two solutions are in accordance with the instructions printed on the chemical containers. Usually the chemicals are in two containers marked "A" and "B". The solutions should be prepared in separate containers. In the absence of such instructions, dissolve the contents of package "A" in exactly 2¼ pints (1.064 liters) of hot water and pour it into the inner chamber. Dissolve the contents of package "B" in exactly 1¾ gallons (6.624 liters) of lukewarm water and pour this solution into the outer chamber. Do not use hot water with the contents of package "B" because it deteriorates with heat. Place the stopper in the inner chamber and assemble the extinguisher.

e. The foam extinguisher should be hydrostatically tested every 5 years.

f. The foam extinguisher has been discontinued as Army issue equipment. The ones in use will be phased out in time.

### 2-24. Bromotrifluoromethane Extinguisher (Vaporizing liquids)

The  $\text{CF}_3\text{Br}$  extinguisher, figure 2-56, commonly known as FREON 1301, contains a liquefied compressed gas which offers unusual advantages as a safe and efficient fire extinguishing agent particularly against Class B (flammable liquid) and Class C (electrical) fires. The liquid has a boiling point of  $-72^\circ\text{F}$ . ( $-56.8^\circ\text{C}$ .), and a freezing point of  $-270^\circ\text{F}$ . ( $-167.78^\circ\text{C}$ .).



Figure 2-56.  $CF_3Br$  extinguisher.

a.  $CF_3Br$  is not toxic in its natural state. Decomposition occurs at fire temperatures and the products of decomposition are toxic. These products are injurious if they exceed 10 percent of the air volume. Normally, extinguishment can be accomplished with less than 5 percent per volume of air. It should be used with caution in confined spaces.  $CF_3Br$  decomposes partly when subjected to heat and flame, which causes a decrease in its toxicity limits.  $CF_3Br$  is noncorrosive on metals and alloys, and is considered a clean agent.

b. The only  $CF_3Br$  extinguisher in the Army inventory is of the  $2\frac{3}{4}$ -pound (1.25-kilogram) size, which has the same extinguishing ability as the 5-pound (2.27-kilogram)  $CO_2$  unit.

c. Because of the low vapor pressure of  $CF_3Br$  at ambient temperatures, the extinguisher is pressurized to 400 psi (28 kilograms per square centimeter) with nitrogen. This pressure is sufficient to permit use of the extinguisher at  $-65^\circ F.$  ( $-54^\circ C.$ ) without further modification.

d. The  $CF_3Br$  extinguisher must be kept fully charged at all times. Reweighing is the only method of determining whether or not the extinguisher is fully charged. The extinguisher should

be weighed **semiannually** on an accurate scale to determine leakage. The cylinder assembly must be replaced if it has lost more weight than is permitted by the instructions on the extinguisher nameplate. Recharging is necessary if the weight is found to be 10 percent deficient. The date of recharging should be stenciled on the cylinder.

e. Where extinguishers of this type are used, charged cylinder assemblies should be kept on hand so the extinguisher may be promptly recharged after use.

f. These extinguishers should not be located where the ambient temperature will exceed  $150^\circ F.$  ( $65^\circ C.$ ).

## 2-25. Dry Chemical Extinguishers

Dry chemical portable fire extinguishers vary from  $2\frac{1}{2}$  pounds to 150 pounds (1.134 kilograms to 68 kilograms). The dry chemical compound used consists principally of bicarbonate of soda or potassium bicarbonate or ammonia phosphate which has been treated to make it waterproof and free flowing. The extinguishing action of this agent is to smother the fire.

a. Dry chemical extinguishers are of two basic types. One type is pressurized with 150 psi (10.5 kilograms per square centimeter) of dry nitrogen or dry air, and the other has a cartridge with  $CO_2$  under pressure. When the cartridge of the second type is punctured,  $CO_2$  pressure expels the agent (fig. 2-57).

b. To operate the pressurized dry chemical extinguisher, break the **sealing** wire, remove the locking pin, depress the operating handle, and direct the agent at or close to the base of the fire. To operate the cartridge dry chemical **extin-**

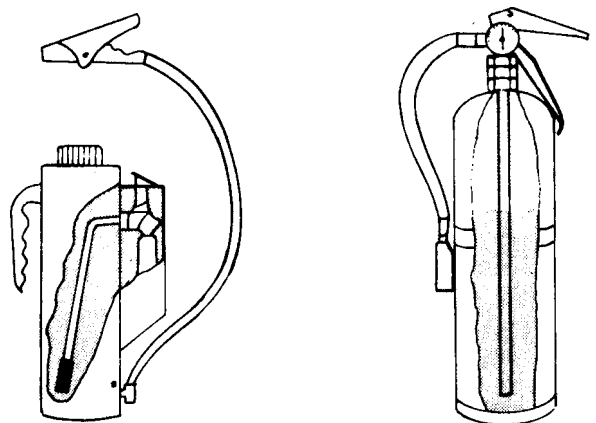

Figure 2-57. Dry chemical extinguisher.

**guisher**, break the sealing wire, remove the locking pin, depress the cartridge-puncturing handle, and direct the agent at or close to the base of the fire.

c. When performing a monthly inspection, check the sealing wire and seal, the dry nitrogen pressure gage for the correct pressure of 160 psi (10.6 kilograms per square centimeter) (pressurized type), and the hose and nozzle for foreign objects. The semiannual and annual inspections compare with the monthly inspections, with the one exception that the cartridge of the nonpressurized extinguisher must be weighed during the annual inspection. If the weight of the cartridge contents (as stamped on the cylinder) is 10 percent or more below the prescribed weight, the cartridge should be replaced. See TM 5-687 for further details.

d. The dry chemical extinguisher should be hydrostatically tested every 5 years.

## 2-26. Combustible Metal Agents

Two extinguishing agents are listed for use on Class D (combustible metal) fires. They are available in drums or barrels and put on the fire with a scoop or shovel. A cover of at least  $\frac{1}{2}$  inch (1.27 centimeters) of extinguishing agent is applied to the burning agents. The two agents are:

a. **G-1 Powder.** This is screened graphitized foundry coke with various phosphates added. It includes particles of various sizes to aid in packing. The material acts as a heat conductor to lower temperature of the burning metal and forms a coating to smother the fire by excluding air. It also produces a gas to aid in smothering. It may be used on magnesium and magnesium alloy fires.

b. **Met-L-X Powder.** This has a sodium chloride base with additives to give water repellancy and good flow characteristics. An additive fuses at high temperatures to aid in forming an airtight coating. This material forms a coating to exclude air, which smothers the fire. It also conducts some heat away from the burning metal. It may be used on magnesium, sodium, potassium, and sodium-potassium alloy (NaK) fires.

## 2-27. Dry Power Extinguishers for Combustible Metal Fires

a. Dry powder extinguishers also use the Met-L-X sodium chloride dry powder described in the

preceding paragraph. It is dispensed with a 30-pound (13.6-kilogram) capacity extinguisher (fig. 248). This amount of rated D agent is effective on about 6 pounds (2.7 kilograms) of burning metal, depending on the type and form of the metal. Only cartridge-operated units are available. The dry powder extinguisher is operated by removing the hose which is around the puncturing mechanism, then depressing the plunger which punctures the cartridge. The compressed gas in the cartridge is released into the shell, thus pressurizing it. The gas pressure expels the dry powder from the shell when a nozzle shutoff is opened. This pressurizes the shell. The extinguisher is carried by its handle with one hand and the nozzle and shutoff valves are operated with the other hand. The shutoff valve is squeezed to open it and released to stop the flow of the agent. The normal operation is to open the nozzle partially to obtain a soft flow of the agent. The burning metal is covered with at least one  $\frac{1}{2}$  (1.27 centimeters) of the Met-L-X sodium chloride. If glowing spots appear, they should be recoated. The application of this agent forms a crust over the burning metal which excludes the air and thus smothers the fire. The effective range of the extinguisher is from 3 to 5 feet (0.9 to 1.5 meters).

b. The dry powder extinguisher should be recharged after each use. First, the gas pressure is released by turning the extinguisher upside down and opening the shutoff valve. This will not release the agent remaining in the extinguisher. Next, the extinguisher is disassembled according to the manufacturer's instructions and cleaned

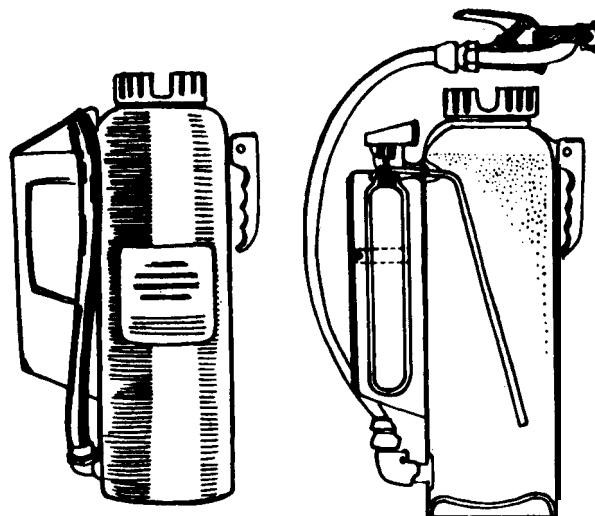

Figure 2-58. Exterior and cutaway views of a dry powder extinguisher.



with a brush or **compressed** air. Then the shell is filled with the proper amount of dry powder. In reassembling, check the gasket, insert a new cartridge, seal the extinguisher, and tag it.

c. The monthly inspection includes checking the nozzle, the hose, the shell for defects, and the seal to assure that it has not been broken. The annual inspection requires a thorough check of all component parts and the weighing of the cartridge on an accurate scale calibrated in fractions of an ounce (or grams). The cartridge is replaced if it has lost  $\frac{1}{2}$  ounce (14 grams) or **more**. A hydrostatic test must be performed on the extinguisher shell and the hose every 5 years.

d. Do not confuse the dry powder extinguisher with the dry chemical type extinguisher.

## 2-28. Winterization of Extinguishers

The protection of fire extinguishers from freezing is extremely **important** and should be thoroughly understood by all fire protection personnel.

a. Carbon dioxide extinguishers which must be operated in temperatures below  $0^{\circ}$  F. ( $17.8^{\circ}$  C.) must be winterized. This winterization is essential because when the temperature falls below  $0^{\circ}$  F. ( $17.8^{\circ}$  C.), the pressure of the extinguisher also falls below **285** pounds per square inch (20 kilograms per square centimeter), which is the minimum amount of pressure needed for proper operation. The winterization of  $\text{CO}_2$  extinguishers requires the addition of 200 pounds (90.7 kilograms) of pressure per square inch (14 kilograms per square centimeter), which is done by adding dry nitrogen to the  $\text{CO}_2$ . Local directives should be consulted as to the amount of dry nitrogen to be added. The addition of dry nitrogen requires a decrease in the amount of  $\text{CO}_2$  in the cylinder. The dry nitrogen provides additional pressure for expelling  $\text{CO}_2$  at low temperature. Since the decrease of the  $\text{CO}_2$  will not allow the addition of dry nitrogen pressure to rupture the cylinder gravity disk until the temperature reaches  $160^{\circ}$  F. ( $71^{\circ}$  C.), the injection of dry nitrogen allows the

extinguisher to operate in temperatures higher than in those permitted by  $\text{CO}_2$  gas, as well as in temperatures lower than in those permitted by  $\text{CO}_2$  gas.

b. The prescribed chemical for lowering the freezing point of water in water-type extinguishers is calcium chloride. The quantity of calcium chloride required to prevent freezing will vary from 3 pounds per gallon (0.362 kilogram per liter) of water to protect against a temperature of  $2^{\circ}$  F. ( $-16.9^{\circ}$  C.), to a **maximum** of **5** pounds per gallon (0.6 kilogram per liter) of water to protect against a temperature of  $-53^{\circ}$  F. ( $-47^{\circ}$  C.) (TM 5-687). Local directives should be consulted for **specific** amounts at each temperature level. **Before** winterization, extinguishers which require the use of calcium chloride solutions should have the interior of the water tank painted **with** two coats of asphaltum base paint to retard corrosive action. Dry calcium chloride should not be placed directly into the appliance to be winterized. The chemical should be mixed with water in a separate container to prevent caking at the bottom of the tank. A  $\frac{1}{4}$  ounce of **sodium** bichromate added to each gallon (1.87 grains per liter) of water will act as a rust inhibitor. Do not antifreeze pressurized water extinguishers with calcium chloride. Use specially prepared solution.

c. Since soda-acid and foam extinguishers depend on a chemical reaction to expel the extinguishing agent, winterizing chemicals are not used. Therefore, soda-acid and foam extinguishers are normally located only in heated structures.

d. Pressurized dry chemical extinguishers do not require winterization. Cartridge type dry chemical extinguishers are winterized by replacing the  $\text{CO}_2$  filled cartridge with one filled with dry nitrogen.

### NOTE

See TB 5 **4200-200-10** for hand portable fire extinguishers approved for Army users.

## CHAPTER 3

## CHARACTERISTICS, CHEMISTRY, AND PHYSICS OF FIRE

**3-1. Introduction**

The number of fires caused by uncontrollable natural reactions is minimal in relation to those caused by the carelessness of man and his apathy in acquiring and using the information available on the characteristics, chemistry, and physics of fire. The knowledge of the principles of fire also helps the firefighter in extinguishing those fires that he fails to prevent.

**3-2. The Nature of Fire**

Previously, the process of chemical oxidation and combustion and that of halting combustion was shown with the familiar fire triangle (fig. 3-1). This two-dimensional triangle aided in explaining the combustion process. Thus, when all the sides of the fire triangle were intact and in proper state and proportion, burning took place. When any one of the sides (factors) was removed, burning was stopped. Before the introduction of the modern knowledge on chemical fire extinguishment, there were only three methods of extinguishing a fire, aligned closely with each leg of the fire triangle. Cooling the fire removed the "heat leg"; excluding the oxygen from the fire removed the "oxygen leg"; and separating the fuel from the fire removed the "fuel leg". When chemical extinguishing agents were introduced and successfully used for fire extinguishment, additional information was required to explain the action of the chemical. This new information added another dimension to the diagram. The new diagram is known as the *tetrahedron of fire* (fig. 3-2). It has four triangular surfaces that make up a solid pyramidal form which has depth. Each of the triangular surfaces shows an element necessary to continue combustion. It shows that combustion (**fire**) is a continuous chemical reaction which changes constantly because of external conditions. Chemical extinguishment agents (**potassium** and sodium bicarbonate type dry chemicals or vaporizing liquid agents) inhibit the chain reaction of a fire by interfering with or cutting off the conditions **nec-**



Figure 3-1. The fire triangle.

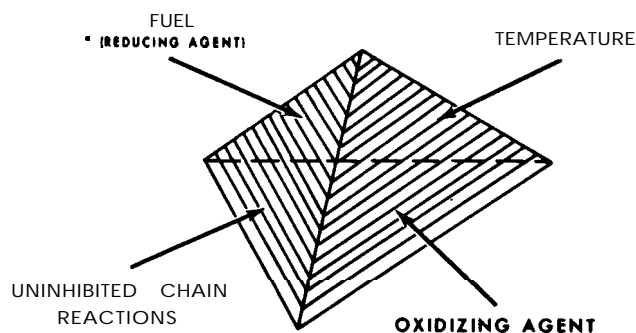

(Courtesy Walter M. Haessler, *The*  
Figure 3-2. The tetrahedron of fire.

essary for combustion. Thus, all the three parts of the fire triangle may be present, but the chain reactions are prevented (inhibited) by a chemical extinguishment agent (or agents) which puts out the flame.

**3-3. Basic Definitions and Properties of Fire**

**a. Ignition Temperature.** The ignition temperature of a substance (solid, liquid, or gaseous) is the minimum temperature to which the substance exposed to air must be heated in order to **initiate** or cause self-sustained combustion. Ignition temperatures of the same substance vary according to the percentage composition of the vapor or **gas-**

air mixture, shape, and size, of space where the ignition occurs, rate and duration of heat, kind and temperature of the ignition source, oxygen concentration, and other effects of materials that may be present. Therefore, given ignition temperatures should be looked upon as approximations.

*b. Vapors.* Vapors in the process of combustion are the gaseous substance given off by the material that is burning. In burning wood, heat causes the resinous substance in the wood to vaporize. The vapors combine with the oxygen of the air, and the flame from the kindling ignites the combustible vapor-oxygen gas. The heat from the fire heats the wood, which in turn liberates more vapors and thus sustains the fire until the wood is consumed.

*c. Vapor Density.* Vapor density is the term used to explain the weight of vapors. When speaking of the weight of these vapors, they are usually compared to air, which has a vapor density of 1. Therefore, if a substance has a vapor density of 1.5, it is  $1\frac{1}{2}$  times as heavy as air. If it has a vapor density of .5, it weighs only  $\frac{1}{2}$  as much as air. Figure 3-3 shows how the density of gasoline vapors can be demonstrated with a small trough, a candle, and a gasoline-soaked rag. A lighted candle (the ignition source) is placed at the lower end of the trough, and the gasoline-soaked rag placed at the upper end. Gasoline vapors are heavier than air and will flow down through the trough to the lighted candle, where they will ignite, and flash back to the rag at the top of the trough. This illustration shows the need for the "No smoking within 100 feet" signs displayed around gasoline storage areas.

*d. Flammable or Explosive Limits.* In the case

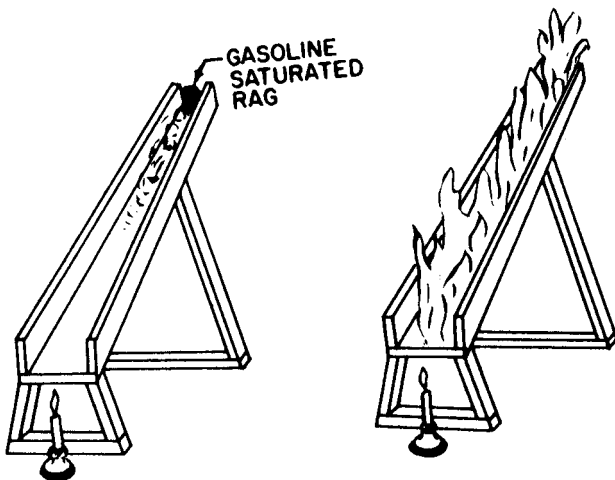

Figure 3-3 Vapor density.

of gases or vapors which form flammable mixtures with air (or oxygen), there is a minimum concentration of vapor in air below which flame does not occur when the vapor-air mixture comes in contact with a source of ignition; thus, it is too "lean" to ignite. Most flammable vapors and gases also have a maximum proportion of vapor or gas in air above which flame does not occur (too "rich" to ignite). A few materials, like ethylene oxide, decompose and burn with no oxygen present.

*e. Flammable (Explosive) Range.* The range of combustible vapor or gas-air mixtures between the upper and lower flammable limits is known as the "flammable range" (or "explosive range"). For example, the lower limit of flammability of acrylonitrile at ordinary ambient temperatures is approximately 3 percent vapor in air by volume. The upper limit of flammability is about 17 percent. Thus, all concentrations of acrylonitrile vapor in air falling between 3 and 17 percent are in the flammable or explosive range.

*f. Flash Point and Fire Point.* The flash point of a liquid is the lowest temperature of the liquid at which it gives off vapor sufficient to cause a flammable mixture with the air near the surface of the liquid or within the vessel used. Some solids, such as camphor and naphthalene, change from solid to a vapor at ordinary room temperature and therefore have flash points while still in the solid state. The fire point (the lowest temperature at which a substance continues to burn in air) is usually a few degrees above the flash point.

## 34. Principles of Fire

*a. Ignition and Combustion.* Fire or combustion may be described as rapid oxidation with the action (evolution) of heat and light. Oxidation of a material takes place continuously as long as it is exposed to an oxidizing agent, which may be air. At ambient temperatures, oxidation is usually so slow that the process is not noticeable to human senses. Examples of such slow oxidation are the rusting of iron and the yellowing of paper. As temperatures rise above the ambient, the rate of oxidation becomes more rapid and generates heat. When the ignition temperature is reached, flame appears, thus ignition has taken place. Combustion is the continuous burning that follows after ignition.

*b. Fire.* Actual burning (fire) is a much more complicated chemical reaction than is commonly explained by the "fire triangle" (fig. 3-1) or the

more recent “tetrahedron of fire” fig. (3-2). As the temperatures rise above the ambient, pyrolysis takes place. Pyrolysis is the chemical decomposition of matter through the action of heat. It proceeds through the following stages:

(1) Decomposition of combustible material slowly gives off gases, including water vapor. The combustible gases are not ignitable during the early stages of pyrolysis.

(2) Gas evolution continues with some of the gas becoming ignitable. As the temperature increases the gas **evolution also** increases.

(3) At the ignition temperature the evolved gases are too rich, at first, in carbon dioxide and water vapor to sustain flame very long. However, the heat of the flame starts a secondary pyrolysis reaction process and flaming combustion occurs entirely in the gaseous distillate vapor phase. Gas evolution may be so fast that it blankets the fuel surface and excludes air. This prevents the char from burning, retards the penetration of heat, and delays the ignition temperatures in penetrating deeper into the combustible material. As temperatures increase, the char begins to glow, air flows in to support combustion, and the fuel itself burns as well as its decomposition gases. If the released heat is concentrated and sufficient to sustain oxidation, and more heat is generated than lost through conduction, convection, or radiation, a positive heat balance exists. If, however, most or all of the heat generated is lost, there is a negative heat balance and the fire goes out as a match flame in a wind. At the same time, a condition known as feedback may exist. Feedback is generated heat that prepares adjacent combustible material for burning by raising it to ignition temperatures. If the feedback is not adequate, the fire goes out. In addition to heat generation during pyrolysis, the concentration of the oxidizing agent is another factor that determines whether or not ignition and combustion can occur. There appears to be a minimal oxidizing agent concentration for almost all materials below which combustion will not take place. Exceptions to the latter are some combustible solids, such as cellulose nitrate, that contain oxygen in the constituent molecules. This oxygen can be released by heat even if there is no air supply. Thus, **pyrolysis** reaction may take place without the presence of air. An example is charcoal in coking ovens which continues to oxidize and produce heat with a minimal amount of air.

**c. Summary of the Principles of Fire.** The principles of fire may be summarized as follows:

(1) There must be an oxidizing agent, combustible material, and a source of ignition for combustion to take place.

(2) Combustible material must be heated to its ignition temperature before it will burn.

(3) Combustion will continue until-

(a) The combustible material is removed or consumed.

(b) The oxidation agent concentration is lowered below that essential.

(c) The combustible material is cooled below its ignition temperature.

### 3-5. Heat Energy Sources

Since fire prevention and extinguishment are dependent on the control of heat energy, it is essential that firefighters know the common ways in which heat can be produced. The following discusses briefly the heat energy sources.

a. **Chemical Heat Energy.** This source of heat is the result of oxidation, and is of primary concern to fire protection engineers. The following are the different ways heat is produced through the chemical process:

(1) **Combustion.** Heat of combustion is the quantity of heat released during the oxidation of a substance (fuel). This is the heat normally utilized by industry and for domestic use, and is measured in terms of British thermal units (BTU). The heat intensity of oxidation (complete or partial) of almost all compounds of carbon, hydrogen, and oxygen depends on the oxygen consumed. Thus, the heat produced by combustion is limited by the air supply.

(2) **Spontaneous heat.** Practically all organic substances which are capable of combining with oxygen will oxidize at some critical temperature with evolution of heat if exposed to the atmosphere. The rate of oxidation at normal temperatures is usually slow and the heat which is released is transferred to its surroundings. This keeps the temperature down and prevents ignition. This is not true of all combustible materials. The oxidation of some material generates heat more rapidly than it can dissipate, which results in spontaneous combustion. Enough air must be available to permit oxidation, yet not so much that the heat is carried away by convection as rapidly as it is formed. Oily rags might heat spontaneously in a wastebasket, but would not do so if these rags were hung on a line where air movement is sufficient to remove the heat. Again, a tightly packed bale of rags is not as likely to

cause spontaneous combustion as a loose bale. Because of the many possible combinations of air supply and insulation, no positive **prediction** can be made as to when material will heat spontaneously. Fire safety engineers should not only be aware of the possibility of spontaneous combustion and fires caused by oily rags, paper, coal piles, and foam rubber, but also be aware that oxidation of agricultural products can produce fires by spontaneous combustion. Grains in large piles or bins and piles of grass (hay) will oxidize to a point of ignition when saturated with a certain amount of moisture. Fires from this source may not be as prevalent on farms as in urban areas where the agricultural products are stored.

(3) **Decomposition.** Heat of decomposition is the heat released by the decomposition of compounds such as cellulose nitrate and many commercial and military explosives.

(4) **Solution.** Heat of solution is the heat produced when a substance is dissolved in a liquid. Most materials release heat when dissolved. Chemicals, such as concentrated sulfuric acid, produce enough heat when dissolved to be dangerous. The chemicals that react in water and release heat are not combustible, but liberate sufficient heat to ignite combustible material nearby.

b. **Electrical Heat Energy.** Electrical heat energy produces heat when an electric current flows through a conductor or when a spark jumps an **airgap**.

(1) **Resistance.** An electric wire or other conductor of electricity offers resistance and thus produces heat. The heat from these causes the oxidation and ignition of nearby combustibles and fire results. Fires of this type are quite common in all areas using electricity as a source of heat and energy.

(2) **Induction.** When an **alternating** current is passed through a wire and induces a current in another wire parallel to it, a form of heat called induction heating is produced if the current-carrying capacity of the second wire is inadequate. Inducted heat is produced by the resistance to the flow of electricity and by molecular friction. An example of the latter is the heat produced in a microwave oven.

(3) **Dielectric.** Dielectric heating is that produced when the insulating materials are imperfect and, therefore, allow a leakage of current. This heats the insulating material which may eventually ignite the nearby combustible material.

(4) **Arcing.** Heat from arcing occurs when an electric circuit which carries a current is in-

terrupted and the current leaps the gap. The temperatures of arcs are very high and may ignite combustible and flammable material in the area.

(5) **Static.** Static electricity (friction **electricity**) is an electrical charge that accumulates on the surfaces of two materials that have been brought together and then separated. One surface becomes charged positively and the other **negatively**. If the two objects are not bonded or grounded, they may accumulate sufficient electricity to discharge a spark. 'The spark produces little heat, but it will ignite flammable vapors, gas, and clouds of combustible dust.

(6) **Lightning.** Lightning is the discharge of electrical charge on one cloud to an opposite charge on another cloud or on the ground. Lightning develops very high temperatures in any material of high resistance which may be in its path.

c. **Mechanical Heat Energy.** Mechanical heat energy, especially friction heat, is responsible for a significant number of fires annually. A few are caused by heat energy released by compression.

(1) **Friction heat.** Friction heat is the result of resistance to motion when two solids are rubbed together. The intensity of heat depends upon the amount of mechanical energy **transformed** to heat and on the rate at which the heat is generated.

(2) **Heat of compression.** This is the heat released when a gas is compressed. A useful purpose of ignition by compression is the diesel engine which needs no spark plugs for ignition. A fire may be caused by directing a jet of compressed air into a pipe. The air is converted to heat which ignites an oil film on the inside surface of the pipe fittings.

d. **Nuclear Heat Energy.** Nuclear heat energy is released from the **nucleus** of the atom. The nucleus is held together by a great force which can be released by bombardment of the nucleus with particles of energy. The bombardment (fission and fusion) releases the energy in the form of tremendous heat and pressure, and also nuclear radiations. In nuclear fission, energy is released by splitting the nucleus. In nuclear fusion, energy is released by the fusion of two nuclei. Nuclear weapons firefighting procedures are discussed in chapter 6.

### 3-6. Classes of Fire

Fires are divided into four main classes: class A, class B, class C, and class D fires. These classes

are based on the combustion characteristics of the ignited material. In most cases, installation fires are combinations of at least two and sometimes all of these classes.

*a. Class A Fires.* Class A fires are fires in ordinary combustible materials such as bedding, mattresses, dunnage, books, cloth, canvas, wood, and paper. Class A fires must be dealt with by cooling the fire below its ignition temperature. All class A fires leave embers which are likely to rekindle if air comes in contact with them. Therefore, a class A fire must not be considered extinguished until the entire mass has been cooled thoroughly. Smothering is not effective for class A fires because it does not lower the temperature of the burning embers below the surface of the fire.

*b. Class B Fires.* Class B fires are those which occur in flammable substances such as gasoline, jet fuels, kerosene, oils, paint, turpentine, grease, tar, and other combustible substances which do not leave embers or ashes. Class B fires can be extinguished by providing a barrier between the burning substance and the air or oxygen necessary for its combustion. Chemical foam and mechanical foam produce such barriers, and are known as "permanent" smothering agents. Carbon dioxide is also a smothering agent, but its effect is only temporary and the application must be renewed if there is any danger of reignition.

*c. Class C Fires.* Class C fires are fires in live

electrical materials. They present an extra hazard to the firefighter, because of the danger of electrical shock. A nonconducting extinguishing agent is essential for fighting class C fires. An additional consideration in fighting class C fires is the fact that it may be quite important to avoid damaging the electrical equipment in the process of extinguishing the fire. Electrical instruments and contacts will be contaminated by any extinguishing agents except gases. The first step in extinguishing a class C fire is to secure the source of power to the circuit or equipment on fire. The preferred agent in fighting class C fires is carbon dioxide or monobromotrifluoromethane, since they give protection against electrical shock and are not likely to injure the equipment. Water fog, although not preferred, may be used; under ordinary conditions it does not transmit electricity to the firefighter (as would a solid stream of water), but it may damage the energized electrical equipment.

*d. Class D Fires.* Class D fires are those in combustible metals, such as titanium, zirconium, sodium, potassium, etc. The greatest hazard exists when these metals are in the molten state or in finely divided forms of dust, trimmings, or shavings. Ordinary extinguishing agents are ineffective on these metal fires, and they are best controlled by covering with special dry powdered or granular materials which exclude oxygen and which will not react or combine adversely with metal.

## CHAPTER 4

## TACTICS AND TECHNIQUES OF FIREFIGHTING

## Section I. FIRE CONTROL

## 4-1. Introduction

Fire control is **defined** as “retarding or reducing the rate of burning.” Extinguishment, on the other hand, is the complete elimination of the fire. Retarding or reducing the rate of burning would seem to be just a step in the process of extinguishment. But it can be an immediate objective in itself, for a successfully controlled fire makes it possible to **rescue** personnel before completely extinguishing the fire. When a building is completely engulfed in flames, the heat makes rescue impossible until it has been reduced by control. In structural firefighting, control is very important especially when rescue of personnel may be necessary or when there is a danger of the fire spreading. Because water is the principal extinguishing agent, the supply limitation is not usually a problem. Instead, water pressure and the volume in gallons per minute are generally the **most** important factors in this phase of fire protection. Another method of control frequently used in structural firefighting is called *covering exposures*. This means that when one **structure** is burning, other structures, especially those downwind, are protected to keep radiation and convection heat from causing these buildings to start burning. To prevent this kind of spreading, streams of water are applied to these exposed buildings. In this sense, then, control means the prevention of spreading rather than the reduction of fire in a particular area.

## 4-2. Fire Control Methods

Three methods are used in the control of fire :

*a.* Cooling or reducing the temperature below the ignition point.

*b.* Smothering or reducing the oxygen content within the fire area below the burnable limits. The atmosphere must contain at least 15 percent oxygen in order for a fire to burn.

*c.* Removing fuel from the vicinity of the fire, by valve or switch action, by the application of heavy streams of water, by firebreaks in the case of natural-cover fires, or by manual removal.

## 4-3. Extinguishment of the Different Classes of Fire

*a.* Class A fires require primarily water or an agent containing water so that the deep-seated embers in wood, cloth, and other class A materials may be reached by the cooling agent.

*b.* Class B fires may be extinguished with carbon dioxide (CO<sub>2</sub>), **monobromotrifluoromethane (CF<sub>3</sub>Br)**, foam (mechanical and chemical), dry chemical (bicarbonate of soda), **potassium bicarbonate (Purple K)**, and ammonium phosphate), methyl bromide, mineral soil, **water-fog**, aqueous film forming foam (AFFF) (trade name “light water”) or any other system of covering that excludes oxygen. AFFF extinguishes the fire and prevents flashback. Dry chemical **extinguishes** the fire immediately by conditioning the atmosphere, but does not cool the combustibles.

*c.* Class C fires are extinguished by (in order of preference) monobromotrifluoromethane, carbon dioxide, and dry chemical. When selecting an extinguishing agent for class C fires, consideration must be given to the electrical conductivity of the extinguishing agents. None of the substances listed above is a conductor of electricity. It is advisable to use **monobromotrifluoromethane (CF<sub>3</sub>Br)** or carbon dioxide (CO<sub>2</sub>) on class C fires whenever possible. **CF<sub>3</sub>Br** and **CO<sub>2</sub>** leave no residue and will not damage electrical equipment.

## NOTE

One more type of fire to be aware of is the compressed gas fire. ‘Technically this type of fire is rated as class B, and

agents listed for class B fires are used to extinguish it. The safest and best way of controlling this fire is to remove the fuel supply. This prevents the accumulation of explosive vapors that would occur if the fire were extinguished and the fuel

were allowed to continue to flow. Fires involving pressurized flammable gases, especially those heavier than air, such as liquefied (petroleum gases, should not be completely extinguished unless the flow of gas can be immediately stopped.

## Section II. FIRE DEPARTMENT HYDRAULICS

### 4-4. Introduction

Hydraulics is that branch of science which deals with the mechanical properties of water or other liquids and with the application of these properties in engineering. Firefighters, especially pump operators, must understand and be able to apply those principles of hydraulics which are essential to firefighting. Inadequate training or lack of experience in fire hydraulics can be extremely costly in lives and materiel.

### 4-5. Properties of Water

Water, the most common liquid, is also the most effective, in its various forms, for firefighting. To use it most effectively, however, one should know about its physical properties.

a. For all practical purposes, water is not compressible. It requires 30,000 pounds (13,608 kilograms) of pressure per square inch (6.45 square centimeters) to reduce its volume 1 percent. If water has a mineral content (such as salt) or is subjected to different temperatures, its characteristics will differ.

b. Water consists of two parts of hydrogen and one part of oxygen—a fact represented by the common chemical formula  $H_2O$ . One cubic foot (0.6283 cubic meter) of water weighs 62.6 pounds (28.35 kilograms). There are 231 cubic inches (3786.09 cubic centimeters) in 1 gallon (3.785 liters) of water and 1,728 cubic inches (28,312 cubic centimeters) in 1 cubic foot (0.0283 cubic meter) of water. One cubic foot (0.0283 cubic meter) of water contains 7.481 gallons (28.3156 liters). One gallon (3.785 liters) of water weighs 8.35 pounds (3.7876 kilograms). These figures are important and should be remembered.

### 4-6. Volume

It is often necessary to determine the volume of cylindrical and rectangular containers in order to know the weights and capacities of installed or reserve tanks and consequently how long they will

be of use. To compute volume, first find the area of a surface. For a square or rectangle, this is done by multiplying the length by the width ( $A = lw$ ). For a circle, the area is found by multiplying the diameter squared by 0.7854 (i.e.,  $A = D^2 \times 0.7854$ ) or by multiplying the radius squared by 3.1416 (i.e.,  $A = R^2 \times 3.1416$ , commonly written  $A = \pi R^2$ , where the Greek letter  $\pi$  (pi) means 3.1416). In hydraulics, the preferred formula is the first one:  $A = D^2 \times 0.7854$ . When going on from problems dealing with the areas of rectangles and circles to those involving the volumes of cylindrical and rectangular tanks, consider a third dimension, that of height, represented by the symbol  $h$ . The formula for the volume of a rectangular tank is  $V = lwh$ , meaning that the volume is found by multiplying the length by the width by the height. **For example:** How many cubic feet are there in a tank 5 feet (1.525 meters) by 4 feet (1.22 meters) by 10 feet (3.06 meters) Substituting in the formula—

$$\begin{aligned} V &= lwh \\ &= 5 \times 4 \times 10 \\ &= 200 \text{ cubic feet} \end{aligned}$$

### NOTE

When computing volume, all dimensions must be in the same unit of measurement. For example, if the diameter of a cylindrical container is given in inches and the height is given in feet, the height must be converted to inches.

The tank contains 200 cubic feet (5.67 cubic meters), and it then becomes a simple problem to find its contents in gallons (or liters). There are 7.481 gallons in 1 cubic foot (1000 liters in 1 cubic meter), so 7.481 multiplied by 200 equals 1,496.2 gallons (1000 multiplied by 5.67 equals 5670 liters), the number of gallons in a 200-cubic-foot tank. For problems involving volumes of cylindrical tanks, use the formula  $V = D^2 \times 0.7854 \times h$ . **For example:** How many cubic feet are contained in a tank 12 feet (3.66 meters) high and 5 feet (1.525 meters) in diameter?



$$\begin{aligned} V &= D^2 \times 0.7864 \times h \\ &= 5 \times 5 \times 0.7864 \times 12 \\ &= 235.62 \text{ cubic feet} \end{aligned}$$

To find the number of gallons, multiply 235.62 by 7.481 to get approximately 1,763 gallons (6673 liters).

**4-7. Weight**

a. Firefighters must know how to find the weight of a given quantity of water. For example, vehicles with a capacity of 1,000 gallons (3785 liters) actually have 8350 pounds (3785 kilograms) of extinguishing agent aboard (8.35 multiplied by 1,000), or more than 4 tons (3.628 metric tons) of water. Such knowledge would be necessary in making a decision about detouring or crossing a bridge of limited capacity.

b. It is also necessary to be able to determine the weight of a charged hose line, especially when only a limited number of personnel are available to move such a line. The futility of filling a 2½-inch (6.35centimeter) hose with water before trying to move it to the point of operation is revealed after figuring the weight of water in a 50-foot (600 inches ; 1524 centimeters) section. This is done by means of the formula—

$$\begin{aligned} V &= \frac{D^2 \times 0.7854 \times h}{231} \times 8.35 \\ \text{(Metric System : } V &= \frac{D^2 \times 0.7854 \times h}{1000} \times 1) \end{aligned}$$

in which *h* is the length of the hose in inches, *D* is the diameter of the hose in inches, 231 is the number of cubic inches in a gallon (1000 is the number of cubic centimeters in 1 liter), and 8.35 is the weight in pounds of a gallon (1 kilogram is the weight of 1 liter).

The  $V = \frac{6.25 \times .7854 \times 600}{231} \times 8.35$  equals approximately 106 pounds (42.8 kilograms) plus the weight of the hose, which is 65 pounds (29.5 kilograms) per section, a total of approximately 171 pounds (78 kilograms).

c. To pull four 50-foot (1&meter) sections of 2½-inch (6.35-centimeter) hose, totaling something over one-quarter of a ton of hose and water combined, up a ladder, becomes a formidable task. These calculations also show that 1,000 feet (305 meters) of 2½-inch (6.35-centimeter) hose, which is the length often carried on structural pumpers, weighs almost 2 tons (1.8 metric tons) when filled.

**4-0. Pressure**

Water pressure is proportional to the depth of the water, which, in hydraulics, is stated in pounds (or kilograms) per square inch (6.45 square centimeters) . A column of water 1 foot (0.305 meter) high exerts a pressure of 0.434 pound (0.197 kilogram) per square inch (6.45 square centimeters). Two columns of water, each 1 foot (.305 meter) high, one on top of the other, would exert 0.868 pound (0.3937 kilogram) per square inch (6.45 square centimeters) of pressure at the base. In other words, if a column of water 1 square inch in base area and 1 foot high weighs 0.434 pound, the effective pressure in pounds per square inch at any point in a column of water is equal to 0.434 multiplied by the height of the column above that point in terms of feet ; this is expressed as—

$$P = 0.434H$$

in which H is the head in feet. Static pressure is the pressure exerted by water at rest. The static pressure may be determined readily, if the head is known by the formula  $SP = 0.434H$ . Back pressure or gravity pressure indicates the pressure in pounds per square inch (psi) exerted by a head of water against a pump lifting it to an elevated point, The solution is found by the same method—

$$BP = 0.434H$$

**4-9. Rate of Discharge**

The rate of discharge is the quantity of water coming from an opening during a given period of time. It is calculated in gallons per minute (gpm).

a. When the rate of discharge is computed, two items must be considered: the diameter of the opening (nozzle) and the pressure of the flow. The rate of discharge is found by multiplying the diameter squared by the square root of the pressure times the constant 29.7 ; this is expressed as—

$$\text{gpm discharge} = 29.7 \times D^2 \times \sqrt{P}$$

For example, using this formula and table 4-1, if the diameter is 2 inches (5.08 centimeter) and the pressure is 36 psi, then :

$$\begin{aligned} \text{Discharge} &= 29.7 \times D^2 \times \sqrt{P} \\ &= 29.7 \times 2^2 \times \sqrt{36} \\ &= 29.7 \times 4 \times 6 \\ &= 712.8 \text{ gpm (2697.7 liters per minute)} \end{aligned}$$

b. An open hose butt (no nozzle) or an average hydrant outlet is only about 90 percent as efficient as a nozzle tip in terms of water volume dis-

$$\begin{aligned} V &= D^2 \times 0.7854 \times h \\ &= 5 \times 5 \times 0.7854 \times 12 \\ &= 235.62 \text{ cubic feet} \end{aligned}$$

To find the number of gallons, multiply 235.62 by 7.481 to get approximately 1,763 gallons (6673 liters).

**4-7. Weight**

a. Firefighters must know how to find the weight of a given quantity of water. For example, vehicles with a capacity of 1,000 gallons (3785 liters) actually have 8350 pounds (3785 kilograms) of extinguishing agent aboard (8.35 multiplied by 1,000), or more than 4 tons (3.628 metric tons) of water. Such knowledge would be necessary in making a decision about detouring or crossing a bridge of limited capacity.

b. It is also necessary to be able to determine the weight of a charged hose line, especially when only a limited number of personnel are available to move such a line. The futility of filling a 2½-inch (6.35-centimeter) hose with water before trying to move it to the point of operation is revealed after figuring the weight of water in a 50-foot (600 inches; 1524 centimeters) section. This is done by means of the formula—

$$V = \frac{D^2 \times 0.7854 \times h}{231} \times 8.35$$

(Metric System:  $V = \frac{D^2 \times 0.7854 \times h}{1000} \times 1$ )

in which *h* is the length of the hose in inches, *D* is the diameter of the hose in inches, 231 is the number of cubic inches in a gallon (1000 is the number of cubic centimeters in 1 liter), and 8.35 is the weight in pounds of a gallon (1 kilogram is the weight of 1 liter).

The  $V = \frac{6.25 \times .7854 \times 600}{231} \times 8.35$  equals

approximately 106 pounds (42.8 kilograms) plus the weight of the hose, which is 65 pounds (29.5 kilograms) per section, a total of approximately 171 pounds (78 kilograms).

c. To pull four 50-foot (15-meter) sections of 2½-inch (6.35-centimeter) hose, totaling something over one-quarter of a ton of hose and water combined, up a ladder, becomes a formidable task. These calculations also show that 1,000 feet (305 meters) of 2½-inch (6.35-centimeter) hose, which is the length often carried on structural pumpers, weighs almost 2 tons (1.8 metric tons) when filled.

**4-8. Pressure**

Water pressure is proportional to the depth of the water, which, in hydraulics, is stated in pounds (or kilograms) per square inch (6.45 square centimeters). A column of water 1 foot (0.305 meter) high exerts a pressure of 0.434 pound (0.197 kilogram) per square inch (6.45 square centimeters). Two columns of water, each 1 foot (.305 meter) high, one on top of the other, would exert 0.868 pound (0.3937 kilogram) per square inch (6.45 square centimeters) of pressure at the base. In other words, if a column of water 1 square inch in base area and 1 foot high weighs 0.434 pound, the effective pressure in pounds per square inch at any point in a column of water is equal to 0.434 multiplied by the height of the column above that point in terms of feet; this is expressed as—

$$P = 0.434H$$

in which *H* is the head in feet. Static pressure is the pressure exerted by water at rest. The static pressure may be determined readily, if the head is known by the formula  $SP = 0.434H$ . Back pressure or gravity pressure indicates the pressure in pounds per square inch (psi) exerted by a head of water against a pump lifting it to an elevated point. The solution is found by the same method—

$$BP = 0.434H$$

**4-9. Rate of Discharge**

The rate of discharge is the quantity of water coming from an opening during a given period of time. It is calculated in gallons per minute (gpm).

a. When the rate of discharge is computed, two items must be considered: the diameter of the opening (nozzle) and the pressure of the flow. The rate of discharge is found by multiplying the diameter squared by the square root of the pressure times the constant 29.7; this is expressed as—

$$\text{gpm discharge} = 29.7 \times D^2 \times \sqrt{P}$$

For example, using this formula and table 4-1, if the diameter is 2 inches (5.08 centimeter) and the pressure is 36 psi, then:

$$\begin{aligned} \text{Discharge} &= 29.7 \times D^2 \times \sqrt{P} \\ &= 29.7 \times 2^2 \times \sqrt{36} \\ &= 29.7 \times 4 \times 6 \\ &= 712.8 \text{ gpm (2697.7 liters per minute)} \end{aligned}$$

b. An open hose butt (no nozzle) or an average hydrant outlet is only about 90 percent as efficient as a nozzle tip in terms of water volume dis-

Table 4-1. Square Roots of Numbers 1 to 100

n	√n	n	√n	n	√n	n	√n	n	√n
1	1.	21	4.582	41	6.403	61	7.810	81	<b>9.</b>
2	1.414	22	4.690	42	6.480	62	7.874	82	<b>9.055</b>
3	1.732	23	4.795	43	6.567	63	7.937	83	9.110
4	2.	24	4.899	44	6.633	64	8.	84	9.165
5	2.236	25	5.	45	6.708	65	8.062	86	2.219
6	2.449	26	6.099	46	6.782	66	8.124	86	9.273
7	2.646	27	6.196	47	6.855	67	8.185	87	9.327
8	2.828	28	5.291	48	6.928	68	8.246	88	9.380
9	3.	29	5.385	49	7.	69	8.306	89	9.434
10	3.162	30	<b>5.477</b>	<b>50</b>	7.071	70	8.366	90	9.486
11	3.316	31	5.667	51	7.141	71	8.426	91	9.639
12	3.464	32	5.656	52	7.211	72	8.485	92	9.691
13	3.605	33	5.744	53	7.280	73	8.544	93	9.643
14	3.741	34	5.831	64	7.348	74	8.602	94	9.696
15	3.873	35	5.916	55	7.416	75	8.660	95	9.746
16	4.	36	6.	66	7.483	76	8.717	96	9.798
<b>17</b>	4.123	37	6.082	57	7.549	77	8.775	97	9.848
18	4.242	38	6.164	58	7.615	78	8.831	98	9.899
19	4.368	39	6.245	59	7.681	79	8.888	99	9.949
20	4.472	40	6.324	60	7.746	80	8.944	100	10.

charge. So, for calculating open-butt or hydrant discharges in gallons per minute, the formula just applied to nozzle discharge must be multiplied by 0.9. This gives :

$$\text{Discharge} = \sqrt{29.7} \times 0.9 \sqrt{P} \times 0.9$$

Applying this to a hydrant in the above example gives 713 gpm  $\times$  .9, or 64.52 gpm (1428.16 liters per minute). For all practical purposes, 712.8 and 641.52 would be rounded off to 713 (2698 liters) and 642 (1423 liters).

#### 4-10. Drafting

When fire hydrants are not available to supply water for firefighting purposes, it may be possible to obtain water by drafting from a static or semi-static source, such as a pond, lake, or river.

a. This is done by dropping one end of a hard suction hose into the body of water and connecting the other end to the intake side of the pump. The pump is started and a partial vacuum is created within the hard suction hose by a primer. When positive displacement pumps are used, no primer is needed. Atmospheric pressure exerted on the body of water forces the water up through the hard suction hose into the pump. The pump discharges the water, under pressure, through the discharge outlet.

b. Atmospheric pressure at sea level is 14.7 pounds (6.668 kilograms) per square inch (6.45 square centimeters). Water creates a gravity or

head pressure of 0.434 pound (0.1969 kilogram) per square inch (6.45 square centimeters). One pound per square inch has a head of  $1 \div 0.434$  or 2.304 feet (0.703 meter). Therefore, atmospheric pressure of 14.7 psi can raise water to a height of  $14.7 \times 2.304$  or 33.9 feet (10.34 meters) at sea level. However, it must be understood that this figure is theoretical and can be true only where a perfect vacuum can be created. Fire pumps, regardless of condition, cannot create a perfect vacuum. A fire pump in good condition should be able to raise water about 75 percent of the theoretical height, or about 25 feet (7.6 meters) at sea level. Atmospheric pressure decreases as altitude increases at the rate of about 0.5 psi per 1,000 feet (305 meters). At 5,000 feet (1525 meters) altitude, the atmospheric pressure is about 12.2 psi; therefore, water can be raised about 21 feet (6.04 meters) at this altitude.

c. When pumping from draft, be careful to assure that all gaskets are in good condition and seated properly in place. All connections must be tight. An adequate screen should be connected to the hard suction hose to prevent debris in the water from being pulled into the pump.

#### 4-11. Application of Water

Water is the most practical extinguishing agent for ordinary structural fires.

a. It absorbs heat rapidly and with greater capacity than most other agents used for fire ex-

tinguishment. A great amount of heat is required to raise cold water to the boiling point; much more heat is required to change the water to steam. However, only a small fraction of the theoretical maximum cooling effect is used if the water is applied in a solid stream.

**b.** To be effective, water must reach the base of a fire. A stream or spray directed into the smoke does little **more** than cool the atmosphere, unless it eventually falls upon the burning material. For large Class A fires, a **substantial** stream is necessary to penetrate the smoke, flame, and fuel. The most efficient fire stream is one which is forceful and large enough to do the job efficiently without excessive water damage. Solid fire streams project water over a considerable area and extinguish **otherwise** inaccessible fires. The production of this fire stream is the primary concern of the senior man, but is also the responsibility of other crewmen from the nozzle-men to the pump operator.

**c.** Some fires, even structural ones, can be extinguished more efficiently with a spray or fog stream, which requires greater pressure to be effective. Fog streams do not have the range of a straight 'stream, but the heat absorption is greater. Water damage is usually less when fog is used because much of the liquid is dissipated as steam. In a hot, smoky, interior fire, firefighters are usually more efficient and comfortable with a fog **stream** in front of them.

**d.** An efficient firefighter must be able to determine the extinguishment requirements of a fire and know the means available for meeting those requirements.

**e.** Extinguishment is **usually** simple if the fire is reached in the early stage, when it can be **extinguished** with a booster line or portable extinguisher.

**f.** If a fire is not discovered in the early **stage** of burning, extinguishment is usually difficult because the fire stream must not only produce the amount of water required for extinguishment but must also carry through space to the point of use. **Volume** can often be supplied with small streams, but even these streams must have shape and velocity to carry them efficiently to the base of the fire.

**g.** If a fire is not discovered or controlled until the entire building is burning, it can be extinguished only by the use of large quantities of water. Even then, the fire stream must be **con-**

trolled so as to supply the greatest amount of water from a safe distance and yet reach the fire at the point of burning. This stage of the fire required heavy master streams.

**h.** The fast-burning temporary frame structures, which have large areas unbroken by partitions, found on many military installations allow fire to spread rapidly. The use of **1½-inch (3.81 centimeters)** hose streams on most installations depends upon sound judgment resulting from the experience of the senior firefighter. The **1½-inch (3.81-centimeter)** hoses should not be used from pumpers unless ample **2½-inch (6.35-centimeter)** hose is available for support. If in doubt that a **1½-inch (3.81-centimeter)** line is capable of extinguishment, use a **2½-inch (6.35-centimeter)** line. Large streams from monitor nozzles and deluge sets may be used when equipment and adequate water supply are available and when the magnitude of the fire demands it.

#### 4-12. Friction loss

Friction is the resistance to motion between two surfaces in contact.

**a.** The term "friction loss" in fire department hydraulics means the loss of energy or pressure caused by friction. The friction conditions with **which** fire protection personnel are most concerned consist of water **rubbing** against the inside lining of the hose. This causes a turbulence of the water, which in turn sets up another friction, that of water rubbing against water.

**b.** The rubber linings of the hose appear perfectly smooth to the naked eye. But **microscopic** observation of hose linings shows a series of irregularities **which** increase in size as water pressure is exerted on the interior of the hose. These irregularities impede the speed of the water as it travels through the hose under pressure, causing friction loss, which, in turn, decreases the amount of flow pressure at the nozzle. The friction loss is always less than the amount of pressure available at the source, whether a **pumper** or a hydrant,

**c.** When dealing with friction loss in hydraulics, the law of pressure may be expressed as follows -the water pressure at the source **minus** the pressure lost on the way equals the pressure at the nozzle. The pressure acquired in the beginning is the **engine pressure**. The pressure lost on the way is the **friction loss**. The pressure which is left is the **nozzle pressure**. The conclusion is that engine pressure minus friction loss equals nozzle

pressure ( $NP = EP - FL$ ), or, to put it another way, nozzle pressure plus friction loss equals engine pressure ( $EP = NP + FL$ ). These formulas are strictly rule of thumb; they are not the technical formulas.

#### 4-13. Ideal Requirements

Now the nozzle pressure necessary to make a good fire-extinguishing stream can be determined.

a. A good stream for structural firefighting is one which has enough pressure to reach the fire in a solid mass. This means that it must have ample range and must not break into large fog particles or water drops before reaching its desired range. This ideal structural **fire-extinguishing** stream must be capable of discharging  $9/10$  of its volume in a **15-inch** (38.1 centimeter) circle at a distance of **50** to 100 feet (15 to 30.5 meters), depending upon the size and extent of the fire. Experiments have revealed that 40 to 60 pounds (18 to 27 kilograms) of nozzle pressure will do this. The mean or average nozzle pressure would then be **50** pounds per square inch (22.7 kilograms per 6.46 square centimeters); this is the accepted pressure.

b. Since the desired nozzle pressure is known, the amount of friction loss in any given hose layout must be computed and added to the 50 pounds of nozzle pressure; the sum of these two figures would be equal to the desired engine pressure. Friction loss varies in proportion to the square of the degree of increase in the **flow** of water. Thus, when the flow of water through a hose is doubled, the friction loss increases four times. For example, if 200 gallons (757 liters) of water per minute are flowing through a hose with a friction loss of 20 pounds (9 kilograms), an increase to 400 gallons (1514 liters) per minute **would** bring the friction loss to **80** pounds (36 kilograms).

#### 4-14. Factors Affecting Friction loss

Friction loss also varies directly with the length of the line.

a. **This** means that the total friction loss will vary with each hose layout. For example, if there are 10 pounds (4.5 kilograms) of friction loss in 100 feet (30.6 meters) of **2½-inch** (6.35 centimeter) hose using a 1-inch (**2.54-centimeter**) nozzle, then there would be 20 pounds (9 kilograms) of friction loss in 200 feet (61 meters) of the same hose using the same nozzle.

b. Friction loss increases very rapidly with decrease in the size of the hose. If the diameter of

the hose is doubled, the friction loss is only **1/32 as much** as that in the smaller line. If the diameter is halved, the loss is 32 times greater than the larger line. Thus, friction loss in **1½-inch** (**3.8-centimeter**) hose is **13½** times as great as in **2½-inch** (**6.35-centimeter**) hose, other conditions remaining the same.

#### 4-15. Siamesing

When two hoses **run** parallel into a single hose to **which** one nozzle is attached, they are said to be siamesed.

a. This frequently done to prevent excessive loss and thereby increase nozzle pressure. Friction loss in two **2½-inch** (**6.35-centimeter**) siamesed lines of the same length is only 28 percent as great as in a single line of **2½-inch** (**6.35-centimeter**); 26 percent may be used for rapid calculation.

b. *For example*, if there are 10 pounds (4.6 kilograms) of friction loss in 100 feet (30.5 meters) of **2½-inch** (**6.35-centimeter**) hose, there would be **13½** times 10 (4.5 kilograms) or 135 pounds (61 kilograms) loss in the same length of **1½-inch** (**3.81-centimeter**) hose, other conditions remaining the same. In two lengths of **2½-inch** (**6.35-centimeter**) hose siamesed in parallel lines, there would be  $1/4$  of 10 (4.5 kilograms), or **2½** pounds (**1.134** kilograms) loss in discharging the same amount of water. This shows the value of a **siamese** connection, especially in the use of heavy streams where a large quantity of water is needed with greater pressure.

#### 4-16. Effect of Nozzle Size and Pressure

a. For all ordinary structural fires that have not advanced to the point of becoming an exterior conflagration, a 1-inch (**2.54-centimeter**) nozzle tip is used to keep water damage at a minimum while still having ample volume and pressure to extinguish the fire quickly and efficiently. A **1¼-inch** (**3.2-centimeter**) tip will discharge **1½** times as much water as a 1-inch (**2.54-centimeter**) tip, and a **2-inch** (**5.08-centimeter**) tip will discharge 4 times as much water as a 1-inch (**2.54-centimeter**) tip at the same nozzle pressure. The larger tips are used for large, advanced fires which require greater range and volume.

b. A 1-inch (**2.54-centimeter**) tip with **50** pounds (22.7 kilograms) of nozzle pressure will discharge slightly more than 200 gallons (767 liters) per minute with about 10 pounds (4.6 kilo-

grams) of friction loss for every 100 feet (30.5 kilometers) of **2½-inch (6.35-centimeter)** hose. So there will be a lo-pound (4.5 kilograms) pressure loss for each 100 feet (30.5 meters) of hose in use. Adding this friction loss to the desired nozzle pressure gives the engine pressure necessary to supply the nozzle pressure.

c. *For example*, in a 1,000-foot (**305-meter**) lay-out of **2½-inch (6.35-centimeter)** hose, using a 1-inch (**2.54-centimeter**) nozzle and desiring **50** pounds (22.7 kilograms) of nozzle pressure, the needed engine pressure is easily determined. Since there are ten **100-foot (30.5-meter)** sections in 1,000 feet (305 meters), with 10 pounds (4.5 kilograms) of pressure loss per 100 feet (30.5 meters) of hose, multiply the 10 sections by 10 pounds (4.5 kilograms) to get the pounds of friction (100) and add to it the 50 pounds (22.7 kilograms) of nozzle pressure required. This equals 150 pounds (68 kilograms) of engine pressure.

d. If the nozzle size is increased to **1⅞** inches (2.858 centimeters), maintaining 50 pounds (22.7 kilograms) of nozzle pressure, the flow of water increases to 265 gallons (1003 liters) per minute, with 18 pounds (8.165 kilograms) of friction loss for every 100 feet (30.5 meters) of **2½-inch (6.35-centimeter)** hose. If the nozzle diameter is increased to **1¼** inches (3.175 centimeters), the flow increases to 325 gallons (1230 liters) per minute, and the friction loss increases to 25 pounds (11.34 kilograms) for every 100 feet (30.5 meters) of **2½-inch (6.35-centimeter)** hose.

e. Friction loss for the five common nozzle sizes at 50 pounds (22.7 kilograms) of pressure is calculated in table 4-2. Every pump operator should memorize this table so that he can tell at once how much engine pressure is required for any type of layout that uses **2½-inch (6.35-centimeter)** hose.

f. When hose is laid or advanced to a level above the discharge outlet of the pump, the water in the hose exerts a pressure against the pump,

known as back pressure. This back pressure is determined by multiplying the height above the pump discharge outlet, in feet (0.305 meter), by 0.434, which is the pressure in pounds per square inch (6.45 square centimeters) created by 1 foot (0.305 meter) of water. In the army, each story of a building is considered as 12 feet (3.66 meters), so the back pressure for each story would be  $12 \times .434 = 5.208$  pounds (2.36 kilograms per 6.45 square centimeters), or approximately 5 psi (0.366 kilogram per square centimeter). *For example*, if the hose is advanced to the third story, which is two stories above the first,  $2 \times 5$  or **10** psi must be added to the pump pressure to compensate for the back pressure. The nozzle size that should be used is determined by the total length of a hose layout. In a short layout (up to 600 feet (183 meters) a 1x-inch (**3.175-centimeter**) tip may be used. In a medium layout, 600 to 900 feet (183 to 274.5 meters), a **1⅞-inch (2.86-centimeter)** tip is used. A long layout, 900 feet or over (274.5 meters), ordinarily requires the use of the 1-inch (**2.54-centimeter**) tip. The tip size, however, may be changed at the discretion of the senior firefighter.

g. To illustrate all the preceding points, set up a situation involving 700 feet (273.5 meters) of **2½-inch (6.35-centimeter)** hose. This is a medium layout, calling for the use of a **1⅞-inch (2.86-centimeter)** nozzle. From table 4-2 it is known that the friction loss factor of hose and nozzle is 18 pounds (8.2 kilograms) per 100 feet (30.5 meters). Seven multiplied by 18 equals 126 pounds (57 kilograms) of friction loss; to this add the 50 pounds (22.7 kilograms) of nozzle pressure required; the result is a required engine pressure of 176 pounds (80 kilograms). If the hose is taken up to the fourth floor, three floors above the first, multiply 3 by 5 (pounds) to get 15 pounds (6.8 kilograms) of back pressure. Then add this 15 to 176 to get 191 pounds (87 kilograms) as the total engine pressure required. For all practical purposes the answer 191 would be rounded off to 190, or the nearest figure divisible by 5.

h. One of the most important factors that determine success or failure in combating structural fires is the effectiveness of the fire stream. A weak stream generally will not reach the objective. Too much pressure will cause a stream to break up and lose its effectiveness. It has been determined that 50 psi (22.7 kilograms per 6.45 square centimeters) nozzle pressure will, in most cases, result in a good effective stream. If the chief or crew

Table 4-2. Friction Loss of Nozzles at 50 Pounds of Pressure

Nozzle size in inches	Approximate friction loss in pounds per 100 feet of 2½-inch hose
¾	4
⅞	8
1	10
1⅞	18
1¼	25

chief in charge decides that less or more pressure is needed, he will order or signal the pump operator to decrease or increase the pressure. The pump operator should, however, set the initial nozzle pressure at 50 psi.

i. The pump operator of a structural pumper must be thoroughly familiar with all the equipment on the truck. He must know how many lengths of hose there are in each layer in the hose bed. When hose has been laid from the truck, the operator should be able to determine how much hose was used in the lay by glancing at the hose remaining in the hose bed. (Only an approximate estimate is necessary.) The pump operator can, by glancing at the nozzle tips remaining on the truck, determine what size nozzle tip is to be used. Knowing the amount of hose laid and the size of the nozzle tip, the pump operator determines what pressure must be maintained at the pump to produce 50 psi at the nozzle by referring to the pump operator's guide plate (fig. 4-1).

**4-17. Pump Operator's Guide Plate**

Most structural pumpers employed by the army are equipped with a pump operator's guide plate installed on the left side of the pumper directly over or near the pump operator's controls.

a. This plate (fig. 4-1) lists the pump pressures required to maintain a desired nozzle pressure for different size nozzle tips and hose lengths and is used merely as a guide by pump operators.

b. To read the guide plate, a pump operator must understand what is meant by "changeover valve" and what occurs within the pump when the valve is placed in either of two positions.

c. He must understand that the only pumps equipped with a changeover valve are multiple-stage pumps. The Class 530B or 530C pumper,

SIZE OF NOZZLE	GPM	PRESSURE OF NOZZLE IN POUNDS	LENGTH OF 2 1/2 INCH HOSE LAYOUT											
			100	200	300	400	500	600	700	800	900	1000		
1"	209	50	62	73	84	95	106	117	128	139	150	160		
1 1/8"	266	50	69	86	103	120	137	154	171	188	205	222		
1 1/4"	326	50	78	103	128	155	178	203	228	253	278	303		

Figure 4-1. Pump operator's guide plate.

used by the army, have a single stage pump, however a two-stage pump is planned for the future. The two stage pump has two sets of impellers which operate from a single shaft. When the valve is placed in the "parallel" or "volume" position, the water entering the pump on the intake side is divided and delivered to both sets of impellers simultaneously. Then, as the impellers force the water out of each impeller housing, the two masses of water joins together before emerging from the discharge outlet. When the valve is placed in the "series" or "pressure" position, the water entering the intake side is delivered to one impeller, which forces the water through an outlet (orifice) to the other impeller which in turn forces it out at increased pressure through the discharge outlet,

d. The heavy zigzag line running down across the guide plate shows pressures required. This line divides the chart in half and is not to be considered when operating a single-stage pump. However, when operating a two-stage pump with a changeover valve and when pumping at a pressure listed to the left of the heavy line, be sure that the changeover valve is in the volume or parallel position. If pumping at a pressure listed to the right to the heavy line, see that the changeover valve is in the pressure or series position. Note that the pressures given in the chart are actual pressures, and that the pressure gages on various pumpers will vary in calibration. They may be calibrated in 2, 5, 10, or 50 psi. The policy is to set the pump pressure to the nearest calibration of the gage on that specific truck.

**Section III. HOSE, LADDER, AND PUMPER DRILLS**

**4-18. Introduction**

Hose,, ladder, and pumper drills performed under simulated fire conditions train firefighting personnel for an actual emergency.

a. The drills must be varied so that all the fire-protection equipment on the firefighting vehicle is used. These drills must be constantly practiced until the proficiency of both individual and crew in all the duties to be performed reaches a high level. After a high degree of skill is achieved, refresher drills must be carried out to retain it.

b. In the firefighting drills, each crewman has a series of assignments which must be quickly carried out in a precise manner and at the proper time. These assignments involve laying out the hose, putting the pump into operation, and erecting ladders on buildings. Since hesitancy on the part of a crewman could cause serious delay, and, in turn, serious fire damage and loss of life, these hose, ladder, and pumper operations must be understood and practiced until each man can execute them without a moment's hesitation.

c. It is difficult to specify a fixed procedure for drills, because of such variables as the aptitude of the crewmen, the frequency and intensity of training periods, and the conditions peculiar to each fire emergency and to each individual installation. Some general standards can be set up, however, although assignments will vary with each emergency.

#### 4-19. Special Purpose Rolls and Folds

When hose is used in a very **large** or high building, it is normally operated from a building **standpipe** system. This is a system of piping with outlets on each floor. A pumping engine should pump into this system to assure enough pressure for effective streams. As mentioned under the section on unlined fabric hose, the fire department advances its own hose from building standpipes. Where standpipe systems exist, hose should be carried that can be taken through **doors**, on elevators, and up stairways quickly. This hose **should** be compactly rolled or folded in such a way that it can be placed in service very quickly. Certain methods of rolling and folding hose are well suited for this use. Hose carried in these rolls and folds is also useful for extending lines or replacing burst lengths of hose. Often a carrying pack is employed which also contains wrenches, adapters to non-fire service threads on standpipes, and other tools.

a. **The Donut Roll.** The donut roll forms a compact roll with both couplings accessible. The hose will pay out quickly and easily, even with both couplings coupled, and does not kink. To form a donut roll lay the hose out flat (fig. 4-2), and pull the male coupling back so the hose is doubled back on itself, with the male coupling about 3 to 4 feet (approximately a meter) from the female. Stand at the folded end, and face the folded end with one foot on each side of the hose. Leave enough space in the fold to place one hand through the roll for carrying. Roll the doubled hose (fig. 4-2), keeping the top and bottom portions **alined** with your feet as you back up. When the roll is completed the male coupling should be a foot (0.3 meter) or so behind the female coupling, protected by the hose behind the female coupling. This protects threads from damage, or the nozzle if one is carried **preconnected**. If the roll is not exactly **alined** it can be flattened by laying it on the floor and stepping on it. If a second man is available to help in forming the donut roll, he can keep the hose **alined** and take up slack in the top

portion by pulling on the hose behind the male coupling. The first man would then face the coupling end to make the roll.

b. **The Double Donut Roll.** The double donut roll can be made up with two lengths of hose, and can also be used for a **single** length where carrying space makes a smaller but wider roll desirable. To roll a double donut with two lengths of hose (fig. 4-3), couple them together and lay the lengths flat, next to each other. Fold the loop that results at the coupled **couplings** back onto the **hose**. **Leaving** enough room for a hand hold, roll the hose toward the uncoupled couplings.

c. **Self Locking Start for Donut or Double Donut Roll.** The self locking start for donut rolls (fig. 4-3) will hold the roll in place when it is handled, and provides a **handle** for carrying. To form this feature the end fold or loop is brought out about 18 inches ( $\frac{1}{2}$  meter) on each side of the flat hose before the roll is started, folding it in once toward the couplings and laying it flat on the hose. When the roll is completed the loop left exposed on one **side** is passed through the other loop (fig. 4-4). By pulling on the hose that passes through the roll the second or locking loop is tightened. The roll can be carried by the first loop. To put the roll in service the loops are first disengaged.

d. **The Flat Single Length Fold.** A single length of hose can be folded compactly by laying the length flat (fig. 4-5), then bringing the couplings together on top of the hose and engaging them a few turns to insure they remain coupled. Fold the hose in from each end to within about a foot (0.3 meter) of the couplings, then fold one side over the other. Couplings are protected from damage. The hose can be carried easily and put in service quickly.

e. **The Standpipe Pack.** If a canvas, plastic, or leather bag is available, the hose can be accordion folded into it with couplings accessible. When the hose is coupled to the standpipe or the line to be extended, the line pays out from the bag (fig. 4-6). This bag can also serve to carry a spanner wrench and adapters for use if **standpipes** have non-fire service threads. A nozzle is usually carried connected to the line and often a gated wye is connected to the standpipe end of the hose. Hose appliances made of lightweight materials and hose of lightweight construction should be used for this purpose if available.



4-20. Hose loads

a. *Use of Standard Methods.* Hose carried on fire apparatus is loaded so that it can be put to use quickly and easily at the scene of a fire. It must pay out from the hose bed smoothly, without kinking. Standard methods of loading hose beds are used to assure that—

- (1) Hose will pay out easily, without binding.
- (2) Layers of hose will not settle into the

layers beneath, and become tangled.

(3) Hose will not be subjected to any more sharp bending than is necessary.

b. *Determining Which Standard Load to Use.* Several factors determine which of the standard loads should be used in a particular situation. The most important of these are—

- (1) The size and shape of the hose bed.
- (2) The amount of hose to be loaded.

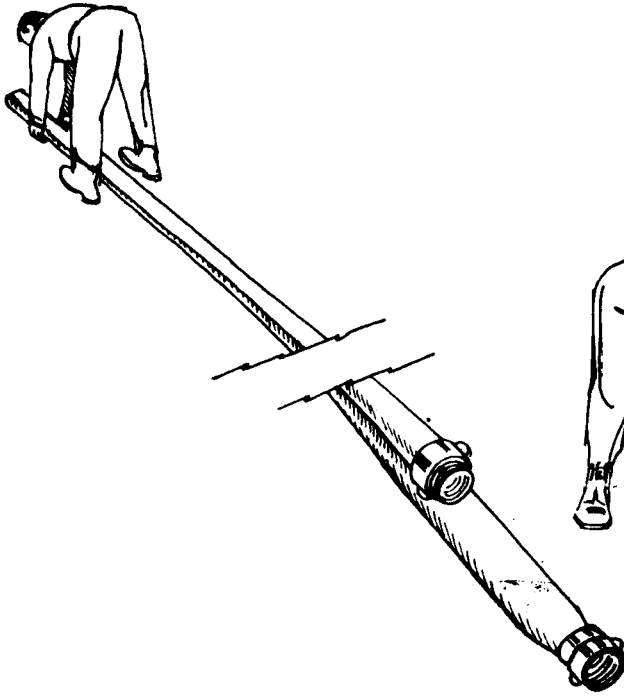

FORMING THE DONUT ROLL.



FORMING THE DONUT ROLL WITH TWO MEN.

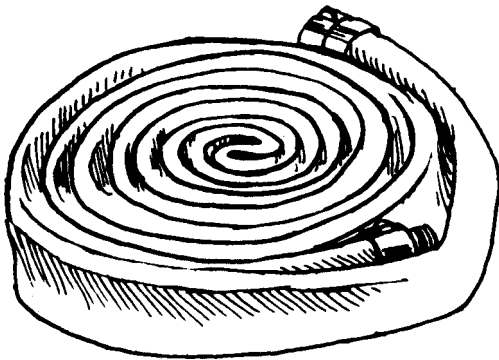

COMPLETED DONUT ROLL.

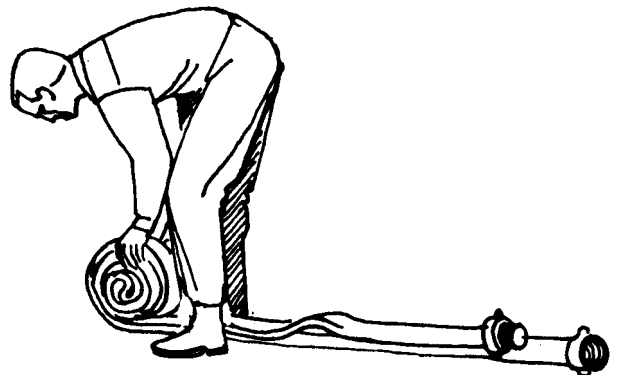

DONUT ROLL PARTLY COMPLETED.

Figure 4-2. The donut roll.

(3) The purpose for which the hose will normally be used.

(4) The water system or location of drafting sources in the area.

**4-21. Apparatus Hose Beds**

**a. Divided Bed.** Most hose carried on apparatus is loaded in a bed which is open to the rear of the

apparatus. To increase efficiency, beds are normally divided into two or **more** compartments (fig. 4-7), either by built-in partitions or by placing boards (baffle boards) in the bed as hose is loaded. Separate compartments are provided for **2½-inch (6.35centimeter)** and **1x-inch (3.81-centimeter)** hose (fig. 4-8). The term **divided load** is used to describe a load in which the larger size hose, **2½-inch (6.35-centimeter)**, **3-inch (7.62-centimeter)** or larger, is divided so that two or more lines can be laid with a single movement of the apparatus. This is an advantage when the quantity of water to be moved is too great for a single line.

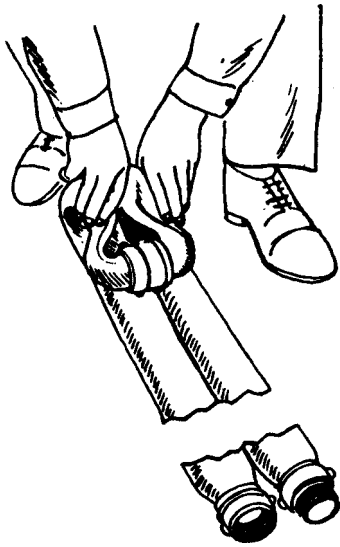

**BEGINNING** THE DOUBLE DONUT ROLL.

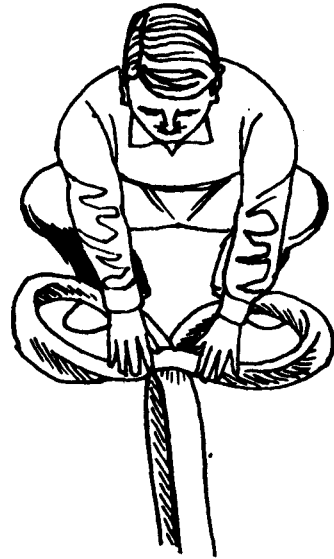

FORMING THE **SELF** LOCKING START FOR A DONUT ROLL.



COMPLETED DOUBLE DONUT ROLL.

*Figure 4-3. The double donut roll.*



COMPLETED DONUT ROLL WITH SELF LOCKING LOOPS.

*Figure 4-4. Self locking donut roll.*

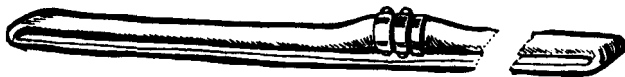

BEGINNING THE SINGLE LENGTH FOLD.



SECOND STEP IN FORMING A SINGLE LENGTH FOLD.



COMPLETED SINGLE LENGTH FOLD.

*Figure 4-5. The single length fold.*

**b. Cross Body or Transverse Hose Beds.** These beds are provided on some apparatus for attack lines, which can be taken off to either side. They are usually located behind the cab and can be reached quickly by men riding in or behind the cab. The lines are usually connected to a swivel fitting in the middle of the bed, which connects to piping from the pump. This allows the line to be taken from the side of the apparatus directly toward the fire, if there is room for both the engine and a ladder truck in front of the building on fire. Disadvantages of cross body hose beds include interference with the pump operator's use of the pump panel, and the short length of the bed, which is less than the width of the apparatus. Hose loaded in such beds has more sharp bends than where a longer bed is used.

#### 4-22. Functions of Hose lines

The function—or purpose for which normally used—of a hose line determines how it is loaded and what type of hose is used. Lines that are

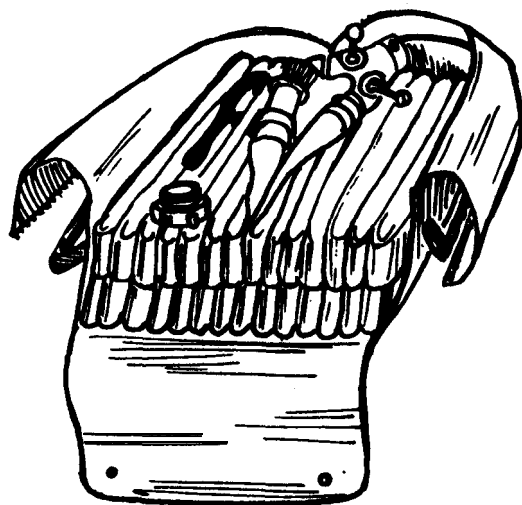
*Figure 4-6. The standpipe pack.*

normally used for supplying water to pumping engines, building sprinkler systems, or nozzles and master stream devices at major fires must be large enough to move large volumes of water efficiently. They should be capable of being laid by movement of the apparatus. **Preconnected 1½-inch (3.81-centimeter) or 2½-inch (6.35-centimeter) attack lines**, with nozzles attached and connected to piping from the pump, are designed to be put in operation quickly with the apparatus placed near the involved building. They are stretched by hand.

#### 4-23. Standard Loads

The methods used by fire departments for loading hose on main hose beds of a fire truck are the accordion load, the flat load, and the horseshoe load. These loads can be packed tight enough by hand to keep the layers from settling into each other as apparatus travels over the road. Tools such as bars and spanners should never be used to pack hose. This could result in damaging the hose, and in loads too tight to pay out easily. When loading hose it is important to locate couplings so they will pay out without turning in the bed. Turning couplings can wedge in the bed and may also fly up and injure men on the back step. To locate couplings properly, it is sometimes necessary to use a short fold when loading the bed. This is called a **dutchman**. The method for forming a **dutchman** is described under each of the standard loads. In beginning a load the coupling that is loaded first—and will be the last off—is placed at the rear corner of the bed so it can be seen when the load is completed. When a divided bed is used it is possible to connect the top cou-

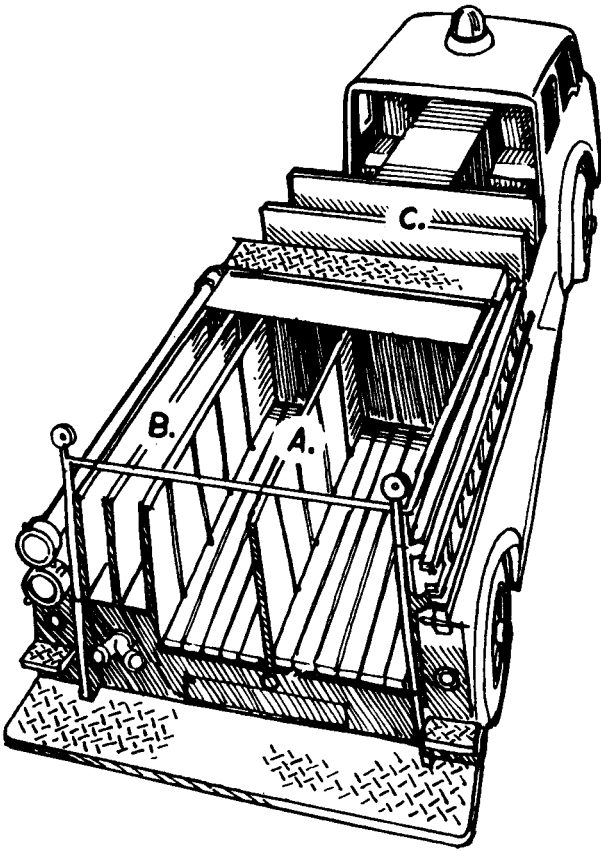

**A, DIVIDED MAIN BED**  
**B, BEDS FOR PRECONNECTED HOSE**  
**C, CROSSBODY OR TRANSVERSE REDS**

Figure 4-7. Hose beds.

pling in one bed with the bottom coupling in the next, so that a single long line can be laid without stopping. If the hose is not crossconnected, the visible coupling will show at a glance that the hose is not preconnected. In describing the various loads, the *front* of the hose bed is the end toward the apparatus cab, and the *back* or rear the end at the back step.

a. **The Accordion Load.** The accordion load consists of folding the hose back and forth lengthwise in the bed accordion fashion, with the hose on edge. The main advantage of this load is the ease with which shoulder loads can be formed for hand stretching lines. Its principal disadvantage is that it places many sharp bends in the hose.

(1) To form an accordion load, place the first coupling in the rear of the bed, next to the partition or baffle board that will separate the two parts of the main hose load (fig. 4-9). Take the hose to the front of the bed, standing on edge, fold 180°, and bring it to the rear alongside the first fold. Again fold 180 degrees and repeat the proc-

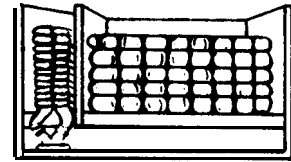

END VIEW

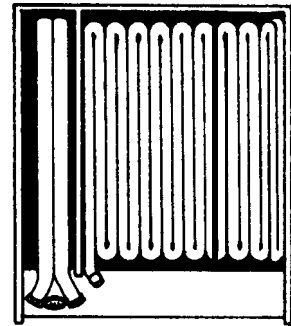

TOP VIEW

Figure 4-8. Divided bed.

ess. As each end fold is formed, stagger alternate folds with the first all the way to the end of the bed, and the next 2 or 3 inches (5 to 8 centimeters) short of the end. This keeps folds from coming directly opposite each other, which would make the ends fill up faster than the middle of the bed and would also make the folds sharper.

(2) To change the position of a coupling with a dutchman, take a short fold in the hose (fig. 4-10). This assures that the coupling will not turn in the truck bed when paying out.

(3) When a layer is complete, the last 180° fold at the rear of the hose bed is made in the opposite direction of the other folds (fig. 4-11). This prevents kinking when the hose is laid. The hose is then tucked between the two previous folds and taken to the front of the bed, rising gradually to the top of the first layer at the front of the bed. It is then either brought straight back, beginning the next layer, or carried across the front of the bed to begin the second layer on the same side as the first.

b. **The Flat Load.** The flat load consists of folding the hose back and forth lengthwise in the bed, with the hose flattened (fig. 4-12). It pays out very easily and produces a straighter lay than the accordion load. However, it is more difficult to form shoulder loads for hand stretching from the flat load than from the accordion load. Both loads have many sharp bends in the hose.

(1) To form a flat load, place the first coupling in the rear corner of the bed next to the partition or baffle board that separates the two parts of the main hose load (fig. 4-12). Lay the

hose to the front of the bed, fold it 180 degrees, and bring it to the rear at a slight diagonal to place the second fold next to the first coupling. Fold 180 degrees and repeat the process. Keep the end folds even.

(2) To change the position of a coupling, make a short fold (dutchman) as with the **accor-**

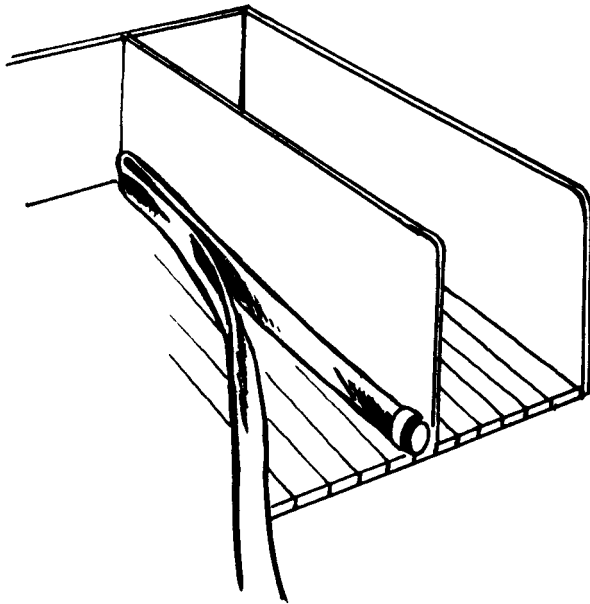

BEGINNING THE ACCORDION LOAD

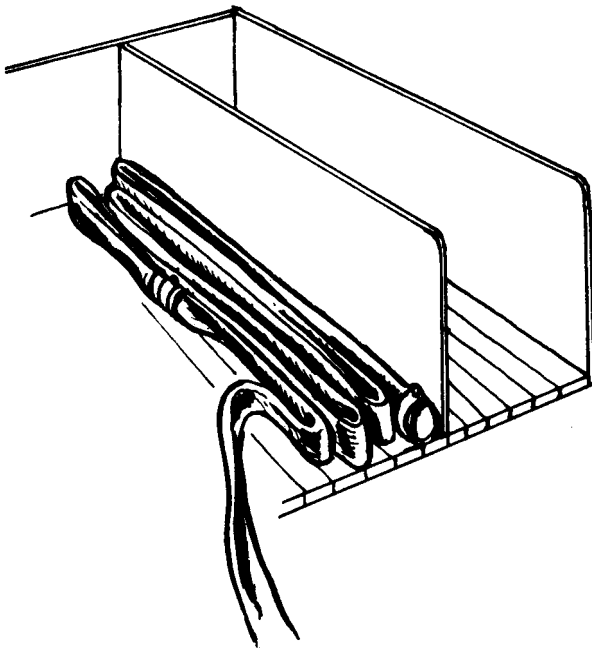

FORMING THE ACCORDION LOAD NOTE STAGGERED FOLDS.

Figure 4-9. *The accordion load.*

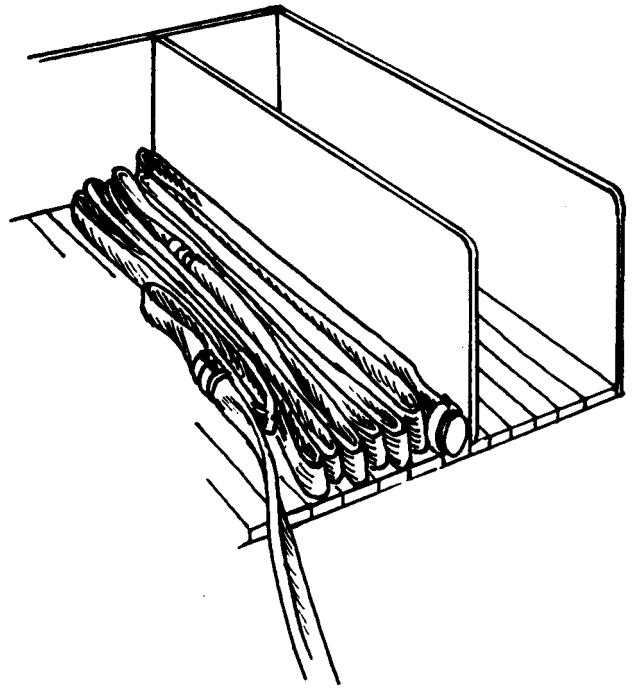

Figure 4-10. *Forming a dutchman.*

dion load, except that the fold will be doubled back on itself rather than placed next to itself (fig. 4-12).

(3) When the first layer is complete, begin the second by laying the hose diagonally in the opposite direction (fig. 4-12). The layers are formed in the same manner as the first layer, except that in alternate layers the **end** folds at each end are staggered by 2 or 3 inches (5 to 8 centimeters) so that the bends will be less sharp and the ends will not fill up faster than the middle of the bed.

c. **The Horseshoe Load.** The horseshoe load consists of hose loaded around the sides and front of the **bed** so that its shape roughly **resembles** that of a horseshoe. It has the advantage of less sharp bends in the hose, but does not lend itself readily to forming shoulder loads for hand stretching.

(1) To form the horseshoe load, place the first coupling next to the partition or baffle board that separates the two parts of the main hose load (fig. 4-13). Lay the hose to the front of the bed with the hose lying on edge, fold the hose 90 **de-**grees, **and** lay it across the front of the bed to the opposite side. Make a 90° fold and lay the hose to the rear of the bed. Then fold it 180 degrees **and** repeat the process. Stagger the 180 degree folds at the rear of the bed as shown in figure 4-13.

(2) Coupling positions can be changed by use of a short fold (dutchman) as **with** the accordion

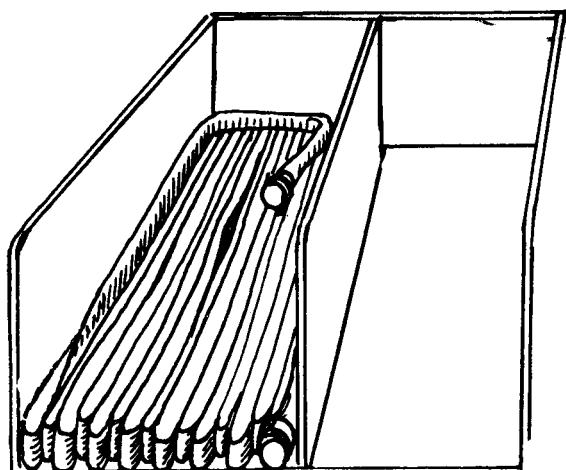
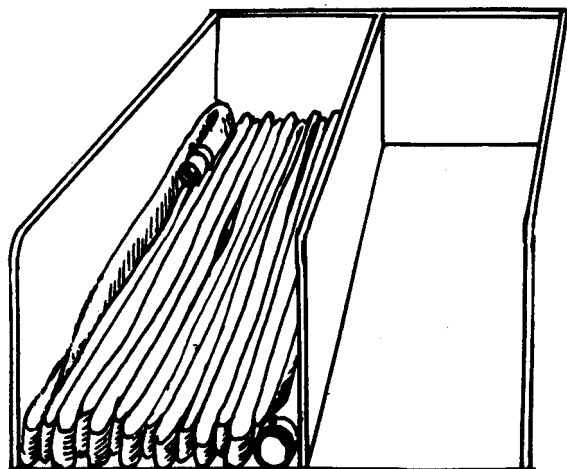

Figure 4-11. Two methods of starting second layer of accordion load.

load or by taking an extra fold across the front of the bed (fig. 4-14).

(3) A new layer is started by bringing the hose to the rear of the bed (fig. 4-15), across the end of half of the layer, and then gradually rising as it is being brought to the front of the bed. An alternate method (fig. 4-15) may be used in which the last fold of the layer toward the front of the bed is brought up, laid flat, and placed diagonally to a front corner. Then the hose is folded to bring it up on edge and laid in the same way as the layer laid previously.

#### 4-24. Hose load Finishes

Hose load finishes have two primary purposes—to provide hose line at the fire area with a minimum amount of effort and for convenience in hooking up to a hydrant. The finishes must provide a loosely loaded hose that will pull off the truck and

pay out easily. The method adopted is governed by the local conditions and the preferences of the fire chief.

*a. The Donut Finish.* The donut roll, described in paragraph 4-19a, can be used to finish a hose load (fig. 4-16). It provides 50 feet (15 meters) of hose to facilitate hooking up to a hydrant or advancing attack lines. When a load is finished with a donut roll a second length of hose is usually placed (flaked) loosely back and forth across the top of the load so the donut can be carried off easily.

*b. Cross Fold or Riprap Finish.* This finish consists of loading the last length or two in a loose accordion fashion across the hose bed on top of the load (fig. 4-17). It will pay out freely, and a bundle can be grasped under the arm when stepping off to catch a hydrant.

*c. Skid Load Finish.* The skid load is used to finish a load for working attack lines when the reverse lay is employed. About 15 feet (4.5 meters) of hose is loaded starting at the front of the bed with a cross fold (fig. 4-18). The hose is then turned flat and brought to the rear of the bed about 12 to 18 inches (30.6 to 46 centimeters) from the side of the bed. It is allowed to hang over the rear edge of the load about a foot (30.6 centimeters) 180°, and taken back on itself to the front of the bed. Here it is folded to run at a right angle to a point the same distance from the opposite end of the load, folded again, and brought to the rear and back to form a second skid (fig. 4-18). At the front of the bed the hose is brought up on edge and loaded in a cross fold on the two skids (fig. 4-18). The ends of the cross fold are kept 3 to 6 inches (7.6 to 15 centimeters) from the sides of the hose bed so the load will not dislodge when laying out. A nozzle can be attached and placed on top of the cross folds (fig. 4-18). A 2½-inch (6.35-centimeter) by 1½-inch (3.81-centimeter) reducing wye can be coupled to the 2½-inch (6.35-centimeter) hose and a line of 1½-inch (3.81 centimeter) hose, or two lines folded together, used to complete the skid load. Care must be taken that all couplings and appliances used in the skid load rest on the skids or on top of the cross fold position.

#### 4-25. Inspection and Maintenance

All hose and fittings should be inspected monthly, and after each use they should be washed and inspected again.

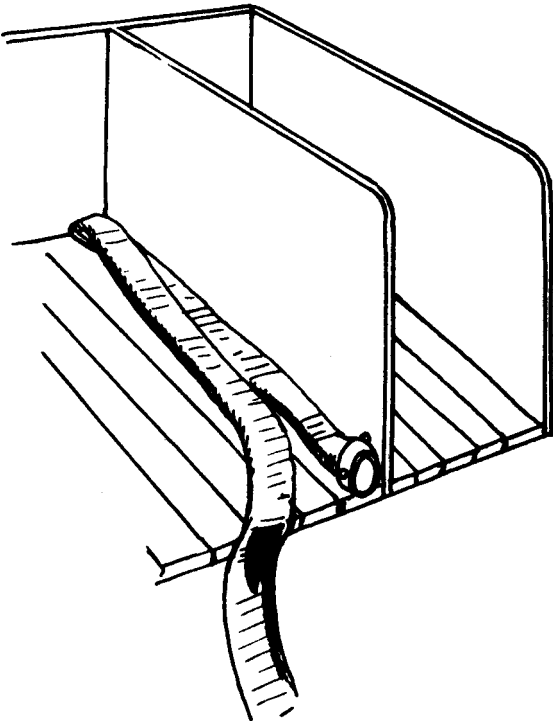

BEGINNING THE FLAT LOAD

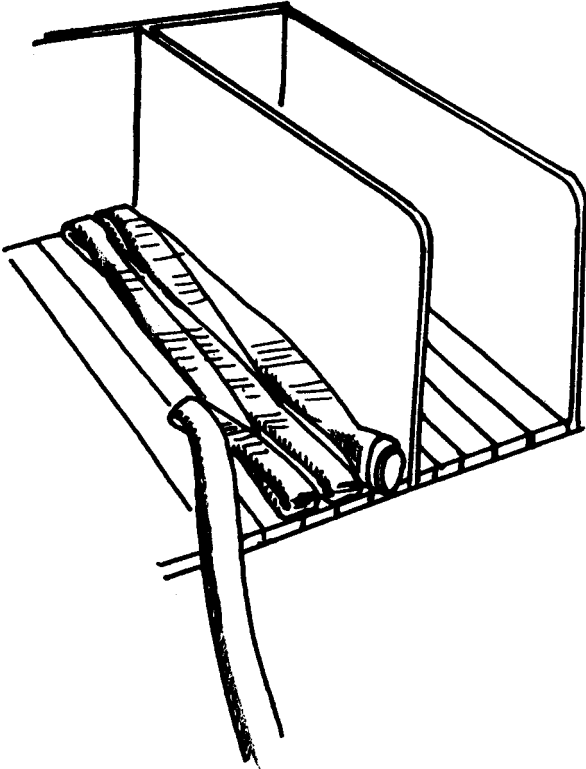

FORMING THE FLAT LOAD

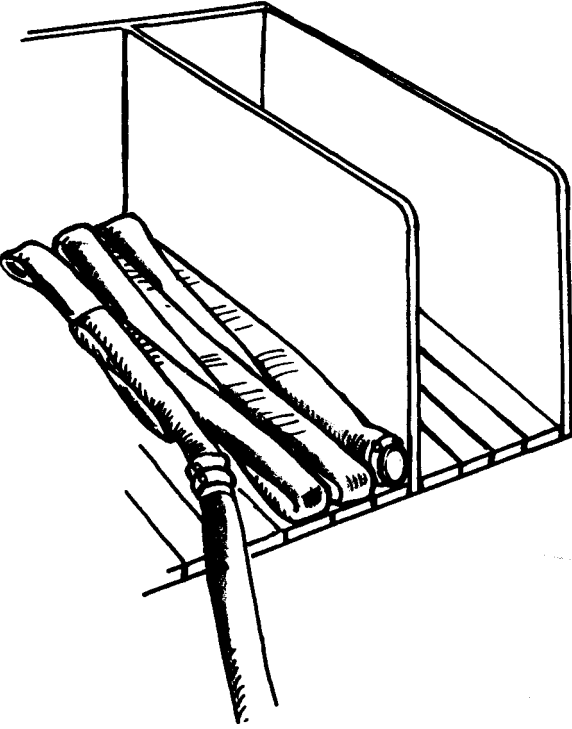

BY FOLDING THE HOSE BACK ON ITSELF

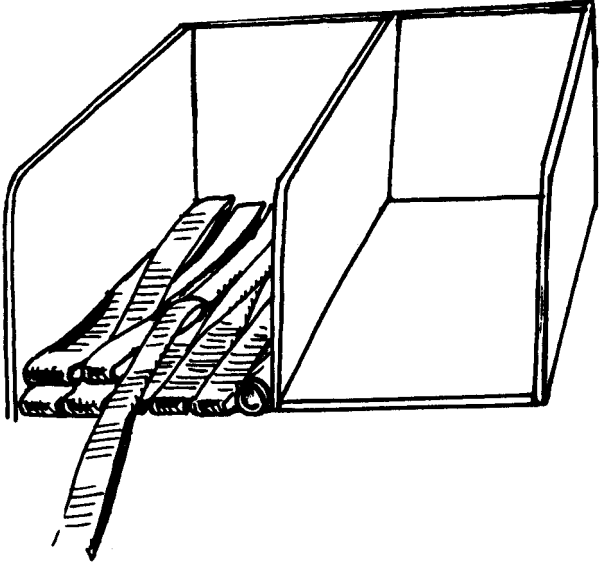

THE SECOND LAYER NOTE THAT FOLDS ARE STAGGERED FROM THOSE IN FIRST LAYER

Figure 4-12. The flat load.

a. When inspecting hose, go over the jacket thoroughly for breaks or worn spots. Look closely where the hose enters the coupling to see if there is any sign of the coupling coming loose. Look inside the coupling for damaged or slipping expansion rings. Inspect the swivel of the female couplings for damage.

b. Any damage to hose should be reported immediately to the crew chief in charge and recorded on the hose record card. The threads of couplings should be cleaned thoroughly with a wire brush and a small amount of powdered

graphite or mild soap solution should be applied to them.

4-26. Hose **layouts and Carries**

The preceding paragraphs covered the various methods of loading hose on a firetruck. Additional preparation is that of hose layouts and advancement to fires. Time is not so important when loading hose, but the process requires the utmost skill and cooperation because it is an important factor in hose layouts. There are only two hose layouts used in the Army: the *straight* lay and the reverse lay (which is the standard Army hose lay),

a. *Straight Lay.* The straight lay (fig. 4-19) is made as follows: On the approach to a fire the truck stops at a hydrant chosen by the crew chief. The hydrant should be as near the fire as possible without endangering the truck or driver, should the fire spread. The **plugman** steps off with enough line, and while he takes a turn around the hydrant with the hose, the truck proceeds to the fire. The

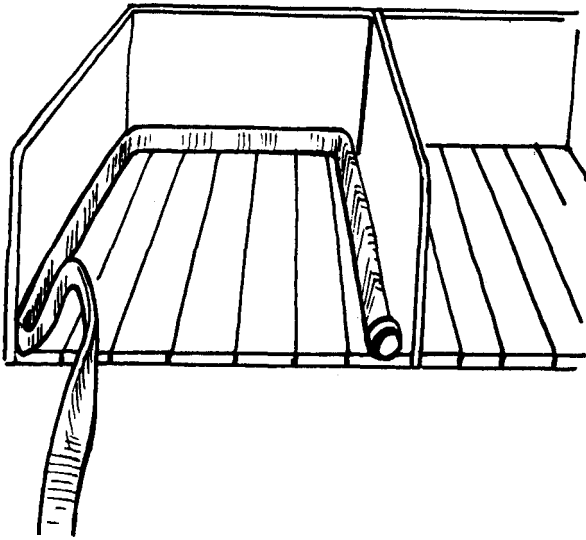

BEGINNING THE HORSESHOE LOAD.

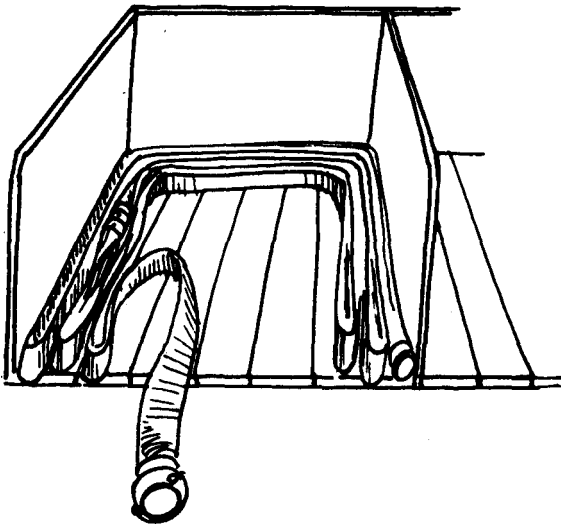

FORMING THE HORSESHOE LOAD.

**NOTE** STAGGERED FOLDS.

Figure 4-13. The horseshoe load.

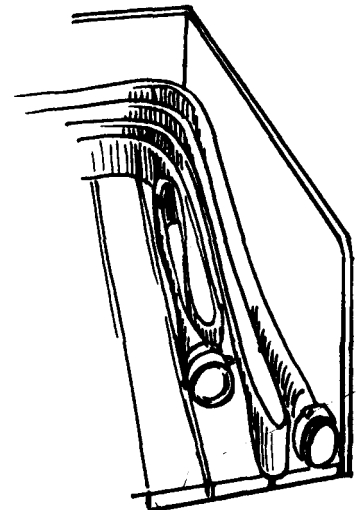
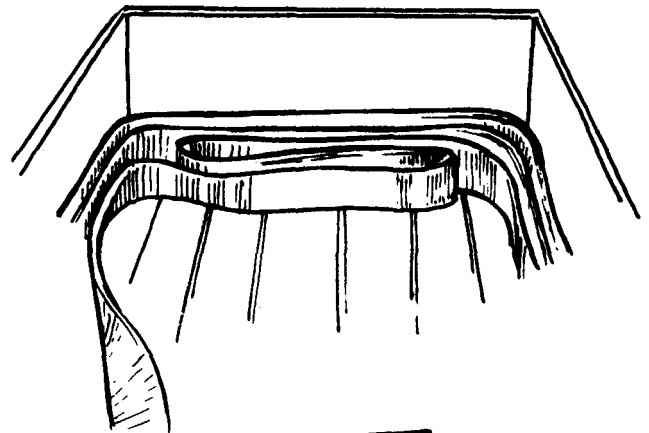
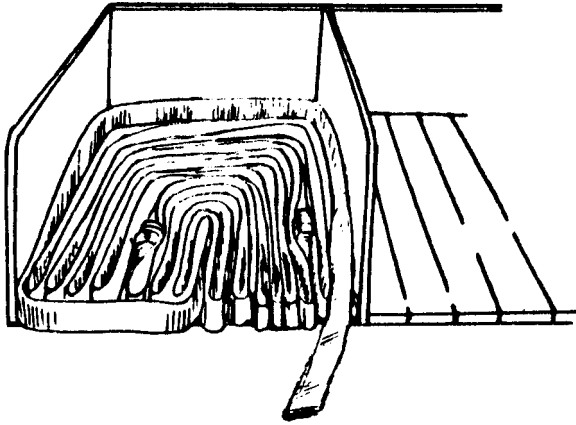
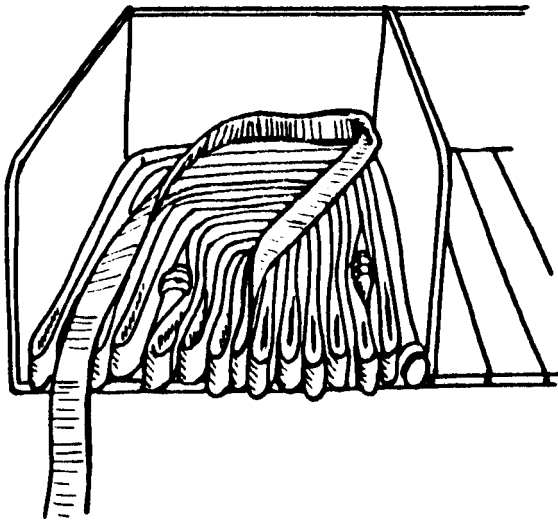

Figure 4-14. Two methods of forming a dutchman with the horseshoe load.





STARTING A SECOND LAYER OF THE HORSESHOE LOAD.



ALTERNATE METHOD OF STARTING A SECOND LAYER.

Figure 4-15. Second layer of horseshoe load.

plugman removes the 2½-inch (6.35centimeter) cap nearest the fire, connects the hose, removes the loop that is around the hydrant, opens the hydrant with his hydrant wrench, and proceeds to the fire, straightening out kinks or bends in the hose on the way. When the truck arrives at the fire, a hose clamp is applied to the hose, and enough working line (determined by the crew chief) is removed from the truck by a hoseman, who grasps one or more folds and walks backward till the loop or loops are clear of the truck. Then he goes back to the truck and repeats the procedure. He lays each loop nearer the fire. When enough hose has been removed, he disconnects the nearest coupling, puts the loose end back in the truck bed, and connects the nozzle to the hose. He then removes the hose clamp from the hose. He can then advance to the fire.

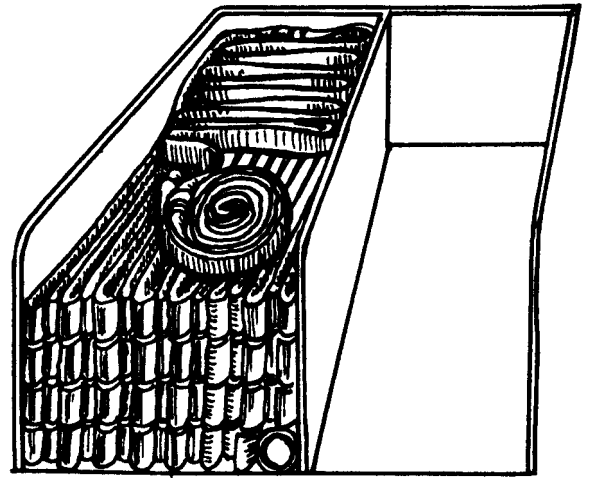

Figure 4-16. Donut roll finish for hose load.

NOTE

It is a good practice for the driver, if possible, to stop the truck about 75 to 100 feet (23 to 30.5 meters) beyond the nearest point to the fire. This will give the hoseman that much additional working line.

The straight lay, particularly if a long 2½-inch (6.35-centimeter) supply hose line is used, car supply only 1½-inch (3.81-centimeter) hose line: and the pumper can be used only to a fraction of its capacity. The straight lay should be used with caution and only for a 1½-inch (3.81-centimeter) hose stream fire without possibility of development into a 2½-inch (6.35-centimeter) hose stream fire. The straight lay may be used under certain circumstances if a second pumper is positioned at the hydrant.

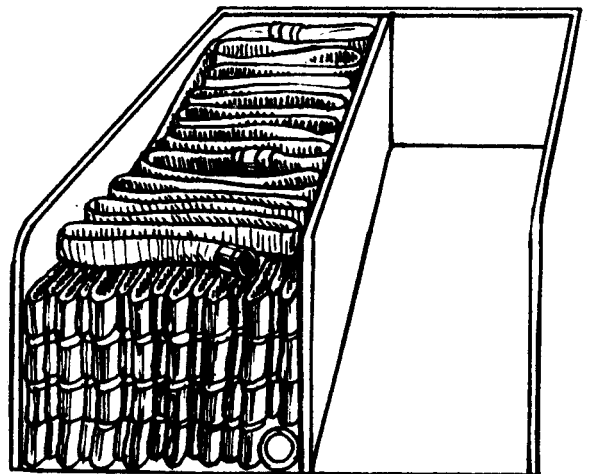
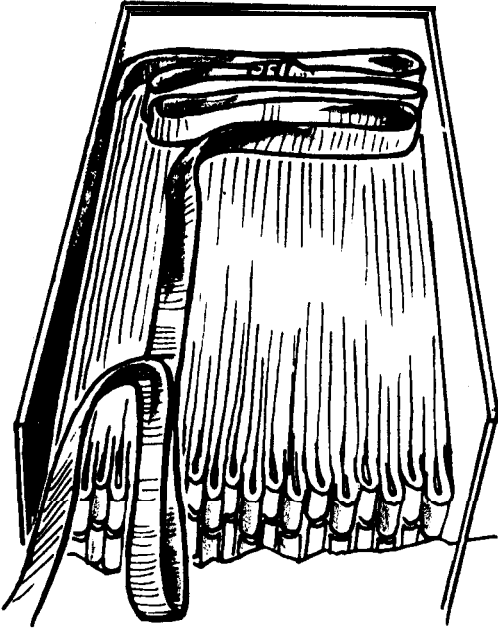
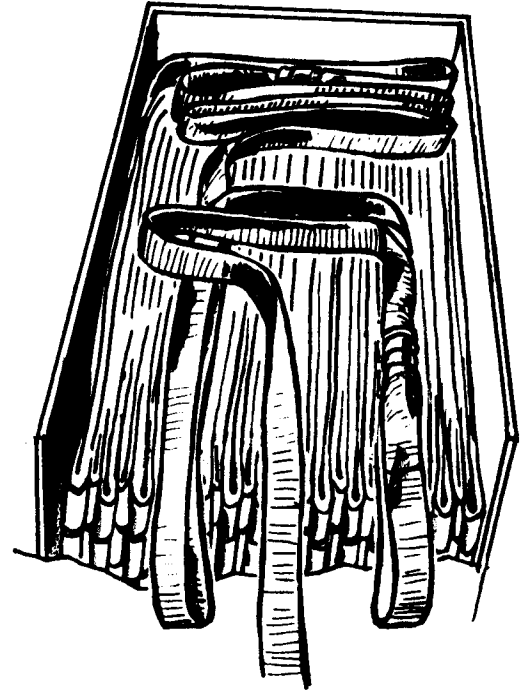

Figure 4-17. Cross fold finish for hose load.



BEGINNING THE SKID LOAD FINISH.



FORMING THE CROSS FOLD PORTION OF THE SKID LOAD FINISH.

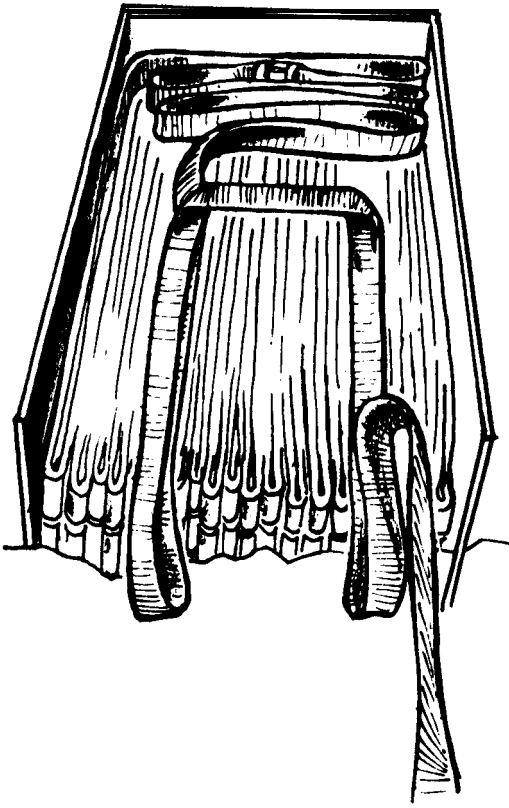

FORMING THE SECOND SKID.

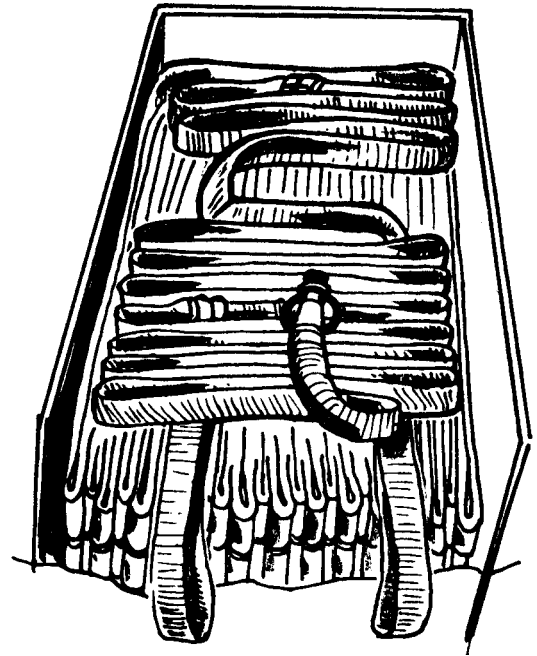

COMPLETED SKID LOAD FINISH FOR HOSE LOAD.

Figure 4-18. Skid load finish.

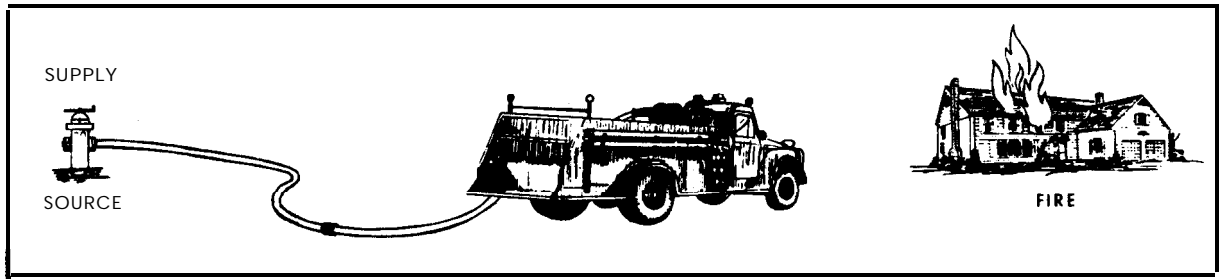

Figure 4-19. Straight lay.

b. **Reverse Lay.** When using the reverse lay, the hosemen lay hose from the fire to the hydrant (fig. 4-20).

(1) The pumper can be used to capacity and 2½-inch (6.35centimeter) hand lines used only when the pumper is positioned at the hydrant and taking suction through a 4½-inch (11.43-centimeter) hose.

(2) To make the reverse lay, the following procedures should be used. The truck should stop 75 to 100 feet (23 to 30.5 meters) short of the nearest point to the fire. (This will give additional working line.) The hosemen remove the working line by pulling a “skid” or other hose load. When the working line is removed, the nozzle men start advancing the line to the fire. While the nozzle men are occupied, the crew chief, driver, and plugman remove other equipment that may be needed, such as ladders (extension and roof), forcible-entry tools, portable lights, and pike pole. This equipment should be placed off the road and on the fire side of the truck. The crew chief kneels on the hose line to anchor it as it pays out, and then proceeds to the fire to aid and supervise the nozzle men.

NOTE

This procedure is flexible. The crew chief may have one of the hosemen anchor the hoseline while he proceeds to the fire.

The driver and plugman remount the truck, the plugman riding on the side to avoid injury from hose and couplings as the load is paying out. Making sure that a crew member is anchoring the hose, the driver drives the truck to the hydrant. He then puts the pump in gear, dismounts, disconnects the hose at a coupling (making sure there is enough hose to reach the pump), returns the loose end of the hose to the hose bed, carries the end of the hose that leads to the fire around to the pump on the side opposite the hydrant, and connects the hose to the discharge outlet of the pump. He may, if necessary, assist the driver in connecting the suction hose to the hydrant. The hydrant valve is then opened. The plugman proceeds to the fire, checking the hose line for leaking couplings and kinks, and reports to the crew chief. The driver remains at the pump controls at all times while the pump is being used.

c. **General Principles of Layout.** Any crew making a layout during drill or actual emergency must understand the principles of fire hydraulics in order to compute such things as friction loss. Hose layouts, such as siamese operations, may be carried out during drill periods, depending upon the potential firefighting demands of the individual base. In areas where the possibility of extensive fires exists, it may be well to concentrate on drills containing layouts where large water volumes and pressures may be required. It may be advisable under these conditions to establish a

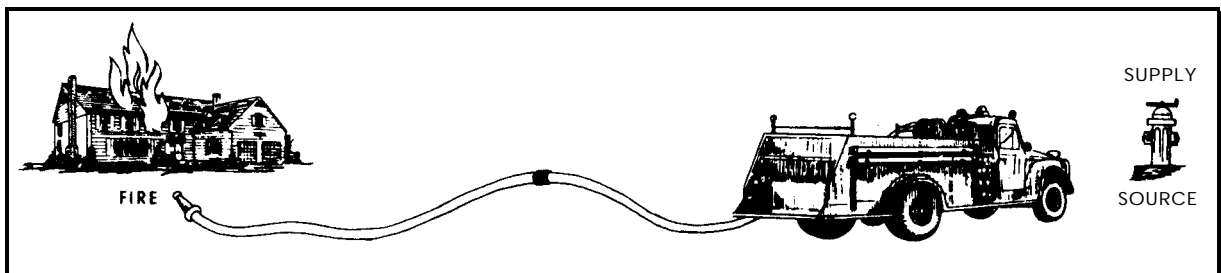

Figure 4-20. Reverse lay.

preassigned procedure for each piece of apparatus where the fire hazard exists. The pieces of apparatus which would normally be first in, or first to arrive at the scene of a potential fire, should be given priority.

**d. Advancing the Lines.** The most commonly used method of advancing the line is as follows :

(1) The nozzleman faces away from the fire, puts the hose over his left shoulder with the nozzle hanging downward at his back, and turns to the left facing the fire; the hose will extend across his chest and in under his right arm (fig. 4-21). He then advances to the fire.

(2) Personnel to the rear of the nozzleman carry the hose by means of the shoulder carry and the underarm carry (figs. 4-22 and 4-23). When using the shoulder carry, the carriers must place the hose on the same shoulder as the nozzleman uses. The underarm carry is particularly good for advancing lines at street level. Underarm loads may be picked up easily and quickly.

**e. Advancing Hose up a Ladder.** A 2½-inch (6.35-centimeter) hose should always be advanced up a ladder with a dry line if possible.

(1) A hose full of water is difficult to move or maneuver. If the line is already charged, time and effort are saved if the line is first broken and drained before any extensive advancement is attempted.



Figure 4-21. Carrying a hose forward.



Figure 4-22. Shoulder carry.

(2) In advancing an empty line up a ladder, the men climb about 10 to 12 feet (3 to 3.7 meters), with the hose on their shoulders and 20 to 25 feet (6 to 7.6 meters) between them (fig. 4-24). As the operation progresses, additional hose must be fed or passed to the men on the ladder to prevent the line from becoming fouled. When enough hose for adequate maneuvering has reached the desired height, the hose line should be anchored with a rope hose tool, chain, or strap to a fire well, a window sill or the ladder itself. The anchor should be made directly below the coupling to remove the strain of the hose and water weight from the lineman.

**f. Advancing Hose Up A Stairway.** Hose is difficult to drag even in an open, unobstructed area, and it is very difficult to maneuver around obstructions, such as those offered by a stairway. Time and energy may be saved if the hose is carried. The underarm carry is superior for stairway work under most conditions (fig. 4-25). If the hose has been properly removed from the apparatus, a man can quickly grasp an armful, since it lies in an orderly position. Again, advancing the hose is much faster and easier if the line is kept dry until the fire is approached; this can be done by keeping the hose clamp in place until the proper time for its release.



Figure 4-23. Underarm. carry.

g. *Advancing Hose With a Handline.* It frequently becomes necessary to take a hose line to an upper window or over a roof parapet with a handline. The line should be dropped from above by someone who has already carried the coiled handline to the desired level. Hose lines should be hoisted dry whenever possible, even if this requires draining a line. It is usually faster to do this than to attempt to hoist a charged line. In hoisting the line, it is doubled back so that the nozzle is about 4 feet (1.22 meters) from the end (fig. 4-26). A clove hitch is tied around the nozzle and hose, securing the nozzle a few inches behind the tip, with the standing end of the rope on the opposite side of the doubled hose from the nozzle (1). Next a half hitch is taken around the hose about a foot from the end (2). As the hose is hoisted, the standing end of the rope is kept between the building and the hose if possible, to prevent unnecessary damage to the hose. A man on the ground guiding the hose can assist in maintaining this position.

#### 4-27. Replacing a Section of Hose

A hose line does not normally burst when equipment is properly handled, maintained, and inspected. Nevertheless, it happens, and any fire organization will suffer serious consequences if

drills and precautions against burst lines are not undertaken. If a hose bursts, either the ruptured section of hose must be replaced, or a short line must be extended; either procedure requires shutting down the line by kinking it (fig. 4-27) or by using a hose clamp. The hose clamp is normally used if it is immediately available; if not, the line may be kinked behind the coupling to save the time required to go back to the hydrant. The replacement section is brought to the point where it is to be inserted, care being taken that the couplings are not dragged, dropped, or damaged in moving and that the male and female coupling are placed to make proper connection. Manpower permitting, the ruptured section should be removed while the replacement section is being carried from the apparatus. To save time, both connections should be made simultaneously.

#### 4-28. lengthening a Hose

Every precaution must be taken to provide enough hose for whatever maneuvering may be required to reach any portion of the structure involved in fire or any nearby structures which may be ignited by the original fire. Frequently, 1½-inch (3.81 centimeter) lines are fed by a 2½-inch (6.35-centimeter) line for confined spaces and for overhaul purposes. This requires that the

larger line be advanced when necessary and demands surplus or additional lines. When a line must be lengthened, two men remove two lengths (or 100 feet (30.6 meters) of hose) from the truck, and, using the shoulder carry, proceed to the end of the line (fig. 4-28). When the second man is about 25 feet (7.6 meters) beyond the end



Figure 4-24. Advancing a hose up a ladder.



Figure 4-25. Advancing a hose up a stairway.

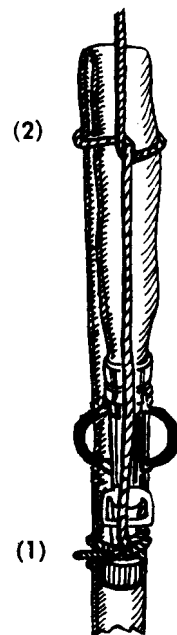

DRY LINE

Figure 4-26. Hoisting hose with a handline.

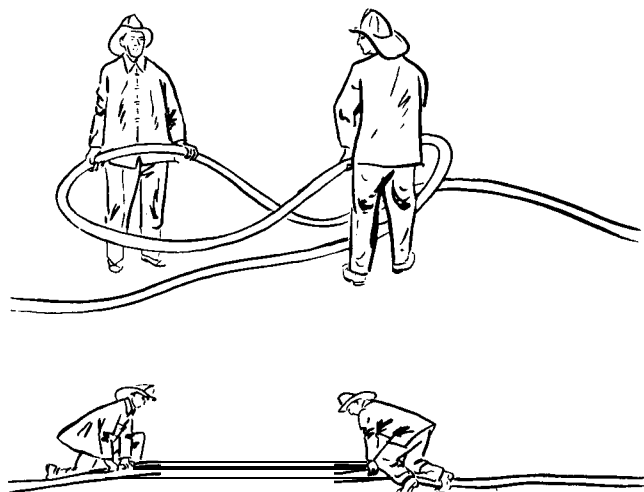

Figure 4-27. Kinking a hose line to stop flow.

of the line to be lengthened, he drops the hose, lays the coupling on the ground, and goes back to make the connection. The line is coupled while the first man continues on, paying off hose from his shoulder. After completion of the connection, water is readmitted into the hose when the signal is given.

#### 4-29. Controlling a Charged line

Working on a ladder sets up unstable conditions especially when a charged hose line is being handled. To prevent accidents and conserve efforts,

the hose may be anchored to the ladder with either a hose rope, a hose strap, or a hose chain (fig. 4-29).

a. As previously stated, it is difficult for one man to hold a nozzle of normal size which is discharging water from a  $2\frac{1}{2}$ -inch (6.35-centimeters) line. This feat becomes even more difficult on a ladder. Therefore, when water is being discharged from a nozzle while the nozzleman is standing on a ladder, the hose should be secured to the ladder a few feet behind the nozzle, or within the small-

est distance necessary to permit proper movement of the stream. Securing the hose in this way stops the nozzle reaction or kickback.

b. Frequently, when a nozzle is operated from ground level, not enough manpower is available, or too much nozzle pressure causes the nozzle to set up too much reaction to allow its safe holding. This situation may be remedied to a reasonable extent by shutting off the nozzle, looping the hose, and tying it to the forward end of the loop just far enough behind the nozzle to allow maneuvera-

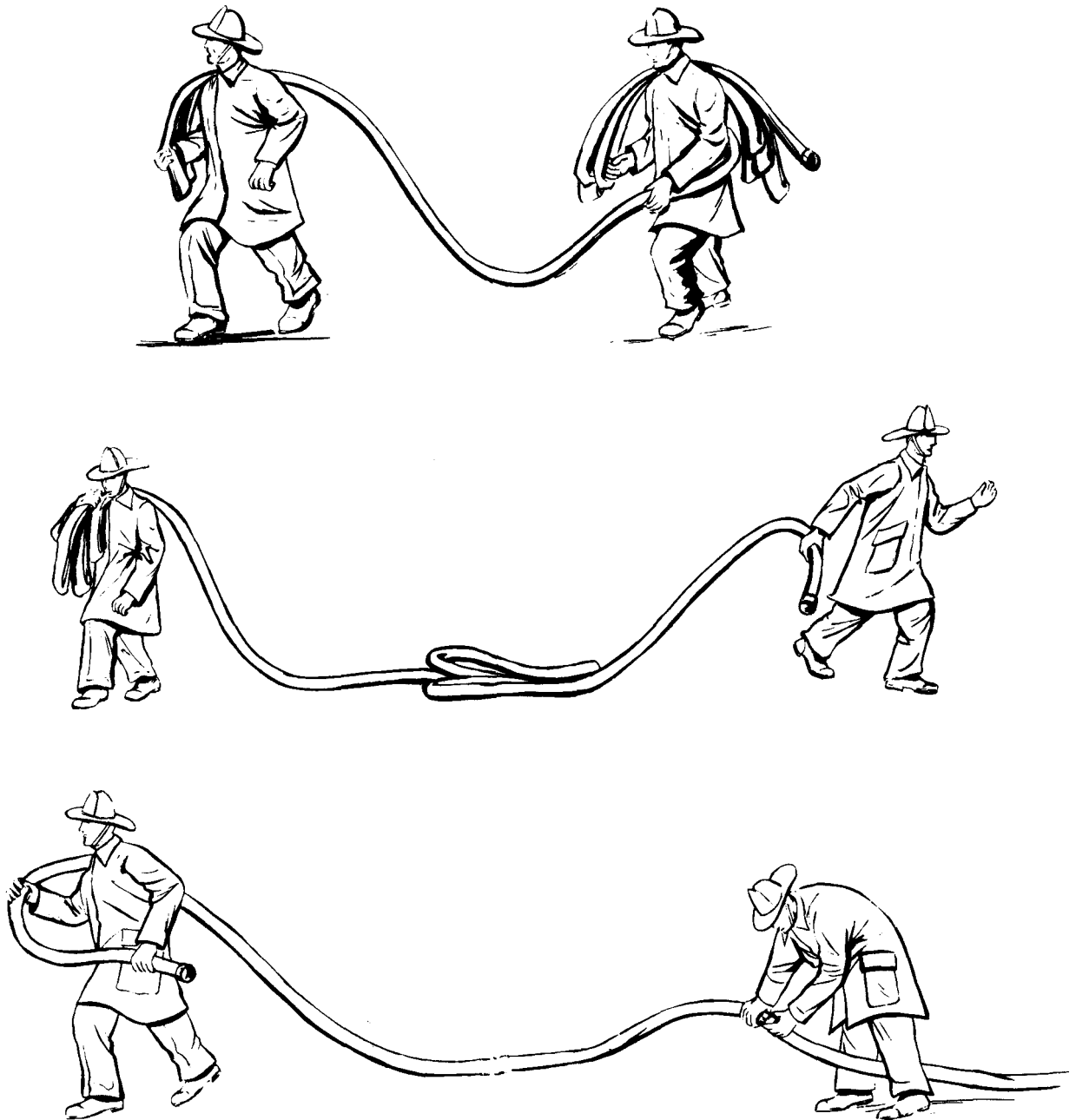

Figure 4-28. Lengthening a hose.

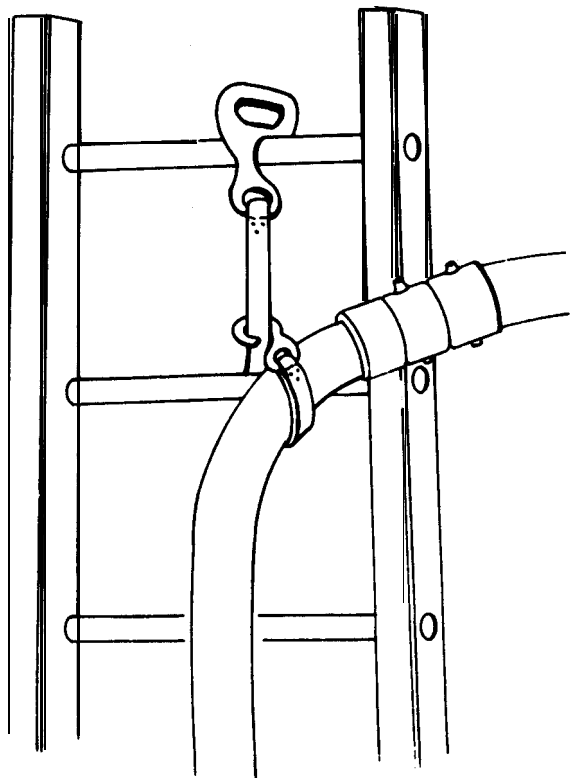

Figure 4-29. Securing hose to ladder with hose strap.



Figure 4-30. Securing hose against back pressure.

bility of the nozzle (fig. 4-30). Tying the hose in this manner increases friction loss somewhat and gives the hose a greater tendency to straighten itself. After securing it, however, one man should be capable of directing the stream. When movement of the hose is necessary, tying the hose in this manner is not recommended.

#### 4-30. Moving Hose lines

Hose lines when dry or uncharged must frequently be moved from one location to another.

a. When any great quantity of hose, such as several lengths, must be carried from one location to another, it normally requires the coordinated effort of several men to move the hose with any degree of speed and order.

b. Shoulder loads are formed by the first man, who starts with the nozzle or free end of the hose and places several layers or loops of hose over his shoulder in front and back ; but they must not extend so far as to interfere with his mobility. The next man will leave about 10 feet (3 meters) between the man in front of him and the point where he starts forming shoulder loads. This operation continues until all available manpower is utilized (fig. 4-31).

c. When a single **50-foot (15-meter)** section of hose is to be carried, a man places the main body of the hose on his shoulder and holds it with one hand (fig. 4-32). He uses his other to hold both couplings to prevent them from being dragged on the ground or damaged in some other way.

d. If a small **additional** length of hose is needed to reach the fire or to allow the hose to move to another area, a loop may be formed in the line and rolled toward the nozzle. This operation removes much of the zigzag slack from the line and lengthens it somewhat, thus increasing nozzle **mobility** and stream range efficiency-both from the standpoint of decreasing friction loss and increasing the range.

#### 4-31. ladders

A ladder is made of wood, rope, or metal, and is as definitely a part of fire service equipment as the hose, nozzles, or tools.

a. A firefighter must know how to carry, raise, and **climb** the different types of ladders issued by the Army. He should practice these procedures until the operations become as nearly automatic as is humanly possible.

b. The principal parts of a ladder are the sides, called **beams**, and the crossbars, called **rungs**. Ladder rungs are of the same design, regardless of the type of ladder. They consist of a round bar of **specified** size and strength.

c. Trussed ladders are designed as they are to make them stronger and lighter (fig. 4-33). A solid-beam ladder made of good material may meet the strength specifications, but it is much heavier than an equally strong trussed ladder, so the truss type is preferable. Trussed ladders are constructed with two beams on each side of the ladder. Some are made with one of the beams larger than the other **beam** on the same side of the ladder; others are made with all beams of equal size. With the former, the rungs are set in the





Figure 4-31. Hoving a hose line using shoulder loads.

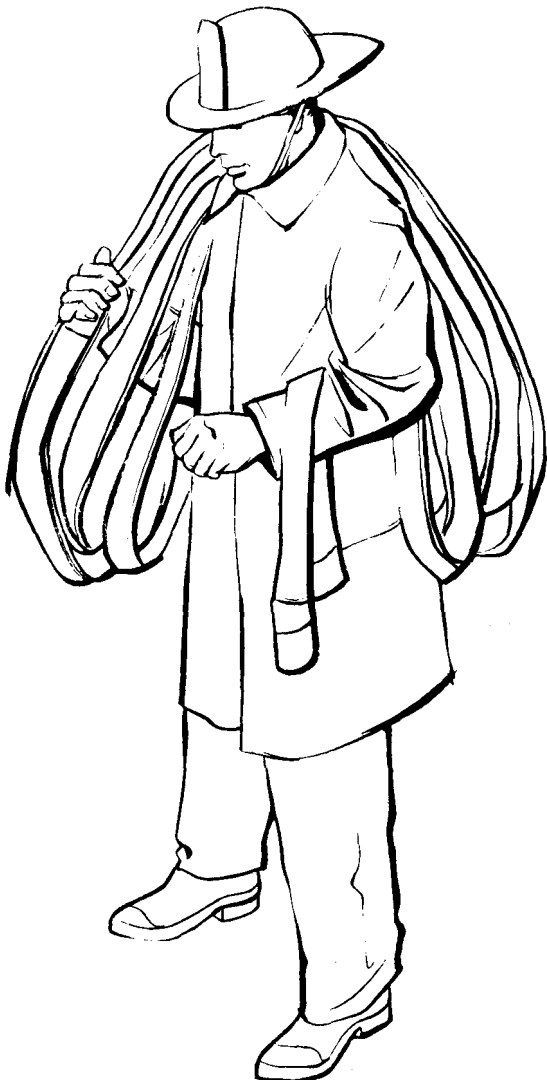

Figure 4-32. Carrying a single folded section of hose.

larger beam, which is called the rung beam; the other beam is called the truss beam. Where the beams are of equal size, the rungs are set into blocks which are, in turn, set between the two beams.

d. The beams of wooden ladders are made of either Douglas fir or airplane spruce. The rungs of a wooden ladder are made of second growth hickory or ash. Many ladders are now being made of aluminum and are much lighter in weight.

#### 4-32. Kinds of ladders

Ladders currently being used by the Army are straight ladders, extension ladders, folding ladders, roof ladders, and Bangor ladders.

a. *Straight Ladder.* Straight ladders are sometimes called wall ladders and range in length from 10 to 40 feet (3 to 12 meters). In the Army these ladders are constructed on the exterior walls of buildings. They are used as auxiliary ladders only.

b. *Extension Ladder.* As the name implies, these ladders consist of two or more sections. The base section is called the bed ladder, and the other sections are the fly ladders. The fly ladder slides through guides on the upper end of the bed ladder and is equipped on the lower end with pawls, or dogs, that hook over the rungs of the bed ladder when extended to the desired height. The fly ladders are raised by a halyard that is fastened to the lower rung and operates through a pulley on the upper end of the bed ladder. Extension ladders are made in lengths from 14 feet (4 meters),

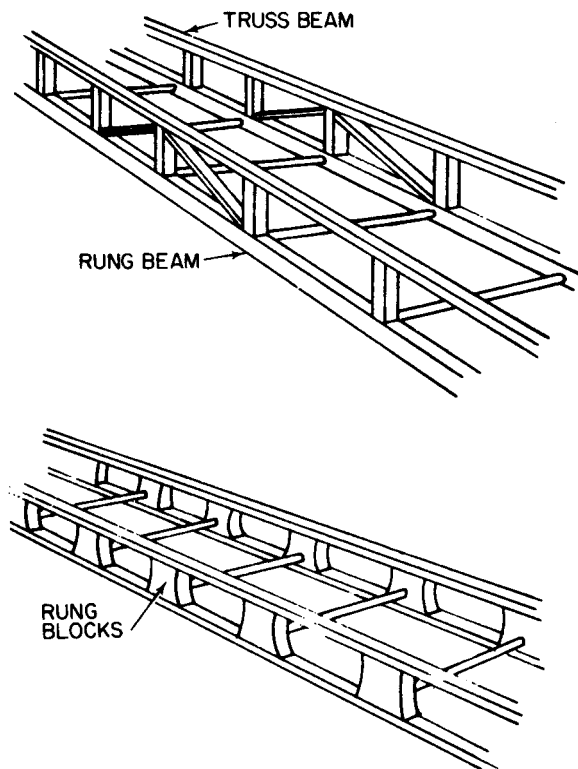

Figure 4-33. Trussed ladders.

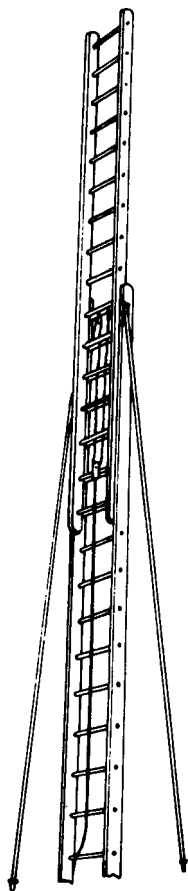

Figure 4-34. Bangor h&r.

called the “baby” extension, to aerial ladders of 160 feet (48 meters). However, extension ladders used most commonly by the Army are the 20, 24, and **36-foot** (6, ‘7, and U-meter) extensions, and the 40 and **50-foot** (12 and **15-meter**) **Bangors**.

c. **Roof Ladders.** Roof ladders issued by the Army have hooks mounted on a movable socket, which permits them to fold inward when not in use. Roof ladders range in length from 10 to 20 feet (3 to 6 meters). They may be of either the solid-beam or truss type. By placing the hooks of the ladders over roof peaks, sills, walls, or the coping of any opening, a fireman can climb the ladder with safety even though its butt may not rest on a foundation.

d. **Bangor Ladders.** A Bangor ladder is an extension ladder 40 feet (12 meters) tall or taller (fig. 4-34). Each side has a pole attached to it with a swivel. These poles are called tormentors. They have a spike in each free end, and aid in lifting and steadying the ladder while it is being raised.

e. **Folding Ladders.** A folding ladder is made up of two or more sections which are hinged for folding. A mechanism locks the hinges when the ladder is extended for use.

#### 4-33. ladder Carrying

a. **One-Man Carry.** Often a shortage of manpower makes it necessary for one man to carry and operate ladders. One well-trained man can do this, leaving the other men to perform the many other tasks necessary during an emergency. The roof ladder can be carried by removing it from the apparatus and passing either arm through the ladder at the middle of its length. The hooks should be carried forward and lowered (fig. 4-36). Extension ladders under 25 feet (7.6 meters) in length can be carried by positioning the shoulder at the center of the ladder with the heel forward, as shown in figure 4-36. This method allows the ladder to be set and raised in one continuous operation.

to 36 feet long (8 to 11 meters) require a minimum of two men, one near each end. After they have removed the ladder from the apparatus, each man passes one arm through the ladder and grasps the second rung forward (fi. 4-37). Both men must be on the same side of the ladder. The heel should be carried forward. When carrying a ladder in a crowded area, the lead man will use

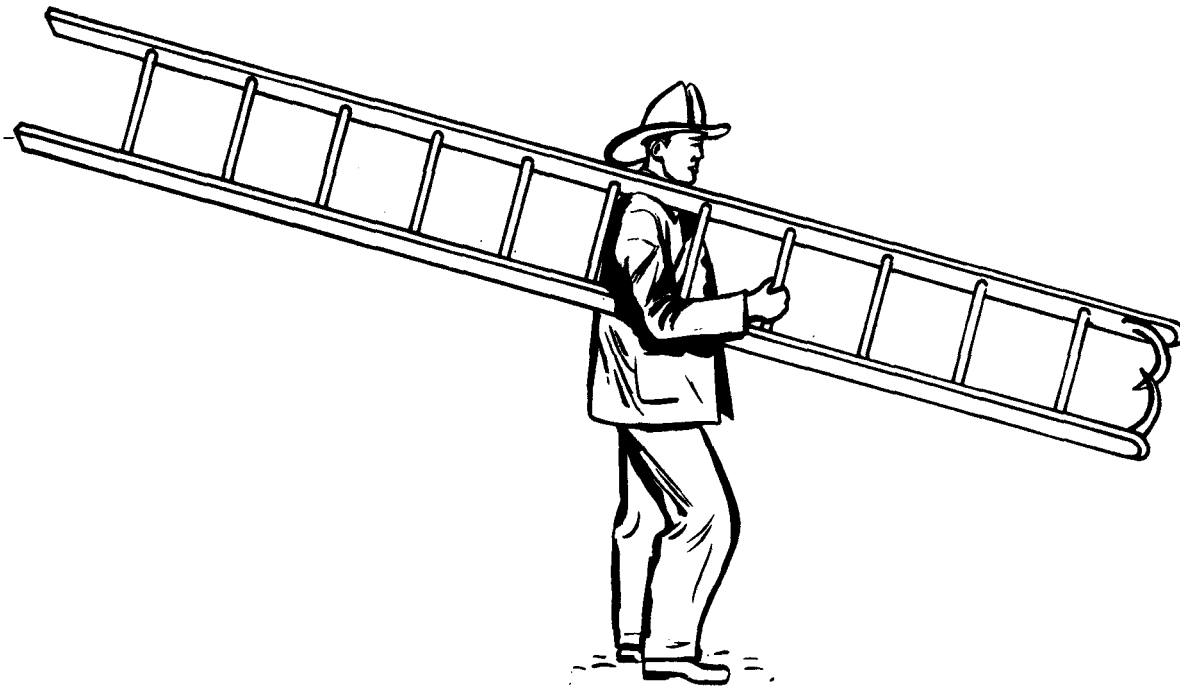

Figure 4-86. One-man carry.

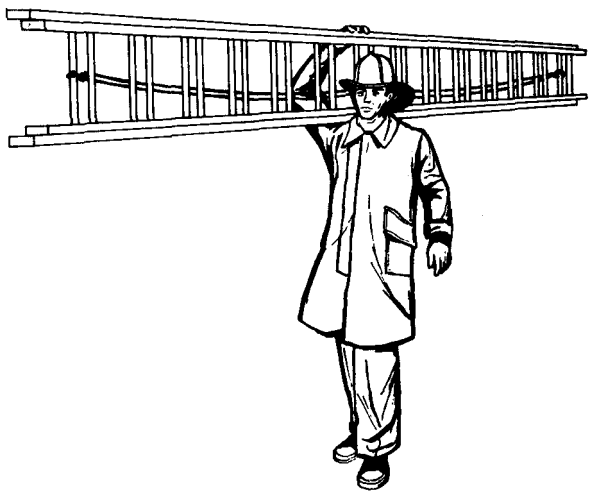

Figure 4-86. One-man extension ladder carry.

his outside hand to prevent injury to persons in the line of travel.

c. **Four-Man Carry.** Four men remove the ladder from the apparatus and place it on the ground with the fly of the ladder up. The men take positions, two near each end on opposite sides of the ladder. They face the top of the ladder, reach down, and grasp a rung with the hand nearer to it. They raise the ladder on their shoulders and carry it, as shown in figure 4-38.

d. **Six-man Carry.** This carry is used for the Bangor ladders and is the same as the four-man

carry, except that two additional men are placed in the middle on opposite sides of the ladder (fig. 4-38).

NOTE

Ladder drills tie in very closely with hose operations, because ladders are frequently needed for maneuvering the hose to an effective fire-extinguishment position. In addition, ladders are needed for rescue, ventilation, and salvage work, and for other fire fighting duties.

4-34. Ladder Raising

As in ladder carrying, ladder raising is an operation requiring practice and cooperation. Before a ladder can be raised, it must be determined how far the heel of the ladder should be placed from the building. There are two methods to determine this. One is to divide the length of the ladder by 5 and add 2. For example, if a 35-foot (U-meter) ladder, fully extended, is to be used, the distance would be  $(35 \div 5) + 2 = 9$  feet (2.7 meters). The other method is simpler and more commonly used. The distance is determined by dividing the length of the ladder by 4. Thus, if a 36-foot (11-meter) ladder is to be used, divide 36 (11) by 4 and the result is approximately 9 feet (2.7 meters) (fig. 4-39).

a. **One-Man Raise.** There are two methods by

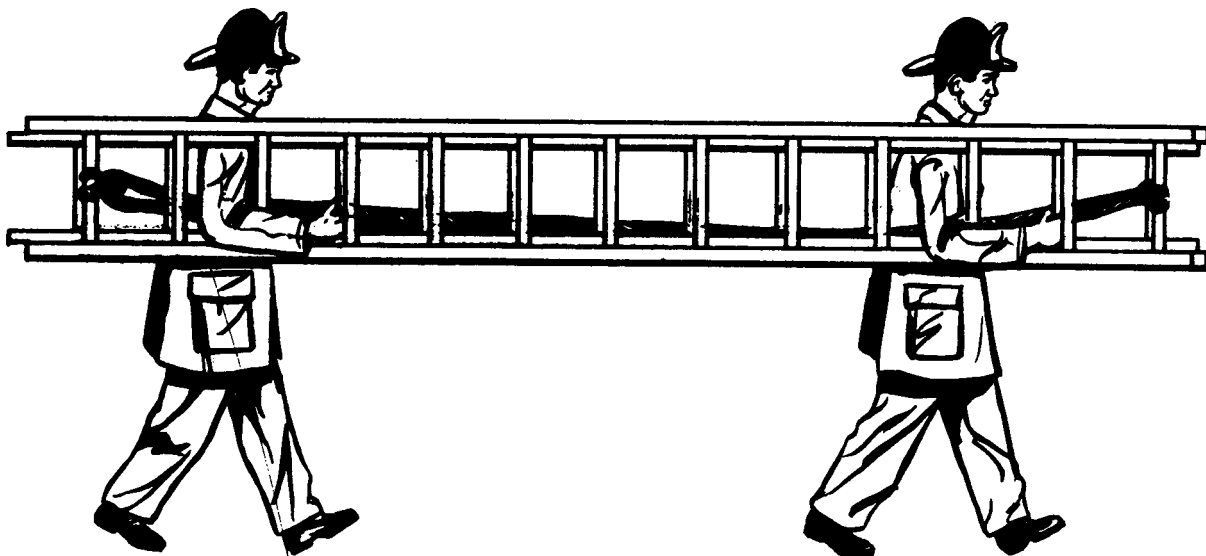

Figure 4-37. Two-man ladder carry.

which one man can raise a ladder. The first method, while slower, is easier for the beginner.

(1) Carry the ladder as described in paragraph 4-33 to the desired location.

(2) Place the heel of the ladder against the building.

(3) Grasp the top rung and raise the ladder to a vertical position while walking toward the heel, using every other rung (fig. 4-40).

(4) Grasp the ladder by the rungs with both hands, about three rungs apart. Lift the ladder off the ground and carry it back to the desired distance from the building.

(5) If the ladder is the extension type, step around in front of the ladder, grasp a rung at head height with both hands, and pull away from the building until the ladder is again vertical.

(6) Still facing the ladder, place one foot against the side of the beam, the knee against the front of the beam, thereby steadying the ladder. Allow the top of the ladder to lean slightly toward the building to counteract the pull of the halyard.

(7) Raise the extension to the desired height and lock the *pawls*. Lower the top so that it rests firmly against the building (fig. 4-41).

#### NOTE

The other method of the one-man raise is faster but requires more skill. Carry the ladder as shown in figure 4-35. When the heel of the ladder is at the desired position, start pressing down on the heel, with the hand holding the ladder; when

the heels are nearly parallel with the ground, lean forward and give a sharp push with the shoulder. This will set the ladder in the vertical position. Raise the extension as described in (5) through (7) above.

*b. Two-Man Raise.* When enough manpower is available, two men should be used for raising 24 and 26-foot (7 and 8-meter) ladders. The following method should be used:

(1) The ladder is removed from the apparatus and carried to the desired position.

(2) The heel should be spotted at a point directly below where the top is to rest.

(3) Where there is enough distance between buildings, the ladder is positioned at right angles to the target building; otherwise the ladder must be positioned parallel to the target building. The ladder is laid flat with fly ladder up.

(4) The man designated to heel the ladder stands on both heel plates, reaches forward and grasps a rung with both hands, and then leans back to assist in the raising.

(5) The other man stands at one side of the ladder, facing the top. He reaches down and grasps a rung near the top, raises the ladder over his head, swings in under the ladder facing the foot, and walks toward the foot using every other rung. If the ladder is positioned parallel to the building, both men grasp the beams and swing the ladder around with the fly inside.

(6) The two men are now facing each other through the ladder. The man on the inside stead-

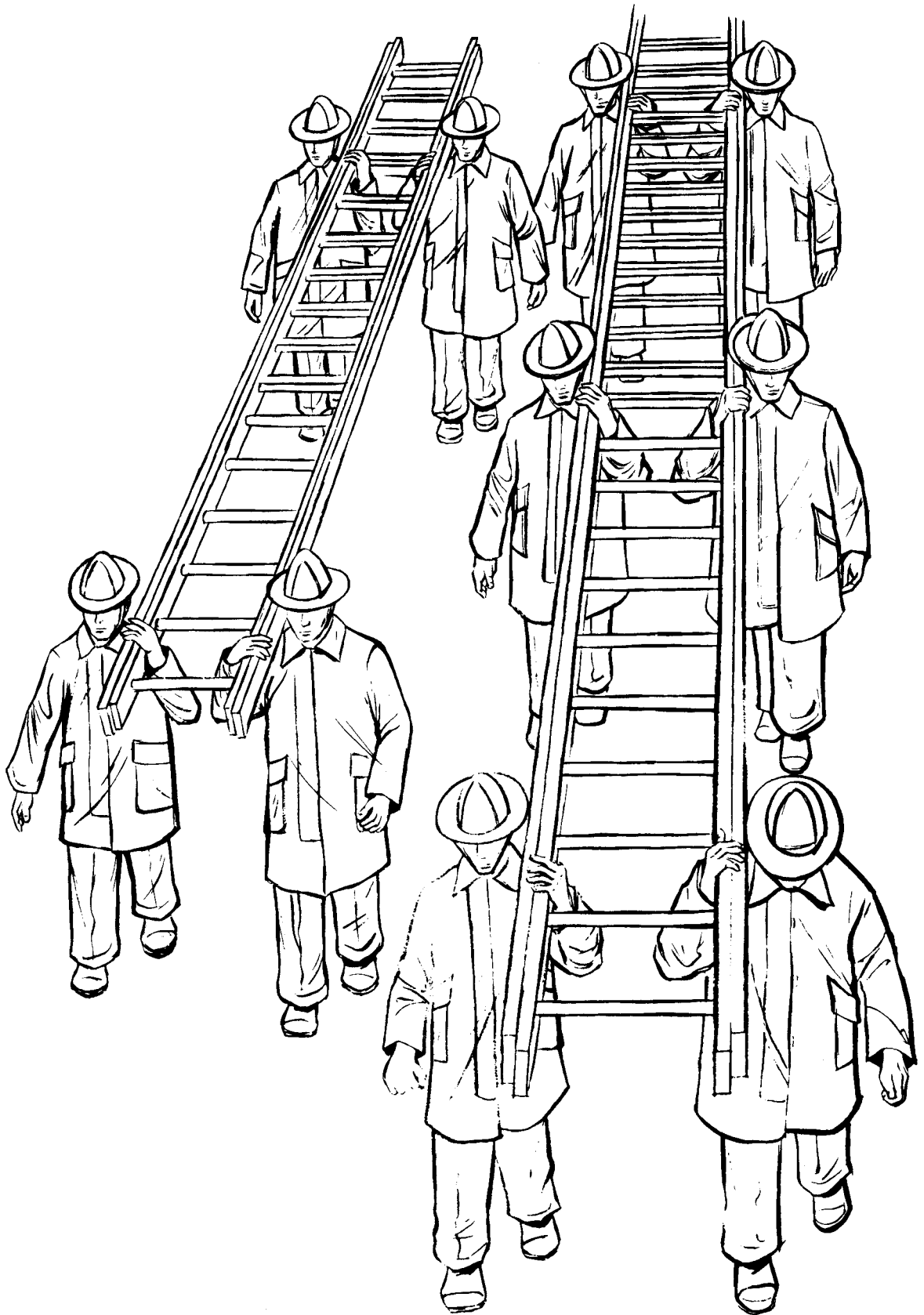

Figure 4-38. Four and six-man ladder carries.

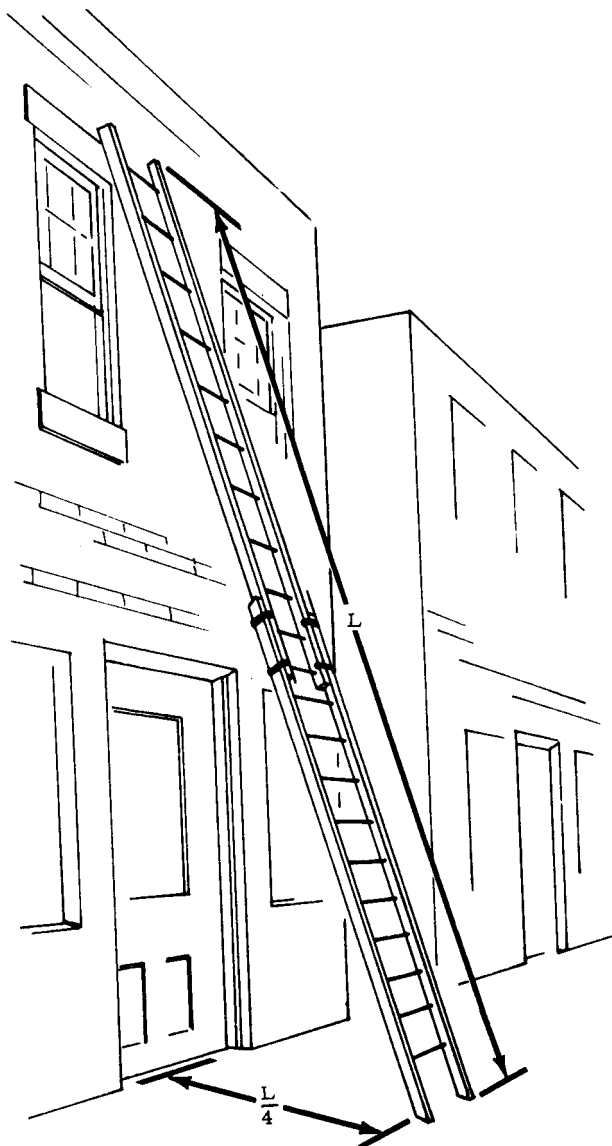

Figure 4-39. Proper ladder angle.

ies the ladder while the man on the outside raises the fly to the desired height and locks the pawls (fig. 4-42).

(7) The ladder is then lowered to the building by both men.

(8) To lower the ladder, reverse the operations.

**c. Four-Man Raise for Bangor Ladders.** Although six men should be used to raise Bangor ladders, shortage of manpower frequently makes it necessary to use the four-man raise. The procedure is as follows:

(1) The four men remove the ladder from the apparatus and carry it to the desired point. Then ground it at right angles to the building with the



Figure 4-40. One-man ladder raise.

heels close to the building. The four men then take their positions as shown in figure 4-43.

(2) Nos. 1 and 2 release the tormentors and pass them overhead to Nos. 3 and 4; then they return to a position just below the tormentor swivels.

(3) Facing the top of the ladder, Nos. 1 and 2 grasp a common rung and raise the ladder overhead; then they swing around in under the ladder and raise it to the vertical position by walking toward the foot. The pole men assist as soon as the ladder is raised above the beam men's heads.

(4) Nos. 1 and 2 grasp a convenient rung, and with their other hands on the beam, lift and carry the heel to the proper distance from the building.

(5) Nos. 1 and 2 each place a foot on the rung, and Nos. 3 and 4 pull the ladder to the vertical position with the tormentors. Nos. 1 and 2 then raise the ladders and lock the pawls.

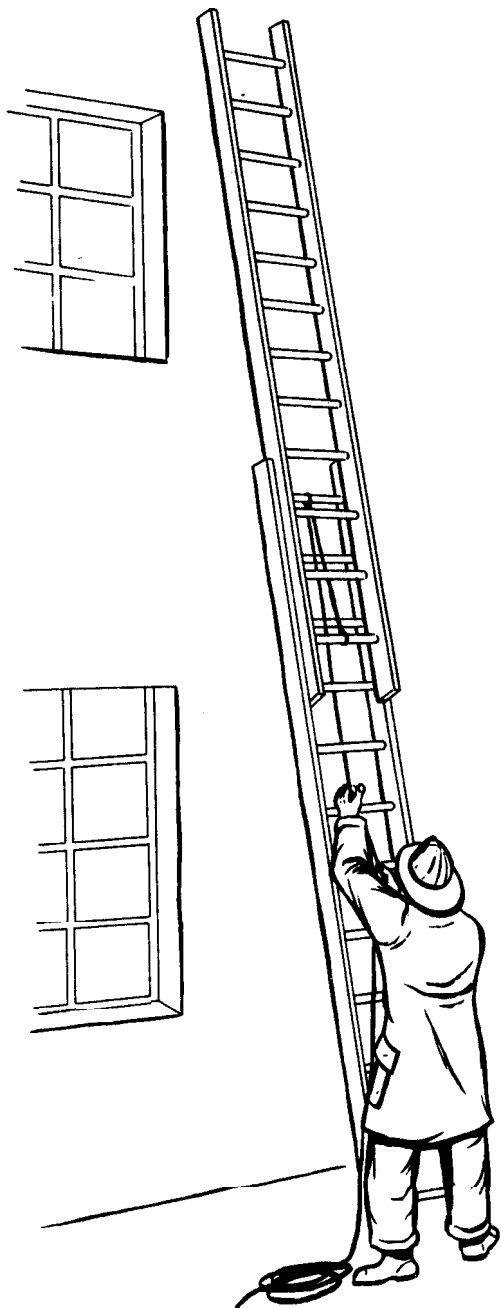

Figure 4-41. Placing of one-man raised ladder.

(6) The ladder is then held in place by Nos. 1 and 2 while Nos. 3 and 4 lower the ladder to the building with the tormentors. The tormentors are then locked in place.

**d. Six-Man Raise for Bangor Ladders.** Six men should be used to raise Bangor ladders whenever possible. The procedure is as follows :

- (1) The men remove the ladder from the apparatus and carry it to the desired location.
- (2) The men ground the ladder with the fly

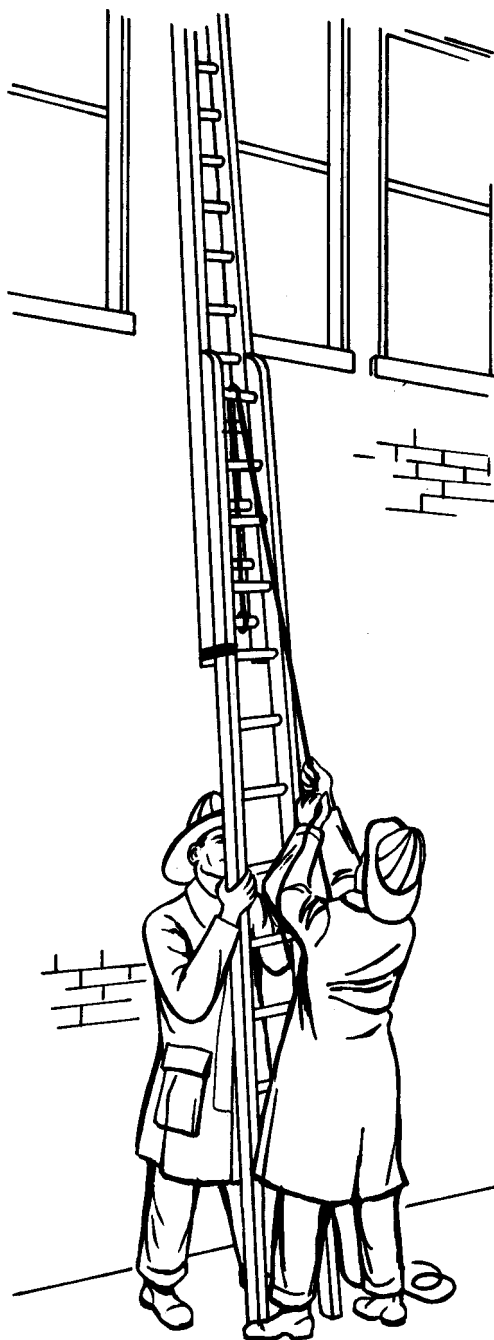

Figure 4-42. Two-man ladder rake.

ladders on top, then they take their positions as in figure 4-44.

(3) Nos. 1 and 2 release the tormentors by pulling the keys, raise the ends, and pass them to Nos. 3 and 4, who, in turn, pass them to Nos. 5 and 6, the tormentor men. With the spur of the tormentors between the first and second fingers of the hand nearest the spur when standing outside the tormentors, the other hand grasps the **tormen-**

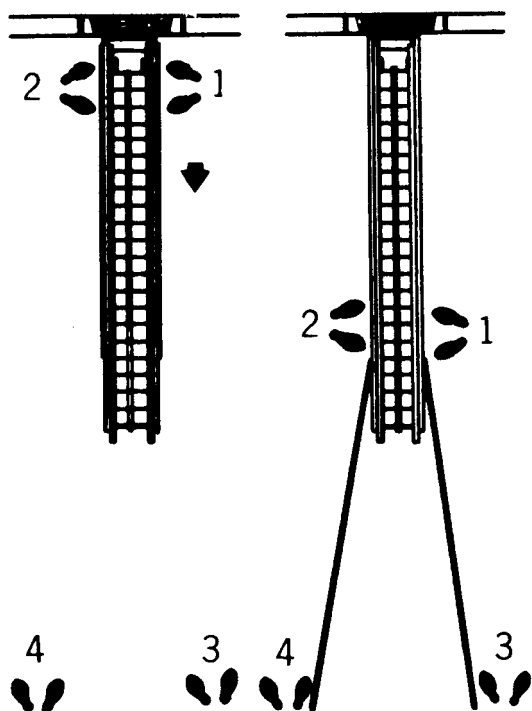

Figure 4-43. Four-man Bangor ladder rake.

tor at arms' length. These men should be about 5 feet (1.5 meters) apart.

(4) Nos. 1 and 2 stand on the heel plates and reach over and grasp a convenient rung as the ladder is raised.

(5) Nos. 3 and 4, facing the top of the ladder, reach down and grasp a common rung, raise the ladder overhead, swing under the ladder, and raise it using every other rung. Nos. 5 and 6 take the weight from Nos. 3 and 4 with their tormentors as soon as possible, pushing the ladder to the vertical position.

(6) When the ladder is vertical, No. 5 will swing to the inside of his tormentor pole and carry it around to a position at right angles to the other tormentor (fig. 4-45). This steadies the ladder and allows it to be set plumb.

(7) Nos. 3 and 4 heel the ladder while Nos. 5 and 6 lower the ladder to the building with the tormentor poles. The tormentors are then set under the ladder to prevent sidesway.

(8) To lower the Bangor ladder, reverse the operations.

#### 4-35. Ladder Climbing

a. Ladder climbing is involved in the duties of rescue, ventilation, and extinguishment, including the moving of hose, ladders, and other **cumber-**

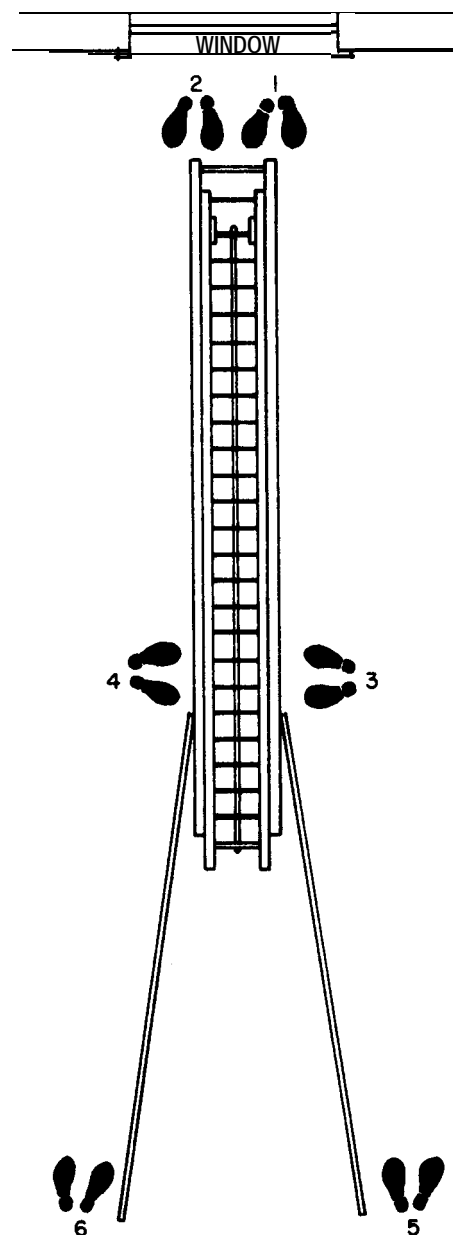

Figure 4-44. Six-man Bangor ladder raise.

some but necessary equipment. Since all these duties must be carried out swiftly under the strain of a fire emergency, ladder climbing becomes a highly important skill. To acquire ease in ladder climbing and its related uses, the average man needs much practice.

**b.** In climbing a ladder, one hand is always on one of the rungs, unless an article of equipment is being carried up or down the ladder. If something is carried in one hand, it should be slid along the beam, if possible, to give the climber at least a limited hold at all times.



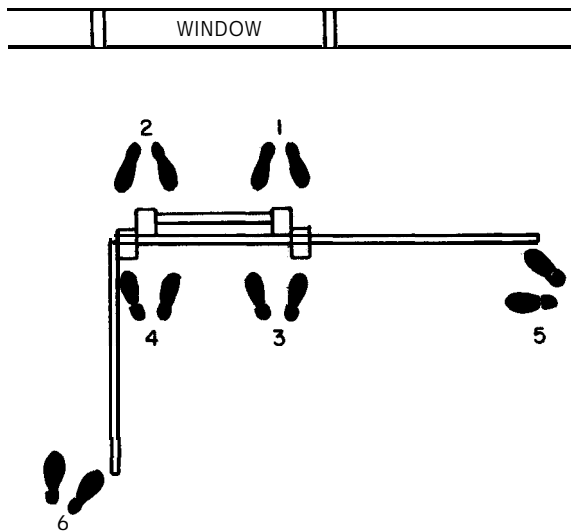

Figure 4-45. Position of tormentor men-Bangor ladder.

c. An unnatural coordination exists in proper ladder climbing, for while one foot or the other must be placed on every rung, one hand or the other moves only once for each two rungs ascended by the feet.

d. The feet should be placed in the center of each rung to prevent the ladder from wobbling. For speed and smoothness, the body should be carried in a nearly upright position with the arms moving outward almost in an arch as the hands are changed from rung to rung. The ball of the foot should be placed on each rung to get complete advantage of the leverage afforded by the angle. When poor weather provides little traction between the boot and rung, the arch in the center of the boot should be placed on the rung as a safety measure. Using the ball of the foot for climbing permits more speed and smoothness and takes less effort. Climbing should be steady and smooth, and no attempt made to run either up or down a ladder. The upper part of the body should move so evenly that it appears to be standing on an escalator.

e. Locking in on a ladder means simply placing the leg between two rungs and bringing the foot back out between the next lower rungs and locking the foot either around the rung or around the beam (fig. 4-46). This leg lock enables the man on the ladder to work with both hands free to handle hose, ladders, and tools. Men should anchor themselves to a ladder with a rope hose tool or a safety belt only when one position must be kept for a long time. Short men are more comfortable when they lock one foot around the rung above the one

on which the other foot is placed, while tall men usually are more at ease when they lock one foot around the beam.

f. For safety, especially when there is considerable weight and activity on a ladder, it should be anchored to the building with a rope hose tool, hose chain, or strap. This anchor prevents the ladder from slipping or turning over when the load is shifted; it also eliminates much of the vibration caused by activity on the ladder. When necessary, the slack must be taken from the rope by twisting it or taking an extra turn around the ladder rung.

#### 4-36. Pumping Operations

It is difficult to establish a definite, rigid procedure for the operation of firefighting pumps because fire services employ many types of pumps. Each type of pump normally is manufactured by many corporations, and each corporation, in turn, locates the pump valves and levers in various places on the apparatus. Although comparable valves and levers may serve almost identical purposes, they often differ considerably in appearance. Consequently, it is practical to give here only the operational sequence, eliminating details of description and location of the valves, levers, and gages.

a. *Placing the Booster Line in Operation.* All Army pumpers have booster tanks which contain a minimum of 150 gallons (568 liters) of water. The speed and efficiency with which a booster line can be placed in operation largely determines the amount of damage by smoke, fire, and water that can be prevented. The proper use of the booster line is frequently responsible for the extinguishment of fires at an early stage.

(1) To place the booster line into operation, first remove the line from the pumper and assign one crewman to man the nozzle. Since the hose usually is 1 inch (2.54 centimeters) or less in diameter, one man can operate the nozzle efficiently with the limited amount of pressure generated and volume discharged. Next, start the pumper engine, if not already running, and allow it to idle. Then place the pump in gear.

(2) Open the pump intake valve leading from the tank to the pump and allow the pump to fill with water. Then open the pump discharge valve leading from the booster line. With the engine still idling, allow the booster line to fill with water to the nozzle. Accelerate the engine until the gage

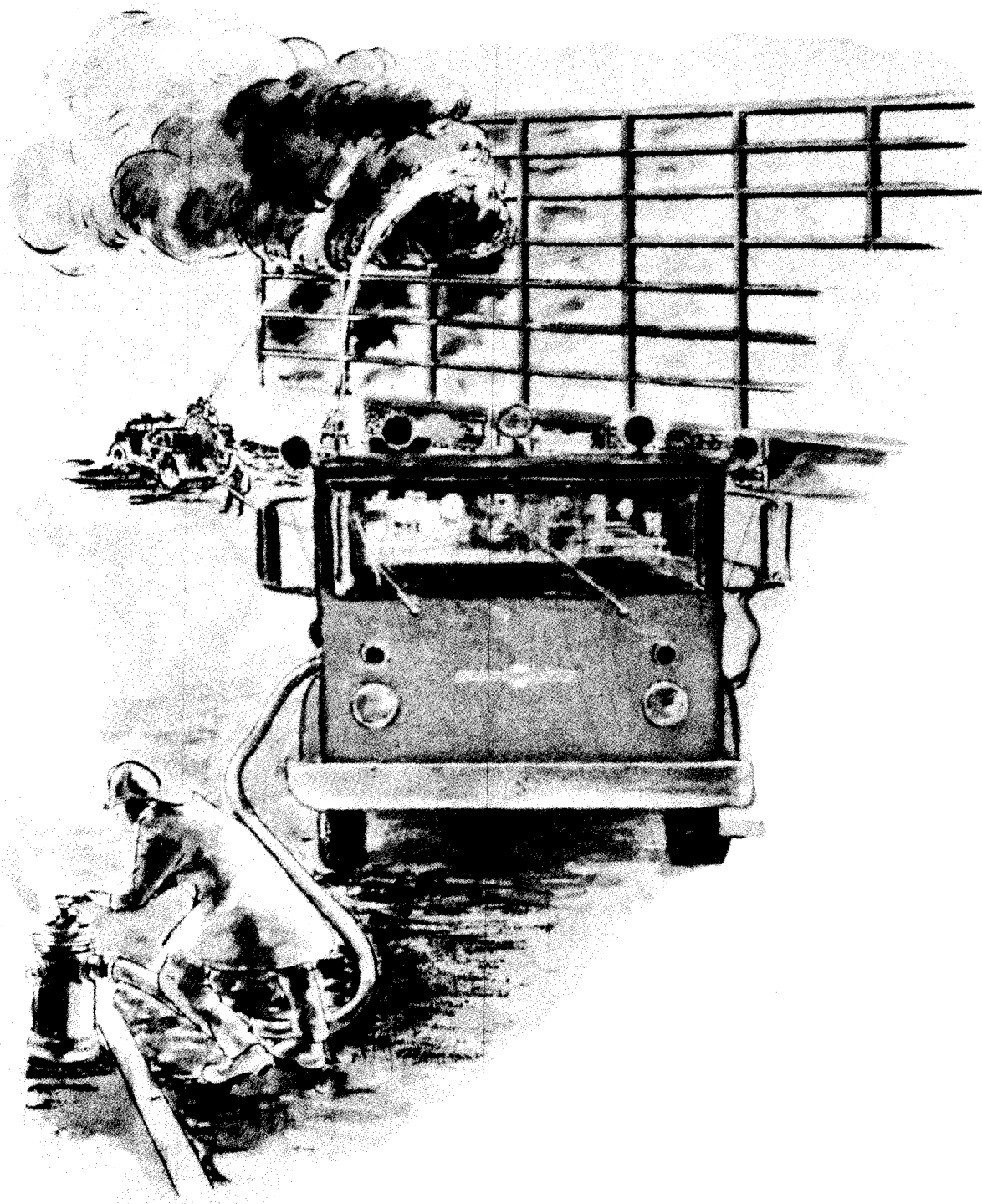

Figure 4-46. Looking in on a ladder.

on the control panel shows the pump pressure to be 100 psi, then open the nozzle. When it becomes desirable to shut down the pump, retard the throttle, close the pump discharge valve and the inlet valve, take the pump out of pump gear, and place it back in road gear. If it becomes necessary to close all discharge valves during pumping operations, the pump should be taken out of "pump" position and placed in "road" position. This will prevent the water in the pump from "boiling." The relief valve will take care of the pressure and heat for a short time, but not for extended periods.

b. *Taking Water from the Hydrant.* The pri-

mary rule to follow when taking water from a hydrant is as follows: A fire hydrant should be opened slowly to prevent pressure surges, and completely to prevent undue wear. To take water from a hydrant with a pumper (which may be necessary because of the great size of the fire or insufficient hydrant pressure), the pumper must be located strategically in relation to the hydrant. This will permit the suction hose to be connected conveniently and without kinking (fig. 4-47). The cap on the 4½-inch (11.43-centimeter) "steamer" connection of the hydrant should be removed and also the suction hose connected to the plug and the intake on the pump (which also requires the re-



*Figure 4-47. Pumping from hydrant.*

moval of a cap). The process is continued as follows:

(1) Break the hose at the proper coupling and connect it to one of the discharge outlets from the pump. After the pumper discharge valves and churn valves are checked and found closed, open

the hydrant valve. Start the pump engine, if not already running, and let it idle while the pump is put into gear. Open the discharge valve on the pump and accelerate the engine until the gage indicates the desired pressure.

(2) The desired pressure is determined by

taking into consideration the size, type, and length of the hose, the nozzle size, and the vertical distance from the pumper level to the point at which the nozzle is elevated, according to the principles of hydraulics presented in **section II** of chapter 4. The pump operator should be capable of arriving at the desired pump pressure within seconds after the layout is made and observed.

(3) When pumping from a substandard water system, pumpers of comparatively large capacity may collapse their intake lines if the flow into the system is less than the discharge capacity of the pump. In this event, the pump operator must watch the intake gage as well as the pressure gage, and regardless of the pressure maintained, should regulate the throttle so that the intake pressure does not fall below **5** psi. This

precaution is taken to prevent a collapse of the soft suction hose (intake line) which would cut off the pumper's water supply **completely**. If the hydrants are of such limited capacity, small nozzle tips and fewer hose lines should enable continued operations. If the hydrant suction is weak the hard suction hose should be used. The suction pressure should not be permitted to drop below 10 psi. This will permit a 5 psi error in the gage accuracy without the **danger** of collapsing a water main.

*c. Pumping from Draft.* When pumping from draft, whether the source is a tank, a pond, a lake, or a moving stream, the intake side of the pumper should be located as close to the water body as is feasible (fig. 4-48).

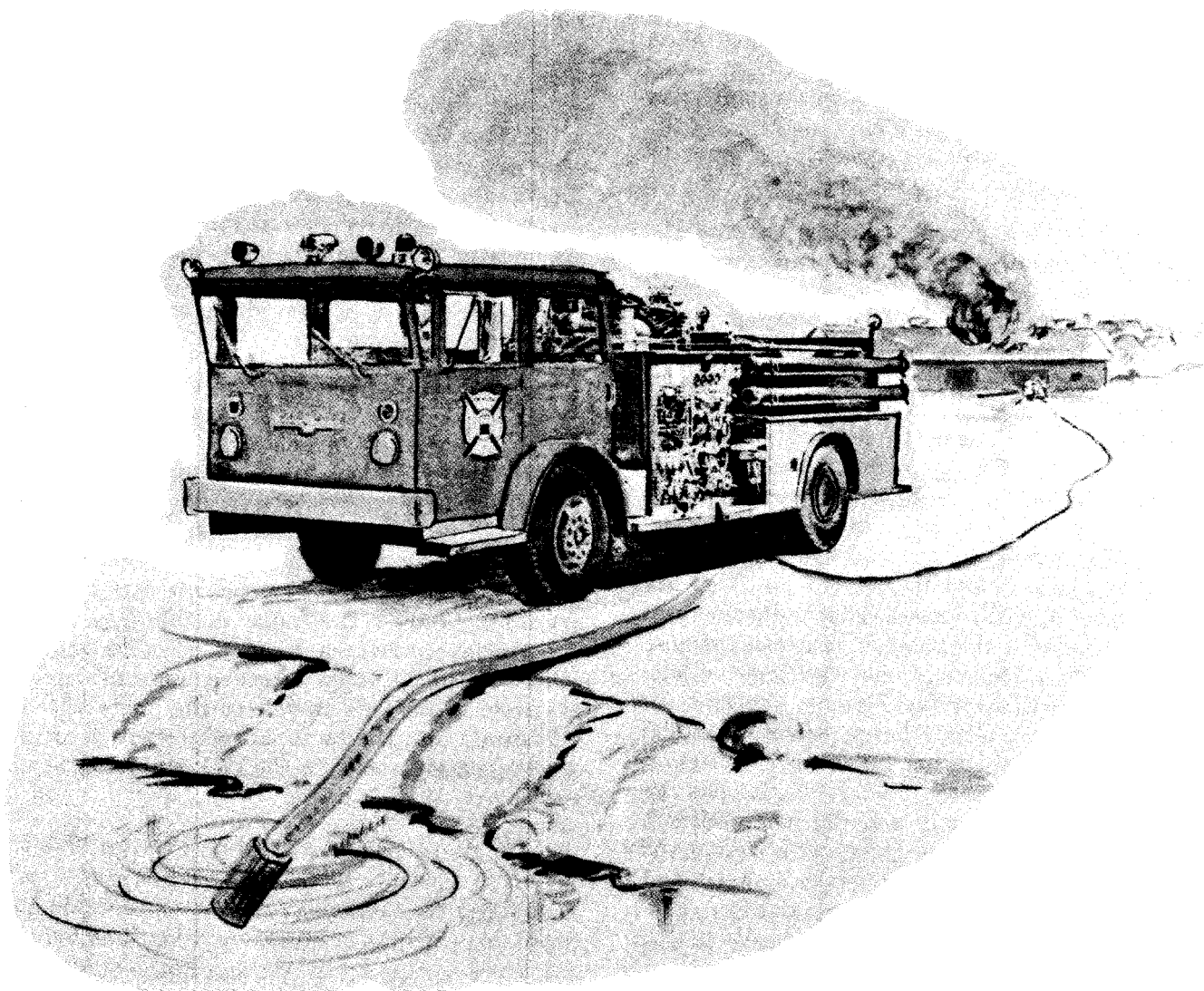

Figure 4-48. Pumping from draft.

(1) The location should have a solid foundation and be capable of bearing the weight of the truck and withstanding the vibration created by the engine and the pump. The pump lift, or the height from the water surface to the pumper, should not exceed **12 feet (3.66 meters)** unless absolutely necessary. Shorter lifts **are** capable of producing greater overall volume and pressure efficiency. The emergency brake of the pumper must be set, the gearlift lever placed in neutral position, and the throttle opened only slightly to maintain a good idling speed. Check blocks are placed at the wheels if the vehicle is on an incline.

(2) Regarding the suction connections, the gaskets of the *hard* suction connections must be in place before connections are made. The suction strainer is attached to the end of the suction **hose**. A rope is secured to the suction strainer to **facilitate** handling, and tied into position. The strainer beneath the water surface is submerged to a depth of 18 inches to 4 feet (0.46 to 1.22 meters), depending upon the depth of the water source and the capacity of the pumps. Where the depth of the water permits, the strainer should be at least 12 inches (0.305 meter) above the bottom.

(3) If the water is too shallow to allow the suction line and strainer to be suspended in it and if the bottom of the water source contains sand and debris, the strainer must be protected to prevent debris from entering the pump. Lumber sheeting, sheet metal, boxes, the blade of a shovel, or any other flat container or object may be placed underneath and around the suction strainer to keep it clear. The strainer should be tied into **position** with a rope to prevent it from drawing air. If it is impractical to use rope, a large board or some other heavy material is placed over the suction strainer to keep it submerged. All openings are closed including drains and booster connections on the suction side of the pump. The necessary hose couplings are attached to the discharge outlets. When priming a centrifugal pump, the first requirement is that all discharge valves be closed and intakes, except the one being used, be tightly capped. The primer should then be started and the valve between the primer and the pump opened. When the pump is primed (filled with water) the pump should be engaged, the primer stopped, and the **discharge** valve(s) opened very slowly to prevent loss of the prime. Once the pumper is discharging water, the pressure desired as well as the number of lines needed can be maintained by coordinating the intake and discharge pressures

with slow and deliberate adjustments of the throttle.

(4) Centrifugal pumps may be equipped **with** either a relief valve or a pressure-regulator valve. A relief valve is set at the predetermined pressure; then when a line is shut off at the nozzle, the backpressure at the pump opens a bypass valve which reroutes the water from the discharge to the intake side of the pump, thus preventing a water hammer. A **pressure-regulator** valve is set at a pressure determined by existing conditions. These conditions are governed by the number of lines being used, their lengths, and the size of the nozzle tips. When a line is shut off at the nozzle, the backpressure thus **created** at the pump actuates a **governor** that reduces the engine speed and the pump pressure.

(5) When the pump is in operation the engine temperature must be watched constantly so as to maintain an efficient engine temperature of **160° to 180° F. (71° to 82° C)**. The temperature can be controlled by the cooling-water-supply valve. This valve is manipulated as often as necessary to maintain the desired engine temperature. However, the **valve** should never be suddenly opened or closed, for this practice heats or chills the engine too rapidly. The excess pressure **coming** from the fire pump is likely to damage the radiator or cooling system if the cooling valve is opened too far or too fast.

(6) Water is pumped from the booster tank on the fire truck or trailer in much the same manner as it is from a **hydrant**. Since the water in the tank is above the level of the pump opening, the valve in the connection between the tank and the pump will permit water to flow from the tank to the pump by gravity, eliminating the necessity of priming. Because of this connection, care must be exercised to have the valve in this line **closed** when pumping from a hydrant or other gravity source of supply under pressure, since the excess pressure on the suction side of the pump will be introduced into the tank and will result in overflowing, causing leaks in the tank and other damage.

(7) As previously stated, it is not possible to set forth specific operating procedures for all pumps, but the foregoing will serve as a guide for the basic principles of operation. Almost all valves and levers on the pump are descriptively labeled. When they are not or when the nomenclature is not completely understandable, the pump operator

may, if he understands the purpose and principles of the operation, follow out each lever and each

line **leading** away from the valve to its source and thus determine its specific purpose.

## Section IV. ACTION ON ARRIVAL, **SIZEUP**, AND **FORCIBLE ENTRY**

### 4-37. Introduction

After responding to as few as a dozen fire **emergencies** the firefighter will be convinced of the great variation in fire conditions and the variation in procedure required to put out each fire. The first action of the firefighting crew immediately upon arrival at the fire is probably the greatest single factor in determining the success or failure of the operation. **Enroute** to the fire and upon arrival, crewmen must quickly analyze the part that each will play in the rescue and extinguishment procedures. The crew chief or senior man will make the basic assignments. Even after the assignments are made there is a great necessity for individual initiative in the details of execution. This initiative increases with **experience** and study.

### 4-38. **Sizeup**

The first duty of the crew chief and the crew is to "size up" or make a quick appraisal of the situation and determine what the conditions demand and the order of their procedures.

a. The following six conditions must always be **taken** into consideration :

- (1) Life hazard involved or the rescue work required, if any.
- (2) Exposure hazards from both the interior and exterior viewpoint.
- (3) Type of building construction (consider the possibilities of collapse).
- (4) Content hazards to both the occupants and the firemen.
- (5) The accessibility of the fire.
- (6) The type and amount of fire equipment required.

**b.** Whether persons occupy a burning building should be known before firefighting operations begin. Also, how many sleep there at night (if the fire occurs at night), and the facilities for exit and their condition, capacity, and usability. For example, open stair wells and fire escapes may be **blockcd** by heat and flame, and elevators may be inoperative; if the roof over the elevator or its shaft is involved in fire, the elevator should not be used. On the other hand, stairways cut off at each

landing, **inclosed** smoke towers, or horizontal exits into adjacent wings or buildings are likely to provide safe exits. Fires in buildings used for public assembly, such as theaters, dancehalls, clubs, schools, and hospitals, and for sleeping quarters offer the greatest life hazard.

c. The roofs and walls of adjacent buildings may be endangered by heat radiation or by an infiltration of heated smoke and **gases** from the **initial** fire, which may suddenly ignite or explode. Frequently the building or buildings exposed are more important to save than the burning building from the standpoint of life hazard, content value, or current need. Where the fire is well advanced, the first streams of water should be used to protect such exposed buildings. The direction of the wind, slope of the ground, distance between the buildings, extent to which the fire has spread and other considerations must be carefully appraised before action is taken.

**d.** Internal exposures from floor to floor via elevator shafts, open stairways, light walls, etc., must also be considered. When the fire is located in the basement or lower floor, prompt action in getting hose streams into operation at points where fire is apt to spread is an important means of making an effective fire stop.

e. The type of building **construction** is a factor which determines the time that fire will require to cause the collapse of a structure. This is important in determining whether a building can be safely laddered, and it will also determine whether men should be sent inside the building. Heavy timber construction will hold up under higher temperatures and **for** a longer time than unprotected steel. Reinforced concrete will withstand more weight of water than ordinary **brick-joisted** buildings.

**f.** Content hazards to the occupants and firefighters consist of explosive stock, toxic fumes, chemicals, acid **carboys**, **compressed-gas** cylinders, high-voltage wires, etc., which, when subjected to heat **or** hose streams, may jeopardize the safety of personnel. All of these hazards must be considered before ordering specific procedures for fire **extinguishment**. Knowledge gained during previous building inspections is of real value at such a time.

g. The characteristics of explosives should be studied, and, with the advice and assistance of the ordnance officer, advance conclusions should be reached regarding the time and heat necessary for detonation.

h. Toxic fumes require the use of compressed air, self-contained demand breathing apparatus.

i. Compressed-gas cylinders should have been previously inspected to learn the amount of pressure required to rupture them. Also, whether a cylinder is shatterproof should have been determined. The flammability, rate of expansion, and other pertinent properties of the cylinder contents should have been obtained so that the chemical reactions in the event of fire can be anticipated. Liquid and powdered **chemical reactions** in the event of fire can be anticipated. Liquid and powdered chemicals must be respected from the standpoint of their gas-liberating qualities, the toxicity of the gas, the type of container (which may hasten or retard its release), and the general characteristics of the chemical when exposed to heat and water.

j. High-voltage wires can electrocute personnel over a widespread fire area where water is generally present. If the circuits are not cut off by the time water is used, extreme caution must be observed in stationing personnel **during** extinguishment. Personnel must be kept free of water which is in contact with sources of electrical currents.

k. Frequently mud, excavations, traffic jams, ditches across roads, blocked alleys, and a multitude of other obstacles prevent an approach to the fire from the most favorable direction. Previous knowledge of such conditions, which allows the crew chief to take alternate action, will prevent considerable delay.

l. In some fire emergencies it is possible, even before the firefighters reach the fire location, to determine that additional men and equipment will be needed. This can be judged by the nature and extent of the headway which the fire has already gained. When a large fire is observed in an area where no **open** fires should be found, a second alarm should be turned in as quickly as possible. This may be done from the alarm box, if one is available, or over a two-way radio. On small bases, where there are no firefighters available to respond to a second alarm, a thorough knowledge of available outside aid is invaluable.

m. In most responses or runs, it will be found upon arrival that there is no large fire, but rather

a small fire consisting of something such as burning rubbish, automobile or furniture upholstery; or oil overflow around the base of heaters. In such cases the crew chief should order one or two of his men to use the appropriate extinguisher or the booster line. The remainder of the crew should remain on the apparatus to await further orders.

n. In some instances firefighters arriving at the scene of a fire may find only an odor of smoke instead of an actual fire. If the source of smoke cannot be traced immediately and the odor continues, a thorough investigation should be made from the lowest level to the rooftop. Smoke frequently is blown into a building from the outside or may result merely from the temporary abnormal operation of a heating appliance. If there is any doubt regarding the source of the smoke, the firefighters will remain until the source has been discovered and corrective action taken.

o. When the **sizeup** discloses the need for immediate action, the following steps should be taken: Call for additional help (if required), initiate rescue work (if required), ventilate, locate the fire, close in, extinguish, salvage, overhaul, and investigate. Although listed in sequence, these steps are carried out almost simultaneously if enough personnel are available.

#### 4-39. **Forcible Entry**

Forcible entry means gaining entry to closed spaces by opening locked doors and windows, roof, floors, skylights, partitions, and walls by mechanical means. Even the breaching of masonry walls with a battering ram and other extreme operations may be necessary. However, unnecessary destruction of buildings must be discouraged. Responsibility for careful, methodical **forcible** entry rests directly with the fire department. Forcible entry may be required for rescue, ventilation, control, or extinguishment and must be carried out with fast, methodical judgment, and tactics.

a. *Cutting with the Ax.* In cutting with a fire ax, short, quick, forceful strokes are used for better aim. Such strokes also prevent the ax from striking personnel and from catching in overhead obstructions, either of which is easily possible in dark or smoke-filled areas.

(1) Cuts are made diagonally rather than with the grain of the board (fig. 4-49) and as close to a joist or stud as possible. A proficient firefighter should be able to use the ax either right or left handed. Cutting in difficult corners **and** under obstructions can be efficiently done only by men who have been properly trained.

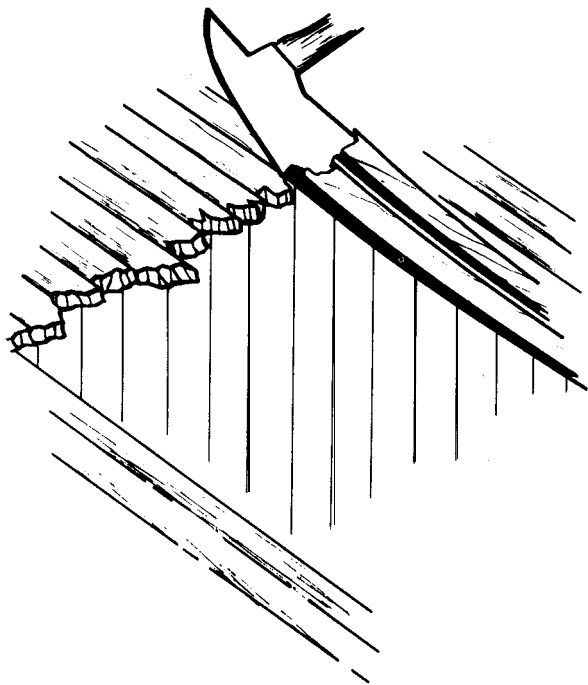

Figure 4-49. Cutting with the fire ax.

(2) Ax-made cuts in flooring, roofing, or sheathing are made at an angle of about  $60^\circ$  instead of straight down. Diagonal sheathing is cut in the direction the sheathing runs so that chips will tend to split out. If cuts are made against the sheathing, the ax may bind and require extra effort and time. Cuts through a lath-and-plaster wall are made in a direction diagonal to the grain rather than perpendicular to it. After the boards are cut, the pick end of the ax may be used for prying and removing them (fig. 4-50).

**b. Types of Doors.** The various types of doors must be understood by firemen before successful forcible entry can be made with the proper tools. The doors normally found on Army installations are ledge doors, panel doors, and industrial doors.

(1) **Ledge doors.** Ledge doors, sometimes called batten doors, are made of built-up material. These doors must be locked with surface locks consisting of hasps and padlocks, bolts, or bars. Hinges on ledge doors generally are of the surface type, fastened with screws or bolts.

(2) **Panel doors.** Panel doors may be either cross or vertically paneled. The panels are composed of thin material and dadoes are not glued into the stiles and rails. Either surface or mortised locks may be used, and hinges may have full surfaces, half surfaces, or hidden butts. The hinges usually contain loose pins, which are easily removed by a tap with an ax or a spanner wrench.

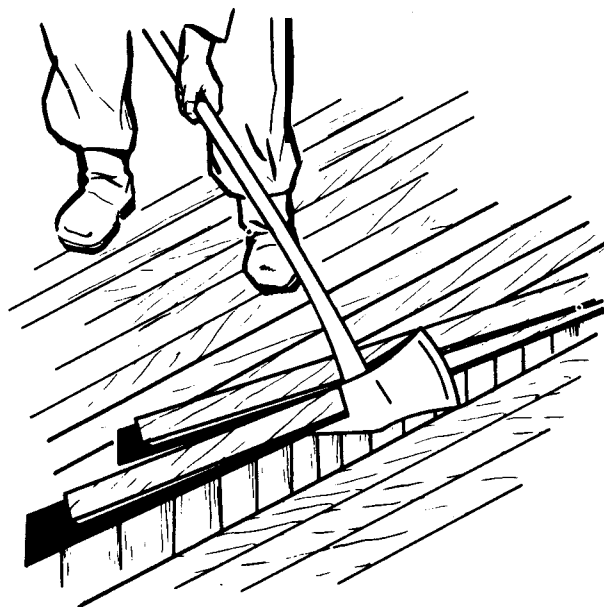

Figure 4-50. Prying with the fire ax.



Figure 4-51. Removing the hinge pins.

This avoids damaging the door or its casing (fig. 4-51).

(3) **Slab doors.** These are generally made of veneered hardwood with a white-pine core. They usually employ the same general hardware as panel doors, and, because they are solid, are not easily sprung.

(4) **Industrial doors.** Industrial doors are used in garages, warehouses, and storehouses, are double- and single-sliding, overhead-lift, or overhead-rolling.

**c. Opening Doors.** The method for opening doors is determined first by the manner in which



the door is hung on the frame and then the way it is locked. Outside doors in barracks, store buildings, and recreation halls, and smaller doors of other buildings are set either against stops in the frame or against a rabbeted shoulder in the door-jamb. When using a door opener, insert the wedge just above or below the lock (fig. 4-52). A spanner wrench with a wedge end may also be used where a great amount of leverage is not required.

(1) Overhead-rolling doors are made of steel and offer the greatest resistance to forcible-entry tools. Normally, such a door cannot be raised except by operating its gear and chain. Prying on such a door may spring it so that the gear will not function. Sometimes a cast iron plate is installed in the wall near the chain. This plate can be broken to permit reaching the chain and raising the door in an emergency.

(2) If doors are only stopped in frame, the stop can be raised with a sharp wedge and the door swung clear of its fastening (fig. 4-53). When springing a door in a stopped frame with a door opener, use the tool to separate the lock and the jamb just enough for the lock to pass the keeper.

(3) When the door is set in a rabbeted frame, entry is not easily made. However, splitting the jamb or breaking the lock bolt with the door-opening tool will allow entry (fig. 4-54). To spring a door from either the stopped frame or the rabbeted frame, push the door open inward after the opener is completely inserted.



Figure 4-52. Using the door opener.

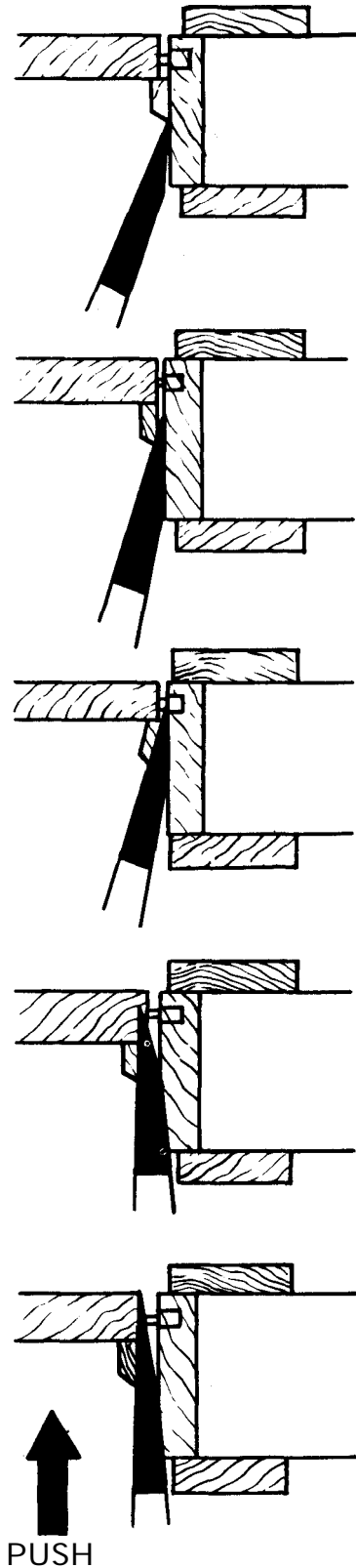

Figure 4-53. Springing a door in a stopped frame.

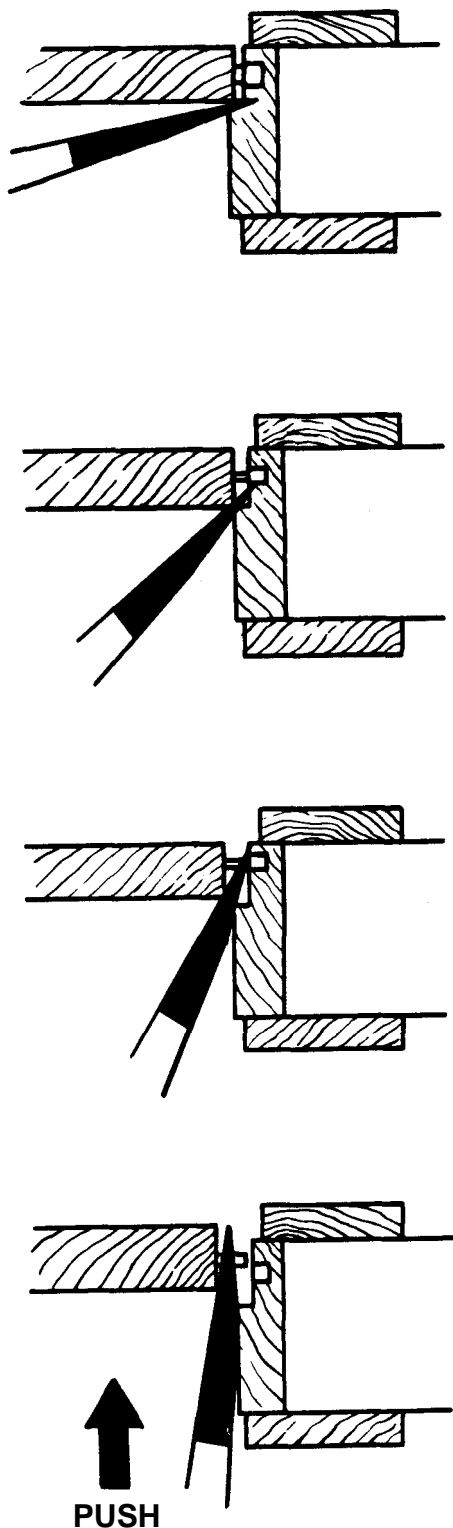

Figure 4-54. Springing a door in a rabbeted frame.

(4) The same door may be opened with the wedge of an ax by inserting the blade above or below the lock and prying it to allow the bolt to pass the keeper (fig. 4-55). If this system is used, both the door and the jamb will be slightly dam-

aged, but the door will close properly after the entry has been made.

(5) Double doors may be opened by prying between the doors until the bolt of the door clears the keeper. If an astragal, or the wooden molding, covers the opening, it must be set away before inserting the wedge.

(6) Night latches will normally yield to the same prying tactics as mortised locks. However, if

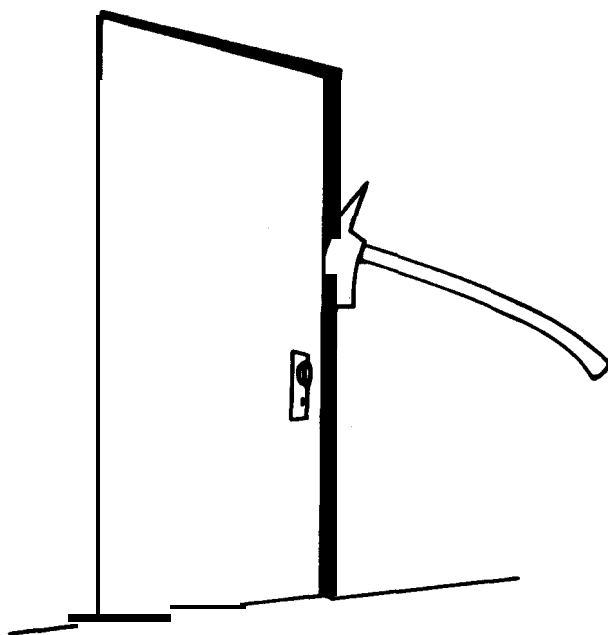

Figure 4-55. Opening a door with a fire ax.

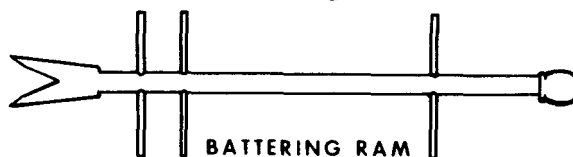

Figure 4-56. Battering ram.

they are fastened to the door with screws, they can be bumped off with a heavy **object**, such as a battering ram (fig. 4-56). When a battering ram is available, pushing a shoulder against the side of the door opposite the hinges will often spring the lock.

(7) Overhead-lift doors can be forced by prying upward at the bottom of the door with a crowbar or claw tool. After the lock bar is broken, the doors open readily.

(8) When single-hinged doors, such as those on houses and stables, are locked with a hasp and padlock, the staple of the hasp can be pried or twisted off with a door opener without damage to the lock (fig. 4-57).

(9) Many double warehouse doors are **se**cured with a bar dropped into stirrups on the inside of the wall. In these cases, forcible entry is made by battering the door down or by making a breach in the wall with a battering ram. The breach is made at a point which permits slipping the bar from the stirrups. For ordinary brick walls, battering a hole large enough for a **man** to enter and unlock the doors from the inside is **fre**quently the quickest and **le**ast destructive method of entry.

d. **Windows.** Prying with a wedge is the principal operation in forcing **windows**. The firefighter's ax, a claw tool, or any other wedge-shaped instrument may be used. If the wedge **is** wide and thin, entry can be forced with minimum damage.

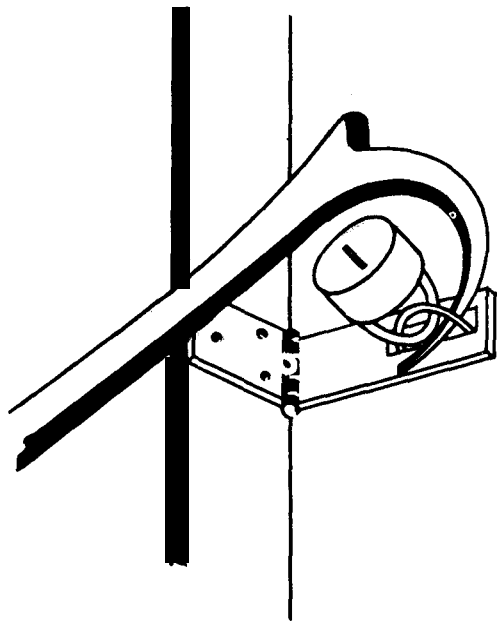

Figure 4-57. Using a door opener on a hasp.

(1) Factory type windows **consist** of steel sashes, which are often set solidly in the frame so that only a portion of the window may be opened. The movable portion is generally either pivoted at the center or hinged at the top and latched on the inside. Since factory type windows have small panes, breaking a glass near the latch becomes a **fast**, simple operation which causes negligible damage. Jagged pieces of glass left on the sash are cleared out before the hand is inserted. Wired glass must be completely removed from the sash.

(2) The check-rail window has two frames, or sashes, which are in contact at the top and bottom horizontals. If the window has no weights, the sash is locked with bolts in the window stiles or by a friction lock pressing against the window jamb (fig. 4-58).

(3) Check-rail windows can be opened by prying upward on the lower sash rail (fig. 4-59). If the window is locked on the check-rail, the screws of the lock give way, and the sashes separate. When the window is locked with spring-activated bolts, they must be broken or bent before the sash can be raised. Prying should be done at the center of the glass. However, if the check-rail

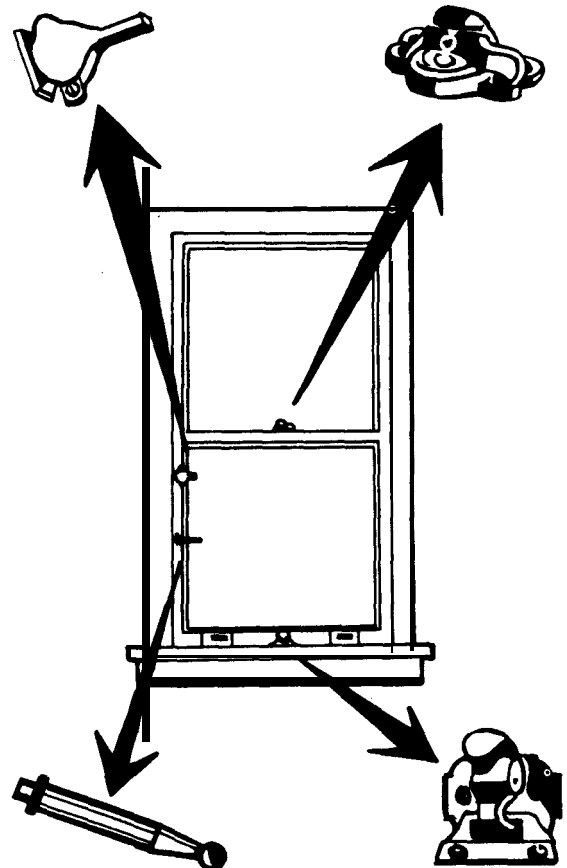

Figure 4-58. Locking devices for check-rail windows.

latch is on the side, the pry should be made directly beneath it.

(4) Basement windows may be opened in the same manner as a door in a rabbeted frame. If the prying is done at the center of the lower rail, the lock may be pulled or sprung.

(5) To open windows on upper floors, primarily to provide ventilation, the firefighter lies face down on the roof or leans from a window on the floor above and **applies** the point or hook of a pike pole to the window below (fig. 4-60). The pike pole can also be used to break the glass if the **windown** cannot be raised or lowered and ventilation is essential.

(6) Casement sashes are hinged to the window jambs and meet vertically ; they are locked either together or to the window frame. Casement windows can be opened in much the same manner as double doors. Generally, they are securely locked, and breaking the glass is necessary. Casement sashes of wood are generally hinged at the top and locked at the bottom; metal sashes may be hinged either at the bottom or at the top.

*e. Roofs.* Roofs may be classified, according to the construction of the covering, as shingle roofs, composition roofs, or metal roofs.

(1) Shingle roofs include all those made of small sections of material, such as wood, metal, or asbestos, fastened to the sheathing. Shingles are nailed to sheathing and can be removed easily. Shingle roofs can be opened by stripping off the shingles and cutting away the sheathing.

(2) Composition roofs contain from one to six sheets of roofing material, generally consisting of tarred felt nailed to the sheathing and

cemented together with asphalt. Hot asphalt that hardens when it cools is spread over the entire **covering**. Gravel may be spread into and over the hot asphalt to become a part of the covering when the asphalt cools. The sheathing consists of 1-inch (2.54-centimeter) **shiplap** laid tightly on wood joints or on solid concrete. Composition roofs require more care to open because they are more **difficult** to repair. The covering is cut and rolled back before the sheathing is cut away to make an opening. To locate joists, the roof should be sounded before it is cut. The cuts should be close to the joists to make both cutting and repair easier.

(3) Metal roofs, generally tinplate, consist of sheets of metal crimped or soldered together as one sheet. The sheets are fastened to the sheathing just as in wood construction under composition roofs. Successful ventilation frequently must be obtained by forcible entry tactics. When making an entry for ventilation, **the** firefighter should always work with the wind at his back so that gases and flames coming from the opening do not hinder or endanger him. After a roof is opened, the ceiling below is opened by forcing it down with a pike pole or other suitable tool. A ceiling is not usually difficult to push down from above.



Figure 4-59. Opening check-rail windows.

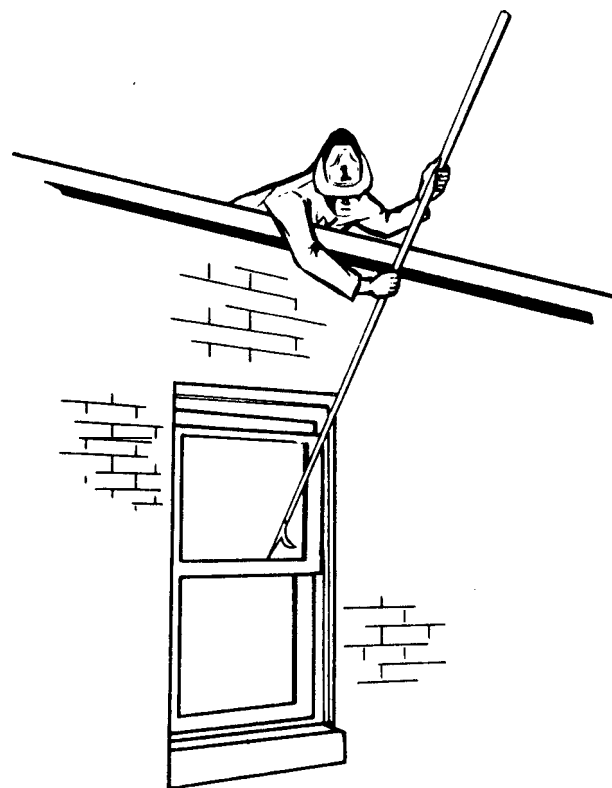

Figure 4-60. Using pike pole to open a window from above.

f. Floors. Permanent-construction wood floors are laid double on joints generally set on **16-inch (40.6-centimeter)** centers. The subfloor is usually laid on a **45°** angle to the joints, and the top or finish floor at right angles to the joists. In mobilization type buildings, a single floor is laid directly on the joists, the joists set on **16-inch (40.6-centimeter)** centers. In theater-of-operations type construction, a single floor is laid on joists on **24-inch (41-centimeter)** centers. Floors may be opened in much the same way as flat roofs, except that two distinct cutting jobs are required for double floors because the subfloor and finish floor run in different directions. Joists are located by sounding, and both cuts follow the side of the joists toward the inside of the required opening. For efficient cutting, the hand which applies the force is held halfway up the ax handle. The feet are spread for proper balance and to avoid cutting the foot by a misplaced or glancing stroke. The man doing the cutting must be careful to stand outside the area to be opened.

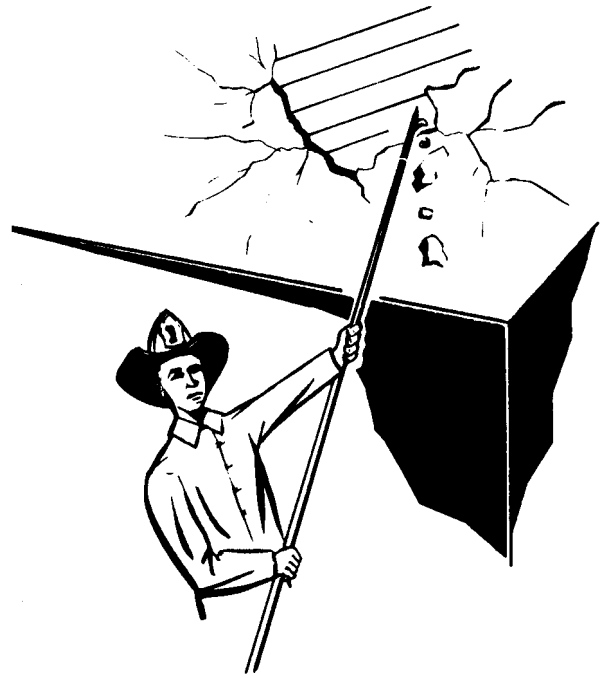

Figure 4-61. Removing lath and plaster ceiling.

g. Ceilings. Plastered ceilings are opened by breaking the plaster and pulling off the laths. A pike pole of proper length is the most effective tool for this job (fig. 4-61). Metal and composition ceilings can be pulled from joists in the same manner. Board ceilings are somewhat difficult to remove because the lumber offers considerable resistance when an attempt is made to jam the pole through or between the boards to get a solid grip on the hook.

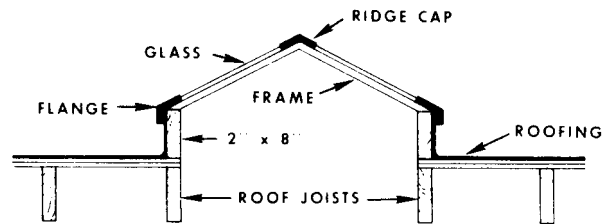

Figure 4-62. Section of a typical skylight.

**NOTE**

Certain precautions must be observed when opening ceilings and walls. Do not stand under the areas to be opened, pull downward and away to avoid being hit by falling material, and keep the upper hand on top of the pole to aid in pulling away. Always wear a helmet when pulling down a ceiling, since it is difficult to predetermine the amount of the ceiling which may fall after one thrust.

**h. Glass.**

(1) The glass panes of a skylight are generally installed in a metal frame which slips over a flanged roof opening (fig. 4-62). By prying under the edge, the entire skylight can usually be pulled loose and removed, if necessary. If skylight cannot be lifted, the glass panes may be taken out by releasing the metal strips that cover the joists and removing the putty.

(2) Glass in doors and windows is broken

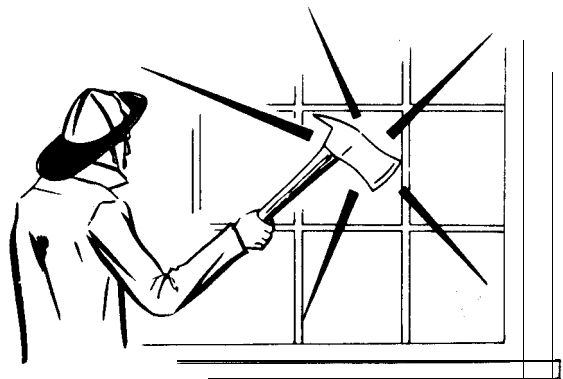

Figure 4-63. Breaking window glass with an ax.

easily with the flat side of an ax. When breaking the glass, stand to one side and strike the upper portion of the pane first, being careful that broken glass does not slide down the ax handle (fig. 4-63). After the glass is broken out, remove all jagged pieces from the sash to safeguard personnel, hose, and ropes from injury and damage.

when they pass through the opening. The jagged glass may be removed with the pick of the **ax**.

**i. Tools.** The proper way to carry tools is almost as important as knowing how to use them. Tools with sharp hooks or sharp edges should never be carried on the shoulder. If the carrier **stumbles**, he may release his grip on the tool, which may fall against him or strike another person. In the confusion, haste, and limited vision which normally accompany a fire, body contact is common, **making** an exposed tool a definite hazard. Sharp edges and points can be guarded best if tools are held in the hands. An ax, for example, is carried at about the level of the waist and held high in a horizontal position, with one hand **grasping** the handle near

the head and the other hand covering the pick. Another effective method of carrying an ax is to hold it in a vertical position, parallel to the body, with the **axhead** upward, the blade almost beneath the armpit, and the hand covering the pick. In these positions, an ax can be easily thrown away from the body in the event of a fall. Tools with hooks, such as claw tools, are carried at the side with the hook forward. All tools with pointed and sharpened edges are carried in a like manner. A sense of **safety** is important in this respect.

**j. Other Types of Construction.** Local **construction** should be studied and preplanning done when construction varies from that described in **this** paragraph.

## Section V. VENTILATION AND SALVAGE

### 4-40. Introduction

The problem of ventilation in burning buildings frequently presents great difficulties even to the experienced man. Salvage, including the prevention of excessive water damage, is another important factor in firefighting.

**a. Unless** firefighters have a technical knowledge of combustion processes, fuel characteristics, oxygen requirements, draft, effect of heat on air currents and building ventilation, and the principles involved in forcible entry, they cannot attack fires in buildings effectively and with reasonable freedom from danger. Principles of the chemistry of fires include many of the necessary facts, but ventilation **introduces** special variations. Ventilation includes removing smoke, gases, and heat from a building and controlling the fresh air supply to aid in rescues, protect the **firefighters**, and prevent the spread of fire.

**b.** The importance of salvage work done by firefighters cannot be stressed too strongly. Buildings and other combustibles are salvaged proportionately to the speed and efficiency of the firefighters and their ability to prevent water damage.

### 4-41. The Combustion Process

**In the** combustion process, fuels liberate carbon and hydrogen, the most common **elements** in burning materials.

**a.** A fuel exposed to flame or spark burns if it is heated to its ignition temperature if a sufficient amount of oxygen is present. **The** approximate ignition temperatures of the most common **struc-**

**tural** materials are as follows : dry wood, **500°F. (260°C.)**; paper, **450°F. (232°C.)**; pyroxylin **plastics**, **275°F. (135°C.)**; and cotton cloth, **440°F. (227°C.)**.

**b.** When fuels reach their ignition temperatures, they react with oxygen to form new compounds called the products of combustion. Most of this oxygen comes from the **atmosphere**, which normally contains 21 percent of oxygen. Some oxygen may be supplied by the oxygen content in cellulose materials **such as** wood, paper, and cloth. Free burning occurs when enough oxygen is **present** to consume the available fuel. For example, 1 atom of carbon (C) at its ignition temperature reacts with 2 atoms of oxygen (O) to form carbon dioxide (**CO<sub>2</sub>**).

**c.** In a closed structure, enough oxygen is present when the **fire** starts to support free burning. Hot gases rise to the ceiling; this starts a **consistent** current and forces the cooler air downward to feed the fire from the floor. If fresh air is unable to enter the room from the outside, the amount of oxygen is gradually reduced until the fuel smolders and smokes. Theoretically, it should **finally** smother out completely ; actually, however, the smoldering stage is sustained **because in most** cases the oxygen supply is never completely exhausted.

**d.** When the oxygen content of air is lowered, the rate and **nature of** combustion change: More and more of the carbon fraction reacts with simple atoms of oxygen to form carbon monoxide (CO), which, unlike carbon dioxide, is toxic and flammable. Sometimes fuels will **distill**, because of

the extreme high temperatures, and join the atmosphere as hot, flammable gases.

e. Carbon dioxide, the common product of the complete burning of carbon materials, is neither flammable nor poisonous. The fire begins to smolder as carbon dioxide replaces oxygen in atmosphere of a closed room. In air having a high carbon dioxide content, the danger to personnel is the suffocating effect caused by lack of oxygen.

f. Carbon monoxide is a product of incomplete combustion. Carbon monoxide gas is more prevalent in **unventilated** buildings because of the lack of oxygen. It is an extremely poisonous gas, and air that has a content of 0.5 percent carbon monoxide causes unconsciousness **quickly**. Air containing 12.5 to 74 percent carbon monoxide may be explosive. The ignition temperature of carbon monoxide is **1128°F. (609°C.)**. The combined toxic quality and flammability of this gas make it very dangerous.

g. Burning hydrogen combines with oxygen to form water vapor. Burning sulfur produces sulfur dioxide, an irritating suffocating gas which is not flammable ; it irritates the eyes and respiratory passages and is dangerous to breathe in **high** concentration. Nitrous fumes include several oxides produced by cellulose nitrates.

h. Although the gases of combustion are mixed with the air, they are more highly concentrated at specific levels, depending upon their densities. Taking air as 1.000, the following list of comparative densities will indicate the level at which these gases may be found : **carbon** dioxide, 1.608 ; carbon monoxide, 0.978; sulfur dioxide, 2.437; and nitrous fumes, 1.036 to 1.530.

i. Smoke is always produced when combustion is incomplete. Its density, color, and content vary with the oxygen supply, the intensity of heat, and the type of fuel being burned. Water vapor and particles of free carbon are generally found in the smoke; such fuels as pine may distill and give off dense black smoke. Oils, tar, paint, varnish, molasses, sugar, rubber, and sulfur may burn with such dense smoke that ordinary ventilation practices fail to clear the room.

j. If combustible materials are heated to extremely high temperatures in the absence of oxygen, the lighter fuel elements and compounds from the materials are distilled into fuel gases. These hot gases need 'only oxygen and a spark to burn with explosive violence. This explosivereac-

tion is known as a back draft. Actually a back draft may be defined as an explosion that occurs when a large quantity of oxygen is suddenly admitted to an interior fire. This condition is generally met when ventilation is made initially on the windward side of a burning building, especially when the wind is of high velocity and of sudden and large **volume**.

#### 4-42. Evaluation

Careful evaluation of the situation is necessary before an opening is made to ventilate closed buildings. The fire chief estimates the situation by considering the rescue requirements, type of building and contents, smoke and heat conditions, and explosive hazards. He also takes into account the weather conditions, manpower and equipment available, safety precautions, and exposed buildings nearby.

a. One-story buildings with several rooms or compartments present more hazards than a single compartment structure of the same size. When hot gases rise to the ceiling, the cooler fresh air from adjoining rooms is drawn under doors or through other openings, permitting the fire to burn longer before it begins to smolder. As the hot gases and smoke fill the entire structure, it becomes difficult to find the exact location of the fire, and proper ventilation procedures become increasingly uncertain.

b. In buildings of more than one story, hot gases and smoke rise to upper floors through elevator shafts, stairways, air-conditioning shafts, and similar conduits. Reaching the highest possible level, the gases and smoke spread over the entire floor, eventually filling the building from the top down. This condition is commonly known as mushrooming, and can create great smoke damage even from a small smoldering fire. At the same time, oxygen is supplied to the fire from incoming currents of cool air. Smoke is generally seen coming from openings in the upper floors regardless of the location of the fire.

c. Figure 4-64 shows how the **progress** of a fire in a closed room occurs in four stages :

(1) In the first stage (A) the fire burns freely. Adequate oxygen is still available in the air, and water vapor and carbon dioxide are produced, along with small quantities of carbon monoxide and sulfur dioxide. The room temperature is about **100°F. (38°C.)**.

(2) In the second stage (B) the original **pro-**

portion of 21 percent oxygen in the air is reduced to about 17 percent. Burning has slowed, and carbon monoxide production has increased. The room temperature is between 300° and 400°F. (149° to 204°C.).

(3) In the third stage (C) fire is barely visible because the oxygen has been reduced to 15 percent. Carbon monoxide is produced in increasing amounts, and free carbon and unburned fuel form dense smoke. Heat of about 700°F. (371°C.) and gases imperil personnel and produce an explosion hazard.

(4) In the fourth stage (D) the fire is smoldering, with the oxygen content at 13 percent or less. The room is completely filled with smoke and gases at a temperature of about 1,000°F. (538°C.). This intense heat distills a portion of the fuels from the combustible materials; the fuel gases mix with other gases present, adding to the

fire hazard. The danger to personnel and the probability of explosion (back draft) are extreme.

d. An idea of the intensity of the fire can be obtained from feeling the walls, doors, windows, and roof. Hot spots on walls and ceilings indicate the location of the fire or the path of the hot gases, A hot spot on the roof on a one-story building indicates the fire to be directly beneath it. A hot spot on the floor of a multistoried structure shows the line of travel of hot gases on the floor below.

e. When the method of attacking a fire is planned, the danger of an explosion from the admission of fresh air must be considered. Explosions which occur when fresh air is admitted to a smoldering fire are caused by rapid ignition of combustible material, gases, or both. Improper ventilation procedures generally lead to explosion hazards, and in some cases explosion hazards are

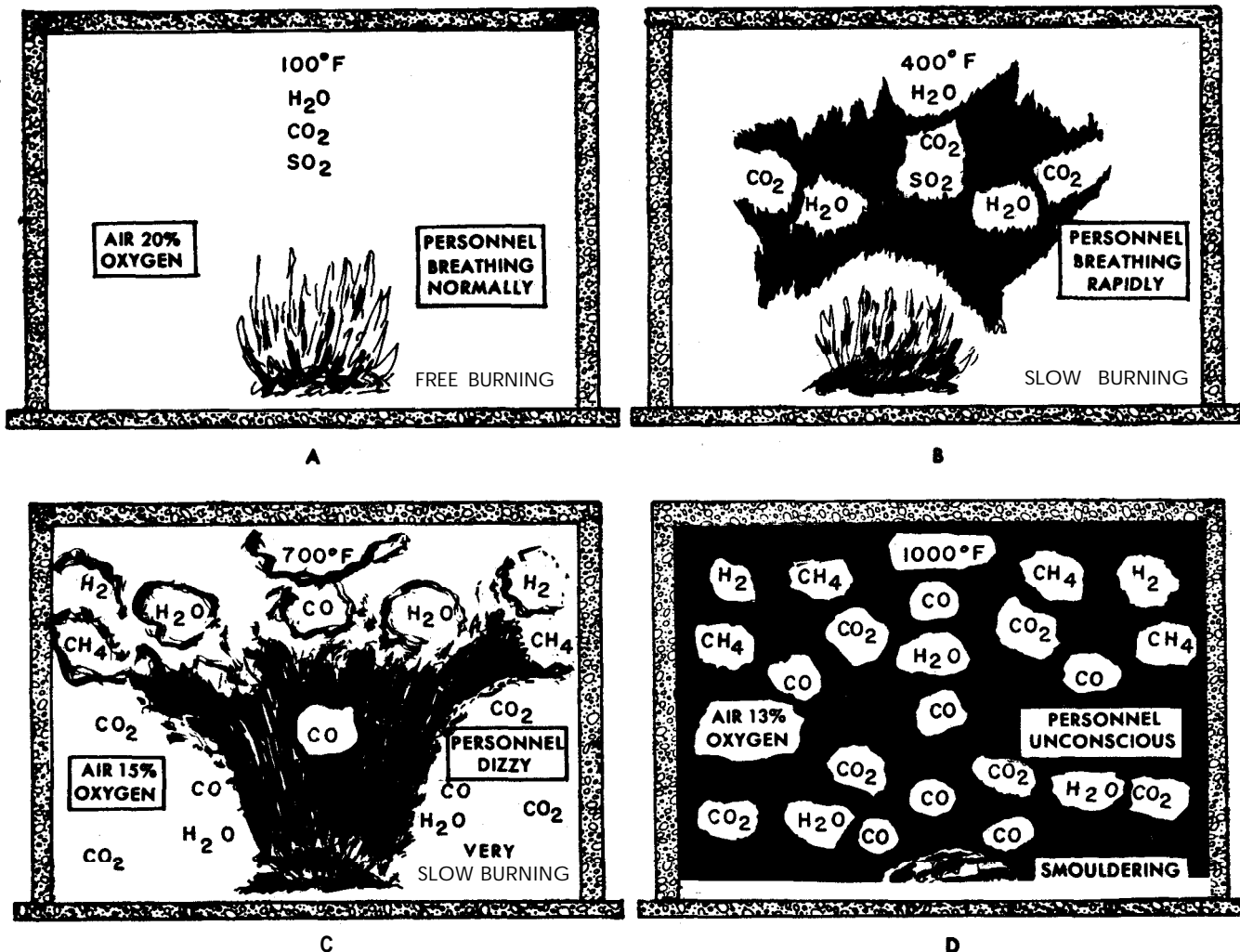

Figure 4-64. Progress of fire in a closed room.



not completely absent regardless of procedures. If the opening made for ventilation permits a sudden amount of fresh air to enter before the outward draft of fuel gases begins, an explosion will result **if** the mixture forms in proper proportions. When possible, openings should be made **above** the seat of the fire to avoid forcing a draft of fresh air directly into the fuel gases still **trapped** inside the building. Openings made near the fire, which permit large quantities of fresh air to become mixed with fuel gases before complete ignition occurs, are dangerous.

**f.** Since fire can be expected to spread rapidly as soon as an opening is made, adequate **protection** in the form of extinguishing agents must be provided, in advance, at points of intended entrance and at points of exposure to other structures. Enough charged hose lines must be advanced to extinguish the fire and provide an adequate standby reserve.

#### 443. Safety Measures

Fire protection involves so many procedures which must be executed almost simultaneously that it is difficult to present one phase without mentioning a related duty. Consequently, advancing charged hose lines to the points of entrance becomes a **significant** part of the ventilation sequence.

**a.** A combination nozzle providing either a fog or a straight stream should be **used**. The fog stream is invaluable in clearing remaining gases and laying a curtain to protect **firefighters** from the intense heat. Since carbon dioxide, carbon monoxide, and nitrous fumes are soluble, this water vapor curtain **dissolves** and carries down much of the gas ahead of the firefighters. The standby hose should be brought into use only if the fire spreads as a result of an increased oxygen **supply**.

**b.** Before the burning building is opened, protective standby lines are advanced to other buildings that may be endangered if the fire spreads. These lines are charged and ready but are not used until they are actually needed. It may be necessary to advance some of these lines over roofs and perhaps inside adjoining buildings. **Others** may be laid to support floors of the burning building if the **fire** has not yet reached them.

**c.** Precautions for the safety of the **fighters** are of primary importance during ventilating **proce-**

**dures**. Firefighters who take unnecessary **risks** not only endanger their own lives but also may handicap the department by becoming injured before the fire is extinguished. These risks, in turn, endanger the lives of others,

**d.** Air containing less than **15** percent oxygen will not sustain life, and atmosphere containing less than **17** percent **oxygen** prevents firefighters from working efficiently. Carbon monoxide and nitrous fumes in the smallest amounts may prove fatal. Compressed air, self-contained demand breathing apparatus are used where lack of oxygen is suspected.

**e.** Rope strung from the entrance to the **smoke-filled** area permits the firefighter to retrace his steps when the smoke is so thick that it permits only limited vision. After a hose is laid to the fire area, a rope becomes unnecessary, because the hose may be readily traced back to the entrance. Of sufficient importance to repeat is the necessity of using fog streams to absorb and settle **combustion** gases and disperse smoke.

#### 4-44. Ventilating the Building

After the situation at the fire has been evaluated, and the necessary preparations made, the building is opened to permit hot gases and smoke to escape and to extinguish the fire in the shortest possible time. Proper ventilation should clear the building of smoke and gases and minimize smoke damage, allow crewmen to prevent further spread of the fire, and permit the extinguishing of the fire with a minimum amount of water.

**a. Vertical Ventilation.** If the internal ventilation, or the **ventilation** of an inside compartment, of a closed building permits smoke and gas to move to the uppermost level, an opening there permits gas and smoke to escape quickly into the atmosphere. This procedure is termed vertical ventilation. The exit opening is generally made in the roof. The following procedures are important in vertical ventilation.

(1) Check the condition of the roof supports to insure that they have not been burned away or weakened to a point where they may collapse under the weight of the **firefighters**.

(2) Plan a means of escape from the roof for firefighters who may be confronted with a **possible** emergency.

(3) Use any available natural openings, such

as scuttle holes, penthouses, and skylights, if they are **properly** located.

(4) Do not permit hot combustible gases to **pass** flammable materials which are already heated. Fresh air may enter the opening before the outward current is established, thus starting a new fire on the roof.

(5) Be certain that roof openings are extended down through the ceiling of the room.

(6) Make the openings large enough to provide quick exit for smoke and gases.

(7) Work on the windward side of the openings, keeping in mind the heat, explosive characteristics, and toxic effects of escaping gas.

**b. Cross Ventilation.** If smoke **and** gases have not reached the uppermost level, cross ventilation may be used to clear the building, one floor at a time. This method requires more care than vertical ventilation because large vertical shafts, such as open stairwells, may allow downward drafts of cross-ventilated fresh air to reach an area not yet opened, causing an explosion. Natural outside openings must be available on each floor level. The procedures for cross ventilation are as follows :

(1) Open the windows on the leeward side first; then open the windows on the windward side.

(2) If the windows are check-rail types, open the upper half on the leeward side and the lower half on the windward side.

(3) After one floor is clear, ventilate the next floor in the same way, or ventilate into the room already cleared if the room is not occupied by people.

(4) Do not make openings below the level of the fire.

(5) If the opening is made at the same level as the fire, the hose lines should be available for immediate use.

#### 4-45. Entering

Before **hosemen** are directed to proceed with extinguishment, checks must be made to insure that enough heat, smoke, and gases have been removed to permit entering the building without **casualties**. When the intense draft set up at the exit openings cools or ceases altogether, the building probably is ready for entry.

a. After precautions have been taken against the spread of fire and the opening has been made

for ventilation, the next step involves reaching and extinguishing the fire. Other openings are made as near the **fire** as possible, with charged hose lines held in readiness. These openings should never be below the base of the fire.

**b.** When firefighters proceed through **smoke**-filled rooms to locate the base of the fire, they advance behind a **waterfog** curtain if the smoke causes enough discomfort to warrant its use and if water damage will not be unnecessarily great. 'This curtain tends to drive the smoke ahead of the personnel. Following the heat and smoke toward their point of greatest density is the best guide; feeling walls and fixtures and observing air currents are also helpful. The same safety and **protective** measures **must** be taken during extinguishment as are taken for ventilation.

**c.** It **may** not always be necessary to ventilate a building to locate a fire, nor is it always advisable to postpone ventilation until rescue work is completed. Actually, they go hand in hand, and when the number of available personnel is such that different **operations** can be carried on simultaneously, teamwork then takes the initiative, and hose lines are ready for use by the time the crew is **ready** to ventilate. Ventilation normally should be started at the top of the building and worked downward. Coordination in **ventilation** is an extremely important factor. When possible, it is advisable for the fire chief in charge to give the commands to ventilate. This minimizes the possibility of back draft or accelerated fire propagation, which may easily occur with several groups working without concern for each other.

**d.** A complete knowledge of such matters as the structural characteristics, arrangement, and contents of the building, acquired by previous inspections, is almost essential to successful ventilation. Basement fires are sometimes extremely difficult to ventilate because under some conditions the smoke is not hot enough to rise, which increases the possibility of explosion. **Low-temperature smoke—produced** by such materials as rubber, fats, and wax-is very persistent in resisting ventilation. Such smoke is also capable of dropping to lower levels. This condition usually requires mechanical aid, such as blowers, in addition to the normal procedures.

#### 4-46. Salvage

Salvage work in firefighting consists of <preventing excessive damage by fire, smoke, and water.

Water often causes as much damage as the fire itself.

*a. Water Protection.* Improper arrangement of contents in a structure can cause large water losses. For example, shelves built up to the ceiling directly against a wall make salvage impossible, unless the contents are removed, because water flows down the wall, soaking the shelf surfaces and their contents. One common obstacle to efficient salvage involves material piled on the floor without skids. The lower portion of such piles is difficult to salvage when a large volume of water has been used for extinguishment. Materials stored in paper boxes or cartons frequently spill when the bottoms of the containers are wet, thus ruining the entire contents even if the boxes are covered efficiently and if dikes have been made with sawdust.

(1) Material stored on lower floors may be covered with large waterproof tarpaulins. If the quantity of material and weight is not excessive, it may be moved outside or to another part of the building. Heavy crates, packing cases, machinery, and similar articles should be covered. Metal should be wiped dry and oiled to prevent rust. Much water damage can be prevented by proper application of water at the base of a fire. Firefighters should watch for leaky hose connections and for the spray of water on dry material. When the fire has been extinguished, all floors should be cleared of water by sweeping it toward a door or opening. If holes must be chopped for drainage, the rate of damage is greatly increased.

(2) Foodstuffs must be protected against becoming tainted by exposure to smoke and water. Meat, solid fats, and cheese may have little or no salvage value if they are subjected to smoke or heat.

(3) When a roof has been damaged, the hole may be covered with a tarpaulin or roofing paper. Care should be taken to remove all nails and sharp objects to prevent damage to the covers. When the entire roof is destroyed, temporary roofs of canvas truck covers may be installed. The covers must be securely fastened.

(4) Further damage by water can be prevented by using sawdust to absorb water and to form dikes that direct the water outside through doorways or other openings. Wooden floors can be drained by drilling holes in them. When absorbent materials are involved, care is necessary to prevent the excess weight added by water from collapsing the floor. Firefighters should be trained to

make a speedy estimate of the weight of water being used by calculating from the known nozzle size, the water pressure, and the length of time during which water has been discharged. A pumper discharging from a single 2½-inch (6.35-centimeter) hose line can deliver about 1 ton of water per minute.

(5) Articles of special value should be removed from the debris as soon as the fire has been extinguished. Debris should be removed from the building, floors swept, and excess water removed with broom and squeegees. Office records of administration buildings, headquarters, and similar buildings should be fully protected with canvas covers.

*b. Salvage Covers.*

(1) To permit convenient handling and easy manipulation, the 12 by 18-foot (3.7 by 5.5-meter) salvage covers are folded into an accordion fold (fig. 4-65). In this fold, the two ends are brought together in the center of the cover, which is then foiled over double. Then 10-inch (25-centimeter) folds are made until the operation is completed.

(2) The large 14 by 18-foot (4.3 by 5.5-meter) salvage cover is folded somewhat differently from the small one because of its greater

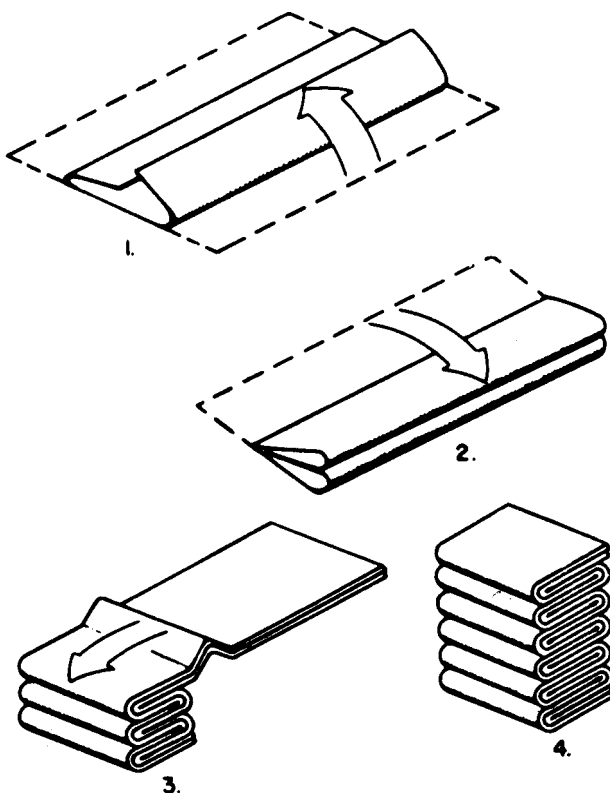

Figure 4-65. Accordion fold for small salvage covers.

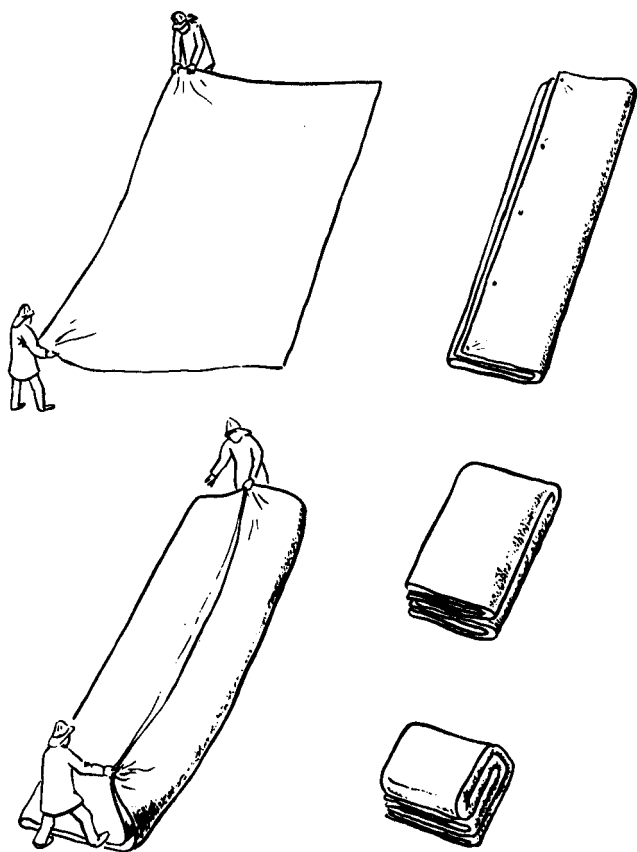

Figure 4-66 Two-man fold for large salvage cover.

size and weight. The fold for the larger cover requires two men, who position themselves at the two corners of one of the long sides of the cover (fig. 4-66). They fold the cover to the center, then fold it to the center again, bring the ends together, and fold the cover again lengthwise.

(3) The large salvage cover requires a **one-man carry** in which the cover is placed over the shoulder. This is done to keep the tops, which are secured in the grommets on the corners of the cover, to the front of the body. This enables the carrier to grasp them when the cover is to be put into use (fig. 4-67).

(4) The **one-man throw** is a quick method for spreading a 12- by 18-foot (3.7 by 5.5-meter) cover. It may be used effectively to cover desks, office records, shop machinery, and similar items. First he places the center of the folded cover over his forearm, and grasps the bottom of the fold with the fingers. Then he reaches in next to his body with the other hand and grasps the three folds between the thumb and fingers, with the thumb down. He swings his arm up and over his shoulder and flips the three folds over the back of his hand to give weight to the throw. He brings

the hand forward, with the arm still, and throws the cover over the object to be covered with a straight-arm throw. Finally he opens the cover completely and tucks the edges in at the bottom.

(6) Two men should be used to unload the 14- by 18-foot (4.3 by 5.5-meter) cover from the shoulder and place it in use. The carrier grasps the grommet ropes at the cover corners nearest his body, and the second man grasps the remaining ropes and moves away from the carrier. The cover is dropped to the ground and stretched out near the material to be covered. Both men drop the inside edge of the cover, holding firmly to the outside edges. They then raise one edge of the cover quickly, carrying it over the material and allowing the air to balloon the cover, thus enabling the proper placement of the thrown edge. All corners and edges of the cover should be tucked in at the bottom.

(6) The counter payoff is used when material must be covered to prevent its damage, destruction, or disarrangement. The counter payoff is begun by placing the cover over the forearm, holding the bottom fold with the fingers. A second man grasps the top fold and walks backward, both men raising the cover as it unfolds. They place the cover gently over the material. When the cover has been draped, they tuck in the edges at the bottom.

c. **Other Protective Devices.** The contents and interiors of buildings may be severely damaged by



Figure 4-67. Carrying and spreading the large salvage cover.

water dripping through a floor or ceiling in which a drain cannot be made.

(1) To prevent this, improvised basins are frequently needed to catch water which can be removed later by bailing, dumping, or pumping. A catch basin (fig. 4-68) is constructed by placing furniture, boxes, or other equipment in a circle or square beneath the leak. A basin is formed by placing a salvage cover over the furniture and boxes. The cover is fastened to the boxes and furniture or to the door, with the bottom of the basin resting on the floor. Where the quantity of water is not great, shallow catch basins may be made by rolling all four edges toward the center. The rolls then form the sides of the basin.

(2) S-hooks, cord, salvage covers, and pike poles can be used to build a chute which directs water through windows, thus protecting contents and interiors of buildings from water damage (fig. 4-69). Light rope or heavy cord can be tied through the grommets to support the covers.

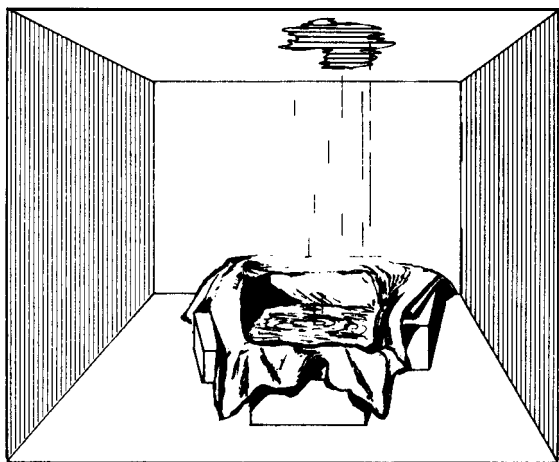

Figure 4-68. Salvage cover basin.

(3) S-hooks can be improvised from heavy wire, welding rods, or 3/16-inch (0.476-centimeter) cold-rolled steel rods. Rods can be cut to lengths of approximately 8 inches (20 centimeters), sharpened at the ends on a grinding wheel, and bent to an S-shape.

(4) To protect material stored on shelves, the shelf should be covered with the canvas salvage covers. This is done by using S-hooks, nails, and cord to suspend the covers from the walls and the ceiling or by securing the cover with weights. When more than one cover is used, lapovers of about 1 foot (0.305 meter) should be used to prevent leakage.

(5) To protect the interior structures and contents from water damage, stairway drains of canvas covers are frequently needed to direct water from upper floors to a lower level and outside. The two methods of forming stairway drains shown in figure 4-70 are commonly used. Two men and two canvas covers are required to perform the operations efficiently. The first cover is spread by the one-man throw at the bottom of the stairs and fitted to the steps. The second cover is placed at the top of the steps in the same way and is allowed to overlap the lower cover about 1 foot (0.305 meter).

(6) In addition to the tarpaulin or salvage cover, the things most commonly used in salvage work are squeegees, brooms, mops, buckets, pike poles, shovels, and sawdust. Shovels and buckets are used to remove debris. Water is removed from floors with squeegees, mops, buckets, and brooms.

d. Salvage Training. When properly executed, salvage work can often prevent great property

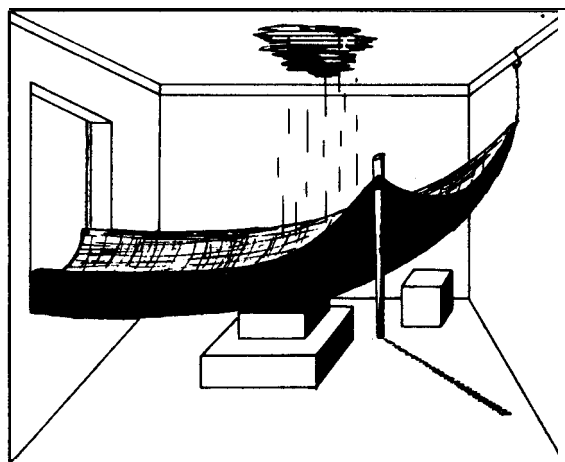

Figure 4-69. Window drain chute.

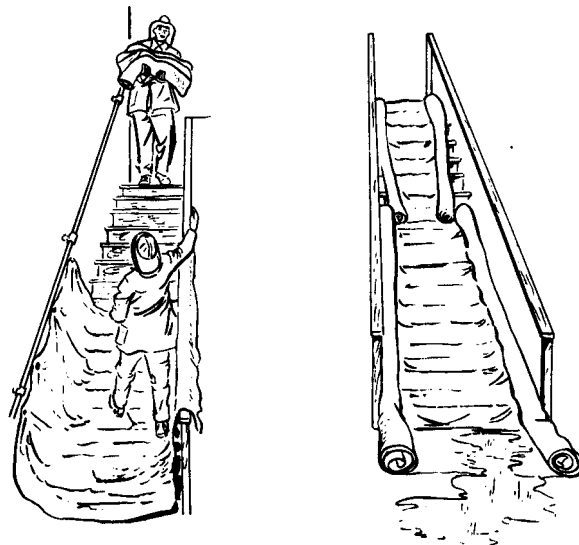

Figure 4-70. Stairway drains.

loss, and invalidate the old theory that firefighters do more damage in putting out a fire than the fire itself does. The folding, throwing, and general handling of salvage covers should be **conscientiously** practiced under varied conditions until the firefighters can do the job efficiently without hesi-

tation. For practice by two men in a coordinated handling of salvage covers, the fire apparatus itself is an ideal object over which the covers may be thrown. The erection of catch basins, plus any related operations required of the crew, may be set up as part of the salvage and pumper drills.

## Section VI. RESCUE OPERATIONS

### 447. Introduction

The primary function of rescue operations is to perform all emergency procedures that are necessary to recover personnel from situations that prohibit their escape. The first consideration of the firefighter is always that of saving lives. This function may be performed by-(1) recovering victims from hazardous situations, (2) moving victims to a safe place, and (3) giving essential **first** aid to victims. Whenever possible, the **re-**moval of victims to a safe place must be made without further injury. Extreme care must be taken in removing personnel who appear to be injured. Simple fractures, for example, may become compound fractures or may develop into more serious or even fatal injuries unless the victim is moved properly. The different ways of removing **casualties** are by supporting or carrying, by using a stretcher, and by lowering and raising victims.

### 4-48. Carries

Helping a victim walk is probably the simplest and easiest of the rescue methods, provided the victim is able to walk at all. This method should not be used unless the rescuer is sure there are no severe injuries that would be aggravated by so doing. **Two** methods are used, the one-man method and the two-man method.

a. *One-Man Supporting Carry.* To perform the one-man method, an uninjured arm of the victim is placed over the rescuer's shoulder and behind his neck. The rescuer grasps the victim's hand and passes his other arm around the victim's waist (fig. 4-71). In this way the one man may support and help a slightly injured person to walk.

b. *Two-Man Supporting Carry.* The two-man method is similar to the one-man method except that the victim puts an arm over the shoulder and behind the neck of each rescuer. Each grasps his hand and puts the other arm around his waist, **thus** giving him added support (fig. 4-72). This

way practically the entire weight of the victim can be borne by the rescuers.

### 449. Fireman's Carry

The fireman's carry (fig. 4-73) is the easiest method for one man to carry another. It is **accom-**plished in the following seven steps.



Figure 4-71. Supporting carry.



Figure 4-72. Two-man supporting carry.

a. Step 1. Turn the casualty face down and kneel on one knee at his head. Place both hands under the casualty's armpits and gradually work them down the side and across the back.

b. Step 2. Raise the casualty to the knees.

c. Step 3. Take a firm hold across the casualty's back.

d. Step 4. While holding the casualty around the waist with your right arm, grasp the casualty's right wrist with your left hand and draw his arm over your head. (If the casualty is wounded in such a way that the procedure must be performed from the opposite side, simply change the hand and continue as described, substituting right for left and vice versa.)

e. Step 5. Bend at the waist and knees and pull the casualty's right arm down over your left shoulder so that his body comes across your shoulders. At the same time, pass your right arm between his legs and grasp his right knee with your right hand.

f. Step 6. The casualty is lifted as you straighten up.

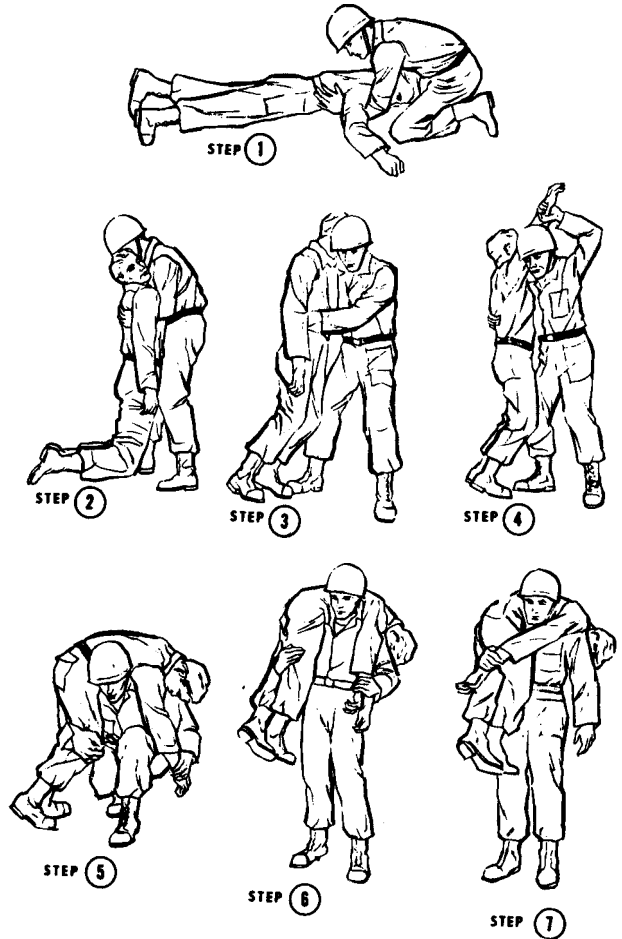

Figure 4-73. Fireman's carry.

g. Step 7'. Then grasp the casualty's right wrist with your right hand, leaving your left hand free. This is the position of carry. A man can carry another some distance in this manner.

4-50. Pack-Strap Carry

Place the pack-strap over the back and under the arms of the victim. Lift the casualty, then turn around while retaining a hold around his body with one arm. Grasp his wrists with your hands and hoist him so that his armpits are over your shoulders (fig. 4-47). This is a good way to carry an unconscious casualty. Do not use it if the casualty has any broken bones. Since both hands are

free, the rescuer may proceed down a ladder or through difficult passages. Although the dangling legs of the victim are awkward, he cannot slip from the load. Too, the rescuer can shift the load from his back to his leg muscles by bending **forward**.

#### 4-5 1. Two-Man Carriers

a. The seat carry is a two-man means of carrying a person. It consists of making a seat rest of one pair of arms and a back rest of the other pair. Figure 4-75 shows how the arms are arranged when completed. The rescuers kneel, one on either side of the victim, near the hips, and raise him to a sitting position steadying him with the arm **nearest** his head around his back. Each then slips the other arm under the victim's thighs, clasping the wrist of the other. Both arise slowly but in unison, lifting the victim from the ground. When erect, they adjust their upper arms to form a **comfortable** back rest and to make the victim



Figure 4-74. Pack-strap carry.



Figure 4-75. Arm seat rest.

secure. If conscious, the victim assists the **rescuers** by grasping each man around the neck.

b. Carrying by the extremities is a good method for carrying a person, but not usable in case of leg or back injuries. The victim is laid straight on his back, feet apart. One rescuer takes his place between the victim's legs and the other at his head, facing each other. Both men kneel and raise the victim's head and shoulders to a sitting position. The man at the victim's head grasps him from behind, around the **body** under the armpits. The one between the victim's legs turns around and passes his hands from the outside under the victim's knees, then both rise together and move forward in step (fig. 4-76).

c. A two-man chair-litter carry may be used if a common chair is available. The two men place the victim on the chair, then with one in front and one behind, they grasp the chair conveniently, tip it back, and walk forward in unison, as shown in figure 4-77. The chair serves as a litter.





Figure 4-76. Extremities carry.



Figure 4-77. Chair-litter carry.

#### 4-52. Severe Injuries Carry

In cases of severe injuries the number of rescuers should be increased to at least three. This makes it **possible** to transport the victim with the least possible bending or twisting of his body.

a. To make the carry more effective, all efforts should be coordinated, and to do so, one of the group must be in command. **The** common practice is to make the one at the victim's head commander or leader of the crew. This applies especially to a three-man crew.

b. The three-man carry is accomplished as follows: The three men line up on one side of the victim and the leader gives the word to "prepare to lift." Each man kneels on the knee nearest the victim's feet, with one man at his shoulders, one at his hips, and one at his knees. Without further orders, they pass their hands and forearms under the victim (A, fig. 4-78). The one at the head places his hands under the victim's neck and **shoulders**, the next places his hands under the pelvis and hips and small of the back, and the third under the knees and ankles. At the command "Lift," they raise the victim and place him on their knees, but without releasing their hands (B, fig. 4-78).

c. At the command "Prepare to raise," they slowly turn the victim on his side toward them until he rests in the bend of the elbows. At the command "Rise," all rise slowly to standing position, holding the patient closely against their chests (C, fig. 4-78). If space permits, the rescuers may move forward at the command "**March,**" starting off with the left foot. If space will not permit moving forward, they must move sidewise, in which case the command, "Side step left (or right)" is given. The rescuers step off with the foot according to the command, bring the other foot up to it in even, short steps. The victim is lowered and placed by reversing the operations, always at the command of the leader.

#### 4-53. Lowering and Raising a Victim

In situations where the victim is not at ground level and the natural exits are blocked, he must be rescued by some other means of escape. In fire rescues, this usually involves lowering the victim, although in rare cases it might involve raising him.

a. The escape method commonly used by the rescue squad of the fire service is by a ladder

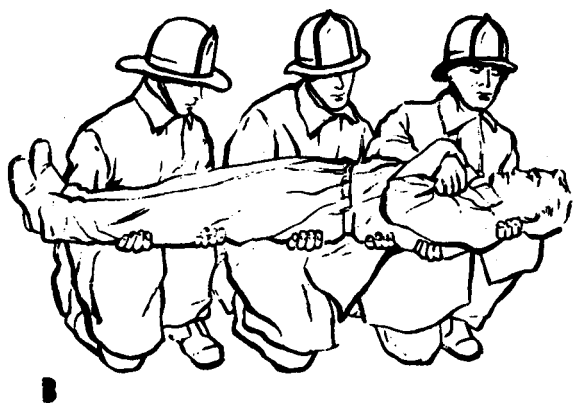
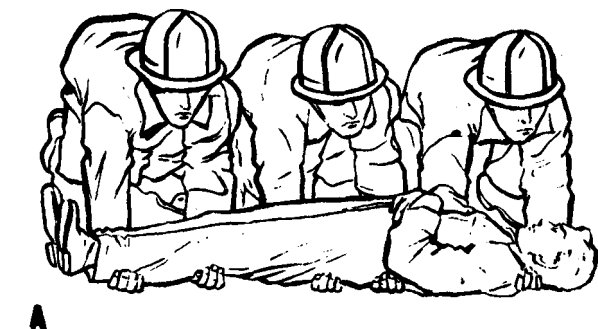

Figure 4-78. Severe injuries carry.



Figure 4-78. Lowering victim on ladder.



Figure 4-80. Lowering victim with rope and ladder.

from the outside. If the victim is conscious and uninjured, he may be guided down a ladder at a window or other opening as shown in figure 4-79. Generally a victim is **unaccustomed** to going down a ladder, especially under emergency circumstances, so great care must be taken to make sure that he does not fall. The rescuer goes down below the victim, keeping his arms around him and one knee between the victim's legs to assure a support in case he becomes unconscious.

b. Should the victim become unconscious, the rescuer lets him slip down astride his knee and proceeds carefully to the ground. If the victim is unconscious or not too seriously injured, he may be carried down the ladder by the pack-strap method.

c. An unconscious victim may be lowered from an upper floor by the use of a ladder and lifeline. (A small **handline** is not safe for this practice). Although it may appear slow compared to carrying him down a ladder, the method **may** be a safer one in certain conditions.

d. The procedure is as follows. A ladder is raised to a point just **above** the window where the rescue is to be made. The first man takes the end of the lifeline at the bottom of the ladder and passes it underneath the bottom rung. The end is

then held in either hand so that the rope will **feed** to the under side of the ladder as he ascends. When the bottom of the window sill is reached, the rope is then threaded back through the rungs, **up and over** three consecutive rungs. This allows the rope to hang freely but not too close to the building. Enough rope is then fed through, aided by the men on the ground, to allow a **sufficient** length to be taken through the window where the tie is made. Usually about 20 feet (6 meters) is enough for this operation. The rescuer then steps from his ladder through the window into the room and makes the tie on the victim. After the tie has been made, the victim is swung from the window and lowered by the men on the ground holding the rope tight (fig. 4-80).

## Section VII. FIRST AID

### 4-54. Definition and Requirements

First aid is the immediate and temporary care given to casualties before they can be treated by professional medical personnel. The firefighter is confronted mainly with cases of bleeding, respiratory deficiencies, shock, fractures, burns, and wounds. In all cases, the **uninjured** must be assured of the competency of those **administering** first aid. The victim must be kept lying down and warm with a blanket under him (if possible without danger of injury), and as comfortable as possible.

### 4-55. Short Distance Transfer

If the victim must be moved to safety, he should be pulled in the direction of the long axis of his body, not sideways. The danger is less if a blanket or similar object can be placed beneath him **so** that he can be dragged with the blanket. If a person must be lifted to safety before a check for injuries can be made, the carriers **should** try to protect all parts of the body from the tensions of lifting, as discussed in paragraphs 4-47, and 4-52.

### 4-56. External Bleeding

Severe bleeding (hemorrhage) may cause **death** within minutes; therefore, it requires **immediate attention**. It causes shock, the degree of which depends on the severity of the injury and **on the** temperament of the injured. Most bleeding can be stopped by applying direct pressure over the wound. Some wounds may require pressure on the

vessel which supplies the blood to the part of the body that is injured.

a. **Direct Pressure.** Place an opened first-aid dressing over the wound and press down (fig. 4-81). The pressure compresses the blood vessels. This reduces the blood flow and it also helps to hold blood in the wound until it clots. An additional measure which aids in controlling bleeding from an arm or leg is to elevate the injured limb higher than the rest of the body.

#### CAUTION

If there is a suspected fracture of an arm or leg do not raise the injured limb until it has been properly splinted.

b. **Digital Pressure.** It may be necessary at times to apply pressure to the supplying blood vessel to reduce bleeding. If blood is spurting

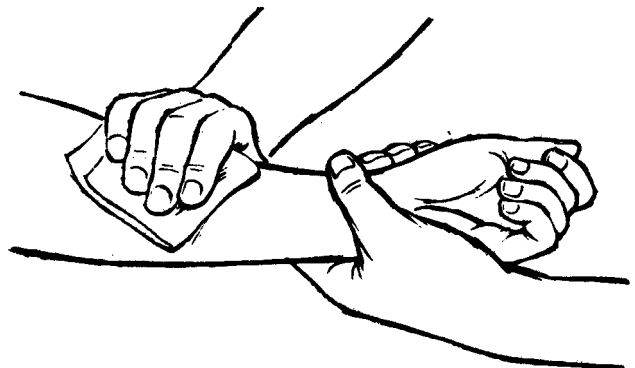

Figure 4-81. Stopping bleeding by direct pressure on the wound.

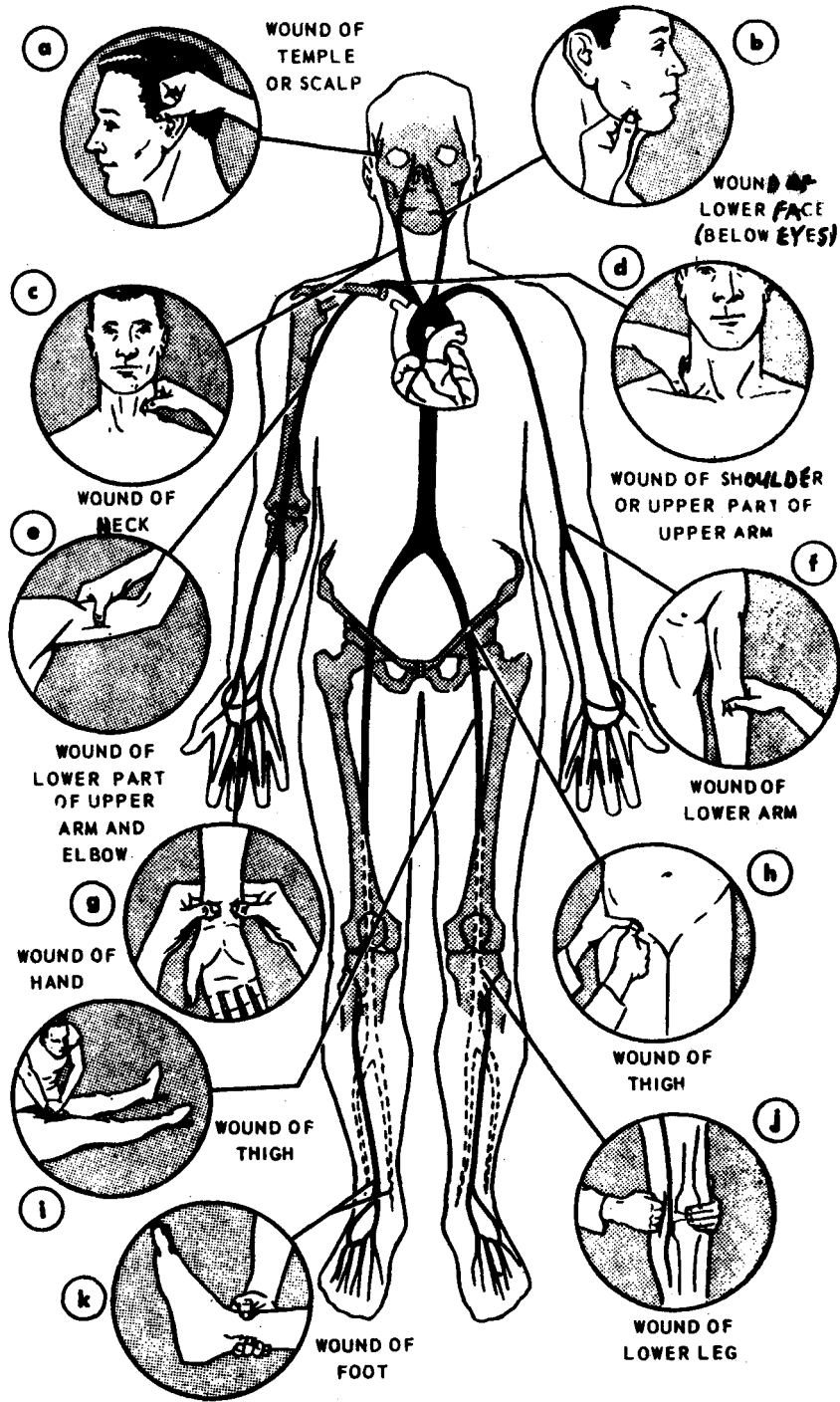

Figure 4-82. Pressure points from temporary control of arterial bleeding.

from a wound (arterial bleeding), digital pressure can be used to control the bleeding until a pressure dressing can be unwrapped and applied. Digital pressure is applied with the fingers, the thumbs, or the hands to a pressure point (fig. 4-82). A pressure point is the site at which a main artery supplying the wounded area lies near the skin and over a bone. By pressing on this point the flow of blood from the heart to the

wound is shut off or at least slowed down. The two most essential pressure points to know are e and h on figure 4-82. These are the main points by which bleeding from the extremities can be controlled.

*c. Tourniquet.* A tourniquet is a band placed around an arm or leg so tightly that the compression Hocks the arteries. It should be used *only* if pressure over the wound and elevation or pressure

on the supplying blood vessels fail to control the bleeding. A tourniquet does not stop all bleeding immediately. When a tourniquet is needed it must be applied promptly and properly.

(1) If a regular issue tourniquet is used, the buckle should be adjusted as shown in figure 4-83, and the strap pulled downward while the injured part is steadied. If an issue tourniquet is not available, a belt, tie, rope, or handkerchief is used instead of the strap. These improvised bands are tied around the arm or leg and twisted with a stick as shown in figure 4-84. A tourniquet must be drawn up tightly.

(2) For bleeding from the arm or leg, never apply a tourniquet over a bony part such as wrist, elbow, ankle, or knee. It is more efficient when applied over fleshy parts such as the thigh or upper arm. The tourniquet should be applied as close as possible to the edge of the wound.

(3) Once the tourniquet has been **applied**, the wounded man should be seen by a doctor as soon **as** possible. The tourniquet should not be loosened by anyone except medical personnel. When a tourniquet has been applied to a casualty, the time of application should be written on or near the tourniquet.

#### 4-57. Internal Bleeding

If the victim is bleeding from the mouth or nose, the blood is probably coming from the lungs, stomach, or within the skull, or passages related thereto. If the victim has trouble breathing, raise the head and shoulders, using pillows or substitutes. Try to control his vomiting. Give no stimulants or water. If unconscious, turn the victim on his side with head and chest lower than the hips. This prevents the victim from drawing blood into

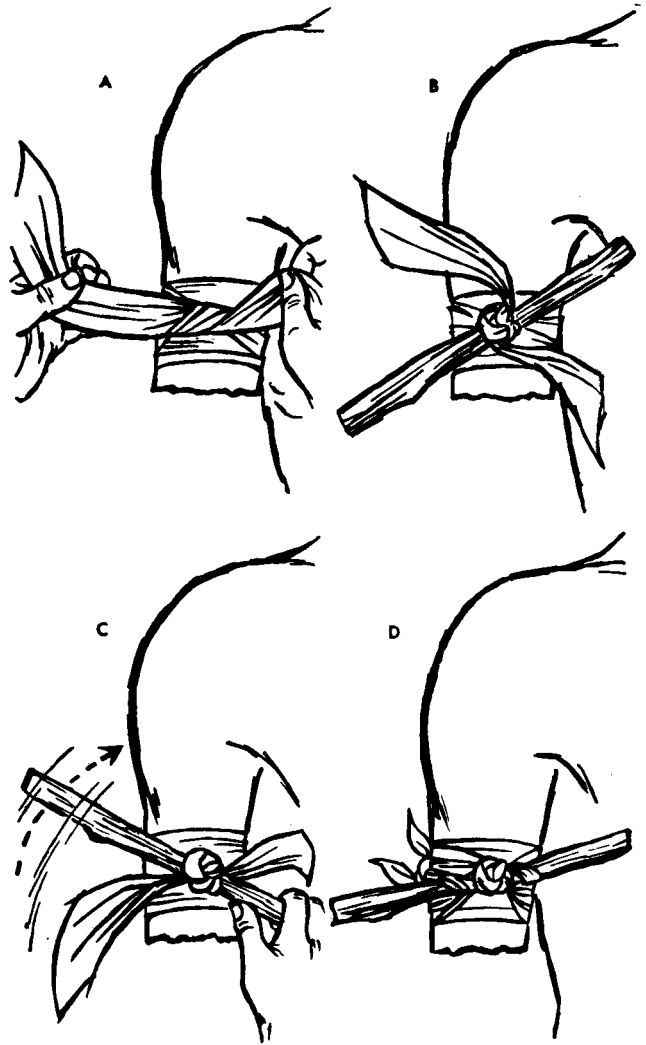

- A. WRAP TWICE AROUND ARM, TIE HALF - KNOT.
- B. PLACE 'WINDLASS' OVER HALF KNOT.
- C. FINISH KNOT AND TURN WINDLASS TOTIGHTEN.
- D. SECURE WINDLASS WITH TAILS OF TOURNIQUET.

Figure 4-84. Application of an improvised tourniquet.

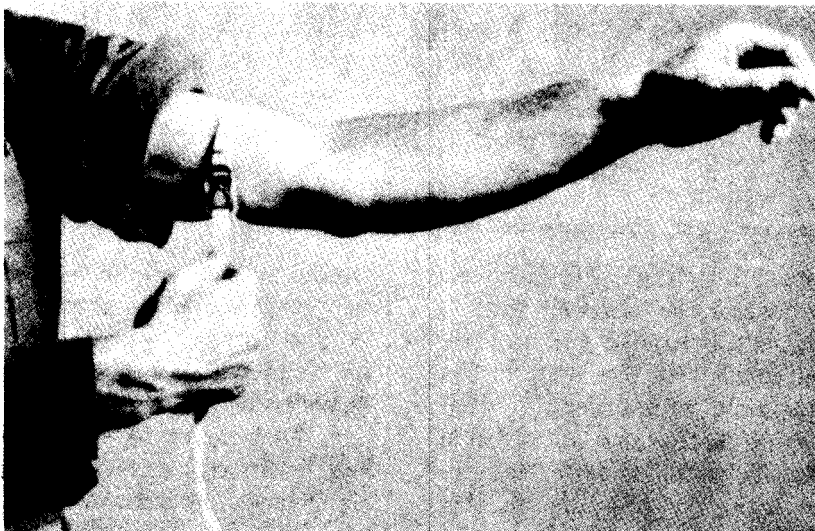

Figure 4-88. Application of a regular issue tourniquet.

the lungs while breathing. Obtain medical care **immediately**.

#### 4-58. Artificial Respiration

a. Knowledge of artificial respiration is essential to firefighters. Large fires sometimes trap people in smokefilled buildings. Then, too, firefighters are themselves likely victims of smoke inhalation. Thus, it becomes the duty of firefighters to know and apply artificial respiration.

b. Artificial respiration is administered to **non-breathing** victims of electric shock, drowning, gas poisoning, poisoning by respiration-depressing drugs (**morphine**, opium, barbiturates, and **alcohol**), compression of the chest caused by building collapse or cave-ins, choking and strangling, and partial obstruction of the breathing passages. Artificial respiration must be started promptly after normal respiration ceases. Most persons die in approximately six minutes after breathing stops unless artificial respiration is administered.

c. Artificial respiration may be administered by manual or mechanical methods. When the manual method is necessary, it may be the **mouth-to-mouth** method, back-pressure arm lift method, or the back-pressure hip-lift method. In performing any method of artificial respiration, always keep the following general principles in mind.

(1) Time is of prime importance. Do not delay artificial respiration to loosen clothing, to warm the casualty, or to give stimulants. Most important is to get air into the casualty's lungs.

(2) Quickly sweep your **fingers** through the casualty's mouth to clear out froth and debris, and draw his tongue forward.

(3) Position the casualty properly in order to maintain an open airway. Tilt his head **as** far back as possible so that the front of the neck is stretched with the chin in a "jutting-out" position. Do not allow the chin to sag.

(4) Begin artificial respiration and continue it, without interruption, until the casualty starts natural breathing or is pronounced dead. A smooth rhythm is desirable, but split second timing is not essential.

(5) If the casualty begins to breathe on his own, adjust your timing to assist him. Do not fight his attempts to breathe. Synchronize your efforts with his.

(6) As soon as the casualty is breathing for himself, or when additional help becomes available, see that his clothing **is** loosened (or removed if wet) and that he is kept warm, and is being treated for shock.

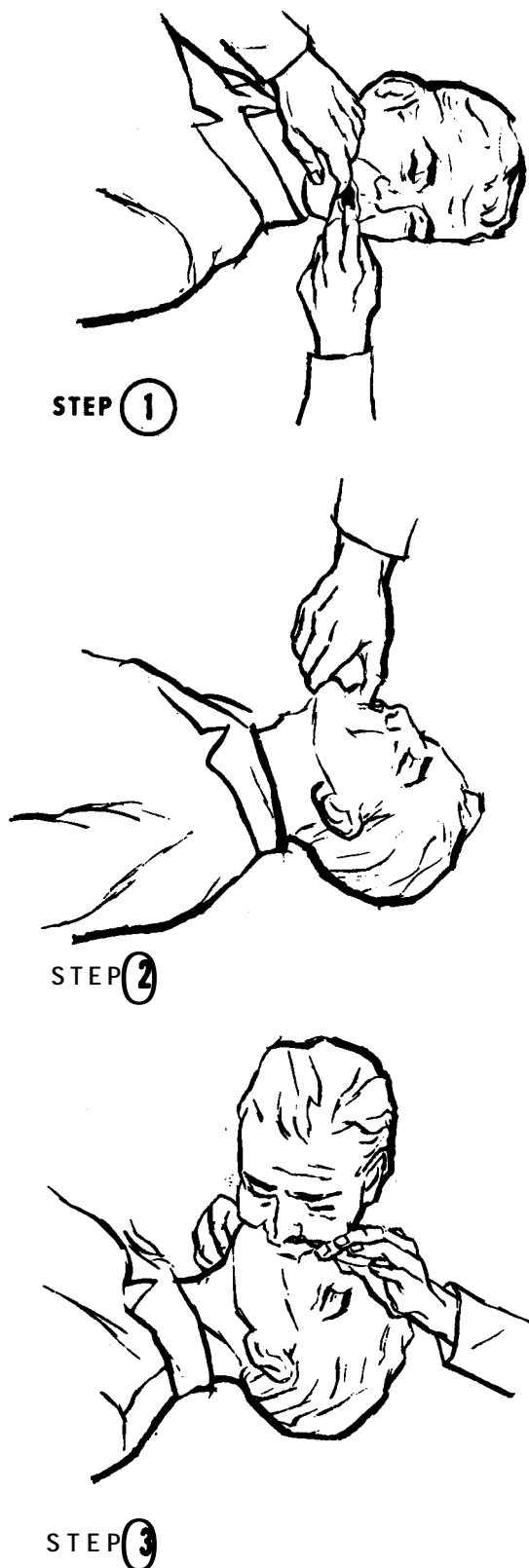

Figure 4-35. Mouth-to-mouth (thumb-jaw-lift) resuscitation method.

#### 4-59. Mouth-to-Mouth (Thumb-Jaw-lift) Method

a. Place the casualty on his back (face up). **Do not** put anything under his head because it may flex the neck and **cause** the air passages to be blocked.

b. Quickly clear his mouth of any foreign matter by running your fingers behind his lower teeth **and** over the back of his tongue (fig. 4-85). Wipe out any fluid, vomitus, or mucus.

c. If available, place a rolled blanket or some other similar material under the shoulders so that the head will drop backward. Tilt his head back so that the neck is stretched and the head is in the "chin-up" position (fig. 4-85). This **aligns** the air passages so that they do not become blocked by kinking or pressure.

d. Place your thumb into the corner of his mouth and grasp the lower jaw firmly. Lift the lower jaw forward and pull the tongue forward out of the air passage. Do not attempt to hold the tongue. Close his nostrils with the thumb and index finger (step ③, fig. 4-85). Put a cloth over the victim's mouth or nose and breathe through it if you do not wish to come in contact with the person.

e. Take a deep breath. Open your mouth wide. Then seal your mouth around the casualty's mouth and your thumb, and blow forcefully (except for infants and small children) into his mouth until you see his chest rise. If the chest does not rise, hold the jaw up more forcefully and blow harder while making sure there is no blockage of the air passage and no air leakage around the mouth or nose.

f. When his chest rises, stop blowing and quickly remove your mouth from his. Take another deep breath while listening for his exhalation. (If his exhalation is noisy, elevate the jaw **further**.)

g. When exhalation is **finished**, blow in the next deep breath. The first **5** to 10 breaths must be kept (except for infants and small **children**) and given at a rapid rate in order to provide rapid reoxygenation. Thereafter, continue breathing at a rate of 12 to 20 times a minute until the casualty begins to breathe normally. Excessively deep and rapid breathing **may** cause you to become faint and even lose consciousness.

h. After performing rescue breathing for a time, you may notice that the casualty's stomach is bulging. The bulging is due to air being blown

into the stomach instead of the lungs. Although an inflation of the **stomach** is not dangerous, it makes inflation of the lungs more difficult. Therefore, when you see the stomach bulging to a **marked** degree, apply gentle pressure to the stomach with your hand between inflations.

i. Remember: keep the air passages as clear of fluid and other obstructions as possible. Several sharp slaps between the shoulder blades usually dislodge foreign matter. Keep the head back, the neck stretched, and the chin pulled forward; readjust **position** if air does not flow freely in and out of casualty. Do not breathe too forcibly or too large a **volume** if casualty is an infant or small **child**; in infants seal both the mouth and the nose with your mouth and blow with small puffs of air from the cheeks, rather than blowing from the lungs. If **you** become distressed as a result of the shallow breaths, interrupt the blowing long enough to take a deep breath, then resume blowing.

#### 4-60. Mouth-to-Mouth (Two-Hands-Jaw-lift) Method

This is an alternate method for use in a clean atmosphere when the casualty's jaws are so tightly closed that the thumb cannot be inserted.

a. Place the casualty on his back, clear his mouth if possible, and position his head in the "chin-up" position.

b. Grasp the angles of his lower jaw with both hands just **below** the ear lobes and lift the jaw forcibly forward to pull the tongue forward out of the air passage. If the lips are closed, push the lower lip toward the chin with **your** thumbs (fig. 4-86).

c. Take a deep breath and open your mouth wide. Seal your mouth around the casualty's mouth, press **your** cheek against his nose to prevent air leakage and blow forcibly into his mouth until you see his chest rise.

#### 4-61. Mouth-to-Nose Method

This is an alternate method for use in a clean atmosphere when neither of the methods above can be used; for example, on casualties with severe jaw spasm or with wounds of the jaw and **mouth**,

a. Place the casualty on his back, clear his mouth if possible, and position his head in the "chin-up" position. Grasp the angle of his lower

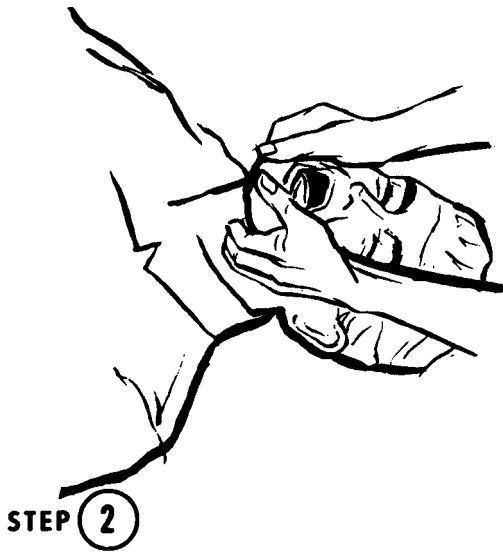
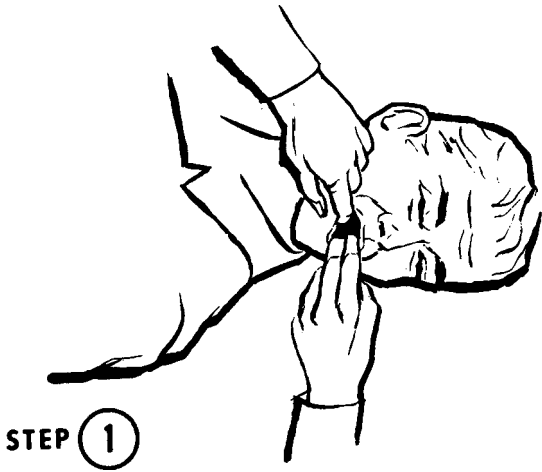

Figure 4-86. Mouth-to-mouth (two-hands-jaw-lift) resuscitation method.

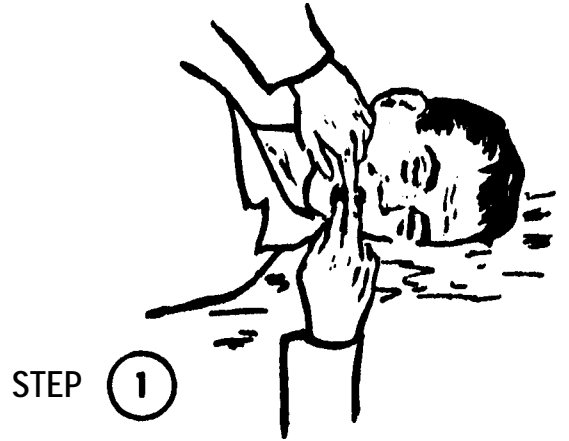

Figure 4-87. Mouth-to-nose resuscitation method.



jaw with one hand just below the ear lobe and lift the jaw forcibly forward (fig. 4-87).

b. Seal your other hand over the casualty's mouth to prevent air leakage (fig. 4-87).

c. Take a deep breath and open your mouth wide. Seal your mouth around the casualty's nose (fig. 4-87), and blow forcefully until you see his chest rise.

d. When his chest rises, stop blowing and quickly remove your mouth from his nose. Take another breath while listening for his exhalation.

#### 4-62. Chest-Pressure Arm-lift Method (Modified Silvester)

This is the preferred method for use in a contaminated atmosphere.

a. Place the casualty on his back (face up) with his arms folded on his chest (fig. 4-88).

b. Quickly clear his mouth of any foreign matter by running your fingers behind his lower teeth and over the back of his tongue. Wipe out any fluid, vomitus, or mucus. If you are in a contaminated area and the casualty is not already masked, put his mask on. If he is already masked, quickly remove the mask, wipe away any fluids that may have collected in his mouth or in his mask, and replace the mask.

c. If available, place a rolled blanket or some other similar material under the shoulders so that the head will drop backward. Tilt his head back so that the neck is stretched and the head is in the "chin-up" position. If possible, keep the head in this position, since this aligns the air passages so that they do not become blocked by kinking or pressure.

d. Kneel on either knee at the casualty's head, placing your knee at one side of his head, and placing your opposite foot on the other side of his head.

e. Take the casualty's arms just above his wrists and place them over the lower ribs. Rock forward and exert steady, uniform pressure almost directly downward until you meet firm resistance. This pressure forces air out of the lungs.

f. Immediately release this pressure and pull the arms outward and upward over his head and backward as far as possible (③, fig. 4-88). Lifting and stretching of the arms increases the chest size and draws air into the lungs.

g. Slowly replace his arms on his chest and

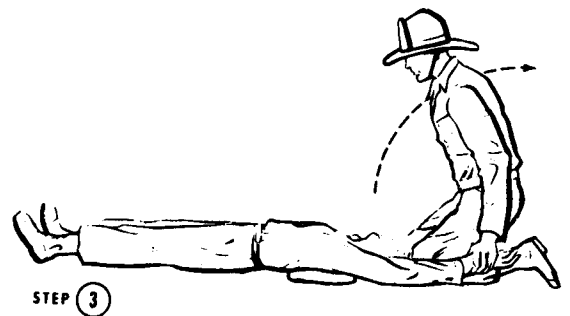
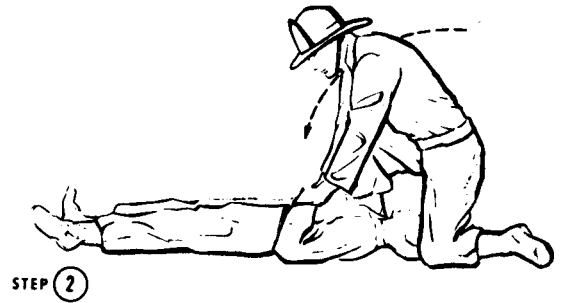
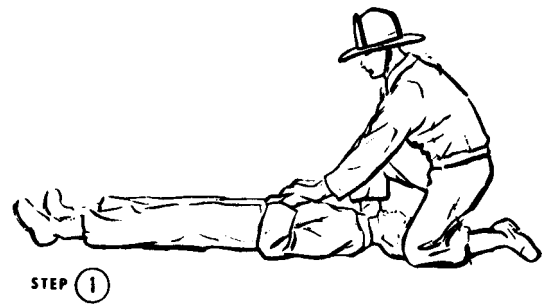

Figure 4-88. Chest-pressure arm-lift resuscitation method

repeat the complete cycle about 12 times per minute at a rhythm of (1) press—(2) lift—(3) stretch—(4) release. The "release" should be abrupt.

h. If you become tired or uncomfortable on one knee, you may quickly switch to the other knee. If it is more comfortable, you may kneel on both knees, although the forward and backward motion is easier to obtain while kneeling on one knee only.

i. Check the mouth frequently for obstructions. If vomitus, mucus, or blood obstruct the air passage, keep the victim's head extended and turned to one side.

j. When a second man is available, he may take over the chest-pressure arm-lift with practically no break in the rhythm. This is done by the first man moving off to one side while the replacement

comes in from the other side. When the second man is ready, the casualty's arms are released during the "stretch" and the new operator takes them and continues in the same rhythm.

#### 4-63. Followup Care in Artificial Respiration

When the casualty is breathing normally, wrap him in a blanket. He should remain lying down until he is seen by a physician or his recovery seems assured. When he is conscious, give him a warm drink, such as coffee or tea.

#### 4-64. Shock

Although there are several types of shock, the one with which the firefighter is chiefly concerned is traumatic shock. This is a depressed condition of many of the body functions. It is caused by failure of enough blood to circulate through the body following a serious injury. Traumatic shock may result from injury to body tissues from burns, wounds, or fractures. In most instances it is the result of the loss of large quantities of blood either externally or into the tissues of body cavities. In general, the greater the damage to flesh and bone and the more loss of blood, the greater the danger that shock will occur. Victims of shock must be handled with great care; rough handling may have fatal results. Any seriously injured victim is susceptible to shock and must be handled accordingly.

a. *Symptoms of Shock.* The most important evidence of shock is the victim's weakness coupled with pale skin which is moist and cooler than normal.

(1) Beads of perspiration may be noted about the victim's lips, forehead, palms, and armpits. He may vomit or complain of nausea. His mental reactions may appear normal at first, but he will later lose his alertness and interest in his surroundings. He will most likely be thirsty.

(2) The pulse of a shock victim is rapid but may be weak and difficult to detect. Breathing is faster than usual with occasional deep breaths. In case of severe hemorrhage, these signs may not be evident at first but may develop after an hour or more. *Where there is doubt, give first-aid treatment for shock.*

b. *Treatment.* The same first-aid treatment should be used for both prevention and care of shock.

(1) Keep the victim lying down. This permits a greater amount of blood to flow to the head and

chest. It is also the most favorable position if there is injury to the internal organs or the head, or when there is evidence of fracture. If the victim has difficulty in breathing, his head and shoulders should be elevated. If there is no difficulty in breathing and there are no head injuries, the lower part of his body should be elevated to aid the flow of blood to the head and chest.

(2) Place a blanket beneath the victim and if necessary cover him with another. Keep him warm but just warm enough to be comfortable. Never use hot-water bottles or heating pads except in very cold weather, and then with care.

(3) The overall principle of applying heat to a shock victim is: do not add heat; simply prevent the loss of body heat.

(4) If the victim is conscious and there is no sign of nausea or stomach hemorrhage, a few sips of water may be given to him. If there is a delay in obtaining medical service,  $\frac{1}{2}$  glass of water (with  $\frac{1}{2}$  teaspoon of table salt and  $\frac{1}{2}$  teaspoon of baking soda per quart (0.946 liter) of water), given at X-minute interval, is recommended when fluids may be given. Stimulants, such as ammonia or coffee, have no value in treating traumatic shock.

(5) Do not forget to give attention to the injuries of a shock victim. Also comfort and encourage him.

#### 4-65. Electric Shock

a. Electric shock accidents frequently result from contact with a "live" wire and occasionally occur when a person is struck by lightning.

b. If a person has come in contact with an electric current, turn off the switch if it is nearby, but do not waste time looking for it. Use a dry wooden pole, dry clothing, dry rope, or some other material which will not conduct electricity to remove the person from a live wire (fig. 4-89). Do not touch the wire or the casualty with your bare hands.

c. Electric shock causes breathing to stop, so start artificial respiration immediately after freeing the person from the wire.

#### 4-66. Fractures

Fractures (broken bones) are either simple or compound fractures (fig. 4-90). A simple fracture is also called a closed fracture because the broken bone has not pierced the skin and is causing no

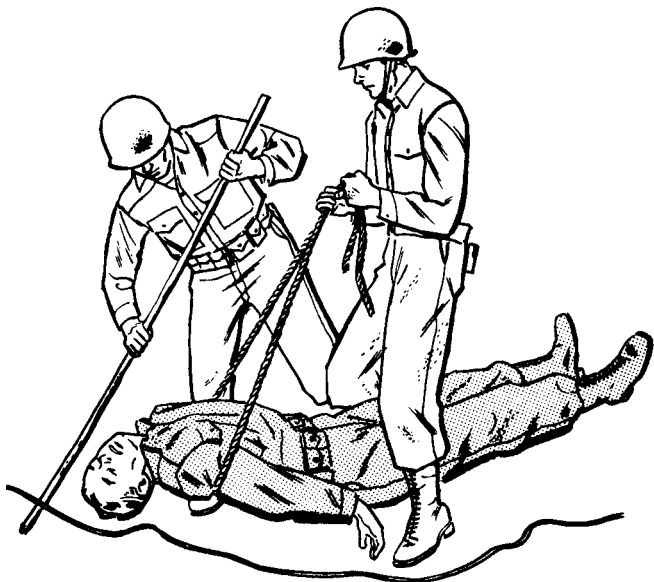

Figure 4-89. Rescuing an electric shock victim.

external bleeding. A compound fracture, sometimes referred to as an open fracture, is a broken bone that has pierced the skin.

a. *Signs and Symptoms of a Fracture.* The following are indications that a bone is broken ;

- (1) Tenderness over the injury with pain on movement.
- (2) Inability to move the injured part.
- (3) Unnatural shape (deformity).
- (4) Swelling and discoloration.

b. *Treatment.* If you think a person has a broken bone, handle him with great care. Rough or careless handling causes pain and increases the chances of shock. Furthermore, the broken ends of the bone are razor-sharp and can cut through muscle, blood vessels, nerves, and skin. Remember -do not move a casualty with a fracture unless it is necessary. If you do, be gentle and keep the fractured part from moving. If there is a wound with a fracture, apply a dressing as you would for any other wound. If there is bleeding, use the first aid methods for stopping bleeding.

c. *Splinting.* All fractures require splinting. Persons with fractures of long bones or of the bones of the pelvis, back, and neck, should be splinted "where they lie" before any movement or transportation is attempted. Proper splinting greatly relieves the pain of a fracture and often prevents or lessens shock. Fixing the fragments of a broken bone by use of splints prevents the jagged edges of the bone from tearing blood vessels and nerves. Proper splinting of a closed frac-



SIMPLE FRACTURE



COMPOUND FRACTURE

Figure 4-90. Fractures.

ture will prevent the bone from piercing the skin and causing the fracture to be an open one. Proper splinting of an open fracture will prevent further injury to the wound. First aid in the field may require that you improvise splints from whatever material you may have handy-tree limbs, poles, rifles, cardboard, rolled newspapers or magazines, etc. You should remember that splints should always be padded, especially where they come into contact with bony parts, such as the elbow, wrist, knee, and ankle joints. Leafy vegetation can be used to supplement pieces of clothing used for splint padding.

(1) *Splints for fractured bones of the leg, thigh, and hip.* To splint a fractured leg, roll sticks or other support into a folded blanket, or other padding material, to form a padded trough in which to rest the injured leg (fig. 4-91). Bind the splints firmly at several places above and below the break. Splints for a leg fracture should extend from a point above the knee to a little below the foot (fig. 4-91). In case of a fractured

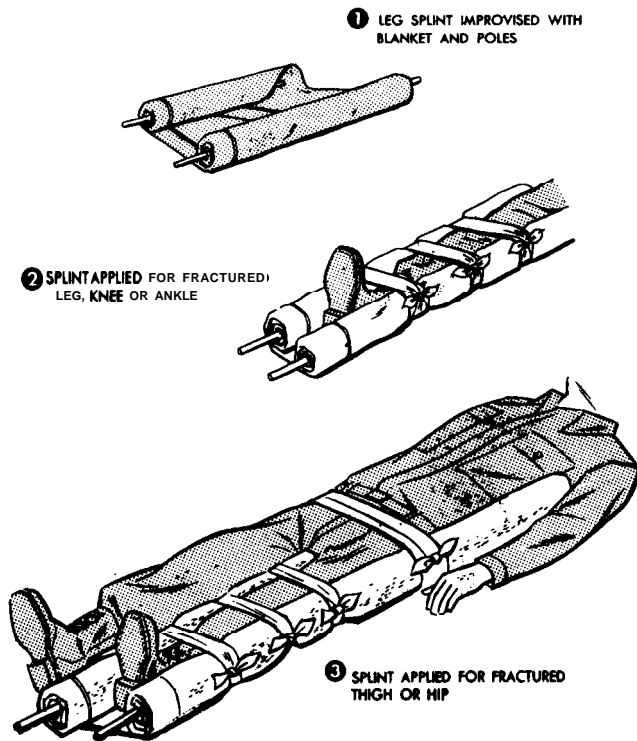

Figure 4-91. Improvised leg, thigh, hip splints.

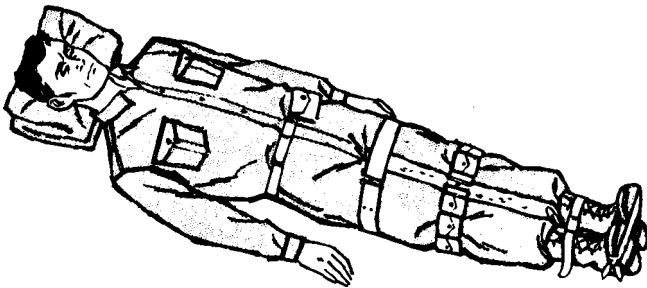

Figure 4-92. Expedient leg splint.

thigh or hip, poles and blankets may be used for splints as for the leg, except that the inside splint is extended from the crotch to a little below the foot. The outside splint is extended from the armpit to a little below the foot. The armpits and the crotch must be well padded. A quick way to splint a broken leg is to tie it to the casualty's uninjured leg (fig. 4-92). Padding is placed between the person's legs, then the legs are tied together at several points above and below the fracture. The casualty's feet with shoes on should be tied across the arches and toes.

(2) **Splints for fractured bones of the arm.** Keep a fractured bone of the arm from moving by supporting it with splints. This reduces pain and

prevents damage to the tissues. Temporary splints can be made from boards, branches, folded cardboard, magazines, newspapers, etc. A good general rule to remember in splinting any long bone (bones of the leg, thigh, forearm, or upper arm) is to have the splint long enough to extend from above the joint above the fracture to below the joint below the fracture. Splints should always be padded with some soft material to protect the limb from pressure and rubbing. Bind splints securely at several points above and below the fracture, but not tight enough to interfere with the flow of blood. It is well to apply two splints—one on either side of the arm. If an injured elbow is bent, do not try to straighten it; if it is straight, do not try to bend it. Figure 4-93 shows examples of splints correctly applied to the forearm, upper arm, and elbow to support the fractured bone and to prevent its moving. In figure 4-93, padding of splints has been omitted for clarity. A sling is the quickest way to support a fractured bone of the arm or shoulder, a sprained arm, or an arm with a painful injury. The arm should be bound snugly to the body to prevent movement. You can make a sling by using any material that will support all or a portion of the lower arm and hold it close to the body (fig. 4-94).

**d. Broken Back.** It is often impossible to determine whether a casualty has a broken back. Be suspicious of any back injury, especially if the back has been sharply struck or bent, or if the casualty has fallen. If a casualty has received such an injury and he lacks feeling in his legs or lacks the ability to move them, you can be reasonably sure that he has a severe back injury which should be treated as a fracture. You must remember that if there is a fracture, the sharp bone fragments can cut or damage the spinal cord and cause permanent paralysis (fig. 4-95).

(1) **Procedure for handling a spine-fracture casualty.**

(a) Place a low roll, such as a bath towel or clothing, under the middle of the back to support it.

(b) Lift the casualty, if he must be moved, onto a litter or board without bending his spine forward. It is best to have at least four men for this job (fig. 4-96).

(c) If the casualty is in a face-down position, he may be carried face down on a litter.

(d) Keep the casualty's body alignment straight and natural at all times and keep the air

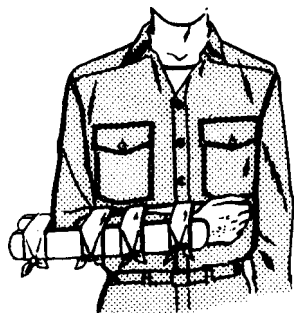

1 SPLINTS FOR A **BROKEN** WRIST OR FOREARM

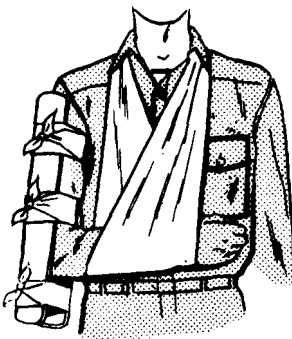

2 SPLINTS FOR A **BROKEN** UPPER ARM

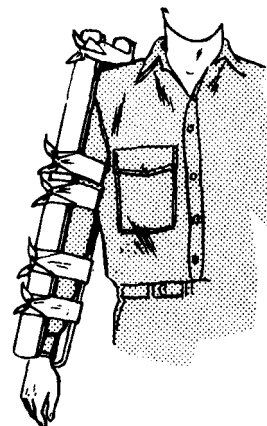

3 SINGLE STRAIGHT SPLINT FOR A FRACTURE NEAR THE ELBOW WHEN THE ELBOW CANNOT BE EASILY BENT

Figure 4-93. Splints for a broken arm.

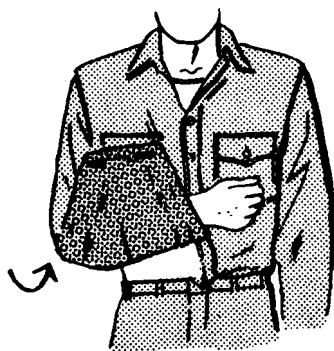

1 TURN **TAIL** OF JACKET OR **SHIRT** UP OVER INJURED ARM AND FASTEN IN PLACE WITH **PIN** OR TWIG.



2 **BINDING** THE ARM TO THE CHEST WITH A BELT OR CARTRIDGE BELT GIVES **ADDITIONAL** SUPPORT

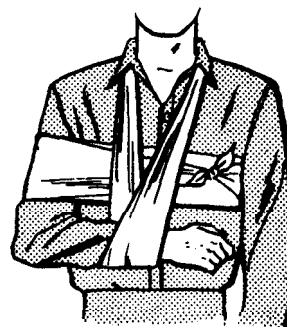

3 **SUPPORT** THE FOREARM IN A SLING MADE FROM A BELT OR STRIPS OF CLOTHING AND **BIND** THE ARM TO THE CHEST

Figure 4-94. Slings for an injured arm.



1 IN THIS POSITION, BONE FRAGMENTS CUT THE SPINAL CORD



2 IN THIS POSITION, BONE FRAGMENTS ARE IN PROPER PLACE AND WON'T CUT THE SPINAL CORD

Figure 4-95. Positioning a broken back.



Figure 4-96. Four-man carry.

passages free. If he is conscious, caution him not to move.

(2) **Cautions. Do not-**

(a) Move the casualty with a broken spine unless absolutely necessary.

(b) Raise his head even for a drink of water.

(c) Twist his neck or back.

(d) Carry him in a blanket face up (fig. 4-96).

**e. Broken Neck.** A broken neck is extremely dangerous. Bone fragments may cut the spinal

cord just as in the case of a broken back. **Keep the casualty's head straight and still with the neck slightly arched.** If he is conscious, caution him not to move. **Moving him. may cause his death.**

(1) A broken neck is protected as follows :

(a) Place a rolled bath towel, or a roll of clothing about the same bulk as a bath towel, under the neck for support and padding. The roll should be thick enough only to arch the neck slightly (fig. 4-97).

(b) Raise the shoulders in order to place the roll under the neck. Do not bend the neck or head forward. Do not twist or raise the head at all.

(c) Place the roll so that when the casualty is lying flat, the back of his head touches the ground.

(d) To keep the head motionless after the roll is in place, put a large padded rock or pack at each side of the head (fig. 4-97).

(2) If the man must be moved, get help. One person should support the man's head and keep it straight while others lift him. Transport him on a hard stretcher or board.

(3) Never turn over a casualty who has a broken neck.

**f. Fractured Ribs. Fractured ribs** cannot be splinted, but the pain can be relieved by restricting the movement of injured ribs. This is done by binding a tight swathe of muslin bandage around

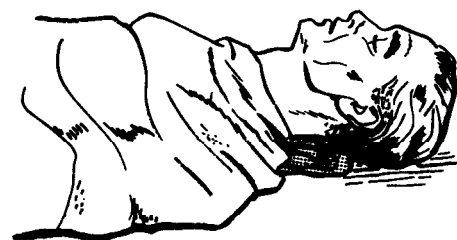
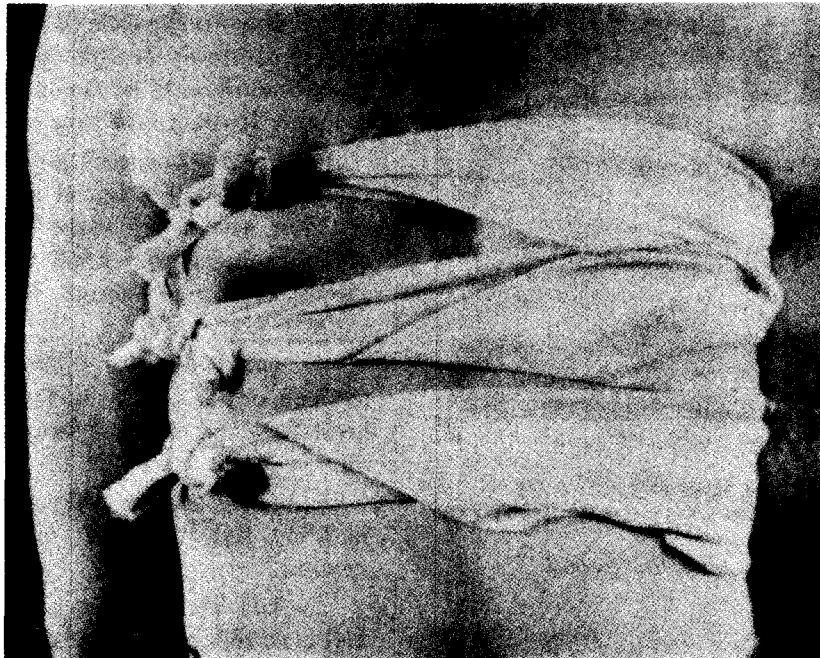
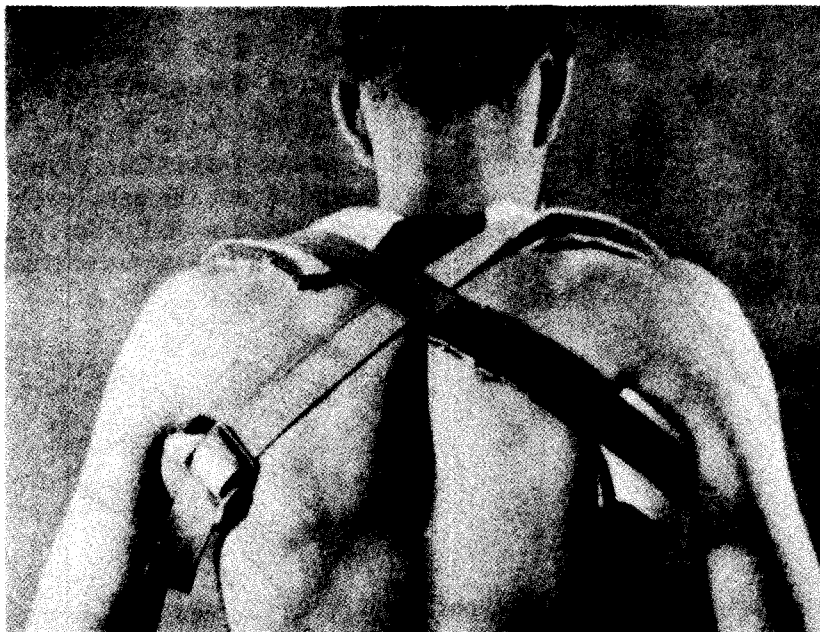

Figure 4-97. Protecting a broken neck.



*Figure 4-98. Immobilization of fractured ribs with cravats,*



*Figure 4-99. Method of immobilizing clavicle.*

the chest or by applying three triangular bandages, folded as cravats, **around** the chest (fig. 4-98). These are applied when the patient has forcefully exhaled the air from his lungs. Bandages are applied tightly enough to give support but not so tightly that the rib may pierce the lung.

g. *Fractures of the Clavicle.* When the clavicle (collarbone) is fractured, the break is easy to

detect. The shoulder on the injured side droops, bending the broken ends of bone upward and causing a noticeable deformity. The arm on the injured side cannot be raised and the patient usually supports it at the elbow with the opposite hand. The injured part is immobilized temporarily by one of the following methods :

- (1) Supporting the arm in a triangular band



Figure 4-100. *Bandaging a fractured jaw.*

age sling, holding the arm slightly higher than the elbow.

(2) Binding the arm to the chest wall with triangular bandages.

(3) Supporting the arm with a **figure-of-eight** improvised with two belts (fig. 4-99).

*h. Fractured Jaw.* Support the jaw with a cravat bandage (fig. 4-100), but do not obstruct the breathing. Place a wad of gauze between the teeth in back of the jaw to keep the jaws apart to maintain an air passage and to permit free drainage from the mouth.

#### 4-67. Burns

There are three kinds of burns: thermal, sunburn, and chemical burns. Burns are also classified according to the degree (depth) of the burn. A.

first degree burn reddens the skin. A second degree burn blisters the skin. A third degree burn is a deep burn where the underlying skin growth cells are destroyed.

*a. First Aid for Thermal Burns.* Victims of burns require treatment for shock, relief from pain, and prevention from contamination. Shock is the major hazard. It is usually serious when the burn involves 10 percent or more of the body surface, and sometimes less in especially deep third degree burns. The exclusion of air from the burn by the application of a thick dressing relieves pain and, if the dressing is sterile, prevents further contamination. At least four layers of dressing should be applied, then covered with clean, tightly woven material to exclude air. Hands must be thoroughly cleaned for this procedure. If the burn is extensive, involving the trunk or a large part of an extremity, wrap a clean sheet or large



towel around the part. Then cover the victim according to the weather and transport him to where he can obtain medical aid.

**b. Sunburn and Chemical Burns.** An intensive sunburn requires a sterile dressing, especially if blistered. Chemical burns must be washed with a large quantity of water, then dressed with sterile dressing according to the seriousness of the injury. Severe chemical burns and sunburns require medical attention in proportion to the seriousness of the burn.

#### 4-68. Heat Stroke

Occasionally hot weather causes heat stroke where the victim experiences a dry skin, rapid pulse, and a headache. This may develop into dizziness, nausea, and ultimately unconsciousness. The victim's temperature may rise to 106° F. (41° C.) and sometimes as high as 109° F. (41.7° C.). The afflicted person must be brought under cover, then unclothed and cooled by sponging the body with alcohol or lukewarm water. The patient requires immediate medical care.

### Section VIII. CONTROL, EXTINGUISHMENT, AND OVERHAUL

#### 4-69. Introduction

Hose, ladder, and pumper operations; alarm reception and response; sizeup, ventilation, salvage, rescue, and first aid have been discussed so far. It has been stated that an ideal situation would involve nearly all of these procedures being carried out almost instantly and simultaneously. Personnel rescue is the primary concern of any fire-protection organization. When rescue is accomplished, the secondary concern is fire control, extinguishment, and the related procedures essential to the preservation of property.

#### 4-70. Locating the Fire

Structural fires generally fall into two categories, the interior fire and the exterior fire. Both the interior and the exterior fires involve the same basic materials but under greatly variable conditions, quantities, and proportions.

**a. Structural Interior Fire.** The source of the structural interior fire lies inside the building. This fire may still be in an early stage of incipency after burning for several hours, and because of its confinement and lack of oxygen, or even lack of time, it has not yet burned through the exterior walls or roof of the building. This situation normally involves great quantities of smoke, ventilation problems, and backdraft possibilities along with the difficulty of finding the actual fire. Cases of suffocation involving both fire-protection personnel and occupants of the building must be anticipated. This type of fire normally does not involve exposure to other buildings unless the roof or walls suddenly collapse. Building collapse admits oxygen to the fire and expands it thus endangering nearby buildings by heat radiation. This condition is normally caused by delay in

gaining control of the fire after arrival, extensive enkindling before arrival, or widespread smoldering before sudden ventilation. The structural interior fire must be located, controlled, and extinguished from inside the building.

(1) Usually, before a fire can be controlled or extinguished, it must be located within the structure with some degree of certainty. A fire in the basement may appear to be in the attic or top floor, from which smoke is coming. Frequently, smoke from one building may entirely envelop an adjacent building, owing to wind conditions. The practice of standing in the middle of the street and directing hose streams through windows, regardless of where the fire may be inside the building, is now largely confined to the movie version of fire suppression.

(2) A hose line should not normally be opened inside a building until the fire is seen, unless a fog curtain is necessary to enable firemen to reach the seat of the fire. It is common for an incandescent lamp to appear as a fire in a smoky room. This deceptive condition also may be encountered when approaching an outside window or some other transparency which reflects sunlight or artificial light.

**b. Structural Exterior Fire.** A structural exterior fire may ignite within the building and burn through the roof or outside walls so that the fire in the building is ventilated by the burnt-out opening, and the flames are visible before arrival. The exterior fire may also be started first on the outside of the building by carelessly discarded cigarettes, flying embers falling on rooftops or on dry vegetation near the building, or by other causes. Exterior fires demand procedures to prevent the fire from spreading to nearby exposed buildings.

#### 4-71. Closing in on the Fire

After a fire is located, the next step is to confine it to its point of origin.

a. Its spread may be controlled by covering internal exposures with hose streams and shutting communicating doors and windows. External exposures will be covered by other firefighting units, if required. The greatest exposure is usually to the leeward of the fire. Although this may be the most difficult approach to make, owing to the wind's carrying the heat and smoke in the direction of the firefighters, it offers the greatest possibility for making a fire stop and preventing the fire from intensifying and spreading.

b. Fires cannot be **successfully** combated by paying undue attention to comfort. However, if it is obvious that the fire is not likely to spread beyond a certain point, such as an unpierced brick **firewall** or exterior wall, or that it is entirely within one room or building, needless physical punishment can be avoided by making the approach from the windward side.

c. The fire should be attacked from as many sides as possible. Good ladder work and proper ventilation are of invaluable assistance when locating, confining, and closing in on the fire. One precaution is worth repeating: where there is danger of back draft (superheated gases which have not ignited owing to lack of oxygen), be certain that the hose lines are in position and charged before "opening up". This condition is usually present in a tightly closed room or building. It is recognized by heavy smoke oozing out of cracks around doors or from beneath eaves.

d. Closing in consists merely of moving in on the fire as rapidly as conditions permit. Hose lines should not be advanced so rapidly, however, that the fire will be allowed to rekindle and gain headway in those areas where only initial extinguishment has taken place.

e. This is especially true when class B (flammable liquids) materials are involved and extinguishing agents such as CO<sub>2</sub> or dry chemical are being used. It is most important to remember that when these agents are used, they should be backed-up with a water fog line or possibly even a foam line. This precaution safeguards against a sudden **reignition** (flashback), which is so typical of class B materials, unless light water is used. Firefighters have been seriously burned because they failed to observe this precaution when combating a fire. In

one case, for example, fire had involved a paint room, and **laquer** thinner was blazing on the floor. Firefighters using carbon dioxide extinguishers to clear a path to the leaking supply tank had to make a dash for safety, in which two were burned quite badly, when the thinner suddenly reignited behind them.

f. Moreover, firefighters should be cautious against stepping into open shafts in the dark or advancing too far on weakened floor supports. Where caution may be necessary, the firefighter should "feel his way with his feet" or even crawl on his hands and knees. If large cracks appear in masonry walls, which may happen when a stream played upon them causes contraction on one side while leaving the other side expanded, collapse may be imminent, and preparation for withdrawing personnel and equipment must be made quickly.

g. When advancing against radiated heat, the helmet should be turned around so that the broad part shields the face. This part provides considerable protection although it will not provide safety in the actual presence of flame. Rotating men at the nozzle, with the men backing up the line from rear to front, will enable each man to rest or cool off when the exposure to heat causes discomfort. The nozzleman is normally the only person **subjected to any great degree of heat because, the men behind him get considerable protection from even a single person between them and the fire. If it becomes necessary to retreat from an advanced position rapidly, as, for example, when the water supply fails, causing hose lines to go limp, and the smoke is so dense that a means of escape is not readily visible, remember that following the hose line backward is certain to lead to the outside and safety.**

h. **The most suitable extinguishing agent for the type of fire encountered should be used in an amount that will most quickly put out the fire and a minimum of damage from its use.**

i. **Basic factors which must be considered in the extinguishment of a fire are the type of material involved, the quantity of the material, and the details of its arrangement. The ideal situation consists of opening a door of the building and extinguishing the fire from the outside, where the air is cool and plentiful and there is little danger of physical abuse. Usually it is not that easy. Often the firefighters must go inside and move with impeded speed, in increased temperature,**

with limited vision, and perhaps with an almost depleted supply of oxygen.

*j.* Standpipe systems within the building should be used whenever practical to save time and prevent damage. They are practical when the fire is too large to be held in check with a first aid extinguisher but has not spread so much as to require the volume of water supplied by a large line.

#### 4-72. Overhaul

The overhaul operation involves a complete and detailed check of the structure or structures involved and of all material therein. This check is to insure the complete absence of abnormal heat and the extinguishment of every spark, so there is definite assurance against re-ignition.

*a.* Perhaps the most embarrassing occurrence in the career of the fire chief and his crew is to receive an alarm directing the return of men and equipment to the scene of a fire which was recently "extinguished." A second fire is frequently more difficult to control than the original fire.

*b.* Before overhauling is started, the first step is to survey the building for structural damage to determine that collapse is not imminent. (**Incidentally**, water-soaked stock, such as cotton materials, increases the floor load tremendously.) When necessary, the gas and electricity should be shut off as a further precaution. However, the most important aspect of the work is to make certain that the fire is fully extinguished.

*c.* The building should be checked for concealed spaces where the fire may continue to burn unnoticed. These spaces are between floor joints, ceiling beams, false or hanging ceilings, walls and partitions, inside cornices, inside window door casings, light and air shafts, pipe or wire recesses, chutes, and dumbwaiter shafts. They may be checked by sliding a hand over the surfaces. If they feel warm or appear blackened or if there is any doubt of the situation, the suspected area must be opened up and investigated. The inspection holes should be square openings and near the studs in order to avoid unnecessary damage and to simplify the repair job. Then the adjacent areas should be checked thoroughly, including attics, basements, walls, and adjoining occupancies for possible spread.

*d.* To make sure the fire will not rekindle, glowing textiles, such as mattresses and clothing, should be submerged in water. Smoldering bales

of paper, rags, kapok, and similar material should be removed to the outside and broken open in order to extinguish the deep-seated fire in the center. Recent developments in the use of wetting agents or surface-active agents added to water in about a **2-percent** concentration indicate the future possibility of more quickly and effectively extinguishing fires in those materials not penetrable by plain water. Such agents would make it unnecessary to tear the objects apart and submerge each fragment in water. Surface fires involving lumber are extinguished quickly, but because of the normal resistance of charcoal to water, it is possible that heat and sparks may remain active for some time beneath the surface. Under such conditions, a water solution containing a wetting agent may be effectively used to save time, damage, and energy.

*e.* Oil-soaked metal filings, lampblack, or other **finely** divided substances should be examined with care because they are possible sources of **re-ignition**. Cylinders, **carboys**, and other vessels containing gases and chemicals should be segregated to avoid their mingling and a resultant explosion.

*f.* Burned materials should be handled carefully. Clothing or other objects which may contain articles of value should not be thrown out of **windows**. If it is necessary to dump debris from upper floors, a firefighter should be posted below to warn others of the danger. Particular caution should be taken when handling poisonous or corrosive substances. Rubbish carriers, consisting of old salvage covers cut into 5 by **5-foot** (162 by **152-centimeter**) sections with handles on the corners, provide a convenient means of removing fallen plaster and debris. Burned materials should be segregated from the unburned objects, and undamaged goods placed where they will not be subject to damage during overhaul.

*g.* Precautions should be taken to guard against subsequent injuries. Holes which may have been burned or cut in the floor should be covered or blocked off and approaches to damaged stairways or elevator shafts should be obstructed. Walls or chimneys which have been weakened seriously and which endanger pedestrians should be pulled down.

*h.* If it becomes necessary to respond to another alarm or return to quarters, and there is a possibility that the fire might rekindle, a firefighter should be left on watch at the scene with a line charged for instant use,

## Section IX. INVESTIGATION AND RETURN TO SERVICE

### 4-73. Introduction

The investigation of a fire, which is the last thing concluded before return to quarters, primarily **includes** the preservation of evidence, especially of arson. The preservation of evidence in many cases overlaps into the overhaul operations and even into control and extinguishment.

### 4-74. Initial Investigation

If the circumstances upon arrival give rise to a suspicion of arson, fire investigators should be called.

a. Photographs should be taken before any **disturbance** of the environment beyond that which was caused by extinguishment. When **circumstances** point to arson, suspicious **devices—such** as gasoline cans, cotton trails, film trails, candles, oil-soaked rags, cleaning fluid containers, matches, and cigarettes—should be labeled. The label's should indicate the finder and where and when the suspicious items were found. Notes should be taken immediately on the following: recollections as to persons present on arrival; existence of two or more separate fires simultaneously ; color and aroma of smoke ; color of flame and from where it was issuing. A record should also be made as to whether doors were locked from the inside or outside; condition of contents and whether disarranged or removed ; nature of the burning material; direction of wind; humidity, temperature, and general weather conditions ; direction of spread; obstruction extent of windows in the room where the fire was believed to have been started; whether a passerby may have seen the **arsonist** making arrangements inside ; and any other relevant facts.

b. Notes and sketches made at the scene while the facts are fresh may be used to reconstruct minute details which may be come significant as the entire picture takes form. The facts may be requested during a board of inquiry or **investigation** proceedings, or even in court, if an arsonist is caught and later brought to trial.

c. If the investigating officers have not arrived before the firefighters must return to the station, military policy should be posted to preserve the evidence. They should be instructed to disclose no opinion about the fire, its origin, or any facts which may have been **discovered** as to its cause, except to proper authorities.

d. If the fire has involved a building in which are stored classified documents or equipment such as reels of film, models, drawings, files, or similar items, the officer in charge of the fire should **request** that an adequate guard be posted over the area where the items have been gathered until they can be removed to a more secure location. Since **firefighters** are not authorized to **examine classified** materials, the men should be cautioned to be extremely conscientious and attentive when **handling** such items or when sorting them from the debris and to set them aside in the designated location promptly. This point is stressed because there have been examples of carelessness and of unnecessary loss or destruction. Instances are also known in which firefighters have taken time out after the fire was extinguished to unroll reels of confidential film to see if they contained anything interesting. These firefighters were of course **censured** and even investigated according to the **degree** of importance of the material involved.

e. Before returning to the station, the chief in charge should obtain all the facts necessary to write up the required fire report. This report includes type of alarm ; location of fire ; building number; description, origin, cause, and confinement of the fire ; damage ; agents used ; time required ; number of personnel ; mileage traveled.; weather ; remarks ; and other necessary data.

### 4-75. Determining the Origin of the Fire

When the fire has been serious, that is, when there has been loss of life or extensive property damage, assistance in investigation may be obtained from the fire marshal or other authorized representatives of higher headquarters so that an impartial viewpoint may be expressed at any later board of inquiry or board of investigation proceedings.

a. In such cases, the investigating authority will attempt to collect much more detailed information than would be required ordinarily. This investigation might include such matters as reasons for possible delay in alarm, for extensive spread of fire, for heavy lose, and for the inability of **occupants** to escape. It might also consider the **fire-fighting** methods employed, the adequacy of the watter supply, and whether recommendation had been previously made to correct deficiencies which may have caused the fire, delayed the alarm, or impeded extinguishing operations. For the **aver-**

age response, however, the regular fire report form is enough to record the necessary information. The questions on this form that may be difficult to answer accurately are origin of fire, cause, and estimate of damage.

*b.* When there are no eyewitnesses, the exactness with which the point of origin of a fire may be determined will depend, in most cases, on the extent of the fire. When several buildings have been destroyed, it may be possible only to designate one of them as the place of origin. The same may be true when a number of rooms have been gutted by fire. On the other hand, if the fire has been confined largely to one room, it may be relatively easy to determine the point of origin; this may be indicated by defective wiring, a wastebasket, a stove, or any one of the many other sources.

*c.* In a great many cases however, the **exact** point of origin is often difficult to determine. The tendency is to pronounce the first plausible spot as the probable location at which the fire **started**.

*d.* For example, after a fire which involved a large one-story frame woodworking shop, the following facts were disclosed by the debris. Paint cans had been burned out with no trace of rag ashes. Nearby, behind a door, was a partially burned pile of shavings, sweepings, and remains of a broom. Nonmetallic sheath wiring was badly burned and holes were burned through the metal conduit, but the fuse box and fuses were intact. There was heavy charring around air vents through the roof. One outside wall was burned completely through. Outside this opening and against the building were the partially burned remains of a pile of heavy lumber which had been involved in fire, and near the edge of the pile were the burned remains of what might have been a broom handle.

*e.* Where did the fire start? Judging from this information, it would be impossible to say. While deep charring of the wood beams around the ceiling vents might indicate that the heat was very intense at that point, it is only **what** should be expected, since these vents provided a natural flue to draw off the heat and fire. The presence of paint cans does not necessarily indicate the location of the origin. Even if these cans were empty at the outbreak of the fire, the residue would have burned out during the course of the fire. The absence of rag ash does not rule out the possibility of spontaneous ignition, for linseed oil may have been present on newspaper or other materials, or

all of the ashes may have been washed away by hose streams.

*f.* In regard to electrical difficulties, the intense heat of the fire could have burned off the insulation of the nonmetallic sheath cable along the ceiling. The arcing of wires, which had become bare as a result of the heat, would account for the burned hole in the metal **conduit**. The absence of bridged fuses or overcapacity fuses would not rule out the possibility of electrical difficulties, for fire can start from frayed wires or overheated motors without blowing fuses. In addition, the electric glue pots, along with other heating devices, were checked for possible overheating, but these had apparently been shut off before the fire started.

*g.* Investigation disclosed that no one had been in the building since noon the day before. Thus, the possibility of a carelessly disposed of cigarette being thrown into the rubbish pile or elsewhere was rejected. Close inspection of the burned surfaces of the outer wall disclosed that the fire had started outside the building under the woodpile. The remain's of the wooden handle found in the pile showed it to be of a type similar to those on mops found on a nearby outside rack, all bearing evidence of having been used for mopping a vegetable oil. It was apparent that an oil soaked mop had been left on the ground the previous day, with the wood piled on top of it against the frame building. A statement by workmen eventually verified this conclusion. There had been enough time for spontaneous heating and the resultant outbreak by the next day. Therefore, it **was** not **difficult** to guess the cause of the fire, after the possible sources were found, considered, and eliminated with proper **reasoning** and due consideration.

*h.* Thus, it can be seen that determining the point of origin may be very helpful in determining the cause, if not directly, then indirectly, by eliminating other possible causes. Although certain indications point to the greatest concentration of heat, which may be useful in **locating** the point of **origin**, these indications are not always infallible. The prevailing drafts during a fire have a great deal to do with the way the fire spreads and the manner in which heat is concentrated. In addition, some materials are more highly resistant than others and show less evidence of heat conditions than lighter and more flammable substances. An example of differing resistance is glass and iron. Glass that has become molten and fused indicates that the temperature had reached the **vicin-**

ity of 1,700°F. (927°C.); ordinarily unprotected iron supports will warp at slightly over half that temperature.

*i.* Moreover, it must be kept in mind that the cause of the fire and the point of outbreak may not always be in the same location. This may occur for example when gasoline vapors are carried by drafts to an open flame or to the arc of a knife switch a considerable distance away. It could also happen where combustible materials at one end of a duct are ignited as a result of an overheated furnace at the other end.

*j.* The recurrence of several fires in the same location or the presence of two or more simultaneous fires in different areas of the same building should be viewed with suspicion. There is a possibility of deliberate planning, and a more careful investigation is warranted.

#### **4-76.** Determining the Cause of the Fire

After having determined as far as practicable the point of the fire's *origin*, the next *step* is to determine its cause.

*a.* It is well, in ascertaining its cause, to consider first the most common causes of fire, such as carelessly discarded cigarettes, overheated or defective stoves or flues, faulty electrical appliances, and slag or sparks from welding and cutting operations. If these are eliminated beyond a reasonable doubt as a possible source of the fire, a thorough interrogation of all persons potentially connected with the fire may *throw* additional light on the subject. Such personnel would include those who ordinarily occupy the building, those who were present at the time of or immediately before the discovery of the fire, and those who last left the building at quitting time or who later went through or near it. Such extensive *investigations* are only required for large fires or those involving a loss of life. They will usually be conducted by specially appointed *officers* or boards, with the assistance of the fire marshal and appointed *aides*.

*b.* Although it is true that approximately 70 percent of the total fire damage results from only about 10 percent of all fires, it does not follow that smaller fires should not receive careful study. Small fires can teach about fire protection measures. If any gain is to be made in preventing similar occurrences, it is of the utmost importance to determine the source of the fire and the particular manner in which it started. Hence, when fill-

ing out a fire report, it is not enough merely to list "rubbish," "grass," or "flammable liquids" as the cause of fire. These items are simply examples of combustible *materials* which are not uncommon in the vicinity of many buildings. The *cause*, in a strict sense, is the agency which brings the combustible materials up to their ignition points. For example, the "point of origin" might be "rubbish can in northeast corner of hanger No. 301," "dry grass on west side of building No. 731," or "bucket of gasoline near the center of the floor in garage building No. 43." The *cause* of the above fires may have been a cigarette carelessly discarded into the rubbish, sparks from an unprotected incinerator landing in the grass, or the spark from a broken light bulb in an unguarded extension cord socket in the vicinity of the gasoline vapors from the bucket. This type of fire analysis makes possible a decision about whether new fires can best be prevented by regulating the sources of ignition, the handling of combustibles, or both. If it is impractical to eliminate the former, stricter controls can be placed upon the handling and disposal of highly combustible materials. In the foregoing illustrations, it so happens that both the causes and the points of origin are the proper subjects of regulation or prohibition.

#### 4-77. Estimate of loss

Accurate appraisals of monetary losses resulting from fires are often difficult to make.

*a.* When the loss is negligible, it will be found advisable to obtain the assistance of the post engineer, who is qualified to estimate the cost of any necessary repairs. Note that the typical fire report calls not only for an estimate of loss in dollars but also for a brief description of the extent of physical damage. The fire chief should make such a description, but the decision regarding replacement or bracing of weakened construction such as joists and walls should be made by the post engineer. Photographs are of great help in establishing the extent of structural damage and in preserving evidence.

*b.* Partial losses of Army structures are estimated by the installation personnel charged with construction responsibility. Total structural loss of an Army building is the value of the structure as reported on the most recent inventory of the real property report (AR 405-45) prior to the fire (AR 385-12).

been built when construction costs were either higher or lower than at the time of estimate. It is best to make an estimate on the basis of the present cost of restoration to the original conditions. Loss estimates should **be** made by personnel charged with construction responsibility. Total structural loss is the value of the structure when built plus improvements.

**c.** Before an estimate can be made of the loss to contents, an inventory of everything remaining after the fire is extinguished must be taken and **compared** with a previous inventory of the contents. Since the loss includes damage from smoke, heat, and water, as well as that sustained by actual contact with the flames, it can be accurately appraised only after the salvage value, if any, has been determined. This is a task for the supplying **service**.

**d.** Vehicle and aircraft losses will be **determined** by replacement in kind for partial losses and recorded inventory value less salvage for total losses.

**e.** When preparing his preliminary report, the fire chief is not expected to go into great detail in his loss estimate. He should be guided by **the** figures given him by proper authorities, if these figures are available. These figures may be challenged only if a considerable discrepancy is noted. For example the itemized loss sheet may indicate that much more property was destroyed in the building than it was known to have contained, or it may indicate the destruction of important objects which fire personnel know the building did not contain (**by** reason of their having made an inspection just before the fire and an investigation of the debris afterward). These facts should be called to the attention of the proper authorities so that the mistake can be corrected or other appropriate action taken.

#### 4-78. Final Action at Scene of the Fire

In the case of large fires, it is well that the ranking fire protection officer in charge should obtain all the information possible before leaving the scene in order to prepare a coherent story of the fire and the way it was extinguished.

**a.** Considerable time may be involved in taking the names of witnesses, jotting down significant statements, directing the taking of photographs, and drawing sketches of the building, location of apparatus, hose lines, and other pertinent facts. Those companies not needed for salvage and over-

haul work should be directed to "pick up" and return to the station.

**b.** Before leaving the scene of the fire, fire protection supervisors should make a **double** check to assure that no tools or equipment are missing from the fire apparatus. When equipment, such as salvage covers placed over holes in the roof, has been temporarily lent to the occupant, a receipt should **be** obtained and instructions given for its return.

**c.** Even though the fire station is relatively close by, some precautions should be taken in case another fire occurs before the apparatus gets completely back into service. When almost the entire hose supply has been use& it is frequently advisable to reload the hose in the bed of the firetruck so as to be in readiness for instant use in case another fire occurs before the hose can be changed. All wet or dirty hose must be replaced. Where only a few sections of hose have been used, they may be rolled up and stacked on the rear running board, since there would most probably still be enough hose in the bed to **combat** another fire successfully.

**d.** When a crew is returning from a fire, the necessity for getting back into service quickly does not constitute an emergency. Therefore, sirens should not be used and all traffic rules should be observed.

#### 4-79. Return to Quarters

**ct.** Upon return to quarters, the crew chief in charge should report to alarm headquarters, either that his company is back in service, or that it will be out of service temporarily while the hose is being changed. If the latter is the case, he should again notify headquarters when the company is back in service.

**b.** While the fire chief or crew chief is completing the required fire reports and making entries of the run in the daily log or journal, the members of the company should make an immediate check of the fire apparatus. Tires should be washed to facilitate an inspection for cuts, nails, and other damage. Fuel, oil, and water in the radiator and booster tank should be replenished if required. All equipment and appliances should be checked for presence and condition.

**c.** After clean dry hose is replaced in the apparatus bed, wet or dirty hose should be thoroughly washed and placed on the rack to dry. Hose should

be rolled as soon as it is dry in order to avoid deterioration from the heat of the sun.

*d.* Wet salvage covers should be washed, inspected for cuts or **tears**, and hung to dry. Ladders should be inspected for damage, and all tools and **appliances** which have become dirty or wet should be cleaned and dried. Metal surfaces which might rust should be lightly wiped with oil. The entire apparatus should be washed, if necessary, to remove caked mud, dirt, and carbon.

*e.* When all necessary work which follows a fire has been carried out, it is advisable to congregate all the men in the study room and review the method of attack from start to finish. Each company crew chief can explain the operation in which his crew was engaged, illustrating the placement of men and equipment on a blackboard. The purpose of such a verbal postmortem is not to criticize or embarrass anyone but to take full advantage of any lessons learned while fighting the fire, and to determine whether operations might be **improved** at any future fire of a similar nature.

*f.* If obvious mistakes were made at the fire, the persons in error should readily admit making

them. If the chief in charge is assured that a repetition of the same error will not occur, no particular issue need be made of it, especially if the error is a minor one. Serious mistakes, however, should not be passed over lightly merely because the department as a whole was praised. Most of the time, the general public believes that the fire department has done an excellent job, and perhaps that is usually true, but firefighters normally are aware of their own mistakes even when the uninitiated layman is not.

*g.* When a private reprimand is necessary to cover individual cases, it should be carried out promptly after return from the fire and before the general discussion is held. When improvement is a matter of general performance of duty, the postmortem session should be followed by drills and more drills until every man is functioning as an efficient **part** of the team. On the other hand, if **praise** is due a man or a company for a good job or an exceptional piece of work at the fire, appropriate words of recommendation should be given during the discussion in the presence of the entire group.



## CHAPTER 5

## AIRCRAFT FIREFIGHTING AND RESCUE

## Section I. INTRODUCTION

**5-1.** Purpose

This chapter provides Army firefighters with the correct procedures for rescuing personnel from burning aircraft and for fighting aircraft fires. Preservation of life and prevention of injury should be the first objective of all firefighters; the saving of aircraft is secondary.

## 5-2. scope

Various phases of aircraft firefighting and rescue are covered herein. Section I includes general information on the characteristics of fire as they pertain to aircraft and aircraft materials. Section II familiarizes firefighters with the specific components of aircraft and the fire hazards associated with them. Section III describes emergency procedures, and gives illustrations of the general arrangement and the emergency procedures for typical Army aircraft.

**5-3.** Flammable Materials in Aircraft

a. Flammable materials and fire-accelerating materials carried in each aircraft are of major concern to the firefighter. The materials may include a combination of the following :

- (1) Gasoline, turbine engine lubricating oil, and jet fuel.
- (2) Oxygen.
- (3) Oils.
- (4) Hydraulic fluid.
- (5) Anti-icing fluid.
- (6) Grease.
- (7) Pyrotechnics, ammunition, and other ordnance.

b. Of the above materials, gasoline and jet fuel are the greatest problem in firefighting. The crash firefighter must remember that danger of fire or explosion is always present in the aircraft fuel system.

**5-4.** Fire Hazards of Aviation Gasoline, Turbine Engine Lubricating Oil, and Jet Fuel

A knowledge of the characteristics of gasoline, turbine engine lubricating oil, and jet fuel is essential to the aircraft firefighter. See paragraph 4-3b for extinguishing class B fires.

a. *Gasoline and Turbine Engine Lubricating Oil.*

(1) *Aviation gasoline versus automotive gasoline.* Aviation grades of high-octane gasoline, with octane ratings of about 115 to 145, are not greater fire hazards than automotive grades with a rating of approximately 90. Actually, automotive grades have a slightly higher volatility. However, for practical considerations, gasoline of any octane rating within the automotive or aviation range (approximately 70 to 145) presents identical fire extinguishing problems.

(2) *Turbine engine lubricating oil and aviation gasoline grades and uses.*

(a) Whole, unheated turbine engine lubricating oil, Military Specification ML-L-7808, is relatively nontoxic and does not present a serious health problem. Some dermatitis can be expected in unprotected personnel continuously exposed to whole unheated oil. However, the decomposition products resulting from temperatures above 500° F. (260° C.) are toxic. Adequate ventilation should be maintained where these oils are heated above the critical temperature.

(b) Aviation gasoline consists of hydrocarbons except for the addition of chemical agents, such as tetraethyl lead, inhibitors, and dye. The various grades are dyed distinguishing colors of red, blue, green, and purple for identification purposes. Aviation gasoline is provided in four grades and colors, in accordance with Military Specification MIL-F-5572, as follows :

1. Grade 80/87, for use in light aircraft and helicopter engines, red if it contains tetraethyl lead, otherwise dye free.

2 Grade **91/96**, for use in light aircraft and helicopter engines, blue.

3 Grade **100/130**, for use in high output aircraft engines, green.

4 Grade **115/145**, purple in color, is the **standard** grade of aviation gasoline used in all Army aircraft gasoline engines (app. II).

**b. Jet Fuel.** Jet fuel is designated JP-4 (**Military Specification MIL-F-5524**) and is used in the gas turbine series engines installed in some Army aircraft. This type of fuel must be handled with as much caution as gasoline. Jet fuel mist in air ignites readily regardless of the theoretical advantages of a kerosene grade fuel.

## Section II. AIRCRAFT FIRE HAZARDS

### 5-5. What Firefighters and Operation Personnel Should Know About Aircraft

**a.** Firefighters and operation personnel must be familiar with the fire hazards of every aircraft that uses the nearby airfields. After an aircraft is on fire, it is too late to make a study of it to **determine** the best methods of lifesaving and **fire-fighting**. An aircraft fire requires immediate, intelligent, and carefully planned action. Every **situation** is different, but often the rescue squad has only a minute to rescue occupants from a burning aircraft.

**b.** A knowledge of the location, function, and operation of all parts of an aircraft is necessary, whether they appear to be fire hazards or not. Nearly any part of an aircraft may become important to firefighting, often under unanticipated circumstances. For example, a landing gear strut would not ordinarily be considered worthy of study from a firefighting point of view, but when it is known that on a certain type of aircraft the strut has been driven upward and has ruptured a fuel tank, it is evident that a knowledge of its **position** and action is important. A crucial decision on firefighting or rescue operations must often be made within seconds.

**c.** Features of aircraft which are directly **connected** with fire hazards and rescue are outlined in generalized form in the following paragraphs. These may be applied to the study and investigation of any specific type or individual aircraft. Such studies must be supplemented by personal inspection of the aircraft, contact with flight and maintenance personnel, and review of current **aviation** magazines and manufacturer's data. The best way to learn about aircraft is by inspecting and asking questions about them. Few aircraft, even of the same type, are identical in every respect. Some aircraft of the same type are altered for performance of different tasks. Others are assembled in different ways, or changed for special reasons after being in service.

### 5-6. Aircraft Design

**a.** Modern **Army** utility aircraft are of all-metal construction. Figure 5-1 illustrates the general arrangement of transport aircraft.

**b.** Helicopters differ from fixed wing aircraft in that lift comes from rotor blades mechanically rotated about an approximately vertical axis. Figure 5-2 illustrates the principal structural units of a helicopter.

**c. Helicopters** may be broken down into two main types: the single rotor type and the tandem rotor type. The single rotor type uses a small **anti-torque** tail rotor to overcome the effects of torque, while the tandem rotor type rotates the blades in opposite directions, thus reducing torque to an acceptable limit. The flight controls of a helicopter have primarily the same function as those of fixed-wing aircraft. The only additional control is the collective pitch stick, to the left of the pilot. A motorcycle-type throttle is attached to the end of the pitch stick.

### 5-7. Powerplants and Components

The engines are divided into two groups, the reciprocating engine and the gas turbine engine.

#### **a. Reciprocating Engines.**

(1) The reciprocating engines are air-cooled and constructed on a radial or opposed design. Radial types are used in larger engines and present the greater fire hazards. On a radial type engine, the cylinders are installed in one or more separate rows around the crankshaft. The crankshaft of a helicopter extends into the clutch or transmission assembly and forward to the propeller installation, and far enough to the rear to drive auxiliary equipment such as generators, oil pumps and hydraulic pumps. A radial engine and accessory section are shown in figure 5-3. Figure 5-4 shows an opposed engine and accessory section.

(2) The fire hazard in the cylinder section of the engine is very small unless the cylinders **frac-**

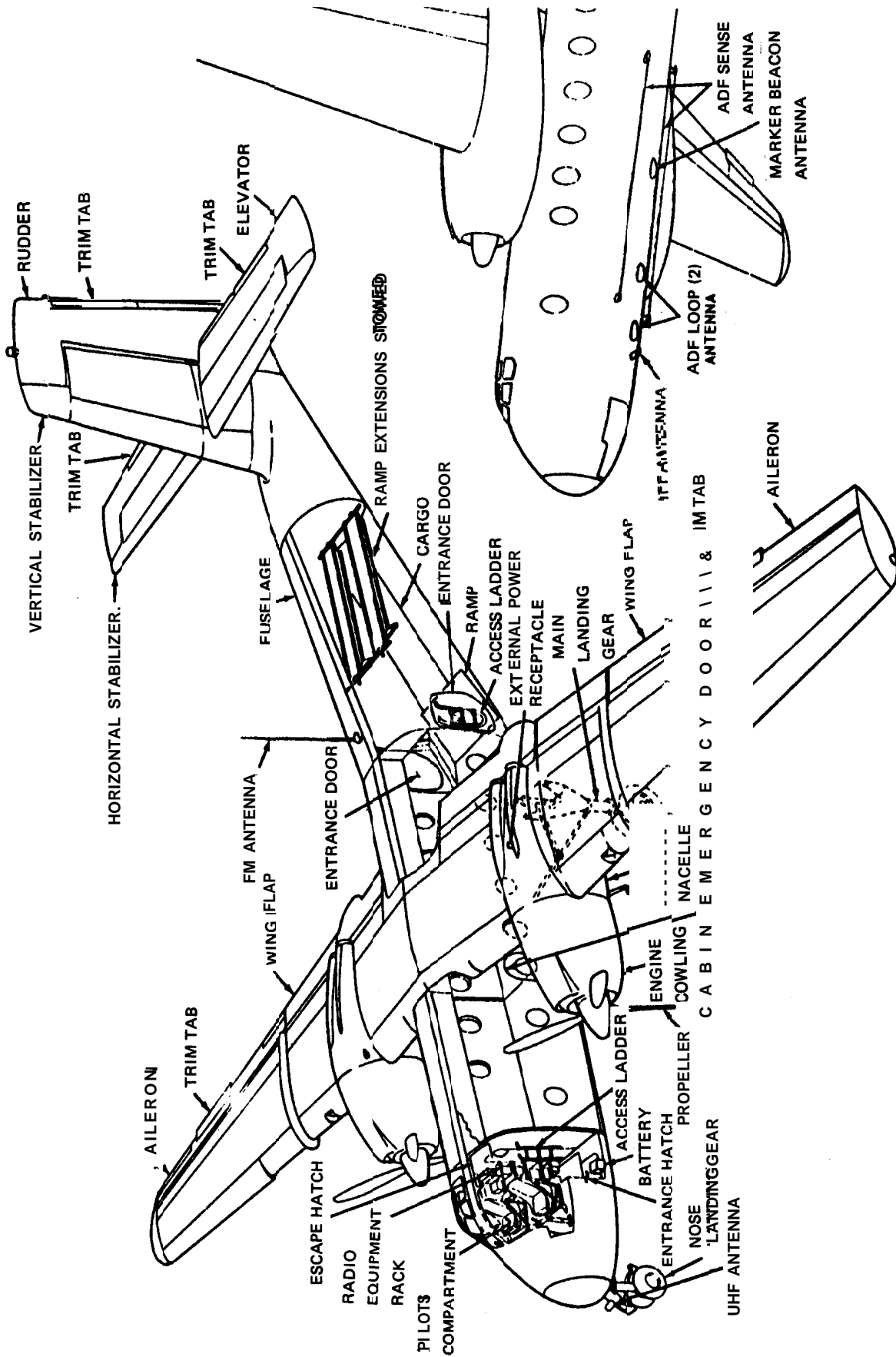

Figure 5-1. General arrangement of transport aircraft.

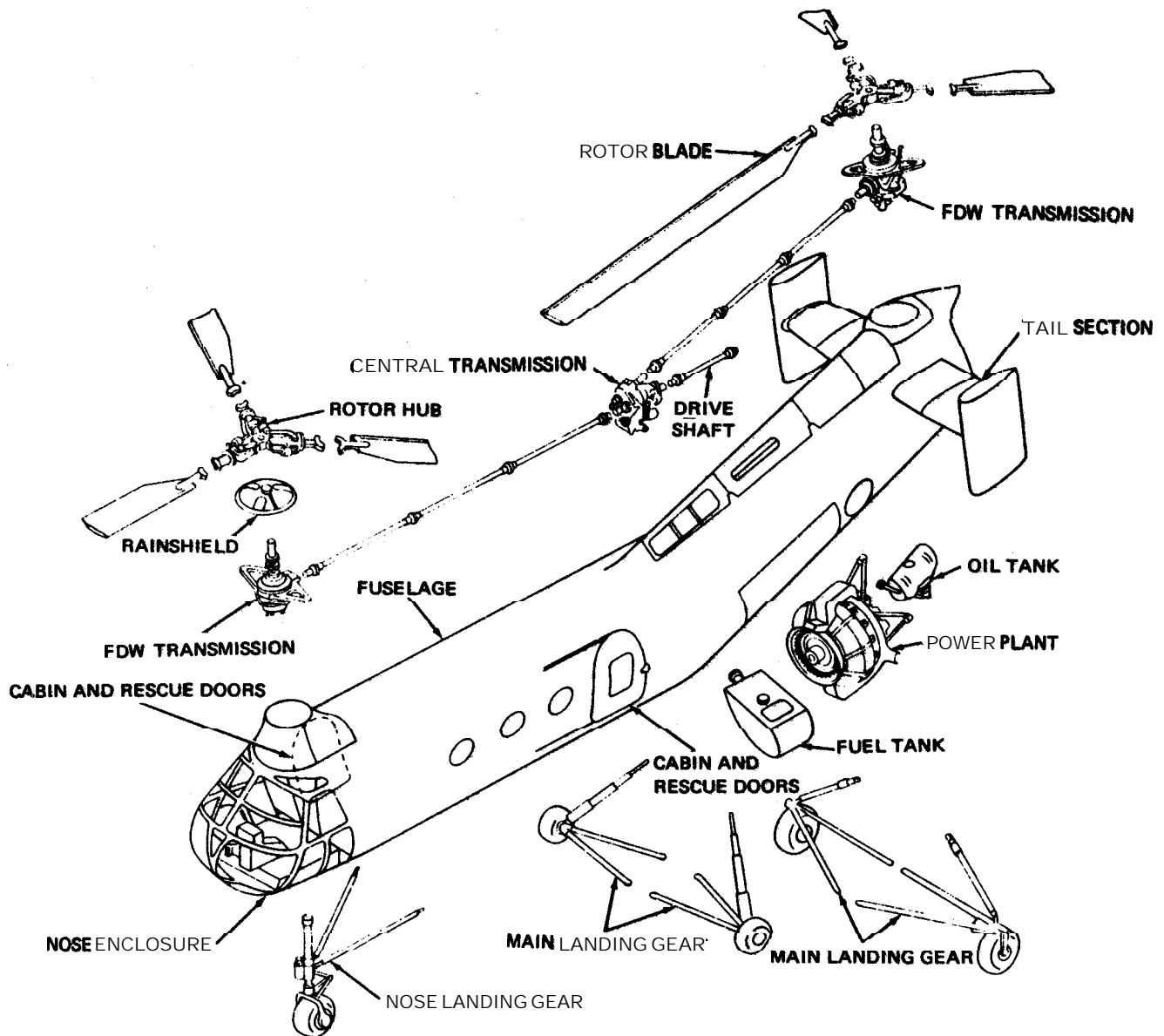

Figure 5-2. Principal structural units of a helicopter.

ture. The greatest fire hazard in the cylinder section are the electrical wiring, oil lines, and a small amount of tubing. An engine cylinder section seldom presents a fire problem.

(3) The accessory section is located immediately to the rear of the cylinder. The accessory section contains the carburetor, internal supercharger, main fuel lines, fuel pump, oil lines, oil pump, generator, magnetos, electrical connections, and other engine equipment. In some aircraft, the accessory section contains the oil tanks and storage batteries. The most serious engine fires occur in the accessory section.

(4) The accessory section is filled with equipment containing moving parts (figs. 5-3 and

5-4). Broken fuel and oil lines generally occur in the accessory section and are the source of fires both in the air and on the ground, either under normal conditions or in the event of a crash.

(5) Access to the accessory section is gained by removing the engine cowling. The cowling is fastened with dzus and other special rapid fasteners and can be quickly removed. The fasteners can be opened with a screwdriver which is part of the crash rescue tool kit (fig. 5-5) or a coin, since the exposed top is slotted for turning. Many instances occur where the intensity of the fire will prevent the removal of the cowling. It is then necessary to gain access to the accessory section by quick use of forcible entry equipment. The cowling is gener-

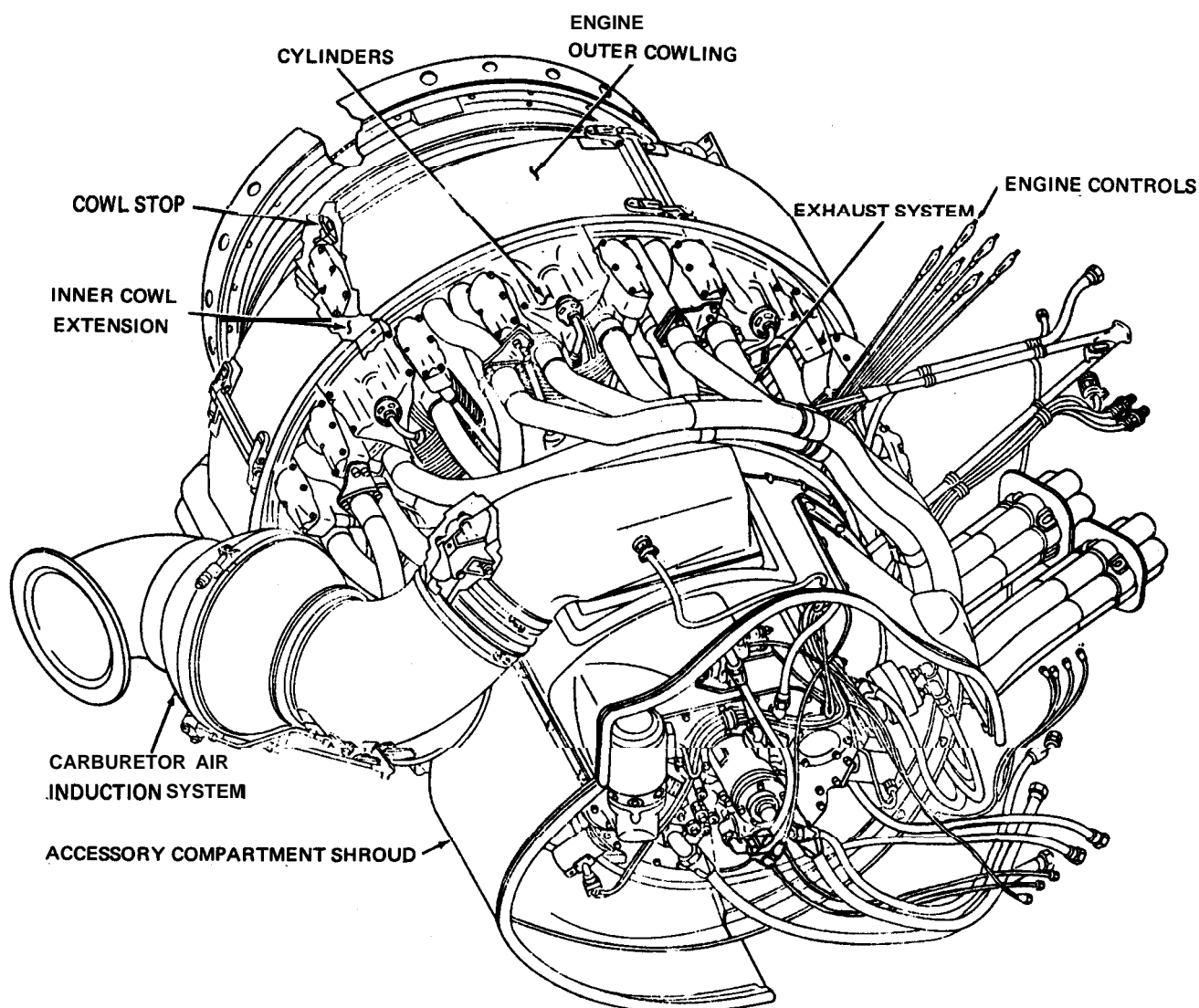

Figure 5-3. Radial engine and accessory section.

ally constructed of metal a little thicker than the aircraft skin, but can quickly be entered with crash kit tools. Effectiveness of the extinguishing agent within the confined space may be increased by keeping the cowling in place and by using bayonet nozzles or applicator.

#### NOTE

If it is a severe engine fire, check accessory section first.

(6) There may be a forward firewall or shroud between the forward section of the engine containing the cylinders and the accessory section. On most aircraft, a main firewall is located between the accessory section of the engine and the adjoining portions of the aircraft. In single-engine aircraft, the main firewall is between the

accessory section and the pilot's compartment. In multiengine aircraft, the main firewall is between the engine and the rear of the nacelle with its adjoining wing structure.

(7) Aircraft firewalls consist of a metal plate thicker than the aircraft skin. The firewalls are not thick enough to prevent the passage of heat for a long time or the actual transmission of fire from one section of the engine to another section or to the rear structures. Firewalls are pierced with necessary openings for cables, linkage, tubing, etc (fig. 5-4). In some instances, there is clear space between the device passing through the firewall and the opening. The objective of the firewall is to localize, for a brief time, a fire in the engine cylinders or accessory sections.

(8) It is important that firefighters know the

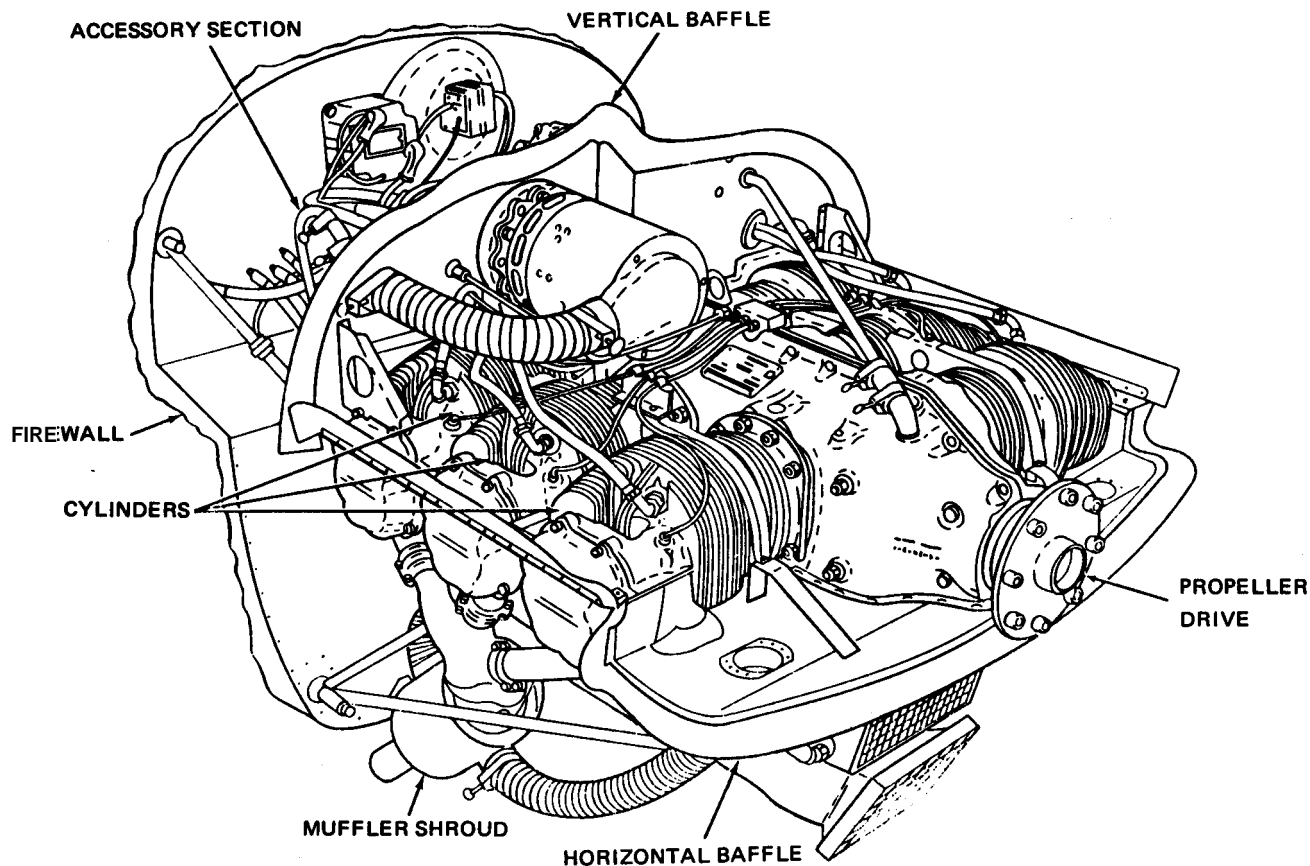

Figure 5-4. Opposed engine and accessory section.

location of firewalls and accessory section components. With the engine cowling removed, each type of engine should be studied from a **firefighting** point of view.

(9) On radial engines having only a single row of cylinders, baffle plates or shields are placed **between** the cylinders and the cowling. The shields are close-fitting and regulate the flow of air to the rear of the cylinders. The shields should not be confused with a **firewall** as they will do very little to localize a fire. Their purpose is to reduce the volume of air which can pass over the rear of the cylinder cooling fins. There is some fire hazard from the coil connections and ignition harness forward of these shields.

(10) On multiengine aircraft, the main **firewall** at the rear of the engine isolates engine fires to some extent from the remainder of the nacelle and from the wing structure. The rear of the engine nacelle may contain oil or hydraulic fluid tanks, a housing for retractable landing gear, or other equipment.

(11) Cowl flaps are installed near the **firewall** between the engine and accessory section. The

cowl flaps are important to a firefighter because they provide immediate access to the engine without removal of sections of the cowl surface. A CO<sub>2</sub> horn applicator nozzle may be placed at, or thrust through, the opening at the cowl flaps to quickly combat engine fires.

(12) When an engine is started or warmed up, a firefighter will stand to the rear of the propeller and be prepared to combat an engine fire through the cowl flaps. On emergency landings, the cowl flaps may be in the closed position. It may be faster to pry a flap loose with a small bar than a hole could be penetrated or a section of cowling removed.

(13) The most likely time for a fire to start is during engine starting because of the excessively rich fuel mixture settings. The fire can best be extinguished by the pilot turning off the fuel tank valves, moving the engine mixture controls to "idle **cutoff**", and allowing the engine to run itself out of fuel.

(14) *Some* reciprocating engine-driven aircraft have spring-loaded fire extinguisher access doors on the lower outside portion of the engine

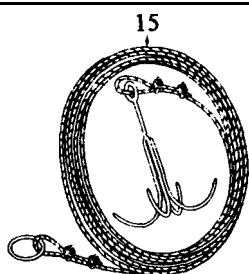
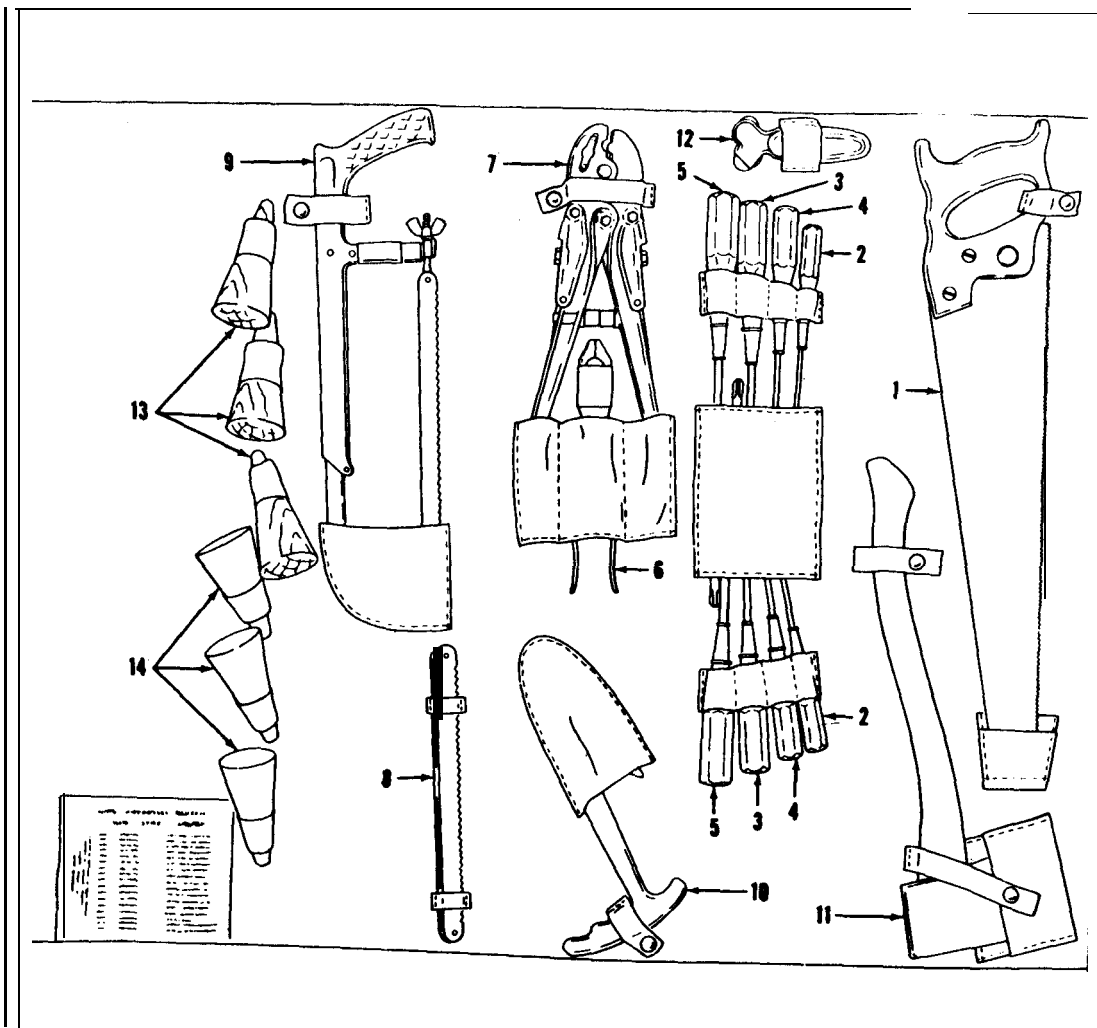

FEDERAL STOCK NO. 42 10-293-7666

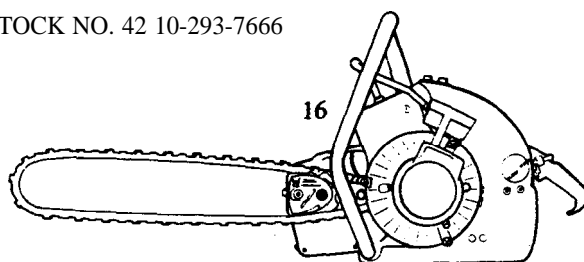

ITEM NO.	QUANTITY	DESCRIPTION	FEDERAL STOCK NO.
	1	METAL CUTTING SAW	G5110-221-0235
2	2	SCREW DRIVER, COMMON, 4-INCH	G5120-227-9491
3	2	SCREW DRIVER, COMMON, 8-INCH	G5120-277-9494
4	2	SCREW DRIVER, PHILLIPS, 4-INCH	G5120-236-2133
5	2	SCREW DRIVER, PHILLIPS, 8-INCH	G5120-236-21287
6	1	PLIERS, LINESMAN	G5120-239-825
7	1	CABLE CUTTER	R5110-224-7053-5231
8	6	HACK SAW BLADES	G5110-142-4928
9	1	HACK SAW FRAME	G51 10-2234971
10	1	"V" BLADE RESCUE KNIFE	RN51 10-524-6924
11	1	AXE	
12	1	DZUS WRENCH	
13	3	WOOD PEGS (SOFT)	
14	3	RUBBER PEGS	
15	1	GRAPNEL HOOK AND STEEL CABLE	
16	1	CHAIN SAW	

Figure 5-5. Crash rescue tool kit, chain saw, and grapnel hook.

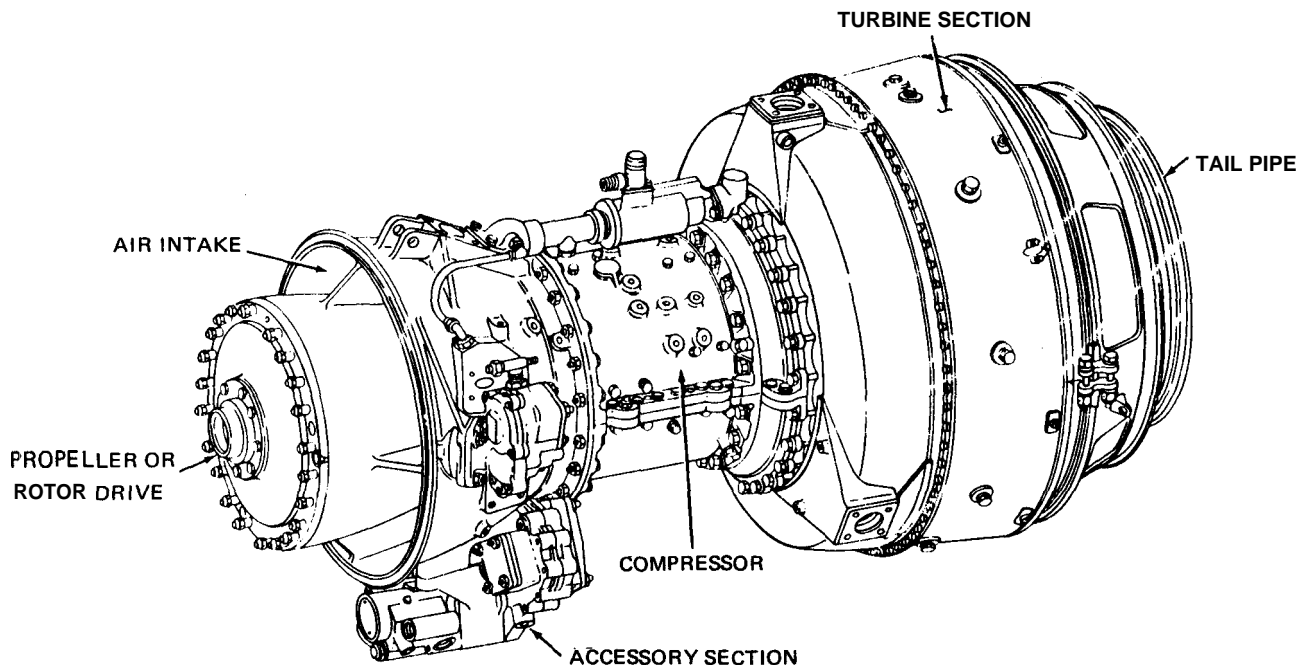

Figure 5-6. Gas turbine engine.

nacelles. These doors permit a fire extinguisher nozzle to be thrust directly into the accessory section of the engine. The doors are usually well labeled.

#### b. Gas Turbine Engines.

(1) A typical gas turbine engine (fig. 5-6) consists of an air intake, compressor, combustion section, turbine section, exhaust tailpipe, accessory section, and propeller or rotor drive.

(2) Short circuits in the electrical system or broken fuel and oil lines are major sources of fire. A firefighter will be prepared to immediately combat any electrical, oil, or fuel fire that occurs during ground operation of the aircraft or in the event of a crash.

(3) The firefighter will be on the alert for the possibility of an engine fire during starting and stoling of the gas turbine engine. If the engine is not started correctly, there is a tendency for fuel to drain or be pumped through the engine into the tailpipe or out the manifold drain onto the ground. A fire may start in the burned or turbine section after the throttle is closed. Should a fire occur, it can be extinguished by shooting  $\text{CO}_2$  or  $\text{CF}_3\text{Br}$  through the air intake duct or between the exhaust tailpipe and cowling.

#### NOTE

DO NOT DISCHARGE  $\text{CO}_2$  DIRECTLY INTO THE ENGINE EX-

#### HAUST BECAUSE IT MAY DAMAGE THE ENGINE.

(4) The gas turbine engine is separated into four sections which are potential fire zones: the inlet compressor, combustor (including the tailpipe), and the accessory section. When combating gas turbine engine fires, the firefighter should attempt to separate hot engine parts or other sources of ignition from fuel sources and the primary structure of the aircraft.

(5) Although very improbable, explosive mixtures may form in the accessory section from fuel leakage. Sparks from the generator or starter motor will supply the remaining element needed for an explosion or fire within the accessory section.

(6) The engine is separated from the aircraft by a shroud which is similar to a firewall. The shroud is pierced by necessary openings for cables, linkage, tubing, etc. The shroud is installed so that it seals at the forward bulkhead, at the forward end, and is vapor-tight throughout its length. It is highly improbable that the shroud will remain completely vapor- and liquid-tight after several removals and reinstallations during engine changes. The area surrounding an improperly sealed shroud becomes a hazardous area, in that there are generally many small pockets created by the stringers, ribs, and bulkheads of the nacelle in which fuels may collect and fill the zone



	<b>FUEL</b>		<b>HYDRAULIC PRESSURE OIL</b>
<b>RED</b>		<b>LT. BLUE-YELLOW-LT. BLUE</b>	
	<b>OIL (LUBRICATING)</b>		<b>AIR PRESSURE (COMPRESSED) MAX 20 PSI</b>
<b>YELLOW</b>		<b>LIGHT BLUE-LIGHT GREEN</b>	
	<b>COOLANT PRESTONE</b>		<b>AIR PRESSURE (COMPRESSED) MIN 25 PSI</b>
<b>WHITE-BLACK-WHITE</b>		<b>YELLOW-LIGHT GREEN</b>	
	<b>COOLANT WATER</b>		<b>STEAM</b>
<b>WHITE</b>		<b>LIGHT BLUE-BLACK</b>	
	<b>FIRE EXTINGUISHER</b>		<b>PURGING</b>
<b>BROWN</b>		<b>LIGHT BLUE-YELLOW</b>	
	<b>LOCATION EQUIPMENT</b>		<b>EXHAUSTANALYZER</b>
<b>LIGHT BLUE</b>		<b>LIGHT BLUE-BROWN</b>	
	<b>OXYGEN DISTRIBUTION</b>		<b>ANTI-ICING</b>
<b>LIGHT GREEN</b>		<b>WHITE-RED</b>	
	<b>OXYGEN FILLER</b>		<b>VENT (CLOSED COMPARTMENTS)</b>
<b>GREEN-YELLOW-GREEN</b>		<b>RED-BLACK</b>	
	<b>PITOT PRESSURE AIR SPEED</b>		<b>SMOKE SCREEN EQUIPMENT</b>
<b>BLACK</b>		<b>BROWN-WHITE</b>	
	<b>STATIC PRESSURE AIR SPEED, ALTIMETER, CLIMB INDICATOR</b>		<b>HOT AIR DUCTS CABIN HEATERS</b>
<b>BLACK-LIGHT GREEN</b>		<b>LIGHT BLUE-RED</b>	
	<b>MANIFOLD PRESSURE</b>		<b>COLD AIR DUCTS CABIN HEATERS</b>
<b>WHITE-LIGHT BLUE</b>		<b>YELLOW-RED-YELLOW</b>	
	<b>MANIFOLD PRESSURE LINE TO FUEL TANK PRESSURE UNIT</b>		<b>FUEL-AIR VAPOR SUPPLY LINES TO COMBUSTION TYPE CABIN HEATERS</b>
<b>RED-YELLOW</b>		<b>LIGHT GREEN-RED</b>	
	<b>VACUUM</b>		<b>EXHAUST LINES FROM COMBUSTION TYPE HEATERS</b>
<b>WHITE-LIGHT GREEN</b>		<b>BROWN-RED</b>	

Figure 5-7. Identification colors for aircraft tubing.

with flammable vapor. The zone generally has no ignition sources of its own. Ignition occurs from heat or flame entering the zone through the same path used by fuel or vapors, and a violent explosion may result.

(7) Fires are caused when improper engine starts spill fuel into the tailpipe. The fuel dropped onto the shroud runs forward, leading through the shroud joints into the area between the fuselage skin and the shroud. When the engine is started, flame or hot gases from the end of the tailpipe may ignite the fuel which has leaked between the shroud and skin.

### 5-8. Color Codes

*a. Identification of Tubing.* To simplify identification and tracing of cables, conduits, and tubing of approximately the same size, a standard marking system has been devised. It consists of color bands in various **combinations**, each color combination indicating a specific type of equipment. The color code system used for tubing on all aircraft is shown in figure 6-7. Colored bands are applied to the tubing and cables on **both** sides of all points of connection and passage through bulkheads or sheaths. Where long runs of unjoined tubing occur, there may be color bands at intermediate points for identification.

*b. Significance of Color Codes in F&refighting.* Color codes provide a means for immediate **recognition** of tubes and cables vital to firefighting. The contents of tubing carrying such fire hazards as fuel, oil, anti-icing fluid, or oxygen can be promptly determined by firefighters familiar with color code designations. Color codes aid in tracing sources of leaks or ruptures in the tubing so that either a cutoff valve may be closed or the flow may **be** stopped by other means.

### 5-9. Fuel System

Fuel is the principal fire hazard in aircraft. The fuel system of an aircraft stores and transfers fuel to the engine or engines. Fuel tanks, fuel lines, valve controls, pumps, and other component parts of the fuel system are widely dispersed throughout the structure of an aircraft. An outlet for escape of vapor or fuel may be produced by impact, twist, or movement of the aircraft or by improper assembly or maintenance. Ruptures in the fuel system are hazardous because of the existence of possible sources of ignition, such as **overheated** metal surfaces, exhaust gases, electrical connections, discharge of static electricity, etc.

Fuel vapors may be ignited by engine heat sources from **15** to 30 minutes after a fuel spill unless proper preventive action is taken by the firefighters.

a. Permanent fuel tanks are located in the wings or central fuselage. Permanent tanks may be in units separate from the aircraft framework, permanently built into the aircraft framework, or structurally part of the aircraft framework. As part of the permanent tank installations, a reserve supply of fuel is usually provided for emergency use. The reserve supply is separate from, and should not be confused with, the auxiliary fuel supply.

b. Reserve fuel is provided by separate tanks or by the installation of a standpipe or small **open**-topped tank within the main tank. The outlet from the reserve section of the tank is separate from the main tank outlet. Fuel from the reserve section is obtained by the operation of a selector valve. The importance of the reserve tank in **fire**-fighting is that the main tank may indicate empty, yet within the same tank the reserve section may be full, creating a fire hazard.

c. Auxiliary fuel tanks are frequently installed so that they can be dropped from an aircraft as soon as the fuel is exhausted. Auxiliary tanks not intended to be dropped in flight are installed in cargo space or wings. Because of the location of auxiliary tanks, they are usually vulnerable and highly hazardous in crash landings.

d. Pilots are instructed not to permit fuel tanks to run dry, but to change from a nearly empty tank to a full tank. Normally, no fuel tank will be completely drained. A mixture of fuel vapor and air, drawn into the tank through the vent opening, will be present and may be in such proportions as to create a flammable or explosive mixture.

e. Connections between fuel tanks of a **multi**-tank system are by direct openings in the tank walls or by tubing connecting the separate outlets. Fuel supply lines do not go directly from tank to engine, but pass through the wing or fuselage, or both, to control or selector valves at or near the pilots position. From the control or **selector** valves, the fuel lines go to the engine or engines. Tubing for venting and overflow extends from the tank interior to an outboard discharge point. The location of these outlets may be detected by **open**-end tubing extending just **beyond** the exterior

surface and by adjacent stenciled description. A manually operated drain valve is frequently mounted below the tank to permit daily withdrawal of water and sediment from the tank bottom. During tank filling, draining, or overflow due to expansion of fuel within a filled tank, liquid fuel or vapor may discharge from these outlets and remain on the ground surface. These discharges are a constant fire hazard.

*f.* A selector valve permits the selection of the fuel tank desired for engine fuel supply or completely cuts off the fuel supply from the engine or engines. The selector valve may have an indicating dial showing two OFF positions. Either position cuts off the fuel supply from engine or engines.

*g.* In firefighting operations, it may become necessary to isolate the fuel supply to each engine in an effort to determine the source of fuel flow. This can be done by placing the cross feed valve, located adjacent to the pilots position, in OFF position. When switched to ON position, the discharge lines of the two main fuel pumps are interconnected and the pump remaining in operation supplies fuel to both engines.

*h.* The main fuel pump is engine driven and is located in the accessory section. A booster pump is an auxiliary fuel pump in the fuel line at some point between the fuel tank and the main fuel pump. Booster pumps may be manually or electrically operated. Switching the master or the booster pump switch to **OFF** will shut off the booster pump. The priming pumps are used to supply fuel to the cylinder head or manifold for engine starting. Excessive priming is a cause of fires during engine starting. Liquid fuel or rich vapor may be discharged into the exhaust system and ignited, or ignite in the cylinder and return through the intake, spreading flame through the induction system to the carburetor and air scoop.

*i.* Carburetor, throttle, and mixture controls are usually mounted on the control quadrant. If the engine is still running after a crash, the fuel supply can be cut off on float type carburetors by moving the mixture control to the **IDLEOFF** position. On injection fuel systems the fuel may be cut off by moving the mixture control to the **MAXIMUM LEAN** position, or by placing the idle cutoff switch in the OFF position, depending on the type of fuel injection **system**.

## 5-10. Oil System

*a. Lubricating Oil.* Lubricating oil commonly

used for aircraft engines has viscosity ratings corresponding to SAE No. 40, 50, and 60. These oils do not vaporize at ordinary temperatures and their ignition temperature is higher than that of fuel; therefore, the fire hazard is relatively less than that of fuel. When lubricating oil is combined with fuel, as frequently happens in aircraft crashes, the fuel is readily ignited. The heat from the ignited fuel vaporizes and ignites the oil, producing an intense flame. The high viscosity of oil makes it more difficult to remove from a surface or from saturated debris. While oil is most readily ignited when combined with fuel, oil alone may be ignited by contact with hot engine parts, arcing electrical connections, or other sources of high temperature.

*b. Oil Tanks.* Tanks are of metal construction, ranging in capacity from 1 gallon (3.785 liters) to 45 gallons (170.3 liters). The oil tank may be located at various points in the wings or fuselage, but most commonly is immediately to the rear of the engine accessory section, just forward of the rear firewall. Filler necks and level cocks are installed on the tank for filling and determining oil level within the tank. The location of the filler neck is indicated by stenciling on a nearby surface.

*c. Oil Cooler.* Many aircraft engines have oil coolers to lower the temperature of the oil in high temperature operation. The most common type of cooler is a system of tubes or a cellular radiator through which the oil is circulated. This cooler is usually located within the engine nacelle.

*d. Oil Pump.* The oil pump is in the accessory section of the engine and is engine driven. Normal operating pressures do not usually exceed 100 psi (7 kilograms per square centimeter) and may be much less. Pressure is indicated by a gage on the pilot's instrument panel.

## S-1 1. Oxygen System

All aircraft intended for operation at high altitudes are equipped with breathing *oxygen* for each crew member and passenger. Oxygen lines run from a permanently mounted storage tank, or tanks, to crew and passenger positions.

### *a. Tanks, Tubing, and Controls.*

(1) The actual quantity of oxygen carried on an aircraft is of only secondary interest to the **firefighters**. They must be as cautious with a small quantity as with a large quantity.

(2) Oxygen storage tanks usually are painted

green. Tubing from main oxygen storage tanks to outlet stations generally contains oxygen at all times. Master control valves normally are kept in the open position.

(3) Oxygen is stored up to 1,800 psi (126 kilograms per square centimeter). This pressure exists throughout the distribution tubing system down to the outlet stations. Rupture of tubing anywhere between these points will free oxygen under high pressure.

#### **b. Fire Hazard.**

(1) Two hazards might occur from oxygen equipment : explosion, and released oxygen feeding the fire.

(a) Explosion may occur from rapid heating and expansion of the cylinders or from any traces of grease or oil that may come in contact with oxygen. The explosion may disrupt other equipment and cause a fire by breaking fuel lines, electrical cables, etc.

(b) Release of oxygen during a fire results in acceleration of burning and great intensity of heat. Escape of oxygen during crash fires results in rapid spread of fires and resistance to extinguishing agents.

(2) Every precaution must be taken to protect oxygen equipment from damage during forcible-entry operations, and if possible, to protect oxygen from exposure to heat or fire. Firefighters should be familiar with the location and operation of oxygen master control valves, and if possible, should close these valves during fire.

#### **WARNING**

DO NOT HANDLE OXYGEN EQUIPMENT OF ANY KIND WITH GREASY OR OILY RAGS OR HANDS. OXYGEN UNDER PRESSURE, IN CONTACT WITH GREASE OR OIL, WILL CAUSE AN EXPLOSION OR FIRE.

### **5-12. Electrical System**

The electrical system on an aircraft supplies current for lights, booster pumps, hydraulic pumps, propeller or rotor pitch gears, electronic equipment, etc.

#### **a. Electrical Wiring.**

(1) All aircraft have an extensive wiring system. The principal fire hazard is the danger of a short circuit or arcing.

(2) In a crash, it is probable that a large number of electric wires will be torn apart or damaged. Movement of an aircraft after a crash may produce a spark large enough to ignite fuel vapors. A crashed aircraft should be moved only when necessary for rescue operations, or when a fire is of such proportions that the additional danger from a short circuit is immaterial.

#### **b. Batteries.**

(1) The location of batteries varies with the type of aircraft. The batteries may be in the fuselage, wings, or engine nacelles. Special equipment, such as certain types of radar, is provided with separate batteries. These auxiliary batteries are not usually located in the same compartment as the main batteries.

(2) Before an aircraft is moved after a crash or after a fuel spill, disconnect the batteries and tape the leads, if possible, as a precautionary measure against arcing or short circuits. The proper way to disconnect a battery is to disconnect the ground wire first in order to eliminate the danger of arcing. Improper disconnection may produce an arc that will ignite fuel vapors.

#### **c. Ignition.**

(1) On reciprocating engine aircraft, the ignition switch usually means the magneto switch. In almost all reciprocal engines the ignition switch is operated by magnetos. Most aircraft are equipped with dual magnetos.

(2) If the aircraft engines are not running after a crash or fuel spill, the position of the ignition switch is of no importance to firefighters since the magnetos are driven by the engine and stop when the engine stops. If the engine is running after an accident, it is usually safe from a fire hazard viewpoint to stop the engine by first cutting off the fuel at the mixture control or fuel valve before cutting off the ignition switch. The ignition switch usually is separate from the master switch. Aircraft fire rescue personnel should always check the position of the master switch and beware of a hot magneto. A "hot mag" can cause the engine to fire even if the master switch is in off position.

(3) The battery switch usually is referred to as the master switch. The master switch is the principal electrical switch on an aircraft. All electrically operated units are connected to the power source through the master switch. The master switch is independent of separate equipment switches and may be used to cut off electric current simultaneously from all cables and equip-

ment. In a crashed aircraft and in case of fuel spill, it is important that the master switch is immediately placed in OFF position.

**d. Auxiliary Powerplants.**

(1) Some aircraft have auxiliary powerplants which are used to start the aircraft engine or engines. The auxiliary powerplants may be operated after takeoff to furnish an additional source of electrical power. The unit consists of an engine and an engine-driven generator.

(2) There is little fire hazard from the auxiliary powerplant electrical equipment but a fire hazard exists because of the engine. The auxiliary powerplant generator is mounted on the engine.

5-13. Anti-Icing System

**a.** The anti-icing system prevents the formation of ice on the propellers, carburetor, and windshield. For propellers and windshield, nonflammable fluids are used in combat zones, but in non-combat zones, alcohol (85 percent) and glycerine (15 percent) are used. For the carburetor, alcohol alone is used.

**b.** Locations and sizes of tanks containing anti-icing fluids vary with the type of aircraft. Separate tanks are provided for alcohol and alcohol-glycerine mixtures. Tubing extends from the tank to the forward part of the aircraft.

**c.** To prevent icing of propellers, anti-icing fluid is pumped from the tank to a slinger ring at the base of the propeller. The liquid then runs down the blades by centrifugal force. A similar arrangement is used to prevent icing of windshields. Icing of a carburetor occurs inside the carburetor; therefore, alcohol is routed directly to the carburetor and mixed with the fuel.

**d.** The fire hazard of anti-icing fluids is less than the fire hazard of aircraft fuel, but they should be treated with caution in the event of an aircraft crash. The most important points for the firefighter to know are the location of tanks, and the fact that the tank and tubing carry flammable liquids.

5-14. Heater System

In the combustion type heater, a fuel vapor-air mixture is burned in a hermetically sealed chamber. Fuel for the heater is routed from the main fuel system to the heater. The heater is usually located in the center fuselage section. The fuel vapor-air mixture is ignited by an electric igniter,

and is controlled by the heater control panel. The fire hazard from the combustion type heater results from the small quantity of fuel vapor-air mixture present in the heater.

5-15. Crew Entrapment

The controls for ailerons, rudder, elevators, trim tabs, rotors, and rotor blades are usually in the form of cables, mechanical levers, or rod linkages which pass from the pilot's position through the wings or fuselage to the control surfaces. These controls are actuated by a pilot's control stick or a wheel and drum type control. A crash will sometimes jam the cables or mechanical linkages in a fixed position, so that the control stick or wheel pins the pilots within the pilot's compartment. In such cases it may be necessary to cut the cables or mechanical linkages in order to release entrapped personnel.

5-16. Rockets

Rockets still on their launchers are extremely dangerous. Every precaution should be taken to stand clear both fore and aft of rocket installations. Rocket flash which occurs upon ignition is usually fatal at short ranges behind the rocket. The auto-ignition temperature of solid rocket propellants is about 392° to 575° F. (200°—300° C.).

**a.** The effects of a propellant explosion are minor. The usual result is a split motor tube and an ejection of flame and gas from the motor through the nozzles and the split. The exhaust gases from the burning propellant are about 4,000° F. (2,204° C.) and will add to the intensity of the existing fire. If the high temperature gas is directed against the aircraft surface, penetration may occur. This adds to the fire hazard due to the fact that fuel tanks may be ruptured or fire spread to other sections of the aircraft.

**b.** Ignition of the propellant could cause the rocket to fire. The rocket will probably follow a normal path and be armed when it stops. Extreme care must be taken in handling rockets fired in this manner.

5-17. Pyrotechnics

**a.** Pyrotechnics are used for signals, warnings, lighting for photography, bombing or landing, or other special purposes. They consist of various types of flares, signal lights, smoke grenades, and similar devices.

b. Pyrotechnics contain rapid-burning powder, magnesium, or flammables which are readily **discharged** or ignited. Pyrotechnics may contain small explosive charges that will spread fire quickly throughout the aircraft.

c. Pyrotechnics may be located anywhere on the aircraft. In single-seated aircraft, hand-launched pyrotechnics are located conveniently for the pilot. Parachute flares are released by remote **con-**

**trols** located in the pilot's compartment and are normally carried in special compartments in the side of the fuselage.

d. Whenever possible, pyrotechnics should be promptly removed from a crashed aircraft. **Failure** to do so may result in the discharge of these flares and signals with great increase in the **intensity** of an existing fire, or in the ignition of a fire which otherwise might not have occurred.

### Section III. EMERGENCY PROCEDURES

#### 5-18. Traffic Pattern

a. The traffic pattern prescribes direction and altitude, **so that** aircraft **landing** or taking off will follow prescribed courses, thereby avoiding **confu-**

sion and collisions. The traffic pattern is shifted according to the direction of the wind. A typical traffic pattern is shown in figure 5-8.

b. Movement within the traffic pattern is **al-**

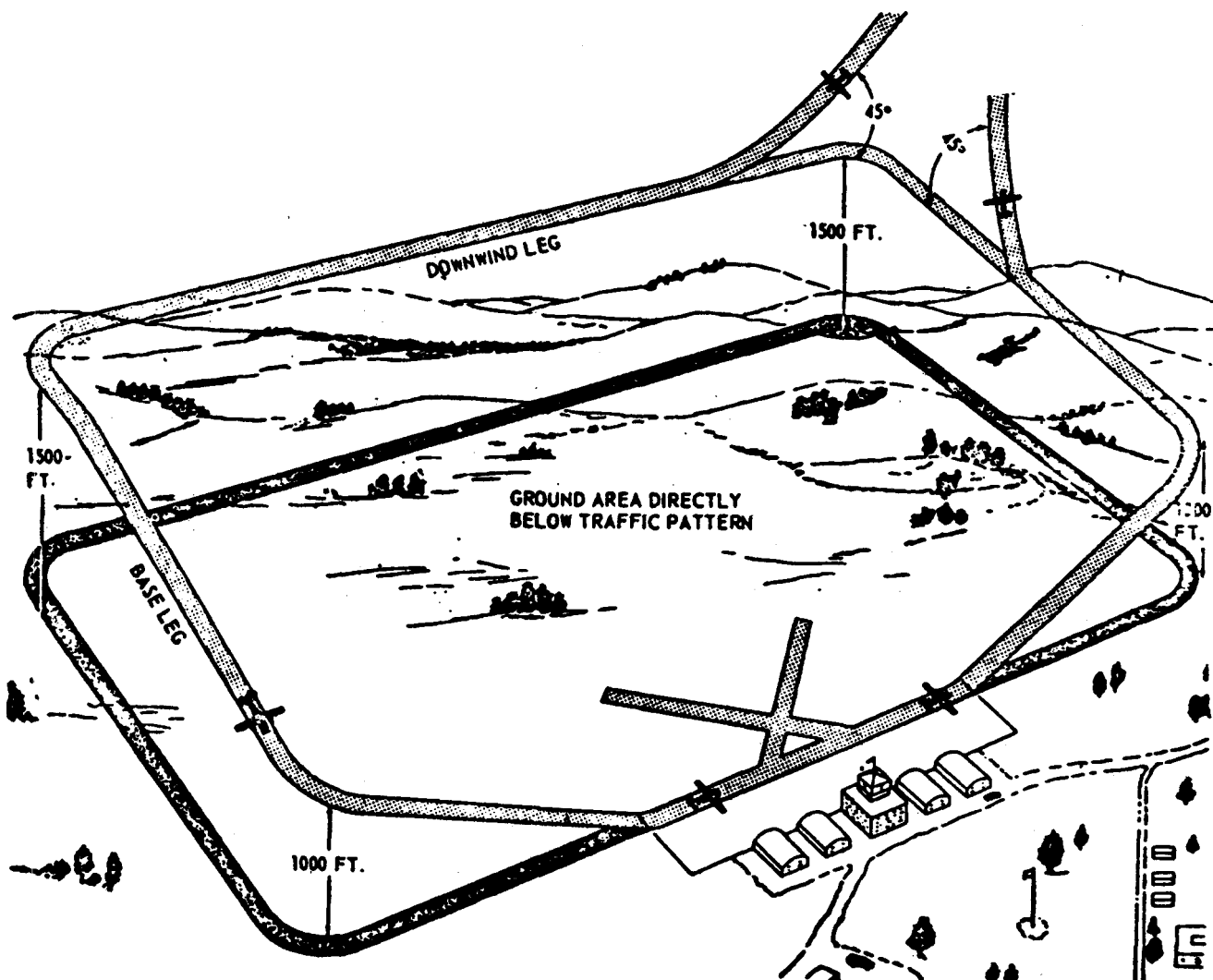

Figure 5-8. Typical traffic pattern.

ways in the same direction regardless of arrival or departure from the airfield, because landings and takeoffs are both made into the wind. A typical traffic pattern has dimensions of 3 miles (4.8 kilometers) at **1,500-foot** (457.5meter) altitude, but other dimensions and altitudes may be used, established according to local conditions.

c. The typical traffic pattern consists of a counterclockwise rectangular flow of aircraft about the airfield. One side consists of the runway, take-off leg, and approach leg along the line of the runway nearest the prevailing wind direction. The takeoff leg continues with a **90°** turn, which is crosswind. On the crosswind leg an aircraft departing the traffic pattern would turn **45°** away from the flow of traffic. To continue in the traffic pattern, another **90°** turn is then made and this places the aircraft parallel to the runway and forms the downwind leg. An aircraft arriving at the airfield would enter the pattern at a **45°** angle to the downward flow of traffic. The landing aircraft continues with a **90°** turn, forming the base leg. At this point the aircraft normally begins to descend. The final **90°** turn is then made to place the aircraft in a position to land on the runway. The traffic pattern will occasionally be clockwise or as published by the airfield.

### **5-19. Coordination Between Military, Civil, and Municipal Organizations**

Coordination and cooperation between local military, civil airfield, and municipal firefighting organizations is most desirable. Mutual assistance agreements between responsible activities are encouraged. Local commanders should cooperate fully with Forest Service, state, and local fire officials in developing plans to furnish assistance in firefighting and rescue to an extent which would not impair the safety of the military installation involved.

### **5-20. Emergency Communications System**

a. An emergency aircraft rescue communications system must be provided to permit rapid and reliable notification of impending and actual aircraft accidents to firefighting and rescue crews, ambulance crews, and other personnel requiring such notification. The system must be capable of conveying full initial information on the emergency so that crash trucks and ambulances can be dispatched quickly and efficiently. The system must also provide continuing intercommunication between mobile units and the fixed control stations throughout the emergency.

b. A complete emergency communications system should consist of the following:

(1) Principal fire truck and ambulance fixed control stations.

(2) Provisions for monitoring communications between aircraft and control tower.

(3) Direct emergency wire intercommunication between control tower and principal crash truck and crash ambulance fixed control stations.

(4) Secondary emergency telephone or similar wired system for notifying essential supporting personnel.

c. Operation of the two-way radio sets is simplified to the extent that the driver of the fire truck can operate them. A qualified radio operator is not necessary.

### **5-21. Training**

Maintenance, refueling, and servicing personnel on the flight line, supporting aircraft operation, will be instructed in the types of extinguishers and their operation, care, and proper application of extinguishment of fires. Firefighters assigned to aircraft fire rescue work must become thoroughly familiar with and have a working knowledge of the requirements contained in AR 95-26 and AR 95-1.

### **5-22. On-The-Airfield Emergency**

Normally the control tower operator will obtain the first information of impending emergencies or accidents. He immediately notifies the fire rescue crew of the situation, giving exact information on the location and status of the event together with any pertinent details. Upon receipt of this notification, all crash crews and ambulances on alert will respond immediately. If the situation is an impending emergency, they assume standby positions at predetermined locations alongside, but clear of, the runway.

#### **NOTE**

Notification by the control tower operator does not relieve fire rescue crews on alert of the responsibility of maintaining constant observation since, particularly during active flying periods, many instances may escape the initial notice of the tower operator.

### **5-23. Off-The-Airfield Emergency**

a. Maps of the installation and surrounding area of about **15-mile (24-kilometer)** radius

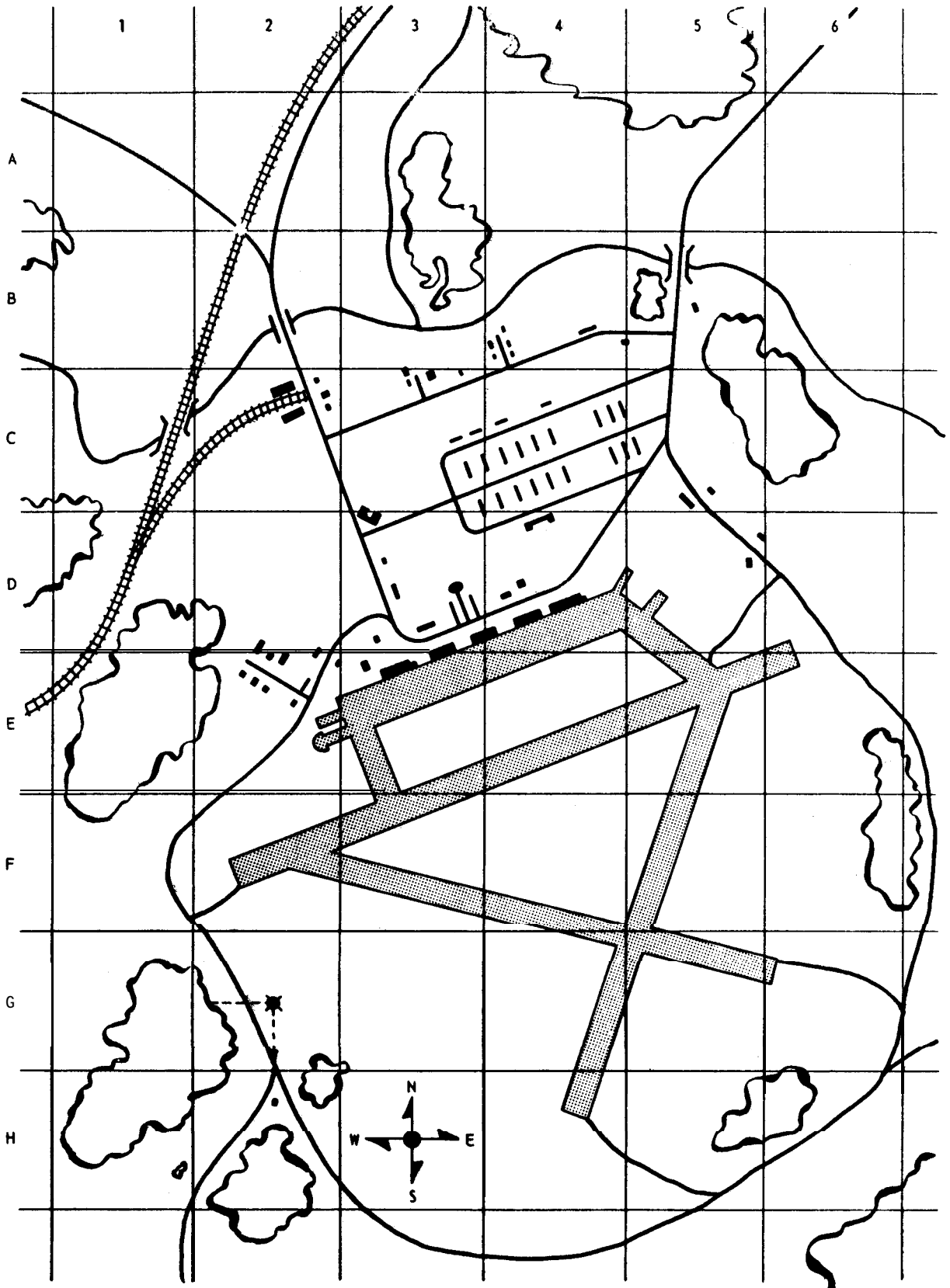

Figure 5-9. Grid map.



should be available. These maps should be ruled off in numbered grids, and compass headings marked on them generally as shown in figure 5-9. This will make it easier to locate any point within the map area.

**b.** When necessary, an aircraft will be used to locate and guide firefighting and rescue trucks to the scene.

**c.** Aircraft are guided by radio contact and visual and audible **signals**.

**d.** When not directing fire rescue trucks, **aircraft** will circle crashed aircraft until relieved, fuel supply permitting.

## 5-24. Emergency Rescue Procedures

### **a. Aircraft Entrances.**

(1) Depending on the aircraft model, entrance doors may be found on **either** side or both sides of the fuselage. They usually open outward and are hinged on the forward side so the **air-stream** tends to close the door. The opposite side is fastened by a latch which usually is operated by pulling the door handle. On most aircraft, an emergency release mechanism is installed **at** the hinge side of the door, and is operated by pulling the jettison handle.

(2) **Escape** hatches or escape panels, provided on some aircraft, are made either of **plexi-glas** or metal. The hatches usually have an external release handle with the location and operating procedures marked on the adjacent surface of the fuselage.

(3) Emergency cut-in areas, indicated by a broken yellow line, are provided on some aircraft. This marking is a safety guide which designates a comparatively obstacle-free area where tools used for cutting fuselage skin will not meet heavy structural members or rupture fuel, electrical, or oxygen lines that can cause additional fire or an explosion. Extreme care should be used when cutting fuselage skin to prevent sparks which might ignite fuel vapors.

(4) The aircraft may have other openings intended primarily for other specific purposes, but which may be used under certain circumstances for emergency entrance.

### **b. Rescue of Personnel.**

(1) After entrance is gained, the firefighters should first locate and determine the condition of injured personnel. If immediate hazards are beyond control, personnel should **be** evacuated immediately. If immediate evacuation is not possible

due to wreckage or twisted controls, the firefighters should attempt to keep the fire away from the area where personnel are trapped. Extreme care should be used when removing personnel pinned in wreckage to prevent aggravating existing or causing additional injuries. If possible, medical advice should be obtained before moving injured personnel.

(2) All Army aircraft have seat safety belts and many have shoulder harnesses. The safety belts and shoulder harness are constructed of very strong, webbed material and are difficult to cut; therefore, the rescuer should be familiar with the release procedures. The safety belt and shoulder harness (fig. 5-10) are released by unlocking the inertia reel and pulling up on the release handle. The inertia reel is unlocked by placing the inertia reel lock lever at the locked and then the unlocked position. If necessary, the safety belt and shoulder harness may be cut as shown in figure 5-11. Some aircraft, such as the **UH-1C** and **UH-1D** model helicopters, are equipped with **tilt-back** pilot and copilot seats to aid in extracting injured personnel from a crowded cockpit. These seats are identifiable by two red handles located at the back of each side of the seat. Both handles must be pulled down to tilt back the seat.

(3) After releasing the safety belt and shoulder harness, it may be necessary to remove the parachute from injured personnel. Three basic types of parachutes are used: the seat type, the **back** type, and the attachable chest type. These parachutes are strapped to the personnel by means of a parachute harness which may have either three clip-type fasteners or one quick-release box. The parachute harness with clip-type fasteners (fig. 5-12) is the most commonly used. The parachute harness may also have one or two parachute canopy release mechanisms in addition to the clip-type fasteners. The purpose of the release mechanism is to release the parachute canopy and not the entire harness. The release mechanism may be located either on the left-hand parachute canopy strap or on both straps. Typical parachute release mechanisms with operating procedures are shown in figure 5-13. The parachute harness equipped with the quick-release box provides a fast and efficient method of releasing the personnel, as shown in figure 5-14.

## 5-25. Portable and Fixed Fire Protection on Aircraft

Fire protection equipment installed on aircraft may consist of one or more portable fire **extin-**

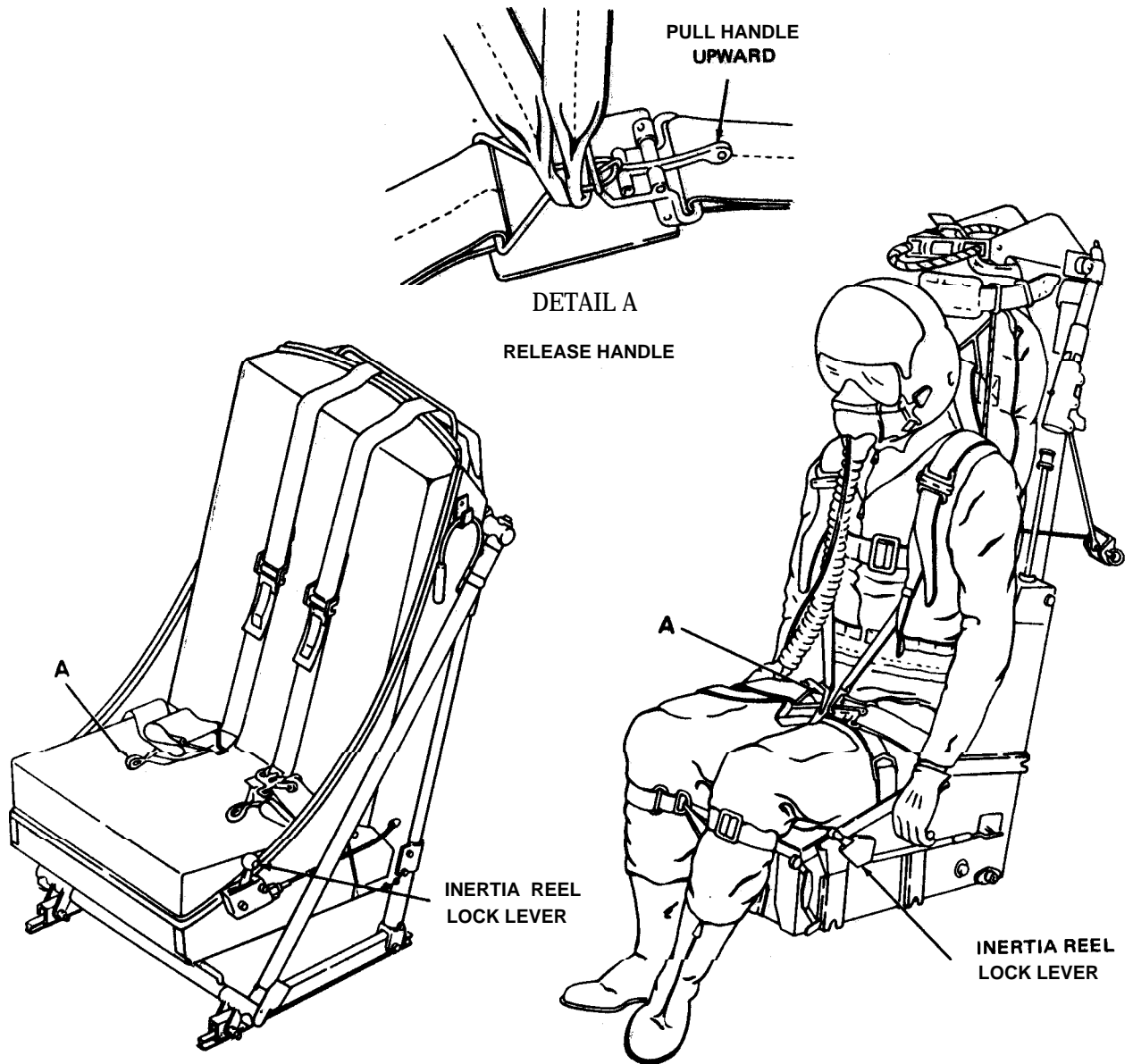

Figure 5-10. Safety belt and shoulder harness-typical.

guishers. On larger aircraft this protection may be supplemented by a fixed fire extinguisher system.

*a. Portable Fire Extinguishers.* Portable CF3Br fire extinguishers are mounted for quick access. They usually are located within the fuselage at or near crew member positions or adjacent to specific equipment hazards.

*b. Fixed Fire Extinguisher System.* The majority of fixed fire extinguisher systems are installed in multiengine aircraft and are usually the one-shot type. The system consists essentially of the following components:

- (1) One or more cylinders for storing extinguishing agent.
- (2) Distribution lines leading to protected areas.
- (3) Controls for releasing extinguishing agent.

5-26. Aircraft Familiarization

*a.* The different types of aircraft make the job of firefighting and rescue more complex. To carry it out successfully, the firefighter should be thoroughly familiar with the following :

- (1) Visual identification of various types of aircraft.

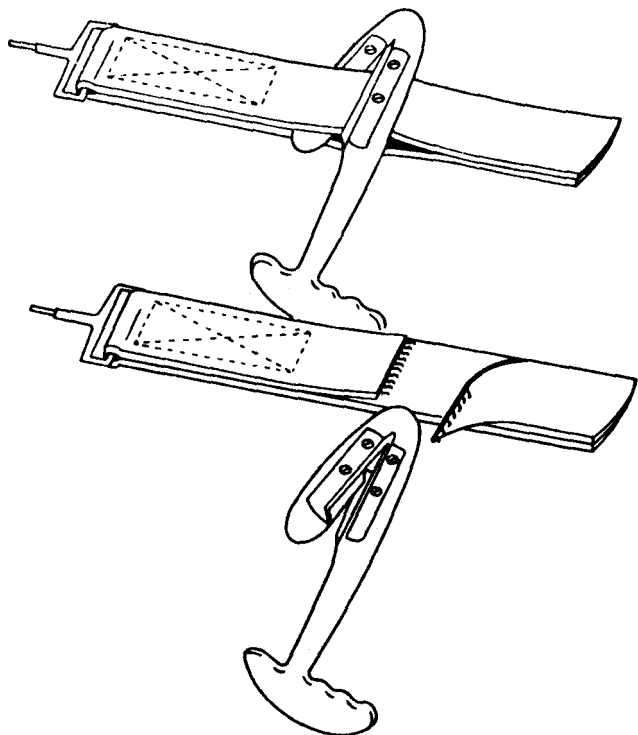

Figure 5-11. Method of cutting double harness.

- (2) Location of personnel and aircraft entrance points.
- (3) Fuel tank locations and capacities.
- (4) Oil tanks, hydraulic reservoirs, and anti-icing reservoir locations and capacities.
- (6) Battery location.
- (6) Oxygen cylinder location.
- (7) Basic features of ejection seat, its operation, and precautions necessary to prevent accidental ejection.
- (8) Preservation of evidence that could possibly aid in determining cause of accident.

b. To aid in this familiarization, figures 5-15 through 6-49 illustrate the general arrangement of standard Army aircraft and several Air Force aircraft, and the emergency procedures to be followed for each.

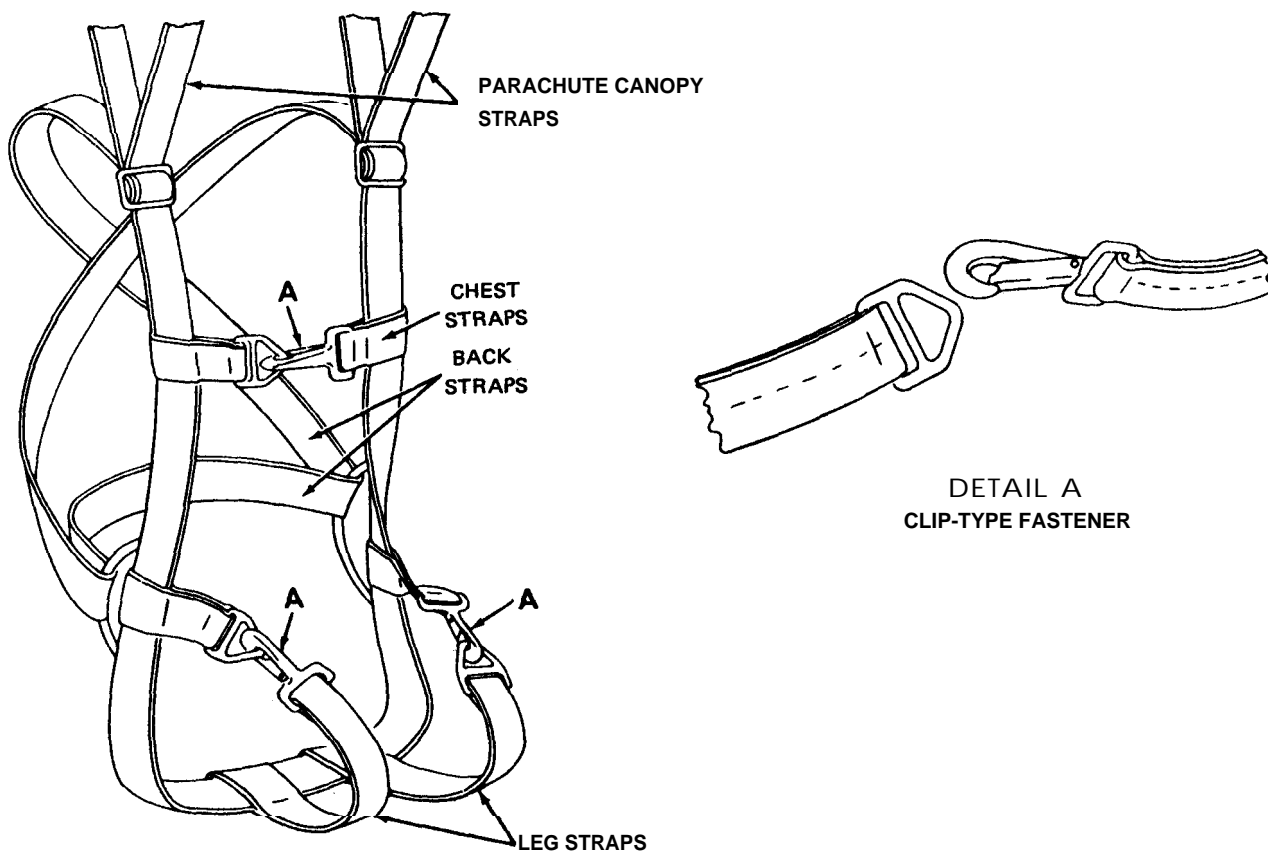

Figure 5-12. Parachute harness with clip-type fasteners.

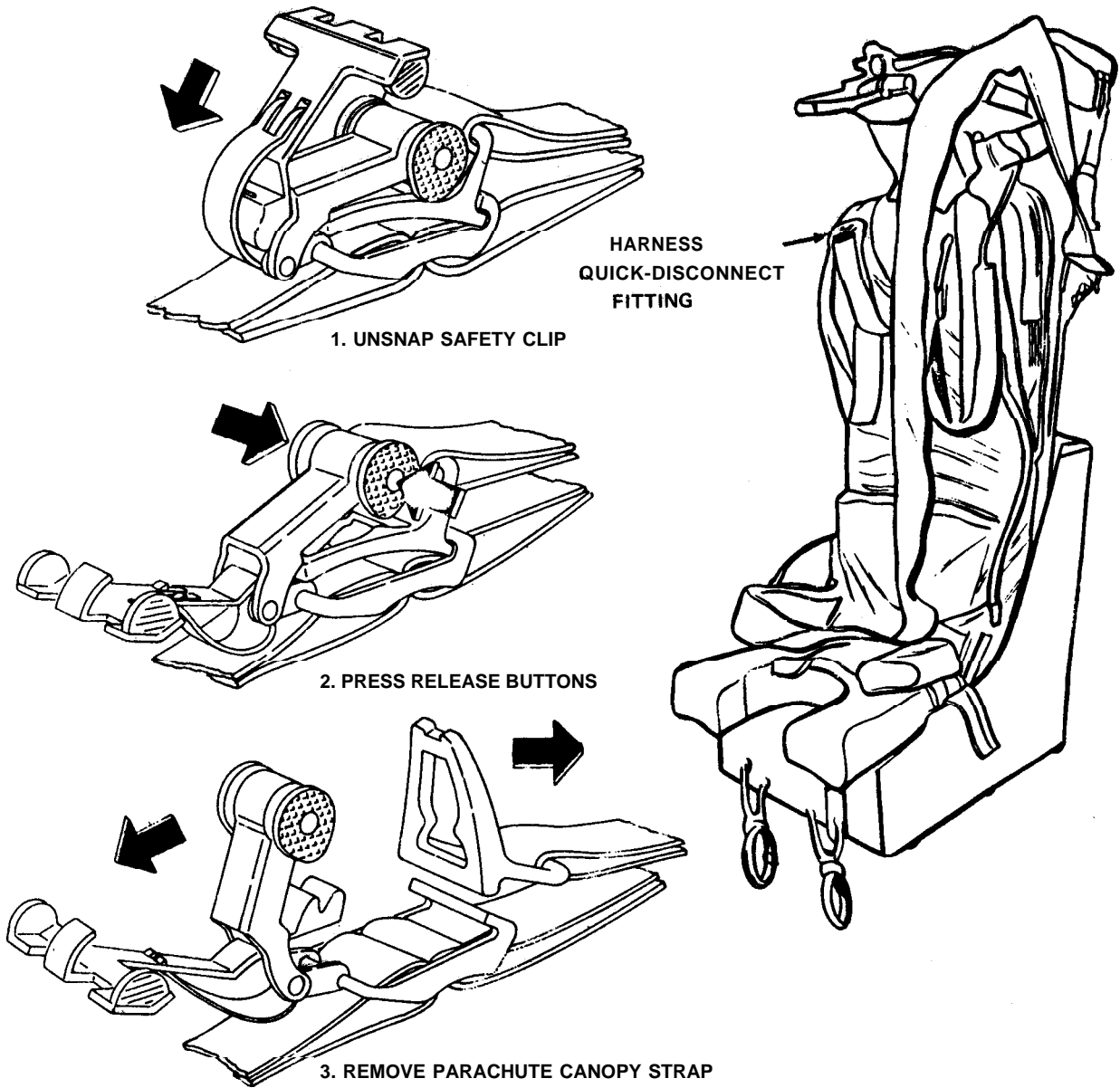

Figure 5-18. Parachute canopy release mechanism—typical.

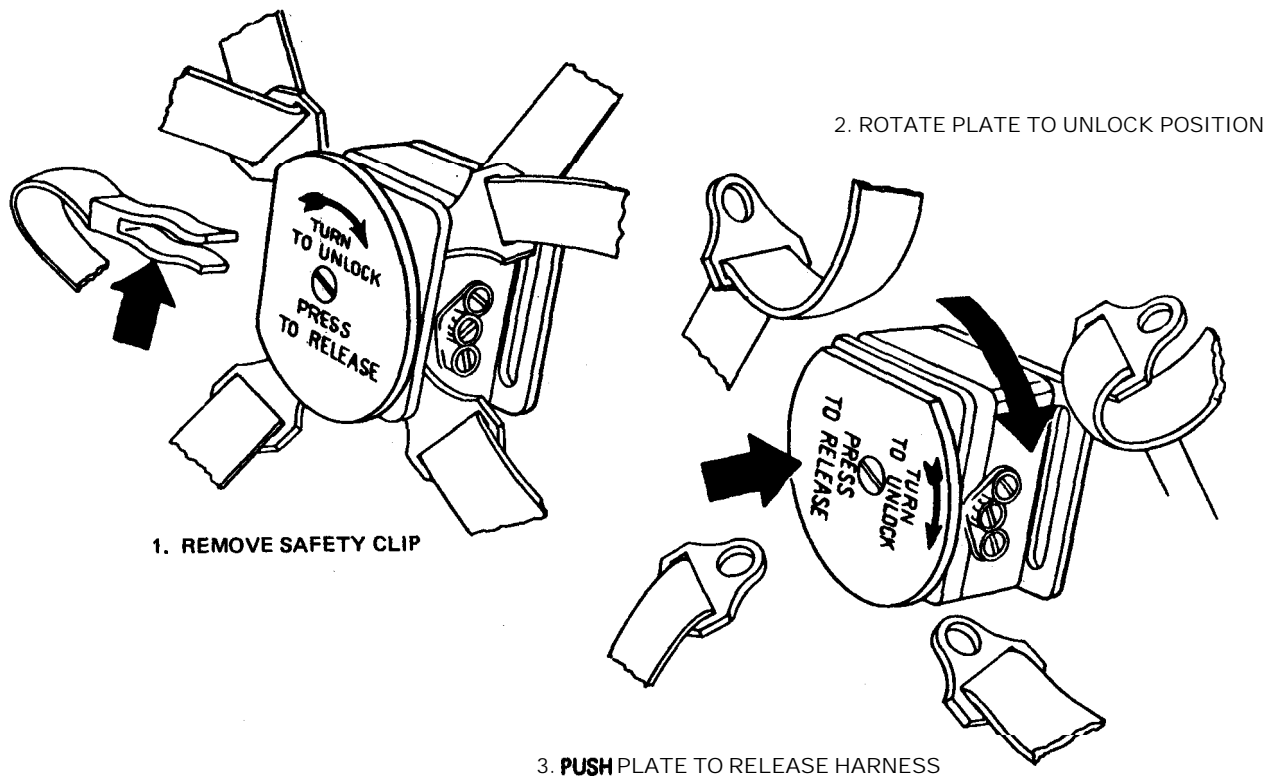

Figure 5-14. Parachute harness quick-release box.

GENERAL DESCRIPTION

TYPE - SINGLE ENGINE, HELICOPTER  
 CREW - 2  
 PASSENGERS - 3

DIMENSIONS (MAX) AND WEIGHT (GROSS)

LENGTH - 30 FT, 2 3/4 IN  
 WIDTH - 6 FT, 9 1/4 IN  
 HEIGHT - 8 FT, 6 IN  
 WEIGHT - 2163 LB

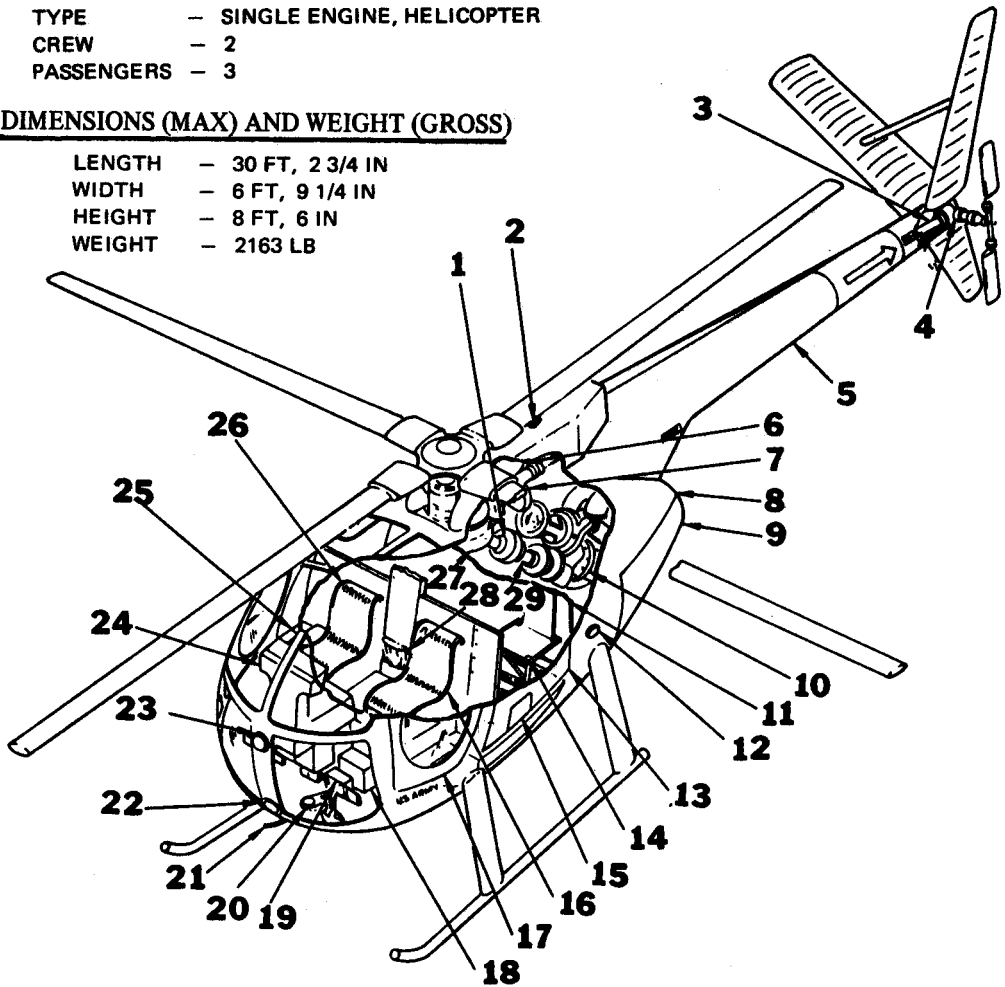

- |                               |                                    |
|-------------------------------|------------------------------------|
| 1. OIL COOLER 6LOWER          | 16. COPILOTS SEAT                  |
| 2. UPPER ANTICOLLISION LIGHT  | 17. LH PILOTS COMPARTMENT DOOR     |
| 3. TAIL ROTOR DRIVE SHAFT     | 16. RADIO AND NAVIGATION EQUIPMENT |
| 4. TAIL ROTOR TRANSMISSION    | 19. BATTERY                        |
| 5. TAIL BOOM                  | 20. LOWER ANTICOLLISION LIGHT      |
| 6. ENGINE OIL TANK            | 21. PITOT TUBE                     |
| 7. OIL COOLER                 | 22. LANDING/HOVER LIGHT            |
| 6. ENGINE EXHAUST PIPE        | 23. EXTERNAL AIR INLET             |
| 9. ENGINE ACCESS DOOR         | 24. INSTRUMENT PANEL AND CONSOLE   |
| 10. ENGINE                    | 25. EXTERNAL POWER RECEPTACLE      |
| 11. FIREWALL                  | 26. PI LO& SEAT                    |
| 12. LH NAVIGATION LIGHT       | 27. MAIN ROTOR TRANSMISSION        |
| 13. LH CARGO COMPARTMENT DOOR | 28. MAP CASE (CHECKLIST)           |
| 14. TROOP SEAT                | 29. MAIN DRIVE SHAFT               |
| 15. ARMAMENT ACCESS DOOR      |                                    |

Figure 5-15. Model OH-6A aircraft.

## EMERGENCY PROCEDURES

EMERGENCY ENTRANCE IS GAINED THROUGH CABIN DOORS AND PASSENGER DOORS. IF DOOR FAILS TO OPEN, BREAK WINDOWS OR CANOPY TO GAIN ACCESS TO DOOR JETTISON HANDLE,

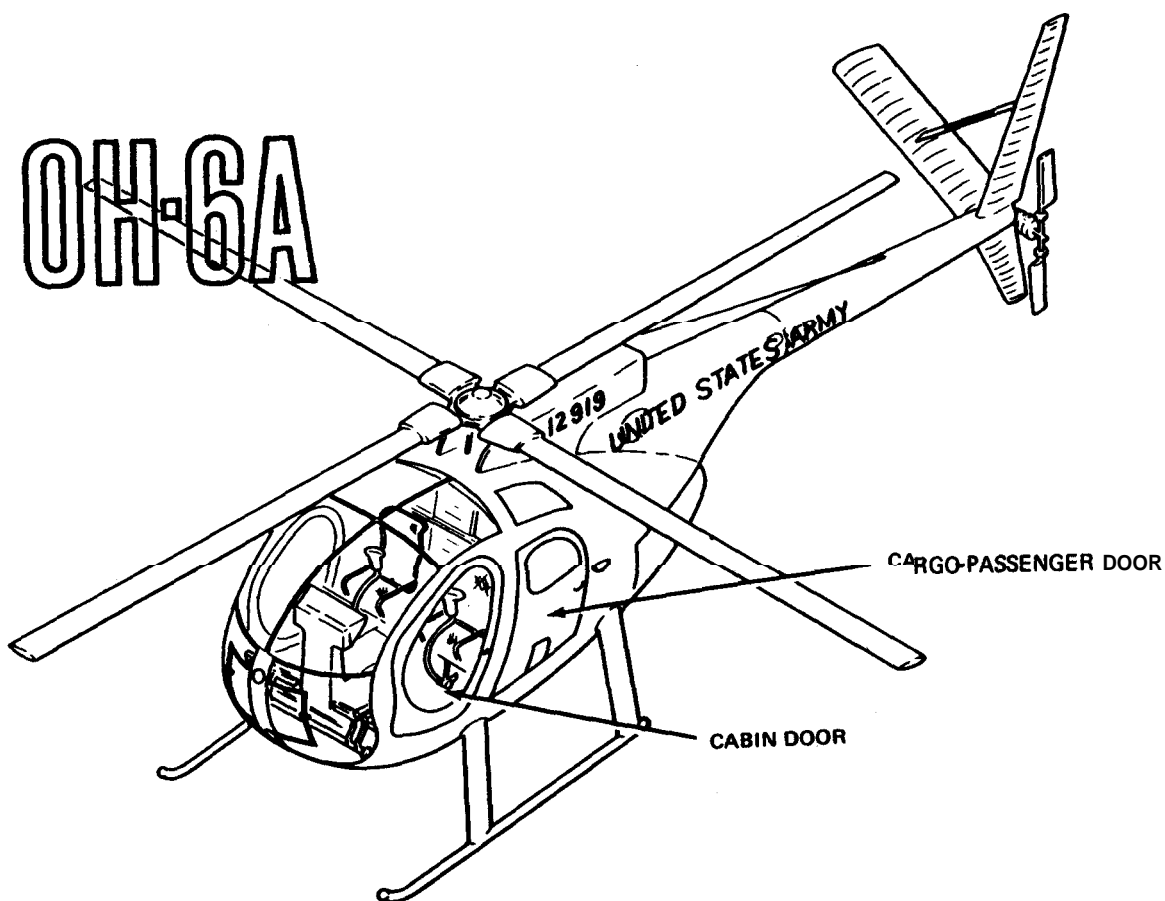

Figure 5-15. Model OH-6A aircraft—Continued.

**GENERAL DESCRIPTION**

TYPE - SINGLE ENGINE, HELICOPTER  
 CR&W - 2  
 PASSENGERS - 2

**DIMENSIONS (MAX) AND WEIGHT (GROSS)**

LENGTH - 40 FT, 4 IN  
 WIDTH - 6 FT, 5.5 IN  
 HEIGHT - 9 FT, 7 IN  
 WEIGHT - 2763 LB

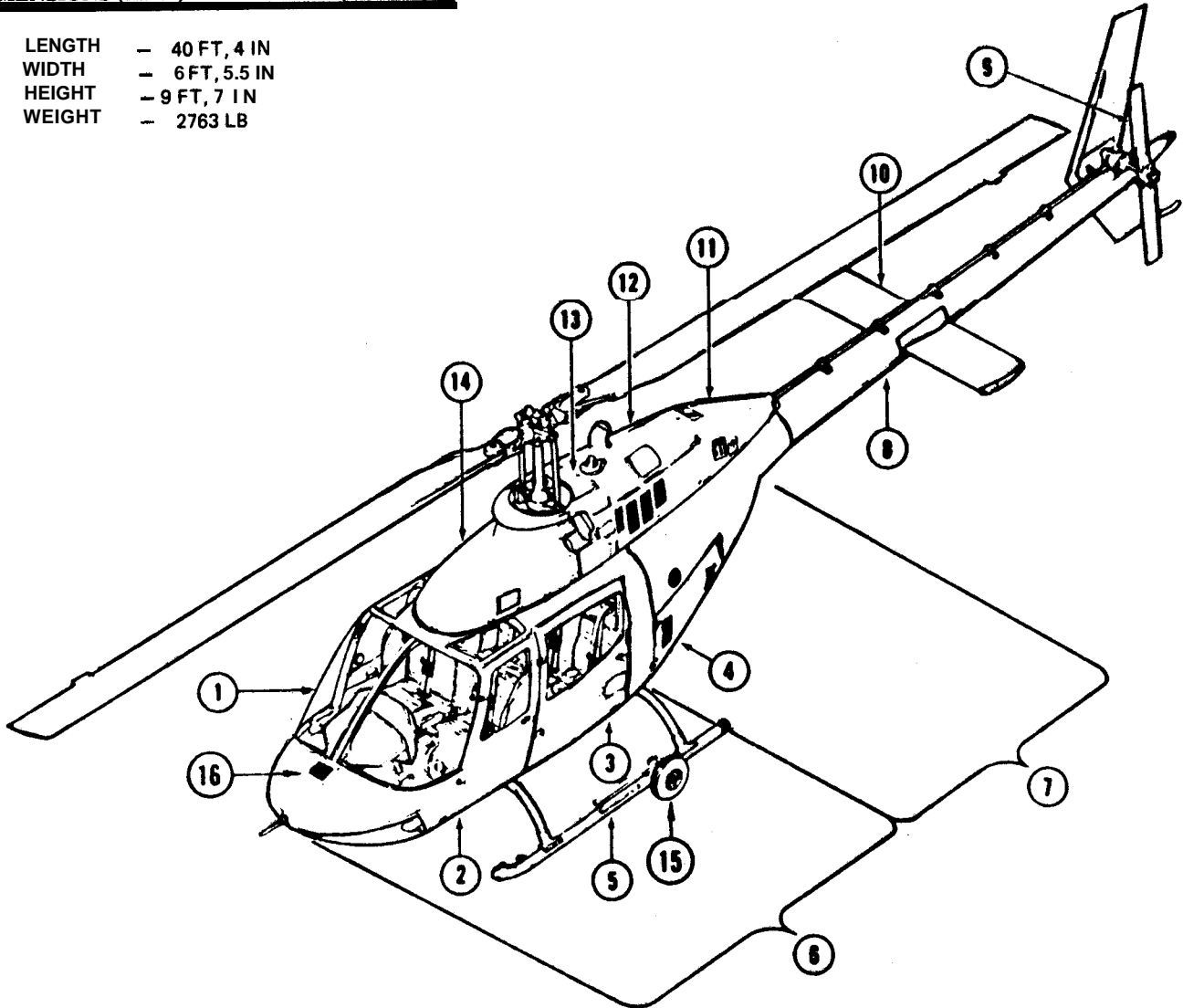

- |                             |                            |
|-----------------------------|----------------------------|
| 1. WINDSHIELD               | 9. TAIL ROTOR              |
| 2. CREW DOORS               | 10. HORIZONTAL STABILIZER  |
| 3. AFT CABIN DOORS          | 11. AFT FAIRING            |
| 4. AFT AVIONICS COMPARTMENT | 12. ENGINE COWL            |
| 5. LANDING GEAR             | 13. INDUCTION FAIRING      |
| 6. FORWARD SECTION          | 14. FORWARD FAIRING        |
| 7. INTERMEDIATE SECTION     | 15. GROUND HANDLING WHEELS |
| 8. TAIL BOOM                | 16. RAM AIR                |

Figure 5-16. Model OH-58A aircraft.



**EMERGENCY PROCEDURES**

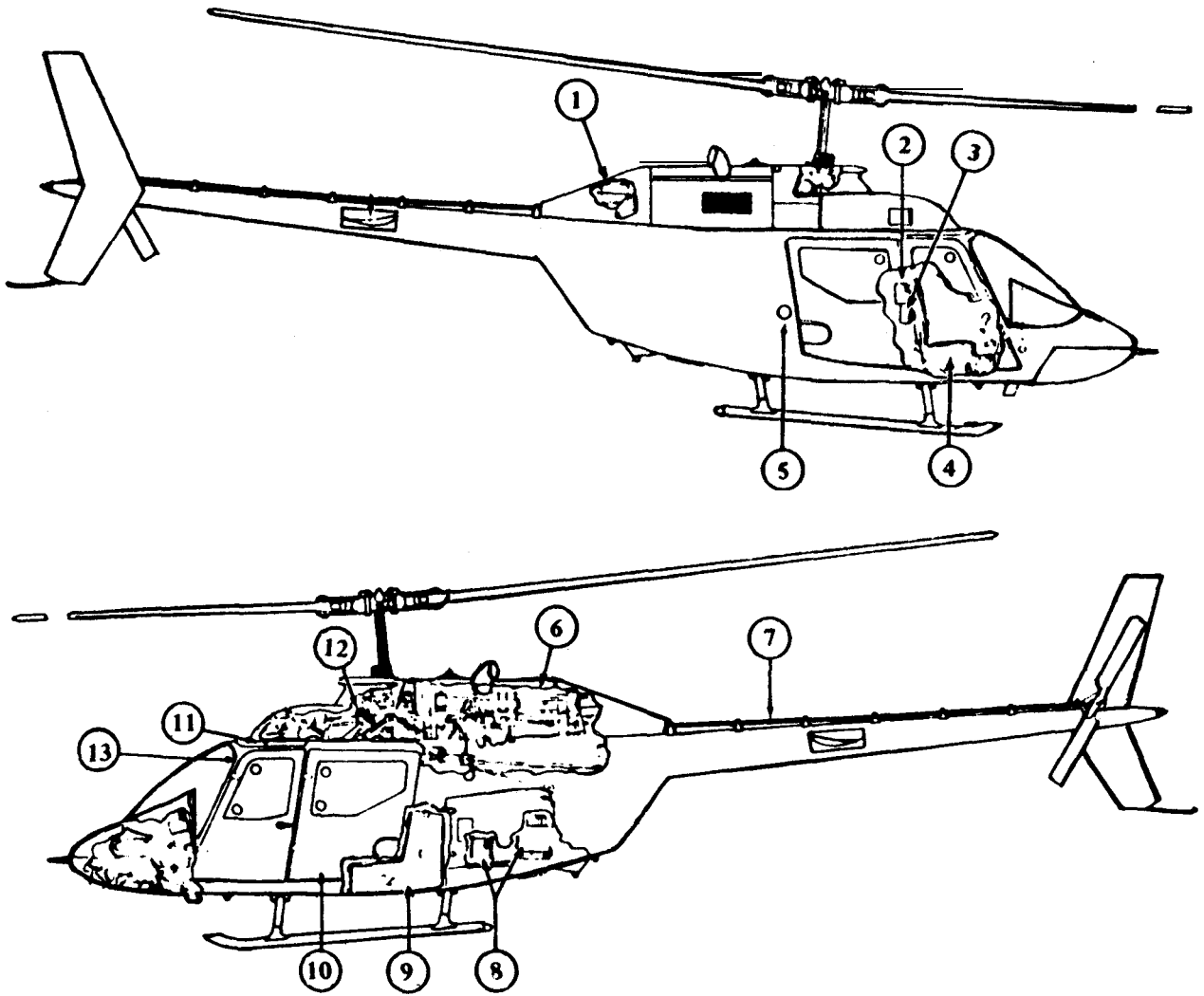

**EMERGENCY ENTRANCE**

EMERGENCY ENTRANCE IS GAINED THROUGH CABIN DOORS AND PASSENGER DOOR. IF DOOR FAILS TO OPEN, BREAK WINDOWS OR CANOPY TO GAIN ACCESS TO DOOR JETTISON HANDLE.

- 1. OIL TANK FILLER (1 1/2 GAL)
- 2. FIRST AID KIT
- 3. FIRE EXTINGUISHER
- 4. PILOT'S STATION
- 5. FUEL TANK FILLER
- 6. ENGINE
- 7. TAIL ROTOR DRIVE SHAFT (OPEN)
- B. BATTERY
- 9. FUEL CELL (73 GAL)
- 10. PASSENGER STATION
- 11. FUEL VALVE SHUT-OFF
- 12. HYDRAULIC PUMP AND RESERVOIR (2 PINTS)
- 13. MASTER SWITCH (CONSOLE)

Figure 5-16. Model OH-58A aircraft t-continued.

GENERAL DESCRIPTION

TYPE -- SINGLE ENGINE, HELICOPTER  
 CREW -- 2  
 LITERS -- 2

DIMENSIONS (MAX) AND WEIGHT (GROSS)

LENGTH -- 41 FT, 4.75 IN  
 WIDTH -- 35 FT, 1.5 IN  
 HEIGHT -- 8 FT, 8.15 IN (MODEL OH-13D)  
 -- 9 FT, 4.31 IN (MODEL OH-13E)  
 WEIGHT -- 1968 LB (MODEL OH-13D)  
 -- 2350 LB (MODEL OH-13E)

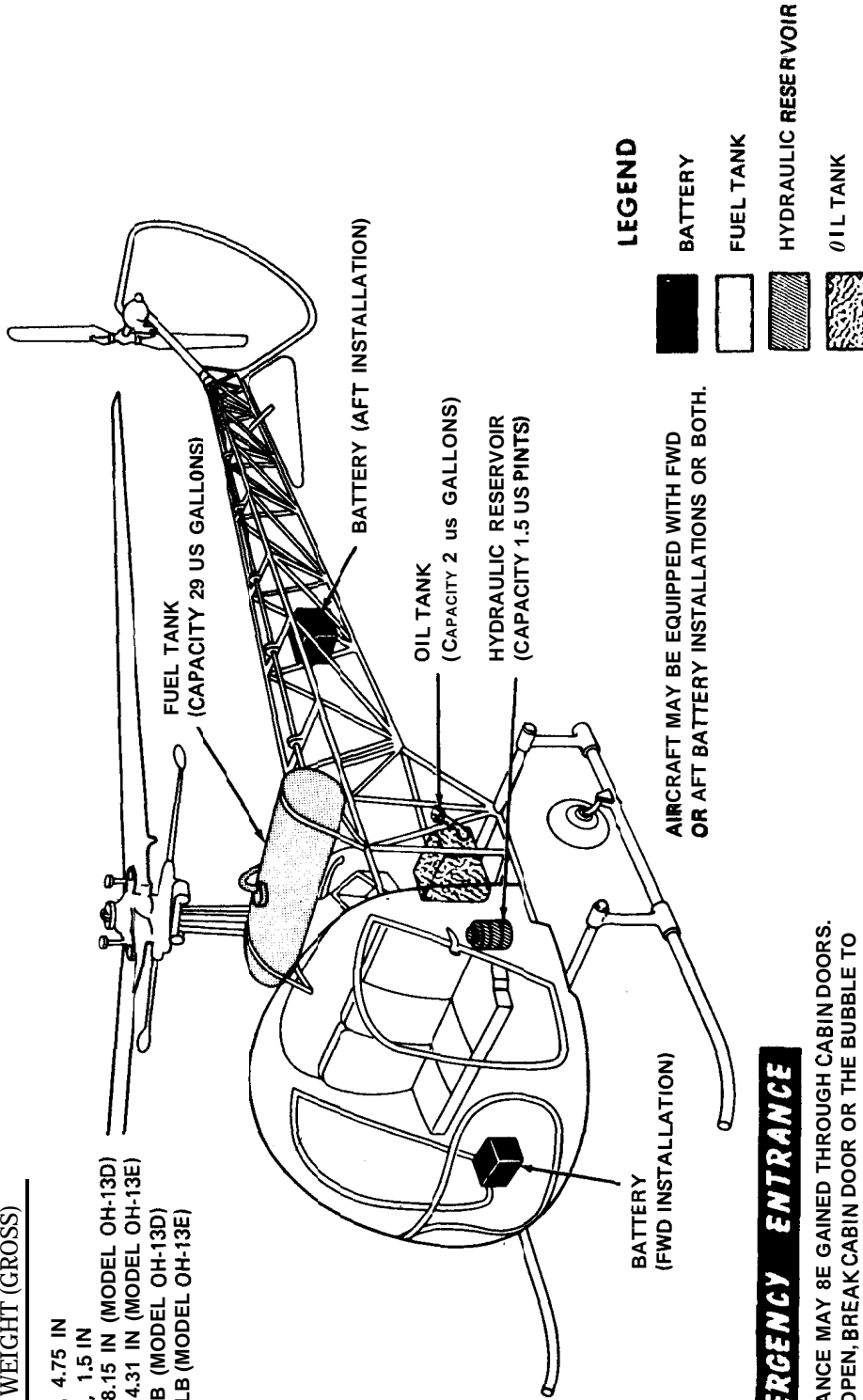

**EMERGENCY ENTRANCE**

EMERGENCY ENTRANCE MAY BE GAINED THROUGH CABIN DOORS. IF DOORS FAIL TO OPEN, BREAK CABIN DOOR OR THE BUBBLE TO GAIN ACCESS TO JETISON DOORS.

Figure 5-17. Model OH-13E aircraft.

GENERAL DESCRIPTION

TYPE - SINGLE ENGINE, HELICOPTER  
 CREW - 2  
 LITERS - 2

DIMENSIONS (MAX) AND WEIGHT (GROSS)

LENGTH - 41 FT, 4.75 IN  
 WIDTH - 35 FT, 1.5 IN  
 HEIGHT - 9 FT, 4.31 IN (MODEL OH-13G)  
 - 9 FT, 3.61 IN (MODEL OH-13H)  
 WEIGHT - 2350 LB

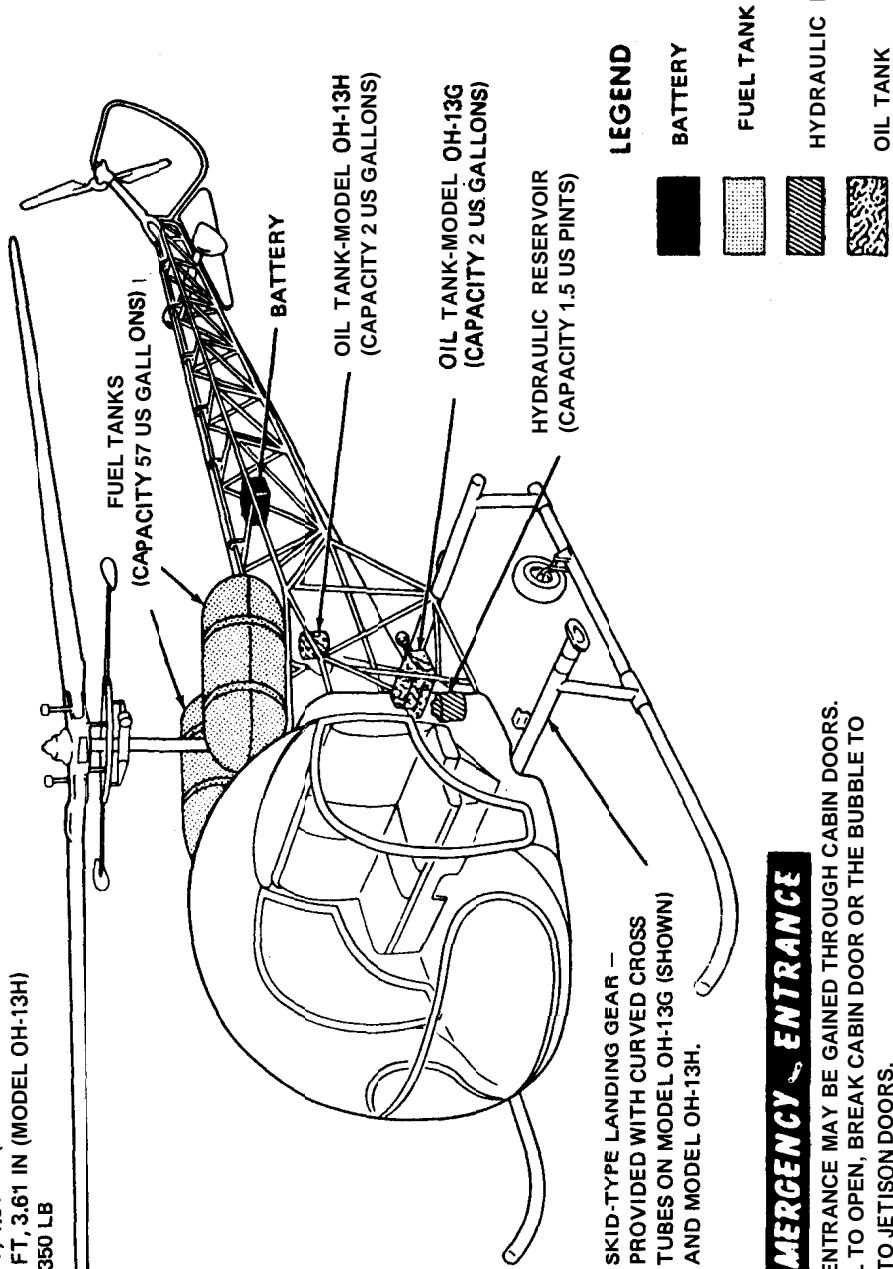

Figure 5-18. Models OH-13G, OH-13H, and OH-13K aircraft.

**GENERAL DESCRIPTION**

TYPE - SINGLE ENGINE, HELICOPTER  
 CREW - 2  
 PASSENGERS - NONE

**DIMENSIONS (MAX) AND WEIGHT (GROSS)**

LENGTH - 43 FT, 2.56 IN  
 WIDTH - 9 FT, 7 IN (OH-13S)  
 - 9 FT, 4 IN (TH-13T)  
 HEIGHT - 9 FT, 3.66 IN  
 WEIGHT - 1680 LB

NOTE: OH-13S and TH-13T ARE THE SAME HELICOPTERS, EXCEPT THAT THE TH-13T IS THE TRAINING MODEL WITH DUPLICATE CONTROLS.

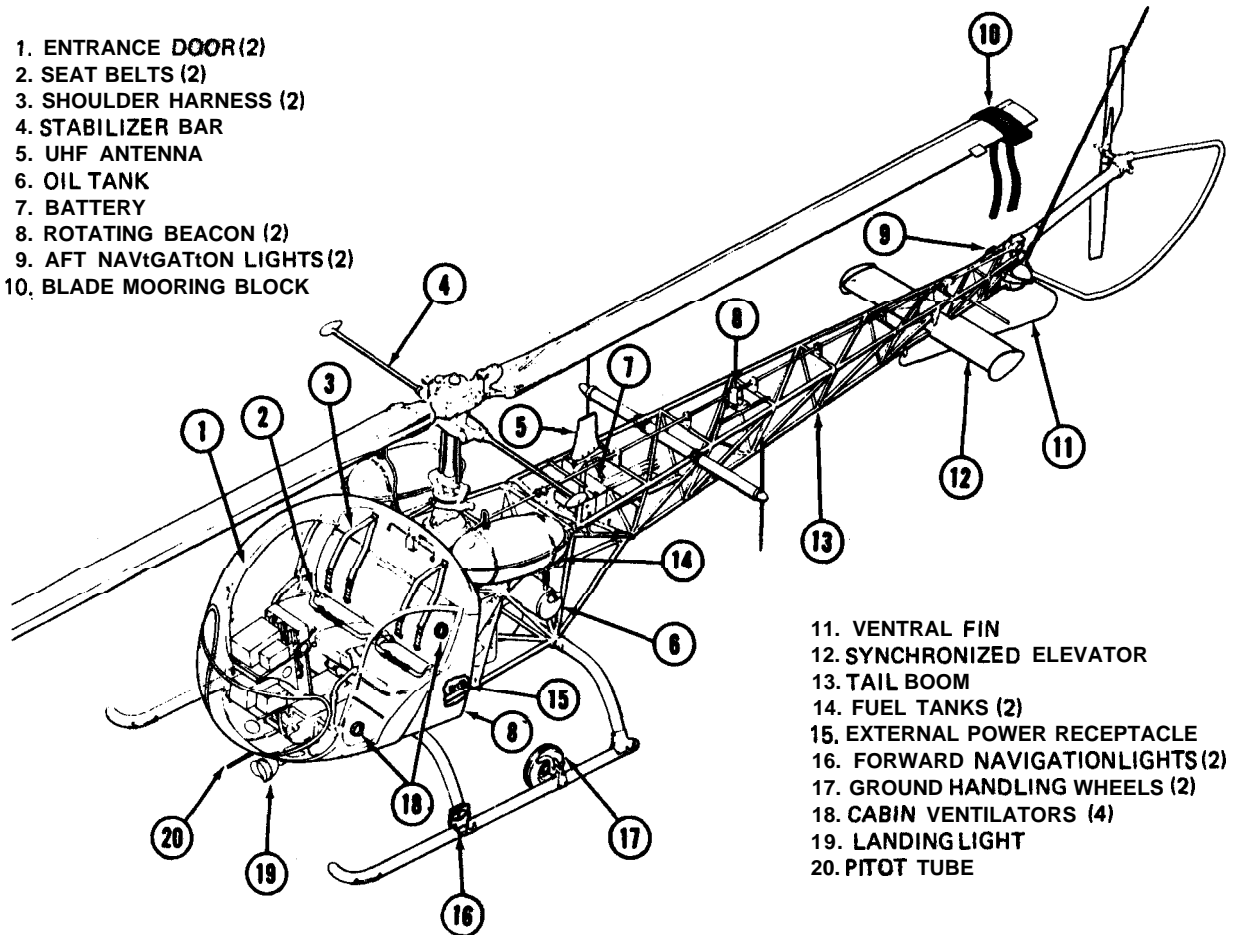

- 1. ENTRANCE DOOR (2)
- 2. SEAT BELTS (2)
- 3. SHOULDER HARNESS (2)
- 4. STABILIZER BAR
- 5. UHF ANTENNA
- 6. OIL TANK
- 7. BATTERY
- 8. ROTATING BEACON (2)
- 9. AFT NAVIGATION LIGHTS (2)
- 10. BLADE MOORING BLOCK

- 11. VENTRAL FIN
- 12. SYNCHRONIZED ELEVATOR
- 13. TAIL BOOM
- 14. FUEL TANKS (2)
- 15. EXTERNAL POWER RECEPTACLE
- 16. FORWARD NAVIGATION LIGHTS (2)
- 17. GROUND HANDLING WHEELS (2)
- 18. CABIN VENTILATORS (4)
- 19. LANDING LIGHT
- 20. PITOT TUBE

Figure 5-19. Models OH-13S and TH-13T aircraft.

## EMERGENCY PROCEDURES

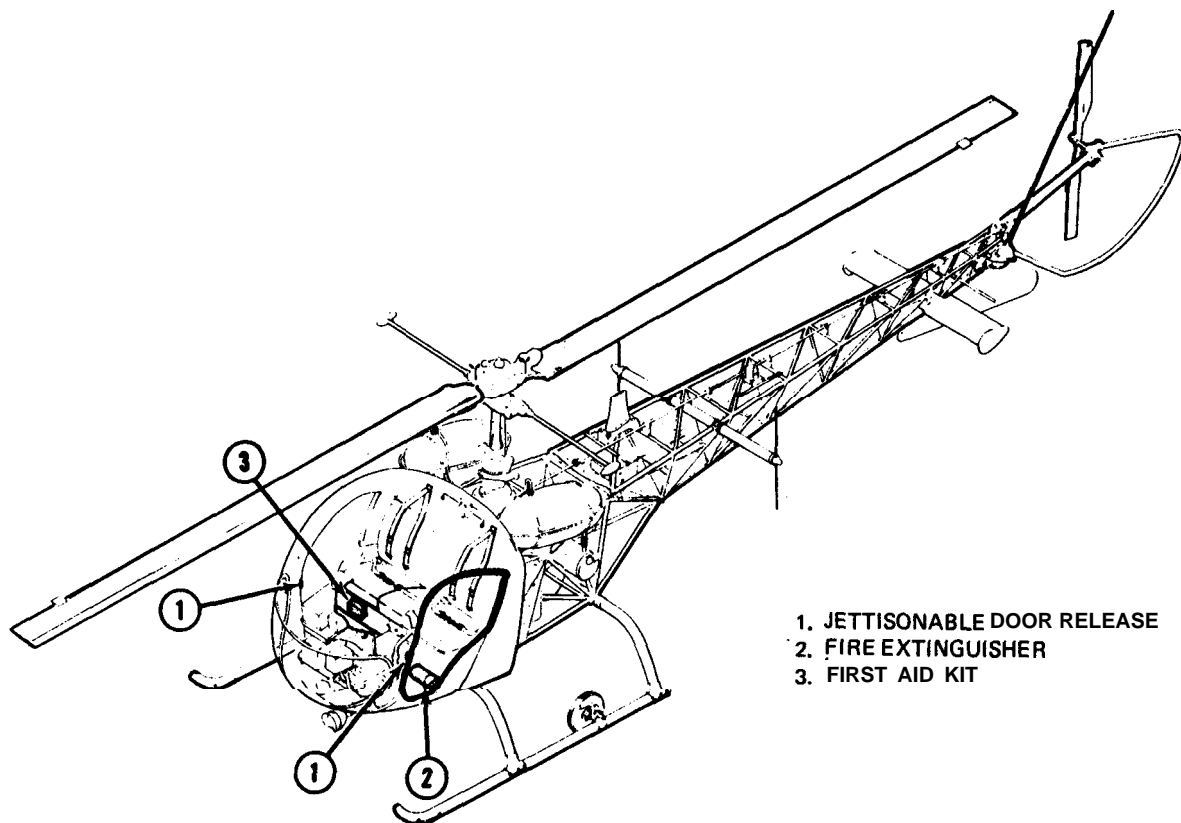

1. JETTISONABLE DOOR RELEASE
2. FIRE EXTINGUISHER
3. FIRST AID KIT

## EMERGENCY ENTRANCE

EMERGENCY ENTRANCE MAY BE GAINED THROUGH CABIN DOORS. IF DOORS FAIL TO OPEN, BREAK CABIN DOOR OR THE BUBBLE TO GAIN ACCESS TO JETTISON DOORS.

Figure 5-19. Models OH-13S and TH-13T aircraft—Continued.

GENERAL DESCRIPTION

- TYPE -- SINGLE ENGINE, HELICOPTER
- CREW -- 1 TO 3
- PASSENGERS -- 10 (LITERS -- 6)

DIMENSIONS (MAX) AND WEIGHT (GROSS)

- LENGTH -- 62 FT, 5.5 IN
- WIDTH -- 6.3 FT
- HEIGHT -- 14 FT, 6.6 IN
- WEIGHT -- 7500 LB

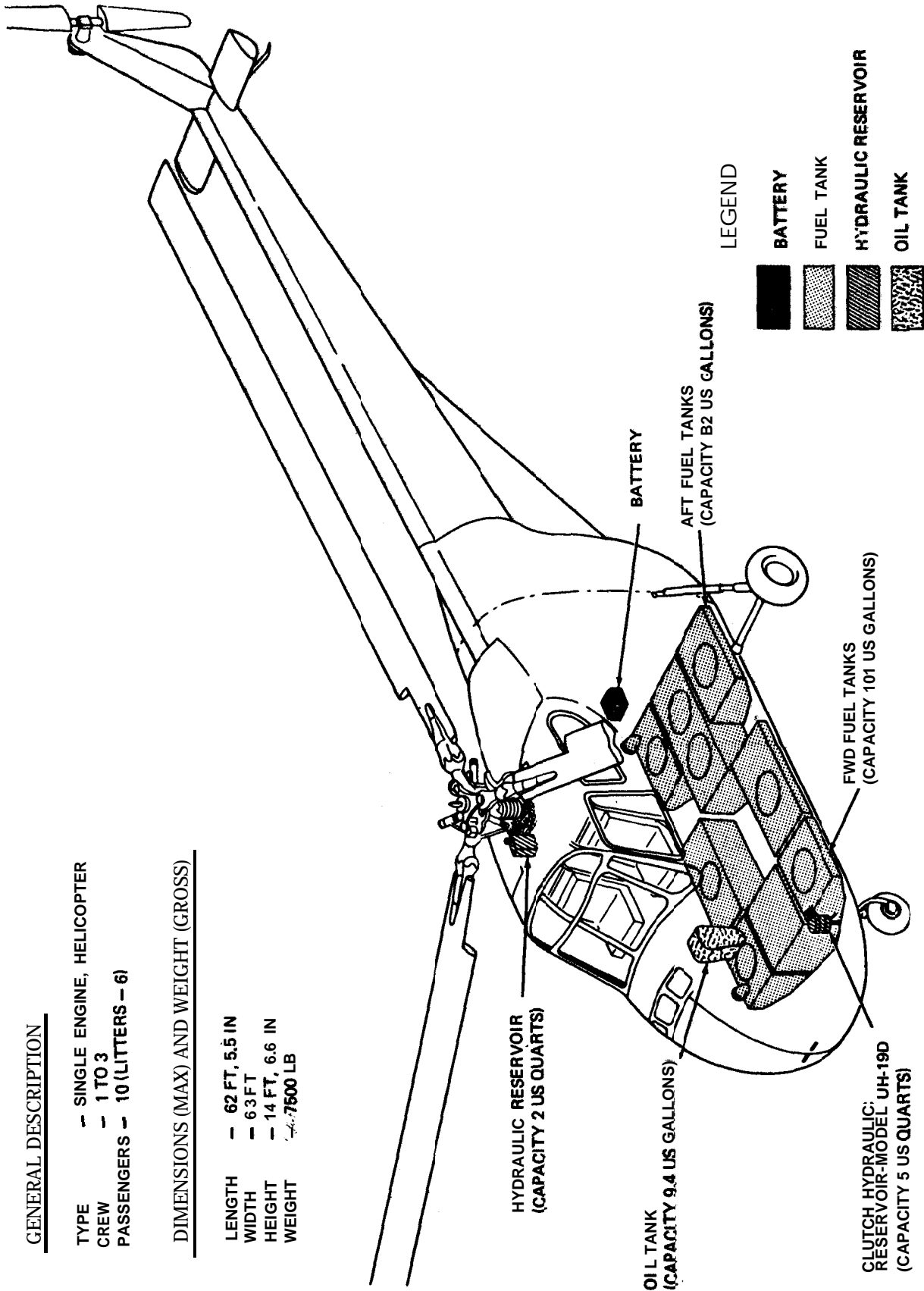
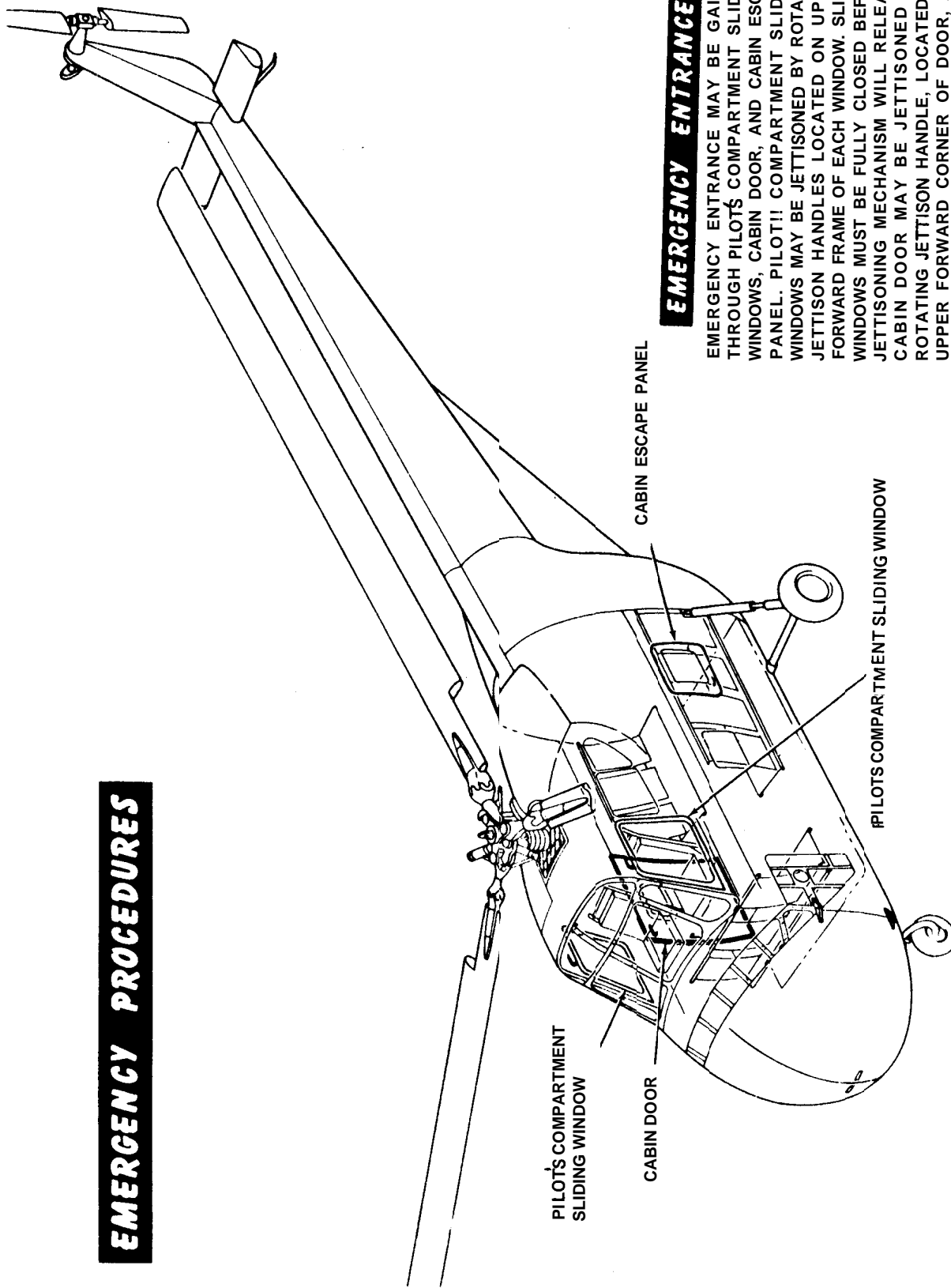

Figure 5-20. Models UH-19C and UH-19D aircraft.

# EMERGENCY PROCEDURES



## EMERGENCY ENTRANCE

EMERGENCY ENTRANCE MAY BE GAINED THROUGH PILOTS COMPARTMENT SLIDING WINDOWS, CABIN DOOR, AND CABIN ESCAPE PANEL. PILOT!! COMPARTMENT SLIDING WINDOWS MAY BE JETTISONED BY ROTATING JETTISON HANDLES LOCATED ON UPPER FORWARD FRAME OF EACH WINDOW. SLIDING WINDOWS MUST BE FULLY CLOSED BEFORE JETTISONING MECHANISM WILL RELEASE. CABIN DOOR MAY BE JETTISONED BY ROTATING JETTISON HANDLE, LOCATED ON UPPER FORWARD CORNER OF DOOR, AND PULLING OUTWARD ON DOOR. CABIN ESCAPE PANEL MAY BE JETTISONED BY ROTATING JETTISON HANDLE AND PULLING OUTWARD.

Figure 5-20. Models UH-19C and UH-19D aircraft—Continued.

GENERAL DESCRIPTION

TYPE -- SINGLE ENGINE, HELICOPTER  
 CREW -- 1 T 0 5  
 PASSENGERS -- 20 (LITTERS-12)

DIMENSIONS (MAX) AND WEIGHT (GROSS)

LENGTH -- 86 FT, 4 IN  
 WIDTH -- 44 FT  
 HEIGHT -- 15 FT, 4 IN  
 WEIGHT -- 13,500 LB

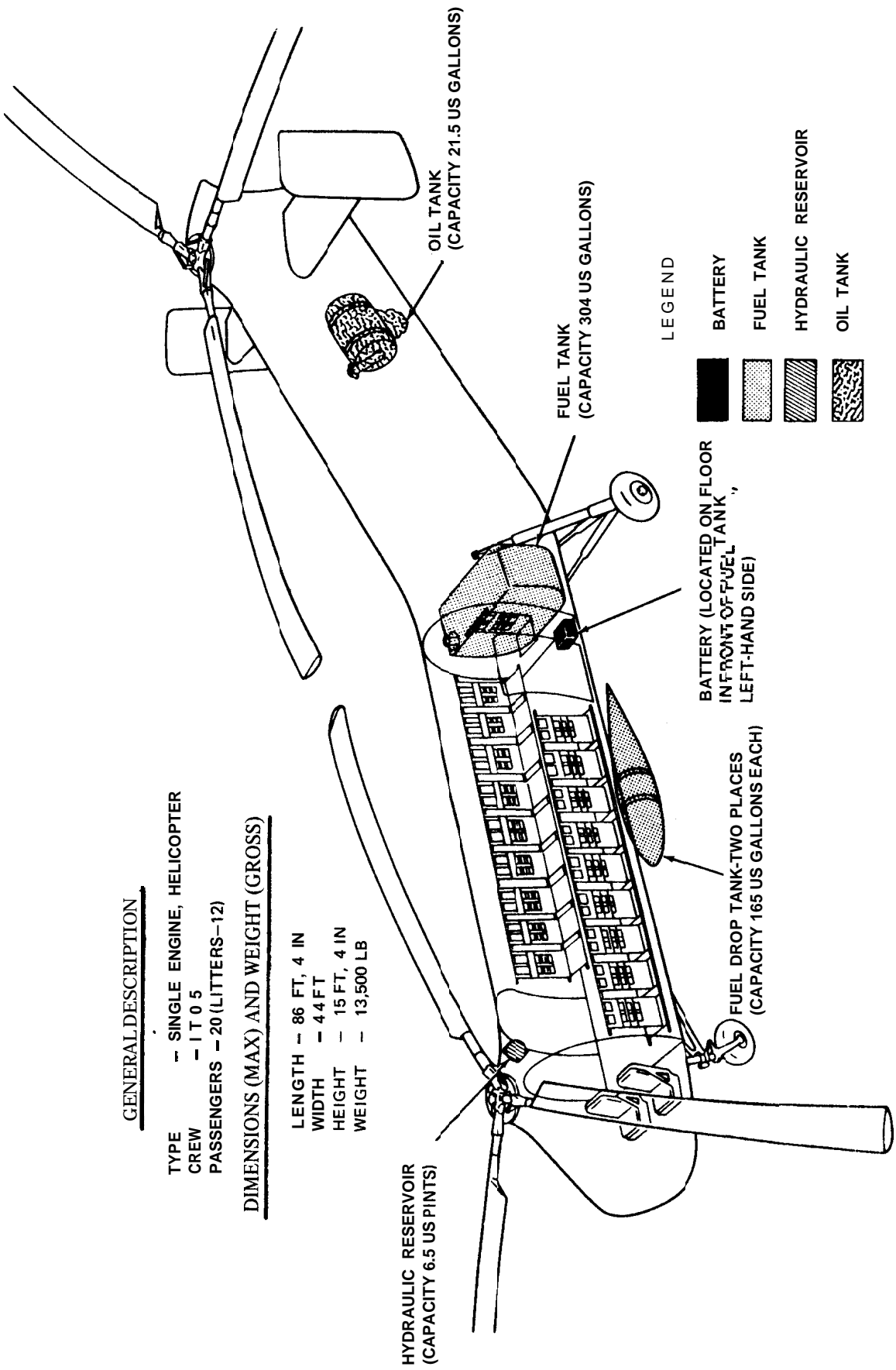
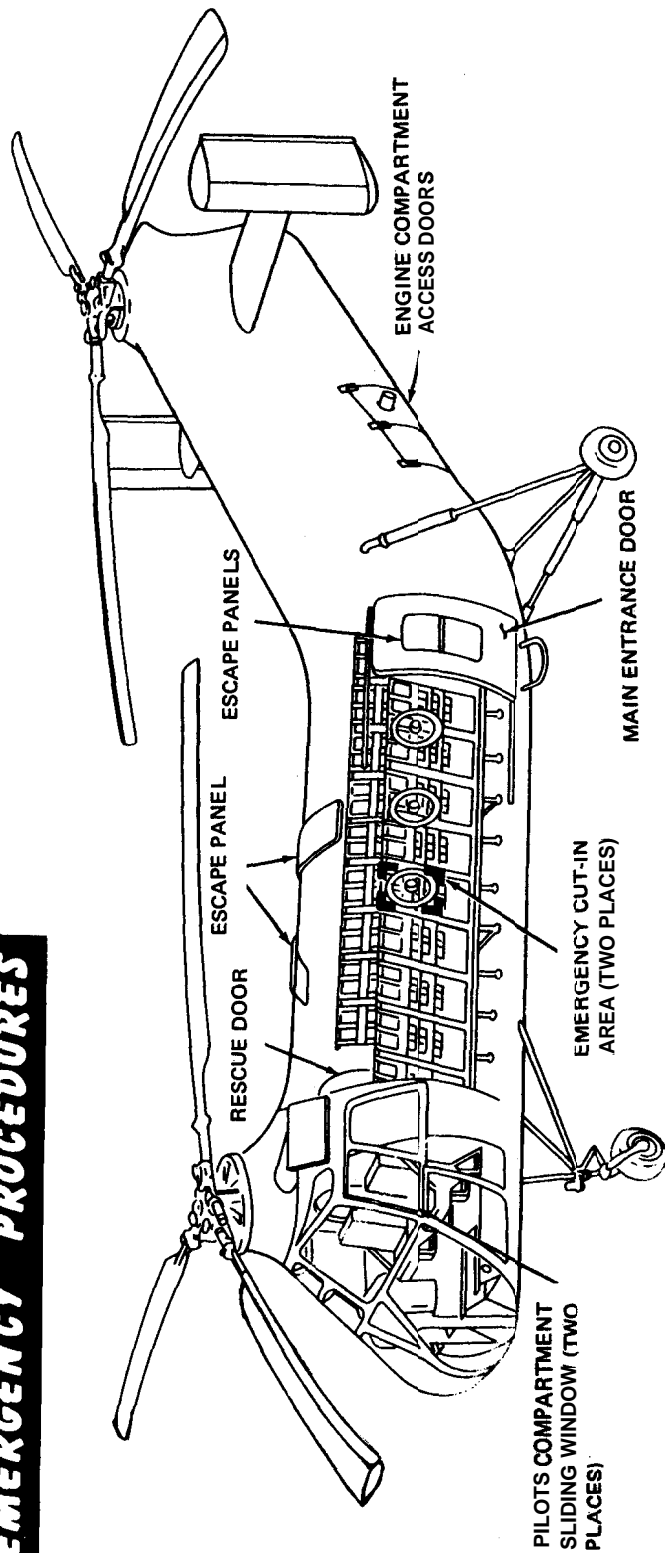

Figure 5-21. Models CH-21 B and CH-21C aircraft.



# EMERGENCY PROCEDURES



## EMERGENCY ENTRANCE

EMERGENCY ENTRANCE MAY BE MADE THROUGH OVERHEAD ESCAPE PANELS, MAIN ENTRANCE DOOR ESCAPE PANEL, RESCUE DOOR ESCAPE PANEL, AND PILOTS SLIDING WINDOWS. TO OPEN OVERHEAD ESCAPE PANELS, RESCUE, AND MAIN ENTRANCE DOOR ESCAPE PANELS, PULL RED PROTRUDING TAB FROM PANEL. JETTISON PILOTS SLIDING WINDOWS BY PULLING OUT ON EXTERNAL JETTISON HANDLE. PILOTS SLIDING WINDOWS, RESCUE DOOR (LOCATED ON RIGHT-HAND SIDE OF FUSELAGE), AND MAIN ENTRANCE DOOR ARE PROVIDED WITH INTERNAL JETTISON HANDLES.

Figure 5-21. Models CH-21B and CH-21C aircraft—Continued.

**GENERAL DESCRIPTION**

TYPE - SINGLE ENGINE, HELICOPTER  
 CREW - 1  
 PASSENGERS - 2 (LITTERS-2)

**DIMENSIONS (MAX) AND WEIGHT (GROSS)**

LENGTH - 40 FT, 6 IN  
 WIDTH - 10 FT  
 HEIGHT - 9 FT, 7.2 IN  
 WEIGHT - 2500 LB

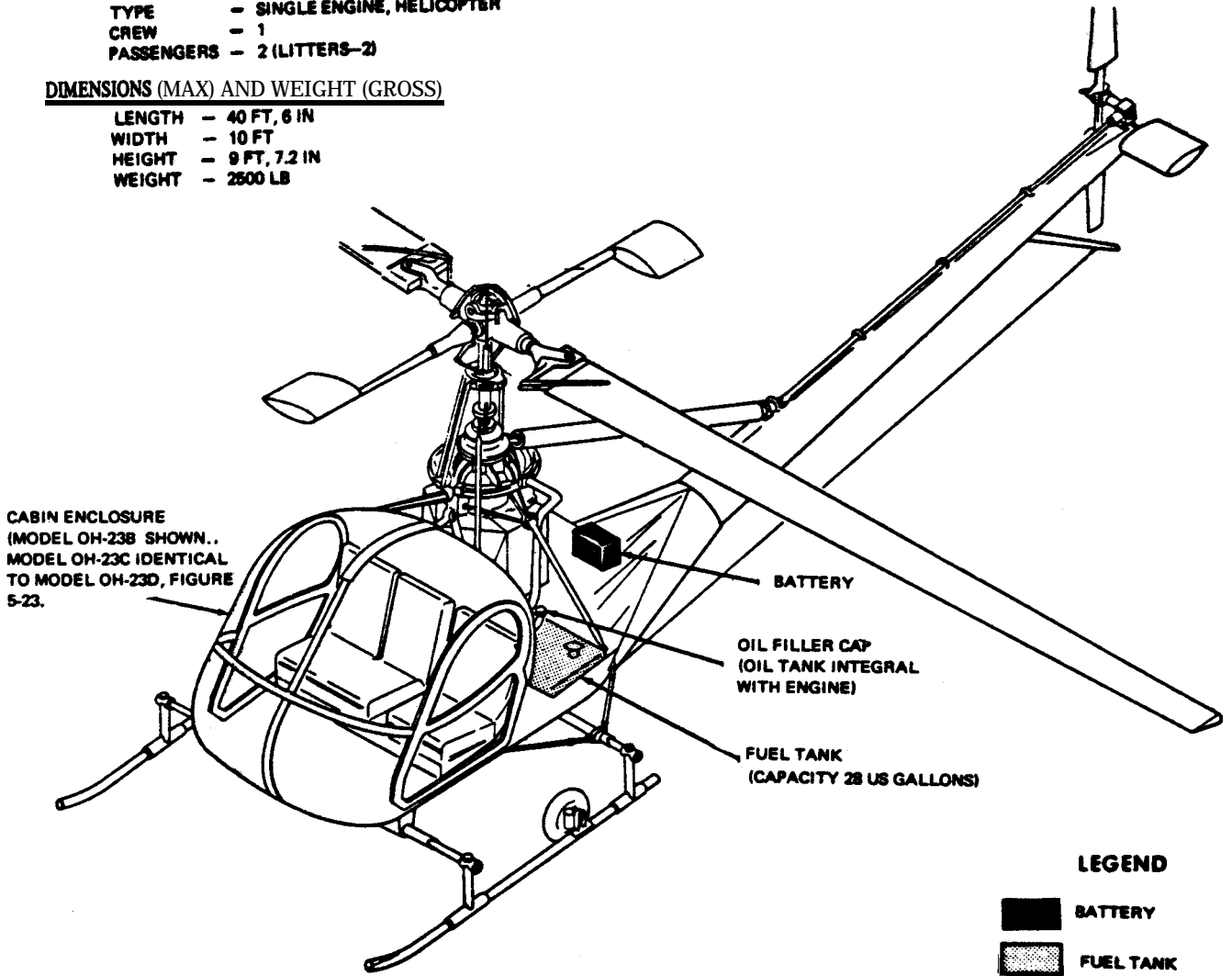
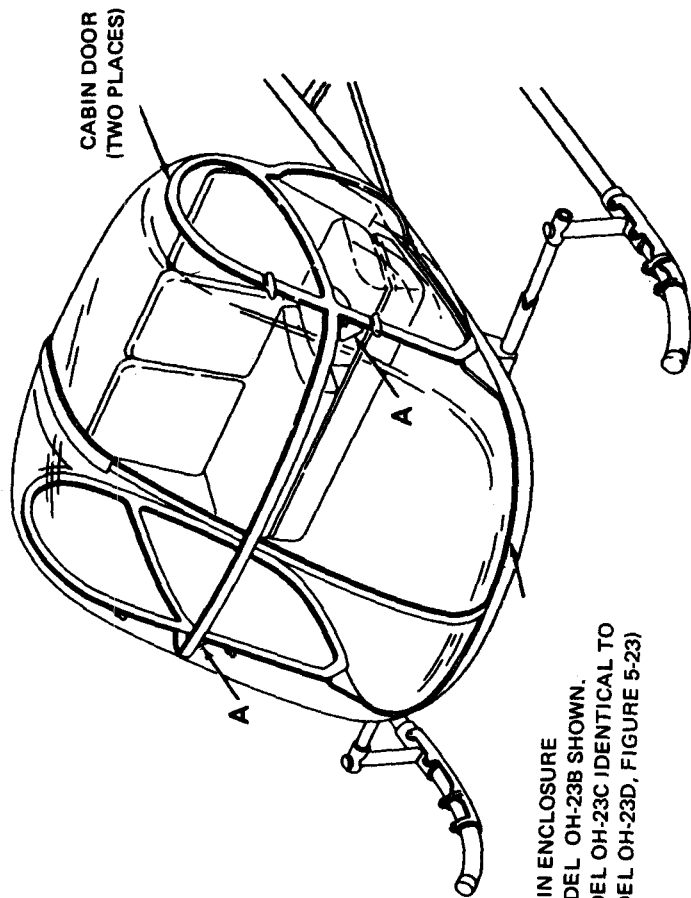

Figure 5-22. Models OH-23B and OH-23C aircraft.



CABIN DOOR  
(TWO PLACES)

CABIN ENCLOSURE  
(MODEL OH-23B SHOWN.  
MODEL OH-23C IDENTICAL TO  
MODEL OH-23D, FIGURE 5-23)

**EMERGENCY ENTRANCE**

EMERGENCY ENTRANCE IS GAINED THROUGH CABIN DOORS. IF DOORS FAIL TO OPEN, BREAK WINDOWS TO GAIN ACCESS TO DOOR JETTISON HANDLE. DOOR IS JETTISONED BY PULLING HANDLE. (SEE DETAIL A.)

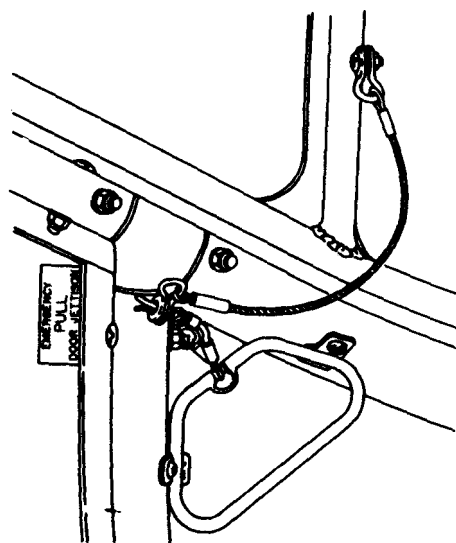

**DETAIL A**  
DOOR JETTISON HANDLE

Figure 5-22. Models OH-23B and OH-23C aircraft—Continued.

GENERAL DESCRIPTION

TYPE - SINGLE ENGINE, HELICOPTER  
 CREW - 1  
 PASSENGERS - 2 (LITTERS-2)

DIMENSIONS (MAX) AND WEIGHT (GROSS)

LENGTH - 40 FT, 8.5 IN  
 WIDTH - 10 FT  
 HEIGHT - 10 FT, 1.5 IN  
 WEIGHT - 2700 LB

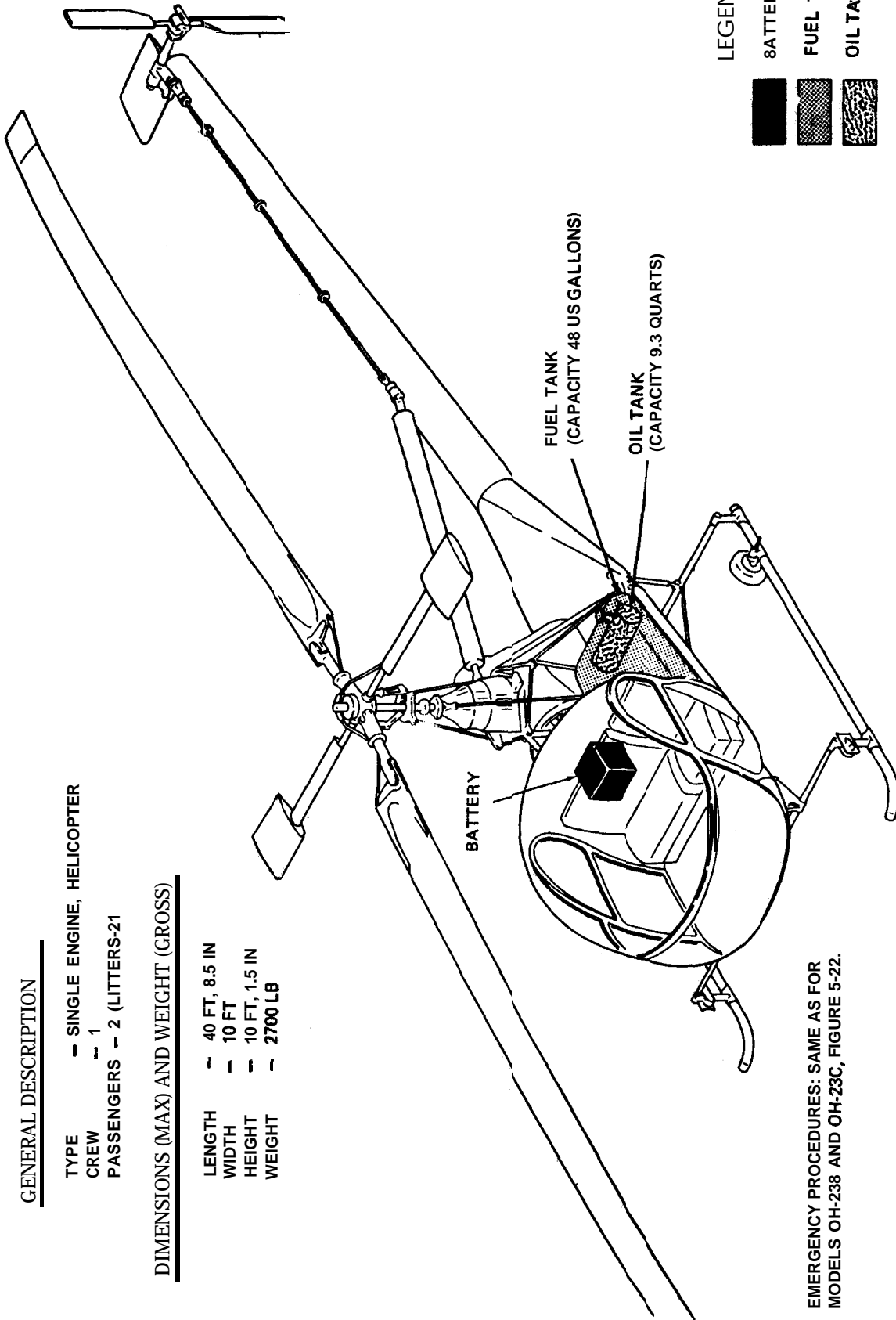

EMERGENCY PROCEDURES: SAME AS FOR  
 MODELS OH-238 AND OH-23C, FIGURE 5-22.

Figure 5-23. Models OH-23D and OH-28G aircraft.

GENERAL DESCRIPTION

TYPE - SINGLE ENGINE, HELICOPTER  
 CREW - 1  
 PASSENGERS - 2

DIMENSIONS (MAX) AND WEIGHT (GROSS)

LENGTH - 40 FT, 8 1/2 IN  
 WIDTH - 7 FT, 9 1/2 IN  
 HEIGHT - 10 FT, 1 1/2 IN  
 WEIGHT - 1710 LB

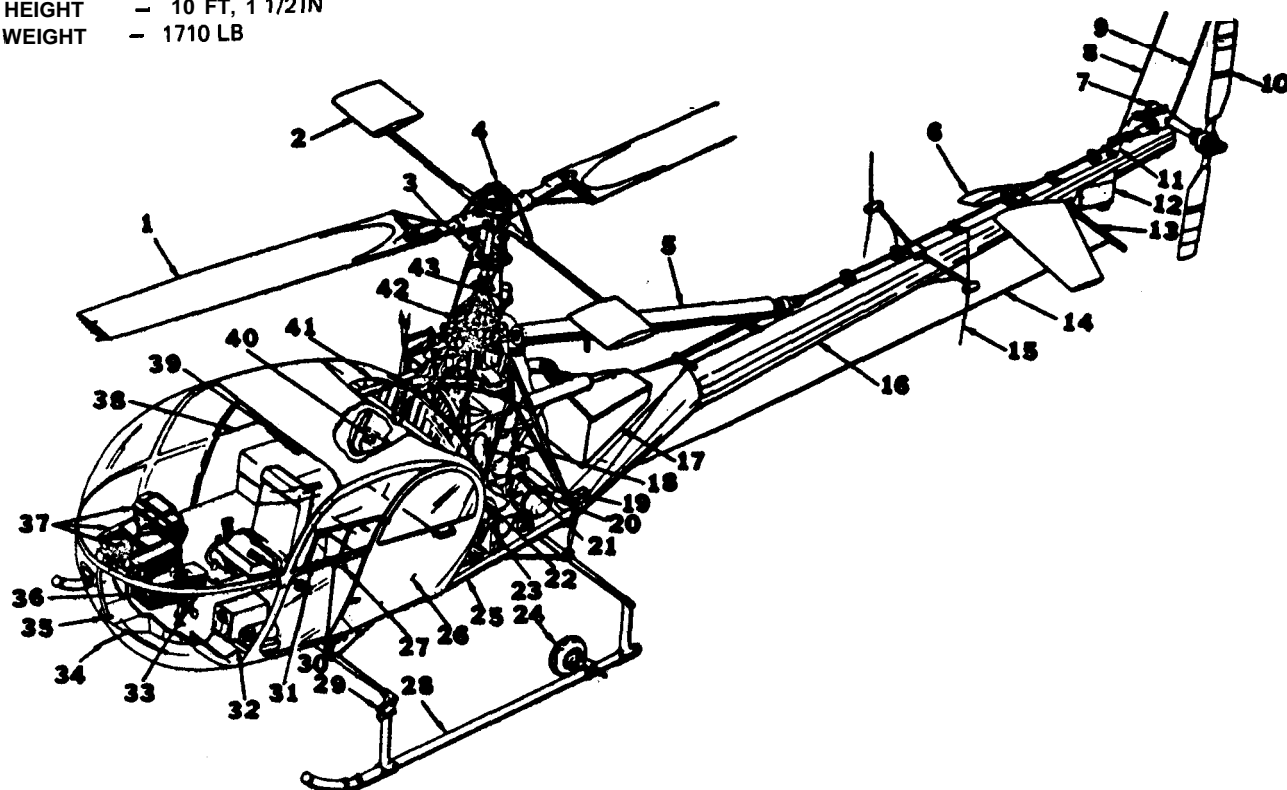

- |   |                               |
|---|-------------------------------|
| 1. MAIN ROTOR                           | 23. OIL COOLER (ENGINE)       |
| 2. CONTROL ROTOR                        | 24. GROUND HANDLING WHEELS    |
| 3. WOBBLE PLATE                         | 25. BASIC BODY SECTION        |
| 4. COLLECTIVE BALLAST                   | 26. LH CABIN DOOR             |
| 5. TAIL ROTOR DRIVE                     | 27. UTILITY POWER RECEPTACLE  |
| 6. STABILIZER                           | 28. SKID LANDING GEAR         |
| 7. TAIL ROTOR SPEED DECREASER GEAR ASSY | 29. NAVIGATION LIGHT          |
| 8. ANTENNA                              | 30. WINDOW PANEL              |
| 9. ANTENNA                              | 31. VENTILATOR WING           |
| 10. TAIL ROTOR                          | 32. RADIO EQUIPMENT           |
| 11. TAIL ROTOR CDNTROL CABLES           | 33. PEDESTAL TUNNEL           |
| 12. BATTERY                             | 34. PITOT TUBE                |
| 13. TAIL SKID STRUT                     | 35. LANDING LIGHT             |
| 14. ANTENNA                             | 36. INSTRUMENT PEDESTAL       |
| 15. ANTENNA                             | 37. RADIO EQUIPMENT           |
| 16. TAIL 800M                           | 38. RH CABIN DOOR             |
| 17. CARGO COMPARTMENT                   | 39. CABIN HEAT DIFFUSER       |
| 18. ENGINE                              | 40. EXTERNAL POWER RECEPTACLE |
| 19. FUEL TANK FILLER                    | 41. FIREWALL                  |
| 20. OIL TANK FILLER CAP (TRANSMISSION)  | 42. TRANSMISSION              |
| 21. OIL TANK FILLER CAP (ENGINE)        | 43. ANTICOLLISION LIGHT       |
| 22. OIL COOLER (TRANSMISSION)           |                               |

**EMERGENCY - ENTRANCE**

EMERGENCY PROCEDURES SAME AS FOR MODEL OH-23D, FIGURE 5-23, EXCEPT THAT BATTERY IS IN TAIL.

Figure 5-24. Model OH-23F aircraft.

**GENERAL DESCRIPTION**

TYPE - SINGLE ENGINE, HELICOPTER  
 CREW - 2  
 PASSENGERS - 12 TO 18 (LITTERS-8)

**DIMENSIONS (MAX) AND WEIGHT (GROSS)**

LENGTH - 65 FT, 10 IN  
 WIDTH - 56 FT  
 HEIGHT - 15 FT, 11 IN  
 WEIGHT - 13,600 LB

PRIMARY SERVO HYDRAULIC RESERVOIR  
 (CAPACITY 2.5 US QUARTS)

AUXILIARY SERVO HYDRAULIC RESERVOIR -  
 LATE MODEL CH-34A AND ALL CH-34C  
 (CAPACITY 2.5 US QUARTS).

BATTERY (ACCESSIBLE THROUGH  
 FLOOR UNDER COPILOT'S SEAT)





AUXILIARY SERVO HYDRAULIC  
 RESERVOIR-EARLY MODEL CH-34A  
 (CAPACITY 2.5 US QUARTS)

ENGINE OIL TANKS-INTERCONNECTED  
 (CAPACITY 10.5 US GALLONS)

ROTOR BRAKE HYDRAULIC CYLINDER  
 AFT FUEL TANKS  
 (CAPACITY 92 US GALLONS)  
 (CENTER FUEL TANKS  
 (CAPACITY 70 US GALLONS))

FWD FUEL TANKS  
 (CAPACITY 101 US GALLONS)

**LEGEND**

	BATTERY
	FUEL TANK
	HYDRAULIC RESERVOIR
	OIL TANK

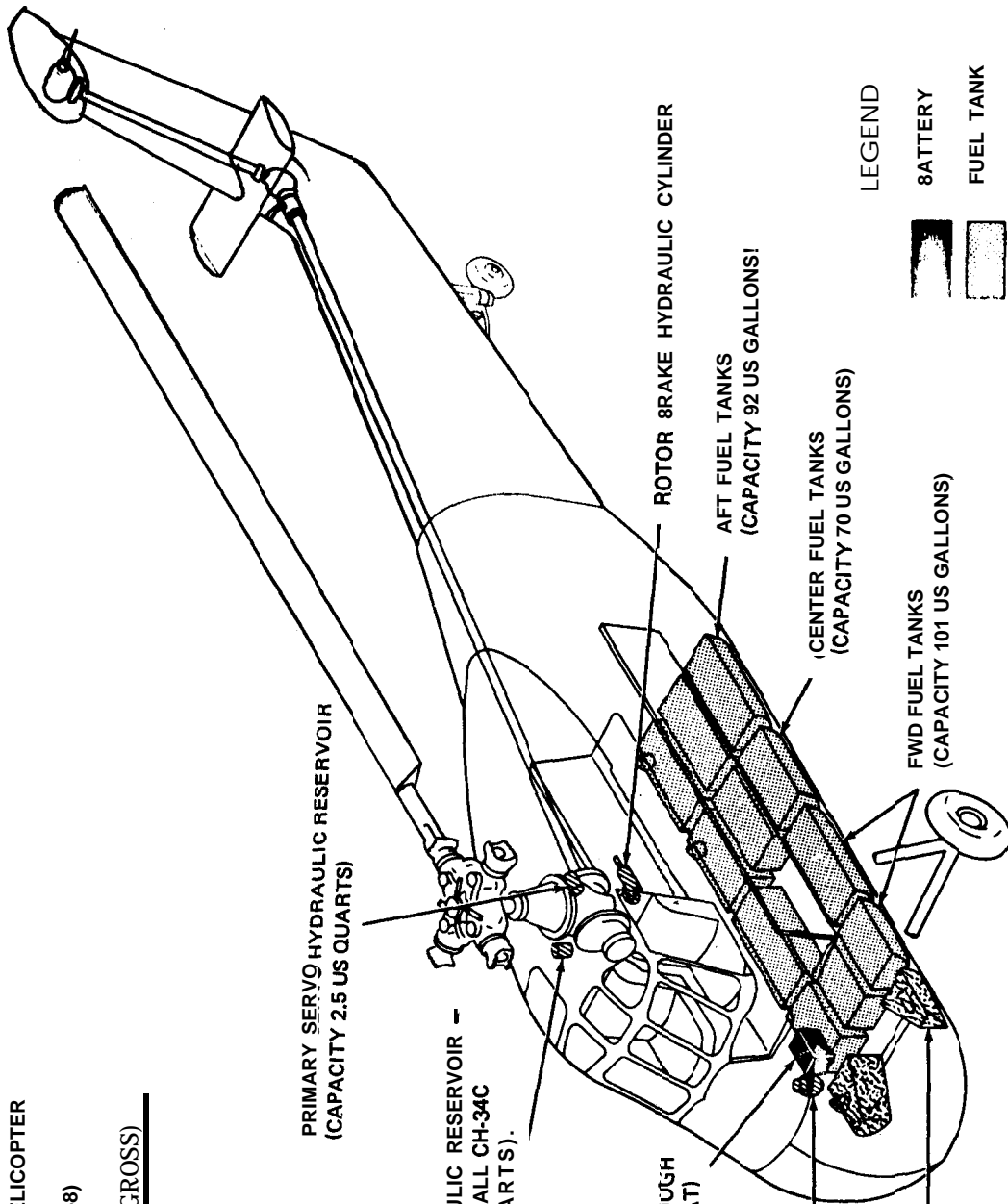
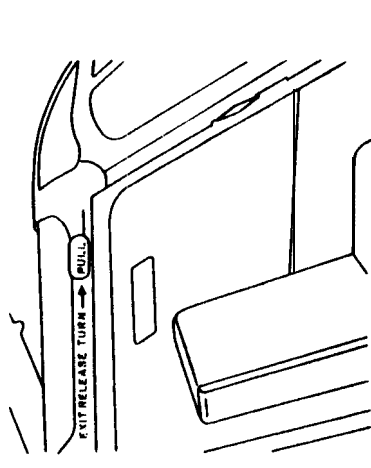
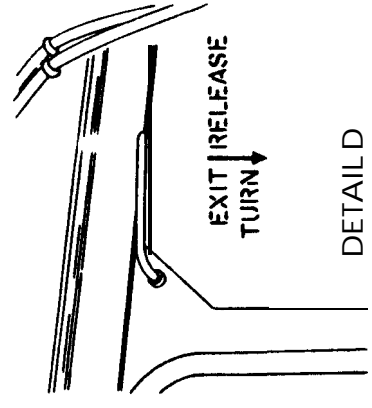

Figure 5-25. Models CH-34A and CH-34C aircraft.

# EMERGENCY PROCEDURES



DETAIL B  
OUTSIDE PILOTS COMPARTMENT  
WINDOW RELEASE HANDLE (TWO PLACES)



DETAIL D  
OUTSIDE CABIN DOOR EMERGENCY  
RELEASE HANDLE

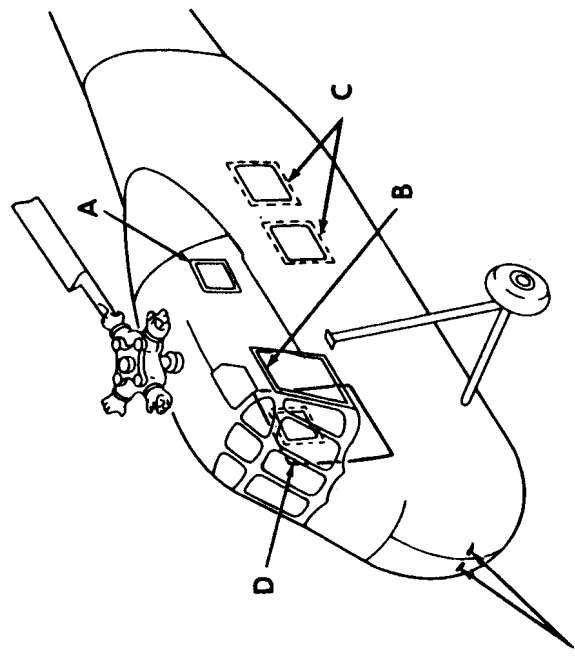

ENGINE ACCESS DOOR HANDLES

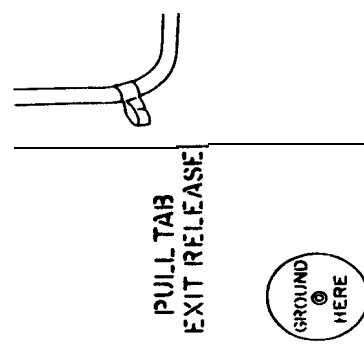

DETAIL A  
OUTSIDE CABIN EMERGENCY  
ESCAPE WINDOW TAB

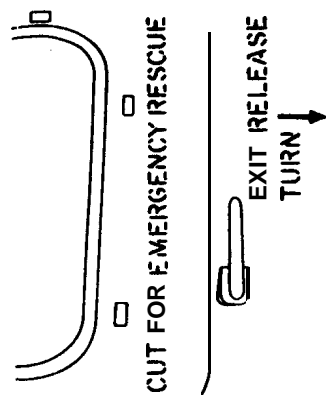

DETAIL C  
OUTSIDE CABIN EMERGENCY ESCAPE  
HATCH RELEASE HANDLES

## EMERGENCY ENTRANCE

EMERGENCY ENTRANCE IS GAINED THROUGH CABIN DOOR, PILOTS COMPARTMENT WINDOWS, ESCAPE HATCHES, AND ESCAPE WINDOW. BROKEN YELLOW LINES SURROUNDING CABIN DOOR WINDOW, AND ESCAPE HATCHES INDICATE WHERE FUSELAGE MAY BE CUT IF DOOR OR ESCAPE HATCHES FAIL TO OPEN.

Figure 5-25. Models CH-34A and CH-34C aircraft—Continued.

GENERAL DESCRIPTION

- TYPE - TWIN ENGINE, HELICOPTER
- CREW - 2 OR 3
- PASSENGERS - 23 (LITTERS-241)

DIMENSIONS (MAX) AND WEIGHT (GROSS)

- LENGTH - 88 FT, 2.85 IN
- WIDTH - 68 FT, 5.75 IN
- HEIGHT - 21 FT, 9 IN
- WEIGHT - 31,000 LB

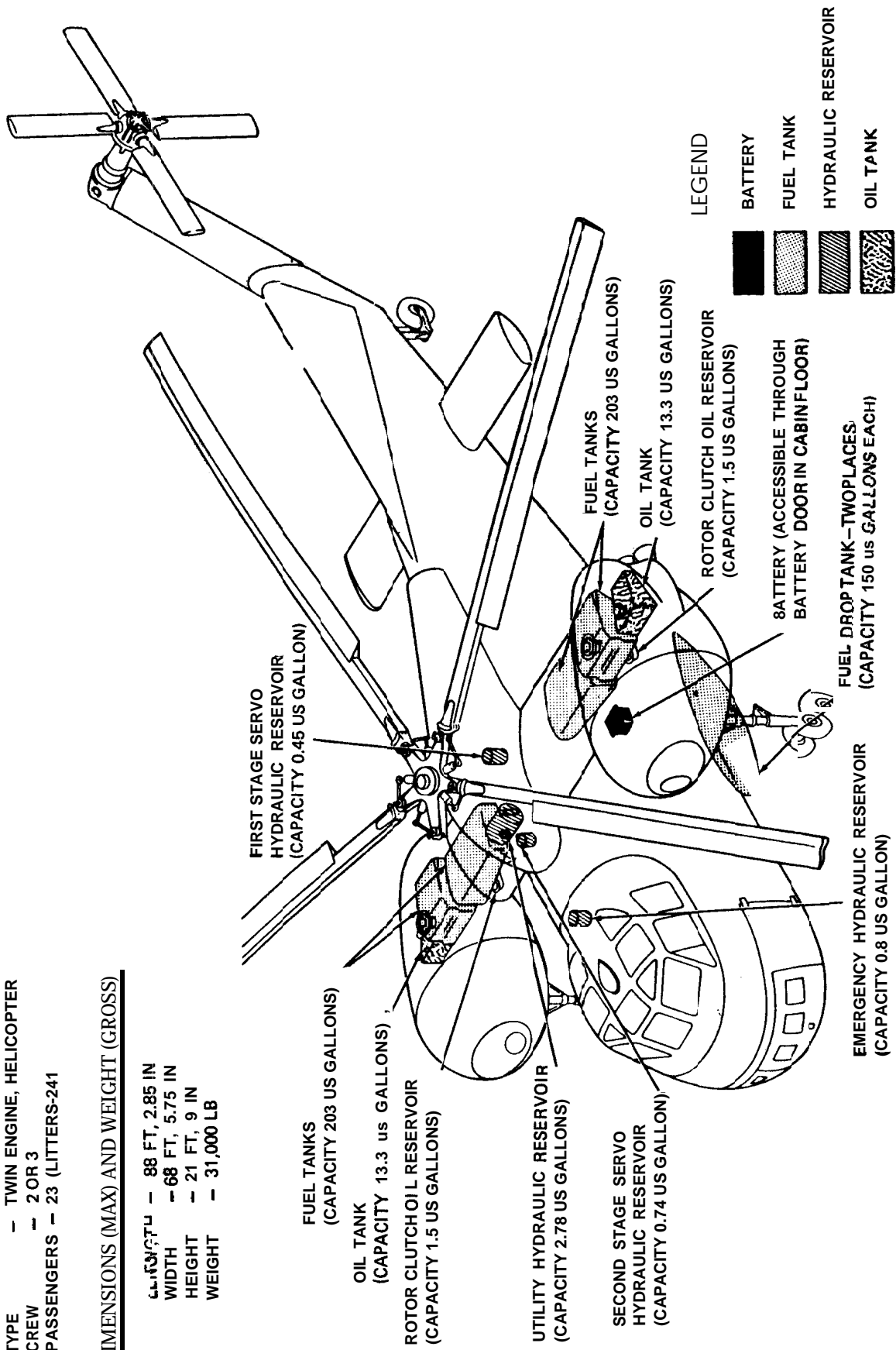
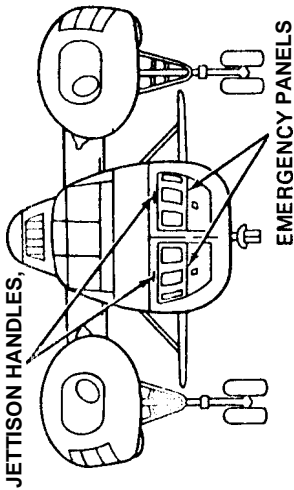

Figure 5-26. Model CH-37B aircraft.



# EMERGENCY PROCEDURES



DETAIL C  
NOSE DOORS

## EMERGENCY ENTRANCE

EMERGENCY ENTRANCE IS NORMALLY GAINED THROUGH UPPER AND LOWER PASSENGER DOORS (DETAIL A), LOCATED ON RIGHT-HAND SIDE OF CABIN, BY TURNING DOOR HANDLES. UPPER PASSENGER DOOR MAY BE JETTISONED BY TURNING JETTISON HANDLES, MARKED TURN EXIT RELEASE. EMERGENCY ENTRANCES MAY ALSO BE GAINED THROUGH CABIN EMERGENCY HATCH, NOSE DOOR EMERGENCY PANELS, PILOT'S COMPARTMENT WINDOWS, AND FOUR FORWARD CABIN WINDOWS. CABIN EMERGENCY HATCH (DETAIL B) MAY BE JETTISONED BY TURNING JETTISON HANDLE MARKED TURN EXIT RELEASE. HATCH WINDOW PANE MAY BE REMOVED BY PULLING TAB, MARKED PULL TAB EXIT RELEASE. NOSE DOOR EMERGENCY PANELS (DETAIL C) MAY BE JETTISONED BY PULLING JETTISON HANDLE, MARKED RELEASE PULL TO JETTISON. PILOT: COMPARTMENT EMERGENCY PANELS MAY BE JETTISONED BY PULLING DOWN ON JETTISON HANDLE, MARKED PULL DOWN EXIT RELEASE. EACH OF FOUR FORWARD CABIN WINDOW PANES ARE PROVIDED WITH A PULL TAB, MARKED PULL TAB EXIT RELEASE. BROKEN YELLOW LINES SURROUNDING CABIN WINDOWS INDICATE EMERGENCY CUT-IN AREAS.

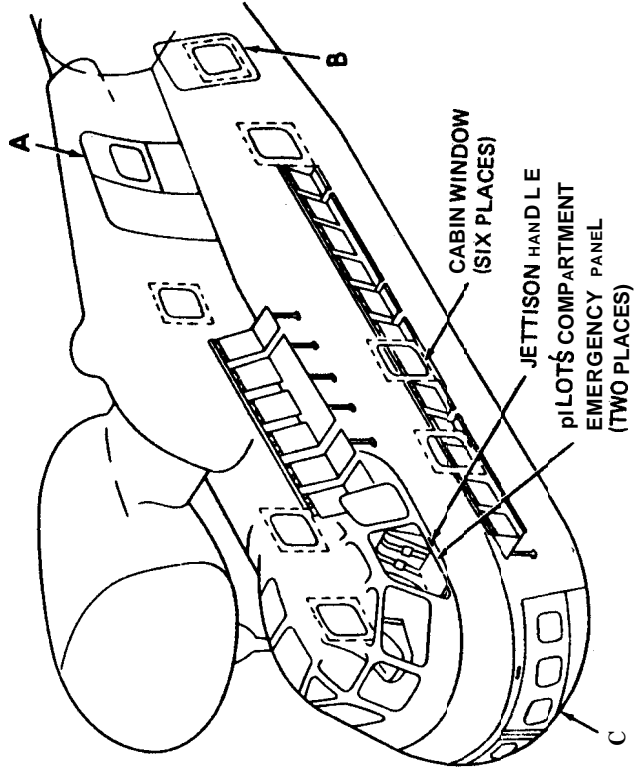
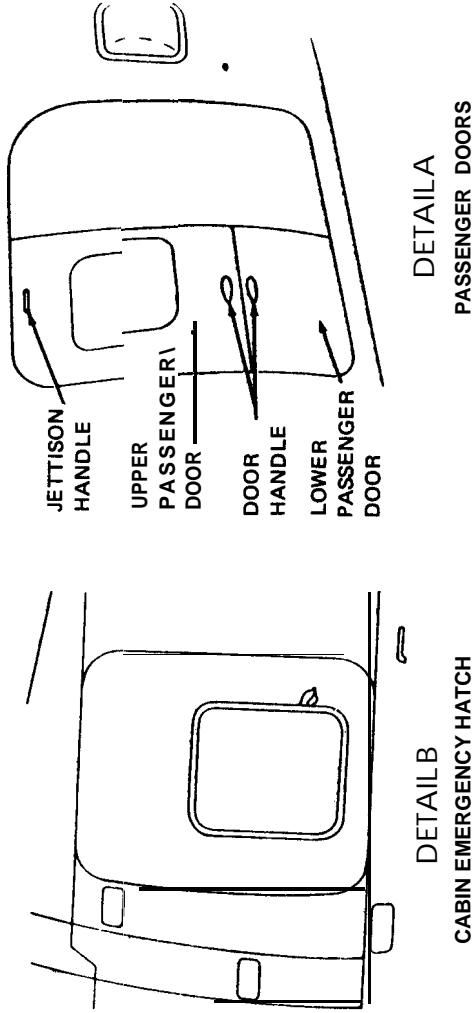

Figure 5-26. Model CH-37B aircraft—Continued.

GENERAL DESCRIPTION

TYPE - TWIN ENGINE, HELICOPTER  
 CREW - 2  
 PASSENGERS - 33 (LITTERS-241)

DIMENSIONS (MAX) AND WEIGHT (GROSS)

LENGTH - 98 FT, 13/10 IN  
 WIDTH - 12 FT, 5 IN  
 HEIGHT - 18 FT, 6 2/5 IN  
 WEIGHT - 24,500 LB

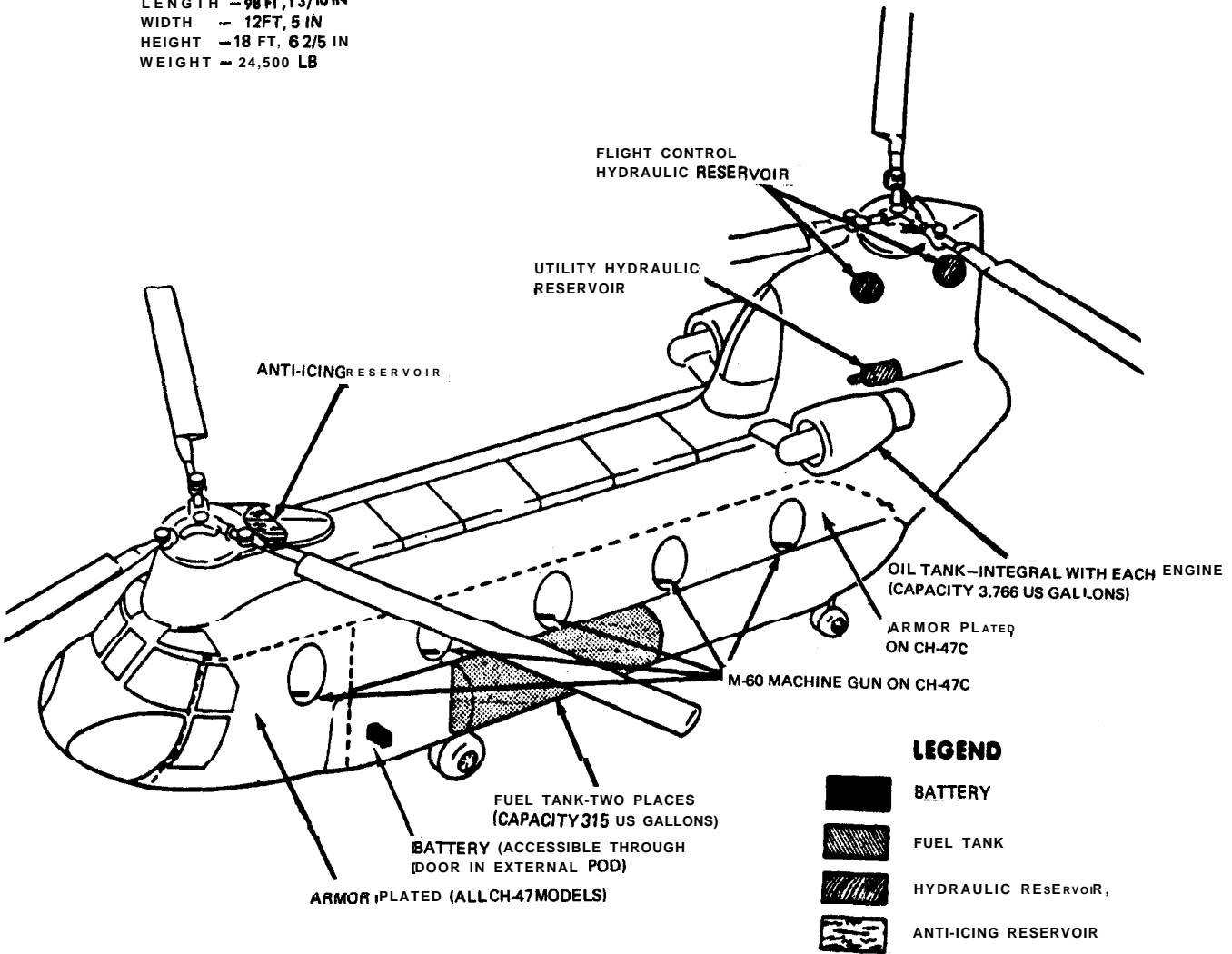

**EMERGENCY ENTRANCE**

EMERGENCY ENTRANCE IS GAINED THROUGH DOORS. IF DOOR FAILS TO OPEN, BREAK GLASS TO GAIN ACCESS TO DOOR JETTISON HANDLE.

Figure 5-27. Models CH-47A, CH-47B, and CH-47C aircraft.

GENERAL DESCRIPTION

- TYPE - FREE TURBINE ENGINE, HELICOPTER
- CREW - 2 (3 ADDITIONAL SEATS)
- USE - TRANSPORTATION OF EQUIPMENT, CARGO (15,541 LB), AND AIR-TO-SURFACE TOWING

DIMENSIONS (MAX) AND WEIGHT (GROSS)

- LENGTH - 85 FT, 5 IN (ROTOR BLADES ROTATING-88 FT, 6 IN)
- WIDTH - COCKPIT-7 FT, 1 IN; FUSELAGE-6 FT, 8 IN; MAIN ROTOR BLADES-72 FT
- HEIGHT - TOP OF TAIL ROTOR-25 FT, 7.4 IN; TOP OF ROTOR-18 FT, 7 IN
- WEIGHT - 38,000 LB

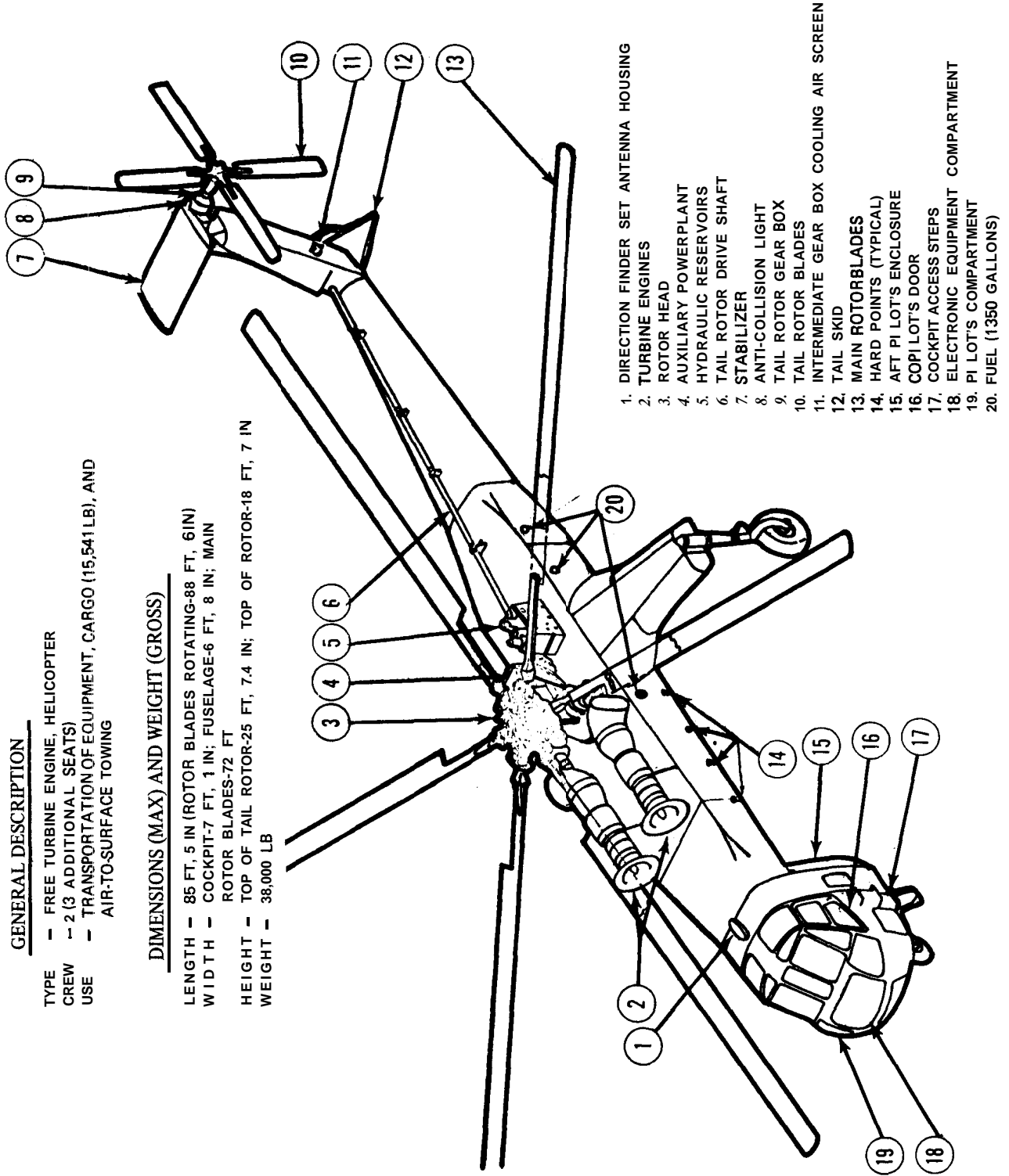

- 1. DIRECTION FINDER SET ANTENNA HOUSING
- 2. TURBINE ENGINES
- 3. ROTOR HEAD
- 4. AUXILIARY POWERPLANT
- 5. HYDRAULIC RESERVOIRS
- 6. TAIL ROTOR DRIVE SHAFT
- 7. STABILIZER
- 8. ANTI-COLLISION LIGHT
- 9. TAIL ROTOR GEAR BOX
- 10. TAIL ROTOR BLADES
- 11. INTERMEDIATE GEAR BOX COOLING AIR SCREEN
- 12. TAIL SKID
- 13. MAIN ROTORBLADES
- 14. HARD POINTS (TYPICAL)
- 15. AFT PI LOT'S ENCLOSURE
- 16. COPI LOT'S DOOR
- 17. COCKPIT ACCESS STEPS
- 18. ELECTRONIC EQUIPMENT COMPARTMENT
- 19. PI LOT'S COMPARTMENT
- 20. FUEL (1350 GALLONS)

Figure 5-28. Model CH-54 aircraft.

## EMERGENCY PROCEDURES

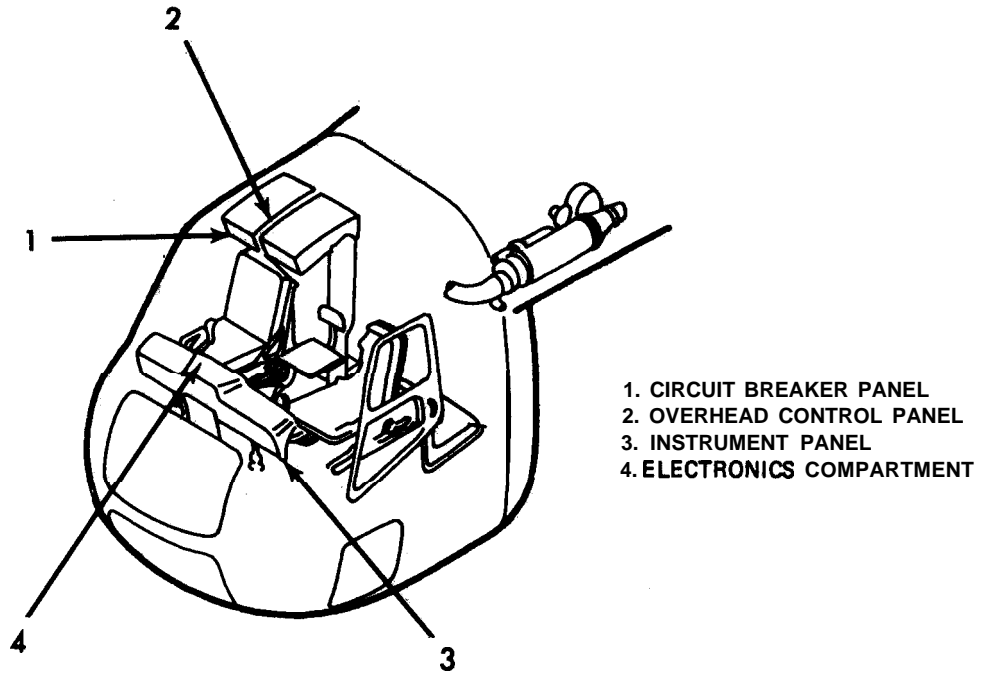

## EMERGENCY ENTRANCE

THE WINDSHIELD OR WINDOWS MAY BE BROKEN IF ENTRANCE TO THE CABIN CANNOT BE GAINED THROUGH ANY OF THE ACCESS DOORS.

Figure 5-28. Model CH-54 aircraft—Continued.

GENERAL DESCRIPTION

- TYPE -- SINGLE ENGINE, HELICOPTER
- CREW -- 1 OR 2
- PASSENGERS -- 7 (LITTERS-2) (UH-1B)

DIMENSIONS (MAX) AND WEIGHT (GROSS)

- LENGTH -- 52 FT, 10.24 IN (MODEL UH-1A)
- 52 FT, 10.84 IN (MODEL UH-1B)
- WIDTH -- 43 FT, 9 IN (MODEL UH-1A)
- 44 FT, (MODEL UH-1B)
- HEIGHT -- 11 FT, 4.57 IN (MODEL UH-1A)
- 13 FT, 2.02 IN (MODEL UH-1B)
- WEIGHT -- 5600 TO 7200 LB (UH-1A)
- 6600 TO 8600 LB (UH-1B)

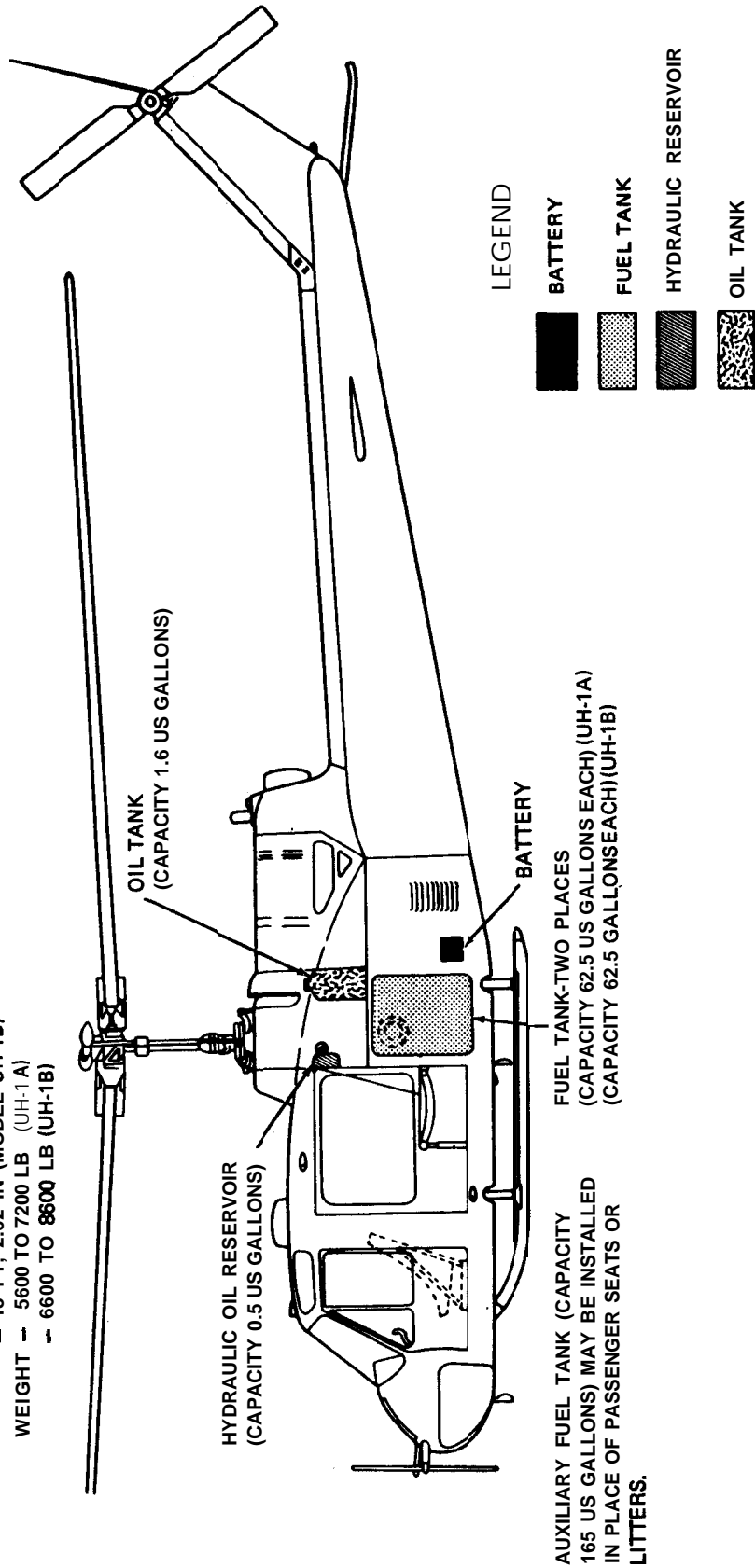
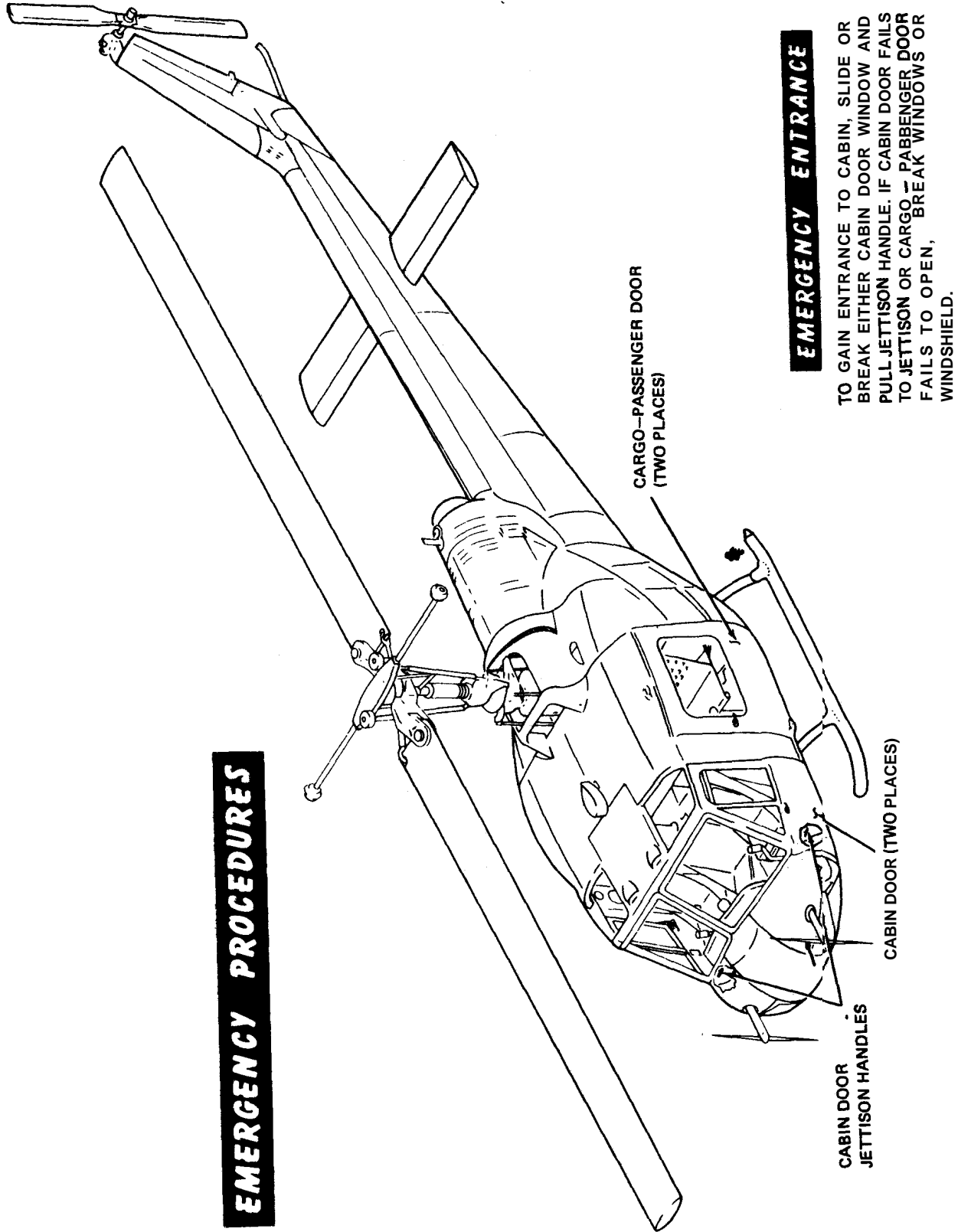

Figure 5-29. Models UH-1A and UH-1B aircraft.



**EMERGENCY PROCEDURES**

**EMERGENCY ENTRANCE**

TO GAIN ENTRANCE TO CABIN, SLIDE OR BREAK EITHER CABIN DOOR WINDOW AND PULL JETTISON HANDLE. IF CABIN DOOR FAILS TO JETTISON OR CARGO-PASSENGER DOOR FAILS TO OPEN, BREAK WINDOWS OR WINDSHIELD.

CARGO-PASSENGER DOOR  
(TWO PLACES)

CABIN DOOR  
JETTISON HANDLES

CABIN DOOR (TWO PLACES)

Figure 5-29. Models UH-1A and UH-1B aircraft—Continued.

**GENERAL DESCRIPTION**

TYPE — SINGLE TURBINE ENGINE, HELICOPTER  
 CREW - 3  
 PASSENGERS - 10

**DIMENSIONS (MAX) AND WEIGHT (GROSS)**

LENGTH — 57 FT, 11IN  
 WIDTH — 8 FT, 4 IN  
 HEIGHT — 12 FT, 6 IN  
 WEIGHT — 9500 LB

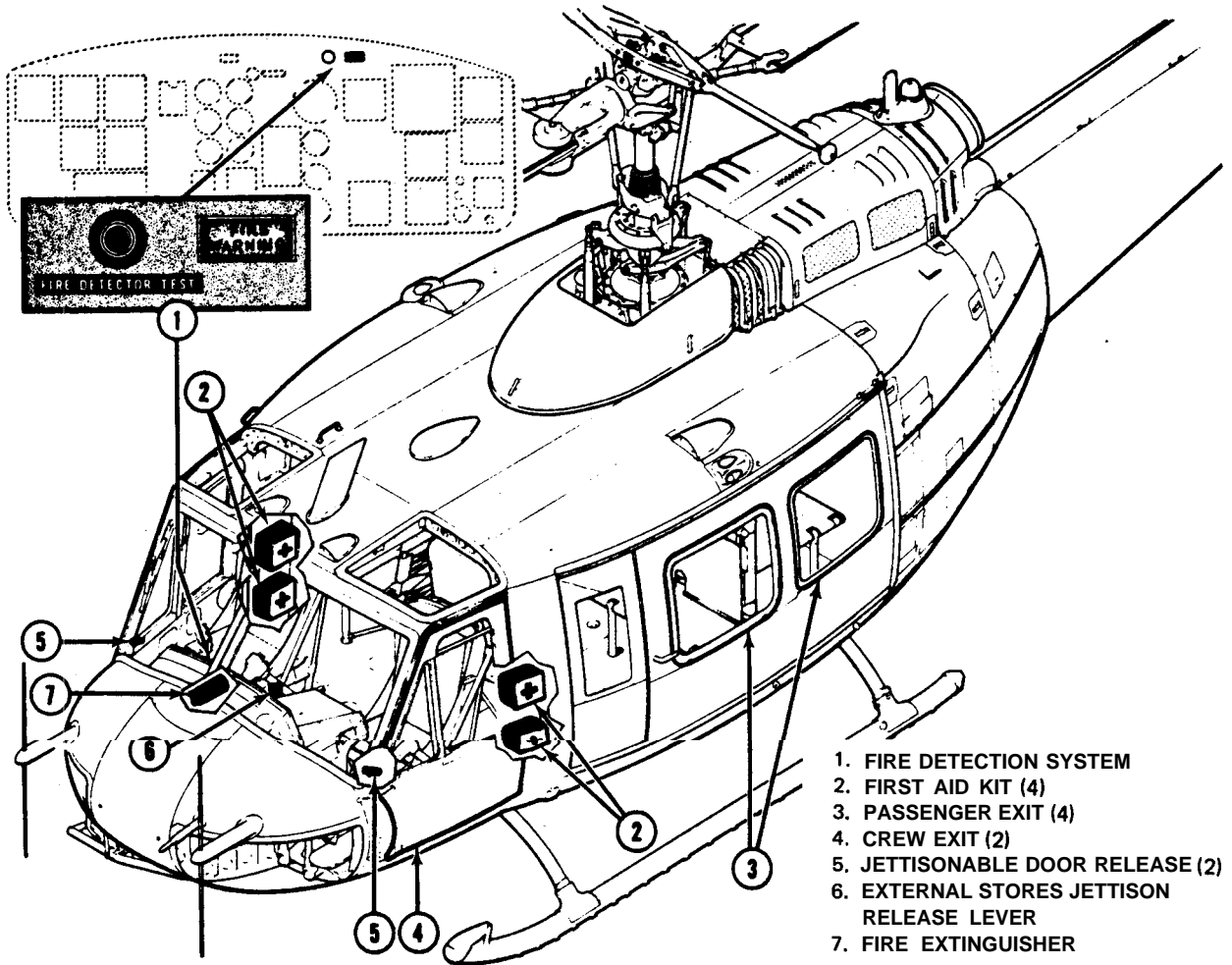

- 1. FIRE DETECTION SYSTEM
- 2. FIRST AID KIT (4)
- 3. PASSENGER EXIT (4)
- 4. CREW EXIT (2)
- 5. JETTISONABLE DOOR RELEASE (2)
- 6. EXTERNAL STORES JETTISON RELEASE LEVER
- 7. FIRE EXTINGUISHER

**EMERGENCY ENTRANCE**

TO GAIN ENTRANCE TO THE CABIN IN THE EVENT OF AN EMERGENCY, SLIDE OPEN OR BREAK THE PILOT'S OR CO-PILOT'S SLIDE WINDOW AND REACH FORWARD AND PULL THE JETTISONABLE DOOR RELEASE. IF DOOR WILL NOT JETTISON OR CARGO DOOR WILL NOT OPEN, BREAK DOOR WINDOWS OR WINDSHIELD TO GAIN ENTRANCE.

Figure 5-30. Models UH-1D and UH-1H aircraft.

GENERAL DESCRIPTION

TYPE - SINGLE ENGINE, HELICOPTER  
 CREW - 2  
 PASSENGERS - 0

DIMENSIONS (MAX) AND WEIGHT (GROSS)

LENGTH - 52 FT, 11 65/100 IN  
 WIDTH - 10 FT, 4 IN  
 HEIGHT - 11 FT, 7 IN  
 WEIGHT - 9500 LB

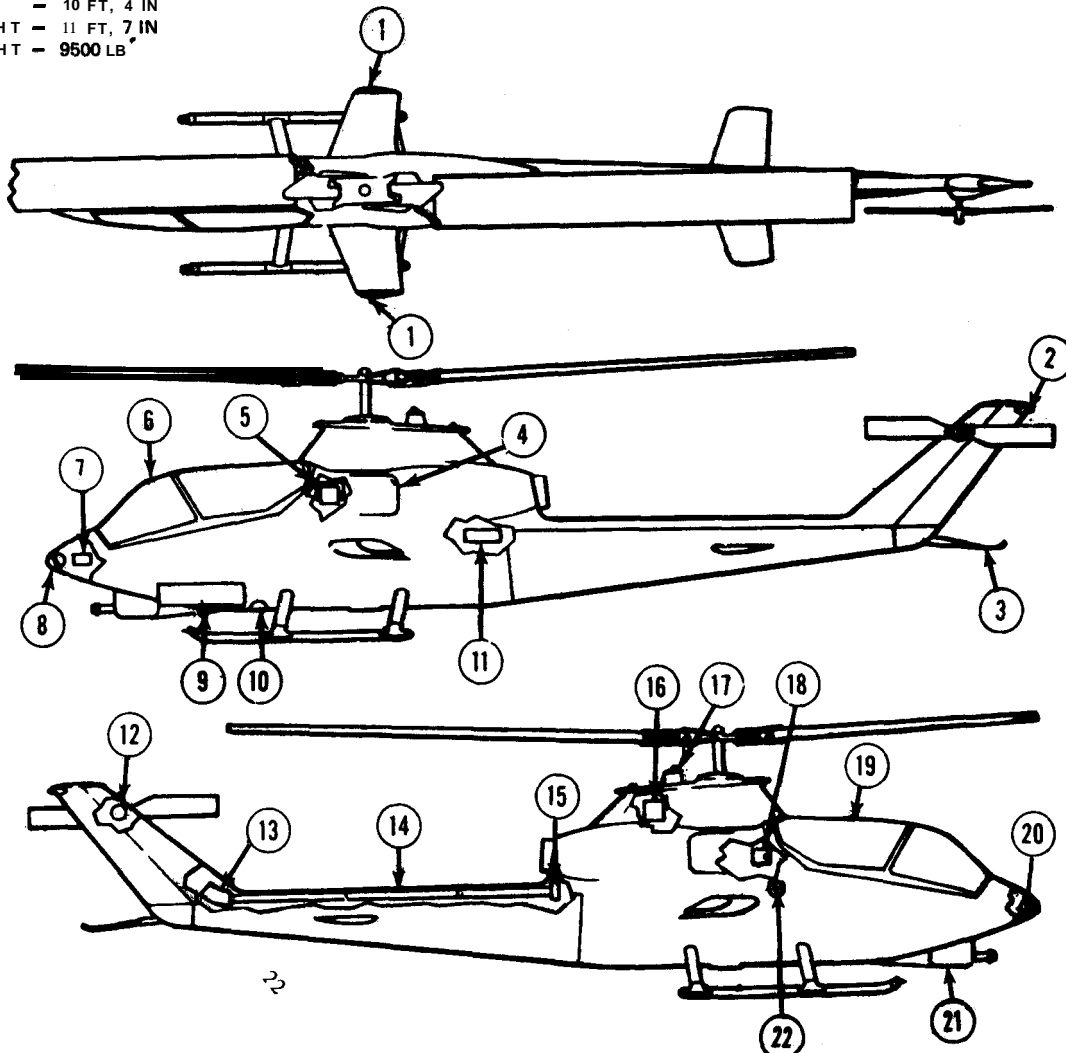

- |                             |  |  |
|-----------------------------|--|--|
| 1. WING TIP POSITION LIGHTS | 10. SEARCHLIGHT                                    | 18. HYDRAULIC RESERVOIR-2 (3.2 PINTS EACH) |
| 2. AFT POSITION LIGHT       | 11. ENGINE AND TRANSMISSION OIL COOLER             | 19. PILOT'S CANOPY HATCH                   |
| 3. TAIL SKID                | 12. 90 DEGREES GEAR BOX                            | 20. RIGHT LANDING LIGHT                    |
| 4. ENGINE AIR INLET         | 13. 42 DEGREES GEAR BOX                            | 21. TAT-102A OR XM-28 TURRET               |
| 5. HYDRAULIC RESERVOIR      | 14. TAIL ROTOR DRIVE SHAFT                         | 22. FUEL FILLER CAP                        |
| 6. GUNNER'S CANOPY HATCH    | 15. TRANSMISSION COMPARTMENT AND OIL COOLER BLOWER | (TANK CAPACITY-265 GALLONS)                |
| 7. BATTERY                  | 16. ENGINE OIL TANK (3.4 GALLONS)                  |  |
| a LEFT LANDING LIGHT        | 17. ANTI-COLLISION LIGHT                           |  |
| 9. AMMUNITION COMPARTMENT   |  |  |

Figure 5-31. Model AH-1G aircraft



## EMERGENCY PROCEDURES

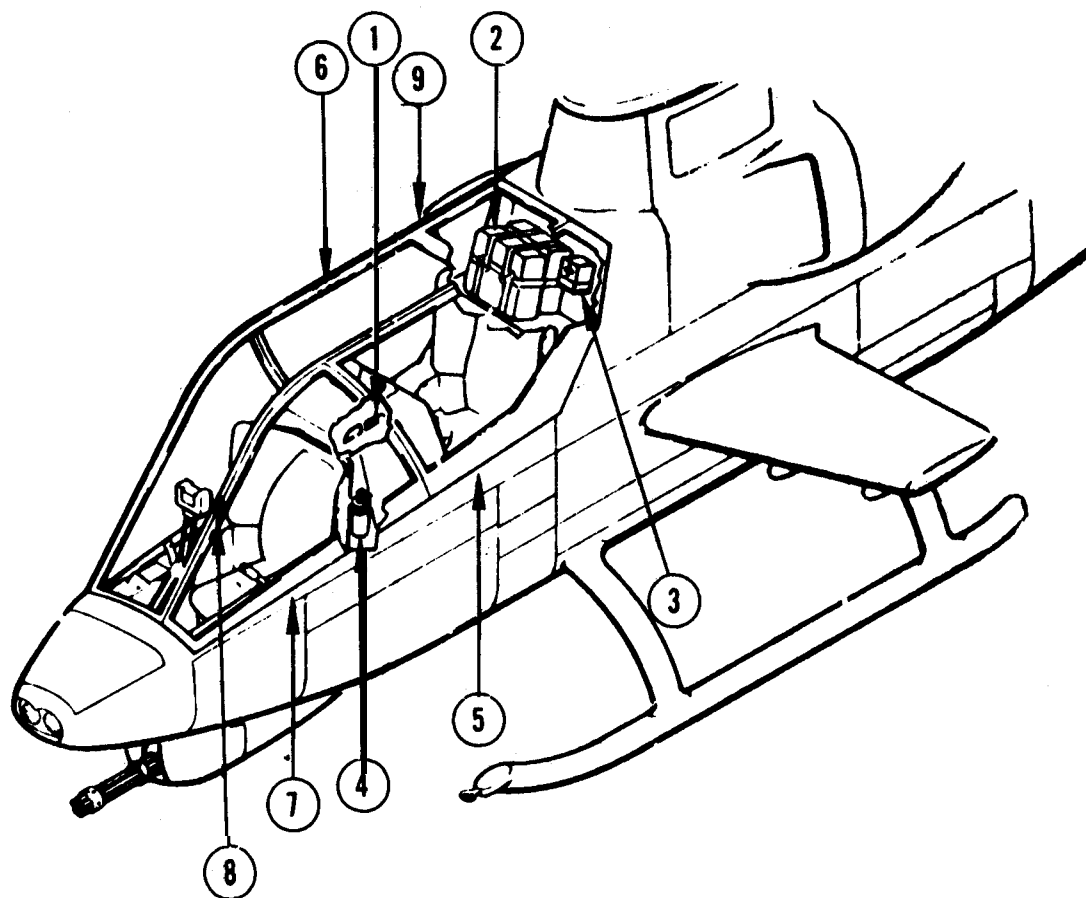

- |                                       |   |
|---------------------------------------|---|
| 1. KNIFE -- CANOPY BREAKOUT           | 6. CANOPY JETTISONABLE RELEASE (PILOT'S)  |
| 2. SURVIVAL KITS STOWAGE (PROVISIONS) | 7. GUNNER'S CANOPY DOOR                   |
| 3. FIRST AID KIT                      | 8. CANOPY JETTISONABLE RELEASE (GUNNER'S) |
| 4. FIRE EXTINGUISHER                  | 9. CANOPY AREA                            |
| 5. PILOT'S CANOPY DOOR                |   |

## EMERGENCY ENTRANCE

WINDOWS AND WINDSHIELDS MAY BE BROKEN IF ENTRANCE TO THE CABIN THROUGH THE DOORS IS NOT POSSIBLE.

Figure 5-31. Model AH-1G aircraft—Continued.

GENERAL DESCRIPTION

TYPE -- SINGLE ENGINE, HELICOPTER, PRIMARY TRAINER  
 CREW -- 1  
 PASSENGERS -- 1

DIMENSIONS (MAX) AND WEIGHT (GROSS)

LENGTH -- 28 FT, 10 3/4 IN  
 WIDTH -- 25 FT, 3 1/2 IN  
 HEIGHT -- 8 FT, 2 5/8 IN  
 WEIGHT -- 1670 LB

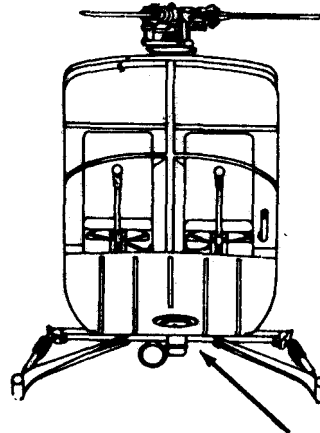

EXTERIOR BATTERY - SECURED TO RIGHT AFT FUSELAGE STRUT

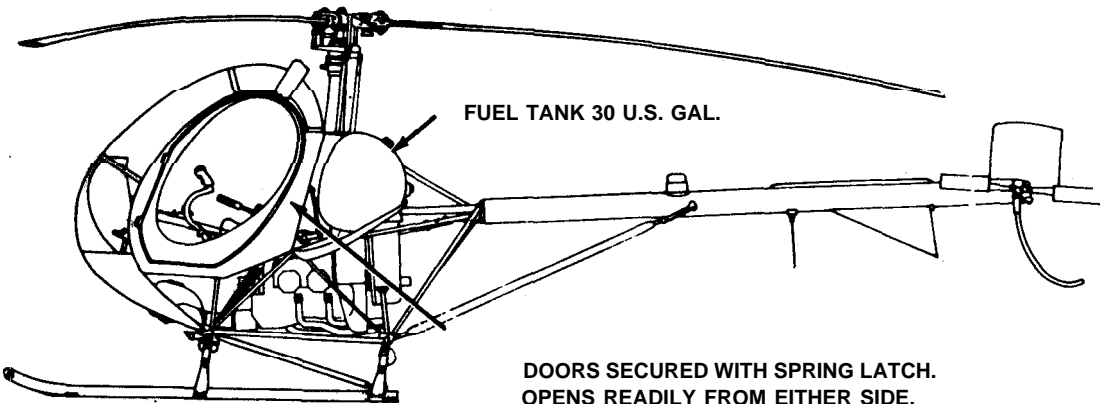
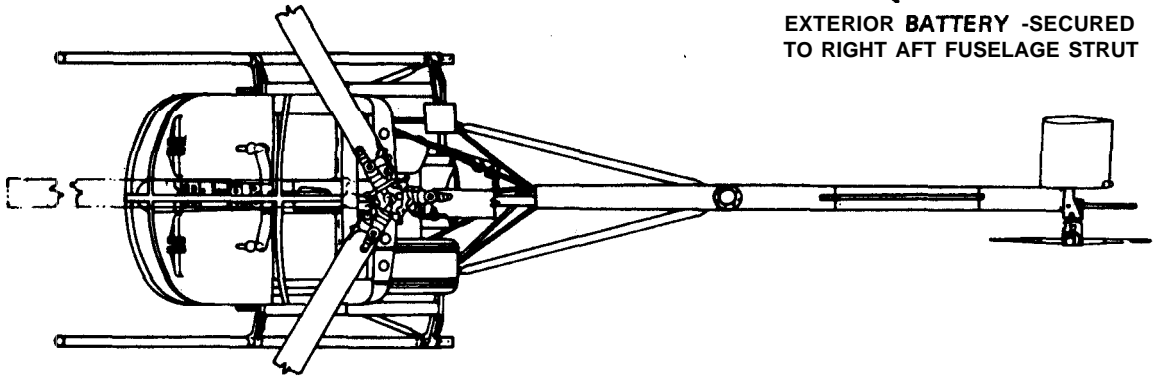

FUEL TANK 30 U.S. GAL.

DOORS SECURED WITH SPRING LATCH. OPENS READILY FROM EITHER SIDE.

**EMERGENCY ENTRANCE**

WINDOWS AND WINDSHIELD MAY BE BROKEN IF ENTRANCE TO THE CABIN THROUGH THE DOOR IS NOT POSSIBLE.

Figure 5-32. Model TH-55 aircraft.

GENERAL DESCRIPTION

- TYPE - SINGLE ENGINE, LIAISON
- CREW - 1
- PASSENGERS - 1

DIMENSIONS AND WEIGHT (GROSS)

- LENGTH - 25 FT, 9.5 IN
- WING SPAN - 36 FT
- HEIGHT - 7 FT, 6 IN
- WEIGHT - 2100 LB (MODEL 0-1A)
- 2166 LB (MODEL 0-1E)
- 2400 LB (MODEL T0-1D)

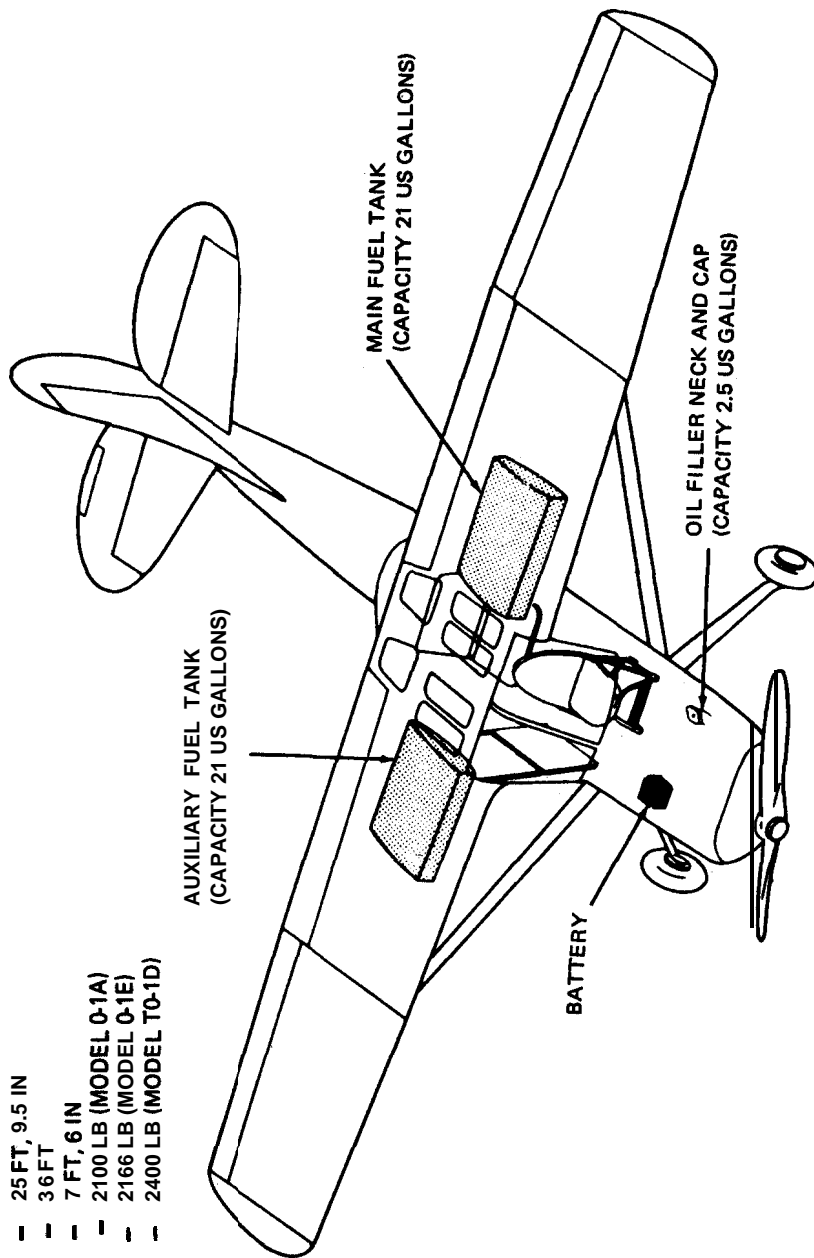

**LEGEND**

- BATTERY
- FUEL TANK

Figure 5-38. Models 0-1A, 0-1E, 0-1F, TO-1A, TO-1D, TO-1E aircraft.

**EMERGENCY PROCEDURES**

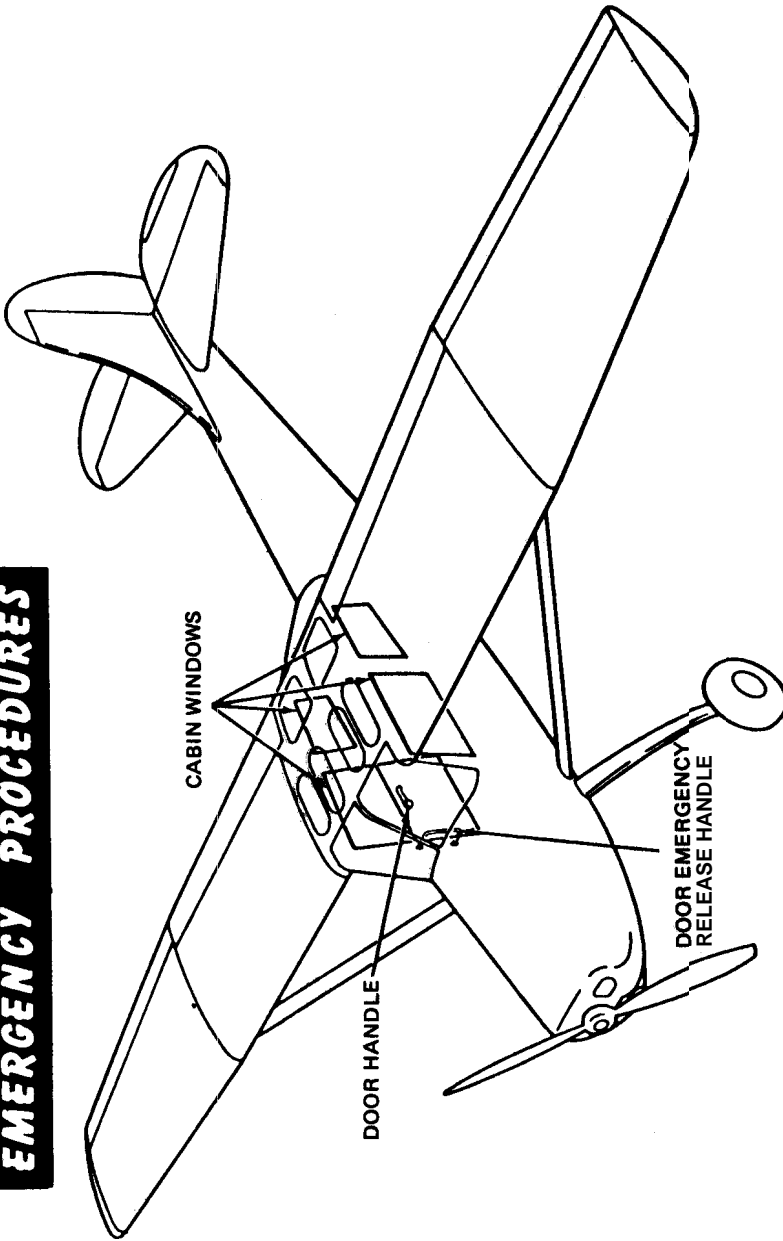

**EMERGENCY ENTRANCE**

EMERGENCY ENTRANCE. MAY BE ACCOMPLISHED BY TURNING DOOR HANDLE TO RELEASE DOOR AND WINDOW. IF DOOR CANNOT BE OPENED, BREAK CABIN WINDOWS, AFTER ENTRANCE IS ACCOMPLISHED, DOOR MAY BE JETTISONED BY DISENGAGING LOWER END OF DOOR EMERGENCY RELEASE HANDLE, TURNING IT CLOCKWISE, AND PUSHING OUTWARD ON DOOR.

Figure 5-33. Models 0-1 A, 0-1 E, 0-1 F, TO-1 A, TO-1 D, TO-1 E aircraft--Continued.

**GENERAL DESCRIPTION**

**TYPE** - SINGLE ENGINE, PRIMARY **TRAINER**  
**CREW** - 1  
**PASSENGERS** - 3

**DIMENSIONS (MAX) AND WEIGHT (GROSS)**

**LENGTH** - 26 FT, 5 IN  
**WING SPAN** - 36 FT, 2 IN  
**HEIGHT** - 8 FT, 11 IN  
**WEIGHT** - 2500 LB

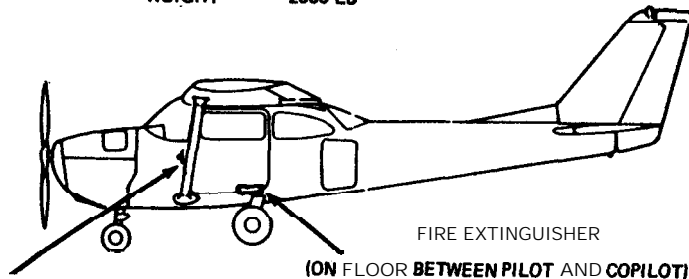

DOOR JETTISON HANDLE  
 (INSIDE BOTH DOORS)

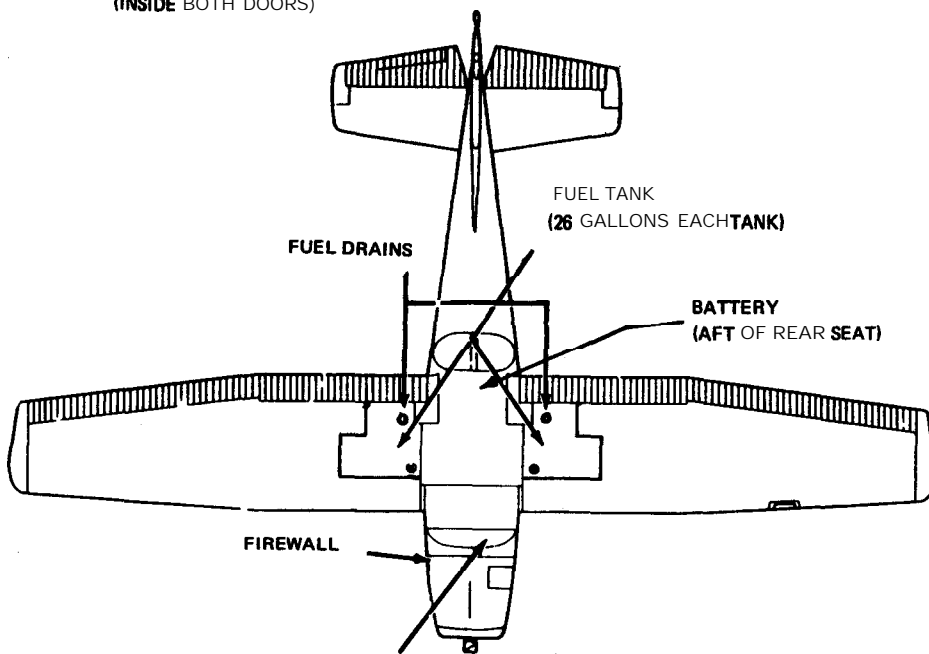

MASTER SWITCH  
 (LOWER CENTER OF INSTRUMENT PANEL)

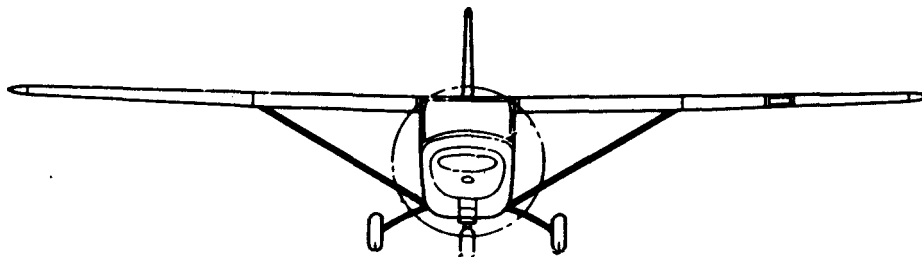

**EMERGENCY ENTRANCE**

WINDSHIELD OR WINDOWS MAY BE BROKEN IF ENTRANCE THROUGH THE DOOR IS NOT POSSIBLE.

Figure 5-34. Model T-41B aircraft.

GENERAL DESCRIPTION

TYPE - TWIN ENGINE, INSTRUMENT TRAINER  
CREW - 1  
PASSENGERS - 3

DIMENSIONS (MAX) AND WEIGHT (GROSS)

LENGTH - 27 FT, 3 IN  
WING SPAN - 37 FT, 10 IN  
HEIGHT - 9 FT, 7 IN  
WEIGHT - 3480 LB

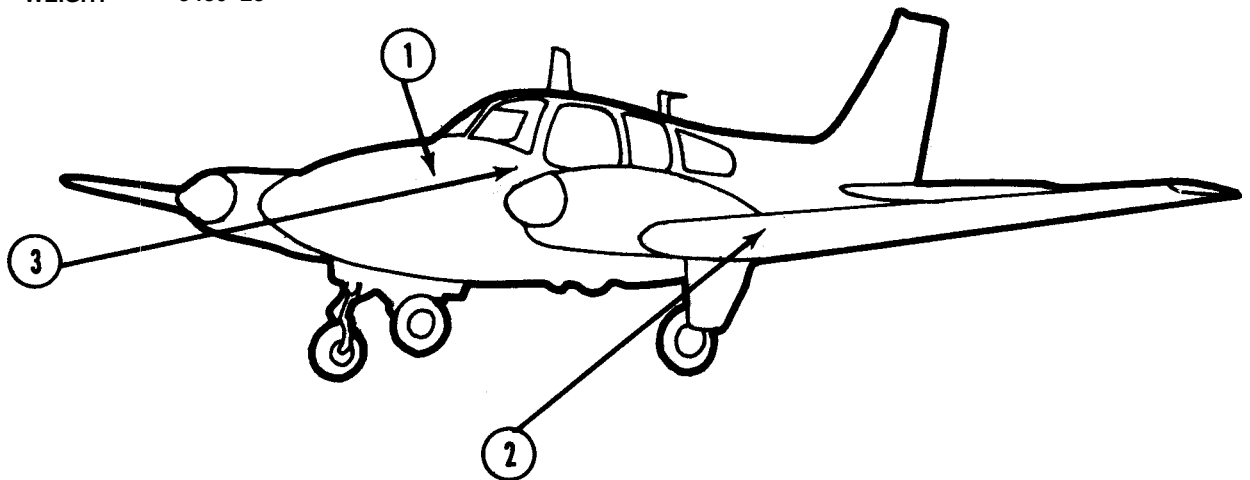

- 1. MAIN FUEL TANK (142 GALLONS)
- 2. AUXILLARY FUEL TANK
- 3. IGNITION SWITCH (EXTREME LEFT OF INSTRUMENT PANEL)

**EMERGENCY ENTRANCE**

THE WINDSHIELD OR WINDOWS MAY BE BROKEN IF ENTRANCE TO THE CABIN CANNOT BE GAINED THROUGH THE DOOR.

Figure 5-35. Model T-42A aircraft.

**GENERAL DESCRIPTION**

TYPE - SINGLE ENGINE, LIAISON  
 CREW - 1  
 PASSENGERS - 5 (LITTERS-2)

**DIMENSIONS AND WEIGHT (GROSS)**

LENGTH - 30 FT, 5 IN  
 WINGSPAN - 48 FT  
 HEIGHT - 10 FT, 5 IN  
 WEIGHT - 5100 LB

WING TIP FUEL TANK - SOME AIRCRAFT  
 (CAPACITY 21.5 US GALLONS) •

HYDRAULIC RESERVOIR  
 (LOCATED IN PILOT'S COMPARTMENT)

OIL TANK  
 (LOCATED IN PILOT'S COMPARTMENT)

WING TIP FUEL TANK -  
 SOME AIRCRAFT  
 (CAPACITY 21.5 US  
 GALLONS)

FWD FUEL TANK  
 (CAPACITY 35.7 US GALLONS)

CENTER FUEL TANK  
 (CAPACITY 35.6 US GALLONS)





AFT FUEL TANK  
 (CAPACITY 25.5 US GALLONS)

BELLY FUEL TANK - SOME AIRCRAFT  
 (CAPACITY 43 US GALLONS)

BATTERY

BATTERY ACCESS DOOR

**LEGEND**

	BATTERY
	FUEL TANK
	HYDRAULIC RESERVOIR
	OIL TANK

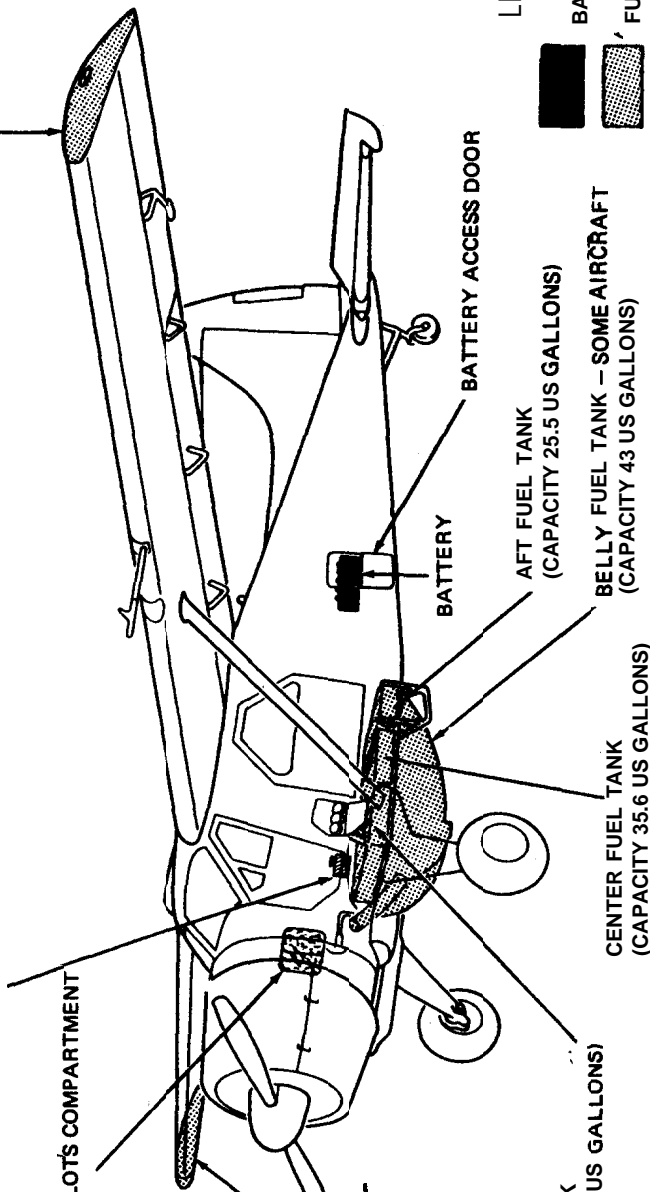
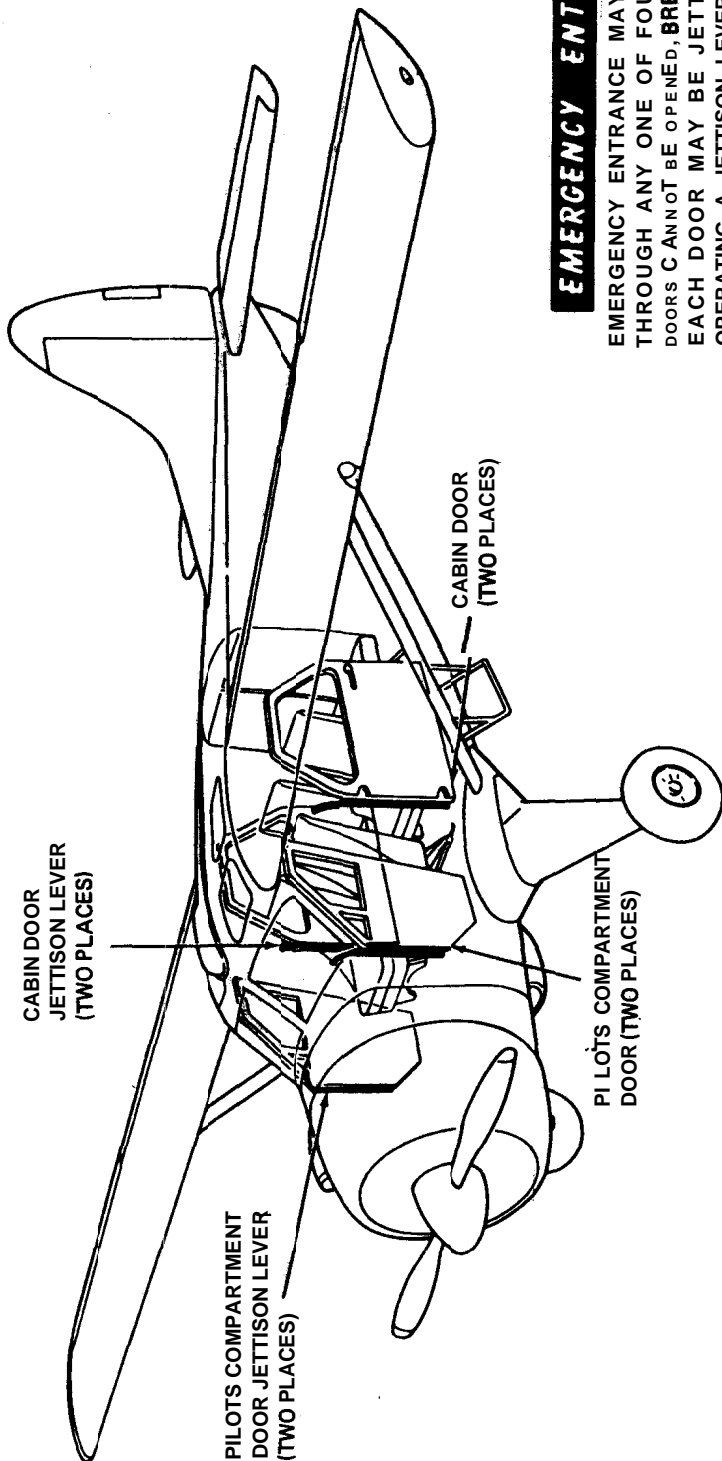

Figure 5-36. Model U-89 aircraft.

**EMERGENCY PROCEDURES**



**EMERGENCY ENTRANCE**

EMERGENCY ENTRANCE MAY BE GAINED THROUGH ANY ONE OF FOUR DOORS. IF DOORS CANNOT BE OPENED, BREAK WINDOWS. EACH DOOR MAY BE JETTISONED BY OPERATING A JETTISON LEVER, LOCATED AT HINGE SIDE OF DOOR. TO OPERATE PILOTS COMPARTMENT DOOR JETTISON LEVER, PULL AFT ON LEVER AND PUSH OUTWARD ON DOOR. TO OPERATE CABIN DOOR JETTISON LEVER, PULL LEVER AFT OR PUSH FORWARD, BEFORE PUSHING DOOR OUTWARD.

Figure 5-36. Model U-6A aircraft-Continued.



GENERAL DESCRIPTION

TYPE -- TWIN ENGINE, LIAISON  
 CREW - 1  
 PASSENGERS -- 5

DIMENSIONS AND WEIGHT (GROSS)

LENGTH -- 31 FT, 6 IN  
 WING SPAN -- 45 FT, 3.6 IN  
 HEIGHT -- 11 FT, 6 IN  
 WEIGHT -- 7000 LB

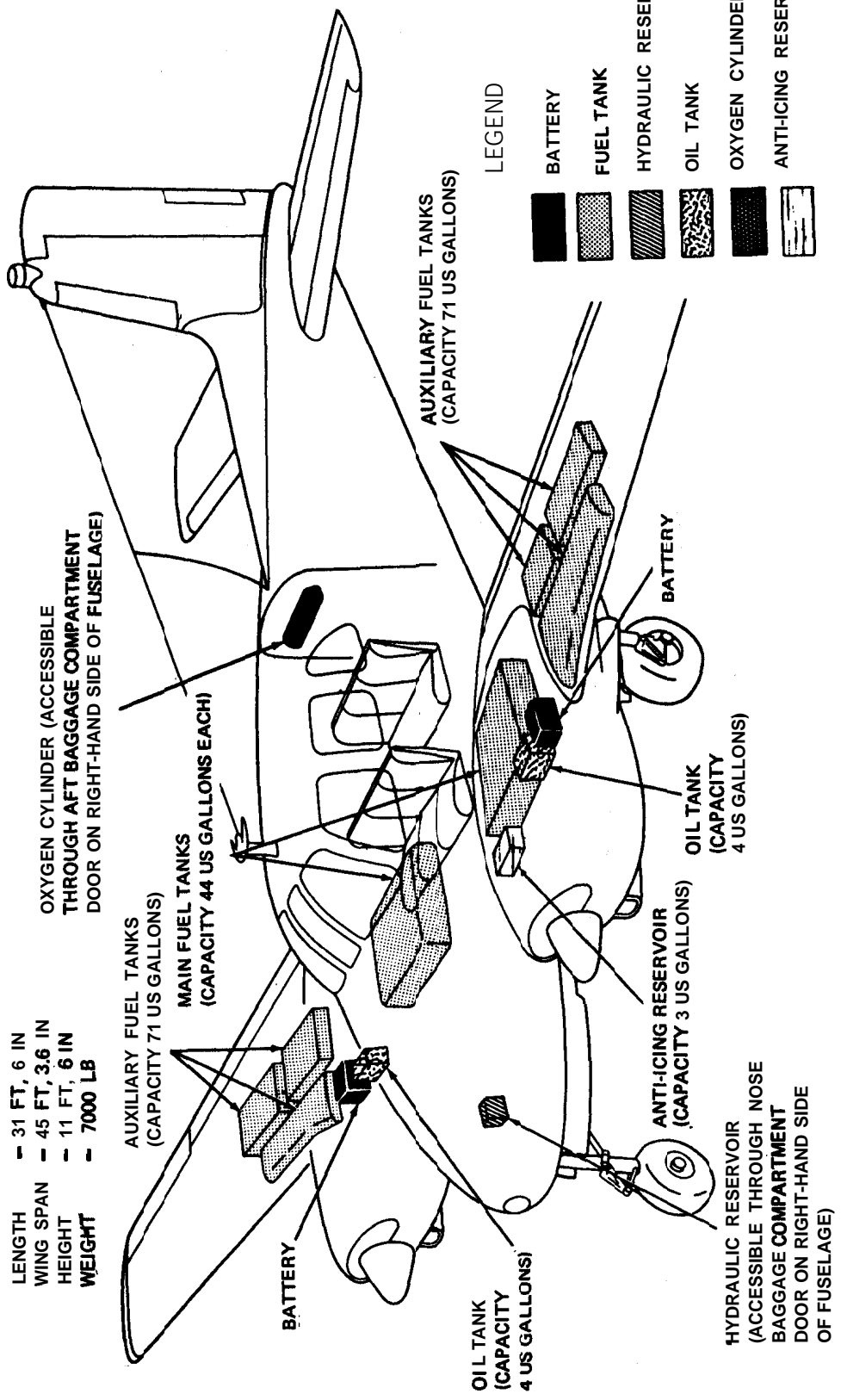
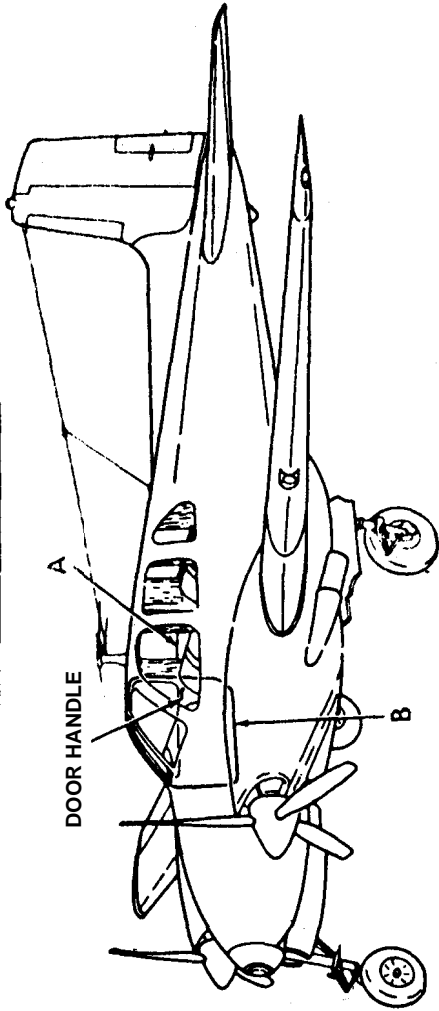

Figure 5-37. Models U-8D and BU-8D aircraft.

**EMERGENCY PROCEDURES**



1. PUSH LATCH IN



2. LIFT HANDLE



4. PUSH WINDOW OUT

3. PULL RELEASE PIN OUT

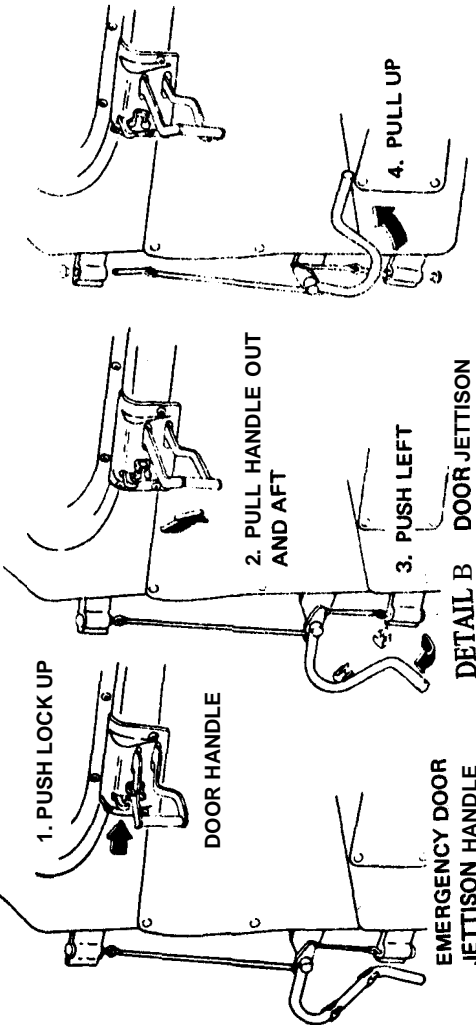

DETAIL A

WINDOW RELEASE

**EMERGENCY ENTRANCE**

EMERGENCY ENTRANCE IS GAINED THROUGH DOOR ON RIGHT-HAND SIDE OF CABIN. DOOR IS OPENED BY TURNING DOOR HANDLE. IF DOOR FAILS TO OPEN, CENTER WINDOW MAY BE BROKEN TO GAIN ACCESS TO WINDOW RELEASE PINS. (SEE DETAIL A.) AFTER ENTRANCE IS ACCOMPLISHED, DOOR MAY BE JETTISONED. (SEE DETAIL B.) BROKEN YELLOW LINES SURROUNDING RIGHT-HAND AFT WINDOW INDICATE WHERE FUSELAGE MAY BE CUT IF DOOR OR WINDOWS FAIL TO OPEN.

Figure 5-37. Models U-8D and RU-8D aircraft-continued.

GENERAL DESCRIPTION

TYPE - TWIN ENGINE, LIAISON  
 CREW - 2  
 PASSENGERS - 4

DIMENSIONS AND WEIGHT (GROSS)

LENGTH - 33 FT, 2 IN  
 WING SPAN - 45 FT, 10.5 IN  
 HEIGHT - 14 FT, 2 IN  
 WEIGHT - 7700 LB

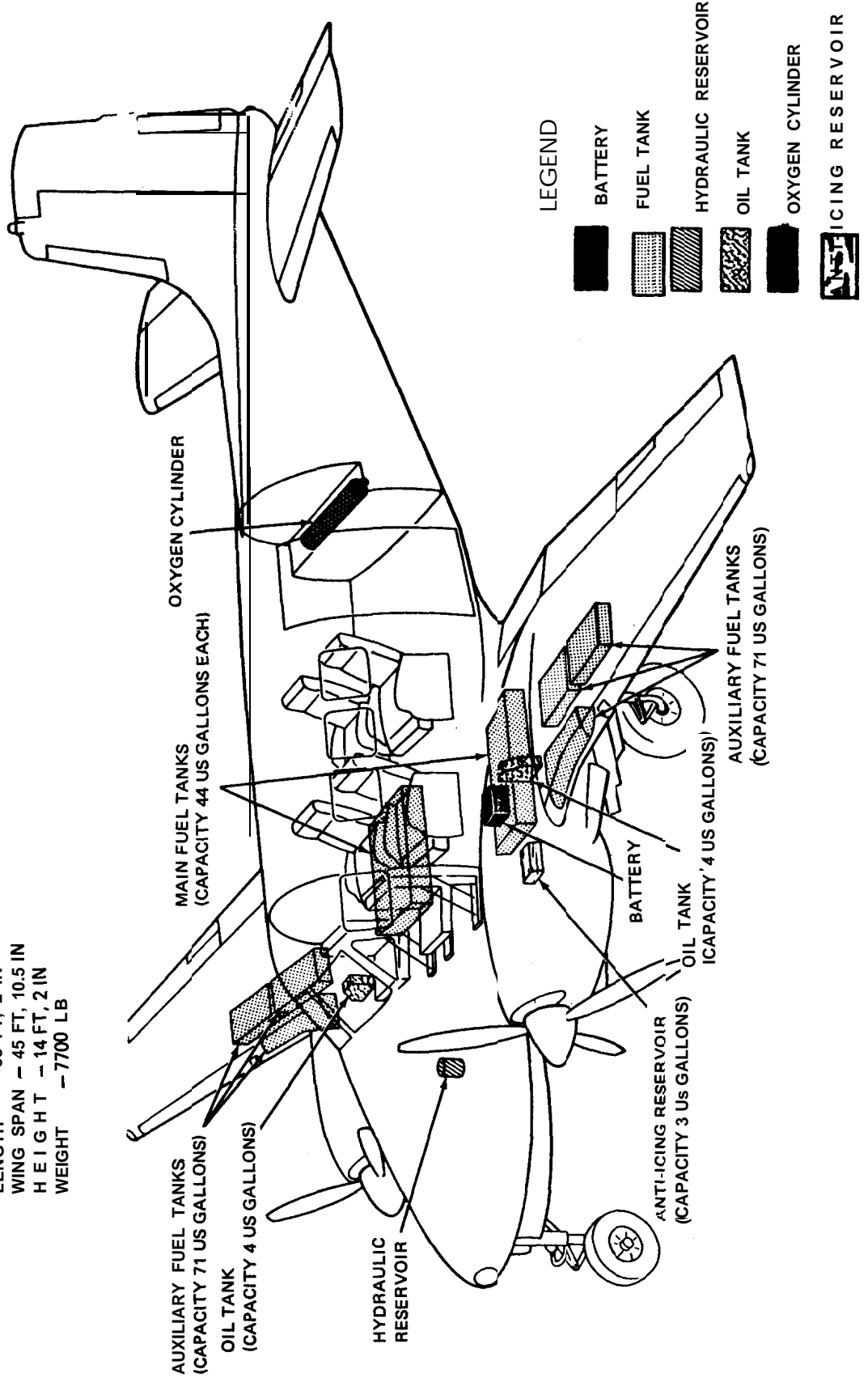
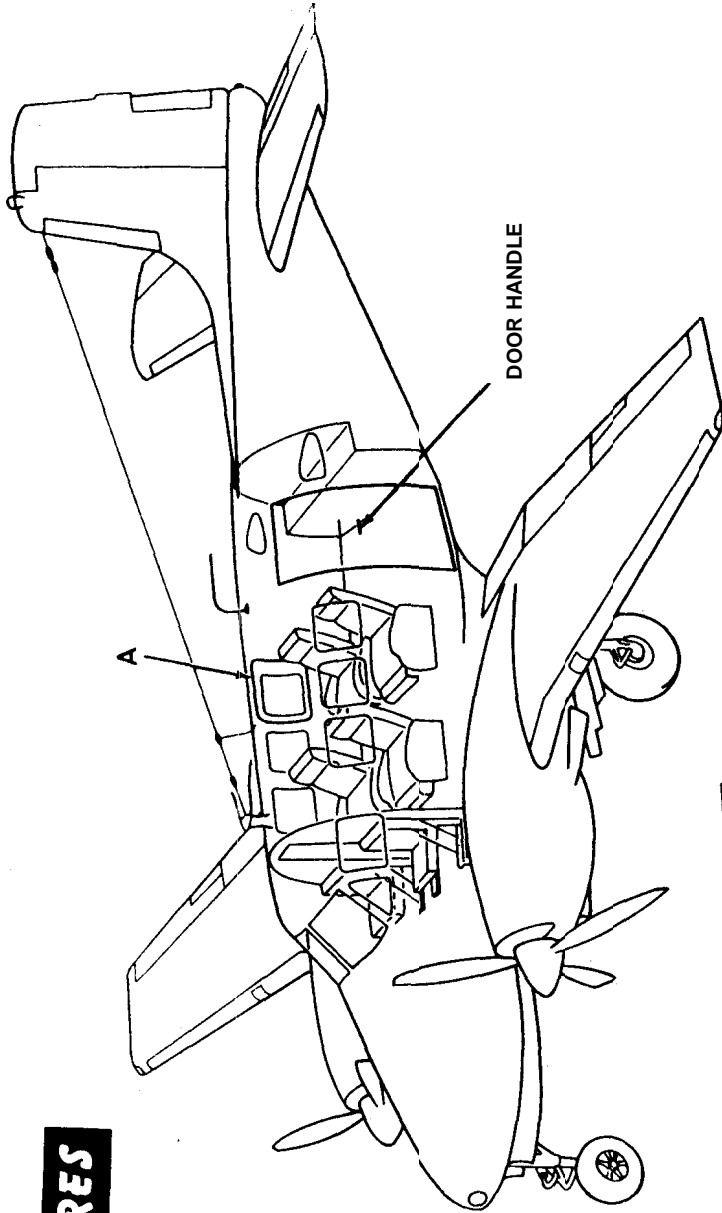

Figure 5-38. Models U-8F and U8G aircraft.

**EMERGENCY PROCEDURES**



DOOR HANDLE

A

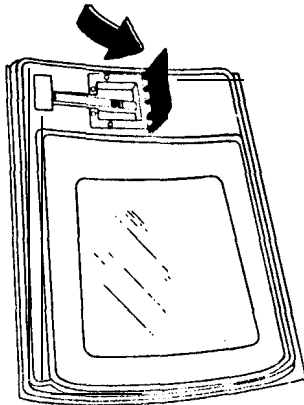

1. PULL DOWN RED COVER OVER HANDLE

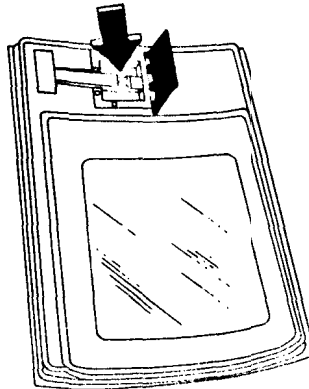

2. PUSH RED BUTTON TO RELEASE HANDLE

DETAIL A  
ESCAPE HATCH

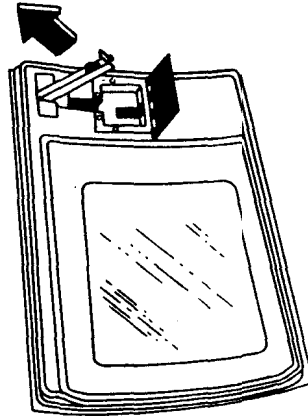

3. PULL UP ON HANDLE AND PUSH OUTWARD ON HATCH

**EMERGENCY ENTRANCE**

EMERGENCY ENTRANCE IS GAINED THROUGH DOOR ON LEFT-HAND SIDE OF CABIN. DOOR IS OPENED BY TURNING DOOR HANDLE. IF DOOR FAILS TO OPEN, BREAK WINDOWS. AFTER ENTRANCE IS ACCOMPLISHED, ESCAPE HATCH MAY BE JETTISONED. (SEE DETAIL A.) DOOR IS ALSO PROVIDED WITH INTERNAL RELEASE.

Figure 548. Models U-8F and U8G aircraft—Continued.

GENERAL DESCRIPTION

TYPE - SINGLE ENGINE, UTILITY  
 CREW - 1  
 PASSENGERS - 10 (LITTERS-4)

DIMENSIONS AND WEIGHT (GROSS)

LENGTH - 41 FT, 10 IN  
 WING SPAN - 58 FT  
 HEIGHT - 12 FT, 51 IN  
 WEIGHT - 8000 LB

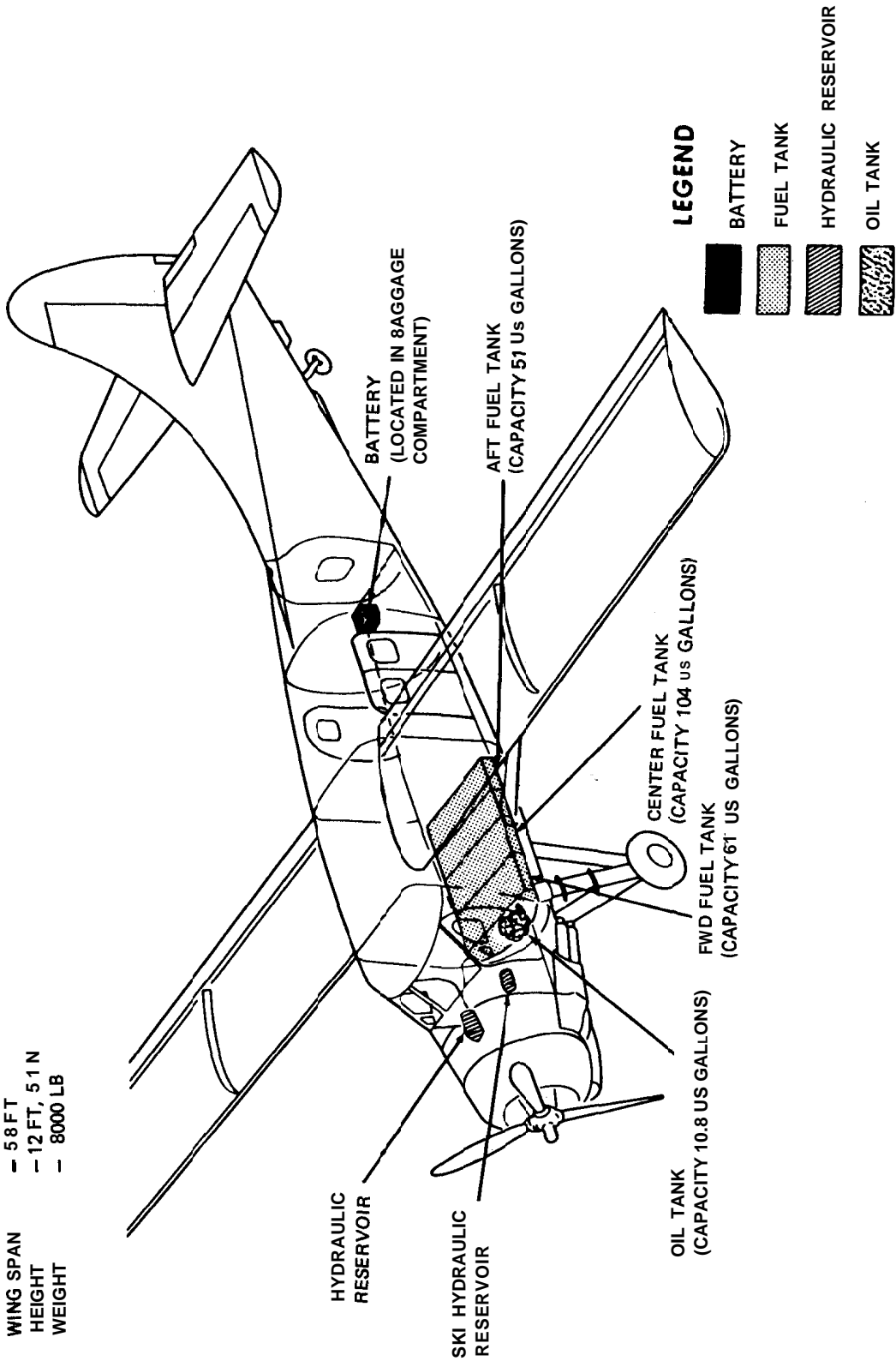
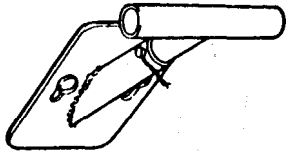
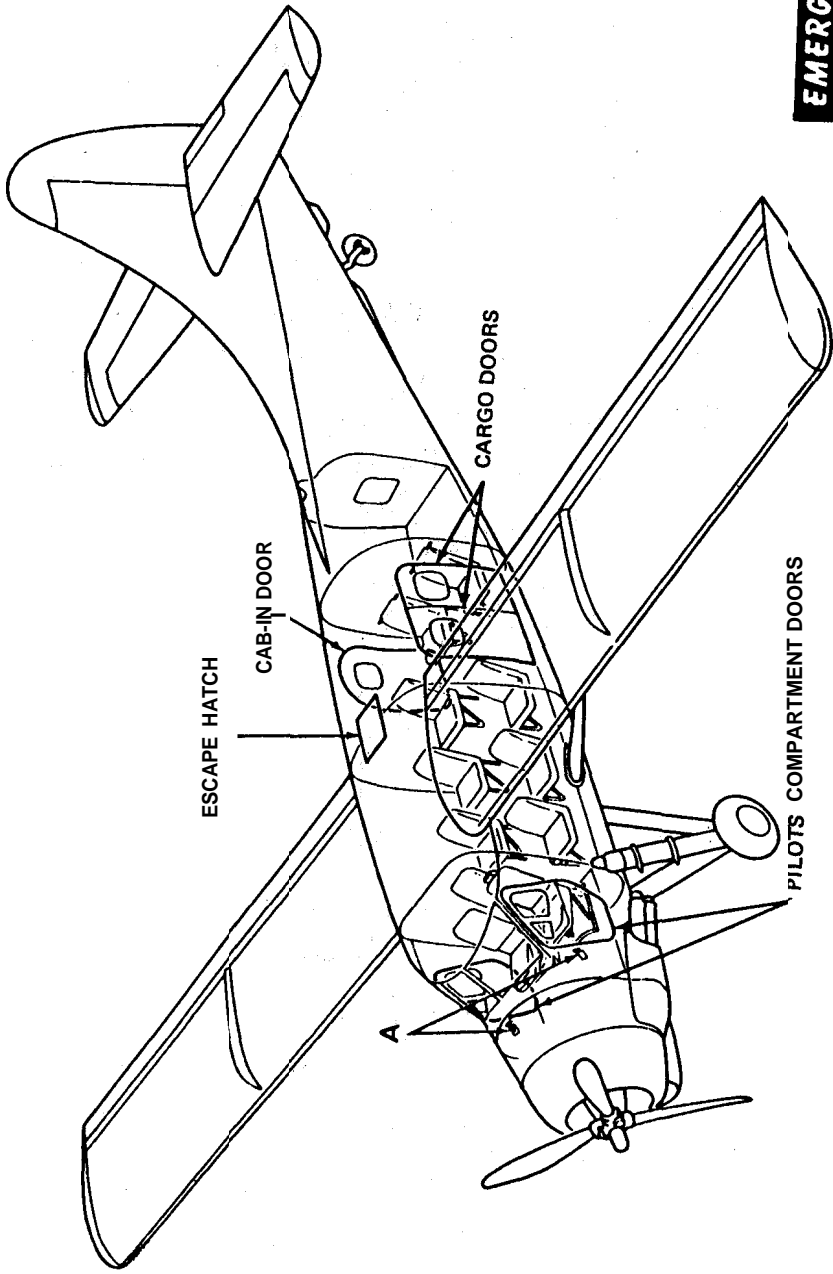

Figure 5-39. Model U-1A aircraft.

**EMERGENCY PROCEDURES**



**DETAIL A**  
PILOT'S COMPARTMENT  
DOOR JETTISON HANDLE



**EMERGENCY ENTRANCE**

EMERGENCY ENTRANCE MAY BE GAINED THROUGH ANY ONE OF FIVE FUSELAGE DOORS AND ESCAPE HATCH. AFTER ENTRANCE IS ACCOMPLISHED, PILOTS COMPARTMENT DOORS MAY BE JETTISONED BY PULLING SHARPLY ON RESPECTIVE JETTISON HANDLE AND PUSHING OUTWARD ON DOOR. (SEE DETAIL A.)

Figure 5-39. Model U-1A a & raft-Continued.

GENERAL DESCRIPTION

TYPE - TWIN ENGINE, LIAISON AND LIGHT CARGO  
 CREW - 2  
 PASSENGERS - 4

DIMENSIONS (MAX) AND WEIGHT (GROSS)

LENGTH - 35 FT, 1/2 IN  
 WIDTH - 44 FT, 7 IN  
 HEIGHT - 14 FT, 6 IN  
 WEIGHT - 7000 LB

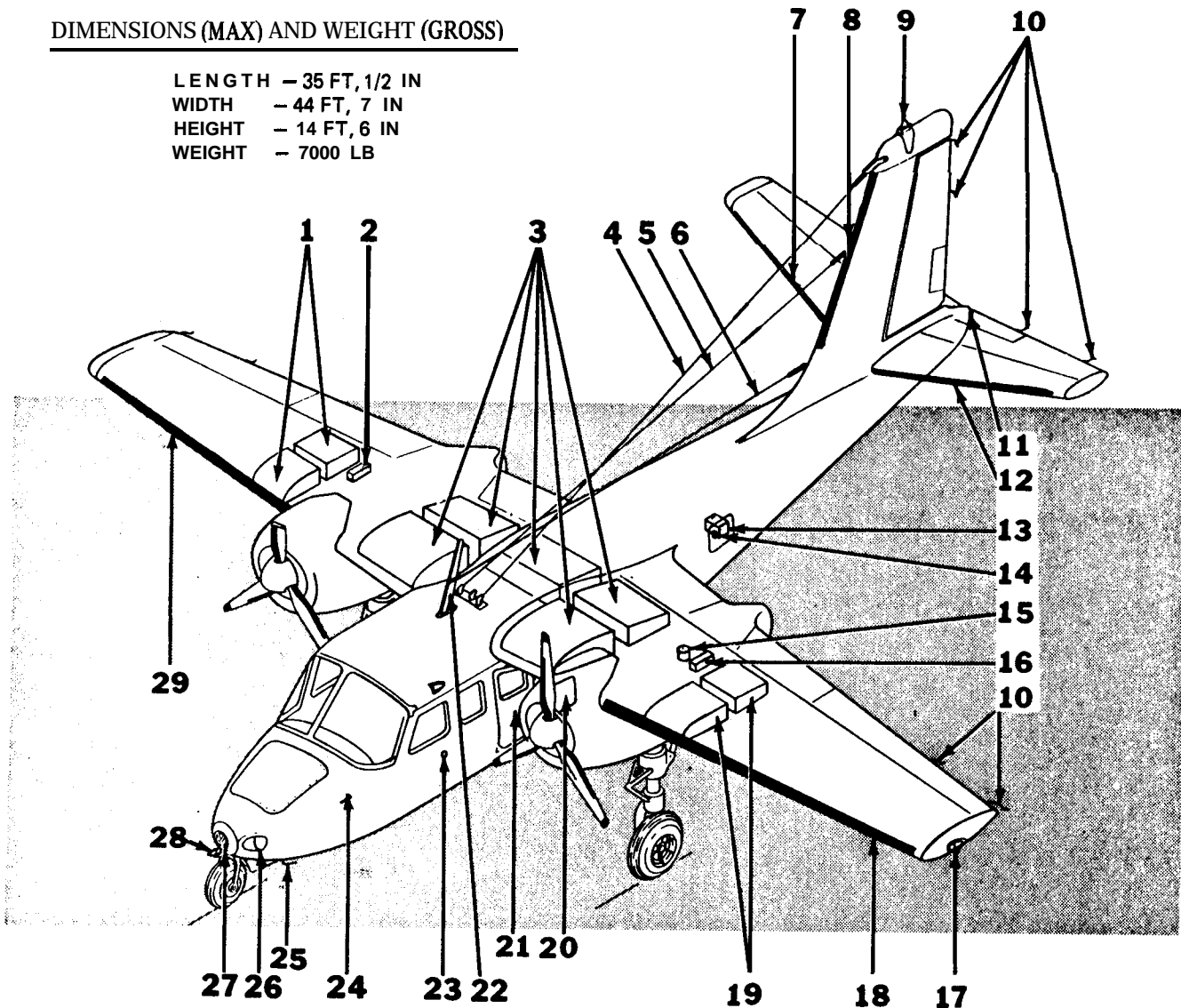

- |   |   |
|---|---|
| 1. RIGHT OUTBOARD FUEL TANK                             | 14. EXTERNAL POWER RECEPTACLE           |
| 2. RIGHT OIL TANK                                       | 15. HYDRAULIC RESERVOIR                 |
| 3. CENTER FUEL TANK                                     | 16. LEFT OIL TANK                       |
| 4. AUTOMATIC DIRECTION FINDING RECEIVER (ADF-2) ANTENNA | 17. LEFT POSITION LIGHT                 |
| 5. AUTOMATIC DIRECTION FINDING RECEIVER (ADF-1) ANTENNA | 18. LEFT WING DE-ICER BOOT              |
| 6. COMMUNICATION-NAVIGATION RADIO (LTRA-6) ANTENNA      | 19. LEFT OUTBOARD FUEL TANK             |
| 7. RIGHT HORIZONTAL STABILIZER DE-ICER BOOT             | 20. BAGGAGE COMPARTMENT DOOR            |
| 8. VERTICAL STABILIZER DE-ICER BOOT                     | 21. CABIN DOOR                          |
| 9. ROTATING BEACON                                      | 22. VHF COMMAND RADIO (LVTR-36) ANTENNA |
| 10. STATIC DISCHARGE WICK                               | 23. STATIC VENT                         |
| 11. AFT POSITION LIGHT                                  | 24. PILOTHOOD                           |
| 12. LEFT HORIZONTAL STABILIZER DE-ICER BOOT             | 25. OMNIRANGE RECEIVER ANTENNA          |
| 13. BATTERY   | 26. LEFT LANDING LIGHT                  |
|   | 27. HEATER AND VENT INTAKE DUCT         |
|   | 28. GLIDE SLOPE RECEIVER ANTENNA        |
|   | 29. RIGHT WING DE-ICER BOOT             |

Figure 5-40. Models U-9B, U-9C, and RU-9D aircraft.

# EMERGENCY PROCEDURES

GROUND AND AIR  
ESCAPE ROUTES AND EXITS

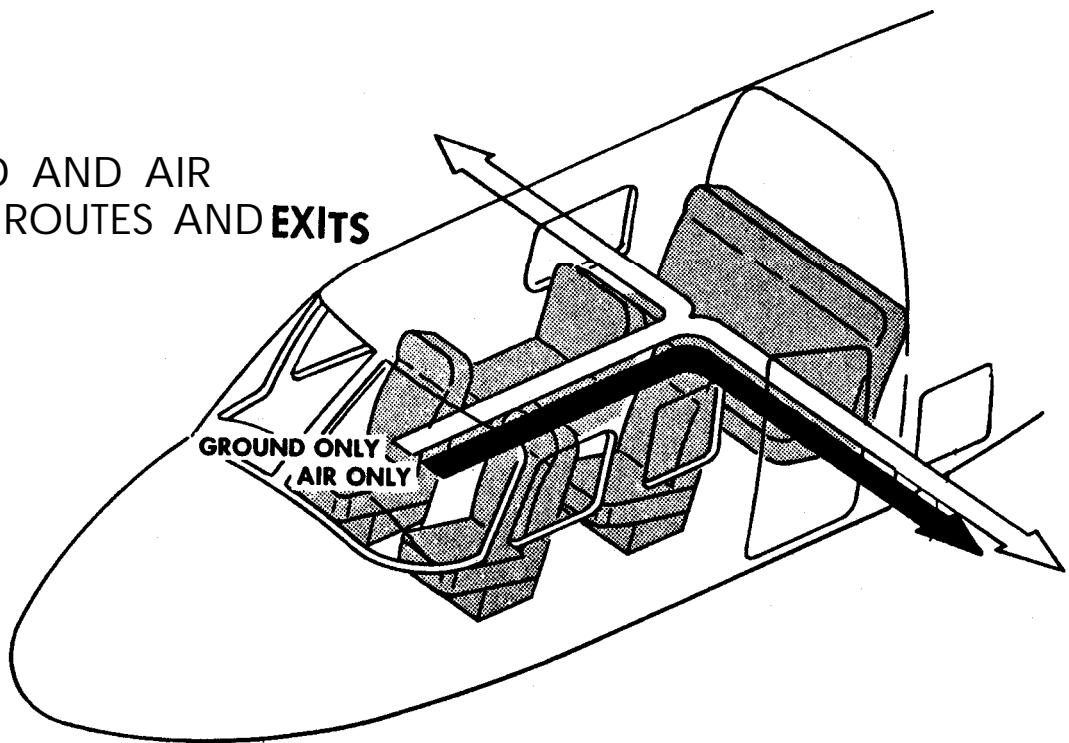

## EMERGENCY ENTRANCE

WINDSHIELDS OR WINDOWS MAY BE BROKEN IF ENTRANCE TO THE CABIN IS NOT POSSIBLE THROUGH THE DOORS.

Figure 5-40. Models U-9B, U-9C, and RU-9D aircraft—Continued.



GENERAL DESCRIPTION

TYPE - SINGLE ENGINE, LIAISON AND LIGHT CARGO, STOL  
 CREW - 2  
 PASSENGERS - 3

(MODEL U-10A DOES NOT HAVE THE RIGHT AND LEFT OUTBOARD AUXILIARY FUEL TANKS)

DIMENSIONS (MAX) AND WEIGHT (GROSS)

LENGTH - 30 FT, 8.4 IN  
 WIDTH - 39 FT  
 HEIGHT - 8 FT, 9.6 IN  
 WEIGHT - 3000 LB

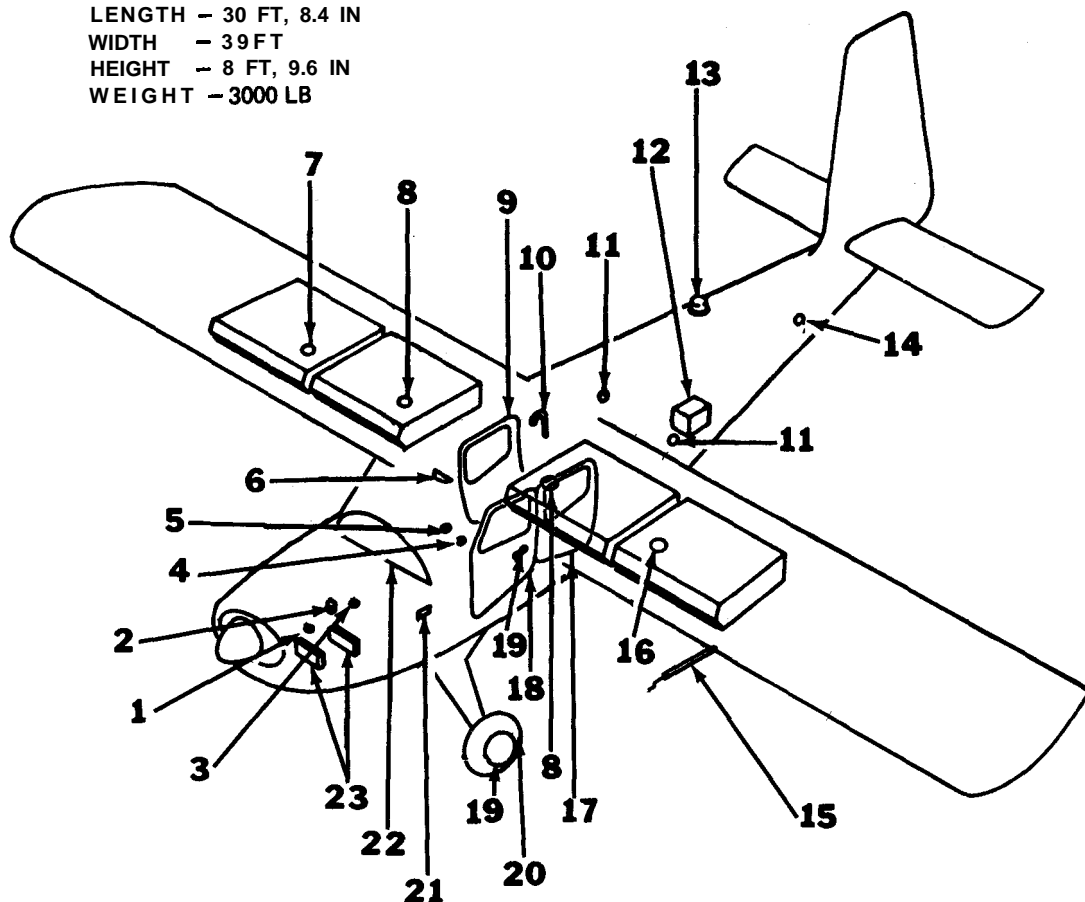

- |                                    |                                    |
|------------------------------------|------------------------------------|
| 1. OIL DRAIN                       | 13. ANTI-COLLISION LIGHT           |
| 2. OIL FILLER CAP                  | 14. RETRACTABLE LIFT HANDLE        |
| 3. FUEL DRAIN TUBES                | 15. PITOT TUBE                     |
| 4. STRAINER DRAIN (AUX TANKS)      | 16. LEFT AUXILIARY FUEL FILLER CAP |
| 5. STRAINER DRAIN (MAINTANKS)      | 17. LITTER DOOR PARA-DROP DOOR     |
| 6. TRIM TAB AND FLAP CONTROL PANEL | 18. PILOT COMPARTMENT DOOR         |
| 7. RIGHT AUXILIARY FUEL FILLER CAP | 19. RELIEF TUBE DRAIN              |
| 8. MAIN TANK FUEL FILLER CAPS      | 20. TIRE FILLER VALVE              |
| 9. PASSENGER COMPARTMENT DOOR      | 21. EXTERNAL POWER RECEPTACLE      |
| 10. FUEL VENT                      | 22. INSTRUMENT PANEL               |
| 11. STATIC PORTS                   | 23. INDUCTION AIR FILTERS          |
| 12. BATTERY                        |                                    |

Figure 5-41. Model U-10D aircraft.

## EMERGENCY PROCEDURES

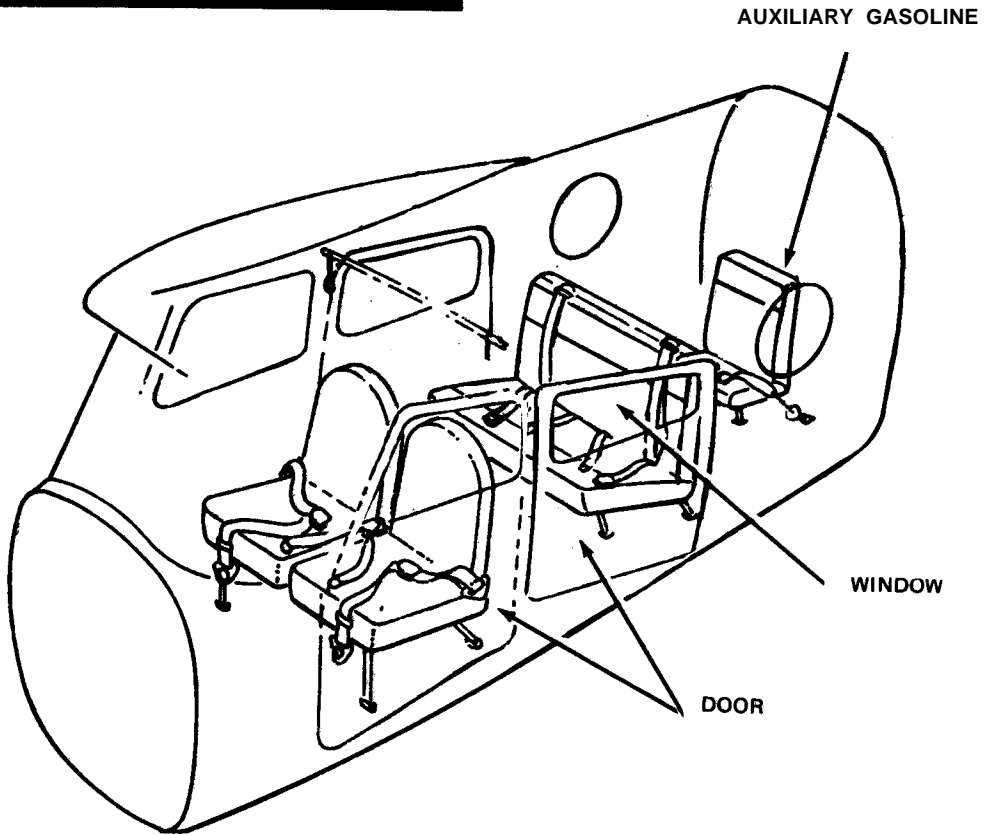

## EMERGENCY ENTRANCE

THE WINDSHIELD OR WINDOWS MAY BE BROKEN IF ENTRANCE TO THE CABIN CANNOT BE GAINED THROUGH ANY OF THE ACCESS DOORS.

Figure 5-41. Model U-10D aircraft—Continued.

GENERAL DESCRIPTION

TYPE **TWIN ENGINE, LIAISON AND CARGO**  
 CREW - 2  
 PASSENGERS - 6 (TROOPS-10, or 3 LITTER CASES AND 3 AMBULATORY PATIENTS)

DIMENSIONS (MAX) AND WEIGHT (GROSS)

LENGTH - 35 FT, 6 IN  
 WING SPAN - 45 FT, 10 1/2 IN  
 HEIGHT - 14 FT, 2 9/16 IN  
 WEIGHT - 9650 LB

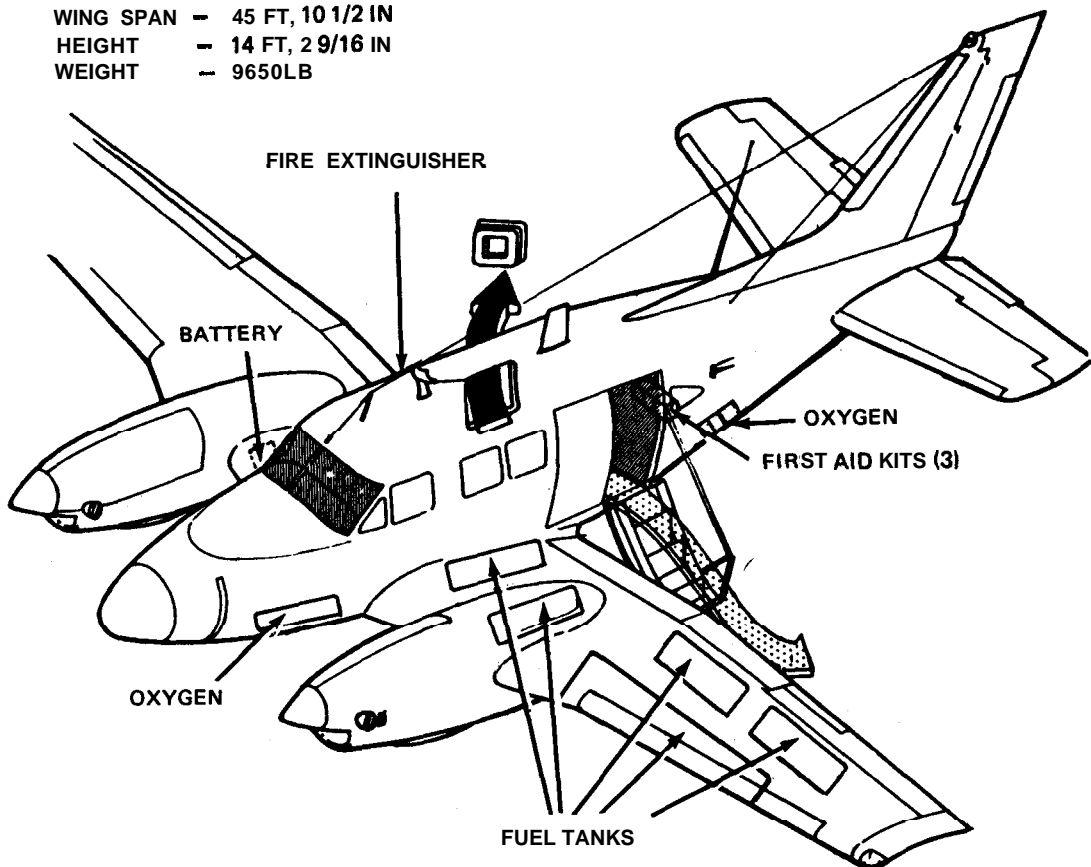

EMERGENCY EXITS AND EMERGENCY ENTRANCE



DITCHING AND GROUND EXIT ONLY



BAIL-OUT, DITCHING AND GROUND EXIT

**EMERGENCY ENTRANCE**

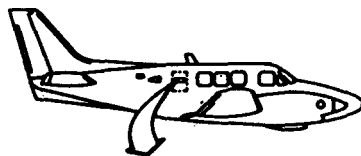

WINDOWS AND WINDSHIELDS MAY BE BROKEN IF ENTRANCE TO THE CABIN THROUGH THE DOORS IS NOT POSSIBLE.

Figure 5-42. Model U-21 aircraft.

GENERAL DESCRIPTION

TYPE - TWIN ENGINE, LIAISON, PASSENGER, AND CARGO  
 CREW - 2  
 PASSENGERS - 5 (3 OR 5 SEATS)

DIMENSIONS (MAX) AND WEIGHT (GROSS)

LENGTH - 34 FT, 2 3/4 IN  
 SPAN - 47 FT, 6 3/4 IN  
 HEIGHT - 9 FT, 7 3/4 IN  
 WEIGHT - 6730 L6

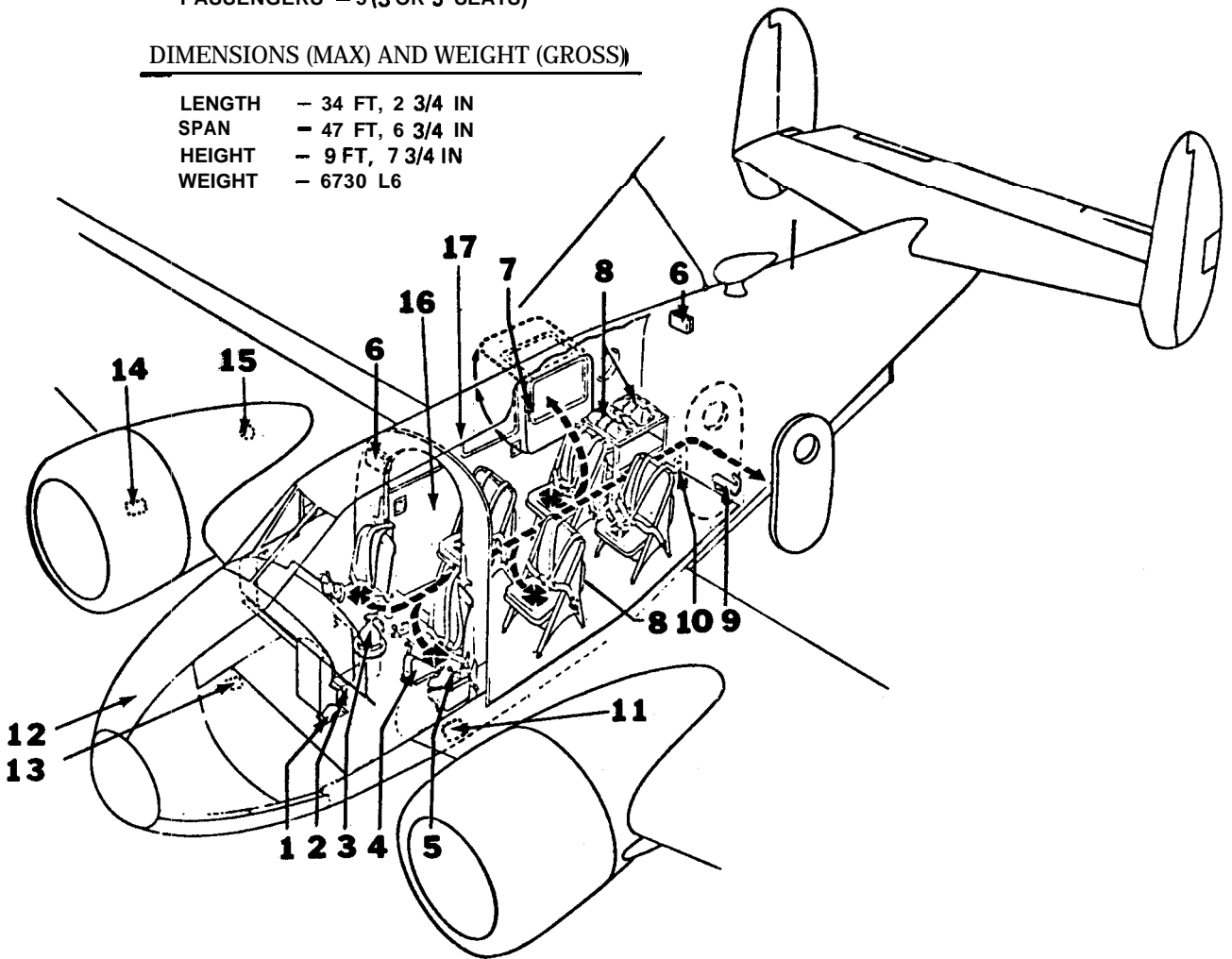

- |   |                                  |
|---|----------------------------------|
| 1. LANDING GEAR CLUTCH                            | 10. EMERGENCY DOOR RELEASE LEVER |
| 2. ENGINE FIRE EXTINGUISHER CONTROLS              | 11. BATTERY                      |
| 3. ENGINE FIRE EXTINGUISHER CO <sub>2</sub> 80TTL | 12. NOSE FUEL TANK (47 GAL)      |
| 4. LANDING GEAR AND WING FLAP HAND CRANK          | 13. BRAKE FLUID                  |
| 5. SHOULDER-HARNES LOCKS                          | 14. AUTO-PILOT RESERVOIR         |
| 6. FIRST AID KITS                                 | 15. OIL (8GAL)                   |
| 7. EMERGENCY ESCAPE PANEL RELEASE                 | 16. MAIN FUEL TANK (78 GAL)      |
| 8. PARACHUTES                                     | 17. AUXILIARY FUEL TANK (25 GAL) |
| 9. CO <sub>2</sub> HAND FIRE EXTINGUISHER         |                                  |

**EMERGENCY ENTRANCE**

WINDOWS AND WINDSHIELDS MAY BE BROKEN IF ENTRANCE TO THE CABIN THROUGH THE DOORS IS NOT POSSIBLE.

Figure 5-43. Model C-45 aircraft.

GENERAL DESCRIPTION

TYPE ---TWIN ENGINE, PASSENGER, CARGO, AND AMBULANCE  
 CREW - 6  
 PASSENGERS - 27 (FOLDING BENCHES1 AMBULANCE -15 TO 24 LITTERS

DIMENSIONS (MAX) AND WEIGHT (GROSS)

LENGTH -64 FT, 5 1/2 IN  
 SPAN - 95 FT  
 HEIGHT -16 FT  
 WEIGHT - 26,000LB

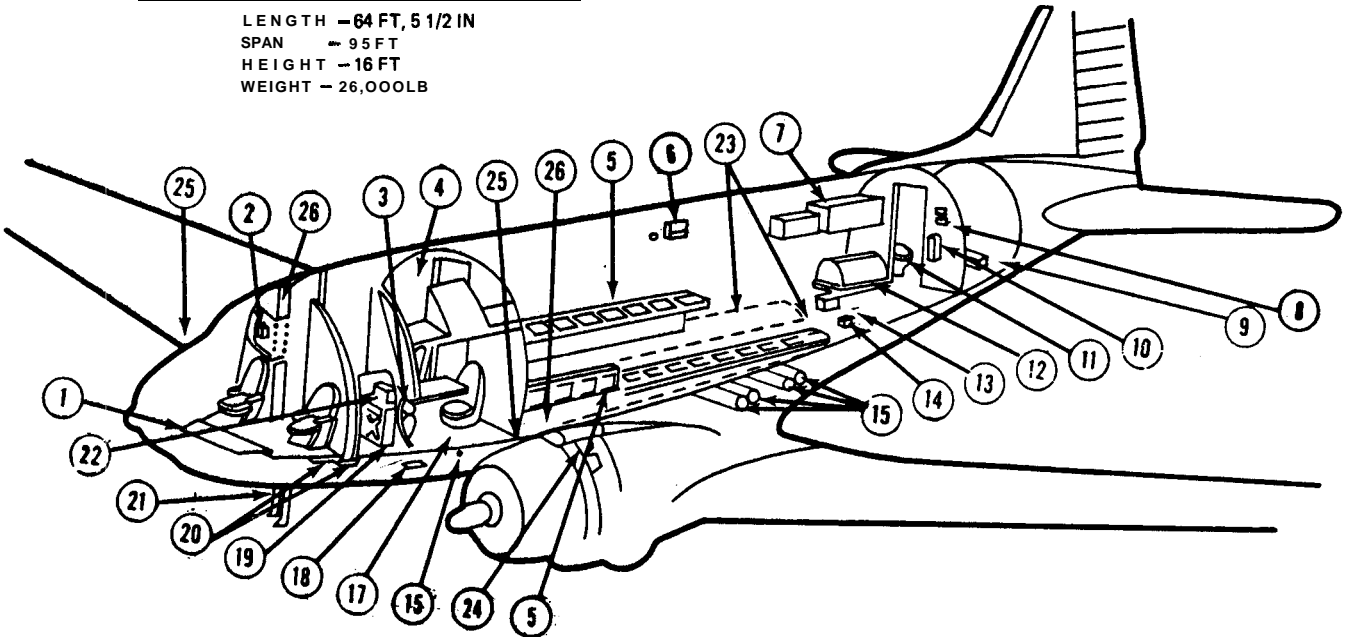

- 1. PILOTS COMPARTMENT
- 2. HYDRAULIC PRESSURE ACCUMULATOR
- 3. PORTABLE OXYGEN CYLINDER
- 4. RADIO OPERATOR'S COMP.
- 5. FOLDING TROOP SEATS
- 6. LITTER HANGER
- 7. SPACE HEATER
- 8. MISC. STOWAGE
- 9. ENG. COVER STOWAGE
- 10. SURFACE CONTROL LOCKS **STOWED**
- 11. TOILET
- 12. A. P. P.
- 13. PARAPACK CONTROL JUNCTION **BOX**

- 14. LOW PRES. SYS. OXY. FILLER VALVE
- 15. LOW PRES. SYS. OXY. TANKS
- 16. ALTERNATE STATICSOURCE
- 17. NAVIGATORS COMPARTMENT
- 18. EXTERNAL POWER RECEPTACLE
- 19. MAIN ELECTRICAL JUNCTION BOX
- 20. BATTERIES
- 21. PITOT STATIC TUBE
- 22. POWER SYSTEMS JUNCTION **BOX**
- 23. FUEL TANKS (LONGRANGE-285 GALLONSEACH)
- 24. C. B. CONTAINERS
- 25. MAIN FUEL TANK-m2 GALLONS EACH
- 26. AUXILIARY FUEL TANK-299 GALLONS EACH

Figure 5-44. Model C-47 (AF) aircraft.

ROUTES OF ESCAPE AND EMERGENCY EXITS

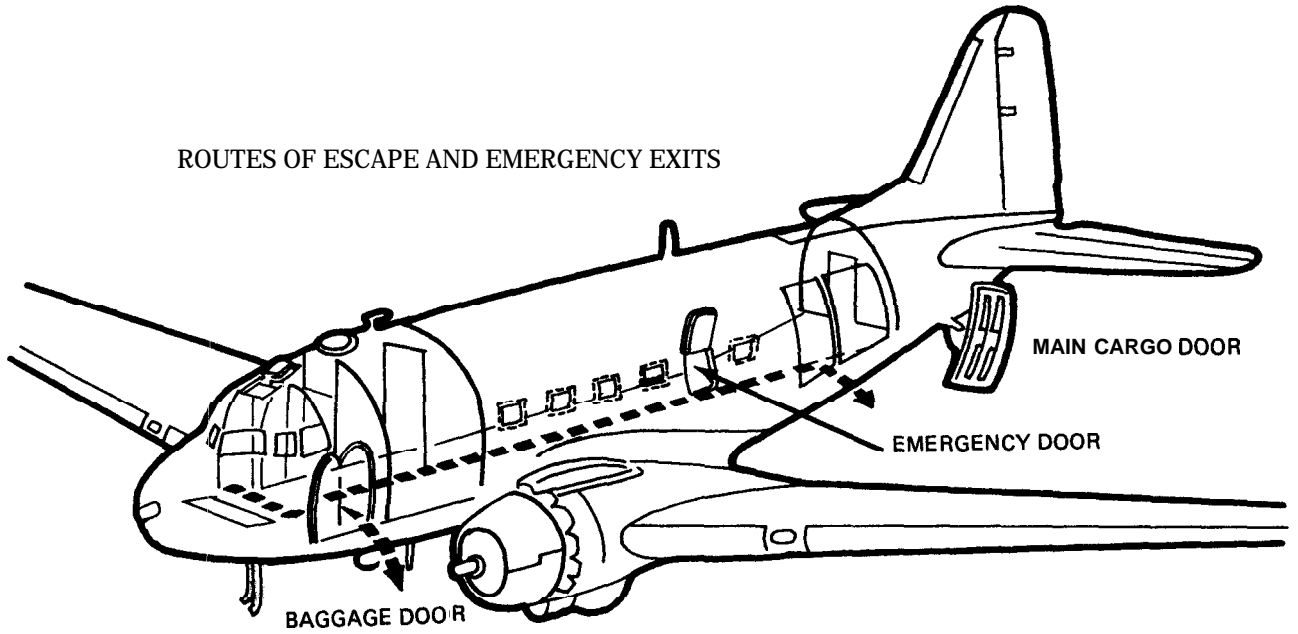

**EMERGENCY ENTRANCE**

(CUTTHROUGHAREASMARKEDINYELLOWONAIRCRAFT)

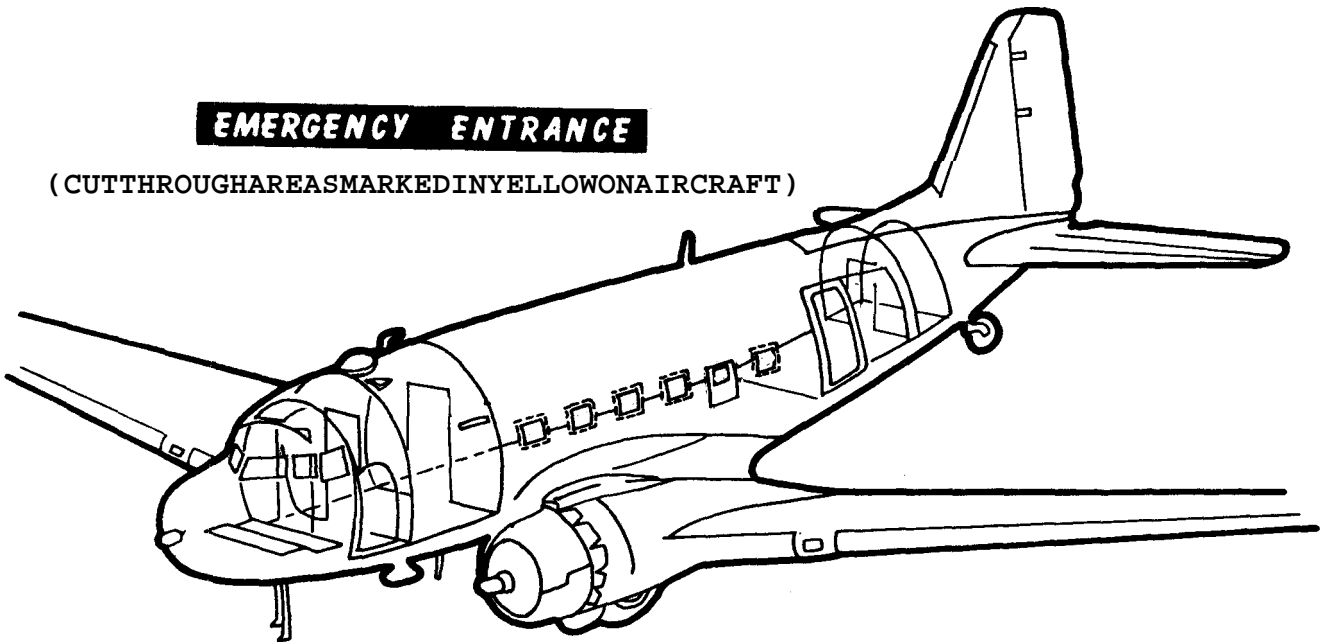

Figure 5-44. Model C-47 (AF) aircraft—Continued.

GENERAL DESCRIPTION

TYPE - TWIN ENGINE, CARGO  
 CREW - 2

DIMENSIONS (MAX) AND WEIGHT (GROSS)

LENGTH - 68 FT, 9 3/5 IN  
 WING SPAN - 96 FT  
 HEIGHT - 31 FT, 9 3/5 IN  
 WEIGHT - 26,000 LB (CV-2B-28500 LB)

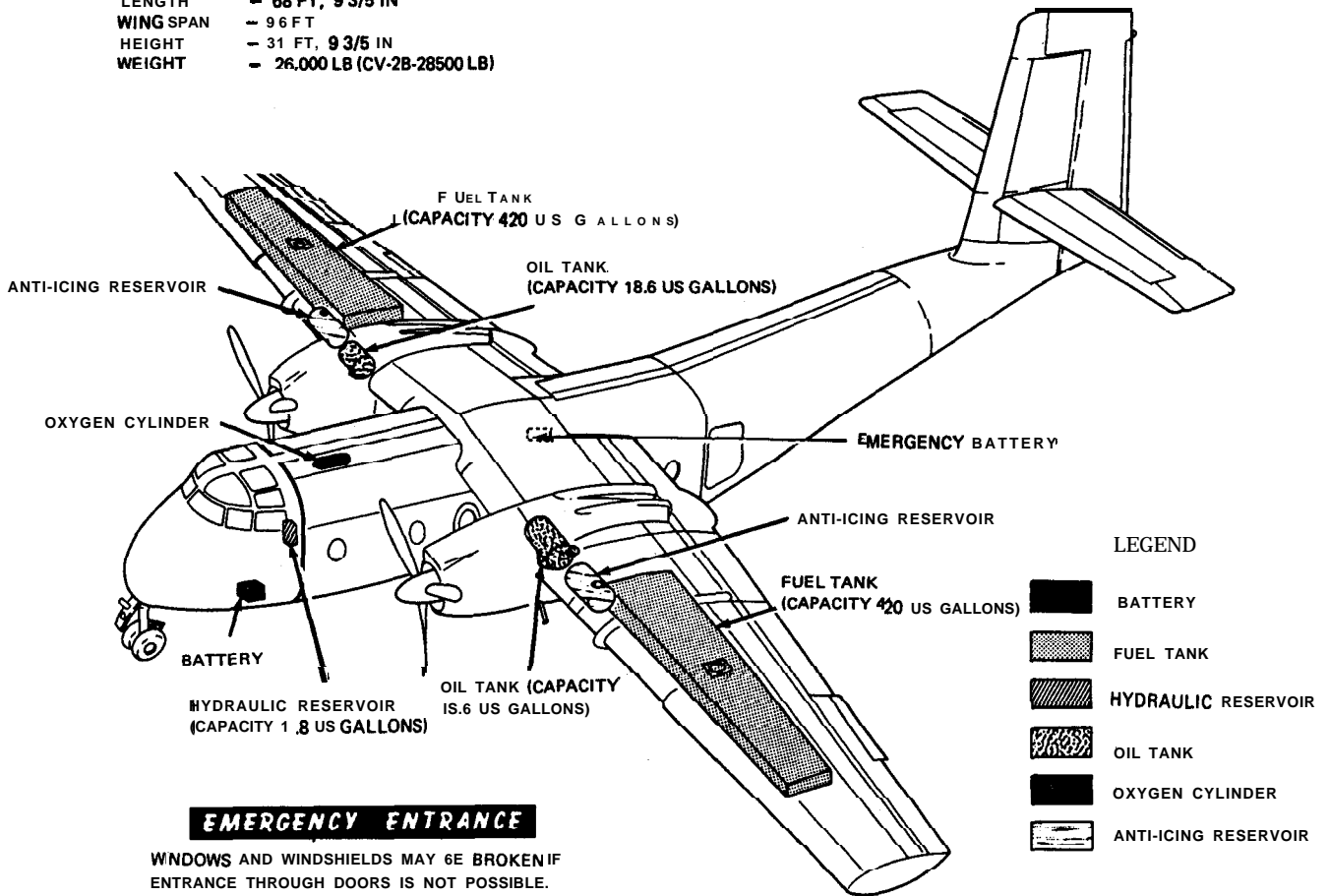

Figure 5-45. Models C-2A (AF) and CV-2B aircraft

GENERAL DESCRIPTION

TYPE - 4 ENGINE, PASSENGER AND CARGO  
 CREW - 4  
 PASSENGERS - 78

DIMENSIONS (MAX) AND WEIGHT (GROSS)

LENGTH - 95 FT  
 WIDTH - 132 FT, 7 IN  
 HEIGHT - 9 FT  
 W E I G H T - 134,000 LB (B)  
 175,000 L8 (H)

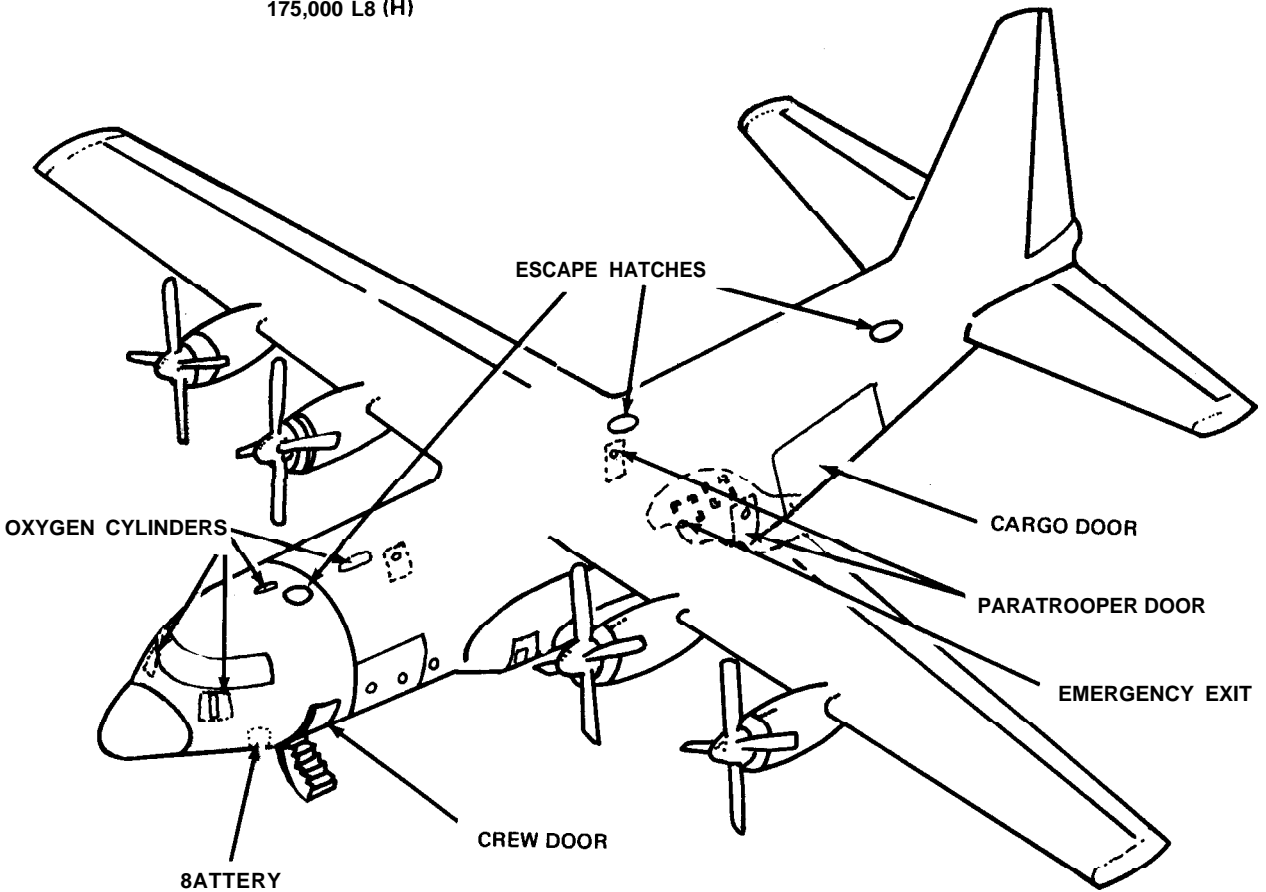

**EMERGENCY ENTRANCE**

THERE ARE FOUR ESCAPE HATCH RELEASES, INTERIOR AND EXTERIOR, ON TOP OF THE AIRCRAFT. ONE IS FORWARD OF THE VERTICAL STABILIZER; ONE AT THE TRAILING EDGE OF WING, AND THE OTHER TWO ARE FORWARD OF THE WING. THERE IS A PARATROOP DOOR HANDLE ON 80TH SIDES OF THE AIRCRAFT NEAR THE TRAILING EDGE OF THE WING. THERE ARE CHOPPING AREAS DESIGNED ON 80TH SIDES OF THE AIRCRAFT, THERE IS A CREW DOOR ON THE LEFT SIDE AT THE COCKPIT AREA.

Figure 5-46. Model C-130 aircraft.



**GENERAL DESCRIPTION**

TYPE - TWIN ENGINE, PASSENGER AND CARGO  
 CREW - 4  
 PASSENGERS - 60

**DIMENSIONS (MAX) AND WEIGHT (GROSS)**

LENGTH - 76 FT, 4 IN  
 WIDTH - 110 FT  
 HEIGHT - 34 FT, 6 IN  
 WEIGHT - 60,000 LB

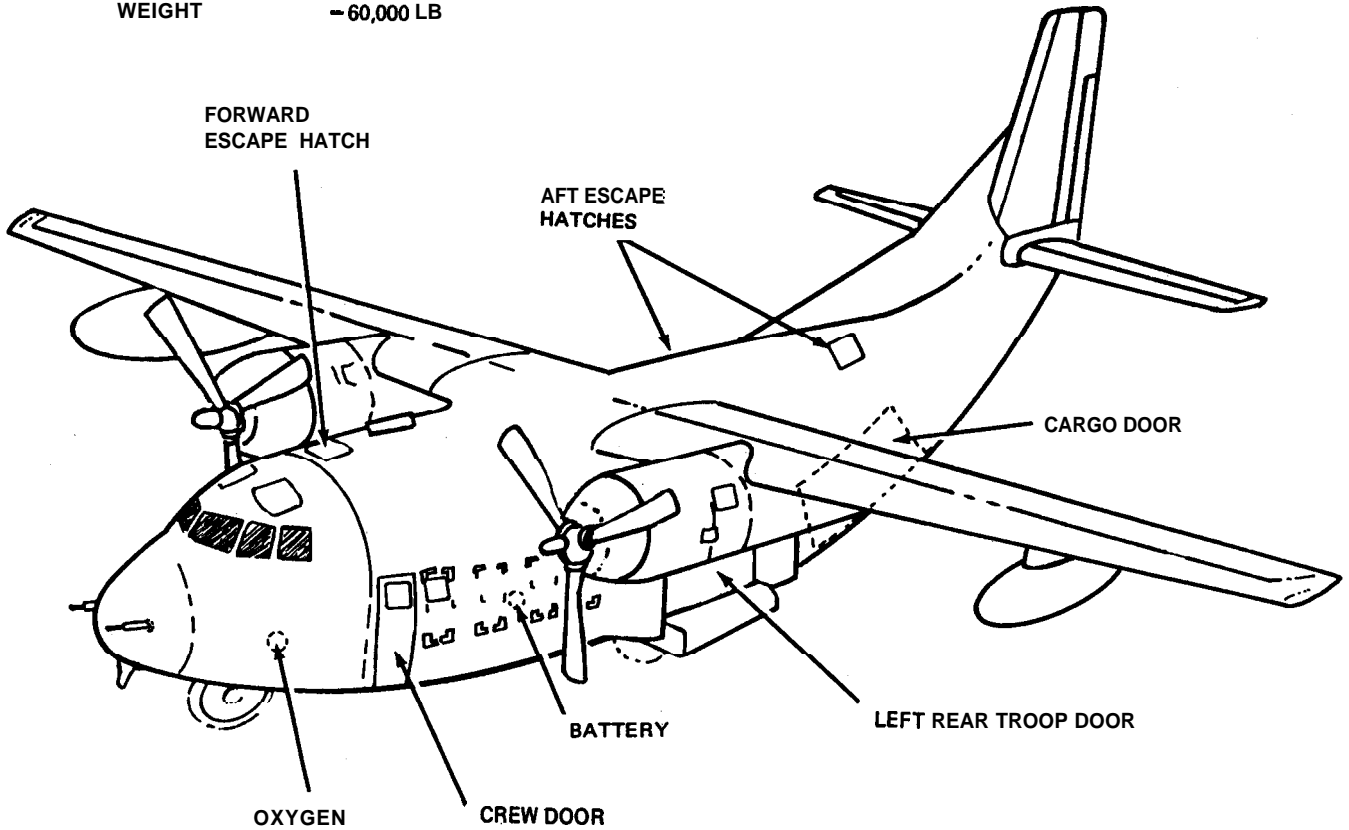

**EMERGENCY ENTRANCE**

EMERGENCY ENTRANCE MAY BE MADE THROUGH THE FORWARD ENTRANCE DOOR AND THROUGH THE TWO REAR TROOP DOORS. ALL THREE DOORS HAVE EXTERNAL CONTROL HANDLES AND ACCESS PANELS FOR REACHING EMERGENCY RELEASE HANDLES. EMERGENCY CUT-IN AREAS ARE MARKED AROUND ALL CARGO COMPARTMENT WINDOWS AND AROUND THE THREE DITCHING HATCHES IN THE CARGO COMPARTMENT CEILING. THE DITCHING HATCHES ALSO HAVE EXTERNAL RELEASE HANDLES FOR EMERGENCY ENTRANCE.

*Figure 5-47. Model C-123 aircraft.*

GENERAL DESCRIPTION

TYPE - TWIN ENGINE, PASSENGER  
 CREW - 3  
 PASSENGERS - 12 TO 44

DIMENSIONS (MAX) AND WEIGHT (GROSS)

LENGTH - 79 FT, 2 IN  
 WIDTH - 108 FT, 4 IN  
 HEIGHT - 28 FT, 1 84/100 IN  
 WEIGHT - 3500 LB

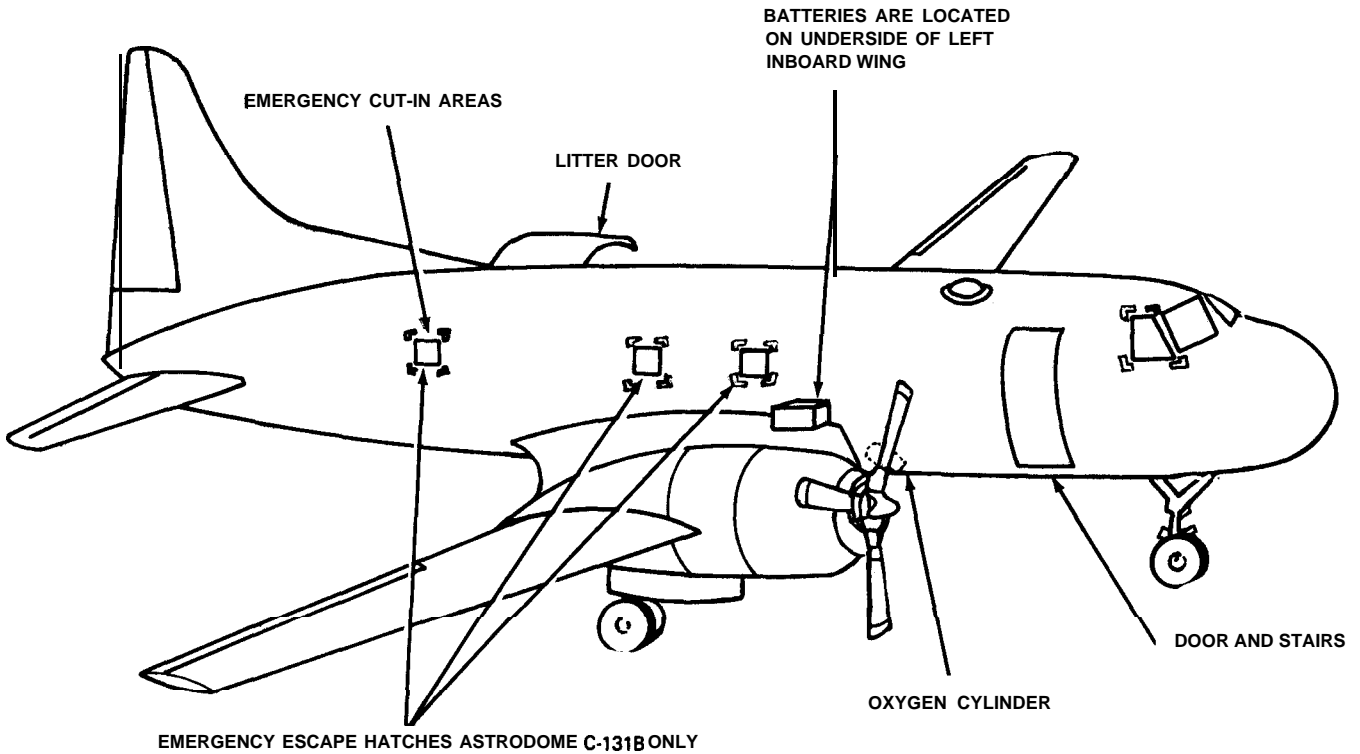

**EMERGENCY ENTRANCE**

EMERGENCY ENTRANCE MAY BE MADE THROUGH THE MAIN ENTRANCE DOOR AND EMERGENCY ESCAPE HATCHES. THE MAIN ENTRANCE DOOR IS ON THE RIGHT SIDE, AFT OF THE CREW COMPARTMENT. THE LITTER-LOADING DOOR IS HINGED AT THE TOP AND MAY BE OPENED BY ROTATING TWO LATCH HANDLES AND LIFTING THE DOOR. THIS ENTRANCE IS ON THE LEFT SIDE OF THE AIRCRAFT, AFT OF THE WING. EMERGENCY CUT-IN AREAS ARE MARKED ON THE AIRCRAFT FOR USE IF THE ABOVE METHODS OF ENTRY FAIL.

*Figure 5-48. Model C-131 aircraft.*

**GENERAL DESCRIPTION**

TYPE - TWIN ENGINE, OBSERVATION  
 CREW - 2

**DIMENSIONS AND WEIGHT (GROSS)**

LENGTH - 40 FT, 7.25 IN  
 WINGSPAN - 42 FT  
 HEIGHT - 13 FT, 4 IN  
 WEIGHT - 11,405 LB

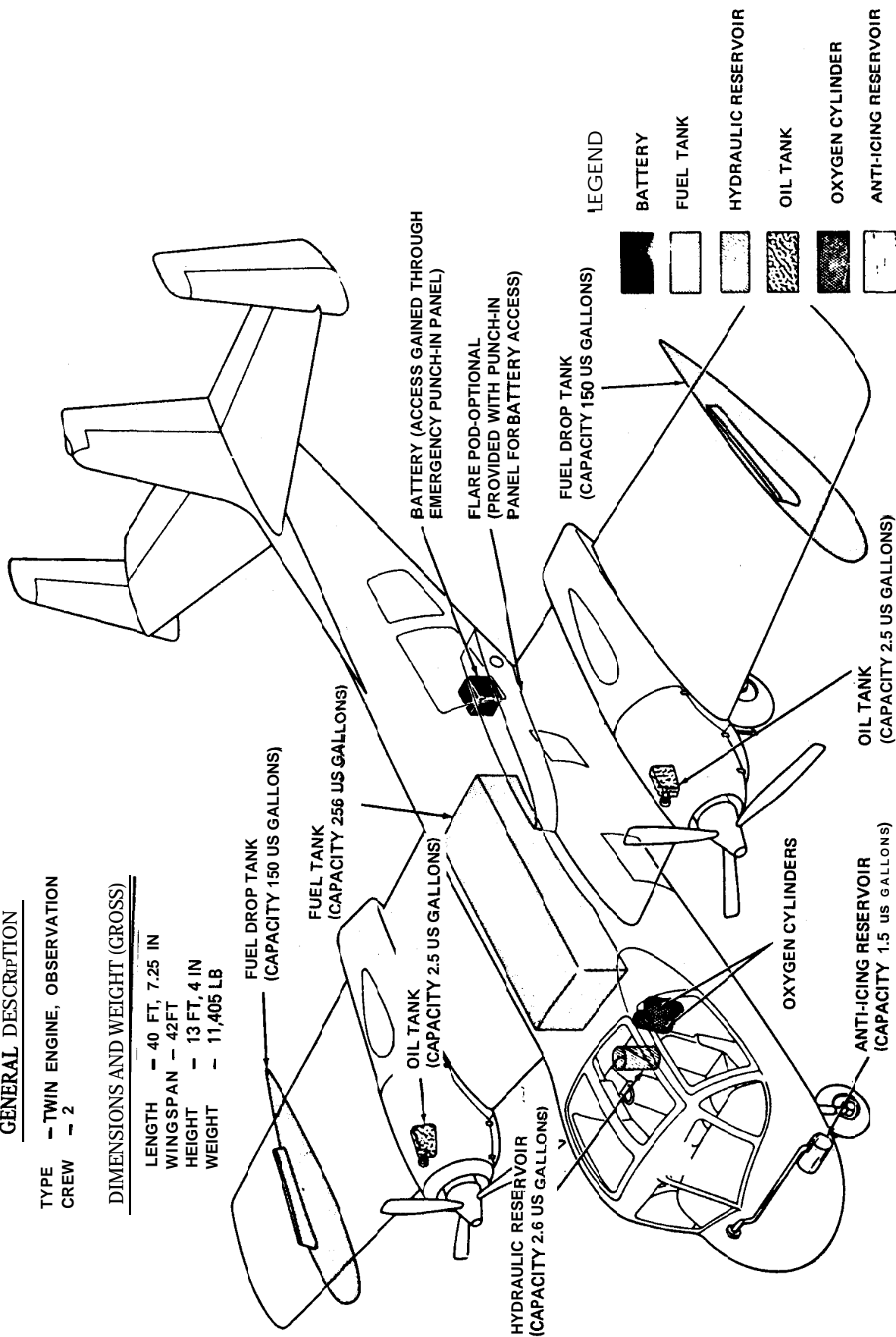

Figure 5-49. Models (with ejection seat) OV-1A, OV-1B, OV-1C, and OV-1D aircraft.

## EMERGENCY ENTRANCE

EMERGENCY ENTRANCE MAY BE GAINED FROM EITHER SIDE OF AIRCRAFT. LIFT EXIT RELEASE LOCK RING (DETAIL A) AND TURN TO UNLOCK POSITION. OPEN PILOT'S COMPARTMENT HATCH WITH LEVER BY PUSHING AT FORWARD END AND PICKING UP. IF EITHER HATCH FAILS TO OPEN, ENTRANCE MAY BE GAINED BY CUTTING THROUGH EITHER HATCH GLASS. IF ENGINES ARE STILL OPERATING, FLOOD AIR INTAKE WITH FOAM OR WATER. TO JETTISON EMERGENCY CANOPY, ROTATE EMERGENCY CANOPY JETTISON HANDLE (DETAIL B) CLOCKWISE 90 DEGREES AND PULL.

### CAUTION

MAKE SURE ALL PERSONNEL ARE CLEAR OF CANOPY AREA. CANOPY TRAJECTORY IS TOWARD AFT SECTION OF AIRCRAFT.

TIME PERMITTING, POSITION ENGINE MASTER SWITCHES, BATTERY SWITCH, AND OXYGEN REGULATOR SHUT-OFF LEVER TO OFF POSITION. ALSO PULL FIRE EMERGENCY CONTROL HANDLES.

## EMERGENCY PROCEDURES

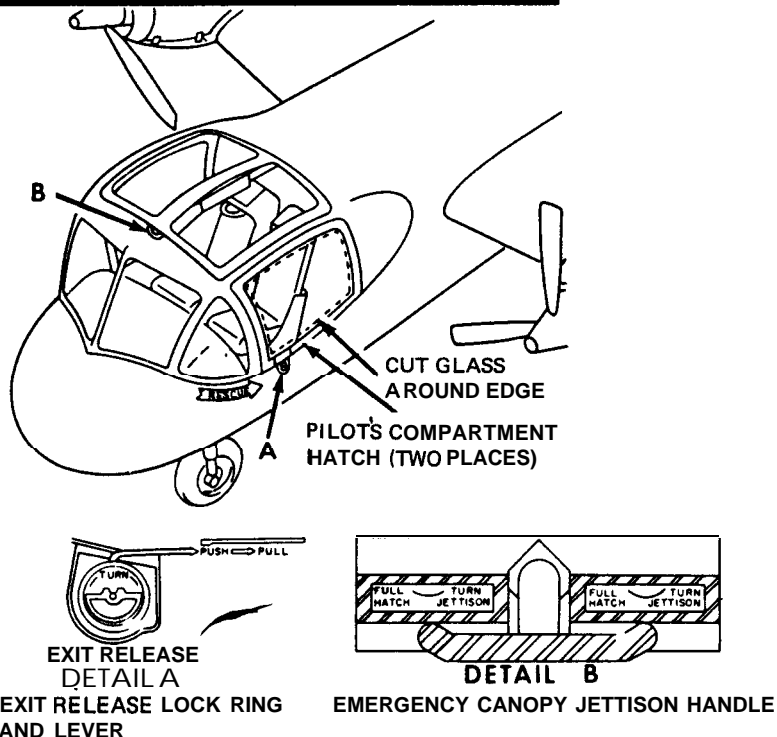

Figure 5-49. Models (with ejection seat) OV-1A, OV-1B, OV-1C, and OV-1D aircraft-Continued.

### SECURING THE EJECTION SEAT

1. Lift red tab of face blind (Detail C, fig. 5-49—cont'd (2)).
2. Lift lower firing handle safety guard (fig. 5-49—cont'd (2)).
3. Insert safety pins (2 of 5). First, the drogue gun pin (fig. 5-49—cont'd (2)), then the main ejection gun sear safety pin (Detail C). Emergency pins are in the map compartment of the aircraft, but must be carried in every crash vehicle for emergency use. A metal pin the diameter of a ten-penny nail can also be used.

### REMOVAL OF PILOT AND/OR OBSERVER

1. Unlock the harness quick-disconnect fitting by squeezing the release bar tabs and at the same time move the release bar upward. Then release the safety belt and remove the survival kit vertical restraint straps. Release the leg garters from the leg restraint cords at the quick-disconnects by squeezing the serrated lock release tabs to free the lock ring. Remove the pilot or observer through the pilot's compartment hatch or the emergency canopy opening.
2. If the harness quick-disconnect fittings and the lap belt cannot be unlocked, or if survival kit vertical restraint straps cannot be removed, the pilot and observer can be removed with parachute and survival kit attached by activating the manual override release lever. Raise up on the ring rearward until the handle locks. Next, unlock the harness quick-disconnect fittings by squeezing the release bar tabs and moving the release bar upward. Then unlock the lap belt and remove the survival kit vertical restraint straps. Remove the leg garters by squeezing the serrated lock release tabs which frees the lock ring.
3. Tilt pilot or observer forward from the waist and turn his shoulders toward the entrance hatch. Grasp the pilot or observer under his armpits, lift and pull him through the entrance hatch or escape hatch.
4. If there appears to be little chance of fire, it is advisable to leave the injured in their seats until qualified medical personnel arrive.

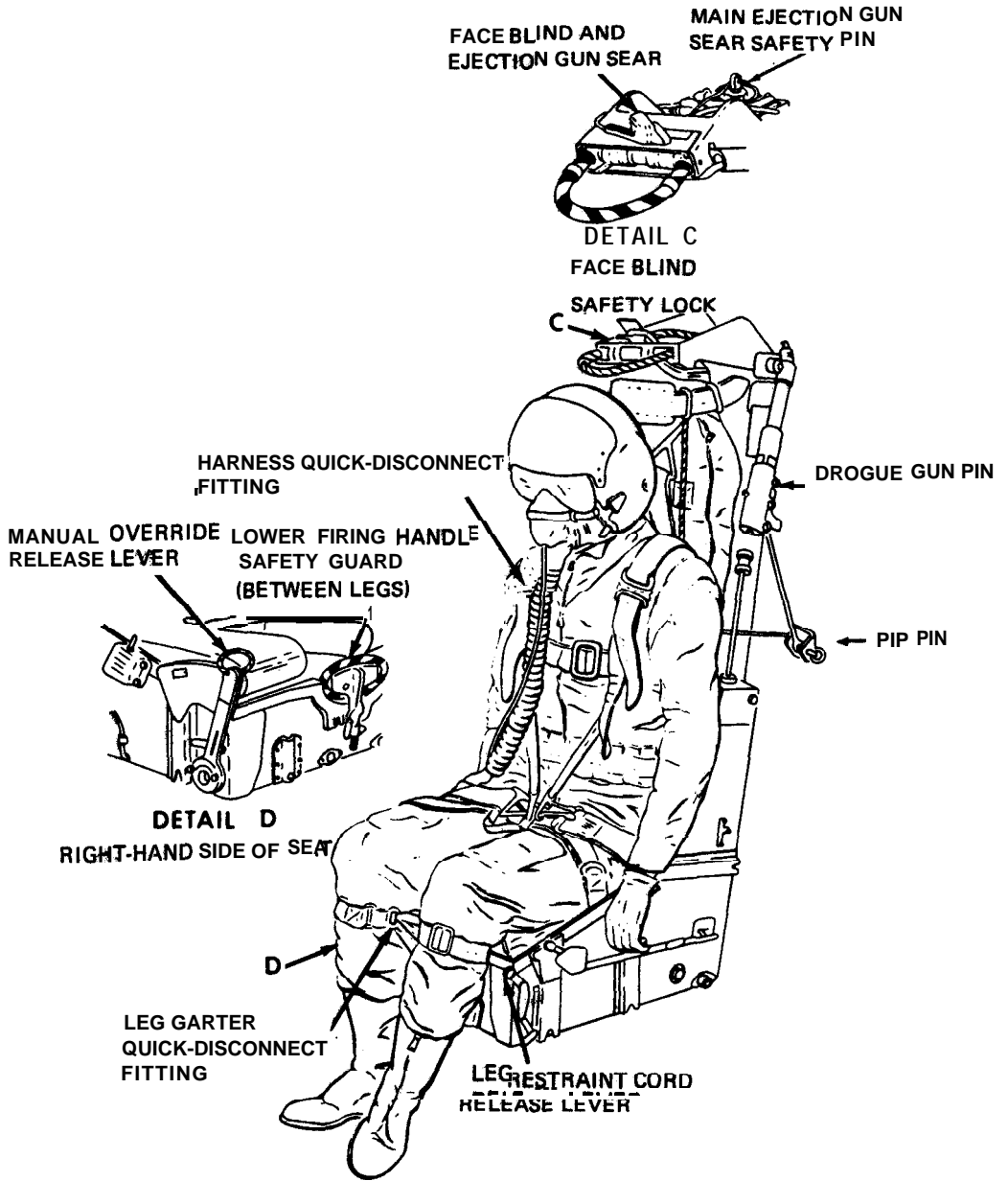

Figure 5-49. Models (with ejection seat) OV-1 A, OV-1B, OV-1C, and OV-1 D aircraft h-Continued.

## CHAPTER 6

## NUCLEAR WEAPONS FIREFIGHTING PROCEDURES

## Section I. GENERAL

6-1. Purpose and **Objective**

This chapter provides guidance to all individuals concerned with fires involving nuclear weapons and associated high explosives.

## 6-2. Policy

It is Department of the Army policy that fires in an area containing nuclear weapons will be fought until an explosion is imminent.

## Section II. RESPONSIBILITIES

## 6-3. Introduction

The prevention of accidents, including fires, is a responsibility of command. Commanders at every echelon are responsible for prevention of accidents involving personnel, operations, and activities under their jurisdiction. General areas of responsibilities, and policies and procedures to be followed for prompt, effective, and coordinated response to accidents and/or incidents involving nuclear weapons, are set forth in AR 50-2.

## 6-4. Commanders

Commanders responsible for the storage, handling, or transportation of **nuclear** weapons or nuclear materials will insure that

a. Personnel involved in the transportation, storage, or handling of nuclear weapons are familiar with the provisions of applicable nuclear accident information plans prepared in compliance with Department of the Army, USCONARC, and major **oversea** basic **policies**, with particular reference to guidance governing the release of **informaton** to the public regarding the presence of nuclear weapons or material at an accident scene.

b. Personnel working **inthe** vicinity of nuclear weapons are informed of and trained in proper fire-protection procedures.

c. Standing operating procedures are published and enforced, as required, concerning such matters as control and mvoement of nuclear weapons, positioning of firefighting equipment, exposure

control and evacuation of personnel in case of fire, reporting procedures required, and the like.

d. Civilian fire departments (municipal) which may be called upon to assist in extinguishing fires involving nuclear weapons are informed of the hazards involved and the procedures to be used,

## 6-5. Couriers

Nuclear weapons are classified items of material and as such must be safeguarded at all times.

a. Couriers are military personnel physically accompanying shipments of nuclear weapons material for security purposes. In effect, the courier "owns" the material; **i.e.**, he is the direct custodian of it. While he is physically able, it is the courier's responsibility to protect the material from loss or security compromise.

b. At the time of departure each courier is furnished information as to organizations which are to be contacted in event of an accident or incident. Couriers are capable of rendering technical advice pending the arrival of specially trained personnel.

6-6. Decontamination and Disposal **Teams**

a. Specially trained teams of personnel **respon-**sible for and equipped to detect radiation, to neutralize a weapon if necessary, and to decontaminate the area of explosives or nuclear materials, are maintained by the military services and by the Atomic Energy Commission.

b. Immediately upon notice to the military and

Atomic Energy Commission of an accident involving nuclear weapons, one or more of these teams, known as "Nuclear Emergency Teams," "**Explosive Ordnance Disposal (EOD) Detachments**," "Radiological Contamination (RADCON) Teams," "Alpha Teams" and "Radiological Emergency Medical Teams (REMT)", will be dispatched to the accident area.

### 6-7. The Nuclear Weapon— General Safety Factors

The extreme care devoted to the design of nuclear weapons and the equipment and procedures for handling them has been repaid with a record of no inadvertent or unintentional nuclear detonations. Because of the volume of weapons handled daily, accidents cannot be ruled out entirely. Because of the safety factors designed into the weapons, accidental detonation of the nuclear material is virtually impossible.

### 6-8. Explosion

In a typical nuclear weapon, high explosives surround the mass of nuclear material. The simultaneous explosion of the high explosives, timed in millionths of seconds, exerts even pressure inward on the subcritical mass of nuclear material and compresses it until it becomes supercritical, fissions, and sustains a chain reaction.

a. To become critical, the mass of nuclear material requires even compression by the surrounding high explosive. There can be no chain reaction until enough pressure is applied uniformly to sustain chain reaction.

b. To insure that the high explosive sends its pressure uniformly to all areas of the nuclear mass, a typical weapon has detonators arranged at many points, to be set off simultaneously by an electric charge. If the high explosive becomes accidentally ignited by fire at one point, it will burn or perhaps explode, but it will neither burn nor explode with sufficiently uniform pressure to make the mass critical. If the weapon should be inadvertently dropped, struck, or should accidentally fall from an aircraft, the blow may cause the ignition or explosion of the high explosive. Again, while any explosion would be at the one point which receives the blow or shock, this will not cause the nuclear material to become critical and sustain chain reaction.

### 6-9. Hazards

a. **General.** Even though nuclear weapons are so

designed as to prevent a nuclear yield in the event of accidental detonation, there is still a potential hazard commensurate with conventional weapons and materials. "The two components of a nuclear weapon which constitute the most probable hazard in case of an accident are—(1) the high explosive; and (2) the nuclear material. Other components may produce hazards, but they are of such nature that precautions taken against high explosive and nuclear materials are more than enough for their control. It should be kept in mind that accidents involving nuclear weapons or components usually will involve other materials in more widespread use, such as gasoline or other volatile and explosive fuels.

b. **High Explosives.** Most nuclear weapons contain high explosive. This high explosive comprises the major hazard associated with accidents involving nuclear weapons.

(1) **Identification.** Burning high explosives have certain characteristics which will enable the firefighters to recognize them. The high temperature at which they oxidize causes hot flame, or "torching," which is easily distinguishable from the flame of, for instance, burning petroleum fuels, or other materials. The smoke of burning explosive from nuclear weapons is noticeably light in color as it mingles with that from most other burning fuels.

(2) **Characteristic hazards.** As they burn, high explosives melt, flow, drip, spread, and mix with surrounding ground or wreckage. After the fire is extinguished these explosives are safe only if they are completely burned. **High explosives which have not completely burned remain an extreme explosive hazard.** After these explosives have cooled below ignition temperature they will, like metal, take on curious shapes. They may have picked up impurities, while molten or burning, which will make them actually more dangerous than they were before melting.

c. **Detonation.** In any accident involving a high explosive there is the possibility of a detonation occurring. The detonation may range from a very small one to one of considerable magnitude; or it may be a series of small explosions. The breakup of the weapon from impact or a small explosion will probably result in the local scattering of small pieces of high explosive. Rough handling, as well as accidents, may produce powdered explosives. Most high explosives are more sensitive in these conditions and are more apt to detonate when subjected to heat or impact or friction.



## 6-10. Nuclear Yield

The possibility of the accidental nuclear detonation of a nuclear weapon is so remote as to be negligible.

### 6-11. Nuclear Materials

a. **General.** As the result of impact or detonation of the high explosive, nuclear materials become dispersed as finely divided particles or, if a fire occurs, become dispersed as oxides. These particles, or oxides, are alpha emitters. Unlike the beta and gamma radiation in the fallout of a nuclear explosion, alpha radiation has a very short range and lacks the ability to pierce the skin.

b. **Body Effects.** Because of the inability of the alpha radiation to penetrate the skin, nuclear materials are not a hazard if they remain outside the body.,

(1) To avoid possible radiation effects and also the possibility of heavy-metals <poisoning (similar to lead poisoning), effort should be made to prevent nuclear material from entering the body.,

(2) When finely divided particles of nuclear materials, or their oxides, are suspended in the air, it is possible to swallow them or inhale them. Cuts in the skin provide another and more dangerous source of entry into the bloodstream.

c. **Intake.** Field experiments indicate that the principal source of intake of nuclear materials into the body is inhalation during the passage of the cloud resulting from the detonation or the burning of the nuclear material. Once the fine particles have been deposited on the ground, the hazard is markedly reduced. However, care should be taken that dust, which may have been contaminated, is not stirred up.

(1) It is always desirable to reduce to a minimum the intake of nuclear materials but, when necessary, one may enter or remain in a highly contaminated open area for short periods (up to several hours) after passage of the smoke cloud.

(2) Respirators, or preferably self-contained breathing apparatus, and protective clothing should be worn.

(3) Persons with cuts should remain outside the contaminated area(s).

(4) Under extreme emergency conditions, and in the absence of respirators or self-contained breathing apparatus, a wet handkerchief over the nose and mouth may be utilized to reduce the intake of nuclear material into the body.

### 6-12. Fire

If a nuclear weapon is enveloped in flame the high explosive may ignite, burn, and in many cases detonate. **Whenever heated or burning high explosives are confined, as in an intact weapon, detonation may occur at any time.** High explosives which have not completely burned may actually be more sensitive and dangerous than before being subjected to fire (para 6-9).

### 6-13. Fire Symbols: Explosive Symbols

a. **General.** To provide guidance to firefighting forces it is an accepted practice to divide explosives into four groups in accordance with the general burning and explosive characteristics of the materials and the relative danger in fighting fires in which they are present. The four groups are identified by symbol numbers 1 through 4. The hazard to firefighters increases progressively with the numbers. Nuclear weapons containing high explosives are included in the symbol 4 group (b below). However, it must be understood that the fire symbols were developed for conventional ammunition long before nuclear weapons came into being. Where nuclear weapons are concerned, categorizing the weapons on the same basis with conventional ammunition without due consideration of all the aspects of design, packaging sensitivity, and without regard for weapon vulnerability, would result in an unacceptable abandonment of the weapon to a fate where, in most instances, timely and intelligent application of firefighting techniques would and could prevent disaster. With conventional ammunition, a fire may involve various types of ammunition and explosives, each type varying in sensitivity and vulnerability to heat and flame. Packaging in most cases is highly flammable, thereby increasing the danger and rendering the firefighting effort more difficult.

b. **Symbol 4.** This includes materials which may detonate when involved in a fire. The safety of personnel in fighting a symbol 4 fire depends on the accuracy of the information made available to the firefighting forces. In case of rail or vehicle fires outside of the military installation, the transport vehicle will be labeled with "explosive" placards. All such vehicles with "explosive" placards will be regarded as symbol 4. For nuclear weapons involved in a fire, the minimum area to be cleared is 2000 feet (610 meters) (para 6-16b) in all directions of the fire.

### Section III. GENERAL FIREFIGHTING GUIDELINES

#### 6-14. Planning Prior to a Fire

The **potential** hazards surrounding a fire involving a nuclear weapon, and the protective measures which can be taken, vary widely. The time, during which a fire can be fought before detonation of the high explosive component becomes a possibility, will be critical in some cases. Therefore, it is important that situations in **which** a weapon may become involved in a fire be anticipated to the maximum extent feasible. Written plan of action or standing operating procedures should be prepared and should be familiar to all personnel who may become involved.

#### 6-15. Emergency Procedures

The first observer of the fire **should**—

a. *Assist.* Give immediate assistance to personnel where possible. However, except for the saving of lives, keep away from the fire. There is always the danger of a detonation of the high explosive component. Remain upwind and uphill from the fire. In saving lives, use any available method to prevent smoke from entering your eyes, nose, and throat.

b. *Report.* Report the fire immediately to the nearest fire department, whether military or municipal. Upon arrival at the scene, the police or fire department (military or municipal) should be asked to notify the nearest military **installation** or Atomic Energy Commission office (**para** 6-6).

#### 6-16. General Procedures

The techniques for fighting fires in which nuclear weapons are involved are basically the same as those used in fighting fires involving high explosives. The critical factor is the brief time available to extinguish or control the fire before the nuclear **weapon** is enveloped in flame. Therefore, teamwork and the quick application of current firefighting and operational procedures are vital to the successful fighting of such fires.

a. *Determination.* The primary consideration in determining whether to fight the fire is “How soon will an explosion occur?”

b. *Clearing the Area.* One of the first actions in any fire involving nuclear weapons is to clear the area of all personnel not actually needed or engaged in the **firefighting** operation. Where nuclear weapons are involved, the minimum clearance **dis-**

tance is 2000 feet (610 meters). Even at this **dis-** tance injury **from** flying objects is possible.

c. *Time Factor.* If the fire or impact does not immediately detonate the high explosive, the period of time available to fight the fire before such detonation might occur varies from a few minutes to an indefinite period, depending on the physical characteristics of the weapon casing and the intensity and proximity of the fire.

(1) When the weapon is enveloped in flame, or is subjected to high heat from conduction, convection, or radiant heat energy, the time factor is critical.

(2) When burning high **explosives** are confined, as in an intact weapon, *detonation of the high explosives may occur at any time.*

(3) When an intact weapon has become so heated that it cannot be touched with the bare hand it **is** vulnerable to detonation of the high explosive component.

(4) When an explosion is imminent all personnel will be cleared to at least 2000 feet (610 meters) from the fire. Personnel will not attempt to fight the fire.

(5) If the weapon is in an area adjacent to a fire but is not enveloped in flames, personnel should **attempt** to cool the weapon while extinguishing the fire.

d. *Safety Measures.* The standard firemen’s bunking clothing, **boots**, and helmet provide adequate shielding against the alpha **radiation** which may be present. Self-contained breathing apparatus **and** tight-fitting goggles should be worn if at all possible. The fact that some or all of these items are not available should not hold up operations necessary for rescue of personnel.

e. *Attacking The Fire.* If the decision is made to attack the fire, the senior fire department officer must make decisions rapidly. (If the available supply of water and other extinguishing agents is adequate, it may be possible to cool the weapon with a water fog and extinguish the main fire at the same time. If the water supply is such that both cooling and extinguishing operations cannot be accomplished, and it appears that this fire can be extinguished or controlled to a point at which heat absorbed by the weapon will not exceed safe limitations, it may be advantageous to use all available water on the fire **itself.**)

(1) Approach the fire from upwind and at a

maximum angle to any armament that might be **involved**. (For instance, since the heat of flames might fire them, do not approach directly into the line of guns, rockets, or missiles in the nose, tail or wings of a wrecked aircraft.) The approach should afford maximum effective application of extinguishing agents on the critical area and permit rapid withdrawal of men and equipment.

(2) The most important thing is to cool the high explosive and to secure control of fuel or other exposing fires quickly. If a weapon is located, cool its entire surface with the available extinguishing agent.

(3) Water is the most effective agent for cooling a weapon, or for extinguishing a fire **involving** high explosives. Application as a fog or spray is desirable. High pressure **application** can be dangerous; it can scatter exposed explosives, such as may be encountered with a damaged **weapon**.

(4) Foam in a wet mix may effectively be used to extinguish fires in explosives. Its disadvantage for this use is that it is not as good a cooling agent as water and it conceals the extinguished but still dangerous residue. This concealment increases the probability that the sensitive explosive will be stepped upon, and increases the difficulty of cleanup after the fire. The insulating quality of foam may be used effectively to shield a cool weapon from flame or heat. Because of its insulating quality, and reduced cooling effect, **foam, especially the protean type, will not be applied to a hot weapon if other agents are available**.

(5) High explosive materials have all the **ox-**

xygen necessary for combustion included in their chemical composition. Therefore, dry powder, **carbon dioxide (CO<sub>2</sub>)**, or other agents which extinguish fires by smothering or displacement of oxygen, are not effective in extinguishing fires in explosives. These extinguishing agents can, however, be used to gain control of fuel fires which, if permitted to continue burning, would involve the weapon.

(6) After initiation of **firefighting**, if evacuation of firefighting personnel is required, they will be withdrawn immediately upon order of the senior fire department officer. If **possible**, equipment will also be withdrawn. The minimum evacuation distance will be 1200 feet (366 meters) for firefighters and related support personnel.

#### **f. Action After Fire Extinguishment.**

(1) Immediately upon extinguishment of the fire all personnel will be withdrawn a minimum distance of 2000 feet (610 meters). The area in which the weapon is located will be kept clear of all personnel, other than the **specially** trained disposal and decontamination teams, until it is designated safe by the agency having such responsibility.

(2) When the fire **is** extinguished, personnel and all equipment that may have become contaminated from the smoke of a burning atomic weapon, will be congregated and isolated in an area at least 2000 feet (610 meters) from the weapon. This isolation is necessary to **prevent possible** contamination of others and will be maintained until release is authorized by specially trained and equipped monitoring and decontamination **personnel**.

## Section IV. FIRES INVOLVING NUCLEAR WEAPONS

### 6-17. Storage Fires

**a. General.** Weapon storage facilities will vary with geographical areas. Normally, storage of weapons will be in one of the following:

- (1) Underground magazine.
- (2) Earth-covered igloo magazine.
- (3) Outdoor storage.
- (4) Rudimentary storage.

**b. Fire Potentials.** Weapon storage locations are restricted in the use of flammable materials and flame-producing devices. Because of these restrictions and the high order of supervision and care **required**, fires seldom occur in weapon storage **fa-**

**ilities**. However, certain fire potentials may be present and should be considered, eliminated, or controlled. These potentials include building electrical systems ; fork lift trucks (electrical system, hydraulic system, or brake drums (overheated) ); storage hydraulic system (elevators) ; grass or woodland.

**c. Procedures.** When a fire occurs in a weapon storage location-

(1) Send someone to notify the **fire** department and other personnel as soon as possible.

(2) Apply portable firefighting equipment immediately, while the fire is in the incipient state, to extinguish the fire or control its **spread**.

(3) Remove power from electric circuits ; if and **when** indicated, remove fork lift trucks, and the like, to a **safe** area.

(4) Remove all weapons from the storage location to a safe distance from the fire when possible.

(5) **Techniques** and procedures used by the fire department upon its arrival will be in consonance with paragraphs 6-15 and **6-16**.

#### 6-18. Rail Fires

Rail shipment fires may occur at any point in the routing of the shipment: along the railroad, at railheads, at interchanges, or on a spur of the shipping or receiving installation. Procedures for dealing with rail fires require a rapid analysis of the situation. The following procedure will be taken :

a. Send someone to secure aid from motorized fire departments, if possible.

b. Immediately apply **portable** firefighting equipment.

c. Isolate the affected car from other cars.

d. Immediately inspect the interior of the car to see if the fire **has** penetrated inside and possibly ignited areas within the car.

e. If the fire or sparks **have penetrated** the floor or side of the car and the weapon is not enveloped in flame, fight the fire with any available **firefighting** equipment (water **is** preferable except for flammable liquid fires where foam is indicated).

f. Where size of the items, and conditions permit, remove the lading.

g. When an explosion is imminent, evacuate all personnel as provided in paragraph **6-16e** (6) and **6-16f**.

#### 6-19. Transport Vehicle Fires

a. **General.** Fires in **transport** vehicles may result from various causes. The most common causes of vehicle fires are electrical short circuits; collisions; overheated brakes ; overheated tires ; improper fueling techniques ; broken fuel lines ; careless smoking habits; and the like.

b. **Plan of Action.** Because of the varied situations or locations in which a transport vehicle may be involved in a fire, it **is** essential that the courier and transport driver have a mutually understood plan of action.

c. **Procedures and Techniques.** The following

will be considered in developing a plan of action for transport vehicle **fires**—

(1) Every effort must be made to prevent the detonation of the high explosive component of the weapon.

(2) Procedures and techniques (**para 6-15** and 6-16) may involve separation of a burning tractor from the van containing the weapon, the use of portable fire-extinguishing equipment pending arrival of the motorized fire department, and the unloading of the weapon from the vehicle.

(3) In some instances, such as a fire involving substantial spillage of flammable liquids or one involving liquefied petroleum fuels, and under other circumstances, it may be **evident** that there is no way of keeping the weapon cool enough to **avoid** detonation of the high explosive component. In **such** cases, the utmost effort must be directed toward the evacuation of all personnel from the area. On the open highway, immediate action will be taken to establish roadblocks at a safe distance. Minimum distance is 2000 feet (610 meters) ; preferably no less than three-fourths of a mile (1.2 kilometers).

#### 6-20. Tactical Vehicle Fires

a. **General.** Tactical vehicles transporting weapons will vary as to type, capacity, degree of protection provided by truck body, and facilities with **which** a weapon may be removed.

b. **Procedures and Techniques.** Fires involving tactical vehicles will vary in origin. Therefore, depending on the degree of seriousness of the fire, the location of the fire in relation to the weapon, and the potential for involvement of the weapon itself, varying techniques will need to be employed in combating the fire-or the situation may dictate evacuation of the area. Under some tactical circumstances extreme measures may be needed which ignore the **safety** of personnel required to fight the fire. The local commander will determine the action to take under emergency conditions.

( 1) In general, the principles and procedures prescribed in paragraphs 6-16 and **6-19** apply to fighting fires involving nuclear weapons in tactical vehicles.

(2) In some cases, the weapon in a tactical vehicle will be attached to a complete missile, with rocket in propulsive or nonpropulsive state. When fire involves the carrying vehicle or launcher, maximum effort will be directed to unloading the vehicle and isolating the complete weapon from

the fire. If this is not possible, the vehicle or launcher will be directed in such a manner that if the motor ignites the rocket will impinge on a solid earth mass such as a mound, **hill**, or other terrain so as to produce the least possible damage to life and property.

c. **Missile Fires.** Guidance for handling fires in complete missiles, carried on tactical vehicles or elsewhere, is given in paragraph 6-22.

## 6-21. Weapon Operation Fires

Fires near **weapons** being processed will vary in magnitude, source, and type.

a. **General.** Electrical fires are most likely to occur during electrical testing or electrical monitoring of the weapon. The fire may occur in a warhead section, in cables leading to the weapon, or in the test equipment. In any situation a sense of urgency and responsibility must prevail and tendency to panic must be overcome by imparting knowledge and skill through training and supervision.

b. **Procedures and Techniques.** The following will apply to all weapons not in shipping containers:

(1) **Emergency** firefighting equipment must be immediately used while the fire is in the incipient state. In every case effort **will** be made to bring motorized fire department equipment into play before the fire endangers the weapon.

(2) Weapon electrical fires must be dealt with rapidly and with a sense of urgency by knowledgeable and responsible personnel. Electrical fires in a weapons system **present** a serious condition which, if not immediately brought under control, may gravely affect the safety of personnel, the operation, and the facility or emplacement.

(3) One of the first steps in combating electrical fires will be the removal of power from the weapon or tester, whichever is applicable.

(4) If smoke or flames are emanating from the wiring within the weapon, use **CO<sub>2</sub>** (carbon dioxide) to extinguish any flames which may be present. The possibility of **flames** developing is **extremely** remote; smoke will be expected from overheated components and/or cables usually resulting from a short circuit. Since the smoke from some electrical apparatus may be toxic, necessary measures must be taken to prevent breathing toxic fumes.

## 6-22. Missile Fires (With or Without Warheads)

When flammable and explosive components for guided missiles and heavy rockets are properly stored by themselves, fire prevention precautions and fire-extinguishing procedures are not **complicated**. The proper type of extinguishing agent (e.g., water, foam, carbon dioxide, **dry chemical**) for each combustible component is indicated in missile training manuals or standard texts. However, when a missile is being placed in a "ready" condition, each phase of the assembly, fueling, and warheading places these flammable and **explosive** components close to each other. This completely changes the method and duration of the fire-extinguishing action, which is further complicated by the possibility that the recommended extinguishing agent for one component may not be correct for all other components involved.

a. **General.** The following firefighting guidance is general. The type, size, and design of the missiles in use preclude any attempt to establish firm policy and standards for fire-extinguishing methods and procedures which will be suitable for all types of missiles. Each commander of a missile unit must have a detailed fire plan, and every member of the unit must know what he must do in any given circumstance.

b. **Evacuation.** When a fire occurs, all personnel not essential for extinguishing operations or relocation of other missiles will evacuate the area at once.

c. **Inert Missile.** When an inert missile (i.e., unfueled without warhead, boosters, solid propellant motors, and other dangerous components) is involved in a fire, all types of extinguishing agents and appliances may be used in the area. (**Exception.** Straight water streams should not be directed against burning magnesium, if present, because a violent reaction and splattering of the molten metal will occur. Chemical extinguishers or water, while not effective on burning magnesium itself, may be used to extinguish adjacent fires and assist in reducing the temperature of the magnesium below its ignition point.)

d. **Partially Complete Missile.** When a partially or completely fueled liquid propellant missile, without warhead or boosters, is involved in a fire, the largest possible volume of water should be directed at the base of the fire; or foam should be used if flammable liquids are the burning fuel. If the **fire** is on the ground, every effort will be made

to prevent involvement of the missile by flushing the burning fuel away or relocating the missile. All personnel will evacuate the area as soon as any of the following conditions **exist**:

- (1) The surface of the missile starts to melt.
- (2) The brilliant white glow of burning magnesium can be seen.
- (3) It is readily apparent that complete **destruction** of the missile cannot be prevented.
- (4) The condition of the missile cannot be determined because of **smoke** and flames.

*e. Complete Missile.* Although a risk is assumed in fighting fire involving a fueled and warheaded missile, **aggressive** action should be taken if it appears that the fire may be extinguished or controlled to the extent that the missile will not be enveloped in flames. If the fire is on the ground, large volumes of water or foam **should** be used to flush any burning liquid away from the missile. If sufficient **waterflow** is available, a hose stream should be directed on the surface of the missile to

cool it; water should not be used for this purpose when the quantity of water available **would preclude** both cooling and extinguishing at the same time.

### 6-23. Aircraft Fires

The general procedure for fighting fire in an aircraft is the same whether nuclear weapons are carried or not. Rescue of personnel is primary and will proceed simultaneously with fire control measures as **determined** by the situation.

a. A **rapid** survey must be **made** of the aircraft to determine if the weapon is intact. If at all **possible**, a visual survey of the weapon within the aircraft will be made.

b. Knowledge of the weapon condition will aid in determining the—

- (1) Method of firefighting.
- (2) Time allowed to accomplish rescue operations **as** well as the firefighting.
- (3) Cooling techniques to be employed.

## CHAPTER 7

## MISCELLANEOUS FIRES

**7-1. Introduction**

There are many types of fires which, though related to structural or aircraft fires, may fall into a classification different enough to warrant the use of varied specialized agents and tactics. Broadly, these fires include ammunition and explosives, motor vehicles, and **natural-cover** fires. To combat these successfully, the **firefighter** will need a wealth of knowledge about each of these categories. This chapter discusses each type of fire to only a limited extent, but the **information** given will **provide** the firefighter enough background to become more efficient as he gains experience.

**7-2. Ammunition Hazards**

Ammunition fires are among the most feared because of their potential destructive possibilities by detonation. Where ammunition is involved, fire prevention is doubly important, since many of the fires involving explosives and ammunition are preventable. It is the duty of fire-protection personnel and personnel handling ammunition to study the causes of fire so they will know the safety precautions which must be taken to prevent fires,

a. **Heat.** A great hazard in an around **explosives** is heat.

(1) Some explosives ignite at temperatures substantially lower than those required to ignite wood, paper, or fabrics. The ignition of **explosives** frequently results in violent reactions. Every effort must be made to maintain normal temperatures around ammunition and **explosives**.

(2) Fires in ammunition dump areas may be due to a number of causes. The following are most **common**: dry grass, leaves, and underbrush ignited by sparks from locomotives, carelessly discarded cigarettes, campfires, or unprotected smokestacks.

b. **Deterioration.** Deterioration of explosives and ammunition normally occurs at such a slow rate that most of them remain serviceable **for**

many years. Under unfavorable conditions, explosives and ammunition which are deteriorating pick up heat so fast that it cannot be dissipated, and the explosives and ammunition may burst into flames as a result. An explosion or detonation may also result when deteriorating explosive or ammunition is confined too closely. A definite safety hazard results when repacking, renovation, and salvage operations are not **properly** supervised and conducted in accordance with recognized standards.

c. **Common Safety Violations.** Among the more common sources of fire hazards are excessive quantities of powder and loose explosives, accumulation of wastepaper, broken boxes, unauthorized use of spark-producing tools, defective machinery, faulty electrical equipment, and failure to **provide** the proper barricades and firebreaks necessary to prevent the spread of fire from one operation to another.

(1) Lack of training and violations of instructions or written regulations are frequently responsible for serious consequences. The most common violations include smoking, carrying matches in forbidden areas or buildings, and tampering with explosives or ammunition, **particularly** grenades or fuzes.

(2) Failure to understand and carefully observe the safety precautions prescribed for destroying ammunition and explosives might cause grass fires or explode nearby ammunition piles which are awaiting destruction. The most frequent **source** of these troubles is flying fragments released upon detonation.

d. **Sparks.** Sparks may be created by striking iron or steel nails or metal containers against iron or steel tools, or by nails in shoes striking flint, pebbles, sand grains, or nails in the floor. Such sparks, small as they are, have caused disastrous explosions of **black** powder and have exploded the dust from other easily ignited **powders**. This hazard is the **prime** reason for requiring tools of brass, copper, or other non-sparking materials. It

is recommended that mud or dirt be cleaned from shoes *before* entering magazines that contain exposed explosives. Also sparks from a faulty car or truck muffler may cause an explosion.

e. *Static Electricity.* Charges of static electricity can be accumulated on a person and on explosive material such as smokeless powder. The discharge of static electricity is a serious hazard in the presence of certain exposed explosives, dust and air mixtures, and flammable vapor-air mixtures. Processing equipment for such materials subject to static discharge should be electrically grounded, benches and flooring should be covered with electrically grounded conductive material, and personnel should be provided with safety shoes of an authorized type. Cushioned metal chairs should not be used in locations where explosives or highly flammable materials are present. The failure to control safely the use of heat and flame-producing equipment offers a constant hazard.

f. *Lightning.* Lightning may strike buildings, trees, or other objects in or near explosive areas. Buildings and structures in storage areas should have complete lightning protection where conditions permit.

g. *Transmission Lines.* Electric transmission lines are often blown down on or come in contact with combustible material. These lines should be periodically checked for condition and security of installation. When it is necessary to install power transmission and service lines in the vicinity of the buildings containing explosives, the distance from the lines to the buildings must be greater than the distance between the poles which support the lines. This precaution is necessary to prevent falling wires from coming in contact with the building. Overhead transmission lines must not pass within 50 feet (15 meters) of the building. In future installations power lines and services which enter buildings containing explosives must be placed underground within 50 feet (15 meters) of the building.

h. *Vegetation.* Vegetation (such as grass, undergrowth, weeds, etc.), which is or may become a fire hazard, should be controlled by using a chemical weed killer, by mowing, plowing, cutting, live-stock grazing, or, in calm weather and with the proper control, by burning.

(1) Chemical weed killers should not contain chlorates or other substances which may ignite spontaneously under hot, dry conditions or by friction.

(2) Burning should not be permitted within 50 feet (15 meters) of any earth-covered magazine containing explosives or ammunition, or within 200 feet (61 meters) of any above ground type magazine or outdoor storage pad. Brush, grass, wood, etc., gathered in piles, will not be burned within 200 feet (61 meters) of a magazine. Reserve supplies of dunnage, consisting of wood or other materials packed between explosives to prevent vibration or chafing, should not be stored haphazardly inside the magazine area. In no case may it be stored within the 50-foot (15-meter) firebreak around the magazine.

(3) A firebreak at least 50 feet (15 meters) wide and as free as practicable from flammable material will be constantly maintained around each aboveground magazine. The earth adjacent to and extending over igloo magazines should be cleared of dry debris. Firebreaks around the entire magazine area and at other locations within the magazine area, such as along railroad tracks, must be maintained whenever necessary.

i. *Trains.* Locomotives, trains, and other rail vehicles used in the magazine area must be equipped so that the communication of fire will be prevented as far as [practicable. Inspections should be made regularly to insure that safe conditions are maintained.

j. *Cleaning Fluids.* Gasoline or other highly flammable liquids should never be used for cleaning. Solvent, dry-cleaning (Federal Specification), must be used when cleaning solvents are required.

k. *Smoking.* Fire prevention regulations state that matches or other flame- or spark-producing devices are not permitted in any magazine or explosive area except by written authority of the commanding officer. Smoking is prohibited in any magazine or magazine area, or in the vicinity of cars, wagons, motor trucks, or boats in which there are explosives or ammunition. Buildings or locations for smoking may be designated outside restricted areas subject to certain limitations; smoking will not be allowed in locations closer than 60 feet (18 meters) to buildings containing explosives, ammunition, or other hazardous materials.

l. *Miscellaneous Hazards.*

(1) When buildings close to explosive or ammunition areas are approved for smoking, windows and doors must be fitted with wire screens.

(2) Suitable receptacles must be provided for cigarette and cigar butts and pipe ashes.



(3) Only permanently installed electric lighters of approved types may be used in the building.

(4) Portable fire extinguishers, sandboxes, and water barrels with buckets must be furnished as required for each room or building in which smoking is permitted.

(6) Persons wearing clothing contaminated with explosives or other hazardous materials will not be permitted in such areas.

(6) Automobile parking should be regulated so that vehicles will not be **parked** within **25** feet (7.7 meters) of fire hydrants and should use designated areas only.

(7) All flashlights or storage-battery lamps used in buildings containing explosives or flammable vapors must be safety-approved types for that specific type of exposure.

(8) Ordnance safety requirements must be complied with if **gasoline-** or electric-powered lift trucks are used for transporting ammunition or explosives.

### 7-3. Preventive Measures

Occasional fires may reasonably be expected, no matter how careful personnel are with flammable materials. But, by following the principle that "an ounce of prevention is worth a pound of cure," the **number** of fires can be greatly reduced. Below is a brief discussion of some of the measures that can be taken.

a. **Stacking.** Ammunition boxes, containers, **dunnage**, and lumber must be stacked in an orderly manner when in the vicinity of **explosives-** handling or storage operations. Stacks of such combustible materials must be limited to small areas between firebreaks. Additional factors to consider in limiting the spread of **fire** are the available space for combustibles, the availability of fire-extinguishing facilities, and the probability of fire. Under average conditions, areas under solid stacks of such materials should be limited to 1,500 square feet (139 square meters), separated from other similar **areas** by **50-foot (15-meter)** firebreaks in which vegetation has been cut and controlled. Bulk stacks of such materials should not be located within 500 feet (152 meters) of magazines or other buildings containing high explosives. Working quantities, within feasible limits, may be stacked in the vicinity of explosive magazines but not closer than **50** feet (**15** meters). Water barrels and pails should be liberally **provided** in such areas for extinguishing beginning fires. Additional rules may be issued as the

commanding officer deems necessary to secure the fire protection local conditions demand.

b. **Portable Extinguishers.** A **fire** involving explosives or ammunition produces a conflagration (major fire) or explosion very quickly; therefore, means for attacking the first small blaze detected are vitally important.

(1) Immediate use must be made of portable extinguishers and other hand equipment. In addition to organized permanent facilities, barrels and buckets filled with water should be placed at each magazine. This type of fire protection, when properly maintained and utilized, may be extremely valuable in explosive storage areas having open storage pads or combustible storage magazines. During hot weather the barrel must be refilled frequently; in freezing weather calcium chloride or salt must be added. Buckets deteriorate rapidly unless they are frequently painted or protected from the weather. They may be blown about by windstorms if they are not securely fastened in place. Fastening devices must be easily releasable.

(2) Boxes and buckets filled with sand (with shovels located nearby) are useful in isolating, checking, or extinguishing beginning fires. To combat grass or forest fires in or near the magazine areas, an adequate supply of gunnysacks, brooms, rakes, hoes, or other similar equipment must be maintained at suitable locations. This equipment should be regularly inspected **and** protected against theft or unauthorized use.

(3) When explosives and ammunition are being handled, or work is being done in the immediate vicinity of such stores, two portable fire extinguishers of adequate size and rating must be ready for immediate use. It is not necessary that these extinguishers be located permanently in a magazine. Portable extinguishers must be placed in the most accessible location. Serious fires may be prevented by the prompt use of hand fire extinguishers. They are required primarily for use on beginning fires of inert combustibles, such as grass, grease, oil, **dunnage**, etc., which, if not extinguished, may reach explosives. Personnel other than the individual using the extinguisher should seek safety immediately and report the fire.

c. **Water Distribution System.** The water distribution system should be **protected** by sectional control valves so that damaged sections of the main can be cut off without impairing the operation of the remainder of the system. Water **mains** should not be located under railroads or roads used for transporting large quantities of **explo-**

sives or ammunition, because a detonation may break the main. When it is necessary to have water mains pass under railroads or roads, cars or trucks loaded with ammunition must not remain over these water mains longer than necessary for continuous travel. Suitable signs must be posted to indicate such a location. Water mains should be protected with cutoff valves on both sides of the railroad or road. Fire hydrants should be connected to a looped grid system to provide a supply from more than one direction.

*d. Fire-Protection Personnel.* The duties of firefighters, guards, military personnel, and others should be arranged so that an adequate firefighting force is available at all times.

(1) Fire drills and fire-prevention inspections should be carefully conducted to insure that firefighting forces understand their specific duties and that firefighting equipment functions dependably under actual working conditions.

(2) Fires that occur in buildings or magazines containing explosives vary in intensity and effect, depending on the material involved in the fire. Certain explosives may detonate or explode immediately on contact with a spark or flame or when subjected to frictional heat or concussion. Fire may or may not result from the detonation. Some explosive substances burn freely while others may explode while burning. Some substances develop such intense heat, as in the case of smokeless powder, that firefighting efforts are impossible. Firefighting forces should be well acquainted with the hazards and best methods of combating fires in all such materials under their protection.

(3) With certain rare exceptions, water is used as the firefighting medium. Generally speaking, for extinguishing explosive fires, large volumes of water spray or fog, produced by special nozzles with large range and volume capacities, prove more efficient than solid streams of water. Solid streams of water at higher pressures and great range should be used when consideration for the safety of firefighting personnel makes it impossible to approach the seat of the fire. Training programs should emphasize the importance of laying as many hose lines as practical in order to surround the fire completely and to extinguish it rapidly. When an explosion is imminent, firefighters must seek shelter or lie close to the ground when directing long-range water streams to the fire.

(4) Guards and watchmen should be instructed that when smoke is discovered coming from a closed magazine or when there is other evidence that the magazine is afire, the alarm must be given as quickly as possible. A single guard on duty will not enter the building, since he may become trapped and unable to give the alarm. If the fire is discovered in the grass or other combustible material surrounding the magazine, the alarm should be given immediately. The guard should then do all that is possible, using extinguishers, water from nearby water barrels, or grass firefighting tools, to extinguish or control the fire until firefighting forces arrive.

(5) When a workman or some other person discovers a fire where personnel are working and explosives are present, the personnel should be evacuated by a signal in accordance with prearranged plans. At least one responsible messenger should be dispatched in the direction from which the fire department is expected in order to inform them of the nature and extent of the fire. The officer in charge of firefighters must not permit the advance of his men to such a fire unless he has what he believes to be accurate information as to the existing conditions and concludes therefrom that he is justified in so doing.

(6) Firefighting forces should attack a grass fire vigorously and try to extinguish it even when it is burning in the vicinity of a magazine. If a fire has actually gained headway in a magazine, firefighting forces should either combat the fire or seek the nearest suitable protection, depending on the type of ammunition or explosives within the magazine.

#### NOTE

When a fire occurs in a locked magazine, no attempt will be made to enter the magazine or fight the fire. All personnel will evacuate the area to a safe distance.

#### 74. Kinds of Explosive Fires

To guide firefighting organizations, explosives are divided into four groups in accordance with the general burning or explosive characteristics of the materials and the relative danger in fighting fires in which they are present. The four groups are identified by the symbol numbers 1 through 4 (fig. 7-1); as the hazards to firefighters increase, a progressively larger number is used. Regulations

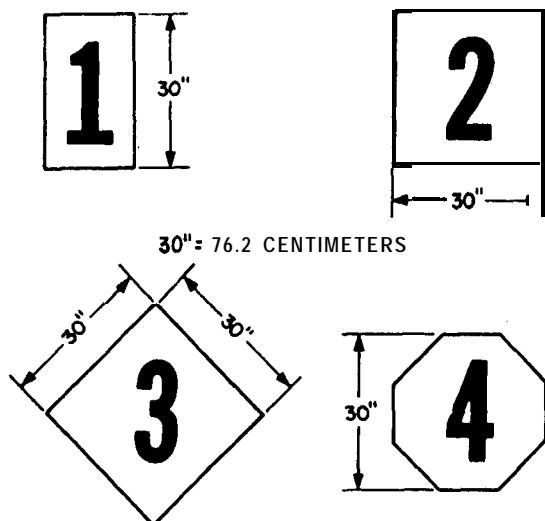

Figure 7-1. Hazard markers (fire symbols),

require that buildings containing hazardous or explosive materials, except igloo magazines, be plainly marked with the symbol number of the most hazardous material contained therein. These numbers must be at least 24 inches (61 centimeters) high, 20 inches (51 centimeters) wide, black lettering on yellow background.

a. **Ammunition Storage Chart.** In the early days of explosive manufacture, black powder was the only explosive used. Later, more sensitive explosives were manufactured. Still later, chemical ammunition came into use, and serious explosions occurred because of carelessness in handling. The ammunition storage chart was devised to standardize the handling of ammunition and to prevent accidents. This chart separates ammunition into the ammunition hazard classes shown below. These explosives and ammunitions must not be stored together in any random combination. They are mixed only under certain specific conditions which permit a maximum degree of safety.

Class 1—small-arms ammunition and similar items

Class 2—smokeless powder and other fire hazard items

Class 2A—items similar to Class 2, but presenting a detonation hazard

Class 3—point detonating fuzes and similar items

Class 4—small high-explosive (HE) cartridges and mines

Class 5—larger caliber HE cartridges

Class 6—separate loading HE projectiles

Class 7—mass-detonating high explosives

Class 8—chemical hazard without explosives

(1) **Symbol 1.** The symbol 1 group of explosives consists of class 1 ammunition.

(a) These are metallic powders in approved shipping containers—chlorates, perchlorates, peroxides, nitrates, and other inorganic oxidizing agents in sealed containers. While these materials are principally fire hazards, and fires in which they are involved may be combated, minor explosions may also be expected. Described below are some of the characteristics of fires in this group and the safety measures prescribed for them,

(b) Shipping containers of small-arms ammunition, especially when incendiary and tracer rounds are included, will continue to burn intensely even after the magazine has been consumed. Personnel attempting to fight the fire after it has reached the ammunition must be shielded from missiles, which may be expected to travel up to ZOO yards (183 meters) at a velocity of 200 feet (61 meters) per second. Sheet-metal-covered wooden shields can be used and moved to various vantage points. When it is practicable to use waterfog, it is found to be very effective for extinguishing such fires.

(c) Oxidizing agents are not flammable in themselves, but when heated in a fire involving combustibles they liberate oxygen, which greatly facilitates the burning. Suitable masks should be provided to guard against the poisonous fumes resulting from such fires. Cooling or “drowning” with large quantities of water may control or extinguish these fires. After the fire has gained considerable headway, firefighters must direct their efforts to protecting adjacent property.

(d) For fires involving chemical ammunition containing blister agents, firefighters must be protected by masks and complete protective clothing. If possible, such fires should be fought from the windward side. All unprotected personnel downwind must be evacuated and civilian inhabitants should be warned. Fires involving toxic chemicals should be fought with similar precautions except that the downwind area will be less hazardous. In fires involving hazardous chemical (H) smoke mixture, attempts should be made to remove and segregate the burning containers. When a relatively small amount of HC smoke mixture is involved in a fire, it may be saturated with water. Water will also serve to cool adjacent containers to prevent further propagation. Unless water can be applied in large amounts in relation to the actual HC smoke mixture exposed and burning, the efforts to light the fire will be inef-

fective, and the material may explode. Firefighters should not enter magazines containing a high concentration of HC smoke unless adequately protected by oxygen masks and supplied with lifelines.

(2) *Symbol 2.* The symbol 2 group consists of Class 3 ammunition and explosives. Personnel discovering such a fire **should** first give the alarm and then attempt to put the fire out with the equipment on hand, provided the fire is in the beginning stage. The firefighting organization should fight the fire if there is a possibility of extinguishing it. If extinguishment does not appear possible, the building should be abandoned and the firefighting efforts concentrated on preventing spreading. Limited explosions may be expected from fire in these materials. Personnel should be careful to prevent injury to themselves and damage to their equipment.

(3) *Symbol 3.* The symbol 3 group consists of Class 2 and Class 2A material.

(a) Unless the fire is minor and does not involve the explosive itself, and there is a chance of controlling it, firefighting should be confined to preventing the spread of the fire to other buildings. These materials burn with intense heat, and personnel and firefighting equipment should be adequately protected.

(b) When fires involve **phosphorus**, personnel entering magazines with portable extinguishers must have lifelines attached to themselves to enable them to find their way out through the heavy smoke. It should be remembered **that** phosphorus will stop burning only so long as it is under water; when exposed again to the air, it ignites **spontaneously**.

(c) Fires involving pyrotechnics and large quantities of magnesium type incendiaries make it necessary for firefighters to confine their efforts to protecting adjacent buildings and magazines. Water may accelerate burning and cause **explosions** which will scatter burning material. The use of carbon dioxide may cause a suffocating atmosphere. Small fires involving 50 pounds (22.7 kilograms) or less of magnesium can be smothered with dry inert material, powdered or granular, such as hard coal, tar, pitch, graphite (preferably coated to eliminate dust), **rustfree** cast-iron borings, soft coal, talc, salt, or sand. **Asbestos**, sand, salt, and talc are not inert in magnesium fires, but may be used dry if the fire is small. The powder from these agents should be placed over the burning material to cover it at least 1 inch (2.54 centi-

meters) deep. It should not be disturbed until the magnesium has cooled, except when the fire is **on** a floor of flammable material. In this case, after the fire is covered, a **2-inch (5-centimeter)** layer of extinguishing powder should be placed on the floor beside the fire and the burning material raked onto the insulating layer and resmothered.

(4) *Symbol 4.* The symbol 4 group includes Classes 4, 5, 6, and 7 ammunition and explosives.

(a) Every effort should be made to prevent fire from reaching these classes of material, which are especially hazardous. If a fire occurs in a magazine containing these materials, personnel present should attempt to extinguish the fire with the equipment at hand, providing the fire has not actually reached the material and there is a favorable chance of extinguishment. If the fire appears **beyond** control, personnel must evacuate the magazine and take cover. If fire breaks out in a magazine containing high explosives, firefighting forces will not immediately approach the fire.

(b) Unless specific information is **available** (either from one who was present when the fire was discovered or from intimate knowledge of the construction of the building and location of the explosives) indicating that it is safe to approach the fire, firefighting forces will remain in a position 1,000 feet (305 meters) away from a fire involving up to 50,000 pounds (**22,680** kilograms) of high explosives until the explosions have occurred. A proportionally greater distance is required for larger amounts of high explosives (up to 2,000 feet (710 meters) for 100,000 pounds (45,360 kilograms) of high explosives). **Firefighting** forces and their equipment must not be exposed to unnecessary risk when these materials are involved. Demolition or general-purpose 'bombs and antitank mines can detonate en masse, and propelling charges may explode, producing heat capable of blistering the paint on buildings 500 feet (152.5 meters) away. Bulk high explosives packed in boxes will usually burn quietly but may also detonate. Black powder, photoflash bombs, smokeless powder in bulk, and unpacked propelling charges explode or flash so quickly that little time is left to do anything to save the magazine involved. In almost every instance, the efforts of firefighters will be confined to preventing fire from spreading to adjacent buildings or magazines.

*b. Summary of Explosive Fires.* Fire is, without question, the principal hazard in the storage of ammunition in the field.

(1) The fact that ammunition and explosives are capable of such violent destructive force when exposed to heat makes it extremely important for fire-protection personnel to become as completely familiar as possible with the characteristics of various explosives and ammunition when they are exposed to heat. The men in charge of firefighting crews should be well aware of the importance of the counsel of ordnance specialists before and during an emergency.

(2) The ammunition officer must be completely familiar with the local environment of the areas in which ammunition and explosives are stored. He should also know the characteristic reactions of materiel to fire. The opinion of the ammunition officer, therefore, before and during the combating of the fire, should be respected. If the order is given to remain at a safe distance in readiness to prevent further fire spread after detonations or to withdraw men during the combating of a fire in expectation of an explosion, the action should be taken immediately. Where ammunition and explosives are present and where these conditions exist, an ounce of prevention is worth a ton of extinguishment.

**7-5. Chemical Munitions Markers**

Hazard markers provide a guide for firefighters and other personnel by indicating the chemical group of stored chemicals. The markers are yellow disks with a diameter of 24 inches (61 centimeters). Figures 7-2 through 7-8 show the symbol for each of group A, B, C, D, and nerve agents. Each figure also states what the symbol indicates and the hazard of the chemical agent or the precaution to be taken.

**7-6. Motor Vehicle Fires**

Another type of firefighting is fire resulting from motor-vehicle accidents.

a. These accidents are responsible for many thousands of deaths annually. Many of these deaths and many serious injuries are caused by victims being trapped in wreckage that has caught fire. This danger is always present in the Army because of the large volume of motor-vehicle transportation required.

b. Of course, motor-vehicle accidents are often attributable only to negligence or recklessness,

*Yellow disk with 2 parallel black bands*

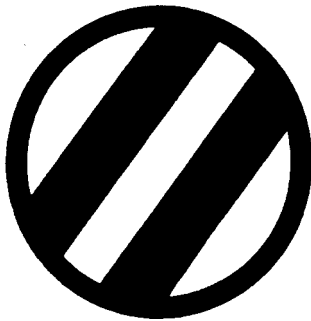

**INDICATES**

**Group A (except nerve agents).**

**PRECAUTION**

**Wear complete protective clothing and protective mask, Work upwind.**

*Figure 7-2. Hazard marker for group A.*

*Yellow disk with diagonal black band*

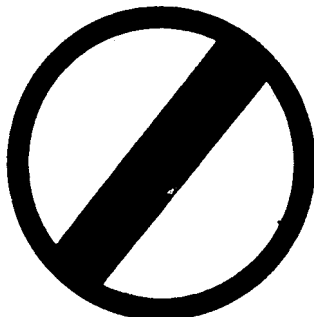

**INDICATES**

**Group B toxic chemical agents, nonburning screening smokes, and nonburning mixtures of riot control agents.**

**PRECAUTION**

**Use protective mask. Work upwind. Enter with care.**

*Figure 7-3. Hazard marker for group B (except BZ) .*

*Yellow disk with  
black letter Z*



**INDICATES**

**Special chemical hazard.  
Incapacitating agent BZ.**

**PRECAUTION**

**Use protective mask.  
Work upwind. Enter  
with care.**

*Figure 7-4. Hazard marker for agent BZ.*

*Yellow disk with  
black letter C*

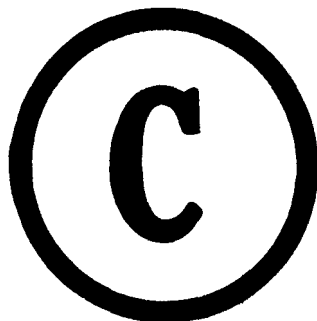

**INDICATES**

**Group C spontaneously flammable  
chemical agents.**

**HAZARD**

**Dangerous to enter without life-  
line and protective mask.**

*Figure 7-5. Hazard marked for group C.*

*Yellow disk with  
black letter D*

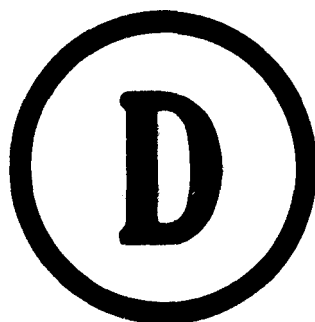

**INDICATES**

**Group D incendiary and readily  
flammable chemical agents.**

**HAZARD**

**Intense radiant heat. Danger of  
explosion if water is used to  
attempt to extinguish fire.**

*Figure 7-6. Hazard marker for group D.*

*Yellow disk with  
black letter G*



**INDICATES**

**Special chemical hazard.  
G-type nerve agents.**

**PRECAUTION**

**Wear complete protective clothing  
and protective mask. Do not enter  
until clearance is granted.**

*Figure 7-7. Hazard marker for G-type nerve agents.*

**Yellow dish with  
black letter V**

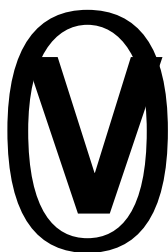

INDICATES

**Special chemical hazard.  
V-type nerve agents.**

PRECAUTION

**Wear complete protective  
clothing and protective  
mask. Do not enter until  
clearance is granted.**

*Figure 7-8. Hazard marker for V-type nerve agents.*

but when large numbers of personnel and quantities of materiel are transported under even the most favorable conditions, some mishaps are unavoidable. It is the duty and responsibility of fire-protection personnel to prevent loss of lives and property as a result of motor-vehicle accidents and, resulting fires.

*c.* When a motor vehicle overturns, or when it crashes into another vehicle or object, **trapping** the occupants inside it, assistance by experienced rescue personnel becomes an immediate necessity to prevent death by injury or fire.

*d.* Basically, motor-vehicle fire safety depends on **four** conditions: design and construction features ; use of the vehicle, including its garaging ; **proper** repair and maintenance ; and operational safety procedures.

*e.* The use of all-steel bodies has resulted in increased safety, both from the accident and the fire-hazard standpoint. Interior finishes, however, particularly upholstery and linings, still remain a definite fire hazard unless these **fabrics** are treated with a fire retardant.

*f.* The fuel-tank's construction, location, and security, and its vulnerability to damage in a collision or upset, are the most important **features** of design for fire safety. The use of seat tanks and cowl tanks has largely disappeared. Fuel tanks are safely located at the rear of, or beneath, the vehicle, in a position where they are not **inclosed** in the body. This positioning of the tanks gives passengers a better chance to escape if the auto catches fire. Trucks normally have tanks of **12-gage** steel, having high resistance to rupture. These tanks are of double thickness at the edges, will not spill fuel in an upset, contain an automatic pressure relief in the event of exposure to fire, will not seep gasoline, and cannot be over-

filled. Vibration, corrosion, and improper maintenance are some of the chief factors responsible for fuel-system failures, particularly at fuel-pump fittings, tubing, filters, and carburetors.

*g.* The fire safety factor in the electrical system of automobiles lies primarily in proper installation, fusing, and maintenance. Fires of an electrical origin are normally propagated by petroleum deposits in the engine area or by combustible materials, such as fabric lining. In a collision or upset, electrical short circuits are likely to occur unless an automatic overturn switch cuts the electrical power at the battery. Proper installation of exhaust systems is important, as incandescent carbon particles and hot exhaust gases may ignite flammable liquids, grease, and other combustible materials. Brakes are a possible fire hazard because their overheating may cause the ignition of oil, grease, or brake fluid. Friction heat frequently may **cause** underinflated tires to ignite. Anti-freeze-alcohol vapors are an added fire hazard, as are certain types of heaters.

*h.* In motor-vehicle fires, the first task is to evacuate all persons from the vehicle. If the fire is well advanced, fire-control operations may be necessary before they can be rescued. As soon as entry is made and personnel are removed from the vehicle, the ignition switch should be turned off, if this has not already been done. The battery should be disconnected (remove ground cable first) as soon as possible to prevent reignition of the already heated fuel vapors.

*i.* The average motor-vehicle fire can be quickly extinguished with portable **CO<sub>2</sub>**, **CF<sub>3</sub>Br**, or dry chemical extinguishers. When the engine area is involved in fire, the extinguishing agent can be applied through the louvers on grill. This permits extinguishing the fire without opening the hood.

Leaving the hood closed **limits** the oxygen and allows the extinguishing agent to **work** in a more confined area.

j. When the fire originates from a fuel tank leak, the fire closest to the tank should be extinguished first. The outlet in the tank then should be plugged to stop the flow of fuel. If the fire is in the upholstery, the area should be saturated thoroughly with water until every spark is eliminated. When a tire catches fire because of underinflation, large quantities of water are needed to extinguish the fire and prevent it from spreading.

k. The procedures in attacking a motor-vehicle fire will be described in proper sequence and detail in this and the following subparagraphs. The approach and general estimate of the fire must be considered first. Even as they approach the **vehicle**, the firefighters must be alert to protect or rescue personnel in or near the accident. Firefighters must be aware of the fact that victims with clothing on fire may **run** some distance from the scene of the fire. It is also possible that persons may be thrown from the wreckage and left unconscious near the scene where they are in danger of being run over by fire-department vehicles.

l. The primary consideration of the fire crew is to place the fire apparatus in a location which will enable the crew to give **occupants** the most complete protection and to control the fire so that personnel may be rescued with a minimum of delay.

m. The fire should be controlled first in the immediate area of the **vehicle** to relieve the occupants of excessive heat. No attempt should be made to extinguish the fire completely at the onset unless it is certain that no persons are still within the burning wreckage. Personnel rescue should be given priority because a **difference of seconds** may determine the life or death of a victim. Also, the extent of the fire may be too great for the quantity of extinguishing agents available in the firefighting apparatus to extinguish the fire completely.

n. When necessary, **forcible** entry must be made where it offers the most expedient access to the interior and is at the same time consistent with the location of trapped personnel within the vehicle. The person or persons closest to the point of entry should be rescued first. During rescue, the victims must be **examined** as thoroughly as time permits; the extent of injuries will be considered, and first aid will be administered *at once*. A visual check of the **victim** should be made before or **dur-**

ing rescue. If bleeding is profuse, direct pressure should be applied to the wound even before the **rescue** is completed. Rescued personnel should be moved to a safe spot quickly and carefully.

o. Firefighters must extinguish the flames in the area where the source of gasoline flow can be stopped. While cutting off the flow of gasoline, or while in the presence of gasoline vapors, the crewmen must always be alert for the signal which warns of the near depletion of extinguishing agents. This is a signal given by the pump operator for withdrawal of personnel. It consists of intermittent blasts from the fire vehicle. The pump operator is responsible for observing the **consumption** of the extinguishing agent.

p. After the gasoline supply has been shut off, the fire is immediately extinguished and the entire area is cooled **to prevent reignition**. The overhaul operation consists of entering the vehicle and thoroughly extinguishing every existent spark. If the fire was extinguished with **CF3Br**, the motor vehicle should be thoroughly ventilated before anybody enters it. The immediate area in which fire occurred also requires close observation, complete extinguishment, and reinspection.

q. During overhaul, each crewman should be alert for any evidence which will aid in the **investigation** to determine the cause of the fire. These "after-extinguishment" procedures require that a charged hose line be immediately available in the event of a sudden reflash.

## 7-7. Special Nozzles and Equipment

The majority of emergencies that the structural firefighter will have to face can be dealt **with** successfully by using the tools and **equipment** that have been explained in **previous** chapters of this manual. The fighting of special types of fires, such as those covered in this chapter, requires the use of specialized equipment, particularly nozzles.

a. *Fog Nozzle*. The ideal fog nozzle (**para 2-9a**) can discharge either fog or a straight blasting stream. After the high-velocity fog tip has been removed, it is possible to insert any one of several variable-length applicators containing a nozzle which discharges a low-velocity fog. This nozzle change will not require a change in nozzle pressure. Either the **high-** or low-velocity fog may be used for personnel protection or for extinguishing the fire, depending upon wind conditions and accessibility. Generally, the low-velocity fog is preferable when extinguishing a fire from the windward side and where large open surface



areas are involved. A leeward-side fire requires the use of high-velocity fog for personnel protection and penetration. Fog nozzles are made for use with both the **1½-inch (3.8-centimeter)** and **2½-inch (6.35-centimeter)** hose. The high-velocity fog tip and the low-velocity applicator may be inserted or detached in seconds.

b. *Foam Nozzle.* The mechanical foam nozzle consists of a metal base through which the venturi (cap v) system installed in an aspirator cage near the rear of the nozzle. A pickup tube is installed near the aspirator cage. The venturi system creates a partial vacuum, which enables the foam to pass through the tube from a foam can. The aspirator cage is responsible for injecting the proper amount of air into the proportionately mixed foam solution.

c. *Foam Generator.* The chemical foam generator consists of a metal base through which the water passes. The base includes a male and female coupling, normally **2½-inch (6.35-centimeter)** size; a venturi; a gage; and a valve. Mounted on top of the base center is the tapered metal hopper into which the powder is poured. The water passing through the venturi system "pulls" the powder into the water stream in the proper proportions, after which the powder and water are **turbulated** through 50 to 150 feet (**15 to 46 meters**) of **2½-inch (6.35-centimeter)** hose to the nozzle. When the water makes contact with the powder, a chemical reaction takes place which results in **expansion**, causing additional pressure and affording considerable range from the nozzle.

## 7-8. Natural Cover Fires

Natural-cover fires involve grass, weeds, grain, brush, forest, or any other plant life.

a. Forest fires are no doubt the most serious of all natural-cover fires from the standpoint of a national fire problem. Forest fires involve more than the immediate monetary loss. The cost is insignificant compared with the **effect** on the future water supply and timber supply, and with the loss of hunting, fishing, and recreational **facilities**, to say nothing of the loss of life which may occur. (A single forest fire in Minnesota is known to have taken 559 lives, a fact which emphasizes the importance of organized fire safety before such catastrophes occur.)

b. **Forest** fires frequently involve farms, villages, and towns. For this reason, fire-protection organizations are called upon to handle both

structural and natural-cover fires. During recent years, the nation has become increasingly conscious of the importance of the prevention and control of fires in camps and buildings, for these may expand to become forest fires.

c. The majority of natural-cover **fires** are caused by man and are the result of carelessness. The natural elements, such as lightning, the sun, and the wind, are responsible for the remainder. Careless hunter, campers, and fishermen, and frequently local residents, account for more fires than any other causes. Other causes of forest fires include locomotives, burning of rubbish, lumber operations, and arson. The most **effective** means of combating these fires should be started before the fire actually occurs—through the medium of law enforcement, restrictions, education, and the complete elimination of hazards in critical areas.

d. Prompt discovery of forest fires is essential in achieving quick control and limiting damage. In areas where efficient detection, control, and fire-extinguishing organizations are present, fires rarely get out of control and damage is kept to a minimum. The methods of detection include ground and air patrols and forest observation towers.

e. An adequate system of trails and roads, properly distributed, built, and maintained throughout the area, is of utmost importance in making the fire area reasonably accessible to **fire-fighting** forces and their equipment. Roads of proper width are also invaluable as firebreaks, which prevent the spread of fire beyond a limited area. In many instances, it is necessary to **clear-strips** for permanent firebreaks,

f. Aircraft of various types are now being successfully used to transport men and supplies to the scene of forest fires, especially such areas as may lack trails and roads. Parachute-jumping fire-fighters started extensive training before World War II, and have expanded and improved their effectiveness consistently during each succeeding year. In the years following the war, considerable **experimentation** and test flying was performed by the Air Force. The use of helicopters has been very effective. For forest-fire **extinguishing** by aircraft, the "water bomb" and other airborne devices are now being tested for effectiveness.

g. Training and organization are essential to suppress forest fires successfully. Under extensive emergency conditions, it is frequently necessary to use all able-bodied personnel within an area. At

such times, it is highly important to have **well-trained** men available to organize and supervise the untrained force. The complete and extensive training of fireguards and lookout men is of **utmost importance**.

*h.* The equipment used must be adequate and suited to the immediate environment. This implies, for example, that large vehicles will not be employed where roads are narrow and where there are small bridges with limited capacity. Areas where the water supply from ponds, lakes, and small streams is plentiful might advantageously **employ** several portable pumping units, but these units would be almost useless where water is scarce. In some areas, water cans equipped with a hand pump are carried on the backs of personnel. For fires in logging woods, water tanks mounted on pump-equipped trucks are commonly used, as are railroad tank cars.

#### 7-9. Tools

a. The common portable pump weighs about 75 pounds (35 kilograms). It is gasoline driven and can deliver 60 gallons of water per minute through a **1½-inch (3.8-centimeter)** hose at 100 pounds of pressure per square inch (7 kilograms per square centimeter). To attain this output, a **⅝-inch (1.6-centimeter)** nozzle tip should be used. The hose may be rubber lined, canvas **covered**, or it may be linen for lightness. Frequently, these portable pumps are hooked up in series to enable **propulsion of water** over great distances or up mountainsides.

b. Power-driven tools and equipment are available for natural-cover firefighting in a wide variety of designs and sizes. Power-driven equipment is used primarily for constructing barriers or **fire-breaks**. Such equipment varies from **100-pound (45-kilogram)** trenchers to **10-ton (g-metric ton)** tractors with front-mounted, power-controlled angle blades. These large tractors are better than all other equipment for **fireline** construction through heavy forests but costly equipment **is** required to move them to the desired location. Lightweight tractors are now being developed for fast initial attack.

#### 7-10. The Nature of Natural-Cover Fires

Natural-cover fires can move very rapidly, especially when the wind velocity is high. The perimeter, or fireline, is the hottest part of the fire. The interior of the **fire** is a **smoldering** mass with comparatively fewer flames and with many glowing

embers or sparks. Natural-cover fires are best controlled along the fireline.

#### *ct. Parts of the Fire.*

(1) The point where the **fireline** is **progressing** fastest is called the **head**. A natural-cover fire may have any number of heads, depending on the type, abundance, and location of the fuel. Fire heads generally travel with the wind; the stronger the wind, the greater the speed of the fire. **Because** of frequent directional changes of the wind, varying types and **quantities** of fuel, and topographic **conditions**, natural-cover fires have irregular perimeters, making control difficult and often dangerous. The upwind or windward **portion** of the fire is called the **tail**. Usually the tail is in or near the general vicinity of the origin of the fire.

(2) All portions of the **fireline** between the tail and the various heads and those slower burning areas between the heads are called **flanks**.

(3) The rate of burning of natural-cover fires depends primarily on the velocity of the wind, type and abundance of fuel, and general topographic conditions. The head of the fire travels at a rate proportional to the wind velocity. Wind carries additional oxygen to the fire and increases the rate of burning. The hot air rising from the fire causes a partial vacuum. Cold air with a fresh supply of oxygen rushes in at the base. The larger and hotter the fire, the stronger is this draft created by the fire.

(4) Fire heads move faster uphill and through **draws** or canyons than on level ground or downhill, other **conditions** remaining equal. Heads burning uphill dry out and **varporize** fuel faster than those burning on level ground or downhill. The upward rush of cold air acts like the draft in a chimney and speeds burning accordingly. Heads running up draws, valleys, or canyons cause the inrush of cold air with a new oxygen supply to be concentrated in a small area and, as a result, the fire propagation rate is greatly increased. This condition is similar to a forced draft in a blacksmith% forge, fanning the fire to a greater speed and intensity. Men or equipment should never approach the head of a fire from upwind when the approach necessitates travel in a draw, **valley**, or canyon.

(5) A running fire **should** never be **controlled** from the uphill direction. This entails a high risk to men and equipment. The correct point to begin control is at the tail on the upwind side of the fire line or at the head of the fire when it tops a crest

## CHAPTER 8

## FIRE PREVENTION

**8-1. Introduction**

The purpose of fire prevention is to eliminate fire hazards, or elements which cause fire to occur, or conditions which will contribute to the spread of fire. The firefighter's utmost concern is the prevention of destructive fires. Prevention saves the effort and expense of extinguishing them. It is DA policy that arrangements be made to have firefighters perform fire prevention duties away from the fire station and at the same time be available for fire call.

a. To prevent a situation from being hazardous, one of the three elements of the fire triangle must be removed. Of the three, heat is the undetermined condition, the one which is most generally considered from the standpoint of fire prevention.

b. Effective fire prevention requires the establishment of a well-planned program and the organization, publicity, support, cooperation, inspection, and supervision to implement and maintain it. It also requires the instilling of personal responsibility and interest in individuals so that they will help prevent the loss of property and life by fire due to carelessness. The personal interest and concentrated effort of all concerned, from commanders to supervisors to individuals, is essential if the fire prevention program is to be successful.

**8-2. Cigarettes and Matches**

Smoking is the greatest single cause of fires. The careless discarding of matches, the dropping of hot ashes, and the careless leaving of lit cigarettes are the principal infractions of smokers that cause fires.

a. Smoking does not appear to be a serious cause of fire to most individuals because the great majority have never started a fire by smoking, that they know of. Actually, *anyone* who has carelessly discarded a lighted cigarette may be guilty of having started a fire, even though the cigarette may have been originally dropped upon concrete,

metal, or barren earth. Paper, having a low flash point, is very easy to burn by a lighted cigarette. Thus, emptying of ashtrays into a wastepaper container is foolish even though the cigarette butts apparently are not smoldering.

b. Any type of match may start a fire, but the possibility of its doing so varies greatly according to the type of match. The proper safety match has a head that will not fly off when struck and a stick that is treated to eliminate afterglow. The use of good safety matches should be required, especially in areas near flammable gases, vapors, and materials.

**8-3. Waste**

Waste materials and rubbish are great contributors to the start and spread of fire independent of flammable liquids.

a. Waste materials containing oil have spontaneous ignition characteristics and are very likely to cause fires. A high standard of cleanliness and the complete elimination of loose rubbish from building interiors are unquestionably among the greatest factors in fire prevention. It is the duty not only of fire-inspection personnel but also of all personnel occupying the building to see that poor housekeeping habits are eliminated. When it is impossible or very inconvenient to remove flammable rubbish from the building immediately, such material should be kept in fireproof or fire-resistant containers or inclosures.

b. Clean waste, although not as hazardous as used or reclaimed waste, has occasionally been reported as a source of spontaneous ignition. Consequently all waste, excelsior, straw, sawdust, and burlap should be kept in metal tins with self-closing covers to prevent the admission of oxygen and thus the ignition of the heated combustible substance.

c. Spontaneous ignition occurs under extremely variable conditions. It is difficult to state that a

specific quantity of flammable materials will or will not ignite independent of external heat, since the naked eye cannot see all of the contents of the material ; furthermore, the time factor required for ignition may range from minutes to months.

#### 8-4. Sparks

Live sparks from chimneys and stacks, refuse burners, and other similar sources must be given priority consideration. Spark-arresting screens can be installed over the openings, but their efficiency is limited. A large mesh screen will let many sparks escape. A small mesh screen will soon become carbon congested and impede the passage of smoke. The best procedure is to use medium mesh screens of heat-resisting alloy metal. These screens will require periodic cleaning. Medium mesh will allow only those sparks having a limited "glow life" to escape, retaining those large and more dangerous embers in the stack. During periods of low humidity and high wind velocity, special precautions must be taken depending upon the fire risk in the immediate area.

#### 8-5. Mechanical Devices

Engines of any type, or other machines in which friction is created, are possible sources of fire.

a. A common example of this is a fire caused by overheated bearings. Wherever there are engines, there should be frequent elimination of lint and dust from the immediate surroundings of the moving mechanical device. Also all excessive flammable lubricants should be removed promptly.

b. Grinding wheels and other spark-producing equipment are a frequent cause of fires and should not be permitted in areas which might contain highly flammable gas or vapors. Neither should flammable materials of any type be left in an area where sparks may fall upon them.

c. Blower systems including all duct installations, whether used for ventilation, air conditioning, or dust and vapor elimination, are fire hazards. Most dust, including that of some metals, is an explosion hazard where a spark is possible. These sparks may be struck by fan motors, overheated fan bearings, or the movement of the fan against surrounding metal. Blower fans or their metal housings should consist of nonferrous metal. The ducts must be of metal and free from contact with wood and other flammable material. They must also contain parts which will permit

frequent cleaning and compartment dampers which will isolate the fire to a single section if prevention fails.

#### 8-6. Effect of the Sun

The sun frequently is responsible for fires, though it is usually assisted by some manmade implement.

a. A fire inspector must be especially observant of these implements, because under most conditions they are extremely difficult to detect as fire hazards. For example, forest fires have been known to start from discarded bottles or other fragments of glass left by careless campers. The sun's rays, shining through a piece of glass which may be so ideally curved and placed as to act as a magnifying glass, are concentrated so as to ignite a piece of paper. Similarly, curtains can be ignited by a window pane containing a bubble or some other irregularity. Fire may also occur from such sources as laboratory flasks, fish bowls, water bottles, concave mirrors (which reflect heat), and other common sources. The sun also contributes to spontaneous heating, thus aiding ignition. During warm seasons when buildings are closed for the weekend, sprinkler heads located beneath skylights and in attic spaces may be discharged, often resulting in considerable water damage.

b. The possibility of fire being started by the sun is somewhat remote. However, since numerous conditions may create these so-called freak fires and any one fire may completely destroy a building or many buildings, these possibilities deserve careful consideration.

#### 8-7. Buildings Under Construction

Buildings in their various stages of construction usually have more fire hazards than they do after they are completed.

a. Probably the primary reason for this is the fact that most people cannot visualize a building burning down completely before it is put up completely. Therefore, there is usually no fire-extinguishing equipment immediately available. On an Army base, construction operations are common. The loss of any of these projects by fire, regardless of their stage of completion, may cause severe hardships and serious delays. For this reason, it is recommended that fire extinguishers be made available in proper quantity and be adequately distributed throughout the project. All excess

wood and other combustible materials should be removed promptly. Heaters and heating equipment should be strong and safe. They should be located where they will not ignite other material, and must be constantly attended.

*b.* Combustible materials should not be stored in or near buildings under construction. Gasoline and other volatile liquids should be segregated and stored in standard safety containers, preferably underground if the liquid is kept in any large quantity. Windbreakers and tarpaulins should be properly secured, and their location should be checked for possible fire sources. Welding should be supervised and all adjacent combustible material either removed or adequately protected from the flame and flying embers. Stairways and exits must be clear and properly maintained in order to enable quick evacuation of the structure and for extinguishing the fire in any location.

## 8-8. Heating Systems

Heating systems are a common source of fire during winter seasons in most latitudes. Heating units and their conditions of installation are so variant that it is impossible to deal with each specific hazard in detail here. The best procedure is to inspect each heating system while it is out of operation and also while it is in various phases of operation, and then take the necessary action to eliminate hazards. Any source of heat is a potential fire hazard unless it is so constructed and installed that it will not heat nearby combustible materials to a point where they may ignite. Heating devices, for a proper margin of safety, should be so installed that exposed **woodwork** will not be heated in excess of 160° F. (71° C.). Normally, building codes require that heating units and their conveying ducts be installed a given minimum distance from combustible materials. This condition seems somewhat unimportant if we do **not** take the ventilation and circulation aspects into consideration.

*a. Insulation.* Insulation alone is not a solution to safe heating. Heat from a stove base, for example, has been known to penetrate metal, brick, and asbestos and to char the wood beneath when these materials had no air space below them. Long periods of high temperatures have been known to cause fires under apparently safe conditions. In large rooms, a reasonable clearance between the heating device and the combustible material is the primary requisite. In small rooms the lack of

space may restrict the proper clearance and sometimes even adequate insulation to supply the proper safeguard against the ignition of combustibles. This requires a closer watch on the quantity and consistency of heat and more careful inspections.

*b. Furnaces.* Stationary heating devices are rated in three grades: low, medium and high. Low-grade furnaces develop temperatures up to 600° F. (315° C.). Medium-grade furnaces develop temperatures from 600° F. (315° C.) to 1,500° F. (815° C.). High-grade furnaces create temperatures in excess of 1,500° F. (815° C.) and require 30 feet (9.15 meters) of frontal clearance, 10 feet (3 meters) on the rear and sides, and 15 feet (4.6 meters) of overhead clearance.

*c. Steampipes.* Steampipes of any type may, in the course of time, make charcoal out of wood with which they are in contact. This charcoal is subject to spontaneous ignition because it absorbs great quantities of oxygen from the atmosphere. Steampipes should be wrapped in asbestos or magnesia insulation which has a minimum of 1 inch (2.54 centimeters) of clearance from all woodwork.

*d. Ranges and Ventilating Systems.* Massive ranges and ventilating systems present great hazards in dining halls and other locations where food is prepared for large groups. Hot grease boiling over containers, the residue in the hoods, the area over the range, and the space within the ducts leading away from the hoods are the chief sources of fire danger. Ducts should be made of not less than No. 18 U.S. gage steel, **tightly** riveted at the joints, so that if the grease residue ignites and burns there will be a minimum of damage to the building itself. Access ports should be provided in exhaust ducts to enable periodic cleaning.

*e. Stoves.* Coal and wood stoves should be mounted on a fire-resistant floor and should follow the clearance and ventilating requirements of a low-grade furnace. The stovepipes must be properly installed and must not pass through **confined** spaces in which an ignition temperature could build up. Stovepipes should be properly supported, kept in good repair, and cleaned regularly.

## 8-9. Electricity

**Electricity**, if improperly used, may easily become a major fire hazard and a serious source of danger to personnel.

a. When the simple and proper rules of installation and use are followed, electricity is a superior source of power, illumination, and heat. It may become a fire hazard by overheating, arcing or sparking. *Overheating* is a condition where an overload of electrical current is passed through a wire and the internal heat created by the overload burns through to ignite the insulation covering the wire. This insulation then ignites adjacent combustibles. When an electric motor is overworked or defective, it overheats, and fire results. A single electrical outlet or wire used as a power supply for too many electrical implements will cause *overheating*. *Arcing* is a sustained luminous glow which is formed under certain conditions when a break is made in an electric circuit. An arc light and the breaker points in an automotive distributor system are examples of arcing. *Sparking* is an electrical condition in which light is created, accompanied by a sudden disruptive discharge, between two conductors separated by air or some similar medium. The action of spark plugs in an internal combustion engine is an example of sparking.

b. To minimize these hazards from electrical sources, the equipment and installation should be standardized and properly maintained. It is the job of fire-inspection personnel to see that these hazards are completely eliminated. Being certain that no fires will start from an electrical source today gives no assurance of fire safety next week. Inspectors unable to visit each building daily must help educate the occupants on what constitutes a fire hazard.

c. Electrical installations are made in accordance with national electrical codes, state laws, and municipal ordinances. If these provisions are followed, fire hazards are decreased but certainly not eliminated. Deterioration by use, abuse, and age often requires the replacement of electrical wires and their associated implements. Frequently, crude installations and use of electrical fixtures make for flagrant violations of fire safety rules.

d. Electrical circuits carry currents of varied intensity. When current is suddenly cut off, whether by accident—such as by a loosened contact at a terminal—or by intention, an arc is produced. The magnitude of this arc depends upon the current and amount of voltage involved. At all times the temperature of this arc is very high, and it can ignite combustible materials. In addition, the metal of the conductor usually fuses. This hot, flying metal, along with the **flying**

sparks, **amy** also ignite combustibles and frequently causes ignition of the wire insulation.

e. 'The electric wire, or conductor, as it is technically termed, is normally a negligible consideration from the standpoint of 'overheating tendencies. However, there is a possibility of overloading, for each conductor is rated with a certain maximum capacity. Fire hazards occur in two ways when this capacity limitation is exceeded: through the deterioration of the insulation (which exposes the wire) and through the creation of excessive heat.

#### 8-10. Fuses and Other Safety Devices

Many devices have been designed to give **overcurrent** protection. These devices open the circuit and cut off the current when the electrical flow reaches a given maximum.

a. The most common of these devices is the *fuse*, which contains a strip of metal that overheats and melts when the current exceeds the fuse capacity, thus breaking the circuit. Fuses consist normally of two common types, the plug type and the cartridge type.

b. Another protection against overcurrent is provided by the circuit breaker. This device automatically cuts off the flow of electricity when the **current** becomes excessive.

c. All overcurrent protective devices must be so designed as to confine the arc harmlessly within themselves when they go into operation. Clean contacts at the fuse terminals or boxes are important because dirt can cause overheating and the blowing of fuses.

d. The hazards most likely to be found in **overcurrent** protective devices are as follows :

(1) Plug fuses which have blown out and have had pennies inserted behind them or wires inserted between the broken contacts.

(2) Fuses of a capacity higher than desirable, or circuit breakers with too high a setting.

(3) Fuses or circuit breakers in poor mechanical condition.

(4) Unconfined fuses in an area containing combustible material.

(5) Fuse cabinets with open or missing doors.

(6) Corroded fuses, inclosures, or circuit breakers.

(7) Refillable fuses containing additional metal strips.

(8) **Cartridge fuses** which have been blown and replaced with nails, wires, or other metal.

(9) **Circuit** breakers made useless by the tying or blocking of the tripping element.

### 8-11. Wiring and Switches

There are several recognized methods of installing electrical wiring. Only rigid conduits should be used where gasoline vapors may be **present**. No conductor should be installed, even temporarily, that does not conform to all safety requirements.

a. The hazards most frequently found in electrical wiring are as follows:

(1) Overloaded conductors.

(2) Corrosion of the conductor coverings.

(3) Corrosion and loosening of supports.

(4) **Covers** of outlet boxes or junction boxes removed.

(5) Wiring installed for temporary use.

(6) joints not properly put together.

(7) Flexible conductors hung over nails or other makeshift contrivances which may cause wear and create arcing or sparking.

b. In electrical switches the chief hazard is caused by arcing when the switch is operated. Switches should contain an inclosure that will confine any arc that might occur. The most prominent **hazards** in switches are corrosion, faulty mechanical condition resulting from use or abuse, overheating due to poor contact or an overload of current, inclosures absent or ineffective, and contacts burned or pitted where the circuit is opened or closed.

### 8-12. lamps

The principal types of electric lamps are vapor, incandescent, and arc.

a. In locations where flammable gases, vapors, or dust are present, the improperly equipped lamp becomes an explosion and **fire** hazard. Mercury arc lamps are a spark hazard **if** not confined. The **gas-filled** lamps now in common use generate enough heat to ignite combustibles in contact with, or close to, the globe. Neon **lamps** require a high-voltage supply and offer a hazard from the arcing which this high voltage may create. Portable lamps are frequently used in damp or wet locations. This practice presents both a fire hazard and a personal safety hazard.

b. The hazards most common in portable lamps

are fragile sockets, the use of defective or unapproved cord, the use of frail lamp guards or the absence of any guard, and the failure to provide a disconnection release in the event of strain on the cord. Lamp sockets are not great fire hazards if an approved type of socket containing the correct load limit is used and if the component socket parts are properly assembled.

c. There are many lamps in use that are of substandard construction. When making a fire safety inspection, inspect these lamps carefully. A substandard lamp is a definite fire **hazard**.

### 8-13. Flexible Cords

Flexible cords should be used only when absolutely necessary, for their use constitutes a distinct fire hazard unless careful attention is given to their treatment and condition. Flexible, portable cords are subject to much **abuse**. They contain a conductor of fine strands of wire with an insulating covering of small dimensions, which frequently consists of combustible materials. Instances have occurred where metal-wheeled vehicles have passed over portable, flexible cords and caused critical losses by creating an arc in the presence of gasoline vapors. A cord should be lifted over any heavy moving object instead of the object passing over the cord. The better portable cords are covered with a heavy rubber outer jacket. Constant observation and maintenance of these cords is a paramount safety precaution. Complete replacement of a cord is necessary when appreciable wear becomes evident.

### 8-14. Motors and Generators

Electric motors and generators present a definite fire hazard, since they can produce arcs or sparks and frequently overheat and burn out because of overload.

a. The motor frame should **be** suitably inclosed. Combustible material should be kept away from the vicinity of motors and generators to prevent hazardous conditions resulting from arcing and sparking. **Overcurrent** protection will safeguard against overloading.

b. The **following** are the common precautions required in the use of electric motors to safeguard against fires. They must be kept away from combustible material and out of damp places which subject the motor to corrosive vapors. The **overcurrent** must not exceed **125** percent of its rated capacity. Lint and dust must be kept off the top of

the motor. Special precautions must be taken when starting an electric motor near combustible material because of the arcs and heat produced by the motor. Low voltage at the terminal must be corrected because it will cause the motor to burn out and start a fire. Overloading also produces heat and becomes a **fire** hazard.

### 8-15. Static **Electricity**

Static electricity is generated to an appreciable extent in many industrial and **manufacturing** operations. It is a factor which requires major consideration where aircraft are used.

a. Previously it was believed that static electricity was generated only by friction between two unlike substances. It is now known that static electricity is created by contact between two unlike substances even though no friction is present. Static electricity is known to be a serious fire and explosion hazard in the presence of volatile flammable liquid, flammable gases, highly ignitable fibers, and combustible dusts.

b. In areas where the hazard is great, it is advisable to replace belts with chains and gear drives to eliminate the generation of static electricity. When the construction features cannot be changed to prevent the generation of static electricity, it is also advisable to ground all metal parts which may accumulate an electrical charge. The atmosphere normally is a nonconductor of electricity, but ionized air will normally draw static electricity from charged metal implements. Static neutralizers may be installed to do this.

c. Humidity is an important factor in the ability of static electricity to drain from highly charged metal objects. Where high humidity is present, surface resistance is reduced, and electrical charges are drained off almost as they form. A humidity of 40 to 50 percent generally prevents any quantitative buildup of static electricity.

d. Static electricity is created when gasoline or similar flammable liquids are passed through a hose, poured from one container to another, filtered, or subjected to velocity in almost any manner. These dangerous static charges **frequently** cause serious fires and explosions unless preventive measures are taken.

e. When gasoline is **discharged** through a hose, a copper wire should be installed from the pump through the hose to the nozzle, and the nozzle should be kept in contact with the metal receptacle at all times. In many cases, such as in aircraft

tanks, a separate wire with a male connection is plugged into a static electricity drain installed near the tank opening. This device should be plugged in before the gasoline is allowed to flow through the hose.

### 8-16. General Storage Precautions

In theaters of operations, where materials are stored outside or where they are protected in warehouses, large quantities should be divided and dispersed to discourage fire propagation. At the same time, ample space should be allowed for extinguishment activity and the firefighting equipment. Fire losses are greatly **decreased** if the **various** classes of supplies are stored systematically.

a. **Fire Extinguishers.** Fire extinguishers should be strategically placed in storerooms and other locations where flammables are present for controlling fire at its outbreak. **Instructions** should be provided which inform the occupants of the buildings to call the fire department immediately if fire occurs, then attempt to put out the blaze with first-aid extinguishers. If more than one person is present, one should turn in the alarm while the rest fight the **fire**.

b. **Sign.** Signs should be conspicuously placed where special precautions are necessary which order "no smoking" and other essential precautions. A recommended procedure in the event of fire should also be given. Metal containers, plainly marked for the intended contents, should be placed where needed and a safe **distance** from structures and flammables. Both civilian and military personnel should report any violations of fire regulations without delay to the responsible person in charge.

c. **Fuels.** Engine fuels, lubricants, gasoline, and coal should be stored separately on bases that are without previously installed permanent facilities. Gasoline and oil drums should be **stacked horizontally** in double rows, butt to butt. Flammable liquids should be placed on a slope away **from** danger so that the free liquid will drain off in a safe direction. When storage involves **great** quantities of liquid fuel, it should be segregated into group volumes as small as practicable, with earthen dikes erected around each group to confine the burning limits to single areas or groups.

d. **Ammunition.** All types of ammunition should be stored in isolated areas, in individual piles, separated by enough space to allow passage of **vehicles** for fire extinguishment and for removal of



exposed ammunition to a safe area during the course of a fire. If possible, ammunition piles should be segregated to prevent an individual pile from exploding another or a series of others, causing the complete loss of materials in the area. The distance between piles can be determined by the type of ammunition and its characteristic reaction upon detonation.

#### 8-17. lightning

Lightning is a frequent **cause** of fires. At certain periods in past years it has led the field from the standpoint of monetary losses. 'On bases where there are wooden structures, flammable **liquids**, and ammunition powder, precautions against lightning must be taken. This is especially true in some sections of the United States where the lightning hazard is present for almost 100 days out of every year.

a. Lightning rods prevent damage from lightning if they are properly installed. The rods must extend from 24 inches (0.6 meter) to 60 inches (1.5 meters) above the highest projection of a structure with grounding connections distributed symmetrically around the base of **the** structure. At least two down conductors and ground connections should be made at the opposite horizontal ends of the structure, The lightning rods, conductors, and grounding connections should be made of copper. Where several lightning rods are installed on a structure, they should be bonded together by horizontal conductors following the **roof** edges, roof ridges, and parapets of the structure. Likewise, all down or vertical conductors should be connected to bonded grounding connections. All conductor cables should be not less than 1'7 American wire gage (AWG).

b. All oil tanks, whether of steel or some other material, should be grounded. Direct lightning strikes on the tank may be averted by a network of wires, properly grounded, at least 6 feet (1.8 meters) above the tank. A series of steel masts may be erected around the entire tank farm at such a height that they will not impede ground activity. The masts are then joined with a series of wires which form a horizontal pattern.

c. Structures containing stored explosives need protection not only against direct lightning hits but also against induced sparks caused by a lightning strike in the immediate area. The best location for powder storage is underground or in small **individually** segregated rooms. These rooms

should be covered with earth and equipped with copper cables running across the roof and grounded on each side.

#### 8-18. Painting and Spraying

**In** any location where paint and lacquer spraying is performed, whether it involves vehicles, aircraft, or simply structural interior decorating, it is always fairly certain that flammable solvents, ignitable at low temperatures, are present in the atmosphere. Ventilation is the best insurance against vapor ignition. Each compartment or spray booth should be equipped with an individual **exhaust** duct, including a sparkproof fan. The use of heat for drying purposes increases the **fire** hazard in paint spray areas and increases the necessity for caution. Electrical **hazards** are the greatest source of fire danger in a paint spray area. Spontaneous ignition and careless operation and maintenance habits are also high on the list of fire hazards.

#### 8-19. Miscellaneous

Common deficiencies and conditions, not otherwise covered in this chapter, which require attention during inspections are as follows:

a. *Sprinklered Buildings.* Arrangements should be made to keep at least 18 inches (45.72 centimeters) clearance below sprinkler deflectors to reduce possible obstruction to distribution of water. 'For high-piled combustible stock, increased clearance of 36 inches (91.44 centimeters) or more should be provided. Sprinkler heads **should** not be painted, and painted **heads** must be replaced. Alterations, extensions, additions, or other **modifications** to existing **buildings** should not be made without providing for necessary alteration of the sprinkler system. When new suspended ceilings and similar additions to the building are made, the necessary extension of the sprinkler system may tend to be overlooked. New partitions, unless positioned midway between sprinkler heads or lines, require additional sprinkler heads. A change of occupancy may also **create** conditions that require sprinklers.

b. *Automatic Fire Alarm Systems.* The same conditions as described in **a** above may occur in buildings in which automatic fire alarm systems are installed. All combustible dormitory type buildings with individual sleeping rooms should have automatic fire alarm systems. This is particularly true of former open bay barracks of **com-**

bustible construction which have been modified for individual or two- to four-man sleeping rooms.

c. **Interior Finish and Insulation.** Interior finish and insulation in Army buildings is required to be noncombustible (flame spread rating of not higher than 25 as tested in accordance with ASTM E 84). Combustible material such as plywood, low density fiberboard, or similar material, often installed by troop labor or self-help, should be removed.

d. **Exit Facilities.** Inspection should determine the condition of panic hardware, exit lights, and door swing of exit doors. Exit doors should not have blocks or locks or chains installed unless they are unlocked or removed when the building is occupied. Structures must have two exits; excessive dead-end corridors may require additional exits or outside stairs.

e. **Fire Door.** Fire door closing devices should

be in good operating condition. The doors should not be blocked. Doors such as stairway enclosure doors should be kept closed.

f. **Cleaning with Gasoline.** Cleaning with gasoline or similar flammable liquids is prohibited.

g. **Close-of-Business Inspections.** This inspection, conducted by the building fire marshal, is an important fire prevention practice, particularly in clubs, theaters, and other places of assembly. Trash and smoking material should be removed from the building and upholstered cushions on furniture turned up. Early morning inspections by the fire department are recommended to determine if this has been done.

h. **Hoods.** Hoods over kitchen equipment should be equipped with a washable type filter. This filter should be cleaned weekly, usually in the dishwashing machine. The hood and connecting ducts should also be cleaned regularly.

## APPENDIX A

## REFERENCES

## 1. Army Regulations

AR 50-2	Nuclear Weapons Accident and Incident Control (NAIC)
AR 95-1	Army Aviation-General Provisions
AR 95-26	Aircraft Firefighting and Rescue
AR 310-1	General Policies
AR 320-50	Authorized Abbreviations and Brevity Codes
AR 385-12	Fire Report (Reports Control Symbol ENG-7 (R3))
AR <del>385-17</del>	Fire Extinguishers For Rail, Marine, Amphibious, and Off-the-Road Equipment
AR 385-30	Safety Color Code Markings and Signs
AR 405-45	Inventory of Military Real Property
AR <del>420-70</del>	Buildings and Structures
AR 420-90	Fire Prevention and Protection
AR 500-60	Disaster Relief
AR 611-201	Enlisted Military Occupational Specialists
AR <del>700-68</del>	Safe Handling, Storing, Shipping, Use, and Disposal of Compressed Gas Cylinders

## 2. Field Manuals

FM 5-1	Engineer Troop Organizations and Operations
FM 21-11	First Aid For Soldiers
FM 21-26	Map Reading

## 3. Technical Manuals

TM 5-225	Radiological and Disaster Recovery at Fixed Military Installations
TM 5-687	Repairs and Utilities ; Fire Protection Equipment and Appliances ; Inspections, Operations, and Preventive Maintenance
TM 5-725	Rigging
TM 8-230	Medical Corpsman and Medical Specialist
TM 9-1300-206	Care, Handling, Preservation and Destruction of Ammunition
TM 38-750	Army Equipment Record Procedures

## 4. DA Pamphlets

DA Pam 310-2	Index of Blank Forms
DA Pam 310-4	Index of Technical Manuals, Technical Bulletins, Supply Manuals (Types <b>7, 8, and 9</b> ), Supply Bulletins, and Lubrication Orders
DA Pam 310-6	Index of Supply Catalogs and Supply Manuals
DA Pam 420-2	Management of Fire Prevention and Protection Program

## 5. Other References

SB 700-20	American Society For Testing and Material Designation E 84
TB 5-4200-200-10	Army Adopted Items of Materiel and List of Reportable Items
TB 385-2	Hand Portable Fire Extinguishers Approved For Army Users
	Nuclear Weapons Fire-Fighting Procedures

APPENDIX B

ARMY AIRCRAFT DESIGNATIONS AND FUELS

Helicopter Series			Observation Series		
Former designation	current designation	Fuel	Former designation	Current designation	Fuel
HU-1	UH-1	JP-4	L-19A	O-1A	115/145
HU-1A	UH-1A	JP-4		O-1D	115/145
HU-1B	UH-1B	JP 4		TO-1A	115/145
	UH-1C	JP 4	TL-19D	TO-1D	115/145
HU-1D	UH-1D	JP-4		TO-1E	115/145
	UH-1H	JP 4	L-19E	O-1E	115/145
HO-6	OH-6A	JP 4		O-1F	115/145
	OH-13C	115/145		O-1G	115/145
H-13E	OH-13E	115/145	Utility Series		
H-13G	OH-13G	115/145	Former designation	Current designation	Fuel
H-13H	OH-13H	115/145	U-1A	Same	115/145
H-13K	OH-13K	115/145	L-20A	u-6A	115/145
	OH-13S	115/145	L-23D	U-8D	115/145
H-19C	UH-19C	115/145	RL-23D	RU-8D	115/145
H-19D	UH-19D	115/145	L-23E	U-8E	115/145
H-21B	CH-21B	115/145	L-23F	u-8F	115/145
H-21C	CH-21C	115/145		u-8G	115/145
H-23B	OH-23B	115/145	L-26B	U-9B	115/145
H-23C	OH-23C	115/145	L-26C	U-9C	115/145
H-23D	OH-23D	115/145	RK-26D	RU-9D	115/145
H-23F	OH-23F	115/145		U-10A	115/145
	OH-23G	115/145		U-10D	115/145
H-34A	CH-34A	115/145		u-21	JP 4
H-34C	CH-34C	115/145		C-45 (AF)	91/96 or 115/145
H-37B	CH-37B	115/145		C-47 (AF)	115/145
HC-1B	CH-47A	JP 4	VTOL & STOL Series		
	CH-47B	JP-4	Former designation	Current designation	Fuel
	CH-47C	JP 4	AO-1	OV-1	JP 4
	CH-54A	JP4- or JP-5	AO-1A	OV-1A	JP 4
	AH-1G	JP 4	AO-1B	OV-1B	JP 4
	AH-56A	JP 4	AO-1C	OV-1C	JP 4
	TH-55A	JP 4	CV-2A	C-?A (AF)	115/145
	TH-13T	115/145		C-130 (AF)	JP 4
			AC-1A	CV-2B (AF)	115/145
				C-123 (AF)	115/145
				C-131 (AF)	115/145
			Training Series		
				T-42A	115/145
				T-41B	115/145
				T-41B	115/145
				T-41D	115/145

## INDEX

	Paragraph	Page
<b>Accidents</b> -----	<b>6-1</b>	<b>6-1</b>
<b>Accordion load</b> -----	<b>4-23a</b>	<b>4-18</b>
<b>Adapter</b> -----	<b>4-12a</b>	4 6
<b>Advancing hose:</b>		
<b>With a handline</b> -----	<b>4-26g</b>	422
Up a <b>ladder</b> -----	<b>4-26e</b>	421
Up a stairway -----	<b>4-26f</b>	421
<b>Advancing the lines</b> -----	<b>4-26d</b>	421
<b>Aid, first. (See First aid.)</b>		
<b>Aircraft:</b>		
<b>Anti-icing</b> -----	<b>5-13</b>	6-13
Auxiliary power plants -----	<b>5-12d</b>	6-13
Components -----	<b>5-7</b>	<b>5-2</b>
<b>Crew entrapment</b> -----	<b>5-15</b>	<b>5-13</b>
Ejection seat -----	<b>5-26b</b>	<b>5-18</b>
Electrical system -----	6-12	<b>5-12</b>
Emergency rescue procedures -----	6-24	<b>5-17</b>
Engines -----	6-7	6-2
<b>Fires</b> -----	<b>6-23</b>	6-8
Firefighting -----	6-1	6-1
Fire extinguishers -----	6-26	<b>5-17</b>
Fire hazards -----	6-6, <b>5-7</b> , 6-23	6-2, 6-8
Flammable materials -----	6-3	6-1
<b>Fuel system</b> -----	6-9	<b>5-10</b>
Heater system -----	6-14	<b>5-13</b>
Ignition -----	<b>5-12c</b>	6-12
Models -----	6-26	<b>5-18</b>
Oil system -----	6-10	6-11
Oxygen system -----	6-11	<b>5-11</b>
Power plants -----	6-7	6-2
<b>Rescue</b> -----	6-1	<b>5-1</b>
Traffic pattern -----	<b>5-18</b>	6-14
Tubing identification -----	6-3	<b>5-10</b>
Airfield emergency -----	6-22	<b>5-15</b>
<b>Alarm systems</b> -----	1-20, 1-24	1-8, 1-12
Alphabet, phonetic -----	1-22-c	<b>1-9</b>
Alpha radiation -----	<b>6-11a</b>	<b>6-3</b>
Aluminized covers -----	<b>2-3a</b>	2-3
<b>Ammunition:</b>		
Deterioration -----	<b>7-2b</b>	7-1
Hazards -----	7-2	7-1
Safety violations -----	<b>7-2c</b>	7-1
Stacking -----	<b>7-3a</b>	7-3
Storage -----	<b>8-16d</b>	<b>8-6</b>
Storage chart -----	<b>7-4a</b>	7-4
Anti-icing system -----	<b>5-13</b>	6-13
<b>Apparatus:</b>		
<b>Breathing</b> -----	2-4	<b>2-3</b>
Appliances -----	2-14	2-21
Application of water -----	4-11	4-4
Arcing -----	<b>3-5b(4)</b>	3-4
Arm-lift resuscitation -----	4-62	4-66
Artificial respiration -----	<b>4-58</b> , <b>4-63</b>	4-62, 4-67
Atmospheric pressure -----	<b>4-10b</b>	4-4
<b>Attacking the fire</b> -----	<b>6-16e</b>	6-4

	Paragraph	Page
Automatic and manual fire alarm system.....	1-17a	1-7
Automatic, manual, and water flow alarm system .....	1-20	1-8
Aviation gasoline .....	5-4	5-1
Ax:		
Cutting .....	4-39a	4-40
Fire .....	4-39c(4), 4-39h	4-41, 4-46
Hitch .....	4-16f	4-6
Backfires .....	7-11i	7-15
Ball valve .....	2-10a	2-19
Batteries .....	5-12b	5-12
Battering ram .....	4-39c	4-41
Becket bend .....	2-16i	2-26
Bleeding:		
External .....	4-56	4-60
Internal .....	4-57	4-62
Booster line .....	4-36a	4-34
Boots .....	2-2d	2-1
Bowline .....	2-16g	2-26
Breathing apparatus .....	2-4	2-3
Breathing apparatus limitations .....	2-4e	2-6
Breathing apparatus for special situations .....	2-4d(4)	2-6
Broken back .....	4-66d	4-69
Broken neck .....	4-66e	4-71
Building under construction .....	8-7	3-2
Bunker coat .....	2-2a	2-1
Bunker trousers .....	2-2b	2-1
Burns .....	4-67	4-73
Butterfly valve .....	2-10c	2-20
Carbon dioxide extinguishers .....	2-19	2-28
Care of hose .....	2-7b, 2-7c	2-11
Carry:		
Fireman's .....	4-49	4-55
Hose .....	4-26	4-17
Ladder .....	4-33	4-27
One-man method .....	4-48a	4-55
Pack-strap .....	4-50	4-66
Rescue .....	4-48	4-55
Shoulder .....	4-30b	4-25
Tools .....	4-39i	4-47
Two-man method .....	4-48b, 4-51	4-55, 4-57
Underarm .....	4-26d	4-21
Causes of fires .....	8-2-8-6	8-1, 8-2
Cease operations signal .....	1-23c	1-12
Ceilings .....	4-39g	4-46
CF3Br .....	4-3	4-1
Characteristics of fire .....	3-1	3-1
Charged line .....	1-23a	1-9
Chemical extinguishment agents .....	3-2	3-1
Chemical heat energy .....	3-5a	3-3
Chemical munitions markers .....	7-5	7-7
Chemistry of fire .....	1-3a, 3-1	1-1, 3-1
Best-pressure resuscitation .....	4-62	4-66
Chief:		
Assistance .....	1-7b	1-3
Crew .....	1-7d	1-4
Fire .....	1-7a	1-3
Station .....	1-7c	1-4
Chimney hitch .....	2-16e	2-25
Clamp, hose .....	2-14d	2-22
Classes of fire .....	3-6	3-4
Classes of fire trucks:		
600 .....	2-5b	2-6
530B .....	2-5c	2-7

	Paragraph	Page
Classes of fire trucks-Continued		
<b>580C</b> -----	2-5 <i>d</i>	2-7
<b>750A</b> -----	2-5 <i>a</i>	2-6
Climbing, ladder -----	4-26	4-33
Closing in on the fire -----	4-71	4-76
Clothing:		
Maintenance -----	2-2 <i>f</i>	2-2
Normal protective -----	2-1, 2-2	2-1
Special protective -----	2-2	2-3
Clove hitch -----	2-16 <i>c</i>	2-24
Coat, bunker -----	2-2 <i>a</i>	2-1
Codes, color -----	6-8	6-10
Coiling a <b>handline</b> -----	2-16 <i>a</i>	2-24
Color codes -----	6-g	6-10
Combustible metal agent -----	2-26	2-38
Combustible vapors -----	3-3 <i>b</i> , 3-3 <i>c</i>	2-2
Combustion -----	3-1, 2-2, 3-4 <i>a</i> 3-5 <i>a</i> (1), 4-41	3-1, 2-2, 3-3, 4-47
Communications -----	1-19-1-24	1-7-1-12
Compressed air, self-contained, demand breathing apparatus -----	2-4 <i>c</i>	2-4
Conduction -----	1-3 <i>d</i>	1-1
Connection:		
Siamese -----	2-11 <i>b</i>	2-21
<b>Wye</b> -----	2-11 <i>a</i>	2-20
Construction -----	1-3 <i>d</i>	1-1
<b>Control, fire</b> -----	4-2, 4-69	4-1, 4-74
<b>Controlling charged line</b> -----	4-29	4-29
<b>Cords, flexible</b> -----	8-13	8-5
Coupling:		
Breaking -----	2-8 <i>h</i>	2-16
Damage -----	2-8 <i>j</i>	2-16
Double -----	2-8 <i>b</i> (1)	2-11
Expansion ring -----	2-8 <i>f</i>	2-13
Female -----	2-8 <i>b</i> (2)	2-12
Gasket -----	2-8 <i>g</i> (2)	2-12
Hose -----	2-8	2-11
Lug -----	2-8 <i>e</i>	2-13
Making up -----	2-8 <i>g</i>	2-14
Male -----	2-8 <i>b</i> (1)	2-11
One-man coupling procedure -----	2-8 <i>g</i> (1)	2-14
<b>Quarter turn</b> -----	2-8 <i>b</i> (3)	2-12
Reducing -----	2-8 <i>b</i> (3)	2-12
Screw type -----	2-8 <i>c</i>	2-12
Sleeves -----	2-8 <i>i</i>	2-16
Snap -----	2-8 <i>b</i> (3)	2-12
Two-man coupling procedure -----	2-8 <i>g</i> (2)	2-16
Use -----	2-8 <i>a</i>	2-11
Couriers -----	6-5	6-1
Covering exposures -----	4-1	4-1
Covers:		
Aluminized -----	2-3 <i>a</i>	2-3
Salvage -----	4-46 <i>b</i>	4-62
Crash:		
Rescue -----	6-24	5-17
Stations -----	1-10	1-6
Crew:		
Chief -----	1-7 <i>d</i> , 4-79	1-4, 4-80
<b>Entrapment</b> -----	6-16	5-13
Cross <b>body</b> hose beds -----	4-21 <i>b</i>	4-12
Cross fold hose finish -----	4-24 <i>b</i>	4-16
Cross ventilation -----	4-44 <i>b</i>	4-61
Crowbar -----	4-39 <i>c</i> (7)	4-41
Crown fires -----	7-10 <i>b</i>	7-13
<b>Cutting</b> with ax -----	4-39 <i>a</i>	440

	Paragraph	Page
DA Forms -----	1-7f, 1-16	1-4, 1-6
Deck pipe -----	2-9f	2-19
Decontamination -----	6-16f	6-5
Decrease pressure signal -----	1-23e	1-12
Deluge set -----	2-9f	2-19
Demand breathing apparatus -----	2-4b	2-4
Department radios -----	1-21	1-8
Design, aircraft -----	6-6	6-2
Determining the cause of fire -----	4-76	4-79
Devices:		
Combine flow -----	2-11	2-20
Control flow -----	2-10	2-19
Divide flow -----	2-11	2-20
Master stream -----	2-9f	2-19
Mechanical -----	8-5	8-2
Protective -----	4-46c	4-53
Safety -----	8-10	8-4
Dining facilities -----	1-12	1-5
Discharge, rate -----	4-9, 4-13a	4-3, 4-6
Disposal teams -----	6-6	6-1
Divided load -----	4-21a	4-11
Donut roll -----	4-19a	4-9
Door opener -----	4-39c	4-41
Doors -----	4-39b, 4-39c	4-41
Double donut roll -----	4-19b	4-9
Drafting sleeve mallet -----	2-14a	2-21
Drafting water -----	4-10	4-4
Drain, water -----	4-46c	4-63
Drills, pumper -----	4-18	4-8
Driver qualification record -----	1-7f	1-4
Dutchman -----	4-23a(2)	4-13
Eductors -----	2-13	2-21
Electrical heat energy -----	3-5b	3-4
Arcing -----	3-5b(4)	3-4
Dielectric -----	3-5b(3)	3-4
Induction -----	3-5b(2)	3-4
Lightning -----	3-5b(6)	3-4
Resistance -----	3-5b(1)	3-4
Static -----	3-5b(5)	3-4
Electricity -----	8-9	8-3
Electric shock -----	4-65	4-67
Electric system -----	5-7a(2), 5-7b(2), 5-12	5-2, 5-8, 5-12
Emergency judgment test -----	1-7f	1-4
Emergency, off the airfield -----	5-23	5-15
Emergency, on the airfield -----	5-22	5-15
Engines:		
Opposed design -----	5-7	6-2
Radial design -----	5-7a(1)	6-2
Reciprocating -----	5-7a	6-2
Turbine -----	5-7b	5-8
Entering -----	4-45	4-51
Entrapment, crew -----	5-15	5-13
Entry, forcible -----	4-39	4-40
Equipment, firefighting units -----	1-6	1-2
Estimate of loss -----	4-77	4-79
Estimating the fire -----	7-11b	7-13
Evaluation of situation -----	4-42, 7-11b	4-48, 7-13
Explosion, nuclear -----	6-8	6-2
Explosive:		
Kinds of fire -----	7-4	7-4
Limits -----	3-3d	3-2
Symbols -----	6-13	6-3



	Paragraph	Page
Exposures, covering -----	4-1	4-1
External bleeding -----	4-56	4-60
Extinguishers:		
Aircraft -----	5-25	5-17
Bromotrifluoromethane (CF <sub>3</sub> Br) -----	2-24	5-17
Carbon dioxide -----	2-19	2-28
Dry chemical -----	2-24	2-31
Dry powder -----	2-25	2-32
Familiarization -----	5-26	2-33
Fire -----	2-17	2-28
Fixed -----	5-25	5-17
Foam -----	2-23	2-31
Inspection -----	2-18	2-28
Portable -----	5-25	5-17
Pressurized water -----	2-21	2-29
Pump type, water -----	2-20	2-29
Soda-acid -----	2-22	2-30
Winterization -----	2-28	2-34
Extinguishment, classes of fire -----	4-3	4-1
Eye splice -----	2-16b	2-24
Facilities for firefighters :		
Crash stations -----	1-10	1-5
Dining -----	1-12	1-5
Heat -----	1-13	1-5
Sanitation -----	1-13	1-5
Sleeping quarters -----	1-11	1-5
Structural stations -----	1-9	1-5
Training -----	1-14	1-5
Factor, time -----	6-16c	6-5
Factors affecting friction loss -----	4-12, 4-14	4-5, 4-6
Female couplings -----	2-8b(2)	2-12
Final action -----	4-78	4-80
Finish:		
Doughnut-roll -----	4-19a	4-9
Hose-load -----	4-20	4-10
Rip-rap load -----	4-24b	4-15
Skid load -----	4-24c	4-15
Fire:		
Army aircraft -----	6-23	6-8
Ax -----	4-39a	4-40
Backfires -----	7-11i	7-15
Breaks -----	7-11h	7-15
Characteristics -----	3-1	3-1
Chemistry -----	1-3a, 3-1	1-1, 3-1
Chief -----	1-7a	1-3
Classes -----	3-6	3-4
Closing in on -----	4-71	4-75
Clothing maintenance -----	2-2f	2-2
Control methods -----	4-2, 4-69	4-1, 4-74
Crown -----	7-10b	7-13
Department radios -----	1-21	1-8
Determining the cause -----	4-76	4-79
Determining the origin -----	4-75	4-77
Estimating -----	7-11b	7-13
Estimating loss -----	4-77	4-79
Extinguishers -----	2-17, 7-3b	2-28, 7-3
Extinguishment -----	4-69, 4-71, 8-16a	4-74, 4-75, 8-6
Extinguishment, classes -----	4-3	4-1
Grass -----	7-10b, 7-11d	7-13, 7-14
Ground -----	7-10b	7-13
Hazards -----	7-2, 8-2-8-19	7-1, 8-1-8-7
Hazard inspection report -----	1-17b	1-7

	Paragraph	Page
Fire-Continued		
<b>Hazards, fire aircraft</b> -----	<b>5-11b</b>	6-12
Investigation -----	4-73, 4-74	4-77
Locating -----	4-70	4-74
<b>Miscellaneous</b> -----	<b>7-1</b>	7-1
Missile -----	6-22	8-7
Motor vehicle -----	<b>7-6</b>	7-7
Natural cover -----	7-8	7-11
Nature -----	3-2	3-1
Nuclear -----	<b>6-12</b>	6-3
Origin -----	4-76	4-77
Overhaul -----	4-72	4-76
Parts of -----	<b>7-10a</b>	7-12
Point -----	<b>3-3f</b>	3-2
Prevention -----	<b>1-5a</b> , 7-3, <b>8-1</b> 1--2, 7-3, 8-1	8-1
Properties -----	<b>3-3</b> , 4-6	3-2, 4-2
Protection -----	<b>1-5</b>	1-2
Protection personnel -----	<b>7-3d</b>	7-4
Protection specialist -----	1-3, <b>7-3d</b>	1-1, 7-4
<b>Rail</b> -----	<b>6-18</b>	<b>6-6</b>
Records -----	<b>4-78</b> , 4-79	4-80
Shortage -----	<b>6-17</b>	<b>6-5</b>
spot -----	<b>7-10b</b>	7-13
<b>Surface</b> -----	<b>7-10b</b>	7-13
Symbols -----	<b>6-13</b>	<b>6-8</b>
Tactical vehicle fires -----	<b>6-20</b>	<b>6-6</b>
<b>Tail</b> -----	<b>7-10a</b>	7-12
Tetrahedron -----	3-2	3-1
Timber -----	<b>7-11d</b>	7-14
Transport vehicle -----	<b>6-19</b>	<b>6-6</b>
Triangle -----	3-2	3-1
Truck operator training -----	<b>1-7f</b>	1-4
Trucks -----	2-6	2-6
Firebreaks -----		
Firefighter <b>facilities</b> -----	<b>1-8—1-14</b>	1-4, 1-6
Firefighter <b>responsibilities</b> -----	1-7	1-3
Firefighters -----	<b>1-7e</b>	1-4
<b>Firefighting:</b>		
Aircraft -----	6-1, <b>5-2</b> , 6-6	6-1, 6-2
Color codes -----	<b>5-8b</b>	6-10
Communications -----	6-20	6-16
Coordination -----	6-19	6-16
Equipment -----	1-6	1-2
Evaluation -----	4-42	4-48
Forcible entry -----	4-39, 4-46	4-40, 4-61
<b>Hydraulics</b> -----	4-4	4-2
Natural cover -----	7-11	7-13
Nuclear weapons -----	<b>6-1—6-23</b>	<b>6-1—6-8</b>
Organization -----	1-6-1-7	1-2, 1-3
Salvage -----	<b>4-40a</b>	4-47
Situation (sizeup) -----	4-38	4-39
Tactics -----	4-1	4-1
Teams -----	1-6	1-2
Techniques -----	4-1	4-1
Tools -----	<b>7-11a</b>	7-13
Units -----	1-6	1-2
Ventilation -----	<b>4-40b</b> , 4-44, 4-48	4-47, <b>4-50</b> , 4-66
Fireman's carry -----	4-49	4-66
First aid:		
Artificial respiration -----	4-68	4-62
Artificial respiration <b>followup</b> -----	4-63	4-67
Broken back -----	<b>4-66d</b>	4-69
Broken neck -----	<b>4-66e</b>	4-71

	Paragraph	Page
<b>First aid-Continued</b>		
Burns -----	4-67	4-73
Chemical burns -----	4-675	4-74
Chest-pressure arm-lift resuscitation -----	4-62	4-66
<b>Digital pressure</b> -----	<b>4-56b</b>	4-60
<b>Direct pressure</b> -----	<b>4-56a</b>	4-60
Electric shock -----	4-65	4-67
External bleeding -----	4-56	<b>4-60</b>
Fracture -----	4-66	4-67
Fractured clavicle -----	<b>4-66g</b>	4-72
Fractured jaw -----	<b>4-66h</b>	4-73
Fractured ribs -----	<b>4-66f</b>	4-71
Heat stroke -----	4-68	4-74
Internal bleeding -----	4-57	4-62
Mouth-to-mouth resuscitation -----	<b>4-59</b> , 4-60	4-63, 4-64
Mouth-to-nose resuscitation -----	4-61	4-64
Requirements -----	4-54	4-60
Shock -----	4-64	4-67
Short distance transfer -----	4-55	4-60
Siivester resuscitation method -----	4-62	4-66
Splinting -----	<b>4-66c</b>	4-68
Sunburn -----	<b>4-67b</b>	4-74
Thermal burns -----	<b>4-67a</b>	4-73
Thumb-jaw-lift resuscitation -----	4-59	4-63
Tourniquet -----	<b>4-56c</b>	4-61
<b>Flammable limits</b> -----	<b>3-3d</b>	3-2
Flammable (explosive) range -----	<b>3-3e</b>	3-2
Flammable material in aircraft -----	5-3	5-1
Flank -----	<b>7-10a(2)</b>	7-12
Flash point -----	<b>3-3f</b>	3-2
Flatioad -----	<b>4-23b</b>	4-13
Flatsinglelength hose fold -----	<b>5-19d</b>	5-15
Flexible cords -----	8-13	8-5
Floors -----	<b>4-39f</b>	4-46
Foam extinguishers -----	2-23	<b>2-31</b>
Fog nozzles -----	<b>2-9a</b>	2-16
Forcible entry -----	4-39	4-40
Forms -----	1-16	1-6
Forward, carrying hose -----	<b>4-26d</b>	4-21
Four-way switch valve -----	<b>2-11d</b>	2-21
Fractured clavicle -----	<b>4-66g</b>	4-72
Fractured jaw -----	<b>4-66h</b>	4-73
Fractured ribs -----	<b>4-66f</b>	4-71
Fractures -----	4-66	4-67
Friction heat -----	<b>3-5c(1)</b>	3-4
Friction loss -----	4-12, 4-14	4-5, 4-6
Fuel, jet (app II) -----	5-45	5-2
Fuel leg -----	3-2	3-1
Fuel storage -----	<b>8-16c</b>	8-6
Fuel system -----	5-9	<b>5-10</b>
Furnaces -----	<b>8-8b</b>	8-3
Fuses -----	8-10	8-4
G-I powder -----	<b>2-25a</b>	2-32
Gasoline, aviation -----	5-4	<b>5-1</b>
Gas turbine -----	<b>5-7b</b>	5-8
Gated wye -----	<b>2-11a</b>	2-20
Gate valve -----	<b>2-10b</b>	2-20
Generators -----	<b>8-14</b>	8-5
Glass, skyiight -----	<b>4-39h</b>	4-46
Gloves -----	<b>2-2e</b>	2-1
Goggles -----	<b>2-3c</b>	<b>2-3</b>
Grass fires -----	<b>7-11e</b>	7-14
Ground fires -----	<b>7-10b(1)</b>	7-13
Guide plate, pump operator's -----	4-17	4-8

	Paragraph	Page
<b>Handline:</b>		
Advancing hose -----	426g	4-22
Coiling -----	2-16a	2-24
Use -----	2-16	2-24
Hand signals -----	1-23	1-9
Harness, parachute -----	5-24b (3)	5-17
<b>Hazards</b>		
Aircraft fire -----	5-5, 6-23	6-2, 6-8
Ammunition -----	8-16d	8-6
Fire -----	7-2, 8-2, 8-19	7-1, 8-1, 8-7
Nuclear -----	8-9	6-2
Head, natural cover fire -----	7-10a	7-12
<b>Heat:</b>		
Compression -----	3-5c(2)	3-4
Energy sources -----	3-5	3-3
Facilities -----	1-13	1-6
Log -----	3-2	3-1
Nuclear -----	3-5d	3-6
Spontaneous -----	3-5a(2)	3-3
Stroke -----	4-68	4-74
Systems -----	8-8, 6-14	8-3, 6-13
Helicopter -----	5-6b, 6-26	6-2, 6-18
Helmet, plastic -----	2-2c	2-1
Highbee cut -----	2-8c	2-12
Highbee thread indicator -----	2-8c	2-12
High explosives -----	6-9b, 5-9c	6-2, 6-10
<b>Hitch:</b>		
Chimney -----	2-16e	2-26
Clove -----	2-16c	2-24
Half -----	2-16d	2-26
Tool -----	2-16f	2-26
Hood -----	2-3b	2-3
Horseshoe load -----	4-23c	4-14
<b>Hose:</b>		
Accordion load -----	4-23a	4-13
Advancing by hand -----	4-26d	4-21
Beds -----	4-21	4-11
Care -----	2-7b	2-11
Carries -----	4-26	4-17
Clamp -----	2-14d	2-22
Couplings -----	2-8	2-11
Drills -----	4-18	4-8
Drying -----	2-7e	2-11
Folds -----	4-19	4-9
Functions -----	4-22	4-12
Hoist -----	2-14b	2-22
Holder -----	2-14b	2-22
Inspection -----	2-7d, 4-26	2-11, 4-16
Jacket -----	2-14c	2-22
Layouts -----	4-26, 4-26c	4-17, 4-20
Lengthening -----	4-28	4-22
Lines -----	4-26d	4-21
Load finish -----	4-24	4-16
Loads -----	4-20	4-10
Maintenance -----	2-7c, 4-26	2-11, 4-16
Moving -----	4-30	4-26
Record -----	2-7h	2-11
Replacing damaged couplings -----	2-7g	2-11
Replacing section -----	4-27	4-22
Reverse lay -----	4-26b	4-20
Rolls -----	6-19	6-16
Rope -----	2-6b, 2-14b, 4-26e, 426g	2-9, 2-22, 2-33, 4-22
Salvaging -----	2-7g	2-11

	Paragraph	Page
<b>Hose-Continued</b>		
Securing -----	2-14b	2-22
Standard loads -----	4-23	4-12
Storage -----	2-7f	2-9
Straight lay -----	4-26a	4-17
Strap -----	4-26e (2)	4-21
Tests -----	2-7d	2-11
Types -----	2-7a	2-11
Hydrant -----	4-36b	4-36
Hydrant wrench -----	2-14a	2-21
Hydraulics -----	4-4-4-17	4-2-4-8
Ideal stream -----	4-13	4-6
Ignition -----	3-4a, 5-12c	3-2, 5-12
Ignition temperature -----	3-3a	3-1
Increase pressure signal -----	1-23d	1-12
Inspection, hose -----	2-7d	2-11
Insulation -----	8-8a	8-3
Internal bleeding -----	4-57	4762
Investigation, fire -----	4-73, 4-74	4-77
Jacket, hose -----	2-14c	2-22
Jet fuel -----	5-4b	6-2
<b>Knot:</b>		
Becketbend -----	2-16h	2-26
Bowline -----	2-16g	2-26
Bowline on a bight -----	2-16g	2-26
Square -----	2-16f	2-26
<b>Ladder:</b>		
Advancing hose -----	4-26e	4-21
Baby extension -----	4-32b	4-26
Bangor -----	4-32d, 4-34c	4-27, 4-31
Bed -----	2-15a	2-23
Carrying -----	4-33	4-27
Climbing -----	4-36	4-33
Drills -----	4-18	4-8
Fly -----	2-15a, 4-32	2-23, 4-26
Kinds -----	2-16, 4-32	2-23, 4-26
Lowering victim -----	4-63	4-68
Parts of -----	2-15a, 4-31	2-23
Pipe -----	2-9f	2-19
Raising -----	4-34	4-28
Standard -----	2-15a	2-23
Straight -----	2-15c, 4-32a	2-23, 4-26
Trussed -----	4-31c	4-25
Lamps -----	8-12	8-5
<b>Lay:</b>		
Reverse -----	4-26b	4-20
Straight -----	4-26a	4-17
<b>Layout:</b>		
Hose -----	4-26, 4-26c	4-17, 4-20
Principles -----	4-26c	4-20
Lengthening a hose -----	4-28	4-22
Lightning -----	8-17	8-7
Lights -----	2-6a	2-9
Light water -----	4-3	4-1
Limits, explosive -----	6-16a, 6-16b	6-4
<b>Line:</b>		
Advancing -----	4-26d	4-21
Booster -----	4-36a	4-34
Charged -----	1-23a	1-9
<b>Load:</b>		
Accordion -----	4-23a	4-13
Divided -----	4-21a	4-11

	<b>Paragraph</b>	<b>Page</b>
Load-Continued		
Finish .....	4-24	<b>4-15</b>
Horseshoe .....	<b>4-23c</b>	4-14
Hose .....	4-20	4-10
Shoulder .....	<b>4-30b</b>	<b>4-25</b>
Skid .....	<b>4-24c</b>	<b>4-15</b>
Locating the fire .....	<b>4-70</b>	4-74
Log .....	<b>1-17d</b>	1-7
Loss:		
Estimate .....	<b>4-77</b>	4-79
Friction .....	4-12, 4-14	4-6, 4-6
Lowering and raising a victim .....	4-53	4-38
Lowering victim on ladder .....	<b>4-53</b>	<b>4-58</b>
Lubricating oil .....	<b>5-4a</b>	<b>5-1</b>
Lugs .....	<b>2-8c</b> , 2-86	2-12, 2-13
Maintenance :		
Clothing .....	<b>2-2f</b>	2-2
Hose .....	<b>2-7c</b> , 4-26	2-11, <b>4-15</b>
Male coupling .....	<b>2-8b (1)</b>	2-12
Mallet .....	<b>2-14a</b>	2-21
Mathematics .....	<b>1-3c</b>	1-1
Measures, safety .....	4-43	<b>4-50</b>
<b>Mechanical devices</b> .....	8-6	a 2
Mechanical heat energy .....	<b>3-5c</b>	3-4
<b>Miscellaneous fires</b> .....	7-1	7-1
Missile fires .....	6-22	6-7
Met-L-X .....	<b>2-26b</b>	2-33
Motors and generators .....	<b>8-14</b>	<b>8-5</b>
Motor vehicle fires .....	7-6	7-7
Mouth-to-mouth resuscitation .....	<b>4-59</b> , 4-60	4-63, 4-64
Mouth-to-nose resuscitation .....	4-61	4-64
National standard fire hose thread (NST) .....	<b>2-8b</b>	2-11
NST .....	<b>2-8b</b> , <b>2-8c</b>	2-11, 2-12
Natural-cover fires :		
Attacking methods .....	<b>7-11c</b> , <b>7-11f</b>	<b>7-13</b> , 7-14
Burning rate .....	<b>7-10d (3)</b>	7-13
Control .....	<b>7-11i</b>	<b>7-15</b>
Fire .....	7-10	7-12
Fire flank .....	<b>7-10a (2)</b>	7-12
Fire head .....	<b>7-10a (1)</b> , <b>7-10a (4)</b>	7-12
Fire tail .....	<b>7-10a (1)</b>	7-12
Kinds .....	<b>7-10b</b>	7-13
Movement .....	<b>7-10a (4)</b>	7-12
Self protection .....	<b>7-11k</b>	7-16
Nature of fire .....	3-2	3-1
Navy lug .....	<b>1-8e</b>	1-4
Normal protective clothing .....	2-2	2-1
Nozzle :		
Applicator .....	<b>2-9d</b>	<b>2-17</b>
Cellar pipe .....	<b>2-9e (2)</b>	2-18
Combination .....	<b>2-9c</b>	2-17
Distributor .....	<b>2-9e (1)</b>	2-18
Fog .....	<b>2-9a</b>	2-16
Fog tip .....	<b>2-9a</b> , <b>2-9c</b> , <b>2-9d</b>	2-16, 2-17
Friction .....	<b>4-16e</b>	4-6
High velocity .....	<b>2-9a</b>	2-16
Low velocity .....	<b>2-9d (1)</b>	2-17
Master stream devices .....	<b>2-9f</b>	2-19
Monitor .....	<b>2-9f</b>	2-19
Partition .....	<b>2-9d (3)</b>	2-18
Pressure .....	4-16	4-6
Puncture .....	<b>2-9d (2)</b>	2-17

	Paragraph	Page
<b>Nozzle—Continued</b>		
<b>Size</b> .....	4-16, 7-9a	4-6, 7-12
Solid stream .....	2-9b	2-17
Special .....	7-7	7-10
Types .....	2-9	2-16
<b>Nuclear:</b>		
Body effects .....	6-11b	6-3
Decontamination .....	6-6	6-1
Disposal teams .....	6-6	6-1
Emergency firefighting procedures .....	6-15	6-4
Explosion .....	6-3, 6-13	6-2, 6-3
General firefighting procedures .....	6-16	6-4
Grouping of explosives .....	6-13a	6-3
Fire .....	6-13b	6-3
Firefighting plans .....	6-14	6-4
Fire symbols .....	6-13b	6-3
Hazards .....	6-9	6-2
Material intake .....	6-11c	6-3
Missile fires .....	6-22	6-7
Rail fires .....	6-18	6-6
Responsibility .....	6-3, 6-4	6-1
Safety design .....	6-7	6-2
Storage fires .....	6-17	6-6
Tactical vehicle fires .....	6-20	6-6
Time factor .....	6-16c	6-4
Transport vehicle fires .....	6-19	6-6
Weapon firefighting .....	6-1	6-1
Weapon operation fires .....	6-21	6-7
Weapons couriers .....	6-5	6-1
Weapons decontamination and disposal teams .....	6-6	6-1
Yield .....	6-10	6-3
Office buildings .....	8-19	8-8
Off-the-airfield emergency .....	5-23	6-16
Oil, lubricating .....	5-4a	6-1
Oil pump .....	5-10d	6-11
Oil system .....	6-10	6-11
Oil tank .....	5-10b	6-11
On-the-airfield emergency .....	6-22	6-16
Opener, door .....	4-39c	4-41
Operations, pumping .....	4-36	4-34
Organization, firefighting .....	1-6-1-7	1-2, 1-3
Origin of fire .....	4-75	4-77
Overall view of fire protection .....	1-6	1-2
Overhaul operation .....	1-5b, 4-72	1-2, 4-76
Overheating .....	8-8, 8-9	8-3
Oxidation .....	3-4a, 3-4c, 3-5a	3-2, 3-3
Oxygen leg .....	3-2	3-1
Oxygen system .....	6-11	6-11
Pack-strap carry .....	4-60	4-66
Paint .....	8-18	8-7
Parachute harness .....	5-24b (3)	6-17
Pattern, traffic .....	6-18	6-14
Phonetic alphabet .....	1-22c	1-9
Physics .....	1-3b, 3-1	1-1, 3-1
Pike pole .....	4-39d (6)	4-44
Pin lug .....	1-8e	1-4
Plaster, removing .....	4-39g	4-46
Plastic helmet .....	2-2c	2-1
Plate, guide .....	4-17	4-8
<b>Point:</b>		
Fire .....	3-3f	3-2
Flash .....	3-3f	3-2
Policies of fire protection .....	1-4	1-2

	Paragraph	Page
Portable fire extinguishers -----	5-25, 7-3b	5-17, 7-3
Precautions, storage -----	8-16	8-6
Pressure, nozzle -----	4-16	4-6
Pressure of water -----	4-8	4-3
Pressurized water extinguishers -----	2-20	2-29
Prevention of fire -----	3-4, 7-3, 8-1	3-2, '7-3, 8-1
Principles of hose layout -----	4-26c	4-20
Procedures:		
Emergency -----	5-18-5-26	5-14-5-18
Radio -----	1-21, 1-22	1-8
Properties of fire -----	4-5	4-2
Properties of water -----	4-5	4-2
Protection, water -----	4-46a	4-52
Protective clothing -----	2-2, 2-3	2-1, 2-3
Protective devices -----	4-46c	4-53
Pump -----	7-9a	7-12
Pumper drills -----	4-18	4-8
Pumping operations -----	4-36	4-34
Pumper, skid-mounted -----	2-5f	2-8
Pumpers, trailer -----	2-5e	2-7
Pump operator guide plate -----	4-17	4-8
Pump type water extinguishers -----	2-20	2-29
Purple K -----	4-3	4-1
Pyrotechnics -----	5-17	5-13
Quarters:		
Return to -----	4-79	4-80
Sleeping -----	1-11	1-5
Radial engines -----	5-7	5-2
Radio:		
Call procedures -----	1-22d	1-9
Fire department -----	1-21	1-8
Letters -----	1-22c	1-9
Numbers -----	1-22b	1-9
Procedures -----	1-22	1-8
Terms -----	1-22a	1-8
Rail fires -----	6-18	6-6
Raising a victim -----	4-53	4-58
Raising, ladder -----	4-34	4-28
Ram, battering -----	4-39c	4-41
Ranges -----	8-8d	a 3
Rate of water discharge -----	4-9	4-3
Reciprocating engines -----	5-7a	5-2
Records:		
Fire -----	4-78, 4-79	4-80
Hose -----	2-7h	2-11
Technical details of operation and tests -----	1-17	1-7
Use -----	1-15	1-6
Reducing couplings -----	2-8b (3), 2-12b	2-12, 2-21
Reducing wye -----	2-11a	2-20
Removing plaster -----	4-39g	4-46
Replacing a section of hose -----	4-27	4-22
Reports -----	1-17	1-7
Rescue:		
Aircraft -----	5-24	5-17
Carries -----	4-48	4-55
Crash -----	5-24	5-17
Function -----	1-5b	1-2
Operations -----	4-47	4-55
Removing pilot -----	5-26b	5-18
Respiration, artificial -----	4-58, 4-63	4-62, 4-67
Responsibilities:		
Assistant or deputy fire chief -----	1-7b	1-3
Crew chief -----	1-7d	1-4



	Paragraph	Page
Responsibilities-Continued		
Fire chief -----	<b>1-7b</b>	1-3
<b>Firefighters</b> -----	<b>1-7e</b>	1-4
Station chief -----	<b>1-7c</b>	1-4
Return to quarters -----	<b>4-79</b>	4-80
Return to service -----	4-73, 4-79	4-77, 4-80
Reverse lay -----	<b>4-26b</b>	4-20
Rip-rap-load <b>finish</b> -----	<b>4-24b</b>	4-16
Rocker lug -----	<b>2-8e</b>	2-18
Rockets -----	6-16	<b>5-13</b>
Roofs -----	<b>4-39e</b>	4-46
Rope and knots -----	2-16	2-24
Rotating <b>affle</b> valves -----	<b>2-10d</b>	2-20
Safety devices -----	8-10	8-4
Safe storage :		
Ammunition -----	<b>8-16d</b>	<b>8-6</b>
Fire extinguishers -----	<b>8-16a</b>	<b>8-6</b>
Fuels -----	<b>8-16c</b>	<b>8-6</b>
Hose -----	<b>2-7f</b>	2-11
Measures -----	<b>4-48</b>	<b>4-50</b>
Precautions -----	8-16	8-6
Signs -----	<b>6-13, 8-16b</b>	<b>6-3, 8-6</b>
Safety measures, nuclear -----	<b>6-16d</b>	6-4
Salvage :		
Effort -----	<b>1-5b</b> , 4-46	1-2, <b>4-51</b>
Salvage covers -----	<b>4-46b</b>	4-62
Salvage hose -----	<b>2-7g</b>	2-11
Training -----	<b>4-46d</b>	4-64
Sanitation -----	1-13	1-b
Securing ejection seat -----	<b>5-26b</b>	6-18
Self locking donut <b>roll</b> -----	<b>4-19c</b>	4-9
SF Form 46 -----	<b>1-7f</b>	1-4
Shock -----	<b>4-64, 4-65</b>	4-67
Shoulder carry -----	<b>4-30b</b>	<b>4-25</b>
Shoulder harness -----	<b>5-24b</b>	<b>5-17</b>
Shoulder loads -----	<b>4-30b</b>	4-26
Shutoff water <b>signal</b> -----	<b>1-23b</b>	<b>1-9</b>
Siamese :		
Clapper valve -----	<b>2-11b</b>	2-21
Connection -----	<b>2-11b</b>	2-21
Gated -----	<b>2-11b</b>	2-21
Increasing -----	<b>2-11b</b>	2-21
Suction -----	<b>2-11b</b>	2-21
Siamesing -----	<b>4-15</b>	4-6
Signals, hand -----	1-23	<b>1-9</b>
Signs, safety -----	<b>6-13, 8-16b</b>	<b>6-3, 8-6</b>
Size, nozzle -----	4-16, <b>7-9a</b>	4-6, 7-12
Size-up -----	4-38	4-39
Skid-load finish -----	<b>4-24c</b>	4-16
Skid-mounted pumping unit -----	<b>2-5f</b>	2-8
Skylight glass -----	<b>4-39h</b>	4-46
Sleeping quarters -----	<b>1-11</b>	<b>1-5</b>
<b>Slot</b> lug -----	<b>2-8e</b>	2-18
Smoking, cause of fires -----	8-2	8-1
Soda-acid extinguisher -----	2-22	2-30
Sodium chloride dry powder -----	2-27	2-33
Spanner wrench -----	<b>2-8e, 2-14a</b>	2-13, 2-21
Sparks -----	8-4	8-2
Special :		
Nozzles -----	7-7	7-10
Protective clothing -----	2-3	2-3
Splice, eye -----	<b>2-16b</b>	2-24
<b>Splinting</b> -----	<b>4-66c</b>	4-68

	<b>Paragraph</b>	<b>Page</b>
Spontaneous heating -----	<b>3-5a(2)</b>	<b>3-3</b>
Spot fires -----	<b>7-10b</b>	<b>7-18</b>
Sprays -----	<b>8-18</b>	8-7
Sprinkler head -----	<b>2-9g</b>	2-19
Square knot -----	<b>2-16f</b>	2-26
Stacking ammunition -----	<b>7-3a</b>	7-3
Stairway drain -----	<b>4-46c(5)</b>	<b>4-58</b>
Stairway, hose advancing -----	<b>4-26f</b>	4-21
Standard ladders -----	<b>2-15a</b>	2-23
Standpipe pack -----	<b>4-19e</b>	<b>4-9</b>
Static electricity -----	<b>8-15</b>	8-5
Station chief -----	<b>1-7c</b>	<b>1-4</b>
Stations :		
Crash -----	1-10	<b>1-5</b>
Fire -----	1-9	<b>1-5</b>
Structural -----	1-9	<b>1-5</b>
Steampipes		
Storage :		
Ammunition -----	<b>8-16d</b>	<b>8-6</b>
Chart, ammunition -----	<b>7-4a</b>	<b>7-5</b>
<b>Fires</b> -----	<b>6-17</b>	<b>6-5</b>
Fuels -----	<b>8-16c</b>	8-5
Hose -----	<b>2-7f</b>	2-11
Precautions -----	8-16	8-5
Stoves -----	<b>8-8e</b>	8-3
Straight lay -----	<b>4-26a</b>	4-17
Strap, hose -----	<b>4-26e(2)</b>	4-21
Stream, ideal -----	<b>4-13</b>	4-5
Stream straightener -----	<b>2-9f</b>	2-19
Structural stations -----	1-9	<b>1-5</b>
Sun, effects -----	8-6	a-2
Surface fires -----	<b>7-10b(2)</b>	<b>7-18</b>
Switches -----	8-11	<b>8-5</b>
Symbols, explosive -----	<b>6-13</b>	6-3
Systems :		
Alarm -----	1-20, 1-24	<b>1-8</b> , 1-12
Anti-icing -----	6-13	<b>5-13</b>
Electrical -----	<b>5-7a(2), 5-7b(2)</b>	<b>5-2, 5-8</b> ,
	6-12	6-12
Fuel -----	6-9	<b>5-10</b>
Heater -----	6-14	<b>5-13</b>
Heating -----	3-3	8-3
Ignition -----	6-120	<b>5-12</b>
Oil -----	6-10	<b>5-11</b>
Oxygen -----	6-11	<b>5-11</b>
Powerplant -----	6-7, <b>5-12d</b>	6-2, <b>5-13</b>
Telephone -----	1-19	<b>1-7</b>
Ventilation -----	<b>8-8d</b>	<b>8-3</b>
Tactical vehicle fires -----	<b>6-20</b>	<b>6-8</b>
Tactics and techniques of firefighting -----	4-1	4-1
Tail fire -----	<b>7-10a</b>	<b>7-12</b>
Team :		
Brush fire truck -----	<b>1-6d</b>	1-3
Decontamination -----	6-6	6-1
Disposal -----	6-6	6-1
FA team -----	<b>1-6a</b>	1-2
<b>FB team</b> -----	<b>1-6b</b>	<b>1-3</b>
<b>FC team</b> -----	1-50	<b>1-3</b>
<b>FD team</b> -----	<b>1-6d</b>	<b>1-3</b>
Firefighting headquarters -----	<b>1-6a</b>	1-2
Firefighting units -----	1-6	1-2
Fire truck -----	<b>1-6b</b>	<b>1-3</b>
Water truck -----	1-50	1-3

	Paragraph	Page
Techniques of firefighting .....	4-1	41
Telephone systems .....	1-19	1-7
Temperature ignition .....	<b>3-3a</b>	<b>3-1</b>
Terms, radio .....	1-22a	1-8
Tests, hose .....	<b>2-7d</b>	2-11
Timber fires .....	<b>7-11d</b>	7-14
Time factor .....	<b>6-16c</b>	6-4
Time table, training .....	<b>1-17c</b>	1-7
Tools:		
Aircraft rescue, .....	<b>5-7a (5)</b>	6-2
Carrying .....	<b>4-89i</b>	4-47
Coupling .....	<b>2-14c</b>	2-22
Firefighting .....	7-11	<b>7-18</b>
Hose .....	<b>2-14c</b>	2-22
Pioneer .....	<b>7-11a</b>	<b>7-18</b>
Pump .....	<b>7-9a</b>	7-12
Rope .....	<b>2-14b</b>	2-22
Strap, hose .....	<b>4-26e (2)</b>	421
Wrench, hydrant .....	<b>2-14a</b>	2-21
Wrench, spanner .....	2-86, <b>2-14a</b>	2-13, <b>2-21</b>
Tourniquet .....	<b>4-56c</b>	4-61
Traffic pattern .....	<b>5-18</b>	<b>5-14</b>
Trailer-mounted pumping unit .....	2-66	2-7
Trailer pumper .....	<b>2-5e</b>	2-7
Training .....	1-7f, <b>4-46d</b> , 5-21	1-4, <b>4-54</b> , <b>5-15</b>
Training time table .....	<b>1-17c</b>	1-7
Transport vehicle fires .....	6-19	6-6
Transverse hose beds .....	<b>4-21b</b>	412
<b>Triangle, fire</b> .....	3-2	<b>3-1</b>
Trousers, bunker .....	<b>2-2a</b>	2-1
Truckdriver road test .....	1-7f	1-4
Trucks, fire .....	2-6	2-6
Turbine, engine .....	<b>5-7b</b>	5-8
Turbine engine lubricant .....	6-4	6-2
Types of hose .....	<b>2-7a</b>	2-11
Underarm carry .....	<b>4-26d</b>	421
<b>Valve, four-way switch</b> .....	<b>2-11d</b>	2-21
Vapor density .....	<b>3-3c</b>	8-2
Vapors .....	<b>3-3b</b>	a-2
Ventilation:		
Burning building .....	<b>1-5b, 4-44</b>	1-2, <b>4-50</b>
Cross .....	<b>4-44b</b>	461
Systems .....	<b>8-8d</b>	8-8
Vertical .....	<b>4-44a</b>	<b>4-50</b>
Victim, lowering .....	<b>4-53</b>	4-68
<b>View, overall</b> .....	1-6	1-2
Volume of water .....	4-6	4-2
<b>Waste—cause of fires</b> .....	8-8	8-1
Water:		
Application .....	4-11	<b>4-4</b>
Distribution system .....	7-80	<b>7-3</b>
Drafting .....	4-10	4-4
Extinguisher .....	2-20, 2-21	2-29
Pressure .....	4-8	4-8
Properties .....	4-6	4-2
Protection .....	<b>4-46a</b>	462
Rate of discharge .....	4-9	<b>4-3</b>
Thief .....	<b>2-11c</b>	2-21
Volume .....	4-6	4-2
Weight .....	4-7	4-3
<b>Weapon, nuclear</b> .....	6-1	6-1

	<b>Paragraph</b>	<b>Page</b>
Weightofwater -----	4-7	4-3
Window drain chute -----	4-46c	4-53
Windows -----	4-39d	4-44
Winterization of extinguishers -----	2-28	2-34
Wiring -----	8-11	8-5
Wrench:		
Hydrant -----	2-14a	2-21
Spanner -----	2-8e, 2-14a	2-13, 2-21
Wye connections -----	2-11a	2-20
<b>Yield, nuclear</b> -----	6-10	6-3

By Order of the Secretary of the Army :

Official:

**VERNE L. BOWERS,**  
*Major General, United States Army,*  
*The Adjutant General.*

**W. C. WESTMORELAND,**  
*General, United States Army,*  
*Chief of Staff.*

Distribution:

To be distributed in accordance with DA Form **12-25, Sec I** (qty rqr Block **#122**), Organizational maintenance requirements for Fire **Fighting**.