

NELLIS & CREECH AIR FORCE BASES INSTALLATION FACILITIES STANDARDS (IFS)

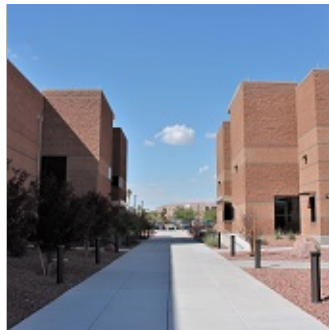

Installation Elements



Site Development

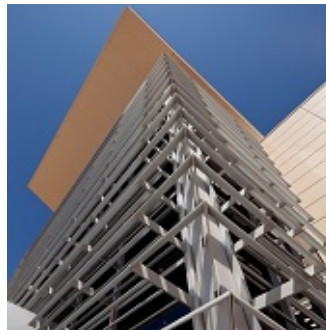

Facilities Exteriors



Facilities Interiors

APPROVED FOR PUBLIC RELEASE; DISTRIBUTION UNLIMITED

Signature Field

Nellis & Creech Air Force Bases IFS

Table of Contents

A. OVERVIEW	5	B03.2.3. Preserves	
A01. Facility Hierarchy	6	B03.2.4. Perimeter Fence	
A02. Facility Quality	6	C. SITE DEVELOPMENT	26
A03. Facility Districts	6	C01. Site Design	26
B. INSTALLATION ELEMENTS	8	C01.1. Site Design Considerations	26
B01. Comprehensive Planning	8	C01.2. Building Orientation	27
B01.1. Installation Development Plan (IDP)	8	C02. Utilities	28
B01.1.1. IFS Component Plan of IDP		C02.1. Utility Components.....	28
B01.1.2. Brief History of Base		C03. Parking Areas	29
B01.1.3. Future Development		C03.1. Configurations and Design	29
B02. Street Envelope Standards	12	C03.1.1. Paving and Striping	
B02.1. Hierarchy of Streets	12	C03.1.2. Curbing	
B02.1.1. Arterial Streets		C03.1.3. Internal Islands and Medians	
B02.1.2. Collector Streets		C03.2. Parking Structures	32
B02.1.3. Local Streets		C03.3. Connectivity	32
B02.1.4. Special Routes		C04. Stormwater Management	32
B02.2. Hierarchy of Intersections	17	C04.1. Stormwater Requirements	33
B02.2.1. Arterials		C05. Sidewalks, Bikeways and Trails	33
B02.2.2. Arterial/Collector		C05.1. Circulation and Paving	34
B02.2.3. Collectors		C05.1.1. Ramps and Stairs	
B02.2.4. Special Intersections		C05.1.2. Lighting	
B02.2.5. Street Frontage Requirements		C06. Landscape	36
B02.2.6. Sight Lines		C06.1. Climate-based Materials	36
B02.3. Street Elements	18	C06.1.1. Landscape Design Concept	
B02.3.1. Paving		C06.1.2. Xeriscape Design Principles	
B02.3.2. Curb and Gutter		C06.1.3. Minimizing Water Requirements	
B02.3.3. Utility Service Elements		C06.1.4. Plant Material Selection	
B02.3.4. Traffic Signs		C06.1.5. Water Budgeting (Hydrozones)	
B02.3.5. Street Lighting		C06.1.6. Base Entrance Landscaping	
B02.3.6. Other		C06.1.7. Streetscape Landscaping	
B03. Open Space / Public Space	20	C06.1.8. Pedestrian Circulation Landscaping	
B03.1. Plazas, Monuments and Static Displays	20	C06.1.9. Parking Lot Landscaping	
B03.1.1. Paved Plazas		C06.1.10. Screen/Accent Landscaping	
B03.1.2. Sculptures, Markers and Statuary		C06.1.11. Other	
B03.1.3. Static Display of Aircraft		C07. Site Furnishings	41
B03.2. Grounds and Perimeters	23	C07.1. Furnishings and Elements	42
B03.2.1. Parade Grounds			
B03.2.2. Parks			

Table of contents continued

C07.2. Site Furnishings Products, Materials / Color ..	43	D03.3.4. Thermal Shading	
C07.2.1. Barbeque Grills		D03.3.5. Renewable Heating/Cooling	
C07.2.2. Benches		D03.3.6. Solar Photovoltaic System	
C07.2.3. Bike Racks		D03.3.7. Solar Thermal System	
C07.2.4. Bike Lockers		D04. Building Entrances	69
C07.2.5. Bollards		D04.1. Primary Entrances	70
C07.2.6. Bus Shelters		D04.2. Secondary Entrances	70
C07.2.7. Drinking Fountains		D05. Wall Systems	71
C07.2.8. Dumpster Enclosures / Gates		D05.1. Hierarchy of Materials	72
C07.2.9. Fencing		D05.2. Layout, Organization and Durability	72
C07.2.10. Flagpoles		D05.3. Equipment, Vents and Devices	73
C07.2.11. Lighting – Landscape / Accent		D05.4 Wall Systems Materials	73
C07.2.12. Litter and Ash Receptacles		D05.4.1. Flat Metal Panels	
C07.2.13. Picnic Tables		D05.4.2. Brick Veneer	
C07.2.14. Planters – Free Standing		D05.4.3. Architectural Precast	
C07.2.15. Play Equipment		D05.4.4. Stucco Over Sheathing	
C07.2.16. Screen Walls		D05.4.5. Curtain Wall	
C07.2.17. Tree Grates		D05.4.6. Cast-in Place Concrete	
C07.2.18. Other		D05.4.7. Tilt-up Concrete	
C08. Exterior Signs	52	D05.4.8. Ribbed Metal Sheeting	
C08.1. Colors and Types	52	D05.4.9. EFIS	
C08.1.1. Materials and Color Specifications		D05.4.10. GRFC	
C08.1.2. Installation and Gate Identification Signs		D05.4.11. Concrete Block	
C08.1.3. Building Identification Signs		D05.4.12. Fiber Cement Siding	
C08.1.4. Traffic Control Devices (Street Signs)		D05.4.13. Other	
C08.1.5. Directional and Wayfinding Signs		D06. Doors and Windows	80
C08.1.6. Informational Signs		D06.1. Types	81
C08.1.7. Motivational Signs		D06.2. Layout and Geometry	81
C08.1.8. Parking Lot Signs		D06.3. Glazing and Shading	81
C08.1.9. Regulatory Signs		D06.4. Hardware	81
C08.1.10. Other		D06.5. Doors and Windows Materials	82
C09. Lighting	58	D06.5.1. Anodized Aluminum	
C09.1. Fixtures and Lamping	59	D06.5.2. Hollow Metal	
C09.2. Light Fixture Types	60	D06.5.3. Aluminum-clad Wood	
C09.2.1. Street Lighting		D06.5.4. Other	
C09.2.2. Parking Lot Lighting		D07. Roof Systems	84
C09.2.3. Lighted Bollards		D07.1. Roof Type and Form	85
C09.2.4. Sidewalk Lighting		D07.2. Roof Slope	85
C09.2.5. Walls / Stairs Lighting		D07.3. Parapets and Copings	85
C09.2.6. Other		D07.4. Color and Reflectivity	86
D. FACILITIES EXTERIORS	61	D07.5. Gutters, Downspouts, Scuppers, Drains	86
D01. Supporting the Mission	61	D07.6. Roof Vents and Elements	86
D02. Sustainability	61	D07.7. Clerestories and Skylights	87
D03. Architectural Features	62	D07.8. Vegetated Roof	87
D03.1. Orientation, Massing and Scale	63		
D03.2. Architectural Character	63		
D03.3. Details and Color	63		
D03.3.1. Climate-based Data			
D03.3.2. Natural Ventilation System			
D03.3.3. Thermal Mass			

Table of contents continued

D07.9. Roof Systems Materials	87	E04. Ceilings	109
D07.9.1. Standing Seam Metal		E04.1. Ceiling Materials	109
D07.9.2. Membrane Single-ply		E04.1.1. Exposed Framing (Roof / Floor Structure	
D07.9.3. Built-up Multi-ply		Above)	
D07.9.4. Concrete Tile		E04.1.2. Exposed Concrete	
D07.9.5. Clay Tile		E04.1.3. Grid and Acoustical Tile	
D07.9.6. Slate Shingles		E04.1.4. Gypsum Board	
D07.9.7. Vegetated System		E04.1.5. Metal Panels	
D07.9.8. Ribbed Metal Sheeting		E04.1.6. Wood	
D07.9.9. Composite Shingles		E04.1.7. Rapidly-Renewable Products	
D07.9.10. Other		E04.1.8. Other	
D08. Structural Systems	91	E05. Doors and Windows	112
D08.1. Systems and Layouts	92	E05.1. Doors and Windows and Frames Materials	112
D08.2. Structural Systems Materials	92	E05.1.1. Aluminum	
D08.2.1. Concrete		E05.1.2. Hollow Metal	
D08.2.2. Insulated Concrete Forming (ICF)		E05.1.3. Wood	
D08.2.3. Steel		E05.1.4. Other	
D08.2.4. Pre-Engineered Steel		E06. Casework Systems	115
D08.2.5. Masonry		E06.1. Casework Materials	116
D08.2.6. Heavy Timber		E06.1.1. Plastic Laminate	
D08.2.7. Light-gauge Steel		E06.1.2. Solid Polymer Surface	
D08.2.8. Lumber Framing		E06.1.3. Rapidly-Renewable Products	
D08.2.9. Other		E06.1.4. Metal	
D09. Mechanical, Electrical and Plumbing	96	E06.1.5 Other	
D09.1. Passive and Active Systems	97	E06.2. Countertop Materials	119
D09.2. Functionality and Efficiency	97	E06.2.1. Plastic Laminate	
E. FACILITIES INTERIORS	98	E06.2.2. Solid Polymer Surface	
E01. Building Configurations	99	E06.2.3. Natural Stone	
E01.1. Layout and Common Areas	99	E06.2.4. Cast Stone	
E01.1.1. Interior Design Process		E06.2.5. Metal	
E01.1.2. Codes and Regulations		E06.2.6 Other	
E01.2. Quality and Comfort	101	E07. Furnishings	121
E02. Floors	101	E07.1. Durability and Serviceability	121
E02.1. Floor Materials	101	E07.2. Accessories	121
E02.1.1. Prepared Slabs		E08. Interior Signs	121
E02.1.2. Natural Stone and Terrazzo		E08.1 Types and Color	121
E02.1.3. Quarry Tile		E08.2. Interior Signs Materials	122
E02.1.4. Ceramic Tile		E09. Lighting, Power and Communication	122
E02.1.5. Resilient Floor		E09.1. Functionality and Efficiency	122
E02.1.6. Carpet		E09.2. Types and Color	122
E02.1.7. Rapidly-Renewable Products		F. Appendices	123
E02.1.8. Other		G. Appendices	123
E03. Walls	106		
E03.1. Wall Materials	106		
E03.1.1. Concrete			
E03.1.2. Masonry			
E03.1.3. Ceramic Tile			
E03.1.4. Gypsum Board			
E03.1.5. Metal Panels			
E03.1.6. Wood Paneling			
E03.1.7. Rapidly-Renewable Products			
E03.1.8. Other			

A. OVERVIEW

Comply with Air Force Corporate Standards for Overview:

<http://afcfs.wbdg.org/index.html>

This Installation Facilities Standards (IFS) document is part of the Air Force Corporate Facilities Standards (AFCFS) program to assist bases in implementing and maintaining facilities standards as appropriate for efficient operations within the respective climate region. IFS fully replaces, consolidates and simplifies existing facilities standards documents, such as the Architectural Compatibility Plan (ACP) or ACGs, FEPs, etc., and organizes information using the same structure, or Table of Contents, as the AFCFS website.

IFS reflects the AFCFS' concepts of "Facility Hierarchy" (categorizing facilities into group numbers) and "Facility Quality" (assigning an appropriate level of quality to each group number) and applies these principles at the base level. Applicable DoD and Air Force criteria such as UFCs, AFIs, Memoranda, and UFGSs (Guide Specs) are referenced and linked within IFS to ensure the document is always current.

Navigating within this IFS is efficient and straightforward. Please use the interactive Table of Contents to locate subject matter, and click on the title of a section to access it. From any page, click on the "Back to Table of Contents" footer to return. Content is organized into 4 major sections: Installation Elements, Site Development, Facilities Exteriors and Facilities Interiors.

This IFS document begins as a fill-in PDF form, which is fully editable, and becomes a "living document" that can be regularly updated by base-level personnel following a format that is consistent across the Air Force. While the format is standardized, IFS content is customized for base operations and the local climate to ensure mission success while emphasizing reduced maintenance and reduced initial costs, life-cycle costs, energy use, and water use.

1. Conformance to Air Force Corporate Facilities Standards (AFCFS) and Installation Facilities Standards (IFS) are required by Air Force Instruction (AFI) 32-1023 and Air Force Memorandum. Please refer to the AFCFS website for links to documentation on current policy.
2. Requests to deviate from any installation facilities standards, that are Unified Facilities Criteria (UFC) requirements, will follow the process outlined in the AFCFS for UFC waivers and exemptions.
3. The IFS is a component plan of the Installation Development Plan (IDP) per Air Force Instruction (AFI) 32-7062 (replacing the Architectural Compatibility Plan). All military construction projects and Non-Appropriated Funds (NAF) facilities are required to comply with the IDP and its IFS component plan by AFI 32-1023. The Base Civil Engineer (BCE) maintains and implements the IDP and its component plans, to include the IFS.
4. Please refer to the AFCFS website as a portal to reference materials and requirements documents for design and construction projects (via links). Specific references to current DoD memoranda and Air Force criteria are updated periodically to provide the most current guidance and requirements. Programming, design and contract documents should list "current edition" for all reference and requirements documents. The documents in force at the date of execution of the design and/or construction contract shall be the governing version.
5. *Advanced Modeling Requirements:*
For all Air Force projects requiring advanced modeling, to include 3D visualization, Building Information Modeling (BIM), facility data, quantity take-off, geospatial, etc., follow the Army standards. Refer to USACE Minimum Model Matrix (M3) and Project Execution Plan (PxP) which outline required model uses. Refer to [CAD BIM Technology Center \(Contract Requirements\)](#) for more information on M3 and PxP.
6. Joint Bases shall implement IFS under their Joint-Base designation with volume numbers for individual installations following the IFS Development Tool template. For example, for Joint Base Langley-Eustis, provide: Vol. 1 Langley AFB and Vol. 2 Fort Eustis.
7. References and Supplementary Documents listed in Appendix G are included in these Installation Facilities Standards by reference and are fully part of this document. Please refer to [Appendix G](#) for a listing of documents, which are available via hyperlink for viewing and downloading.



Nellis AFB and Las Vegas Valley

A01. FACILITY HIERARCHY

Comply with AF Corporate Standards for Facility Hierarchy (and subsections):
<http://afcs.wbdg.org/facility-hierarchy/index.html>

A02. FACILITY QUALITY

Comply with AF Corporate Standards for Facility Quality (and subsections):
<http://afcs.wbdg.org/facility-quality/index.html>

A03. FACILITY DISTRICTS

Comply with AF Corporate Standards for Facility Districts (and subsections):
<http://afcs.wbdg.org/facility-districts/index.html>

Image Tool 800 x 800

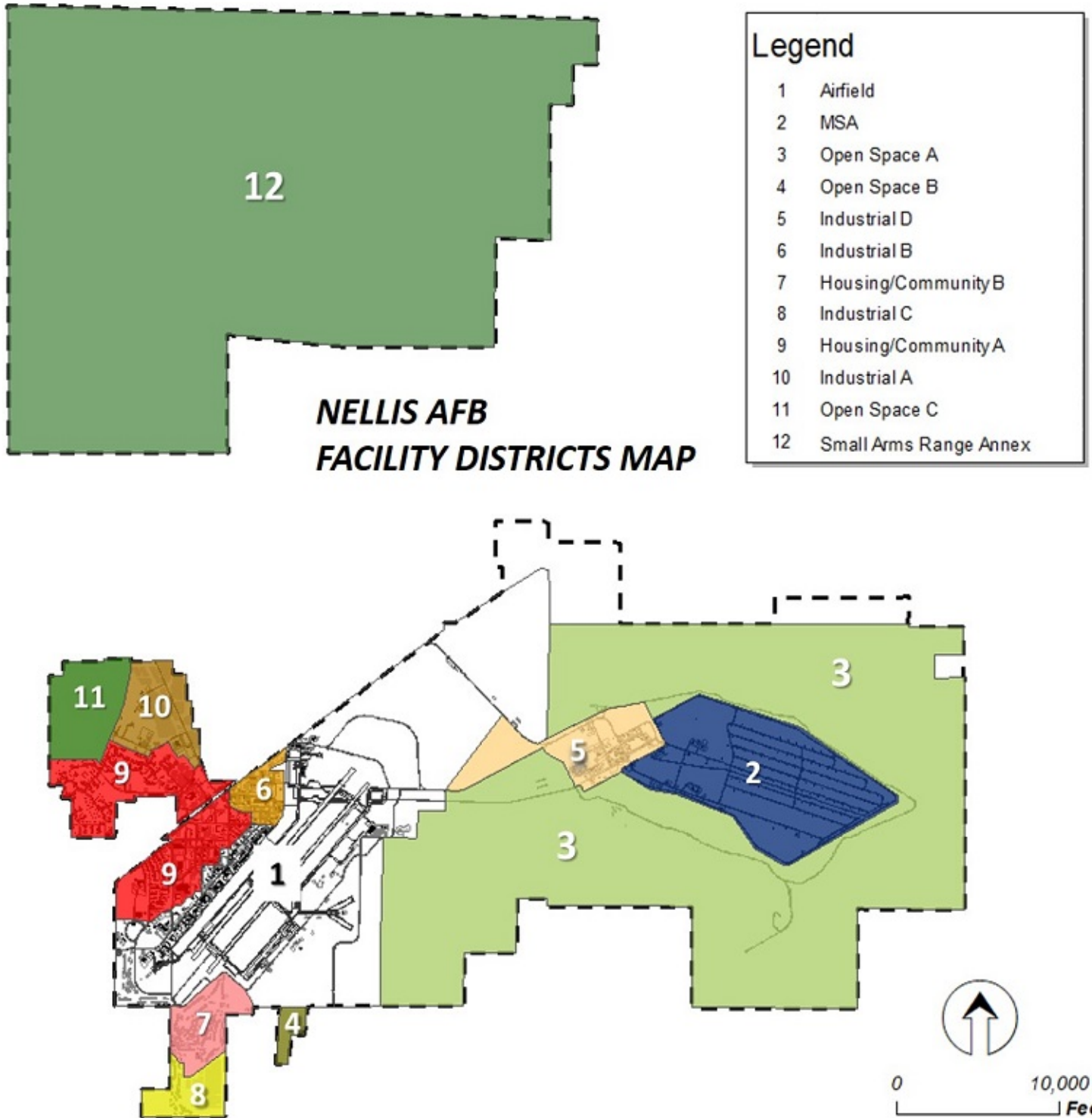

Note: Apply the base-wide standards in this IFS for Installation Elements, Site Development, Facilities Exteriors and Facilities Interiors (products, materials, color, etc.). Following application of the base-wide standards, refer to the Appendix and apply any additional requirements specifically related to the Facility District.

B. INSTALLATION ELEMENTS

Comply with Air Force Corporate Standards for Installation Elements:

<http://afcs.wbdg.org/installation-elements/index.html>

B01. COMPREHENSIVE PLANNING

Comply with Air Force Corporate Standards for Comprehensive Planning:

<http://afcs.wbdg.org/installation-elements/comprehensive-planning/index.html>

B01.1. Installation Development Plan (IDP)

Applicable N/A Select number of graphics / images (large: 800 px x 440 px) to insert 1

Image Tool 800 x 440

Applicable N/A Small graphics do not apply

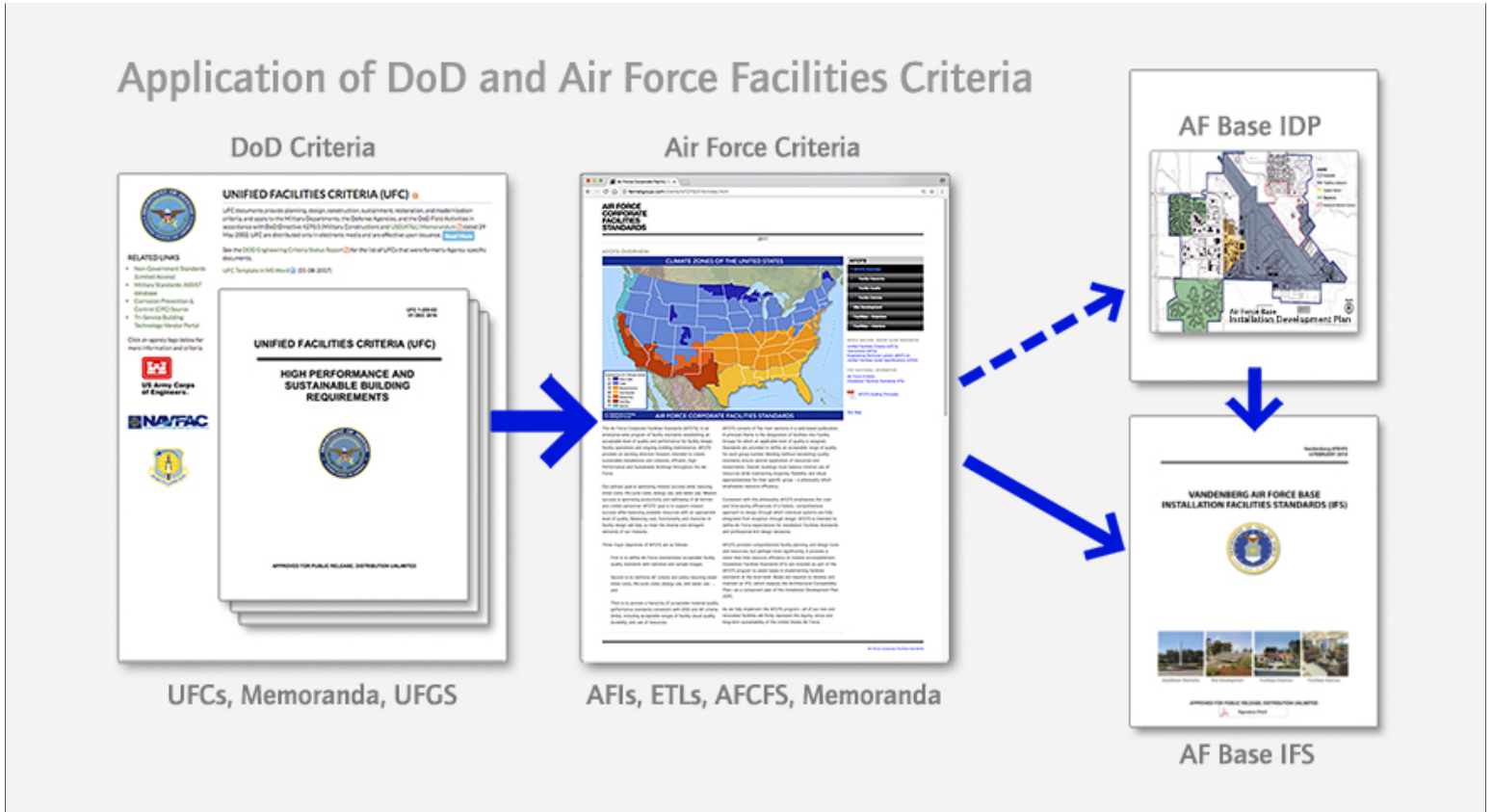

Department of Defense, Department of the Air Force and Air Force Base Criteria

1. The Base Civil Engineer is responsible for developing, maintaining and implementing the installation's Comprehensive Planning documents and to ensure that the Installation Development Plan (IDP) is prepared, maintained, and implemented following AFI 32-7062.

B01.1.1. IFS Component Plan of IDP

Applicable N/A Large graphics do not apply

Applicable N/A Small graphics do not apply

B01.1.2. Brief History of Base

Applicable N/A Large graphics do not apply

Applicable N/A Select number of graphics / images (small: 250 px x 188 px) to insert 3

Image Tool 250 x 188



Las Vegas Army Air Field 1941



Nellis AFB 1956



Nellis AFB and USAF Thunderbirds 1958

In 1929 Las Vegas Airport opened eight miles northeast of downtown Las Vegas. In 1932, the airfield was purchased by Western Air Express, which carried passengers in between Los Angeles and Salt Lake City. The U.S. Army surveyed the field in 1940 for use as the Army Air Forces Flexible Gunnery School due to the good flying weather throughout the year, nearby vacant land for gunnery ranges, and being located away from the Pacific Ocean's coastline. After the survey was completed, the city of Las Vegas purchased the airfield on Jan. 2, 1941 for \$10. The U.S. Army leased the airfield three days later. In October 1941, the airfield was dedicated as the Las Vegas Army Air Field. Aircraft assigned to present day Nellis have "WA" tail code which represents Western Air.

Starting in 1942, gunnery training at Las Vegas Army Air Field commenced with student gunners progressing from skeet shooting from atop moving vehicles to mobile sperry ball turrets and stationary top turrets for the B-17 Flying Fortress, and by 1945 for the B-29 Superfortress. The training produced approximately 55,000 B-17 and 3,500 B-25 Mitchell gunners for World War II. From July to August 1942, a training film called "The Rear Gunner" which starred Ronald Reagan and Burgess Meredith, was produced at Las Vegas Army Air Field to generate military flying volunteers.

Operations at the base wound down after World War II came to an end which ultimately put the base in stand-by status in December 1946. The base re-opened in January 1949 for advanced pilot training with the first gunnery meet and the opening of the Aircraft Gunnery School in May 1949. On May 1, 1950, Las Vegas Army Air Field was officially renamed Nellis Air Force Base, after the late 1st Lt. William Nellis, a southern Nevadan who was shot down while flying during the Battle of the Bulge. Many of the Korean War aces trained at Nellis AFB or served as instructors after their combat tours. Later in 1950, Nellis AFB opened its first base chapel and a movie theatre, which provided Airmen an escape from the base's mission during their off-duty time. The airfield was expanded between 1951 -1954 with longer jet-capable runways, reconfigured taxiways, and a larger aircraft parking ramp. In the 1950s World War II era wooden structures were replaced with concrete and steel structures. In 1956, the Air Force's official air demonstration team was assigned to Nellis AFB and is formally known as the U.S. Air Force Air Demonstration Squadron, the Thunderbirds.

Today, Nellis AFB and the U.S. Air Force Warfare Center, having the world's largest and most demanding advanced air combat training mission, help crews learn to be the best combat aviators in the world. Nellis AFB hosts many diverse missions and operations that include Red Flag, Green Flag, the Thunderbirds, and the U.S. Air Force Weapons School. All contribute to the "Home of the Fighter Pilot" mission of "Testing, Training, and Tactics." Nellis provides advanced combat training on every type of aircraft in the Air Force inventory for composite strike forces. Training is commonly conducted in conjunction with air and ground units of the Army, Navy, Marine Corps, and air forces from allied nations. Nellis conducts operational testing and evaluation in addition to supporting combat search and rescue and unmanned aircraft system operations worldwide. Nellis AFB covers more than 14,000 acres and is home to approximately 15,000 military and civilian personnel. The larger "Nellis Air Force Base Complex" military region includes Creech Air Force Base and the 4,700 square mile Nevada Test and Training Range (NTTR).

B01.1.3. Future Development

Applicable N/A Select number of graphics / images (large: 800 px x 440 px) to insert 3

Image Tool 800 x 440

Applicable N/A Small graphics do not apply



Nellis AFB, Area I and Area III, 2018



Crech Air Force Base 2018

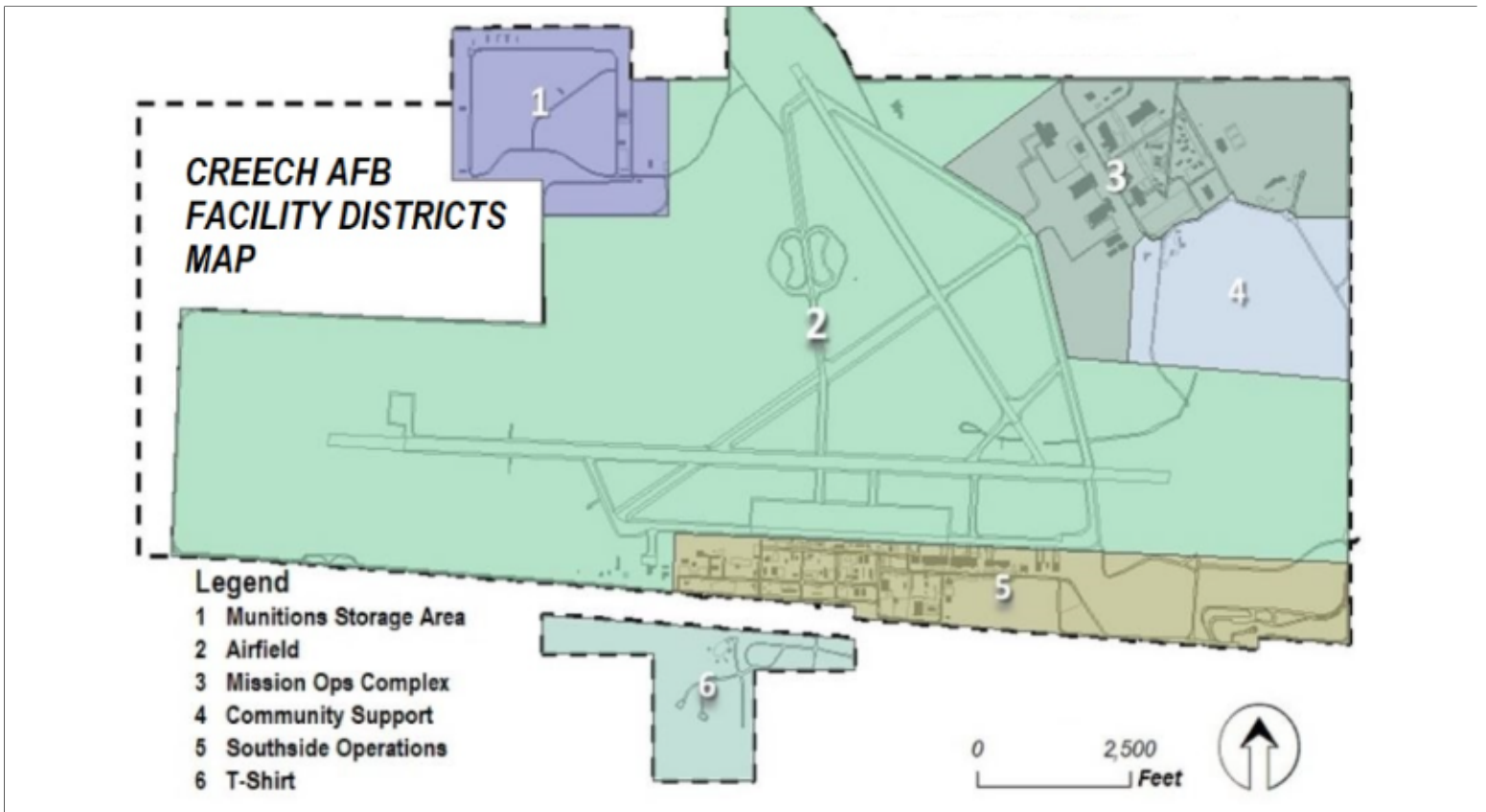

1. Follow AFI 32-7062 for Air Force Comprehensive Planning, the Comprehensive Planning Process, Comprehensive Planning Requirements, and Geospatial Mapping.

2. Address all future development under the Installation Development Plan (IDP).

B02. STREET ENVELOPE STANDARDS

Comply with Air Force Corporate Standards for Installation Elements:

<http://afcs.wbdg.org/installation-elements/index.html>

Comply with AF Corporate Standards for Street Envelope Standards:

<http://afcs.wbdg.org/installation-elements/street-envelope-standards/index.html>

B02.1. Hierarchy of Streets

Applicable N/A Select number of graphics / images (large: 800 px x 440 px) to insert 1

Image Tool 800 x 440

Applicable N/A Select number of graphics / images (small: 250 px x 188 px) to insert 3

Image Tool 250 x 188



Nellis AFB, Main Base Area and Flightline

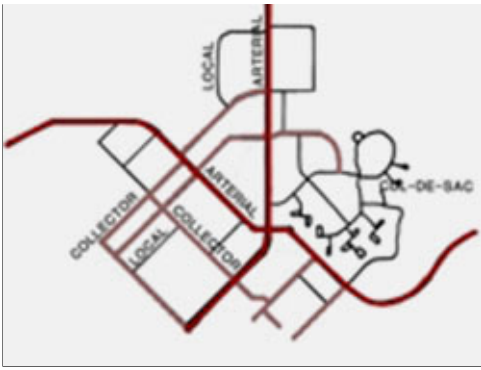

Hierarchy of Streets

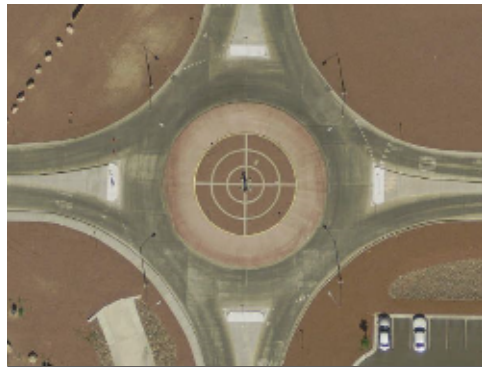

Roundabout



Arterial Street

1. Develop and evolve a hierarchical transportation network of arterial, collector and local streets following UFC 3-201-01 and its industry references.
2. Provide consistent functionality throughout the installation and a level of visual quality relating to the adjacent Facility Group number.
3. Routes along facilities in Group 1 may have materials, finishes and features with a higher visual quality than Groups 2, 3 and 4. Reduce maintenance requirements by installing highly durable materials and finishes in routes along Group 3 industrial facilities.
4. Special routes may have a visual quality comparable to those along facilities in Group 1.
5. Create and maintain arterials with two lanes of traffic in each direction with landscaped or paved medians as applicable to the desert climate and adjacent facility group designation / land use.
6. Minimize stops and turns along arterials. Eliminate on-street parking along arterials and collector streets.
7. Connect arterials to local streets with appropriately scaled collector streets.
8. Provide appropriate landscape setbacks and pedestrian buffers along all streets.
9. Minimize and consolidate curb cuts along streets.
10. Ensure access for emergency and service vehicles.
11. Define bicycle traffic routes in the Installation Development Plan or its applicable component plans.

B02.1.1. Arterial Streets

Applicable N/A Select number of graphics / images (large: 800 px x 440 px) to insert 1

Image Tool 800 x 440

Applicable N/A Select number of graphics / images (small: 250 px x 188 px) to insert 3

Image Tool 250 x 188

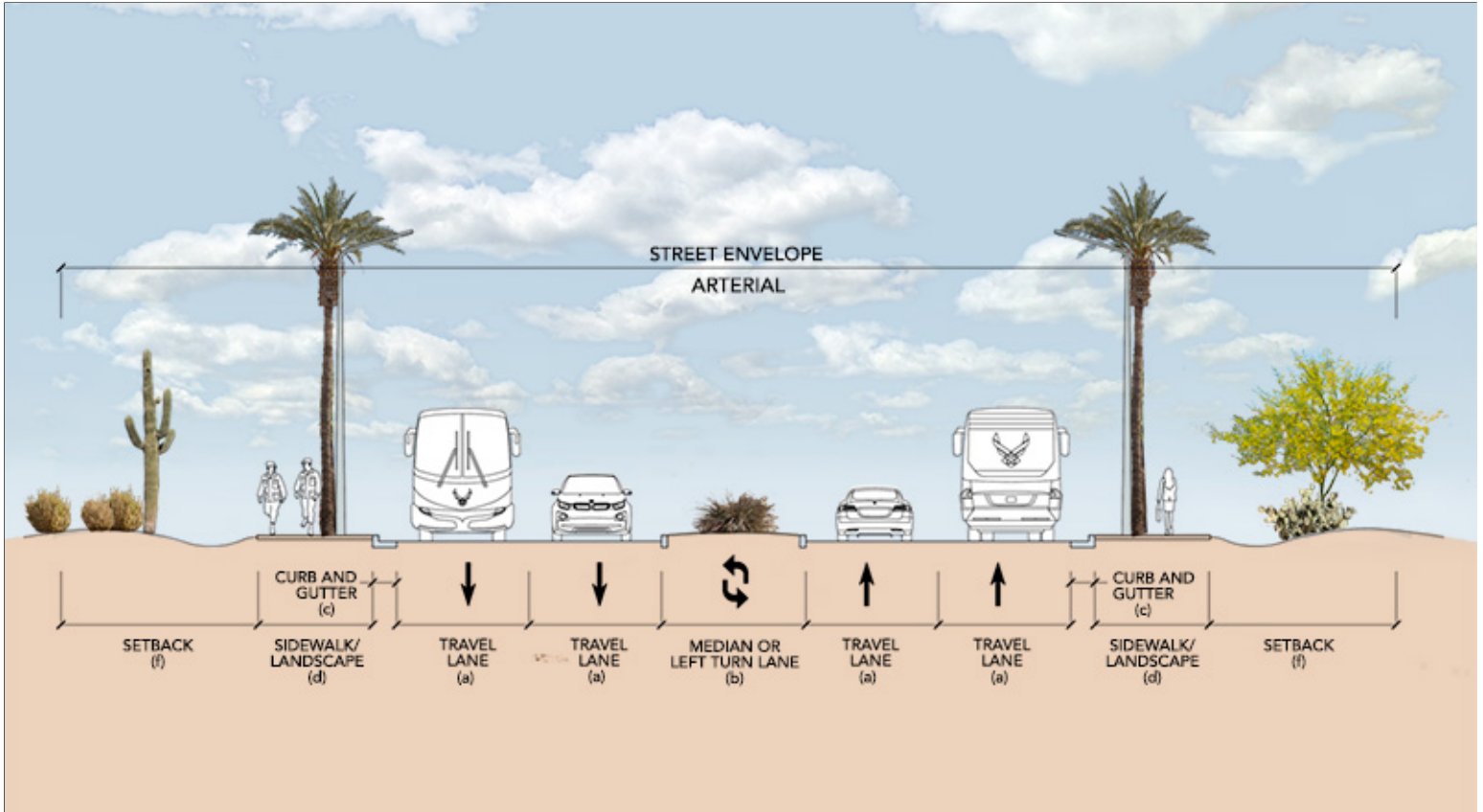

Travel Lane (a): 12' Median (b): 12' Curb and Gutter (c): 2' Sidewalk / Landscape (d): 12' Setback (f): Min. 30' or per ATFP

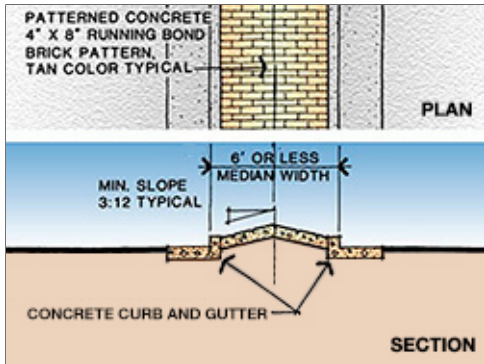

Paved Median



Arterial Street



Roundabout

1. Stops and turns should be minimized and on-street parking shall not be allowed at any point along arterial streets.
2. Provide sidewalks on at least one side of arterial streets and both sides of arterial streets in developed areas. Provide a 6 foot buffer between the road and sidewalk where space allows.
3. Limit curb cuts on arterial streets to entries into major facilities, building groups and major parking areas.
4. Reinforce the importance of arterial streets with appropriate signs, plantings and street lighting.

B02.1.2. Collector Streets

Applicable N/A Select number of graphics / images (large: 800 px x 440 px) to insert 1

Image Tool 800 x 440

Applicable N/A Small graphics do not apply

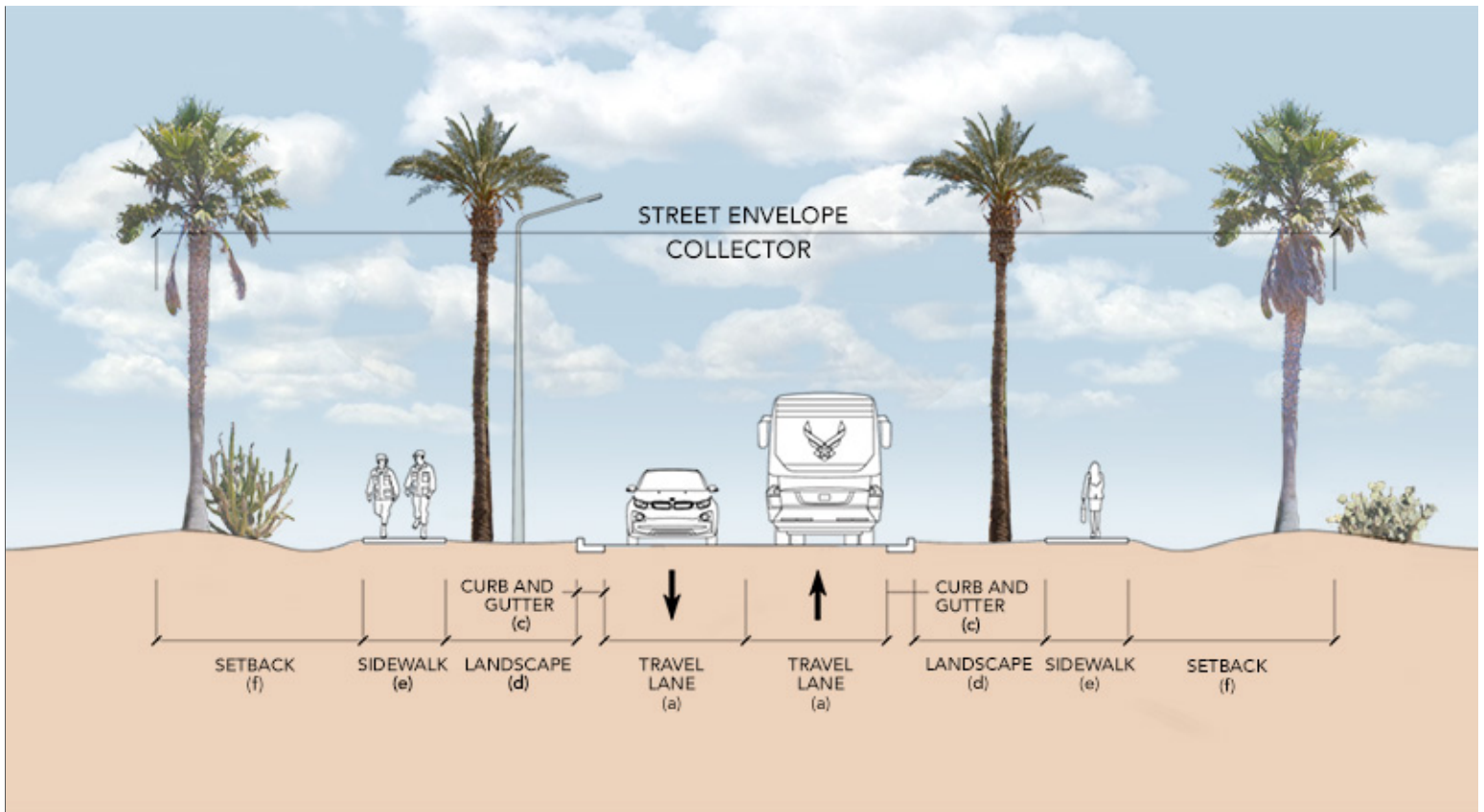

Travel Lane (a): 12' Median (b): N/A Curb and Gutter (c): 2' Landscape (d): 10' Sidewalk (e): 6' Setback (f): Min. 30' or per ATFP

1. Frequent traffic stops and low speeds are permitted on collector streets.
2. Provide sidewalks on at least one side of collector streets and both sides of collector streets where functionally required. Buffers are preferred but not required on collector streets.
3. On street parking may be allowed on one side where secondary roads are over 28 feet wide but not less than 34 feet wide. Parking shall not interfere with intersections or traffic flow.
4. Signs, plantings and street lighting should reinforce the designation of "collector" street.

B02.1.3. Local Streets

Applicable N/A Select number of graphics / images (large: 800 px x 440 px) to insert 1

Image Tool 800 x 440

Applicable N/A Small graphics do not apply

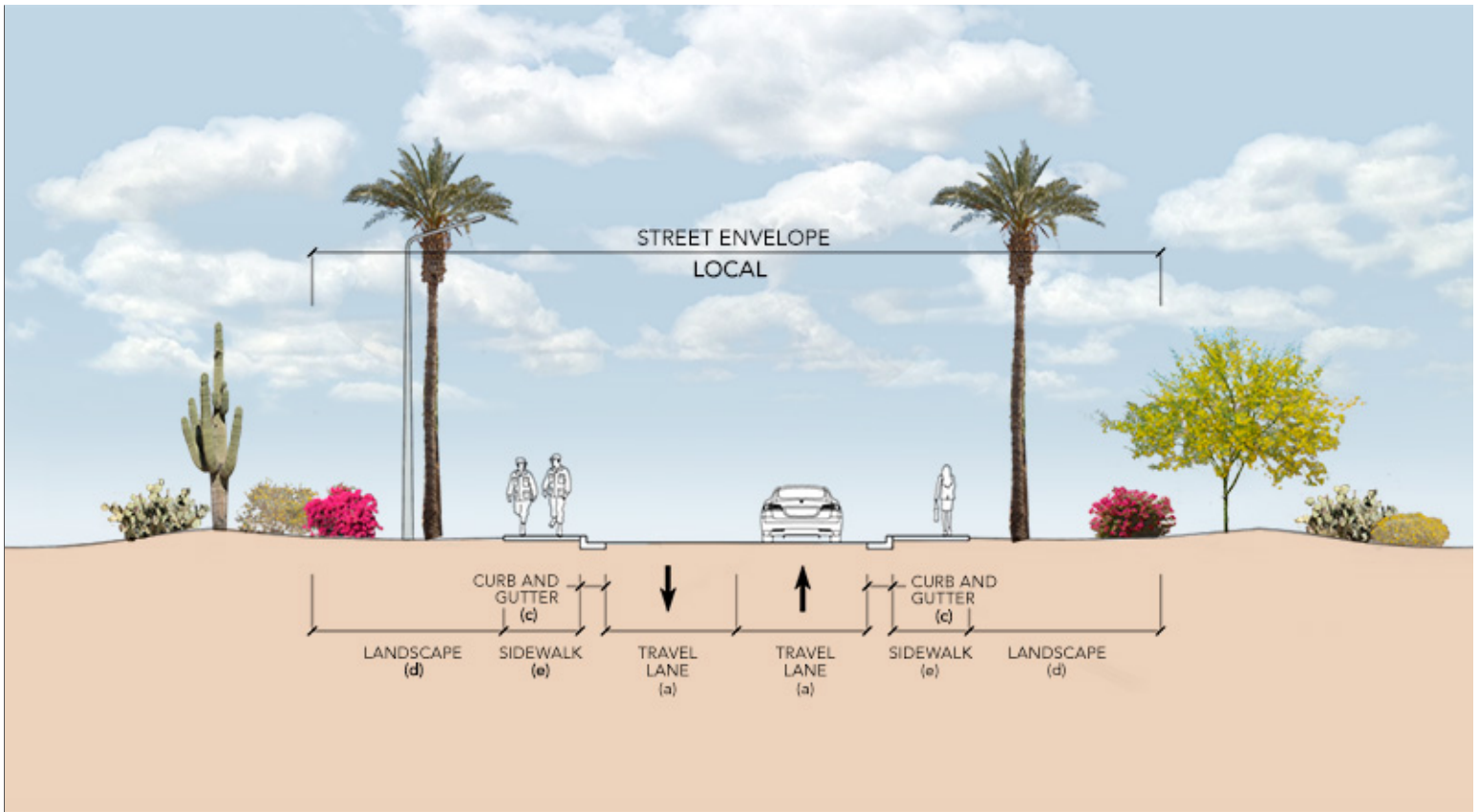

Travel Lane (a): 11' Median (b): N/A Curb and Gutter (c): 1.5' Landscape (d): 15' Sidewalk (e): 6'

1. Frequent traffic stops and low speeds are permitted on local streets.
2. Provide sidewalks on both sides of local streets where functionally required.
3. On street parking may be allowed following UFC industry references.
4. Signs, plantings and street lighting should reinforce the designation of "local" street.
5. Cul-de-sacs are only permitted in family housing areas.

B02.1.4. Special Routes

Applicable N/A Large graphics do not apply

Applicable N/A Small graphics do not apply

1. Develop all special routes consistently with those adjacent to Group 1 facilities.

B02.2. Hierarchy of Intersections

Applicable N/A Large graphics do not apply

Applicable N/A Small graphics do not apply

1. Provide a hierarchy of intersections to include arterial, arterial-collector, collector, collector-local and local following UFC 3-201-01 and its industry references.
2. Passive systems such as roundabouts are preferred to active systems such as signalized intersections. Aggressively pursue passive systems to lower maintenance requirements and reduce energy use.
3. Use a level of visual quality for an intersection equal to the quality found in the related streetscape, which corresponds to the adjacent Facility Group number.

B02.2.1. Arterials

Applicable N/A Large graphics do not apply

Applicable N/A Small graphics do not apply

1. Provide an informal grouping of low lying shrubs with trees as a backdrop at all four corners. Accent boulders and rock mulch may be appropriate. Monument walls with signage are appropriate adjacent to Group 1 facilities. Maintain appropriate sight lines at all intersections.

B02.2.2. Arterial/Collector

Applicable N/A Large graphics do not apply

Applicable N/A Small graphics do not apply

1. Provide an informal grouping of low lying shrubs with trees as a backdrop where appropriate. Accent boulders and rock mulch may also be appropriate. Maintain appropriate sight lines at all intersections.

B02.2.3. Collectors

Applicable N/A Large graphics do not apply

Applicable N/A Small graphics do not apply

1. Provide an informal grouping of low lying shrubs with trees as a backdrop where appropriate. Accent boulders and rock mulch may also be appropriate. Maintain appropriate sight lines at all intersections.

B02.2.4. Special Intersections

Applicable N/A Large graphics do not apply

Applicable N/A Small graphics do not apply

1. Develop all special intersections consistently with those adjacent to Group 1 facilities.

B02.2.5. Street Frontage Requirements

Applicable N/A Large graphics do not apply

Applicable N/A Small graphics do not apply

1. Consistently maintain open space buffers following B03.2.3. Preserves.
2. Refer to C06.1.7. Streetscape Landscaping for planting and screen wall requirements along street frontage.

B02.2.6. Sight Lines

Applicable N/A Large graphics do not apply

Applicable N/A Small graphics do not apply

1. Provide adequate sight lines for an effective and safe traffic operation per American Association of State Highway and Transportation Officials (AASHTO) standards and Clark County guidelines.
2. Maintain a 45 foot clear zone free of visual barriers over 18 inches in height at uncontrolled intersections. Maintain a 15 foot clear zone free of visual barriers over 18 inches in height at controlled intersections with vehicle speeds of 30 mph or less.

B02.3. Street Elements

Applicable N/A Large graphics do not apply

Applicable N/A Small graphics do not apply

1. Emulate the streetscape area's pre-development hydrology using passive and active design features to help sustain the adjacent desert or xeriscape landscape. Coordinate with the base Stormwater Management Plan.
2. Employ systems, materials and techniques to maximize streetscape sustainability. Consider pervious paving and high reflectivity of surfaces, appropriate for the desert climate.
3. Install raised-profile curb and gutter to direct stormwater to drainage swales that connect to retention / detention basins. Provide 2 ft. wide curb cut at drainage swale location. Do not paint concrete curbing.
4. Provide all on-site utility service lines and equipment below grade when adjacent to Facility Group 1. In routes along Group 2, 3 and 4, when mounting elements such as utility cabinets, communications equipment and water valves above grade is unavoidable, paint these consistently and provide visual screening following Installation Facilities Standards (IFS).
5. Provide traffic control devices including access control point/entry control facility signs, speed limit signs and street name signs following the current edition of the Manual on Uniform Traffic Control Devices (MUTCD) per UFC 3-120-01.
6. Lane delineation in all streets shall be appropriately sized and colored ceramic traffic buttons and reflectors. Painted lines shall not be installed.
7. Crosswalk markings shall follow the MUTCD for Streets and Highways, current edition. Provide white markings that define the crosswalk. Markings shall be durable and low maintenance.
8. Follow Clark County Public Works and Nevada Dept of Transportation (NDOT) standards for all street elements.
9. Follow UFC 3-120-01 for directional and wayfinding signs and address both vehicular and pedestrian traffic.

10. Reduce energy consumption and reduce maintenance requirements by providing street lighting only when functionally required to ensure safety and to address antiterrorism following UFC 4-010-01. Ensure the quality and quantities of lighting and fixtures are appropriate for the adjacent Facility Group number.

B02.3.1. Paving

Applicable N/A Large graphics do not apply

Applicable N/A Small graphics do not apply

1. Pavement design shall comply with UFC 3-250-01. Ensure appropriate analysis and design of subgrade conditions to promote low maintenance, high performance pavements. Apply all applicable best practices from Appendix B of the UFC.
2. Materials shall be specified in accordance with UFC 3-250-01 and must conform to requirements set forth in the Unified Facility Guide Specifications (UFGS) for concrete and bituminous pavement.
3. Underground utility lines: Lateral boring shall be used where possible to eliminate road and parking lot cuts. Trenches cut in asphalt pavement shall be backfilled with slurry cement to prevent settlement. Install spare conduit or sleeve in trench for future needs where possible. Pavement patches shall have a minimum width of 15 ft. plus actual width of trench.

B02.3.2. Curb and Gutter

Applicable N/A Large graphics do not apply

Applicable N/A Select number of graphics / images (small: 250 px x 188 px) to insert 3

Image Tool 250 x 188

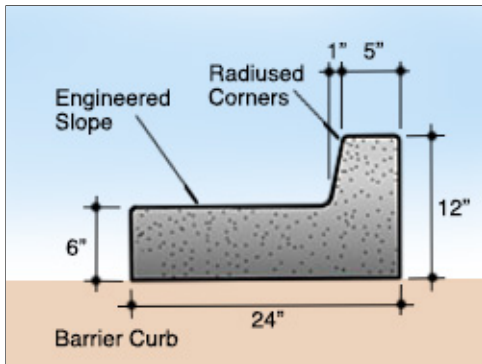

Barrier Curb

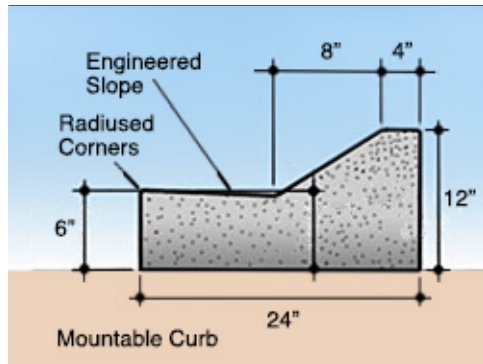

Mountable Curb



Street Curb and Gutter

1. Curb all streets except remote/isolated roads and rock-paved service roads.
2. All streets should have integral concrete curbs and gutters. Painted curbs are prohibited due to required maintenance.
3. Use concrete for sidewalks and curbs. Do not use asphalt curbs.

B02.3.3. Utility Service Elements

Applicable N/A Large graphics do not apply

Applicable N/A Small graphics do not apply

1. Provide all utility service lines below grade when streets are adjacent to Facility Group 1.

2. When mounting elements (such as utility cabinets, communications equipment and water valves) above grade is unavoidable, paint these consistently and provide visual screening following Site Development, Landscaping.
3. Overhead service lines along streets adjacent to Facility Groups 2, 3 and 4 are discouraged.

B02.3.4. Traffic Signs

Applicable N/A Large graphics do not apply

Applicable N/A Small graphics do not apply

1. Refer to Exterior Signs, Colors and Types for Traffic Control Devices, which includes signs.

B02.3.5. Street Lighting

Applicable N/A Large graphics do not apply

Applicable N/A Small graphics do not apply

1. Refer to the Lighting section for appropriate applications along streets.

B02.3.6. Other

Applicable N/A Large graphics do not apply

Applicable N/A Small graphics do not apply

B03. OPEN SPACE / PUBLIC SPACE

Comply with Air Force Corporate Standards for Installation Elements:

<http://afcs.wbdg.org/installation-elements/index.html>

Comply with AF Corporate Standards for Open Space / Public Space:

<http://afcs.wbdg.org/installation-elements/open-space-public-space/index.html>

B03.1. Plazas, Monuments and Static Displays

Applicable N/A Large graphics do not apply

Applicable N/A Small graphics do not apply

1. Natural features and culturally or historically significant features or events may be recognized and acknowledged with physical elements such as plazas, monuments and static displays. However, limit these elements on the base to ensure judicious use of resources and to reduce ongoing maintenance requirements.
2. Design highly durable plazas, monuments and static displays with a level of quality comparable to Facility Group 1.
3. Link plazas, monuments and static displays to the pedestrian circulation system. Install landscaping, site furnishings and lighting appropriate for the application and desert climate following Installation Facilities Standards (IFS).
4. Select systems, products and materials for paving, walls, and structures following IFS.

B03.1.1. Paved Plazas

Applicable N/A Large graphics do not apply

Applicable N/A Select number of graphics / images (small: 250 px x 188 px) to insert 3

Image Tool 250 x 188



Colored Concrete Paving



Accent Colored Paving



Natural Concrete

1. Mitigate heat island by providing high-albedo, shaded plazas. Pervious pavers shall be used on all plazas and courtyards in Facility Groups 1 and 2; use pervious concrete in Groups 3 and 4. The designer shall incorporate appropriate expansion and construction joints.
2. Pavers shall match the color of pavers used on adjacent sidewalks using base standard range of earth tone colors. Pavers used on plazas shall typically be 4" x 8" size or larger.

B03.1.2. Sculptures, Markers and Statuary

Applicable N/A Large graphics do not apply

Applicable N/A Select number of graphics / images (small: 250 px x 188 px) to insert 3

Image Tool 250 x 188



Ground Mounted Aircraft Display



Bronze Plaque



Ground Mounted Vehicle Display

1. Relate new sculpture, markers and statuary to the base's architectural design theme. Generally limit these elements to frequently used locations adjacent to Facility Group 1 and highly traveled community pedestrian spaces.
2. Consider entry gates as possible sites for new displays.
3. All proposed memorials shall follow AFI 36-3108 and be limited to highly deserving individuals or groups as deemed appropriate by the installation leadership. Living memorials (tree plantings / etc.) are discouraged due to added maintenance requirements.

4. When sculpture requires a base, match the materials and / or color palette of adjacent buildings.
5. Use direct or indirect lighting to accentuate features or enhance an intended effect.
6. Ensure that all sculpture, markers and statuary are honorable and inspiring, provide a sense of place, positively contribute to the base's visual quality, and encourage pride for the community and the US Air Force.
7. All displays shall be sited and approved by BCE office. Unit specific motivational/moral displays are prohibited but may be approved on a case basis by BCE office.

B03.1.3. Static Display of Aircraft

Applicable N/A Large graphics do not apply

Applicable N/A Select number of graphics / images (small: 250 px x 188 px) to insert 6

Image Tool 250 x 188



Dynamic Mounting



Dramatic Cantilever Mount



Post Mounted Displays



Park Setting



Entrance Plaza Setting



Streetscape Setting

1. Follow IFS base-wide standards for all elements of the display area with specific attention to traffic sight lines, pedestrian circulation, site furnishings, signs, and lighting. Address requirements for the Facility District as well.
2. Generally locate concrete base/foundation structures for static displays below grade.
3. At static displays where pedestrian paths are provided, a minimum of one trash receptacle and one bench shall be provided. Receptacle and bench design must conform to IFS requirements.

B03.2. Grounds and Perimeters

Applicable N/A Large graphics do not apply

Applicable N/A Small graphics do not apply

1. Provide formal spaces for parade and review functions, recreational areas and parks following the base's Installation Development Plan (IDP) and Installation Facilities Standards (IFS). Refer to the Site Furnishings topic for additional information.
2. Maintain preservation areas following the IDP and IFS.
3. Comply with UFC 4-010-01 DoD Minimum Antiterrorism Standards for Buildings and UFC 4-022-03 Security Fences and Gates for all elements associated with the base's gates and perimeter fence.
4. Identify and describe base-wide utility corridors in the IDP.
5. Base-wide utility infrastructure shall be inconspicuous. Bury utility service lines below grade when adjacent to Facility Group 1 and when economically feasible for Facility Groups 2, 3 and 4. When service lines are located above grade, create an ordered, coordinated appearance.
6. Follow the requirements of this IFS regarding all utility structures and service lines located above grade that visually impact the installation.
7. Where screening of utility equipment and structures is provided, allow adequate and proper clearance for safety and maintenance.
8. Reduce visual clutter and visual impact of the following items through a combination of careful placement, screen walls, landscaping and painting:
 - Electrical switch-stations
 - Sewage lift stations
 - Water well pumps, storage tanks and/or related structures
 - Gas piping, conduit, meters and similar incidental items
 - Above ground fuel storage tanks
 - Any ground-mounted freestanding utility item exposed to view
9. Larger structures such as electrical switch-stations, sewage lift stations, fuel storage tanks and mechanical/electrical equipment shall be screened from view, using materials, forms, and colors in the screen walls which match those respective design elements present at adjacent buildings.
10. All above-ground equipment and associated components such as electrical conduit, boxes, or exposed plumbing lines shall be painted Sierra Tan color.
11. Maintain currently buried utility service lines as a visual asset.
12. Bury the following exposed above-grade items in future projects when economically feasible:
 - Electrical power grid and service lines
 - Telephone lines
 - Cable TV lines
 - Communications lines
 - Exterior lighting service lines
 - Any similar system of above-ground lines serving the base
13. Consolidate and enclose service utility lines in underground utility corridors when feasible. Create routes along the inside edge of parking lot islands.

B03.2.1. Parade Grounds

Applicable N/A Large graphics do not apply

Applicable N/A Small graphics do not apply

B03.2.2. Parks

Applicable N/A Select number of graphics / images (large: 800 px x 440 px) to insert 1

Image Tool 800 x 440

Applicable N/A Small graphics do not apply



Recreation Field Being Used for Base Community Function

1. Permanent bleachers may be installed only when there is a documented requirement at parks and fields for recreational events. Nonferrous metals that do not require painting or ongoing maintenance are preferred. The Base Civil Engineer (BCE) office shall determine quantities, sizes, and products on a case basis. Pavement shall be provided under bleachers
2. Picnic pavilions and shade structures may be provided in parks and recreation areas where there is a documented need.

B03.2.3. Preserves

Applicable N/A Large graphics do not apply

Applicable N/A Small graphics do not apply

1. Preserve areas adjacent to runways, taxiways, aprons, golf course roughs, storage areas, antenna facilities, and ammunition storage areas, as open space.
2. Minimal ground maintenance should be required to control bird behavior for airfield safety or to eliminate fire, safety or security hazards.

B03.2.4. Perimeter Fence

Applicable N/A Large graphics do not apply

Applicable N/A Small graphics do not apply

1. Design, install and maintain the base's perimeter fence following UFC 4-022-03.
2. Stringently comply with ATFP requirements following UFC 04-010-01 for all spaces adjacent to the base's perimeter fence and all gates.
3. Fencing, gates and other elements that are associated with the main gates shall be a level of quality equivalent to Facility Group 1.
4. Maintain a positive visual quality along the traffic corridor on both sides of the main gates. Specifically address pedestrian access, circulation and common areas.

C. SITE DEVELOPMENT

Comply with Air Force Corporate Standards for Site Development:
<http://afcs.wbdg.org/site-development/index.html>

C01. SITE DESIGN

Comply with Air Force Corporate Standards for Site Development:
<http://afcs.wbdg.org/site-development/index.html>

Comply with AF Corporate Standards for Site Design / NEPA:
<http://afcs.wbdg.org/site-development/site-design-nepa/index.html>

C01.1. Site Design Considerations

Applicable N/A Large graphics do not apply

Applicable N/A Small graphics do not apply

1. Nellis and Creech AFBs lie in the northeastern portion of the Mojave Desert. With the Sierra Nevada Range approximately 90 miles to the west and the Wasatch Range 135 miles to the east, the bases lie within the Colorado River drainage area. Separated from the moderating influence of the Pacific Ocean by hundreds of miles and by the lofty Sierra Nevada, the bases are dominated by a continental climate with pronounced winter and summer seasons and low rainfall. The bases are separated by a distance of 43 miles.
2. The climate at Nellis and Creech AFBs is typical of the desert southwest: sunny and arid with an average humidity of 18 to 39 percent and precipitation of approximately 4 inches annually. Most rainfall occurs during January-February and July-August and rainfall can be heavy at times, causing flash flooding. Summers are very hot, with an average high of 104°F in July. Winters are mild with an average high of 57°F and an average low of 37°F in January. Windy conditions are typical throughout the year.
3. Collect documentation to validate approvals and completion of the NEPA process.
4. Ensure site design compliance with the Installation Development Plan (IDP) and its component plans and Installation Facilities Standards (IFS).
5. Promote integrated design with on-site solutions such as engineered small-scale hydrologic controls versus base-wide infrastructure; consider open space, natural features, swales, berms, building roofs, streets, and paved surfaces.
6. Limit the impact of development on land and water resources. All site elements and infrastructure shall reinforce an image of sustainability, with reduced energy demand, renewable-energy usage, and water conservation.
7. Consider energy conservation during site design for the following categories: building and site lighting, auxiliary systems and equipment (refrigerators, elevators, etc.), building envelope, electric power and distribution, HVAC systems and equipment, and energy management (metering, EMCS).
8. Coordinate on-site renewable-energy systems and components to minimize area requirements and maximize efficiencies. Appropriately buffer and screen these and other mechanical systems and equipment.
9. New building projects should preserve open space and protect natural habitat.
10. Conform to existing topography to the greatest extent possible and use slopes to increase site and building efficiencies. Design sites to minimize irrigation and impacts to stormwater runoff.
11. Study new project sites to identify the character of adjacent buildings, streets, landscaping, and site design elements. Reinforce the existing character in new site design.
12. Consider relationships to adjacent facilities and district / centralized heating and cooling infrastructure and cost effectively connect building systems to harvest heat, grey water or other beneficial byproducts.

13. Purposefully integrate service access, receiving and storage areas to eliminate the need for visual screening.
14. Appropriately connect to the base network of streets, sidewalks and trails using drive aisles, parking areas, walkways, paths, and bicycle routes addressing both vehicles and pedestrians.
15. Consider heat island mitigation in paving and roof designs when implementing an integrated approach to stormwater management.
16. Consider the location of "Designated Tobacco Areas."

C01.2. Building Orientation

- Applicable N/A Select number of graphics / images (large: 800 px x 440 px) to insert 1
- Applicable N/A Select number of graphics / images (small: 250 px x 188 px) to insert 6

Image Tool 800 x 440

Image Tool 250 x 188

DRIVING FACTORS

- Optimal solar orientation of the building.
- Maximize the daylight & desirable views.
- Meet the required AT/FP standoff distance
- Create a unified campus
- Main entrance from Pepperrell street.
- Saving existing vegetation and trees
- Separation between staff/public/materials entrance
- Outdoor healing environment
- Addressing the orientation of the future ACC
- Visibility of the new facility from main roads
- Required parking spaces for public and staff
- Implementation of landscape zones A, B, C & D

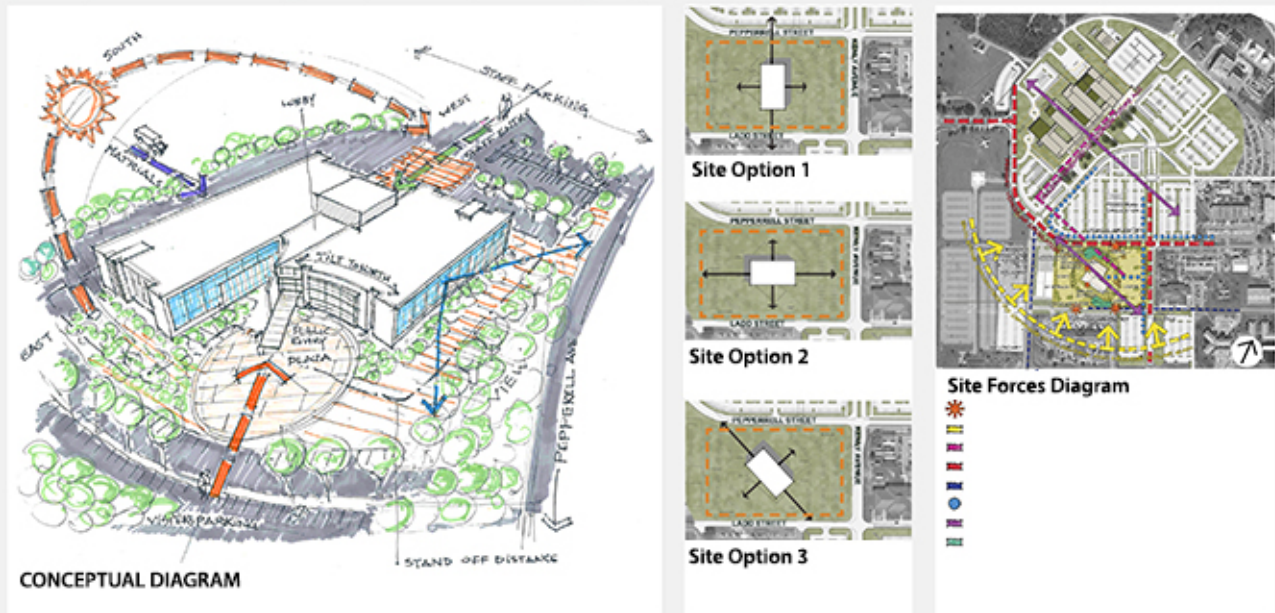

Conceptual Site Analysis and Site Design Diagram

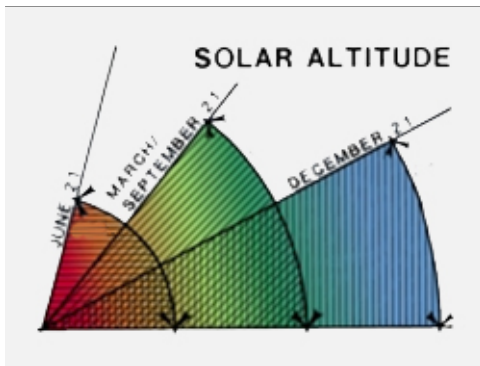

Local Solar Data

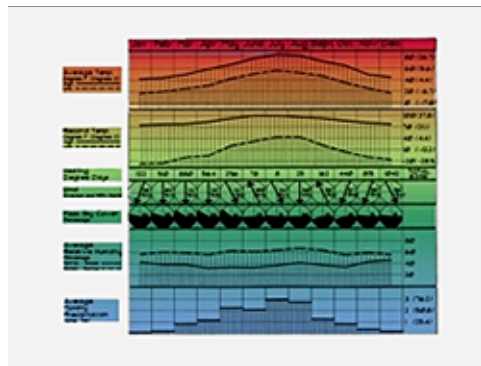

Local Climate Data

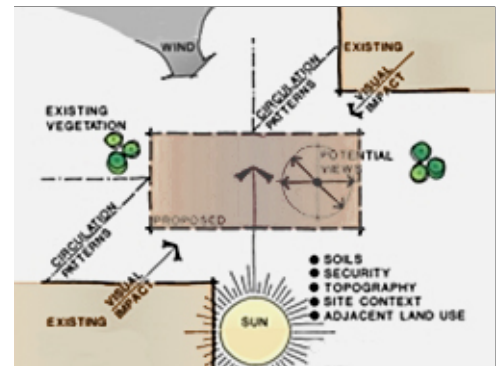

Site Data

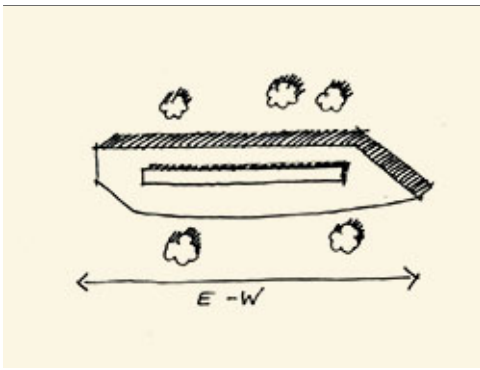

East-West Axis

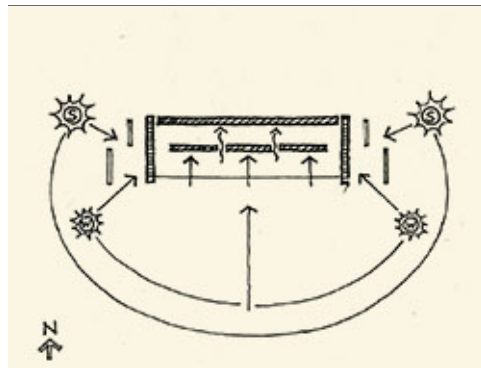

Optimum Solar Control

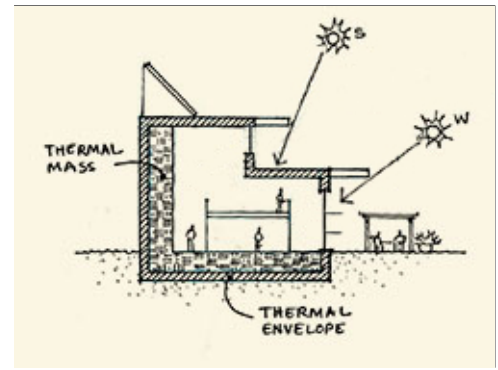

Maximized Shading

1. Strongly consider optimum requirements for building orientation, which is with the long axis parallel to the east/west direction for rectilinear buildings.
2. Meet Installation Facilities Standards (IFS) requirements for the locations of the building's passive and renewable-energy systems --including geothermal and solar systems --and exterior shading systems.
3. Strongly consider locating the building(s) and permitted ancillary structures to promote solar shading of main entrance and windows, natural ventilation, wind buffering and other beneficial passive systems. Consider natural ventilation during the design of HVAC systems.
4. Consider relationships to adjacent sites and their facilities and infrastructure, and cost effectively integrate building systems to harvest heat, grey water or other beneficial byproducts.
5. Consider the "public side" of the building, its views and the location of the main entrance.

C02. UTILITIES

Comply with AF Corporate Standards for Site Development:

<http://afcs.wbdg.org/site-development/index.html>

Comply with AF Corporate Standards for Utilities:

<http://afcs.wbdg.org/site-development/utilities/index.html>

C02.1. Utility Components

Applicable N/A Large graphics do not apply

Applicable N/A Select number of graphics / images (small: 250 px x 188 px) to insert 3

Image Tool 250 x 188



Mechanical Yard Enclosure and Access Drive



Mechanical Yard Enclosure and Access Drive



Mechanical Yard Enclosure

1. Provide all on-site utility service lines below grade for Facility Group 1; when mounting elements (such as utility cabinets, communications equipment and water valves) above grade is unavoidable, paint these Sierra Tan color or provide visual screening following Installation Facilities Standards (IFS).
2. Provide installation of utility infrastructure to support near term and future electric vehicle charging stations after a thorough analysis determining viability.
3. Define all service entry points into the building and route distribution below grade into an interior space within the facility; exposed conduits, pipes, cables and boxes on exterior walls are not permitted for Facility Group 1.
4. Comply with Utility Meter Requirements listed in Section G Appendix. Meters shall be connected to the base's Advanced Meter Reading System (AMRS) and support Automated Revenue Management Services (ARMS).
5. Limit exterior mechanical distribution systems such as exterior steam, chilled water, and hot water distribution to Group 3 facilities; when required for Group 1 and 2 facilities integrate with the architecture and provide visual screens following IFS.
6. Direct roof drainage to underground collection when feasible or provide concrete splash blocks / concrete channels to intercept roof drainage at grade.

C03. PARKING AREAS

Comply with AF Corporate Standards for Site Development:

<http://afcs.wbdg.org/site-development/index.html>

Comply with AF Corporate Standards for Parking Areas:

<http://afcs.wbdg.org/site-development/parking-areas/index.html>

C03.1. Configurations and Design

Applicable N/A Large graphics do not apply

Applicable N/A Select number of graphics / images (small: 250 px x 188 px) to insert 3

Image Tool 250 x 188

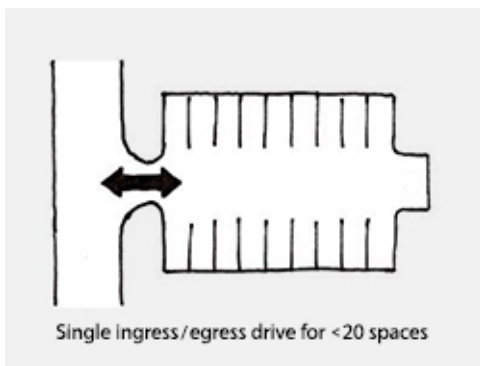

Small Lot Configuration

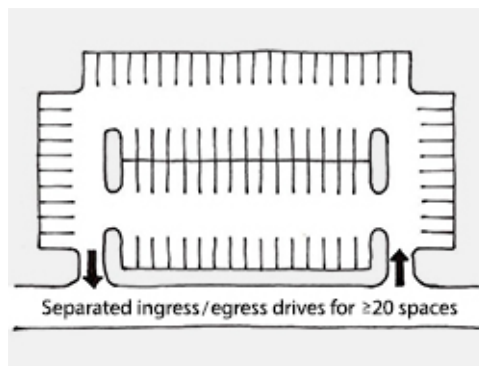

Large Lot Configuration

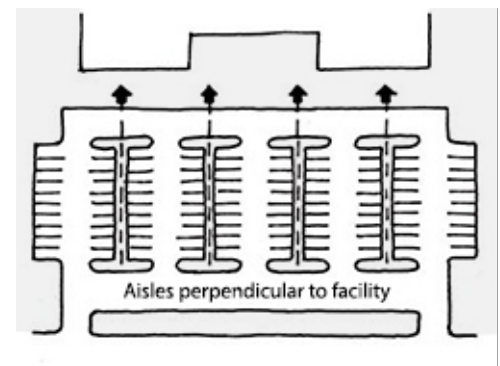

Facility Group 1 Configuration

1. Evaluate adjacent sites and cost-effectively consolidate parking areas to maximize efficient use; ensure that all areas meet accessibility guidelines.
2. Where possible, provide drop-offs at facility main entrance. Consider buffering parking areas from the facility main entrance with a transition space. Comply with IFS standards while meeting ATFP requirements.
3. Integrate at-grade and raised-profile curbing, permeable paved areas, and parking islands with the stormwater system and direct stormwater to swales and basins.
4. Define pedestrian access with approved hardscape and consider providing shading along the primary path from the parking area to the main entrance of the building.

5. Parking lot aisles shall be a minimum of 26 ft wide. Standard parking spaces shall be a minimum of 9 ft wide by 18 ft deep.
6. Coordinate suitable landscape or barriers integrated with walls and fences to ensure adequate force protection.
7. Accessible parking spaces shall be marked according to UFC 3-120-01 and its references in ABAAS and the MUTCD.
8. Consider locations and requirements of near term and future electric vehicle charging stations.
9. Designate preferred parking spaces for electric vehicles and carpools near the main entrance.
10. Consider cost-effectively integrating solar photovoltaic arrays into covered parking structures.
11. Limit reserved parking spaces and comply with AFI31-204.
12. On-street parking is discouraged except in multi-use areas. When used, provide approved on-street parking configurations following UFC 3-201-01.
13. Access and service drives should accommodate the largest vehicle serving the facility.

C03.1.1. Paving and Striping

Applicable N/A Large graphics do not apply

Applicable N/A Select number of graphics / images (small: 250 px x 188 px) to insert 3

Image Tool 250 x 188



GOV Access Drive



Flightline Equipment Parking



POV Parking

Facility Group 1 paving materials shall be as follows.

Primary: Asphaltic concrete

Secondary: Concrete

Accent: Permeable pavers

Facility Group 2 paving materials shall be as follows.

Primary: Asphaltic Concrete

Secondary: N/A

Accent: N/A

Facility Group 3 paving materials shall be as follows.

Primary: Concrete where operationally required

Secondary: Asphaltic Concrete

Accent: N/A

Facility Group 4 paving materials shall be as follows.

Primary: Asphaltic Concrete

Secondary: N/A

Accent: N/A

1. All new parking lots in Groups 1 and 2 shall be constructed of asphaltic concrete or concrete and meet requirements of UFC 3-250-01.
2. Porous paving may be considered on a case basis.
3. Cost-effectively provide light-colored concrete to reduce heat island effect; otherwise install asphaltic concrete paving. Native dirt or gravel lots are generally not allowed.
4. Use consistent striping, angles and stall sizes in all parking areas.
5. All parking shall be marked with white stripes of paint or applied vinyl coatings. Red or yellow markings shall only be used for safety purposes and must be kept to a minimum. All lines shall be four inches (4") wide.

C03.1.2. Curbing

Applicable N/A Large graphics do not apply

Applicable N/A Select number of graphics / images (small: 250 px x 188 px) to insert 3

Image Tool 250 x 188

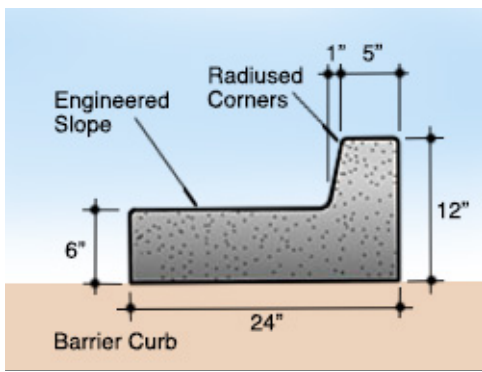

"Barrier" Curb

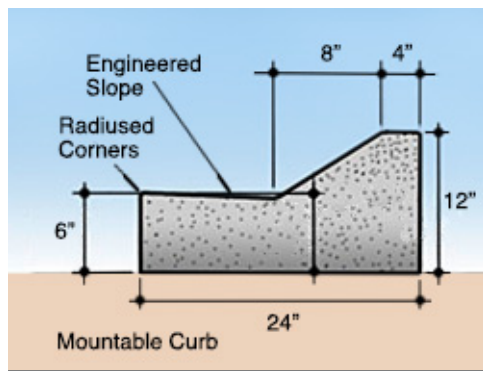

"Mountable" Curb

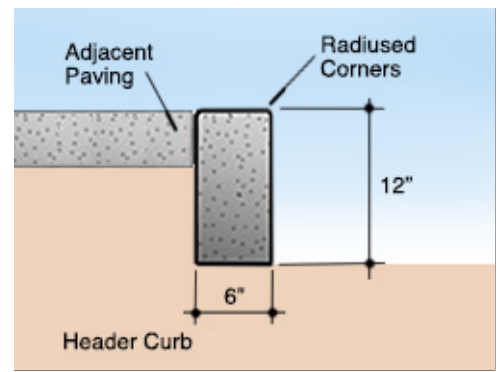

Header Curb

Facility Group 1 curbing / edging materials shall be as follows.

- Primary: Concrete
- Secondary: N/A
- Accent: N/A

Facility Group 3 curbing / edging materials shall be as follows.

- Primary: Concrete
- Secondary: N/A
- Accent: N/A

Facility Group 2 curbing / edging materials shall be as follows.

- Primary: Concrete
- Secondary: N/A
- Accent: N/A

Facility Group 4 curbing / edging materials shall be as follows.

- Primary: Concrete
- Secondary: N/A
- Accent: N/A

1. Define all parking lots with either raised profile or at-grade curbing to promote drainage and protect paving edges.
2. Install curbs and gutters to direct stormwater to drainage swales that connect to retention / detention basins. Provide 2 ft. wide curb cut at drainage swale location. Consider providing 2 ft. wide concrete gutter from curb cut to basin. Do not paint concrete curbing.

3. Wheel stops are not permitted except at sidewalks and locations where car bumpers could contact adjacent items such as poles or signs.
4. Building and mechanical room access drives used by GOVs should typically have retractable bollards at access point and have continuous at-grade (0 inch) concrete curbing along drive.

C03.1.3. Internal Islands and Medians

Applicable N/A Large graphics do not apply

Applicable N/A Small graphics do not apply

1. Install landscape islands and medians as visual breaks, to reduce heat island effects and to accommodate stormwater. Consider shade trees to shade parking spaces. Coordinate suitable landscape or barriers integrated with walls and fences to ensure adequate force protection.
2. When lighting is necessary, contain fixture bases within medians or internal landscape islands.

C03.2. Parking Structures

Applicable N/A Large graphics do not apply

Applicable N/A Small graphics do not apply

1. Parking structures should only be considered in land-constrained locations and when economically feasible. Parking structures should not be considered when adequate surface parking can be provided within a reasonable walking distance from facility.
2. Consider near term and future electric vehicle charging stations and renewable energy generation development during the analysis and design.
3. Consider opportunities for integrating parking structures into multi-use developments with pedestrian-oriented uses located on the ground floor and parking on upper levels; ensure AFTP guidelines are fully addressed.

C03.3. Connectivity

Applicable N/A Large graphics do not apply

Applicable N/A Small graphics do not apply

1. Refer to the Installation Development Plan (IDP) for locations of transit stops and pedestrian and cycling networks; provide appropriately sized sidewalks and bike paths to connect facilities and users to these networks.
2. Provide amenities such as rain and shade shelters, trees, and benches to encourage and facilitate use of public transportation.
3. Evaluate the IDP for the current and planned network of roads and optimally develop vehicular access to and from the site.

C04. STORMWATER MANAGEMENT

Comply with AF Corporate Standards for Site Development:

<http://afcs.wbdg.org/site-development/index.html>

Comply with AF Corporate Standards for Stormwater Management:

<http://afcs.wbdg.org/site-development/stormwater-management/index.html>

C04.1. Stormwater Requirements

Applicable N/A Large graphics do not apply

Applicable N/A Select number of graphics / images (small: 250 px x 188 px) to insert 6

Image Tool 250 x 188



Curb Cut and Swale



Curb Outlet and Swale



Curb Cut and Swale



Curb Cut and Swale



Retention Basin



Curb Outlet and Swale

1. Design all stormwater systems including retention basins, detention basins, channels, swales, etc. as on-site amenities that are consistent with natural systems and drainage patterns. Systems can provide aesthetic appeal when combined with landscape plan.
2. Comply with Clark County Regional Flood Control District requirements (www.ccrfcd.org). Coordinate system with base Stormwater Management Plan.
3. Incorporate drainage swales into the design of all roadway, parking and facility roof systems to enhance water quality and support the overall stormwater system.
4. Stormwater systems shall be designed to limit the accumulation of sediment and debris in the rock mulch ground cover as having sediment results in an abundance of weeds in the rock mulch.
5. Permeable paving may be used in areas that are not subjected to severe freeze-thaw cycles.
6. When underground drainage systems are required, establish a maintenance program to include removal of sediments and debris; inspect joints seasonally for alignment to prevent leakage and the development of voids and surface failures.
7. Cost-effectively integrate stormwater systems with ATRP measures.

C05. SIDEWALKS, BIKEWAYS AND TRAILS

Comply with AF Corporate Standards for Site Development:
<http://afcs.wbdg.org/site-development/index.html>

Comply with AF Corporate Standards for Sidewalks, Bikeways and Trails:
<http://afcs.wbdg.org/site-development/sidewalks-bikeways-trails/index.html>

C05.1. Circulation and Paving

Applicable N/A Large graphics do not apply

Applicable N/A Select number of graphics / images (small: 250 px x 188 px) to insert 6

Image Tool 250 x 188



Alignment with Main Entrance



Bollards for Controlled Access



Entrance Plaza



Concrete Paving at Facility



Concrete Paving at Plaza



Concrete Paving at Pavilion

Facility Group 1 sidewalks, plazas, and courtyards paving materials shall be as follows.

Primary: Pervious Pavers or Concrete Paving

Secondary: Concrete Paving and Edging

Accent: Colored Concrete

Facility Group 2 sidewalks, plazas, and courtyards paving materials shall be as follows.

Primary: Pervious Pavers or Concrete Paving

Secondary: Concrete Paving and Edging

Accent: Colored Concrete

Facility Group 3 sidewalks, plazas, and courtyards paving materials shall be as follows.

Primary: Concrete Paving

Secondary: N/A

Accent: N/A

Facility Group 4 sidewalks, plazas, and courtyards paving materials shall be as follows.

Primary: Concrete Paving

Secondary: N/A

Accent: N/A

1. Maintain efficient geometry and accessibility to connect building entrances to adjacent parking areas and activity areas and to the base transportation system following ATFP. Efficiently use materials to optimize life-cycle costs and to minimize maintenance.
2. Generally conform horizontal layouts of sidewalks to the geometric configuration of adjacent buildings, streets, parking lots, and other adjacent related site amenities. Occasional meanders and/or jogs may be included to capture views, to coordinate with landscaping or accommodate site constraints.
3. Walks in parking areas shall provide a direct path using "safe islands" and "peninsulas" to encourage safety. Walks parallel to streets shall follow streetscape guidelines. Clearly mark pedestrian crossings at vehicular routes.
4. Mitigate heat island by providing high-albedo, shaded sidewalks. Consider using pervious pavers for sidewalks, plazas and courtyards in Facility Groups 1 and 2; use concrete in Groups 3 and 4. Design shall incorporate appropriate expansion and construction joints.
5. Use experienced contractors to install pervious pavements.
6. Consider an integrated approach that could include stormwater management (permeable surfaces) and complement the design of the storm drainage system when appropriate.
7. Pedestrian paths should be at least 5' in width to allow for comfortable side-by-side walking.
8. Sidewalks leading to a building main entrance and at the interior of parking lots shall be a minimum width of 6 ft. Walks greater than 10 ft. wide may be used at high-density pedestrian areas where volumes of traffic justify added material.
9. All sidewalks shall have positive drainage to prevent ponding of water. Walks with a slope greater than 4.2% shall be designed as ramps following accessibility guidelines. All walks shall have a minimum cross slope of 2.1%.
10. Pavers shall be natural earth tone colors and pavers used on walks shall be a minimum of 4" x 8".
11. Connect to the bicycle circulation system and provide bicycle parking with a suitable means for securing bicycles following IFS. Consider changing/shower facilities for use by cyclists.
12. Refer to the Installation Development Plan for future trails, bicycle paths, and sidewalks.

C05.1.1. Ramps and Stairs

Applicable N/A Large graphics do not apply

Applicable N/A Small graphics do not apply

1. Use ramps instead of stairs for sidewalks, bikeways and trails and at all buildings where possible. Where steps are unavoidable, follow UFC 1-200-01 and its references to the International Building Code.

C05.1.2. Lighting

Applicable N/A Large graphics do not apply

Applicable N/A Small graphics do not apply

1. Provide lighting for all stairs and landings where traffic warrants.
2. Refer to the Lighting section for path lighting along sidewalks, bikeways and trails.

C06. LANDSCAPE

Comply with AF Corporate Standards for Site Development:

<http://afcs.wbdg.org/site-development/index.html>

Comply with AF Corporate Standards for Landscape:

<http://afcs.wbdg.org/site-development/landscape/index.html>

C06.1. Climate-based Materials

Applicable N/A Large graphics do not apply

Applicable N/A Select number of graphics / images (small: 250 px x 188 px) to insert 3

Image Tool 250 x 188



Limited Plantings with Rock Mulch



Xeric Plant Materials



Desert Trees and Shrubs

1. Use Mojave Desert appropriate, drought tolerant, and low water use plant species. Use natural non-decomposing rock mulch and boulders per IFS for ground cover.
2. Follow details and specifications of the American Standard for Nursery Stock, current edition. Also follow recommendations provided by Southern Nevada Water Authority Water Smart Landscape Program.

C06.1.1. Landscape Design Concept

Applicable N/A Large graphics do not apply

Applicable N/A Select number of graphics / images (small: 250 px x 188 px) to insert 3

Image Tool 250 x 188



Limited Turf Area



Desert Palette of Materials



Allee of Trees

1. Follow UFC 3-201-02 Landscape Architecture. All Facility Groups and developed sites shall have rock mulch installed throughout entire site. Use of unimproved exposed native soil around facilities (with no rock mulch ground cover) is prohibited. Concentrate landscape plantings in Facility Groups 1, 2 and 3 and along major thoroughfares and integrate these landscaped areas into the base's stormwater management plan. Refer to the Streetscape Envelope Standards in this IFS.
2. Facility Group 3 sites may have only rock mulch ground cover and boulders, and no trees or shrubs.
3. Over-planting should be avoided for all facility groups and it's more desirable to have trees for shade and visual interest than to have an abundance of shrubs. Multi-sized accent boulders may be provided in place of shrubs on a case basis. All drainage swales and retention / detention basins shall have river rock mulch ground cover.
4. Provide open spaces as transitions between developed and native desert areas that promote quality of life, provide visual relief and allow walkable connections between areas.
5. Use formal landscape planting arrangements only where appropriate. Consider using landscape plantings and walls as windbreaks.
6. Integrate security requirements into the landscape design. Coordinate heights, density, and location of trees and shrubs with ATFP requirements and restrictions stated in UFC 4-010-01.
7. Berms may be used as an integral part of the overall landscape strategy for screening, security and/or visual interest.

C06.1.2. Xeriscape Design Principles

Applicable N/A Large graphics do not apply

Applicable N/A Select number of graphics / images (small: 250 px x 188 px) to insert 3

Image Tool 250 x 188



Red Granite Rock Mulch



Red Granite Rock Mulch and River Rock



Red Granite Rock Mulch and River Rock

1. Apply xeriscape principles following UFC 3-201-02, Appendix B, and Air Force Corporate Facilities Standards.
2. Ground cover shall be rock mulch and boulders as follows:

Rock Mulch:

- Flat areas: ¾ inch granite: Rebel red color, installed 3 inches deep min.
- Sloped areas: 1 ½ inch granite: Rebel red color, installed 3 inches deep min.
- Accent areas, retention basins, and drainage swales: 3 inch to 12 inch river rock: Red, tan, and gray color, installed 4 inches deep min. Rock shall be naturally smooth, stream bed river run stone.

Boulders:

- Decorative rock boulders shall be red, tan, and/or brown color and be installed in a natural looking manner with bottom 1/3 buried. Sandstone shall not be used.
- Variety of sizes shall be installed. "Small" size boulders shall be 2 foot diameter, "Medium" size 3 foot diameter, and "Large" size 4 foot diameter.

C06.1.3. Minimizing Water Requirements

Applicable N/A Large graphics do not apply

Applicable N/A Select number of graphics / images (small: 250 px x 188 px) to insert 3

Image Tool 250 x 188



Boulders, Berms and Rock Mulch



Joshua Tree and Rock Mulch



Artificial Turf Field

1. Reasonably reduce demand on potable water while seeking opportunities to increase alternative water sources for irrigation. Consider using boulders, berms, swales, etc, in place of shrubs to provide visual interest in the landscape. Use low maintenance artificial turf in place of irrigated natural turf.

C06.1.4. Plant Material Selection

Applicable N/A Large graphics do not apply

Applicable N/A Select number of graphics / images (small: 250 px x 188 px) to insert 6

Image Tool 250 x 188



Drought Tolerant Species



Trees for Shading



Trees as Focal Point



Trees Used for Visual Interest



Trees Used for Shading



Specimen Planting

1. Use Mojave Desert appropriate, drought tolerant, low water use, and low maintenance plant species. Landscape plants should provide shade, cooling, and visual interest and also prevent erosion and improve air quality.
2. Base Landscape Plant List is available from the Base Civil Engineer (BCE) office. Plant selection is subject to BCE approval. Selection of plants shall be based on overall landscape design, project location, facility type, and microclimates such as protected areas, shaded areas, high heat areas, high wind areas, etc.
3. New tree planting container size shall be a minimum of 2 ft x 2 ft box. New shrub planting container size shall be a minimum of 5 gallons.
4. All plant material shall have a 1-year warranty and a 1-year maintenance contract from landscape contractor.
5. Trees should be the focus of landscape plantings and, where possible, should be a mix of deciduous and evergreen species for variety.
6. Natural and artificial turf areas should be limited to recreation and park areas. Artificial turf is preferred due to lower maintenance cost and no water use.

7. Analyze soils and provide organic amendments as needed to improve plant growth and conserve water.

C06.1.5. Water Budgeting (Hydrozones)

Applicable N/A Large graphics do not apply

Applicable N/A Small graphics do not apply

1. Comply with DoD and Air Force policy on potable-water irrigation systems and follow “Water for Landscaping” in UFC 1-200-02. Nellis and Creech AFB receive less than 4 inches of annual precipitation. Majority of plants require irrigation after plant establishment period due to the very limited rainfall that occurs sporadically and the extreme heat during summer months.
2. Provide permanent underground, fully automatic irrigation system that supports all landscape plants. System shall be designed and circuited for hydro zones and water conservation. Controllers shall be wall mounted in mechanical room or in mechanical yard, be lockable, and be easily accessible by base maintenance personnel. Backflow Prevention Unit (BPU) unit shall be insulated and provided with a freeze blanket cover and be located in a non-conspicuous location.
3. When life-cycle cost effective and permitted by local laws, new buildings should consider alternative water sources following UFC 1-200-02.
4. Provide irrigation design following UFC 3-201-02. Install drip irrigation products and components following UFGS Section 32 84 24 Irrigation Sprinkler Systems. Match the color of valve box lids to the adjacent ground treatment (i.e. green at turf areas, tan/brown at rock mulch areas).
5. When life-cycle cost-effective, equip irrigation systems to sense soil moisture, rainfall and wind to minimize unnecessary watering; incorporate drip irrigation systems as the primary source.

C06.1.6. Base Entrance Landscaping

Applicable N/A Large graphics do not apply

Applicable N/A Small graphics do not apply

1. At the main gate, reinforce a sense of arrival through a well-designed concentration of landscape elements consistent in visual quality with Facility Group 1.
2. Ensure landscaping has seasonal features with spring and fall color and a combination of evergreen and deciduous trees and shrubs for winter interest.
3. Integrate base signs and street and pedestrian lighting whenever feasible.

C06.1.7. Streetscape Landscaping

Applicable N/A Large graphics do not apply

Applicable N/A Small graphics do not apply

1. Provide landscape designs with plant materials appropriately representing the level of quality of the adjacent Facility Group number. Refer to the Installation Elements section.
2. Select a variety of Mojave Desert appropriate streetscape plantings, boulders, rock mulch, and swales / berms to create visual interest.

C06.1.8. Pedestrian Circulation Landscaping

Applicable N/A Large graphics do not apply

Applicable N/A Small graphics do not apply

1. Define walkways with landscaping where appropriate.
2. Where appropriate, provide rest areas along the pedestrian circulation network with human-scaled deciduous shade trees. Supplement tree plantings with finely textured shrubs or multi-sized accent boulders.
3. Provide wind breaks where required.

C06.1.9. Parking Lot Landscaping

Applicable N/A Large graphics do not apply

Applicable N/A Small graphics do not apply

1. Integrate appropriate landscaping elements into parking areas to visually soften the appearance. Provide trees in parking lot islands for shade and visual interest. Avoid trees that drop sap, fruit, or seeds, and only use long-lived species.
2. Stormwater from parking lots may be directed to adjacent basins which will absorb the water. Appropriate landscape plants may be installed in the basins. Swales and basins shall be designed to limit the accumulation of sediment and debris. Sediment results in an abundance of unwanted weeds and overgrowth in the rock mulch which is unsightly and a maintenance issue.

C06.1.10. Screen/Accent Landscaping

Applicable N/A Large graphics do not apply

Applicable N/A Small graphics do not apply

- 1 Where appropriate, provide accent landscaping at monuments and static displays. Consider providing landscaping adjacent to freestanding monument signs. Provide landscape screening of utility elements as appropriate.

C06.1.11. Other

Applicable N/A Large graphics do not apply

Applicable N/A Small graphics do not apply

C07. SITE FURNISHINGS

Comply with AF Corporate Standards for Site Development:

<http://afcs.wbdg.org/site-development/index.html>

Comply with AF Corporate Standards for Site Furnishings:

<http://afcs.wbdg.org/site-development/site-furnishings/index.html>

C07.1. Furnishings and Elements

Applicable N/A Large graphics do not apply

Applicable N/A Small graphics do not apply

1. Provide a coordinated consistent inventory of site furnishings to positively contribute to the visual environment, image, and identity of the base; ensure durability, low maintenance, reduced visual clutter, and compatibility with the adjacent architecture.
2. Remove poorly located or redundant litter / ash receptacles, bicycle racks, vending machines, walls and fences to reduce visual clutter and to lessen the requirements for maintenance.
3. Install needed outdoor seating (benches and low walls) in public gathering spaces near main and secondary building entrances. Low walls shall match facility architecture. Install concrete under benches and do not install benches on/ within walkways. Install adjacent to walkways.
4. Benches and picnic tables in all facility groups shall be precast concrete. Metal benches and metal picnic tables may be allowed on a case basis per BCE office approval. Typically, metal benches and tables are only allowed if installed under shade canopies.
5. Integrate functional bicycle racks with the design of the building's main entrance grounds in Facility Groups 1 and 2 while meeting AFTP requirements. Bicycle racks shall be stainless steel.
6. Limit the use of bollards, but when necessary for force protection use precast tan colored concrete bollards at Groups 1, 2, and 4. Use concrete filled steel bollards at Group 3 and where appropriate. Use retractable bollards to block traffic at roads and service driveways. Lighted bollards may be used along walkways as appropriate. Steel bollards shall be painted Sierra Tan.
7. Locate architecturally coordinated containers for recycling, litter, ash, vending, etc., to minimize visual clutter and not visible from the building's main entrance. Minimize the use of freestanding planters.
8. Generally limit picnic tables, barbeque grills and drinking fountains to lodging, dormitories, parks and recreation areas following IFS.
9. The Installation Flagpole location shall comply with the guidance for the display of flags in AFI 34-1201. Each Air Force installation is authorized to fly one United States Flag, normally in front of the installation headquarters. USAF Thunderbirds and USAF Schools may have their own US flagpoles. Waivers for non-authorized locations must be submitted in accordance with AFI 33-360 and approved waivers (AF Form 679) must be maintained by the installation protocol office.
10. Refer to the Overview Section "Facility Hierarchy" topic of this AFCFS for guidelines regarding ancillary structures such as pavilions and shade shelters. Shade structures may have angled louvers, concrete tile or SSMR as appropriate for the use and location. Structures with fabric or PTFE membrane (tensile fabric) shall be approved by BCE office on a case basis. Structure's columns shall be CMU or steel with CMU enclosure.
11. Bus shelters shall be provided only where there is a documented need and when approved on a case basis. Generally emulate design of existing bus shelters with factory finish low maintenance materials.
12. Monuments and static displays shall be limited. New elements are generally discouraged unless these are fully vetted through the base's approval process and designed following IFS.
13. When visual screening is necessary, provide CMU walls with integral color, texture and pattern that matches adjacent facility. Screen all mechanical yards. Walls shall be high enough to screen all equipment and design shall meet AFTP requirements. Provide lockable doors / metal gates to mechanical yards and provide concrete pavement in entire yard.
14. For fencing, apply the standards for "Products, Materials and Color" in the following section. Limit those with the highest visual quality to Facility Group 1 where there is sustained maintenance. Define all levels of security and visual quality.

- 15. Chain-link fencing at Group 1, 2 or 4 facilities may only be used on a case basis. Limit the use of barbed-wire outriggers on chain-link fencing at industrial sites, unless required for additional security or protection of assets.
- 16. Wood fencing shall not be used except in Facility Group 4 on a case basis.
- 17. Provide trash dumpster enclosures at all concrete dumpster pads. Enclosure wall shall be CMU with integral color, texture, and pattern that matches adjacent facilities. Gates shall be factory finish metal, Sierra Tan color. Gates shall be stable/locked when in open and in closed position and meet all building wind load requirements.
- 18. All materials on screen walls shall be factory finish and not require painting or maintenance.
- 19. Provide kiosks only where there is a documented need for visual communication of posted messages. When used, match adjacent facilities in materials and detailing and consolidate kiosks with other site furnishings within 30 feet of major pedestrian paths. Limit kiosks to facility Groups 1 and 2 and parks.
- 20. Manufacturers listed below are only provided to establish a baseline of equivalency among all applicable manufacturers.

C07.2. Site Furnishings Products, Materials and Color

Note: Apply the below base-wide standards for Site Furnishings (products, materials and color). Then refer to the Appendix and apply any additional requirements specifically related to the Facility District in which the project is located.

C07.2.1. Barbeque Grills

Applicable N/A Number of base standards 1

Image Tool 250 x 188



Type: **Charcoal**

Applies to: Group 1 Group 2 Group 3 Group 4 Other

Mfr: Most Dependable Fountains, Inc.

Color: Natural stainless steel

Finish: Mill

Model #: SS BBQ Grill

Other: Concrete foundation

UFGS: N/A

C07.2.2. Benches

Applicable N/A

Number of base standards 2

Image Tool 250 x 188

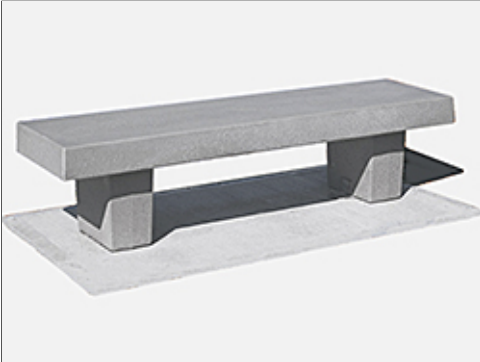

Type: **Precast Concrete**

Applies to: Group 1 Group 2 Group 3 Group 4 Other

Mfr: Belson

Color: Tan

Finish: Standard Finish (Smooth)

Model #: TF5029

Other: 6 foot length min.

UFGS: N/A

Type: **Metal**

Applies to: Group 1 Group 2 Group 3 Group 4 Other

Mfr: Patterson Williams

Color: Tan or Medium Brown

Finish: Powder Coat

Model #: Xander Series Bench with Back

Other: 6 foot length min.

UFGS: N/A



C07.2.3. Bike Racks

Applicable N/A

Number of base standards 1

Image Tool 250 x 188



Type: **Stainless Steel**

Applies to: Group 1 Group 2 Group 3 Group 4 Other

Mfr: N/A

Color: Stainless Steel

Finish: Factory

Model #: N/A

Other: N/A

UFGS: N/A

C07.2.4. Bike Lockers

Applicable N/A

C07.2.5. Bollards

Applicable N/A

Number of base standards 3

Image Tool 250 x 188



Type: **Lighted**

Applies to: Group 1 Group 2 Group 3 Group 4 Other

Mfr: AccuLite

Color: Dark bronze

Finish: Anodized aluminum

Model #: PL2 Series

Other: All aluminum LED Fixture

UFGS: N/A



Type: **Retractable, Stainless Steel**

Applies to: Group 1 Group 2 Group 3 Group 4 Other

Mfr: Calpipe Industries and Reliance Foundry

Color: Stainless Steel

Finish: A316 Stainless Steel

Model #: Calpipe Product STP 4000-TH and Reliance Foundry Model R-8471

Other: Used to block streets and service driveways for ATFP.
Install retractable bollards a minimum of 4 ft. on center.
4 in. diameter with lifting handle and key locking mechanism.

UFGS: N/A

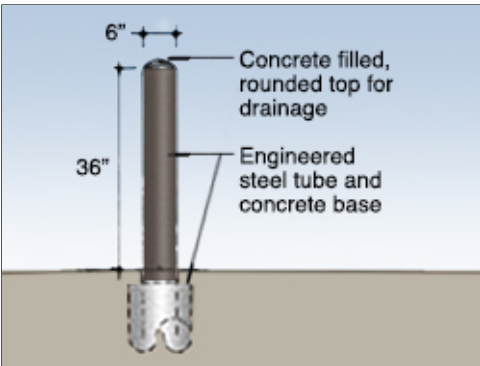

Type: **Fixed, Steel**

Applies to: Group 1 Group 2 Group 3 Group 4 Other

Mfr: N/A

Color: Sierra Tan

Finish: Field painted

Model #: 6" Steel pipe, concrete filled

Other: Height varies per use and location

UFGS: N/A

C07.2.6. Bus Shelters

Applicable N/A

C07.2.7. Drinking Fountains

Applicable N/A

C07.2.8. Dumpster Enclosures / Gates

Applicable N/A

Number of base standards 1

Image Tool 250 x 188



Type: **CMU and Steel**

Applies to: Group 1 Group 2 Group 3 Group 4 Other

Mfr: Custom

Color: Reference CMU Exterior Walls

Finish: Reference CMU Exterior Walls

Model #: N/A

Other: Reference Section C07.1.17

UFGS: Section 04 20 00 Unit Masonry; Section 05 50 13 Misc. Metal

C07.2.9. Fencing

Applicable N/A

Number of base standards 3

Image Tool 250 x 188

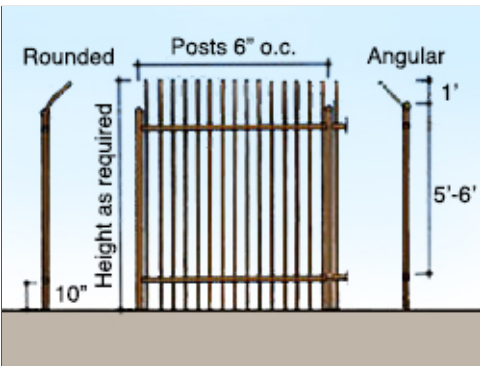

Type: **Style A Barrier: High security, high visibility**

Applies to: Group 1 Group 2 Group 3 Group 4 Other

Mfr: Custom

Color: Dark bronze/brown

Finish: Powder coat

Model #: Steel posts, rails and pickets (vertical, bent outward at top)

Other: CMU piers may be used

UFGS: Section 05 50 13 Miscellaneous Metal Fabrications

Type: **Style B Barrier: High security, medium visibility**

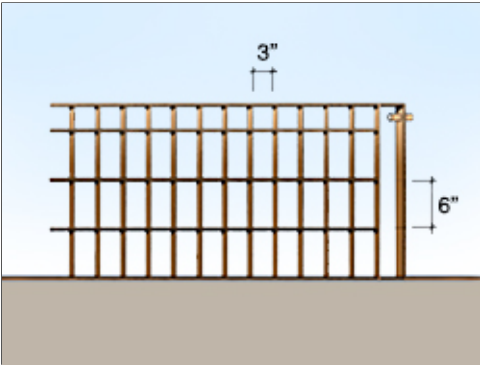

Applies to: Group 1 Group 2 Group 3 Group 4 Other

Mfr: Custom

Color: Dark bronze/brown

Finish: Powder coat

Model #: Steel grid: flat bar stock verticals, round rod horizontals

Other: Steel posts, horizontal bars, braces, and accessories, in heights, lengths, and gauges as required; Close all ends of tubing

UFGS: Section 05 50 13 Miscellaneous Metal Fabrications

Type: **Style C Barrier: High security, low visibility**

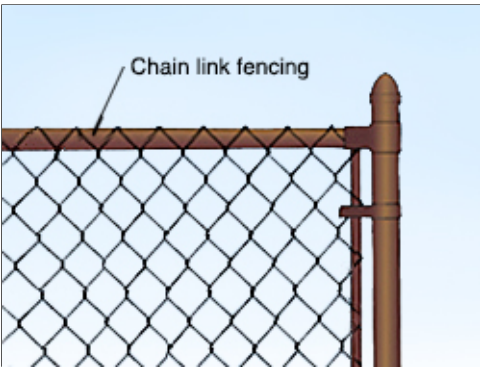

Applies to: Group 1 Group 2 Group 3 Group 4 Other

Mfr: Custom

Color: Dark bronze/brown

Finish: Powder coated galvanized steel

Model #: Chain link, steel posts and rails, gates and accessories

Other: Posts and rails in heights, lengths and gauges as required

UFGS: Section 32 31 13 Chain Link Fences and Gates

C07.2.10. Flagpoles

Applicable N/A

C07.2.11. Lighting – Landscape / Accent

Please refer to the Lighting section.

C07.2.12. Litter and Ash Receptacles

Applicable N/A

Number of base standards 2

Image Tool 250 x 188

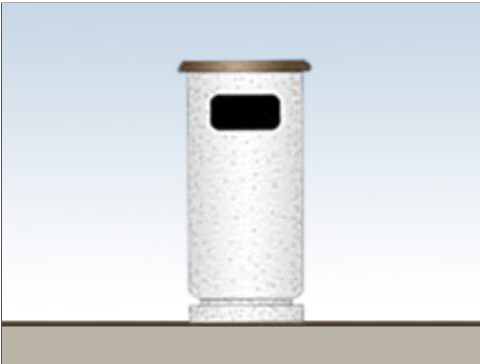

Type: **Precast Concrete**

Applies to: Group 1 Group 2 Group 3 Group 4 Other

Mfr: Materials, Inc.

Color: Tan

Finish: Smooth

Model #: TR-3225 Sante Fe (Round)

Other: Rigid plastic internal liner

UFGS: N/A

Type: **Metal**

Applies to: Group 1 Group 2 Group 3 Group 4 Other

Mfr: The Park Catalog

Color: Tan or Medium Brown

Finish: Powder Coat

Model #: 398-8002, Plaza Steel Strap Trash Receptacle - 36 Gallon

Other: Flat top lid

UFGS: N/A



C07.2.13. Picnic Tables

Applicable N/A

Number of base standards 2

Image Tool 250 x 188



Type: **Precast Concrete**

Applies to: Group 1 Group 2 Group 3 Group 4 Other

Mfr: Belson

Color: Tan

Finish: Ground and polished, or acid washed

Model #: TF312512, 4 seats

Other: N/A

UFGS: N/A

Type: **Metal**

Applies to: Group 1 Group 2 Group 3 Group 4 Other

Mfr: The Park Catalog

Color: Tan or Medium Brown

Finish: Powder Coat

Model #: 145-1636, 46 Square WEB Style Classic (4 Post)

Other: N/A

UFGS: N/A



C07.2.14. Planters

Applicable N/A

C07.2.15. Play Equipment

Applicable N/A

Number of base standards 1

Image Tool 250 x 188



Type: **Steel**

Applies to: Group 1 Group 2 Group 3 Group 4 Other

Mfr: Little Tikes Commercial

Color: Varies

Finish: Powder Coated Steel

Model #: N-R-G Freestyle

Other: Coordinate with Base Civil Engineer office and Child Development Center office. Provide shade structure or canopy.

UFGS: N/A

C07.2.16. Screen Walls

Applicable N/A

Number of base standards 1

Image Tool 250 x 188



Type: **CMU**

Applies to: Group 1 Group 2 Group 3 Group 4 Other

Mfr: Custom

Color: Reference CMU Exterior Walls

Finish: Reference CMU Exterior Walls

Model #: N/A

Other: Reference Section C07.1.13

UFGS: Section 04 20 00 Unit Masonry

C07.2.17. Tree Grates

Applicable N/A

C07.2.18. Other

Applicable N/A

C08. EXTERIOR SIGNS

Comply with AF Corporate Standards for Site Development:

<http://afcfs.wbdg.org/site-development/index.html>

Comply with AF Corporate Standards for Exterior Signs:

<http://afcfs.wbdg.org/site-development/exterior-signs/index.html>

C08.1. Colors and Types

Applicable N/A Large graphics do not apply

Applicable N/A Select number of graphics / images (small: 250 px x 188 px) to insert 6

Image Tool 250 x 188



Sign at Main Entrance



Sign on CMU



Monument Sign



Sign on Metal Panel



Monument Sign with Uplighting



Sign Coordinated with Wall Pattern

1. Provide concise functional signs as a visually unifying element with consistent colors and types for all Installation and Gate Identification Signs; Building Identification Signs; Traffic Control Devices; Directional and Wayfinding Signs; and Informational and Motivational Signs.
2. All exterior signage shall be approved by Base Civil Engineer (BCE) office.
3. Provide signs with the lowest overall life-cycle costs considering initial cost, ongoing maintenance and lifespan while meeting quality standards.

4. Reduce the number of signs, reduce visual clutter and provide only essential signs required for identification, directions, instructions, and customer service following UFC 3-120-01. Remove non-conforming signs during renovation projects. Signage should help create a unified, cohesive and professional appearance throughout the base.
5. Use clear concise terms for content consistent with UFC 3-120-01. Lettering style for all exterior building signs shall be Helvetica. Helvetica Medium or Bold shall be used for primary information and Helvetica Regular shall be used for secondary information.
6. Building identification signs shall consist of wall mounted letters / numbers and shall be limited to the main facility functional name or unit identification. Abbreviations are preferred. If two main functions share a facility, both titles can be displayed. Individual letters/numbers shall be three-dimensional and be constructed of dark bronze colored anodized aluminum. Font shall be uppercase Helvetica medium style with letter height proportional to signage location and facility size. Letters on majority of facilities are 12 inches high. Letters shall be pin mounted directly to the exterior material of the facility and not be mounted to a separate metal panel. Provide an appropriate space between the letters and the wall material. Plastic and Styrofoam lettering should not be used.
7. Installation of wall mounted unit patches or emblems shall be limited to the unit headquarters facility and only one patch per unit is allowed. Patch should be located near the main building entrance and near the unit/building name signage, if provided. Vertical dimension of patch shall not be greater than 4 feet. Patch shall be professionally manufactured and be factory-painted on a silhouetted aluminum panel. Panel shall have an appropriate gauge thickness and be mounted approximately 1 inch from the wall surface to create a shadow. USAF Thunderbirds, USAF Weapons School, and Red Flag are exempt from limits on size and number of unit patches.
8. All facilities shall have a minimum of two building number signs. Signs shall be wall-mounted and be 8 inches high by 16 inches long and installed approximately 8 feet above ground, typically near building corner. Signs are one-piece brown color metal with Helvetica Medium font numbers in white.
9. All facilities shall have room identification signage at all exterior service doors. Signage shall be approximately 4 inches high by 8 inches long and state room name and number. Color shall be brown with white typeface and material shall be weatherproof and UV resistant.
10. Post-mounted, freestanding building identification signs with building name and street address / building number are prohibited.
11. Monument signs may be appropriate for certain high profile facilities and shall be approved by BCE on a case basis. Signs shall be appropriately sized, located, lighted, and coordinated with landscape design.
12. Traffic Control Devices, which regulate vehicular traffic on the installation, shall conform to the standards in the Manual of Uniform Traffic Control Devices (MUTCD) published by the Federal Highway Administration. Coordinate street signs with this IFS.
13. Provide Directional and Wayfinding Signs and address both pedestrian and vehicular traffic following UFC 3-120-01 for size, layout and content.
14. Reserved parking signs should be kept to a minimum. When approved, provide post-mounted sign faces in base standard materials and colors or provide curb mounted signs.
15. Parking lot identification signs may be used to identify areas or rows within large lots.
16. Follow the guidelines and requirements in ABAAS and the MUTCD for accessible parking signs.
17. Symbols or pictographs (graphic expressions of actual objects) may be used to indicate service, mandatory / prohibitory, sports, and recreation when rapid communication is necessary.
18. Refer to UFC 3-120-01 for prohibited signs, which include those with animated, blinking, chasing, flashing, or moving effects. If lighting is required for signs, appropriate LED light fixtures shall be installed at the appropriate location. Internally lighted signs are limited to special commercial applications and shall be approved by BCE office.

C08.1.1. Materials and Color Specifications

Applicable N/A Large graphics do not apply

Applicable N/A Small graphics do not apply

1. Fabricate sign panels from aluminum flat sheet for Typical Sign Face. Sign posts shall be Extruded aluminum with capped top ends for Typical Sign Post in a concrete base.
2. Fence mounted sign panels may be attached with exposed fasteners.
3. All signage shall follow Federal Highway Administration (FHWA) Manual on Uniform Traffic Control Devices (MUTCD) using standard colors. Refer to MUTCD color specifications, which provide cross-referenced Pantone Matching System (PMS) numbers:
 - a. Standard Blue
 - b. Standard Dark Bronze (also Federal Standard Color 30040)
 - c. Standard Red
 - d. Standard Black (non-reflective)
 - e. Standard White
 - f. Standard Brown

Materials and Color Specifications

Applicable N/A

C08.1.2. Installation and Gate Identification Signs

Applicable N/A

C08.1.3. Building Identification Signs

Applicable N/A Number of base standards 4

Image Tool 250 x 188



Type: **Wall Mounted Letters**

Applies to: Group 1 Group 2 Group 3 Group 4 Other

Mfr: TBD

Color: Dark Bronze

Finish: Anodized Aluminum

Model #: N/A

Other: Reference Section C08.1, Paragraph 6

UFGS: N/A



Type: **Wall Mounted Emblems**

Applies to: Group 1 Group 2 Group 3 Group 4 Other

Mfr: Custom

Color: Reference Section C08.1

Finish: Reference Section C08.1

Model #: N/A

Other: Reference Section C08.1, Paragraph 7

UFGS: N/A



Type: **Wall Mounted Building Numbers**

Applies to: Group 1 Group 2 Group 3 Group 4 Other

Mfr: Custom

Color: Reference Section C08.1

Finish: Reference Section C08.1

Model #: N/A

Other: Reference Section C08.1, Paragraph 8

UFGS: N/A

Type: **Sign Monuments**



Applies to: Group 1 Group 2 Group 3 Group 4 Other

Mfr: Custom

Color: Reference CMU Exterior Walls

Finish: Reference CMU Exterior Walls

Model #: N/A

Other: Reference Section C08.1, Paragraph 11

UFGS: N/A

C08.1.4. Traffic Control Devices (Street Signs)

Applicable N/A Number of base standards 1

Image Tool 250 x 188



Type: **Street Signs**

Applies to: Group 1 Group 2 Group 3 Group 4 Other

Mfr: Custom

Color: White reflective lettering on a Standard Brown background

Finish: Powder coat or vinyl sign face

Model #: Aluminum sign face, control arm or pole mounted

Other: Mount 7' above grade minimum, pictographs and logos are prohibited on street name signs per UFC.

UFGS: Section 05 50 13 Miscellaneous Metal Fabrications

C08.1.5. Directional and Wayfinding Signs

Applicable N/A Number of base standards 1

Image Tool 250 x 188



Type: **Vehicular**

Applies to: Group 1 Group 2 Group 3 Group 4 Other

Mfr: Custom

Color: Medium Brown face, white letters, Sierra Tan posts.

Finish: Powder coat or vinyl sign face

Model #: Aluminum flat sheet, extruded aluminum posts

Other: Mount to square posts. Provide sizes following UFC

UFGS: Section 05 50 13 Miscellaneous Metal Fabrications

C08.1.6. Informational Signs

Applicable N/A Large graphics do not apply

Applicable N/A Small graphics do not apply

1. Minimize informational signs such as static display signs, hours of operation, and project signs to reduce visual clutter.
2. Static display signs shall have standard medium brown face and white vinyl lettering.
3. Hours of operation signs shall have a level of quality equivalent to the Facility Group number.
4. Temporary signs are not permitted except for construction signs. Temporary commercial signs that advertise sales and promotions are prohibited. Construction signs may be allowed during project construction and shall be removed promptly after project completion. Sign should be parallel to the street with location approved by the Contracting Officer. Sign should include project name, project number, contracting agency, general contractor name, and contact phone number. If required, provide a separate Clark County dust permit sign and a Nevada SWPPP permit sign. Signs shall be free-standing, ground-mounted type, and not be attached to buildings or walls. Contractor shall not install any additional signs on temporary trailers and subcontractor signs are not allowed.

C08.1.7. Motivational Signage

Applicable N/A Large graphics do not apply

Applicable N/A Small graphics do not apply

1. Provide professionally produced motivational signs as important elements of campaigns to boost morale, improve safety, aid in recruiting, and accomplish other motivational objectives. Consolidate this signage to reduce visual clutter. Minimize the number of motivational signs to avoid a distracting and cluttered base appearance.
2. Motivational signs shall be limited to an electronic "marquee" type changeable sign near each gate. Temporary signs are not permitted. Motivational information may also be posted in a small, printed format on kiosks in specified, high pedestrian use areas. Refer to kiosks under Site Furnishings.

3. Follow UFC 3-120-01 for color and layout. Note that animated, blinking, chasing, flashing, or moving effects are prohibited by the UFC.

4. Unit motivational/morale signs on exterior of facilities or on sign monuments are prohibited.

C08.1.8. Parking Lot Signs

Applicable N/A

C08.1.9. Regulatory Signs

Applicable N/A

1. Regulatory signage, which restricts, warns and advises, shall be limited to those mandated under Highway/Traffic, Government Warning, and/or Parking Regulation. Follow UFC 3-120-01 and its industry references for color and layout.
2. Provide a comprehensive, systematic approach to regulatory signage to avoid clutter and confusion from "over signage."
3. Maintain base warning signs for safety and security at the base perimeter and at specific secure areas. Use these to notify visitors of restrictions governing conduct on the base, as well as other security procedures.

C08.1.10. Other

Applicable N/A

C09. LIGHTING

Comply with AF Corporate Standards for Site Development:

<http://afcfs.wbdg.org/site-development/index.html>

Comply with AF Corporate Standards for Lighting:

<http://afcfs.wbdg.org/site-development/lighting/index.html>

C09.1. Fixtures and Lamping

Applicable N/A Large graphics do not apply

Applicable N/A Select number of graphics / images (small: 250 px x 188 px) to insert 3

Image Tool 250 x 188



Lighting at Main Entrance



Security and Accent Lighting



Decorative and Accent Lighting

1. Provide, coordinate and efficiently install street, parking lot, sidewalk and facility lighting with appropriate luminaires, lamping, placement and spacing following UFC 3-530-01 and Installation Facilities Standards (IFS); ensure the level of quality is consistent with the adjacent facility group number. Pole-mounted, wall-mounted and bollard fixtures are permitted.
2. Comply with Nellis-Creech Lighting Requirements in Section G Appendix. All interior and exterior lamps shall be LED.
3. Integrate controls to automatically reduce lighting power during periods of non-activity; automatically turn off power when sufficient daylight is available.
4. Ensure continuity and consistency of lighting elements. Light fixtures and poles shall have a dark bronze finish unless a tan color is approved by BCE office on a case basis. In new construction generally match post types, fixture types, styles, heights, sizes, materials, colors, and lamp types of adjacent facilities and the facility district.
5. Economically provide renewable-energy power sources such as solar photovoltaic when feasible.
6. Use appropriately designed or shielded luminaires to direct light downward to minimize light pollution and intrusion onto adjacent sites.
7. Calculate illuminant levels for all lighting applications following UFC 3-530-01 and ensure compliance with pre-curfew maximum brightness level requirements.
8. Sufficiently address environmental factors to prevent corrosion and weathering of fixtures, plinths and other components.
9. Wall mounted fixtures should respond to the architectural character of the facility.
10. Efficient accent lighting of architectural and landscape features may be provided for Group 1, lodging and other appropriate applications. Accent lights in ground-mounted locations may be provided for static displays and signs when these do not conflict or cause hazards with base operations.
11. Provide round tapered, square non-tapered, or round non-tapered aluminum poles and aluminum fixtures with square, rectangular or circular housings in colors and shapes to match adjacent facilities and the facility district. Exceptions may be made on a case basis.

12. Install lighted bollards only at Group 1 and high-traffic Group 2 facilities. Reference Section C07.2.5 for information on lighted bollards.
13. Install natural warm gray color, smooth finished concrete bases for all poles. Top of concrete base should match adjacent grade except at poles in parking lots and adjacent to vehicles and moveable equipment. At those locations the top of concrete shall be a minimum of 2'-6" above grade.
14. When parking lot lighting is necessary, provide an illuminated path to the building's main entrance. Pole bases should be contained within an internal landscape median or island.
15. Consistently install lighting for sidewalks, bikeways and trails to match adjacent facilities.
16. Landscape accent lighting may be used in public gathering spaces and in Group 1 facilities. Coordinate the design, luminaire selection, and placement with the location of trees, shrubs, and site furnishings.

C09.2. Light Fixture Types

Note: Apply the below base-wide standards for Light Fixtures (products, materials and color). Then refer to the Appendix and apply any additional requirements specifically related to the Facility District in which the project is located.

C09.2.1. Street Lighting

Applicable N/A

C09.2.2. Parking Lot Lighting

Applicable N/A

C09.2.3. Lighted Bollards

Applicable N/A

C09.2.4. Sidewalk Lighting

Applicable N/A

C09.2.5. Walls / Stairs Lighting

Applicable N/A

C09.2.6. Other

Applicable N/A

D. FACILITIES EXTERIORS

Comply with Air Force Corporate Standards for Facilities Exteriors:

<http://afcs.wbdg.org/facilities-exteriors/index.html>

Applicable N/A Large graphics do not apply

Applicable N/A Select number of graphics / images (small: 250 px x 188 px) to insert 3

Image Tool 250 x 188



Integrated Shading



Limited Use of Windows



Coordinated Wall Materials

D01. SUPPORTING THE MISSION

Comply with AF Corporate Standards for Supporting the Mission:

<http://afcs.wbdg.org/facilities-exteriors/supporting-the-mission/index.html>

D02. SUSTAINABILITY

Comply with Air Force Corporate Standards for Sustainability:

<http://afcs.wbdg.org/facilities-exteriors/supporting-the-mission/index.html>

D03. ARCHITECTURAL FEATURES

Comply with AF Corporate Standards for Facilities Exteriors:

<http://afcfs.wbdg.org/facilities-exteriors/index.html>

Comply with AF Corporate Standards for Architectural Features:

<http://afcfs.wbdg.org/facilities-exteriors/architectural-features/index.html>

Insert 3 photos for each facility group.

Image Tool 250 x 188

Group 1



Group 2



Group 3



Group 4



D03.1. Orientation, Massing and Scale

1. Orient new buildings to maximize energy efficiency, passive solar and daylighting potential of the building; narrow buildings oriented along an east-west axis are preferred to minimize heat gain in the summer months and maximize heat gain in the winter months resulting in less overall energy usage.
2. Provide orthogonal geometry for principal building form; angular geometry may be used sparingly for Group 1 and used only for emphasis at specific areas such as building entrances and stairwells.
3. Maintain a human scale and reduce the visual scale of large buildings with sub-massing related to interior functional operations; create consistent form and scale in adjacent buildings with compatible profiles or silhouettes.
4. Building heights shall not be limited; however, building heights over 2 stories shall be considered on a case basis.
5. Combine functions where practical to avoid a proliferation of small, independent structures.
6. Use and coordinate shading devices with orientation and for function.

D03.2. Architectural Character

1. Develop architectural features, materials and detailing appropriate for the Facility Group designation. Refer to Building Entrances, Wall Systems and Roof Systems.
2. Respond to the Mojave Desert climate and regional influences with environmentally functional architectural features.
3. For new facilities design generally maintain consistency and visual unity in the character of the adjacent buildings through compatible architectural features: repeated use of similar forms such as roofs, and through recurring elements such as doors, windows, materials and colors.
4. Reinforce the base's campus environment and complement adjacent facility design.
5. All facilities shall express sustainability through their orientation, massing, shape, form, materials, and detailing. Provide louvers, fins and other shading devices to control heat gain and glare and to and improve energy efficiency.
6. Strive for economical construction without compromising a high-quality, professional appearance.

D03.3. Details and Color

1. Provide a palette of earth-tone colors related to the native landscape in concrete masonry units (CMU), powder coated metals, and stucco. Refer to wall systems for detailed material listings.
2. Relate the level of architectural detailing to the Facility Group number.
3. Use only integrally colored materials as the predominant exterior building material; do not use materials that require field painting and ongoing maintenance.
4. Provide consistent and compatible colors for every exterior building feature, including walls, roofs, doors, windows, gutters, downspouts, utility and mechanical elements, and other visible elements.
5. Noncorrosive metals with factory applied color finishes are required.
6. Combine details and color with orientation, massing, scale and architectural character to maintain base compatibility.
7. Manufacturers listed below are only provided to establish a baseline of equivalency among all applicable manufacturers.

D03.3.1. Climate-based Data and Life-Cycle Cost-Effective Passive and Natural Design Strategies:

- Climate dominated by mechanical cooling
- Climate dominated by mechanical heating
- Climate with similar mechanical cooling / heating needs
- Climate with minimal mechanical cooling / heating needs

- Climate with high humidity
- Climate with moderate humidity
- Climate with low humidity

- High Solar Insolation
- Moderate Solar Insolation
- Low Solar Insolation

- Soils with High Thermal Conductivity
- Soils with Average Thermal Conductivity
- Soils with Low Thermal Conductivity

Other: Consider effects of high wind and localized heavy rain/flash flooding.

Other: North or south facing exposures are preferred for main entrances.

Facility: Narrow buildings along E-W axis are preferred for buildings with windows.

Wall: Integral shading features and devices. interior masonry thermal mass walls (for cooling).

Doors: Recessed are preferred for shading and high wind.

Windows: Provide insulating glazing on all windows. Shade all east, west, and south facing windows and entrances.

Roof: High to medium albedo. Minimal to moderate slope.

Structure: Do not expose ferrous metals. Provide factory finished non-ferrous metals or concrete.

MEP: Ground-source following LCCA.

Other: Internal thermal mass walls may be used for cooling following LCCA.

Other: N/A

Note: Apply the below *base-wide standards* for Architectural Features (products, materials and color). Then refer to the Appendix and apply any additional requirements specifically related to the Facility District in which the project is located.

D03.3.2. Natural Ventilation System

Applicable N/A

Number of base standards 1

Image Tool 250 x 188



Type: **Style 1 Aluminum Windows**

Applies to: Group 1 Group 2 Group 3 Group 4 Other

Mfr: Kawneer (or equivalent)

Color: Dark Bronze (or clear anodized as approved by BCE)

Finish: Anodized

Model #: 2x4, slider or awning type

Other: Provide thermally broken frames.

UFGS: Section 08 41 13 Aluminum-Framed Entrances and Storefronts

D03.3.3. Thermal Mass

Applicable N/A

Number of base standards 1

Image Tool 250 x 188



Type: **Style 1 Interior Wall Material**

Applies to: Group 1 Group 2 Group 3 Group 4 Other

Mfr: Custom, TBD

Color: Brown, sandstone, or tan

Finish: Ground face

Model #: Coursed unit masonry

Other: 4" high CMU units preferred.

UFGS: Section 04 20 00 Unit Masonry

D03.3.4. Thermal Shading

Applicable N/A

Number of base standards 2

Image Tool 250 x 188



Type: **Style 1 Wall Devices**

Applies to: Group 1 Group 2 Group 3 Group 4 Other

Mfr: Kawneer (or equivalent) or custom

Color: Dark bronze, natural aluminum, or wall panel color

Finish: Factory

Model #: Louver/airfoil

Other: Shading devices may be attached to frames or structure

UFGS: Section 08 41 13 Aluminum-Framed Entrances and Storefronts



Type: **Style 2 Window Devices**

Applies to: Group 1 Group 2 Group 3 Group 4 Other

Mfr: Kawneer (or equivalent) or custom

Color: Dark bronze or natural aluminum

Finish: Factory, to match frames

Model #: Louver/airfoil

Other: Shading devices may be attached to frames or structure

UFGS: Section 08 41 13 Aluminum-Framed Entrances and Storefronts

D03.3.5. Renewable Heating/Cooling

Applicable N/A

Number of base standards 1

Image Tool 250 x 188

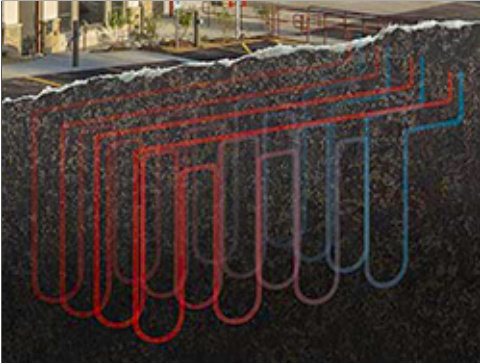

Type: **Style 1 Geothermal (Ground Source)**

Applies to: Group 1 Group 2 Group 3 Group 4 Other

Mfr: Climate Master

Color: N/A

Finish: N/A

Model #: N/A

Other: Vertical ground loop well field. Coordinate with BCE.
Creech AFB test well data indicated favorable conditions for Ground Source Heat Pump (GSHP) and should be considered when feasible.

UFGS: Section 23 81 47 Water-Loop and Ground-Loop Heat Pump Systems

D03.3.6. Solar Photovoltaic System

Applicable N/A

Number of base standards 2

Image Tool 250 x 188



Type: **Ground-Mounted PV Panels**

Applies to: Group 1 Group 2 Group 3 Group 4 Other

Mfr: TBD

Color: Factory

Finish: Matte

Model #: Flat plate collector, fixed or tracking

Other: Coordinate with BCE.

UFGS: Section 48 14 00 Solar Photovoltaic Systems

Type: **Roof-Mounted PV Panels**



Applies to: Group 1 Group 2 Group 3 Group 4 Other

Mfr: TBD

Color: Factory

Finish: Matte

Model #: Flat plate collector

Other: Coordinate with BCE. Roof mounted panels approved on a case basis. Preference is for installation of panels on steel structures in parking lot to provide vehicle shading and easier maintenance.

UFGS: Section 48 14 00 Solar Photovoltaic Systems

D03.3.7. Solar Thermal System

Applicable N/A Number of base standards 1

Image Tool 250 x 188



Type: **Wall-Mounted or Roof-Mounted Panels**

Applies to: Group 1 Group 2 Group 3 Group 4 Other

Mfr: TBD

Color: Factory

Finish: Matte

Model #: Flat plate collector

Other: Coordinate with BCE.

UFGS: Section 48 14 13 Solar Liquid Flat Plate and Evacuated Tube Collectors

D04. BUILDING ENTRANCES

Comply with AF Corporate Standards for Facilities Exteriors:

<http://afcs.wbdg.org/facilities-exterior/index.html>

Comply with AF Corporate Standards for Building Entrances:

<http://afcs.wbdg.org/facilities-exterior/building-entrances/index.html>

Insert 3 photos for each facility group.

Image Tool 250 x 188

Group 1



Group 2



Group 3



Group 4



D04.1. Primary Entrances

1. Emphasize the primary entrance in the overall building design with a projecting or recessed covering for weather protection and shading following Installation Facilities Standards (IFS) for Facility Group designations.
2. Provide vestibules at entries in Groups 1, 2 and 3 unless used infrequently or serving unconditioned space following ASHRAE 90.1.
3. Fully integrate all elements including the design of handicap ramps in the overall design of the primary entrance in an organized uncluttered appearance.
4. Install paved transitional spaces sized for the building function and occupancy.
5. Install appropriate lighting and site furniture following ATFP and IFS.
6. Protect entrances from direct sun. North-facing entrances are preferred.
7. Provide porte cocheres or covered drop-offs when justified for lodging and medical facilities; do not use for prestige or architectural accents.

D04.2. Secondary Entrances

1. Provide vestibules at entries in Groups 1, 2 and 3 unless used infrequently or serving unconditioned space following ASHRAE 90.1; use of stair towers as vestibules for multi-story buildings is encouraged when building and/or energy codes are satisfied.
2. Reflect the character of the primary entrance to a lesser extent with a smaller scale.
3. Include a recess or projection for weather protection and shading.
4. Integrate service and egress doors and loading areas with the building design by matching the materials and detailing and reflect the overall quality of the facility.
5. Incorporate egress structures such as stair towers into the facility design.
6. Canopies may be used for service and loading areas; weather protection beyond weather stripping is not required at doors used only for life safety egress.
7. Develop building massing and orientation to minimize the appearance of service and loading areas; physically and visually separate these from primary entrances.
8. Loading areas must be organized, orderly and have an uncluttered appearance.

D05. WALL SYSTEMS

Comply with AF Corporate Standards for Facilities Exteriors:

<http://afcs.wbdg.org/facilities-exteriors/index.html>

Comply with AF Corporate Standards for Doors and Windows:

<http://afcs.wbdg.org/facilities-exteriors/wall-systems/index.html>

Comply with AFCFS Recommended Materials:

<http://afcs.wbdg.org/facilities-exteriors/wall-systems/materials/index.html>

Insert 3 photos for each facility group.

Image Tool 250 x 188

Group 1



Group 2



Group 3

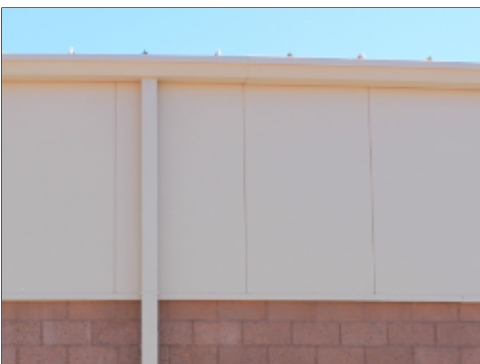

Group 4

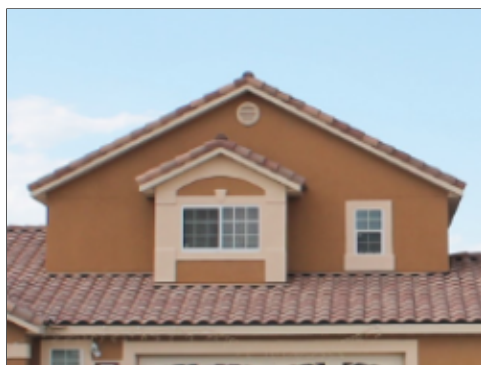

D05.1. Hierarchy of Materials

1. Group 1 facilities may have more refined detailing than Group 2, and Group 2 may have more definition than Group 3.
2. Group 1 and Group 2 facilities shall be predominately CMU and/or architectural metal panels. Architectural precast concrete may be used as an accent material. CMU may be split face, ground face or smooth face. Majority of CMU shall be split face.
3. Group 3 facilities shall be predominately insulated or uninsulated metal panels and/or structural CMU. CMU may be split face, ground face, or smooth face. Majority of CMU shall be split face.
4. Group 4 shall be traditional 3-coat stucco system.
5. Color of metal wall panels shall match Sherwin Williams color SW 7713 "Tawny Tan". In limited cases on smaller facilities and with BCE office approval, metal wall panel color may match Drexel Metals "Sierra Tan" (a standard color from various manufacturers). At Creech AFB, metal wall panel color may match Englert Metals "Sandstone" (a standard color from various manufacturers). On larger facilities, some areas may have dark brown wall panels as an accent color. USAF Thunderbirds facility may have white wall panels with red and blue accent colors. Provide Kynar-500 factory finish on all metal.
6. Multi-story facilities may include a transition in material, color or detailing to create a visual base. Generally, limit CMU to one field color and one accent color. CMU accents may have a variety of CMU finishes and unit heights.
7. Use high-performance building envelopes following UFC 1-200-02.
8. Use detailing not subject to excessive weathering. Provide wall accents consistently throughout the base.
9. Use integrally colored materials and factory-finished metals. Do not paint CMU. CMU and mortar shall have additives to prevent efflorescence.
10. Translucent insulated wall panels may be used in Facility Groups 1, 2 and 3. Protect from direct solar gain with shading appropriate for the orientation and exposure.
11. Manufacturers listed below are only provided to establish a baseline of equivalency among all applicable manufacturers.

D05.2. Layout, Organization and Durability

1. Organize wall components including doors, windows, accents, shading devices, control joints, etc., to provide an ordered, professional appearance.
2. Integrate shading devices into the overall composition of the wall.
3. Integrate fixed shading devices as at all exterior glazing exposed to summer UV heat gain as a passive design measure to reduce energy use. Ensure adequate shading at west entrances. Deciduous trees may be used for shading.
4. Shading systems may be included as part of a manufacturer's window system or may be custom systems integrated into the wall.
5. Provide appropriate transitions between dissimilar materials to mitigate effects of thermal expansion and galvanic action.
6. All joint sealants shall be slightly darker than adjacent surfaces.
7. Materials requiring regular maintenance are not permitted; do not use exposed structural steel or other materials that require painting.
8. Refer to C07.2.16. Screen Walls for materials and colors of freestanding walls.

9. Refer to D07. Roofs for downspouts.

D05.3. Equipment, Vents and Devices

1. Arrange all mechanical, electrical, fire alarm, lightning protection and other system components to create an orderly appearance that integrates with the wall system.
2. Do not expose conduits, cables, piping, lightning protection components, etc. on exterior walls; if unavoidable in renovations, finish these elements to match the adjacent wall surface.
3. Avoid visual clutter, and where surface-mounted elements are required they shall match the wall color.

D05.4 Wall Systems Materials

Facility Group 1 wall materials shall be as follows.

Primary: CMU or architectural metal panels

Secondary: Architectural precast

Accent: Alternate material color/finish

Facility Group 2 wall materials shall be as follows.

Primary: CMU or architectural metal panels

Secondary: Architectural precast

Accent: Alternate material color/finish

Facility Group 3 wall materials shall be as follows.

Primary: CMU or metal panels

Secondary: N/A

Accent: Alternate material color/finish

Facility Group 4 wall materials shall be as follows.

Primary: 3-coat stucco

Secondary: N/A

Accent: Stone veneer

Note: Apply the below base-wide standards for Wall Systems (products, materials and color). Then refer to the Appendix and apply any additional requirements specifically related to the Facility District in which the project is located.

D05.4.1. Flat Metal Panels

Applicable N/A

Number of base standards 3

Image Tool 250 x 188



Type: **Architectural Insulated Metal Panel System**

Applies to: Group 1 Group 2 Group 3 Group 4 Other

Mfr: Centria

Model #: Formawall Dimension Series

Color: Refer to IFS Section D05.1.5

Finish: Light stucco embossed factory finish

Other: Reveals at panel joints; no trim pieces at outside panel corners

UFGS: Section 07 42 13 Metal Wall Panels:
<http://www.wbdg.org/FFC/DOD/UFGS/UFGS 07 42 13.pdf>
Section 07 42 63 Fabricated Wall Panel Assemblies:
<http://www.wbdg.org/FFC/DOD/UFGS/UFGS 07 42 63.pdf>

Type: **Insulated Metal Panel System**

Applies to: Group 1 Group 2 Group 3 Group 4 Other

Mfr: Metl-Span

Model #: CF Santa Fe Insulated Metal Wall System

Color: Refer to IFS Section D05.1.5

Finish: Light stucco embossed factory finish

Other: Horizontal or vertical installation

UFGS: Section 07 42 13 Metal Wall Panels:
<http://www.wbdg.org/FFC/DOD/UFGS/UFGS 07 42 13.pdf>
Section 07 42 63 Fabricated Wall Panel Assemblies:
<http://www.wbdg.org/FFC/DOD/UFGS/UFGS 07 42 63.pdf>





Type: **Standing Seam Metal Panel**

Applies to: Group 1 Group 2 Group 3 Group 4 Other

Mfr: TBD

Model #: Appearance to match standing seam metal roof panel.

Color: Refer to IFS Section D07.4.1 and Section D05.1.5

Finish: matte, smooth

Other: Vertical installation

UFGS: Section 07 42 13 Metal Wall Panels:
<http://www.wbdg.org/FFC/DOD/UFGS/UFGS 07 42 13.pdf>
Section 07 42 63 Fabricated Wall Panel Assemblies:
<http://www.wbdg.org/FFC/DOD/UFGS/UFGS 07 42 63.pdf>

D05.4.2. Brick Veneer

Applicable N/A

D05.4.3. Architectural Precast

Applicable N/A Number of base standards 1

Image Tool 250 x 188



Type: **Precast Concrete**

Applies to: Group 1 Group 2 Group 3 Group 4 Other

Mfr: Local, TBD

Model #: Smooth Casting

Color: Brown, Sandstone, or Tan

Finish: Very Light texture

Other: N/A

UFGS: Section 03 45 00 Precast Architectural Concrete:
<http://www.wbdg.org/FFC/DOD/UFGS/UFGS 03 45 00.pdf>

D05.4.4. Stucco Over Sheathing

Applicable N/A

Number of base standards 1

Image Tool 250 x 188



Type: **3-Coat Cementitious Stucco**

Applies to: Group 1 Group 2 Group 3 Group 4 Other

Mfr: La Habra

Model #: Traditional 3-coat system

Color: natural earth tones, primary and accent colors

Finish: Sand

Other: May be used at roof soffit and eaves for Groups 1, 2 and 3.

UFGS: Section 09 24 23 Cement Stucco:

http://www.wbdg.org/FFC/DOD/UFGS/UFGS_09_24_23.pdf

D05.4.5. Curtain Wall

Applicable N/A

D05.4.6. Cast-In-Place Concrete

Applicable N/A

D05.4.7. Tilt-Up Concrete

Applicable N/A

D05.4.8. Ribbed Metal Sheeting

Applicable N/A Number of base standards 1

Image Tool 250 x 188



Type: **Lap Seam Panel**

Applies to: Group 1 Group 2 Group 3 Group 4 Other

Mfr: TBD

Model #: Lap Seam

Color: Refer to IFS Section D05.1.5

Finish: Factory Finish

Other: Horizontal or vertical installation

UFGS: Section 07 42 13 Metal Wall Panels:
<http://www.wbdg.org/FFC/DOD/UFGS/UFGS 07 42 13.pdf>

D05.4.9. EIFS

Applicable N/A Number of base standards 1

Image Tool 250 x 188

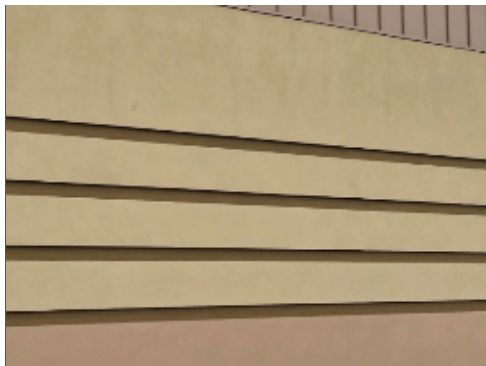

Type: **Exterior Insulation and Finish System**

Applies to: Group 1 Group 2 Group 3 Group 4 Other

Mfr: Dryvit

Model #: TBD

Color: Brown, Sandstone, or Tan

Finish: Sand

Other: Per BCE approval, may be used for building renovations/roof soffits

UFGS: Section 07 24 00 Exterior Insulation and Finish Systems:
<http://www.wbdg.org/FFC/DOD/UFGS/UFGS 07 24 00.pdf>

D05.4.10. GFRC

Applicable N/A

D05.4.11. Concrete Block

Applicable N/A

Number of base standards 4

Image Tool 250 x 188



Type: **Concrete Masonry Unit (CMU) Split Face**

Applies to: Group 1 Group 2 Group 3 Group 4 Other

Mfr: Local TBD

Model #: 8x8x16 Nominal, face and corner units

Color: Brown, Sandstone, or Tan

Finish: Heavy Texture

Other: N/A

UFGS: Section 04 20 00 Unit Masonry:
<http://www.wbdg.org/FFC/DOD/UFGS/UFGS 04 20 00.pdf>



Type: **Concrete Masonry Unit (CMU) Ground Face**

Applies to: Group 1 Group 2 Group 3 Group 4 Other

Mfr: Local TBD

Model #: 8x8x16 nominal, face and corner units

Color: Brown, Sandstone, or Tan

Finish: Ground/honed smooth with exposed aggregate

Other: N/A

UFGS: Section 04 20 00 Unit Masonry:
<http://www.wbdg.org/FFC/DOD/UFGS/UFGS 04 20 00.pdf>



Type: **Concrete Masonry Unit (CMU) Smooth Face**

Applies to: Group 1 Group 2 Group 3 Group 4 Other

Mfr: Local TBD

Model #: 8x8x16 nominal, face and corner units

Color: Brown, Sandstone, or Tan

Finish: Smooth with single vertical score in center

Other: 8" x 8" grid appearance

UFGS: Section 04 20 00 Unit Masonry:
<http://www.wbdg.org/FFC/DOD/UFGS/UFGS 04 20 00.pdf>



Type: **Concrete Masonry Unit (CMU) Fluted**

Applies to: Group 1 Group 2 Group 3 Group 4 Other

Mfr: Local TBD

Model #: 8x8x16 nominal, face and corner units

Color: Brown, Sandstone, or Tan

Finish: Fluted with split face ribs

Other: Overall depth of 10" nominal at flutes

UFGS: Section 04 20 00 Unit Masonry:
<http://www.wbdg.org/FFC/DOD/UFGS/UFGS 04 20 00.pdf>

D05.4.12. Fiber Cement Siding

Applicable N/A

D05.4.13. Other

Applicable N/A

D06. DOORS AND WINDOWS

Comply with AF Corporate Standards for Facilities Exteriors:

<http://afcs.wbdg.org/facilities-exterior/index.html>

Comply with AF Corporate Standards for Doors and Windows:

<http://afcs.wbdg.org/facilities-exterior/doors-and-windows/index.html>

Comply with AFCFS Recommended Materials:

<http://afcs.wbdg.org/facilities-exterior/doors-and-windows/materials/index.html>

Insert 3 photos for each facility group.

Image Tool 250 x 188

Group 1



Group 2



A photograph showing a close-up of a building's exterior. It features a white, slatted metal structure, possibly a balcony or a decorative element, set against a background of reddish-brown brickwork.

Group 3



Group 4

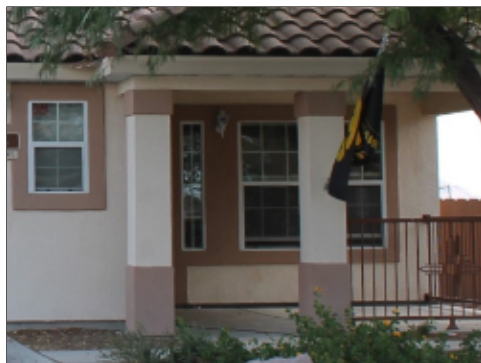

D06.1. Types

1. Use dark bronze or clear anodized aluminum doors, windows, and frames with thermal breaks. Door and frame color/finish shall match. For renovation projects, the color of new windows, doors, and frames may match the existing ones.
2. Aluminum clad wood windows are preferred for Facility Group 4.
3. Standard-sized hinged doors are preferred. Use sliding, folding, overhead, sectional and other door configurations only to support mission operations.
4. Automatic doors are allowed only where functionally necessary.
5. Limit hollow metal doors and frames to security doors, utility rooms and mechanical rooms in Groups 1 and 2 and to any application in Group 3 facilities.
6. Utility and emergency egress doors shall match the exterior wall color.
7. Passive thermal comfort methods of ventilation are encouraged where life-cycle cost justified.
8. Doors and windows shall meet force protection and antiterrorism requirements.
9. Adjacent joint sealants should be slightly darker than the frame color.
10. Manufacturers listed below are only provided to establish a baseline of equivalency among all applicable manufacturers.

D06.2. Layout and Geometry

1. Visually and functionally compose openings in walls for the climate-specific exposure. Recessed openings are encouraged to reduce solar gain. Window units should be set back from face of exterior wall surface a minimum of 2 inches.
2. Consistently use opening type, size, placement, mullion pattern, and color to reinforce the overall architectural design.
3. Openings shall augment interior lighting and space conditioning needs.
4. Protect against vandalism and intrusion and coordinate sound ratings.

D06.3. Glazing and Shading

1. Tinted, energy-efficient, low-e, double-pane glazing is required; provide triple-pane glazing in extreme environments.
2. Glazing color shall follow Installation Facilities Standards (IFS).
3. Translucent wall panels may be integrated into wall systems. Panel frame shall be clear anodized aluminum.
4. Do not use mirrored glazing.
5. Fully integrate applicable shading designs for overhangs, louvers, light shelves, and grilles.
6. Where appropriate, install window screens to take advantage of natural ventilation.

D06.4. Hardware

1. Provide hardware appropriate for the Facility Group while considering activity and frequency of use and climate; hardware may be of higher visual quality for Facility Group 1.
2. Ensure hardware will perform throughout the facility's lifespan without showing extreme wear.
3. Select finishes that will not degrade by intensity of operation or exposure to the elements.
4. Use consistent finishes and color on window and door systems throughout a facility. For renovation projects the color of new hardware may match the existing hardware.

5. Exterior and Interior locksets shall be BMHA Series 4000m Grade 1 with removable cores. Locks shall be "Best" brand or "Best" compatible. Cylinders and cores shall be interchangeable and have 7-pin tumblers. Provide "A" keyway at Nellis AFB and "G" keyway at Creech AFB.
6. Secured facilities shall have door hardware and door assemblies that meet requirements of the applicable security regulations. Sensitive Compartmented Information Facilities (SCIF) shall meet requirements of the Intelligence Community Standard 705-1 and 705-2 and the Intelligence Community Technical Specification for ICD/ICS 705.
7. Design building systems to eliminate the need for security screens whenever possible.

D06.5. Doors and Windows Materials

Note: Apply the below base-wide standards for Doors and Windows (products, materials and color). Then refer to the Appendix and apply any additional requirements specifically related to the Facility District in which the project is located.

D06.5.1. Anodized Aluminum

Applicable N/A Number of base standards 1

Image Tool 250 x 188



Type: **Anodized Aluminum Doors, Windows and Frames**

Applies to: Group 1 Group 2 Group 3 Group 4 Other

Mfr: Kawneer (or equivalent)

Color: Natural aluminum or dark bronze

Finish: Clear anodized aluminum

Model #: 2x4, thermally broken framing

Other: Group 1 may use larger openings with larger framing sections

UFGS: Section 08 41 13 Aluminum-Framed Entrances and Storefronts:
<http://www.wbdg.org/FFC/DOD/UFGS/UFGS 08 41 13.pdf>

D06.5.2. Hollow Metal

Applicable N/A

Number of base standards 1

Image Tool 250 x 188



Type: **Hollow Metal Doors, Windows and Frames**

Applies to: Group 1 Group 2 Group 3 Group 4 Other

Mfr: Steelcraft

Color: SW 7713 "Tawny Tan" or Drexel Metals "Sierra Tan"

Finish: Powder Coat, Satin

Model #: 2x4, thermally broken framing

Other: Group 1 use only for secondary entrances or emergency egress.

UFGS: Section 08 11 13 Steel Doors and Frames:

<http://www.wbdg.org/FFC/DOD/UFGS/UFGS 08 11 13.pdf>

D06.5.3. Aluminum-clad Wood

Applicable N/A

Number of base standards 1

Image Tool 250 x 188



Type: **Aluminum-clad Residential**

Applies to: Group 1 Group 2 Group 3 Group 4 Other

Mfr: Marvin

Color: White or light Earth tones

Finish: Powder coat, Satin

Model #: Aluminum-clad wood doors and windows

Other: Double hung windows

UFGS: Section 08 14 00 Wood Doors

<http://www.wbdg.org/FFC/DOD/UFGS/UFGS 08 14 00.pdf>

D06.5.4. Other

Applicable N/A

D07. ROOF SYSTEMS

Comply with AF Corporate Standards for Facilities Exteriors:

<http://afcs.wbdg.org/facilities-exteriors/index.html>

Comply with AF Corporate Standards for Roof Systems:

<http://afcs.wbdg.org/facilities-exteriors/roof-systems/index.html>

Comply with AFCFS Recommended Materials:

<http://afcs.wbdg.org/facilities-exteriors/roof-systems/materials/index.html>

Insert 3 photos for each facility group.

Image Tool 250 x 188

Group 1



Group 2

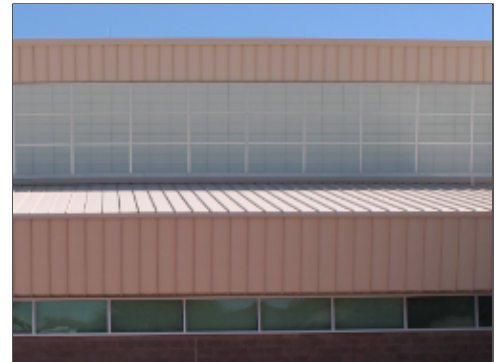

Group 3



Group 4



D07.1. Roof Type and Form

1. Use proven, cost-effective roof systems with high durability, weather resistance, and low maintenance that are compatible with Installation Facilities Standards (IFS) and requirements for the designated Facility Group.
2. Generally match the roof type and form of existing adjacent facilities in new construction.
3. Group 1, 2, and 3 buildings shall have sloped standing seam metal roof (SSMR) system or minimal sloped single-ply membrane system (EPDM or TPO). Some buildings may have sloped concrete tile. Roof system selected shall be based on facility's location, size, desired appearance, and geometry. SSMR and concrete tile roofs typically have overhangs and membrane roofs typically have parapets.
4. Group 4 buildings shall have concrete tile.
5. Provide visual screens for roof-mounted appendages and equipment. Screen material shall match SSMR roof or match/complement exterior wall material.
6. Minimal sloped roofs are typically used for larger facilities or to match existing conditions on an expansion project. Larger facilities may have a combination of SSMR and minimal slope roof system.
7. Roof eaves and soffits shall be factory finish metal. In some cases stucco or EIFS material may be allowed.
8. Roof eaves shall extend beyond the exterior wall for roof drainage and shading. Provide overhangs for shading in response to Mojave Desert conditions, sized and proportioned to the height of the facility and to the window openings being shaded. Eaves shall coordinate with adjacent wall-mounted shading devices.
9. Keep roofs uncluttered and minimize penetrations.
10. Diminish massive roofs into coordinated smaller components consistent with adjacent facilities; avoid random, arbitrary changes.
11. Increase the insulation value of existing roofing systems during renovations if supported by life-cycle cost and structural analysis.
12. Roofs shall be maintained for the life of the system and replaced in accordance with UFC 3-110-04 and AFI 32-1051. A warranty shall be provided for all roof installations.
13. Manufacturers listed below are only provided to establish a baseline of equivalency among all applicable manufacturers.

D07.2. Roof Slope

1. SSMR should generally have a 3:12 slope. Slope may be less or greater depending on building design.
2. Concrete tile roofs shall have a 3:12 slope. In some cases slope may be greater.
3. Minimal sloped roofs with membrane material shall have an appropriate slope for drainage and as required for roof assembly warranty.
4. Ensure adequate drainage, and connect to the subsurface rain collection system where available.
5. Provide appropriate roof slopes to accommodate solar photovoltaic, solar thermal, and passive systems when applicable following UFC 1-200-02.
6. Provide underlayments as required for the roofing type as directed by the UFC.

D07.3. Parapets and Copings

1. Extend wall materials vertically above the roof line and provide metal copings to match exterior wall. Ensure copings are properly flashed and detailed to avoid roof leaks.

D07.4. Color and Reflectivity

1. Color of SSMR shall match Sherwin Williams color SW 7713 "Tawny Tan". In limited cases on smaller facilities and with BCE office approval, SSMR color may match Drexel Metals "Sierra Tan" (a standard color from various manufacturers). At Creech AFB, SSMR color may match Englert Metals "Sandstone" (a standard color from various manufacturers). Provide Kynar-500 factory finish on all metal.
2. Concrete tile shall match Boral Saxony 900 Slate product, color "Desert Terra Cotta" or "Desert Sage".
3. Minimal slope membrane roofs shall use only use high-albedo, high reflectivity color to help decrease the temperature around the buildings and minimize damage to human and wildlife habitat.
4. Comply with UFC 3-110-03 and ASHRAE 90.1 for Solar Reflectance Index (SRI) and thermal requirements.
5. All roof flashing shall match the color of the predominant background material and have a factory finish.

D07.5. Gutters, Downspouts, Scuppers, Drains

1. Sloped roofs shall have gutters where appropriate.
2. Internal roof drainage systems are generally not permitted. Minimal sloped roofs shall be sloped to drain to the building perimeter through scuppers into downspouts.
3. Gutters, fascia, trim, and metal soffit panels on SSMR roofs shall match metal roof color. Provide Kynar-500 factory finish on all metal.
4. Gutters, fascia, trim and soffit color on concrete tile roofs shall match Drexel Metals "Sierra Tan". Dormitory buildings may have "Dark Bronze" color.
5. Size roof drainage system per IBC and SMACNA for the region.
6. Use scuppers as required in parapet walls.
7. Integrate downspouts and scuppers with the architectural details of the wall system and arrange in an orderly, non-prominent appearance.
8. Fabricate downspouts and scuppers from non-corrosive materials such as aluminum or zinc-coated steel and provide Kynar-500 factory finish. Downspouts shall be solid.
9. Downspouts and scuppers on metal panel walls shall match color of metal panels. Downspouts and scuppers on CMU walls shall match Drexel Metals "Sierra Tan" color.
10. Provide angled transitional pieces for downspouts to fit closely against the wall for their entire length.
11. Coordinate locations of downspouts to conceal control joints in masonry walls when possible.
12. Place downspouts away from building entries. Water discharged should not run across sidewalks.

D07.6. Roof Vents and Elements

1. Minimize and consolidate roof penetrations into a single, inconspicuous point whenever possible.
2. On sloped roofs clad pipe penetrations to match the roofing material.

3. Roof mounted mechanical equipment is prohibited. However for some renovation projects and unavoidable configurations, roof equipment may be allowed on a case basis per BCE office approval.
4. All roof equipment shall be screened from view and easily accessible for maintenance. Provide access points and service routes to equipment that protect the roof.
5. Screen all large vents.
6. Ensure attic spaces are properly vented at ridges and soffits.. Match roof color for all exposed equipment and vents. Avoid roof-mounted antenna systems.
7. Match roof color for all exposed equipment and vents.
8. Avoid roof mounted antenna systems.
9. Arrange Lightning Protection Systems (LPS) components in an ordered, uncluttered, inconspicuous appearance and integrated into the organization of the roof and wall systems.
10. Ensure that LPS roof mounting systems are approved by the roofing manufacturer.
11. Additions to a roof shall not interfere with LPS or other rooftop systems that may be required.
11. Permanent fall protection will be considered with any new roof with a slope steeper than 3:12 per UFC 3-110-03.

D07.7. Clerestories and Skylights

1. Translucent panelized wall system clerestories and tubular daylight-type skylights are permitted in Group 1, 2 and 3 facilities. These are allowed in Group 3 facilities only when serving passive systems and are justifiable by life-cycle cost analysis.
2. Clerestories are preferred to skylights to avoid roof penetrations. Skylights, when permitted, must be simple in shape and integrated with the roof system to eliminate leakage.
3. Design clerestories and skylights using the same principles for seasonal shading that are required for walls and roof overhangs.
4. Translucent panelized wall system clerestories are preferred to standard glass clerestories due to less maintenance required.
5. Translucent panelized wall system framing shall be aluminum and have natural clear aluminum color. Panel color shall be white or off-white.
6. Clerestories and skylights shall comply with UFC 4-10-01.

D07.8. Vegetated Roof

Not applicable.

D07.9. Roof Systems Materials

Note: Apply the below base-wide standards for Roof Systems (products, materials and color). Then refer to the Appendix and apply any additional requirements specifically related to the Facility District in which the project is located.

D07.9.1. Standing Seam Metal

Applicable N/A

Number of base standards 1

Image Tool 250 x 188



Type: **Shed, Gabled, or Hip Standing Seam Metal Roof (SSMR)**

Applies to: Group 1 Group 2 Group 3 Group 4 Other

Mfr: TBD

Color: Refer to IFS Section D07.4.1

Finish: Matte, smooth

Model #: TBD

Other: 22 gauge thickness min.
25 year min. warranty

UFGS: Section 07 61 14 Steel Standing Seam Roofing
<http://www.wbdg.org/FFC/DOD/UFGS/UFGS 07 61 14.00 20.pdf>

D07.9.2. Membrane Single-ply

Applicable N/A

Number of base standards 1

Image Tool 250 x 188



Type: **TPO or EPDM**

Applies to: Group 1 Group 2 Group 3 Group 4 Other

Mfr: TBD

Color: White or Off-white

Finish: Smooth

Model #: TBD

Other: TPO (Thermoplastic Polyolefin): 20 year min warranty; .080" min. thick
EPDM: 20 year min. warranty; fiber reinforced; mechanically fastened;
.060" minimum thickness

UFGS: Section 07 53 23 Ethylene-Propylene-Diene-Monomer Roofing
<http://www.wbdg.org/FFC/DOD/UFGS/UFGS 07 53 23.pdf>
Section 07 54 50 TPO Thermoplastic Single-Ply Roofing
(Not Available on UFGS)

D07.9.3. Built-up Multi-ply

Applicable N/A

D07.9.4. Concrete Tile

Applicable N/A

Number of base standards 1

Image Tool 250 x 188



Type: **Concrete Roof Tile**

Applies to: Group 1 Group 2 Group 3 Group 4 Other

Mfr: Boral

Color: Saxony 900 Slate: "Desert Terra Cotta" or "Desert Sage"

Finish: Factory

Model #: Saxony 900 Slate

Other: Standard Weight
25 year min. warranty including underlayment

UFGS: Section 07 32 16 Concrete Roof Tile
(Not Available on UFGS)

D07.9.5. Clay Tile

Applicable N/A

D07.9.6. Slate Shingles

Applicable N/A

D07.9.7. Vegetated System

Applicable N/A

D07.9.8. Ribbed Metal Sheeting

Applicable N/A

D07.9.9. Composite Shingles

Applicable N/A

Number of base standards 1

Image Tool 250 x 188



Type: **Shed, Gabled, or Hip Shingle Roof**

Applies to: Group 1 Group 2 Group 3 Group 4 Other

Mfr: TBD

Color: Earth Tones

Finish: Factory

Model #: TBD

Other: Composite shingles shall only be used in repair projects, not new construction. 20 year min. warranty.

UFGS: Section 07 31 13 Glass-fiber-reinforced Asphalt Shingles
<http://www.wbdg.org/FFC/DOD/UFGS/UFGS 07 31 13.pdf>

D07.9.10. Other

Applicable N/A

D08. STRUCTURAL SYSTEMS

Comply with AF Corporate Standards for Facilities Exteriors:

<http://afcf.wbdg.org/facilities-exterior/index.html>

Comply with AF Corporate Standards for Structural Systems:

<http://afcf.wbdg.org/facilities-exterior/structural-systems/index.html>

Comply with AFCFS Recommended Materials:

<http://afcf.wbdg.org/facilities-exterior/structural-systems/materials/index.html>

Insert 3 photos for each facility group.

Image Tool 250 x 188

Group 1



Group 2



Group 3



Group 4



D08.1. Systems and Layouts

1. Pre-engineered structural steel framing may be used for Groups 1, 2 and 3 facilities; Installation-appropriate thermal envelopes, materials and detailing are required.
2. Select economical structural systems that integrate roof and wall systems.
3. Narrow buildings 60' or less in width with column-free interiors are preferred for office, administrative and personnel spaces; when interior columns are required optimize the structural grid layout for open-plan arrangements.
4. Fully coordinate structural grids with exterior window systems to align columns with window frames or wall systems.
5. When structure is exposed provide an organized appearance and coordinate with mechanical, electrical, plumbing, fire protection, information technology, and communications systems.
6. Limit the use of specialty systems (such as space frames, vaults or domes) and of structure as a visual feature.
7. Cost-effectively design interior bearing walls as thermal mass.
8. Manufacturers listed below are only provided to establish a baseline of equivalency among all applicable manufacturers.

D08.2. Structural Systems Materials

Note: Apply the below base-wide standards for Structural Systems (products, materials and color). Then refer to the Appendix and apply any additional requirements specifically related to the Facility District in which the project is located.

D08.2.1. Concrete

Applicable N/A

Number of base standards 1

Image Tool 250 x 188



Type: **Concrete Framing**

Applies to: Group 1 Group 2 Group 3 Group 4 Other

Mfr: TBD

Color: Natural gray

Finish: Light texture

Model #: TBD

Other: N/A

UFGS: Section 03 30 53 Miscellaneous Cast-In-Place Concrete
<http://www.wbdg.org/FFC/DOD/UFGS/UFGS 03 30 53.pdf>
Section 03 33 00 Cast-In-Place Architectural Concrete
<http://www.wbdg.org/FFC/DOD/UFGS/UFGS 03 33 00.pdf>
Section 03 47 13 Tilt-Up Concrete
<http://www.wbdg.org/FFC/DOD/UFGS/UFGS 03 47 13.pdf>

D08.2.2. Insulated Concrete Forming (ICF)

Applicable N/A

Number of base standards 1

Image Tool 250 x 188



Type: **Concrete Wall**

Applies to: Group 1 Group 2 Group 3 Group 4 Other

Mfr: TBD

Color: White

Finish: Smooth

Model #: TBD

Other: N/A

UGFS: Section 03 30 53 Miscellaneous Cast-In-Place Concrete
<http://www.wbdg.org/FFC/DOD/UGFS/UGFS 03 30 53.pdf>
Section 03 11 19 Insulating Concrete Forming
(Not Available on UFGS)

D08.2.3. Steel

Applicable N/A

Number of base standards 1

Image Tool 250 x 188



Type: **Rigid Framing**

Applies to: Group 1 Group 2 Group 3 Group 4 Other

Mfr: TBD

Color: Shop primed

Finish: Matte

Model #: Structural steel shapes

Other: N/A

UGFS: Section 05 12 00 Structural Steel
<http://www.wbdg.org/FFC/DOD/UGFS/UGFS 05 12 00.pdf>

D08.2.4. Pre-Engineered Steel

Applicable N/A

Number of base standards 1

Image Tool 250 x 188



Type: **Moment Frame**

Applies to: Group 1 Group 2 Group 3 Group 4 Other

Mfr: TBD

Color: Factory primed

Finish: Matte

Model #: TBD

Other: N/A

UFGS: Section 13 12 00 Steel Building Systems
(Not Available on UFGS)
Section 13 34 19 Metal Building Systems
http://www.wbdg.org/FFC/DOD/UFGS/UFGS_13_34_19.pdf

D08.2.5. Masonry

Applicable N/A

Number of base standards 1

Image Tool 250 x 188

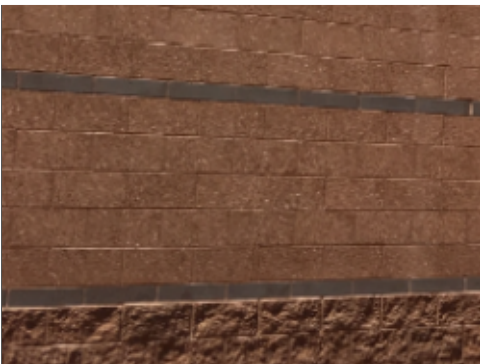

Type: **Concrete Masonry Unit (CMU)**

Applies to: Group 1 Group 2 Group 3 Group 4 Other

Mfr: TBD

Color: Exposed: Brown, Tan, Sandstone. Unexposed: Gray

Finish: Split Face, Smooth Face, Honed Face, Fluted

Model #: TBD

Other: See IFS Section D05.4.11 for exposed CMU

UFGS: Section 04 20 00 Unit Masonry
http://www.wbdg.org/FFC/DOD/UFGS/UFGS_04_20_00.pdf

D08.2.6. Heavy Timber

Applicable N/A

D08.2.7. Light-gauge Steel

Applicable N/A

Number of base standards 1

Image Tool 250 x 188



Type: **Steel Framing**

Applies to: Group 1 Group 2 Group 3 Group 4 Other

Mfr: Steelrite

Color: Factory

Finish: Galvanized

Model #: Structural framing shapes

Other: N/A

UFGS: Section 05 45 00 Light Gauge Steel Framing System
(Not Available on UFGS)

D08.2.8. Lumber Framing

Applicable N/A

D08.2.9. Other

Applicable N/A

D09. MECHANICAL, ELECTRICAL AND PLUMBING

Comply with AF Corporate Standards for Facilities Exteriors:

<http://afcf.wbdg.org/facilities-exterior/index.html>

Comply with AF Corporate Standards for Mechanical, Electrical and Plumbing:

<http://afcf.wbdg.org/facilities-exterior/mechanical-electrical-and-plumbing/index.html>

Insert 3 photos for each facility group.

Image Tool 250 x 188

Group 1



Group 2



Group 3



Group 4

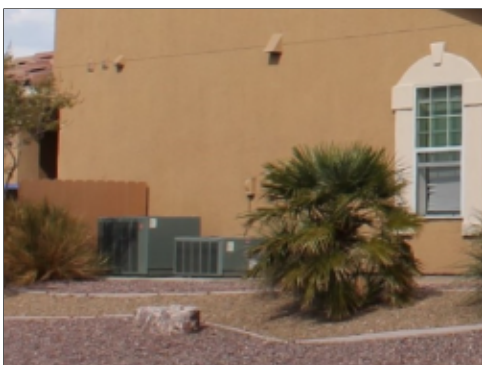

D09.1. Passive and Active Systems

1. Comply with Mechanical, Plumbing, Electrical, Lighting, Fire Protection, and Telecommunication requirements listed in Section G Appendix.
2. Fully integrate passive heating and cooling systems into facility designs whenever practical for the desert climate prior to the design of active mechanical systems.
3. Provide optimized passive and active systems; design active mechanical systems to supplement thermal mass walls and floors.
4. Develop renewable energy systems including geo-exchange (ground source heat pumps) when life-cycle cost effective.
5. Performance display screens, which report energy performance and utility savings, are encouraged; when provided locate these in building lobbies or common areas.
6. Solar domestic hot water systems are required when life-cycle cost effective for the climate.
7. Integrate shading into building exteriors to reduce solar heat gain during hot seasons.

D09.2. Functionality and Efficiency

1. Fully coordinate mechanical, electrical, plumbing, and fire protection systems with each other and with the building structure, enclosure, thermal envelope and interior design.
2. Provide direct exterior access to main mechanical and electrical rooms.
3. Screen exterior equipment from primary views (landscape, building masses, screen walls) and comply with ATEP requirements.
4. Keep equipment away from main building entrances; locate service area/yard on least visible side of a building.
5. Design emergency generator systems integrally with all other building systems and avoid incompatible building additions; locate generators near service areas and ensure they are not visible from primary entrances.
6. When structure is exposed as a finished ceiling, fully integrate MEP and fire protection systems to provide an organized uncluttered appearance.
7. Conceal ducts, piping, conduits, devices, etc., when permanent walls, suspended ceilings or raised floors are provided; locate fire sprinkler heads in orderly configuration.
8. Limit interior wall-mounted equipment in occupied personnel spaces; avoid surface-mounted conduit and pipes.
9. Provide efficient mechanical and electrical rooms with layouts to facilitate system performance and maintenance; provide convenient access to controls, clearly label systems and include operating and maintenance instructions.
10. Separate mechanical, electrical and communications rooms.
11. Integrate recessed and wall-mounted fixtures such as fire standpipe cabinets and drinking fountains within permanent walls. Provide integrated bottle filling stations at all drinking fountains.
12. Building systems in secured facilities shall meet requirements of the applicable security regulations. Sensitive Compartmented Information Facilities (SCIF) shall meet requirements of the Intelligence Community Standard 705-1 and 705-2 and the Intelligence Community Technical Specification for ICD/ICS 705. This includes facility perimeter construction, openings, mechanical, electrical, communications, security, and fire protection systems.
13. Provide electrical, water, and natural gas meters and connections that fully support the base's Advanced Meter Reading System (AMRS) and Automated Revenue Management Services (ARMS). Comply with Utility Meter Requirements listed in Section G Appendix.

E. FACILITIES INTERIORS

Comply with Air Force Corporate Standards for Facilities Interiors:
<http://afcs.wbdg.org/facilities-interiors/index.html>

Insert 3 photos for each facility group.

Image Tool 250 x 188

Group 1

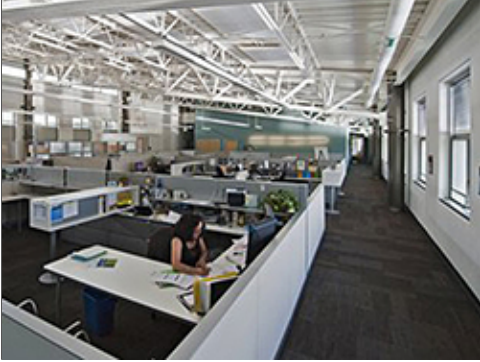

Group 2

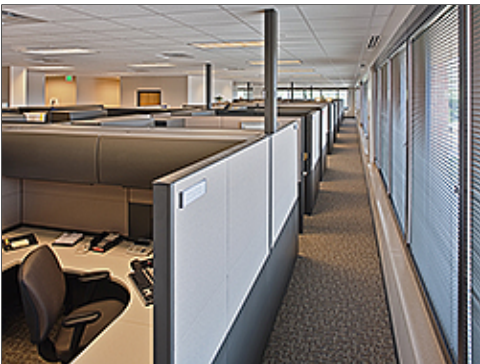

Group 3



Group 4



E01. Building Configurations

Comply with Air Force Corporate Standards for Building Configurations:

<http://afcfs.wbdg.org/facilities-interiors/buildings-configurations/index.html>

1. Provide open-plan configurations for office, administrative, operational and related activities and spaces for maximum flexibility. Use a “core and shell” approach in which all building systems, infrastructure and permanent interior partitions anticipate two or more uses (operations) during a facility's lifespan.
2. Create flexible interior configurations using Furniture, Fixtures & Equipment (FF&E) and limit private offices and private rooms. Refer to AFMAN 32-1084 for space requirements. To the greatest extent, limit permanent partitions to core areas such as toilet rooms, stairs, mechanical and utility rooms.
3. Use more durable long-lasting finishes in core areas for walls, ceilings, floor coverings and built-in casework. Coordinate interior FF&E layouts with structural grids during space planning.
4. Provide high-performance building configurations following UFC 1-200-02. Ensure passive design strategies are cost effectively incorporated before active mechanical systems are designed.
5. Comply with Electrical, Lighting, Fire Protection, Telecommunication, Mechanical, and Plumbing requirements listed in Section G Appendix.
6. Comply with UFC 1-200-01, general building requirements. UFC 1-200-01 provides applicability of model building codes and government unique criteria for typical design disciplines and building systems, as well as for accessibility, antiterrorism, security, high performance and sustainability requirements, and safety.
7. Meet security and force protection requirements in UFC 4-010-01: DoD Minimum Antiterrorism Standards for Buildings.
8. Comply with AFCFS for supporting mission requirements, addressing human comfort and well being, and creating highly flexible interiors while satisfying metrics for high performance and sustainable buildings.
9. Provide a level of quality for interior features, materials and finishes that is appropriate for the Facility Group number. Group 1 may receive higher quality than Groups 2 thru 4. Refer to Facility Hierarchy.
10. Through open-plan configurations, preserve all passive and natural design strategies and fully integrate facility interiors with overall building systems.
11. Professional interior designers, or architects with significant interior design experience, must accomplish the design and review of applicable new construction, renovations and maintenance projects.
12. Consult with the State Historic Preservation Officer (SHPO) and base-level Historic Preservation offices regarding proposed changes to properties listed on or eligible for listing on the National Register of Historic Places. Follow requirements of The National Historic Preservation Act and Secretary of the Interior Standards for the Treatment of Historic Properties.
13. Maintain architectural compatibility following AFCFS and this Installation Facilities Standards (IFS) document to create continuity while avoiding monotony.

E01.1. Layout and Common Areas

Comply with Air Force Corporate Standards for Layout and Common Areas:

<http://afcfs.wbdg.org/facilities-interiors/buildings-configurations/layout-and-common-areas/index.html>

1. Create open-plan interior environments to accommodate changes.
2. Limit interior partitions, private offices and rooms; use furniture or modular systems to provide privacy and acoustic control.
3. When partitions are functionally justified such as for conference rooms, use systems furniture and moveable (demountable) floor-to-ceiling wall systems for acoustical or visual privacy.

4. Proportion lobbies and common spaces based on type of function, activity and facility group.
5. Allow no direct sight lines into restrooms.
6. Situate utility and core areas to minimize impact on daylighting and to maximize use as thermal buffers.
7. Ensure electrical, lighting and communications system can be adaptable to configuration changes.
8. Avoid power poles to the maximum extent; when poles are necessary minimize the number and coordinate locations with furniture placement and other elements.
9. Avoid sloping floors to maintain flexibility and eliminate future structural changes.
10. Special consideration may apply to Sensitive Compartmented Information Facilities (SCIFs).

E01.1.1. Interior Design Process

1. Comply with UFC 3-120-10 for the Comprehensive Interior Design (CID,) which includes both Structural Interior Design (SID) and Furniture, Fixtures & Equipment (FF&E) design services.
2. Use a collaborative, integrated planning and design team, composed of user, government support staff, and appropriate professionals. Integrate architectural features using simple detailing to create a professional appearance; avoid extravagant or excessive detailing.
3. Ensure interior designs satisfy the functional requirements within the context of flexibility, sustainability and the building's energy performance.
4. Base space planning on square foot allocations from AFM 32-1084. Identify special requirements if any, such as privacy separation, VIP areas, gathering spaces and storage. Note: The occupant's rank and position will influence the square footage and selection of materials.
5. Provide clear circulation and pathway finding for both horizontal and vertical directions that accommodate the number of personnel in the facility.
6. Maximize efficiencies in the space plan for functional relationships and adjacencies for all facility users. Efficiently create and situate rooms and support rooms such as conference / meeting rooms and break rooms.
7. Provide interior design building-related illustrations, drawings, schedules, materials selections, specifications and cost estimates as listed in UFC 3-120-10. Refer to Furnishings in this IFS also.
8. SID shall follow UFC 3-120-10 Interior Design.
9. Base the FF&E package on the furniture footprint developed in the SID. Identify all new or existing equipment needed and its users within each facility or each area of the facility. Provide specific information on: equipment sizes, electrical requirements, ventilation requirements, weight (if heavy), quantity, and security level if required. Presume all administrative spaces have computers and supporting equipment.

E01.1.2. Codes and Regulations

1. Refer to UFC 1-200-01 for modifications to the International Building Code (IBC) to determine applicable sections of the IBC. Both the IBC Chapter 3 and UFC 3-600-01 govern "Use and Occupancy Classification" for example.
2. Fire code requirements shall be as defined in the International Building Code (IBC) and must be used where dictated by UFC 1-200-01 DoD Building Code (General Building Requirements) except where noted in UFC 3-600-01 (Fire Protection Engineering For Facilities).

3. National Fire Protection Association (NFPA) 101 must be utilized to determine the occupancy classification as it relates to fire/smoke resistance rating of interior non-load bearing partitions (other than occupancy separation), means of egress, interior finish, features of fire protection (including vertical openings) and associated requirements.

E01.2. Quality and Comfort

Comply with Air Force Corporate Standards for Quality and Comfort:

<http://afcs.wbdg.org/facilities-interiors/buildings-configurations/quality-and-comfort/index.html>

1. Include durability in the life-cycle cost analysis for best-value material selections with long life expectancies that do not show excessive wearing.
2. Select long-lasting materials and finishes for permanent core areas such as lobbies, restrooms and stairs.
3. Select low-maintenance materials and products that reduce ongoing servicing and repair and that are easy to clean.
4. Relate the visual quality of finishes to the Facility Group number.
5. Building and interior configurations should address both operations and climatic responses.
6. Convey a professional image; avoid trendy patterns and textures.
7. Use materials and finishes that provide a healthy indoor environment.
8. Orient interior spaces toward views while maintaining cost-effective building performance and efficiency.
9. Promote air movement and daylighting for human health and wellbeing.
10. In restrooms, provide light fixtures directly above lavatory sinks (wall mounted or recessed in ceiling).

E02. Floors

Comply with Air Force Corporate Standards for Floors:

<http://afcs.wbdg.org/facilities-interiors/floors/index.html>

E02.1. Floor Materials

Facility Group 1 floor materials shall be as follows.

Primary: Prepared Slabs (Ground, Polished)
 Secondary: Porcelain tile
 Tertiary: Carpet, Rubber Stair Treads

Facility Group 2 floor materials shall be as follows.

Primary: Prepared Slabs (Ground, Polished)
 Secondary: Porcelain or Ceramic tile
 Tertiary: Carpet, Rubber Stair Treads

Facility Group 3 floor materials shall be as follows.

Primary: Prepared Slabs (Ground)
 Secondary: Ceramic Tile
 Tertiary: N/A

Facility Group 4 floor materials shall be as follows.

Primary: Carpet
 Secondary: Ceramic tile
 Tertiary: N/A

1. Resilient and rapidly renewable flooring may be used in low traffic areas in Group 1, 2 and 4.

2. Manufacturers listed below are only provided to establish a baseline of equivalency among all applicable manufacturers.

Note: Apply the below base-wide standards for Floors (products, materials and color). Then refer to the Appendix and apply any additional requirements specifically related to the Facility District in which the project is located.

E02.1.1. Prepared Slabs

Applicable N/A

Number of base standards 2

Image Tool 250 x 188



Type: **Style 1, Ground and Polished**

Applies to: Group 1 Group 2 Group 3 Group 4 Other

Mfr: Local (TBD)

Color: Natural gray cement, light to dark beige aggregates

Finish: Fine polished texture

Model #: Medium to small aggregate

Other: N/A

UFGS: Section 03 35 45 Polished Concrete Finishing
(Not Available on UFGS)

Type: **Style 2, Ground and Polished**

Applies to: Group 1 Group 2 Group 3 Group 4 Other

Mfr: Local (TBD)

Color: Natural gray cement, light to dark beige aggregates

Finish: Medium polished texture, slip resistant

Model #: Medium to small aggregate

Other: N/A

UFGS: Section 03 35 45 Polished Concrete Finishing
(Not Available on UFGS)



E02.1.2. Natural Stone and Terrazzo

Applicable N/A

E02.1.3. Quarry Tile

Applicable N/A

Number of base standards 1

Image Tool 250 x 188



Type: **Style 1**

Applies to: Group 1 Group 2 Group 3 Group 4 Other

Mfr: Daltile

Color: Earth tones

Finish: Matte, slip resistant

Model #: N/A

Other: Use in commercial kitchen flooring.

UFGS: Section 09 30 10 Ceramic, Quarry, and Glass Tiling
<http://www.wbdg.org/FFC/DOD/UFGS/UFGS 09 30 10.pdf>

E02.1.4. Ceramic Tile

Applicable N/A

Number of base standards 2

Image Tool 250 x 188



Type: **Style 1 Porcelain**

Applies to: Group 1 Group 2 Group 3 Group 4 Other

Mfr: Daltile

Color: Earth tones

Finish: Matte, slip resistant

Model #: Porcelain tile

Other: Use in high traffic areas. Epoxy grout is recommended.

UFGS: Section 09 30 10 Ceramic, Quarry, and Glass Tiling
<http://www.wbdg.org/FFC/DOD/UFGS/UFGS 09 30 10.pdf>

Type: **Style 2 Ceramic**



Applies to: Group 1 Group 2 Group 3 Group 4 Other

Mfr: Daltile

Color: Earth tones

Finish: Matte, slip resistant

Model #: Ceramic tile

Other: Use in low traffic area toilet rooms.

UFGS: Section 09 30 10 Ceramic, Quarry, and Glass Tiling
<http://www.wbdg.org/FFC/DOD/UFGS/UFGS 09 30 10.pdf>

E02.1.5. Resilient Floor

Applicable N/A Number of base standards 1

Image Tool 250 x 188



Type: **Style 1 Stair Treads**

Applies to: Group 1 Group 2 Group 3 Group 4 Other

Mfr: Roppe

Color: Neutral tones

Finish: Factory

Model #: Raised design rubber tread

Other: Stair treads material

UFGS: Section 09 65 00 Resilient Flooring
<http://www.wbdg.org/FFC/DOD/UFGS/UFGS 09 65 00.pdf>

E02.1.6. Carpet

Applicable N/A

Number of base standards 2

Image Tool 250 x 188



Type: **Style 1**

Applies to: Group 1 Group 2 Group 3 Group 4 Other

Mfr: Mohawk Group

Color: Neutral multi-colored tones/patterned/solid

Finish: Yarn: Nylon 6 or 6.6/cut pile or loop pile

Model #: Broadloom, 6' wide rolled, carpet tiles, entry walk-off carpet

Other: N/A

UFGS: UFGS 09 68 00 Carpeting

<http://www.wbdg.org/FFC/DOD/UFGS/UFGS 09 68 00.pdf>

Type: **Style 2**

Applies to: Group 1 Group 2 Group 3 Group 4 Other

Mfr: Mohawk Group

Color: Earth tones

Finish: Factory

Model #: Broadloom, residential loop, "Smartstrand"

Other: N/A

UFGS: UFGS 09 68 00 Carpeting

<http://www.wbdg.org/FFC/DOD/UFGS/UFGS 09 68 00.pdf>

E02.1.7. Rapidly-Renewable Products

Applicable N/A

E02.1.8. Other

Applicable N/A

E03. Walls

Comply with Air Force Corporate Standards for Walls:
<http://afcs.wbdg.org/facilities-interiors/walls/index.html>

E03.1. Wall Materials

Facility Group 1 wall materials shall be as follows.

Primary: Gypsum board (painted)
Secondary: N/A
Tertiary: Ceramic tile (restrooms)

Facility Group 2 wall materials shall be as follows.

Primary: Gypsum board (painted)
Secondary: N/A
Tertiary: Ceramic tile (restrooms)

Facility Group 3 wall materials shall be as follows.

Primary: Gypsum board (painted)
Secondary: N/A
Tertiary: Ceramic tile (restrooms)

Facility Group 4 wall materials shall be as follows.

Primary: Gypsum board (painted)
Secondary: N/A
Tertiary: Ceramic tile (restrooms)

1. Follow UFC 3-450-01 (Vibration and Noise Control) for acoustic design issues including speech privacy, sound isolation or sound masking.
2. Select and apply paint with sheens (gloss levels) appropriate for the application following UFGS Section 09 90 00 Paints and Coatings.
3. Provide ceramic tile on wet walls of kitchens, toilet rooms, locker rooms, etc., in all facility groups. Provide ceramic tile on wall behind drinking fountains.
4. Group 1 and 2 high visibility areas may have ground face CMU, wood paneling, smooth architectural metal panels, or other durable higher quality material used on an accent wall.
5. Group 3 industrial areas requiring durability may have exposed smooth face CMU.
6. Provide rubber base on drywall partitions in Groups 1 and 2.
7. Hardwood base may only be used in Group 1 as approved on a case basis.
8. Hardwood chair rails / bumper rails may be used in high-use areas of Groups 1 and 2; aqueous clear finishes are preferred to reduce maintenance; plastic chair rails are permitted only in medical applications.
9. Decorative moldings may be used only in Group 1 when approved on a case basis.
10. Corner guards are permitted only in high traffic spaces with wheeled or cart use such as private service areas in Groups 1 and 2; stainless steel corners guards with a brushed finish may be judiciously used in Group 3.
11. Group 4 may use painted composite wood base.
12. Manufacturers listed below are only provided to establish a baseline of equivalency among all applicable manufacturers.

Note: Apply the below base-wide standards for Walls (products, materials and color). Then refer to the Appendix and apply any additional requirements specifically related to the Facility District in which the project is located.

E03.1.1. Concrete

Applicable N/A

E03.1.2. Masonry

Applicable N/A

Number of base standards 1

Image Tool 250 x 188



Type: **Ground Face CMU**

Applies to: Group 1 Group 2 Group 3 Group 4 Other

Mfr: Local (TBD)

Color: Brown or Tan

Finish: Honed Smooth

Model #: Coursed unit masonry

Other: 4 or 8 inch high unit used as accent walls.

UFGS: Section 03 33 00 Cast-In-Place Architectural Concrete
<http://www.wbdg.org/FFC/DOD/UFGS/UFGS 03 33 00.pdf>

E03.1.3. Ceramic Tile

Applicable N/A

Number of base standards 1

Image Tool 250 x 188



Type: **Style 1**

Applies to: Group 1 Group 2 Group 3 Group 4 Other

Mfr: Daltile

Color: Earth tones

Finish: Gloss, Semi-gloss

Model #: Ceramic wall tile

Other: Located on wet walls in restrooms, at drinking fountains, and on accent walls.

UFGS: Section 09 30 10 Ceramic, Quarry, and Glass Tiling
<http://www.wbdg.org/FFC/DOD/UFGS/UFGS 09 30 10.pdf>

E03.1.4. Gypsum Board

Applicable N/A

Number of base standards 1

Image Tool 250 x 188

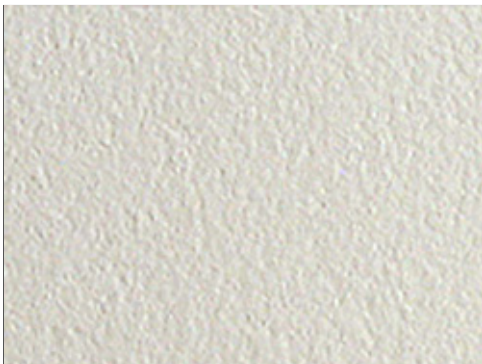

Type: **Style 1**

Applies to: Group 1 Group 2 Group 3 Group 4 Other

Mfr: US Gypsum

Color: Solid Earth tone colors

Finish: Paint (Sheen per UFGS)

Model #: Tapered edge

Other: N/A

UFGS: Section 09 29 00 Gypsum Board
<http://www.wbdg.org/FFC/DOD/UFGS/UFGS 09 29 00.pdf>
Section 09 90 00 Paints and Coatings
<http://www.wbdg.org/FFC/DOD/UFGS/UFGS 09 90 00.pdf>

E03.1.5. Metal Panels

Applicable N/A

E03.1.6. Wood Paneling

Applicable N/A

E03.1.7. Rapidly-Renewable Products

Applicable N/A

E03.1.8. Other

Applicable N/A

E04. Ceilings

Comply with Air Force Corporate Standards for Ceilings:
<http://afcs.wbdg.org/facilities-interiors/ceilings/index.html>

E04.1. Ceiling Materials

Facility Group 1 ceiling materials shall be as follows.

Primary: Exposed Framing (Roof / Floor Structure Above)
Secondary: Grid and Acoustical Tile
Tertiary: Gypsum board (painted)

Facility Group 2 ceiling materials shall be as follows.

Primary: Exposed Framing (Roof / Floor Structure Above)
Secondary: Grid and Acoustical Tile
Tertiary: Gypsum board (painted)

Facility Group 3 ceiling materials shall be as follows.

Primary: Exposed Framing (Roof / Floor Structure Above)
Secondary: Grid and Acoustical Tile
Tertiary: Gypsum board (painted)

Facility Group 4 ceiling materials shall be as follows.

Primary: Gypsum board (painted)
Secondary: N/A
Tertiary: N/A

1. Accent ceiling materials such as metal, wood, and rapidly renewable may be used in Group 1 as approved on a case basis.
2. Follow UFC 3-450-01 (Vibration and Noise Control) for acoustic design issues including speech privacy, sound isolation or sound masking.
3. Manufacturers listed below are only provided to establish a baseline of equivalency among all applicable manufacturers.

Note: Apply the below *base-wide standards* for Ceilings (products, materials and color). Then refer to the Appendix and apply any additional requirements specifically related to the Facility District in which the project is located.

E04.1.1. Exposed Framing (Roof / Floor Structure Above)

Applicable N/A

Number of base standards 1

Image Tool 250 x 188



Type: **Style 1**

Applies to: Group 1 Group 2 Group 3 Group 4 Other

Mfr: Vulcraft

Color: Neutral colors reviewed on a case basis

Finish: Field painted (Sheen per UFGS)

Model #: Formlok floor and roof decking

Other: N/A

UFGS: Section 05 30 00 Steel Decks

<http://www.wbdg.org/FFC/DOD/UFGS/UFGS 05 30 00.pdf>

E04.1.2. Exposed Concrete

Applicable N/A

E04.1.3. Grid and Acoustical Tile

Applicable N/A

Number of base standards 2

Image Tool 250 x 188



Type: **Style 1 All Purpose**

Applies to: Group 1 Group 2 Group 3 Group 4 Other

Mfr: Armstrong

Color: White

Finish: Factory

Model #: 2'x2' Tegular with reveal edge and fine texture, grid 15/16"

Other: Performance characteristics are Class A; NRC-0.70; CAC-40; LR-0.86; minimum recycled content 82%.

UFGS: Section 09 51 00 Acoustical Ceilings

<http://www.wbdg.org/FFC/DOD/UFGS/UFGS 09 51 00.pdf>

Type: **Style 2 Kitchen**

Applies to: Group 1 Group 2 Group 3 Group 4 Other

Mfr: Armstrong

Color: White

Finish: Factory

Model #: Kitchen – 2' x 2' Ceramaguard

Other: Grid 15/16" Prelude (Ceiling and grid: Fire rated when applicable)



UFGS: Section 09 51 00 Acoustical Ceilings
<http://www.wbdg.org/FFC/DOD/UFGS/UFGS 09 51 00.pdf>

E04.1.4. Gypsum Board

Applicable N/A Number of base standards 1

Image Tool 250 x 188

Type: **Style 1**

Applies to: Group 1 Group 2 Group 3 Group 4 Other

Mfr: US Gypsum

Color: Solid neutral colors

Finish: Paint (sheen per UFGS)

Model #: Tapered edge

Other: N/A

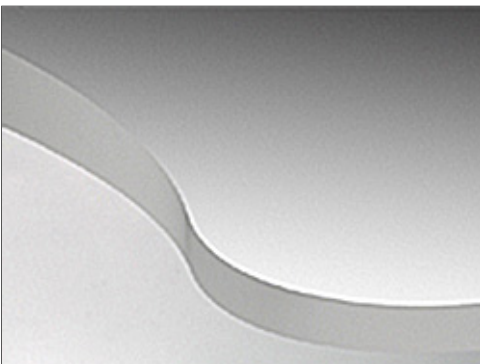

UFGS: Section 09 29 00 Gypsum Board
<http://www.wbdg.org/FFC/DOD/UFGS/UFGS 09 29 00.pdf>
Section 09 90 00 Paints and Coatings
<http://www.wbdg.org/FFC/DOD/UFGS/UFGS 09 90 00.pdf>

E04.1.5. Metal Panels

Applicable N/A

E04.1.6. Wood

Applicable N/A

E04.1.7. Rapidly-Renewable Products

Applicable N/A

E04.1.8. Other

Applicable N/A

E05. Doors and Windows

Comply with Air Force Corporate Standards for Doors and Windows:

<http://afcfs.wbdg.org/facilities-interiors/doors-and-windows/index.html>

E05.1. Doors and Windows and Frames Materials

Facility Group 1

door (frame) and window frame materials shall be as follows.

Primary: Aluminum, clear or dark bronze anodized

Secondary: Hollow metal (painted)

Tertiary: N/A

Facility Group 1

door (leaf) materials shall be as follows.

Primary: Hardwood veneer

Secondary: Hollow metal (painted)

Tertiary: N/A

Facility Group 2

door (frame) and window frame materials shall be as follows.

Primary: Aluminum, clear or dark bronze anodized

Secondary: Hollow metal (painted)

Tertiary: N/A

Facility Group 2

door (leaf) materials shall be as follows.

Primary: Hardwood veneer

Secondary: Hollow metal (painted)

Tertiary: N/A

Facility Group 3

door (frame) and window frame materials shall be as follows.

Primary: Hollow metal (galvanized, painted)

Secondary: Hollow metal (galvanized, painted)

Tertiary: N/A

Facility Group 3

door (leaf) materials shall be as follows.

Primary: Hollow metal (galvanized, painted)

Secondary: Hollow metal (galvanized, painted)

Tertiary: N/A

Facility Group 4

door (frame) and window frame materials shall be as follows.

Primary: Wood

Secondary: N/A

Tertiary: N/A

Facility Group 4

door (leaf) materials shall be as follows.

Primary: Wood solid core

Secondary: Composite solid core

Tertiary: N/A

1. Hardwood casings may be provided over metal frames in Group 1 as approved on a case basis.
2. Paneled textured doors are preferred in Group 4.
3. Do not use hollow-core wood doors.
4. Generally match original hardware in renovations.
5. Manufacturers listed below are only provided to establish a baseline of equivalency among all applicable manufacturers.

Note: Apply the below base-wide standards for Doors and Windows (products, materials and color). Then refer to the Appendix and apply any additional requirements specifically related to the Facility District in which the project is located.

E05.1.1. Aluminum

Applicable N/A

Number of base standards 1

Image Tool 250 x 188



Type: **Aluminum Doors and Frames**

Applies to: Group 1 Group 2 Group 3 Group 4 Other

Mfr: Kawneer

Color: Clear or dark bronze anodized

Finish: Factory

Model #: InFrame Interior Framing, (2x4 nominal framing)

Other: Satin stainless steel hardware

UFGS: Section 08 41 13 Aluminum-Framed Entrances and Storefronts
<http://www.wbdg.org/FFC/DOD/UFGS/UFGS 08 41 13.pdf>
 Section 08 71 00 Door Hardware
<https://www.wbdg.org/FFC/DOD/UFGS/UFGS 08 71 00.pdf>

E05.1.2. Hollow Metal

Applicable N/A

Number of base standards 2

Image Tool 250 x 188



Type: **Steel Doors**

Applies to: Group 1 Group 2 Group 3 Group 4 Other

Mfr: Steelcraft

Color: Neutral colors

Finish: Paint (Sheen per UFGS)

Model #: Hollow metal, 2" w. frames, 16 gauge (welded corners) grouted solid

Other: Provide in Group 3 and in utility areas of Group 1 and 2. Provide A25 "galvannealed" coating. All interior steel doors shall have a factory applied primer finish. Provide satin stainless steel hardware.

UFGS: Section 08 11 13 Steel Doors and Frames

<http://www.wbdg.org/FFC/DOD/UFGS/UFGS 08 11 13.pdf>

Section 08 71 00 Door Hardware

<https://www.wbdg.org/FFC/DOD/UFGS/UFGS 08 71 00.pdf>

Type: **Steel Frames**

Applies to: Group 1 Group 2 Group 3 Group 4 Other

Mfr: Steelcraft

Color: Neutral colors

Finish: Paint (Sheen per UFGS)

Model #: Hollow metal, frame grouted solid

Other: Satin stainless steel hardware

UFGS: Section 08 11 13 Steel Doors and Frames

<http://www.wbdg.org/FFC/DOD/UFGS/UFGS 08 11 13.pdf>

Section 08 71 00 Door Hardware

<https://www.wbdg.org/FFC/DOD/UFGS/UFGS 08 71 00.pdf>

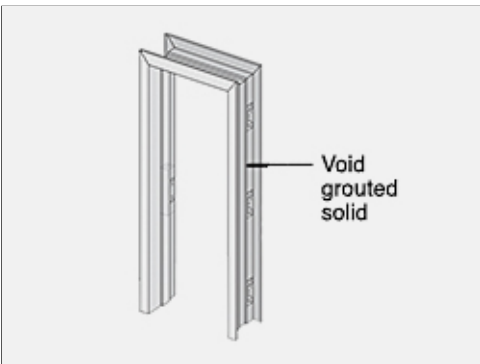

E05.1.3. Wood

Applicable N/A

Number of base standards 2

Image Tool 250 x 188



Type: **Style 1, Administrative**

Applies to: Group 1 Group 2 Group 3 Group 4 Other

Mfr: Simpson

Color: Natural hardwood veneer

Finish: Clear Sealer, satin (aqueous)

Model #: 3'x7'x 1 3/4", solid core

Other: Satin stainless steel hardware, Glass lites may be used. Stained birch veneer face, 5 ply construction, rotary cut finish.

UGFS: Section 08 14 00 Wood Doors

<http://www.wbdg.org/FFC/DOD/UGFS/UGFS 08 14 00.pdf>

Section 08 71 00 Door Hardware

<https://www.wbdg.org/FFC/DOD/UGFS/UGFS 08 71 00.pdf>

Type: **Style 2, Residential**

Applies to: Group 1 Group 2 Group 3 Group 4 Other

Mfr: Simpson

Color: Natural hardwood veneer or paint grade

Finish: Clear Sealer or paint, satin (aqueous)

Model #: Full slab or panels

Other: Satin nickel hardware

UGFS: Section 08 14 00 Wood Doors

<http://www.wbdg.org/FFC/DOD/UGFS/UGFS 08 14 00.pdf>

Section 08 71 00 Door Hardware

<https://www.wbdg.org/FFC/DOD/UGFS/UGFS 08 71 00.pdf>

E05.1.4. Other

Applicable N/A

E06. Casework Systems

E06.1. Casework Materials

1. Select casework systems and materials considering durability, maintenance requirements and LCCA.
2. Natural stone and cast stone countertops may only be used in Group 1 with approval on a case basis.
3. Metal cabinets and countertops shall be provided in heavy-use operations and in Group 3.
4. Refer to AFCFS for approved materials.
5. Manufacturers listed below are only provided to establish a baseline of equivalency among all applicable manufacturers.

E06.1.1. Plastic Laminate

Applicable N/A

Number of base standards 1

Image Tool 250 x 188



Type: **Style 1, Low Use Areas**

Applies to: Group 1 Group 2 Group 3 Group 4 Other

Mfr: Formica

Color: Medium Earth tones and neutral tones

Finish: Light textured

Model #: High pressure laminate

Other: Combine with matching solid-surface banding on casework edges.

UFGS: Section 06 41 16.00 10 Plastic-Laminate-Clad Architectural Cabinets
http://www.wbdg.org/FFC/DOD/UFGS/UFGS_06_41_16.00_10.pdf

E06.1.2. Solid Polymer Surface

Applicable N/A

Number of base standards 1

Image Tool 250 x 188



Type: **Style 1, High Use Areas**

Applies to: Group 1 Group 2 Group 3 Group 4 Other

Mfr: Corian

Color: Medium Earth tones and neutral tones

Finish: Light textured

Model #: Solid Surface

Other: Faces and edge banding

UFGS: Section 12 36 00 Countertops

[http://www.wbdg.org/FFC/DOD/UFGS/UFGS 12 36 00.pdf](http://www.wbdg.org/FFC/DOD/UFGS/UFGS_12_36_00.pdf)

E06.1.3. Rapidly-Renewable Products

Applicable N/A

Number of base standards 1

Image Tool 250 x 188



Type: **Style 1, Moderate Use Areas**

Applies to: Group 1 Group 2 Group 3 Group 4 Other

Mfr: Plyboo

Color: Natural or amber

Finish: Satin

Model #: Flat grain bamboo plywood

Other: FSC® Certified 100%.

UFGS: Section 12 32 00 Manufactured Wood Casework

[http://www.wbdg.org/FFC/DOD/UFGS/UFGS 12 32 00.pdf](http://www.wbdg.org/FFC/DOD/UFGS/UFGS_12_32_00.pdf)

E06.1.4. Metal

Applicable N/A

Number of base standards 1

Image Tool 250 x 188



Type: **Style 1**

Applies to: Group 1 Group 2 Group 3 Group 4 Other

Mfr: Steel Sentry

Color: Natural stainless steel or neural colors (steel)

Finish: Mill (stainless) or Powder coat (steel)

Model #: Lab, workbench, computer workstation

Other: Provide highly durable fabrications and finishes in Group 3 which are subjected to heavy use.

UFGS: Section 12 31 00 Manufactured Metal Casework
<http://www.wbdg.org/FFC/DOD/UFGS/UFGS 12 31 00.pdf>

E06.1.5. Other

Applicable N/A

E06.2. Countertop Materials

E06.2.1. Plastic Laminate

Applicable N/A

Number of base standards 1

Image Tool 250 x 188



Type: **Style 1, Low Use Areas**

Applies to: Group 1 Group 2 Group 3 Group 4 Other

Mfr: Formica

Color: Medium Earth tones and neutral tones

Finish: Light textured

Model #: High pressure laminate

Other: Only use rounded half or full bullnose and integral backsplash. Do not use plastic laminate edge banding on front edges.

UFGS: Section 06 41 16.00 10 Plastic-Laminate-Clad Architectural Cabinets
http://www.wbdg.org/FFC/DOD/UFGS/UFGS_06_41_16.00_10.pdf

E06.2.2. Solid Polymer Surface

Applicable N/A

Number of base standards 1

Image Tool 250 x 188



Type: **Style 1, High Use Areas**

Applies to: Group 1 Group 2 Group 3 Group 4 Other

Mfr: Corian

Color: Medium Earth tones and neutral tones

Finish: Light textured

Model #: Solid Surface

Other: Faces and edges

UFGS: Section 12 36 00 Countertops
http://www.wbdg.org/FFC/DOD/UFGS/UFGS_12_36_00.pdf

E06.2.3. Natural Stone

Applicable N/A

Number of base standards 1

Image Tool 250 x 188



Type: **Style 1, Group 1 High Visibility, Heavy Use**

Applies to: Group 1 Group 2 Group 3 Group 4 Other

Mfr: Local (TBD)

Color: Neutral tones

Finish: High polish, sealer

Model #: Custom cut slabs

Other: N/A

UFGS: Section 12 36 00 Countertops

http://www.wbdg.org/FFC/DOD/UFGS/UFGS_12_36_00.pdf

E06.2.4. Cast Stone

Applicable N/A

Number of base standards 1

Image Tool 250 x 188

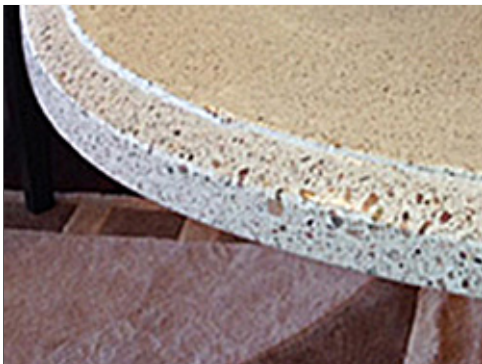

Type: **Style 1, Group 1 High Visibility, Heavy Use**

Applies to: Group 1 Group 2 Group 3 Group 4 Other

Mfr: Local (TBD)

Color: Neutral tones

Finish: High polish, sealer

Model #: Custom cast or cut slabs

Other: N/A

UFGS: Section 12 36 00 Countertops

http://www.wbdg.org/FFC/DOD/UFGS/UFGS_12_36_00.pdf

E06.2.5. Metal

Applicable N/A

Number of base standards 1

Image Tool 250 x 188



Type: **Style 1**

Applies to: Group 1 Group 2 Group 3 Group 4 Other

Mfr: Local (TBD)

Color: Natural stainless steel

Finish: Mill

Model #: Custom fabricated countertops

Other: Provide integral fronts, sides and backsplash

UGFS: Section 12 31 00 Manufactured Metal Casework
<http://www.wbdg.org/FFC/DOD/UGFS/UGFS 12 31 00.pdf>

E06.2.6. Other

Applicable N/A

E07. Furnishings

Comply with Air Force Corporate Standards for Furnishings:
<http://afcs.wbdg.org/facilities-interiors/furnishings/index.html>

E07.1. Durability and Serviceability

Comply with AF Corporate Standards for Durability and Serviceability:
<http://afcs.wbdg.org/facilities-interiors/furnishings/durability-and-serviceability/index.html>

E07.2. Accessories

Comply with AF Corporate Standards for Accessories:
<http://afcs.wbdg.org/facilities-interiors/furnishings/accessories/index.html>

E08. Interior Signs

Comply with Air Force Corporate Standards for Interior Signs:
<http://afcs.wbdg.org/facilities-interiors/interior-signs/index.html>

E08.1 Types and Color

Comply with Air Force Corporate Standards for Types and Color:
<http://afcs.wbdg.org/facilities-interiors/interior-signs/types-and-color/index.html>

E08.2. Interior Signs Materials

Natural and cast stone signs may only be used in Group 1 with approval on a case basis.

E09. Lighting, Power and Communication

<http://afcs.wbdg.org/facilities-interiors/lighting-power-and-communication/index.html>

E09.1. Functionality and Efficiency

Comply with Air Force Corporate Standards for Functionality and Efficiency:
<http://afcs.wbdg.org/facilities-interiors/lighting-power-and-communication/functionality-and-efficiency/index.html>

E09.2. Types and Color

Comply with Electrical, Lighting, Fire Protection, Telecommunication, Mechanical, and Plumbing requirements listed in Section G Appendix. Interior facility lighting fixtures shall be controlled by motion detectors and daylight controls where appropriate for energy conservation. All fixture lamps shall be LED.

F. APPENDIX - Facility Districts

- Applicable
- N/A

G. APPENDIX - References

Comply with Air Force Corporate Standards:

<http://afcfs.wbdg.org/index.html>

Comply with Nellis-Creech **Electrical** Requirements:

Copy provided by Base Civil Engineer office or Contracting Officer

Comply with Nellis-Creech **Lighting** Requirements:

Copy provided by Base Civil Engineer office or Contracting Officer

Comply with Nellis-Creech **Fire Protection** Requirements:

Copy provided by Base Civil Engineer office or Contracting Officer

Comply with Nellis-Creech **Mechanical-Plumbing** Requirements:

Copy provided by Base Civil Engineer office or Contracting Officer

Comply with Nellis-Creech **Utility Meter** Requirements:

Copy provided by Base Civil Engineer office or Contracting Officer

Comply with Nellis-Creech **Telecommunications** Requirements:

Copy provided by Base Civil Engineer office or Contracting Officer