

LAJES FIELD INSTALLATION FACILITIES STANDARDS (IFS)



Installation Elements



Site Development



Facilities Exteriors

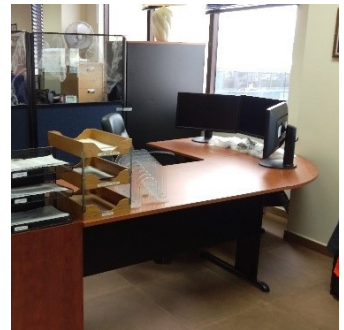

Facilities Interiors

APPROVED FOR PUBLIC RELEASE; DISTRIBUTION UNLIMITED

Lajes Field IFS

Table of Contents

A. OVERVIEW	5	B03.2.3. Preserves	
A01. Facility Hierarchy	6	B03.2.4. Perimeter Fence	
A02. Facility Quality	6	C. SITE DEVELOPMENT	32
A03. Facility Districts	6	C01. Site Design	32
B. INSTALLATION ELEMENTS	8	C01.1. Site Design Considerations	32
B01. Comprehensive Planning	8	C01.2. Building Orientation	34
B01.1. Installation Development Plan (IDP)	8	C02. Utilities	35
B01.1.1. IFS Component Plan of IDP		C02.1. Utility Components.....	35
B01.1.2. Brief History of Base		C03. Parking Areas	37
B01.1.3. Future Development		C03.1. Configurations and Design	38
B02. Street Envelope Standards	13	C03.1.1. Paving and Striping	
B02.1. Hierarchy of Streets	13	C03.1.2. Curbing	
B02.1.1. Arterial Streets		C03.1.3. Internal Islands and Medians	
B02.1.2. Collector Streets		C03.2. Parking Structures	41
B02.1.3. Local Streets		C03.3. Connectivity	42
B02.1.4. Special Routes		C04. Stormwater Management	42
B02.2. Hierarchy of Intersections	17	C04.1. Stormwater Requirements	42
B02.2.1. Arterials		C05. Sidewalks, Bikeways and Trails	43
B02.2.2. Arterial/Collector		C05.1. Circulation and Paving	43
B02.2.3. Collectors		C05.1.1. Ramps and Stairs	
B02.2.4. Special Intersections		C05.1.2. Lighting	
B02.2.5. Street Frontage Requirements		C06. Landscape	45
B02.2.6. Sight Lines		C06.1. Climate-based Materials	46
B02.3. Street Elements	19	C06.1.1. Landscape Design Concept	
B02.3.1. Paving		C06.1.2. Xeriscape Design Principles	
B02.3.2. Curb and Gutter		C06.1.3. Minimizing Water Requirements	
B02.3.3. Utility Service Elements		C06.1.4. Plant Material Selection	
B02.3.4. Traffic Signs		C06.1.5. Water Budgeting (Hydrozones)	
B02.3.5. Street Lighting		C06.1.6. Base Entrance Landscaping	
B02.3.6. Other		C06.1.7. Streetscape Landscaping	
B03. Open Space / Public Space	24	C06.1.8. Pedestrian Circulation Landscaping	
B03.1. Plazas, Monuments and Static Displays	24	C06.1.9. Parking Lot Landscaping	
B03.1.1. Paved Plazas		C06.1.10. Screen/Accent Landscaping	
B03.1.2. Sculptures, Markers and Statuary		C06.1.11. Other	
B03.1.3. Static Display of Aircraft		C07. Site Furnishings	53
B03.2. Grounds and Perimeters	28	C07.1. Furnishings and Elements	53
B03.2.1. Parade Grounds			
B03.2.2. Parks			

Table of contents continued

C07.2. Site Furnishings Products, Materials / Color ..	55	D03.3.4. Thermal Shading	
C07.2.1. Barbeque Grills		D03.3.5. Renewable Heating/Cooling	
C07.2.2. Benches		D03.3.6. Solar Photovoltaic System	
C07.2.3. Bike Racks		D03.3.7. Solar Thermal System	
C07.2.4. Bike Lockers		D04. Building Entrances	107
C07.2.5. Bollards		D04.1. Primary Entrances	108
C07.2.6. Bus Shelters		D04.2. Secondary Entrances	108
C07.2.7. Drinking Fountains		D05. Wall Systems	109
C07.2.8. Dumpster Enclosures / Gates		D05.1. Hierarchy of Materials	110
C07.2.9. Fencing		D05.2. Layout, Organization and Durability	110
C07.2.10. Flagpoles		D05.3. Equipment, Vents and Devices	111
C07.2.11. Lighting – Landscape / Accent		D05.4 Wall Systems Materials	111
C07.2.12. Litter and Ash Receptacles		D05.4.1. Flat Metal Panels	
C07.2.13. Picnic Tables		D05.4.2. Brick Veneer	
C07.2.14. Planters – Free Standing		D05.4.3. Architectural Precast	
C07.2.15. Play Equipment		D05.4.4. Stucco Over Sheathing	
C07.2.16. Screen Walls		D05.4.5. Curtain Wall	
C07.2.17. Tree Grates		D05.4.6. Cast-in Place Concrete	
C07.2.18. Other		D05.4.7. Tilt-up Concrete	
C08. Exterior Signs	76	D05.4.8. Ribbed Metal Sheeting	
C08.1. Colors and Types	76	D05.4.9. EIFS	
C08.1.1. Materials and Color Specifications		D05.4.10.GFRC	
C08.1.2. Installation and Gate Identification Signs		D05.4.11.Concrete Block	
C08.1.3. Building Identification Signs		D05.4.12. Fiber Cement Siding	
C08.1.4. Traffic Control Devices (Street Signs)		D05.4.13. Other	
C08.1.5. Directional and Wayfinding Signs		D06. Doors and Windows	115
C08.1.6. Informational Signs		D06.1. Types	116
C08.1.7. Motivational Signs		D06.2. Layout and Geometry	116
C08.1.8. Parking Lot Signs		D06.3. Glazing and Shading	116
C08.1.9. Regulatory Signs		D06.4. Hardware	116
C08.1.10. Other		D06.5. Doors and Windows Materials	117
C09. Lighting	92	D06.5.1. Anodized Aluminum	
C09.1. Fixtures and Lamping	93	D06.5.2. Hollow Metal	
C09.2. Light Fixture Types	94	D06.5.3. Aluminum-clad Wood	
C09.2.1. Street Lighting		D06.5.4. Other	
C09.2.2. Parking Lot Lighting		D07. Roof Systems	119
C09.2.3. Lighted Bollards		D07.1. Roof Type and Form	120
C09.2.4. Sidewalk Lighting		D07.2. Roof Slope	120
C09.2.5. Walls / Stairs Lighting		D07.3. Parapets and Copings	121
C09.2.6. Other		D07.4. Color and Reflectivity	121
D. FACILITIES EXTERIORS	99	D07.5. Gutters, Downspouts, Scuppers, Drains	121
D01. Supporting the Mission	99	D07.6. Roof Vents and Elements	121
D02. Sustainability	99	D07.7. Clerestories and Skylights	122
D03. Architectural Features	100	D07.8. Vegetated Roof	122
D03.1. Orientation, Massing and Scale	101		
D03.2. Architectural Character	101		
D03.3. Details and Color	101		
D03.3.1. Climate-based Data			
D03.3.2. Natural Ventilation System			
D03.3.3. Thermal Mass			

Table of contents continued

D07.9. Roof Systems Materials	122	E04. Ceilings	150
D07.9.1. Standing Seam Metal		E04.1. Ceiling Materials	150
D07.9.2. Membrane Single-ply		E04.1.1. Exposed Framing (Roof / Floor Structure	
D07.9.3. Built-up Multi-ply		Above)	
D07.9.4. Concrete Tile		E04.1.2. Exposed Concrete	
D07.9.5. Clay Tile		E04.1.3. Grid and Acoustical Tile	
D07.9.6. Slate Shingles		E04.1.4. Gypsum Board	
D07.9.7. Vegetated System		E04.1.5. Metal Panels	
D07.9.8. Ribbed Metal Sheeting		E04.1.6. Wood	
D07.9.9. Composite Shingles		E04.1.7. Rapidly-Renewable Products	
D07.9.10. Other		E04.1.8. Other	
D08. Structural Systems	126	E05. Doors and Windows	153
D08.1. Systems and Layouts	127	E05.1. Doors and Windows and Frames Materials	153
D08.2. Structural Systems Materials	127	E05.1.1. Aluminum	
D08.2.1. Concrete		E05.1.2. Hollow Metal	
D08.2.2. Insulated Concrete Forming (ICF)		E05.1.3. Wood	
D08.2.3. Steel		E05.1.4. Other	
D08.2.4. Pre-Engineered Steel		E06. Casework Systems	157
D08.2.5. Masonry		E06.1. Casework Materials	157
D08.2.6. Heavy Timber		E06.1.1. Plastic Laminate	
D08.2.7. Light-gauge Steel		E06.1.2. Solid Polymer Surface	
D08.2.8. Lumber Framing		E06.1.3. Rapidly-Renewable Products	
D08.2.9. Other		E06.1.4. Metal	
D09. Mechanical, Electrical and Plumbing	130	E06.1.5 Other	
D09.1. Passive and Active Systems	131	E06.2. Countertop Materials	160
D09.2. Functionality and Efficiency	131	E06.2.1. Plastic Laminate	
E. FACILITIES INTERIORS	132	E06.2.2. Solid Polymer Surface	
E01. Building Configurations	133	E06.2.3. Natural Stone	
E01.1. Layout and Common Areas	133	E06.2.4. Cast Stone	
E01.1.1. Interior Design Process		E06.2.5. Metal	
E01.1.2. Codes and Regulations		E06.2.6 Other	
E01.2. Quality and Comfort	135	E07. Furnishings	162
E02. Floors	135	E07.1. Durability and Serviceability	162
E02.1. Floor Materials	135	E07.2. Accessories	162
E02.1.1. Prepared Slabs		E08. Interior Signs	162
E02.1.2. Natural Stone and Terrazzo		E08.1 Types and Color	162
E02.1.3. Quarry Tile		E08.2. Interior Signs Materials	163
E02.1.4. Ceramic Tile		E09. Lighting, Power and Communication	163
E02.1.5. Resilient Floor		E09.1. Functionality and Efficiency	163
E02.1.6. Carpet		E09.2. Types and Color	163
E02.1.7. Rapidly-Renewable Products		F. Appendices	164
E02.1.8. Other		G. Appendices	164
E03. Walls	143		
E03.1. Wall Materials	143		
E03.1.1. Concrete			
E03.1.2. Masonry			
E03.1.3. Ceramic Tile			
E03.1.4. Gypsum Board			
E03.1.5. Metal Panels			
E03.1.6. Wood Paneling			
E03.1.7. Rapidly-Renewable Products			
E03.1.8. Other			

A. OVERVIEW

Comply with Air Force Corporate Standards for Overview:

<http://afcfs.wbdg.org/index.html>

This Installation Facilities Standards (IFS) document is part of the Air Force Corporate Facilities Standards (AFCFS) program to assist bases in implementing and maintaining facilities standards as appropriate for efficient operations within the respective climate region. IFS fully replaces, consolidates and simplifies existing facilities standards documents, such as the Architectural Compatibility Plan (ACP) or ACGs, FEPs, etc., and organizes information using the same structure, or Table of Contents, as the AFCFS website.

IFS reflects the AFCFS' concepts of "Facility Hierarchy" (categorizing facilities into group numbers) and "Facility Quality" (assigning an appropriate level of quality to each group number) and applies these principles at the base level. Applicable DoD and Air Force criteria such as UFCs, AFIs, Memoranda, and UFGSs (Guide Specs) are referenced and linked within IFS to ensure the document is always current.

Navigating within this IFS is efficient and straightforward. Please use the interactive Table of Contents to locate subject matter, and click on the title of a section to access it. From any page, click on the "Back to Table of Contents" footer to return. Content is organized into 4 major sections: Installation Elements, Site Development, Facilities Exteriors and Facilities Interiors.

This IFS document begins as a fill-in PDF form, which is fully editable, and becomes a "living document" that can be regularly updated by base-level personnel following a format that is consistent across the Air Force. While the format is standardized, IFS content is customized for base operations and the local climate to ensure mission success while emphasizing reduced maintenance and reduced initial costs, life-cycle costs, energy use, and water use.

1. Conformance to Air Force Corporate Facilities Standards (AFCFS) and Installation Facilities Standards (IFS) are required by Air Force Instruction (AFI) 32-1023 and Air Force Memorandum. Please refer to the AFCFS website for links to documentation on current policy.
2. Requests to deviate from any installation facilities standards, that are Unified Facilities Criteria (UFC) requirements, will follow the process outlined in the AFCFS for UFC waivers and exemptions.
3. The IFS is a component plan of the Installation Development Plan (IDP) per Air Force Instruction (AFI) 32-7062 (replacing the Architectural Compatibility Plan). All military construction projects and Non-Appropriated Funds (NAF) facilities are required to comply with the IDP and its IFS component plan by AFI 32-1023. The Base Civil Engineer (BCE) maintains and implements the IDP and its component plans, to include the IFS.
4. Please refer to the AFCFS website as a portal to reference materials and requirements documents for design and construction projects (via links). Specific references to current DoD memoranda and Air Force criteria are updated periodically to provide the most current guidance and requirements. Programming, design and contract documents should list "current edition" for all reference and requirements documents. The documents in force at the date of execution of the design and/or construction contract shall be the governing version.
5. *Advanced Modeling Requirements:*
For all Air Force projects requiring advanced modeling, to include 3D visualization, Building Information Modeling (BIM), facility data, quantity take-off, geospatial, etc., follow the Army standards. Refer to USACE Minimum Model Matrix (M3) and Project Execution Plan (PxP) which outline required model uses. Refer to [CAD BIM Technology Center \(Contract Requirements\)](#) for more information on M3 and PxP.
6. Joint Bases shall implement IFS under their Joint-Base designation with volume numbers for individual installations following the IFS Development Tool template. For example, for Joint Base Langley-Eustis, provide: Vol. 1 Langley AFB and Vol. 2 Fort Eustis.
7. References and Supplementary Documents listed in Appendix G are included in these Installation Facilities Standards by reference and are fully part of this document. Please refer to [Appendix G](#) for a listing of documents, which are available via hyperlink for viewing and downloading.
8. Installations outside the United States: Per UFC 1-200-01 DOD BUILDING CODE, 8 Oct 2019, "All construction outside of the United States is also governed by Status of Forces Agreements (SOFA), Host Nation Funded Construction Agreements (HNFA), and in some instances, Bilateral Infrastructure Agreements (BIA). Therefore, the acquisition team must ensure compliance with the most stringent of the UFC, the SOFA, the HNFA, and the BIA, as applicable." Refer to [Appendix G](#) for applicable agreements. "Use UFC 1-202-01 for design of host nation facilities that support military operations."
<https://www.wbdg.org/ffc/dod/unified-facilities-criteria-ufc/ufc-1-202-01>

Applicable N/A Select number of graphics / images (large: 800 px x 440 px) to insert 1

Image Tool 800 x 440

Applicable N/A Select number of graphics / images (small: 250 px x 188 px) to insert 3

Image Tool 250 x 188

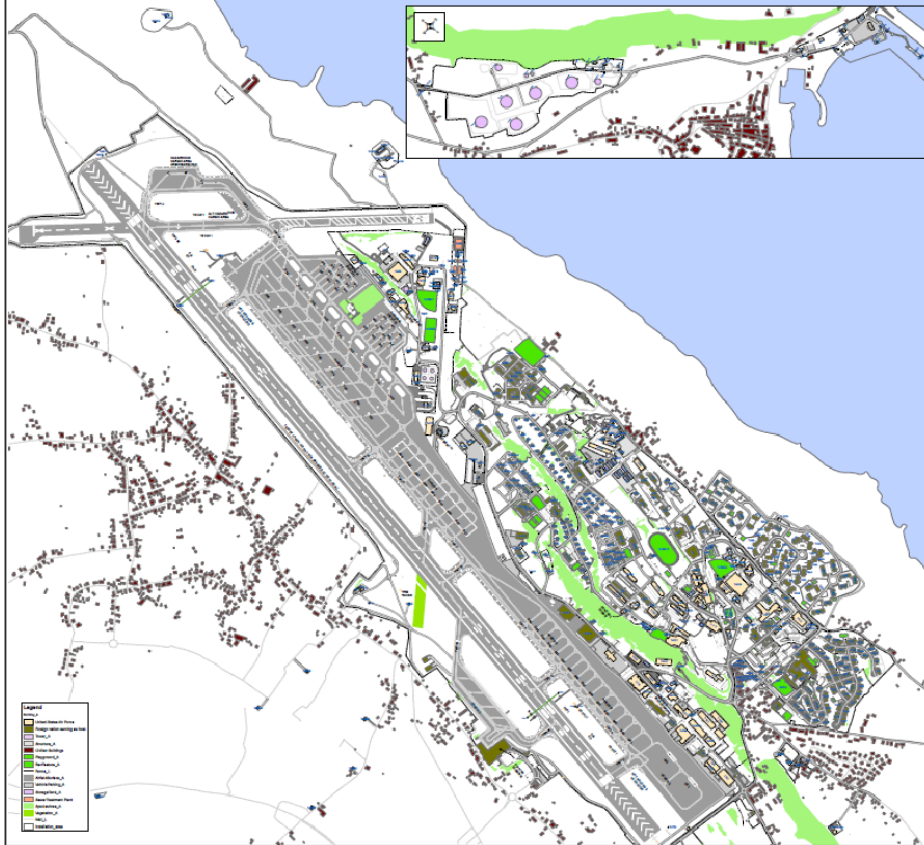

Refer to Base Comprehensive Plan (BCP) - Lajes Field



Refer to BCP for Plan of Vila Nova



Refer to BCP for Plan of Serra do Cume

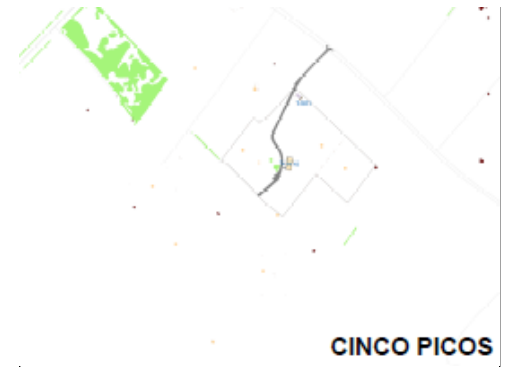

Refer to BCP for Plan of Cinco Picos

A01. FACILITY HIERARCHY

Comply with AF Corporate Standards for Facility Hierarchy (and subsections):

<http://afcs.wbdg.org/facility-hierarchy/index.html>

A02. FACILITY QUALITY

Comply with AF Corporate Standards for Facility Quality (and subsections):

<http://afcs.wbdg.org/facility-quality/index.html>

A03. FACILITY DISTRICTS

Comply with AF Corporate Standards for Facility Districts (and subsections):

<http://afcs.wbdg.org/facility-districts/index.html>

Image Tool 800 x 800

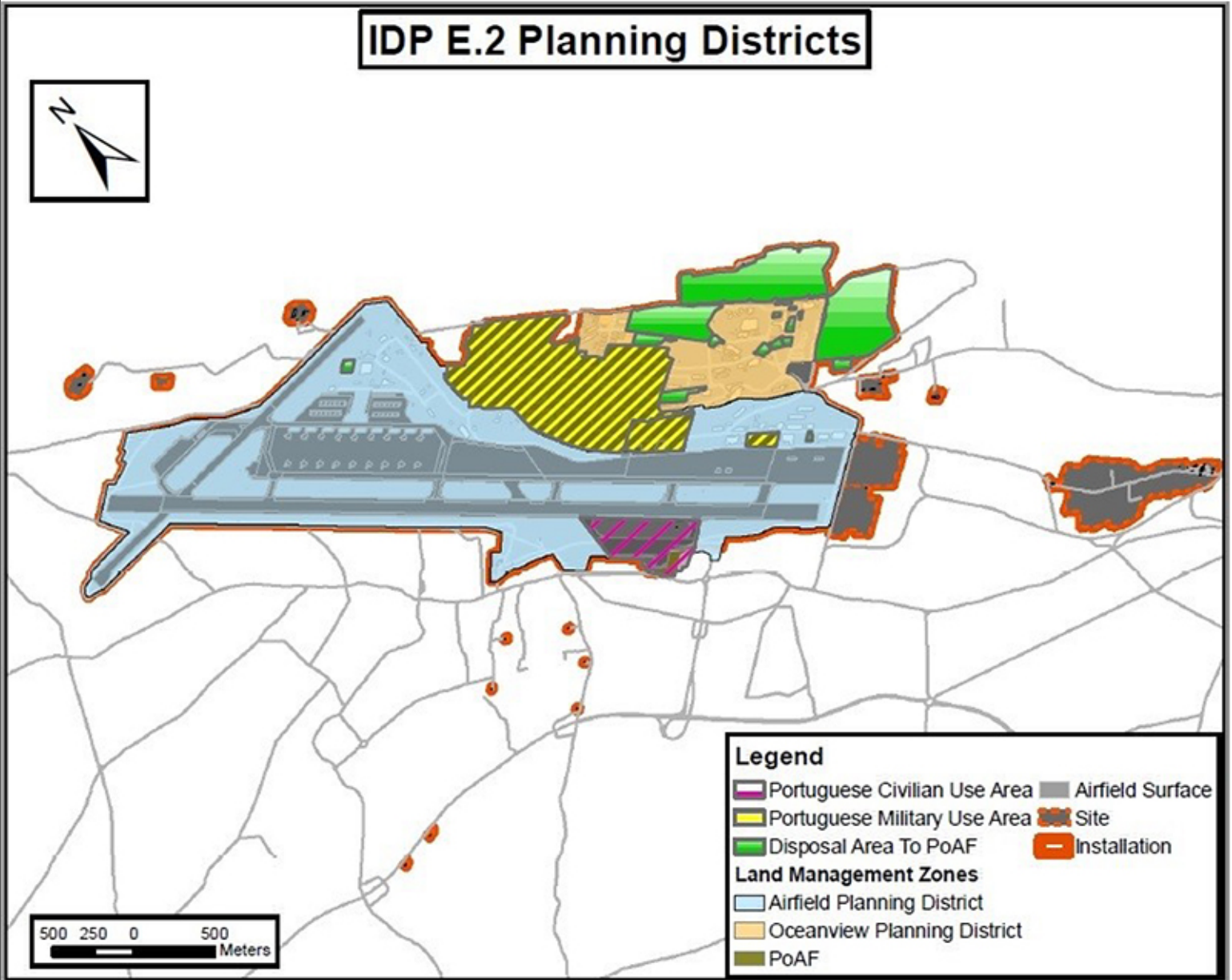

Note: Apply the base-wide standards in this IFS for Installation Elements, Site Development, Facilities Exteriors and Facilities Interiors (products, materials, color, etc.). Following application of the base-wide standards, refer to the Appendix and apply any additional requirements specifically related to the Facility District.

B. INSTALLATION ELEMENTS

Comply with Air Force Corporate Standards for Installation Elements:

<http://afcs.wbdg.org/installation-elements/index.html>

B01. COMPREHENSIVE PLANNING

Comply with Air Force Corporate Standards for Comprehensive Planning:

<http://afcs.wbdg.org/installation-elements/comprehensive-planning/index.html>

B01.1. Installation Development Plan (IDP)

Applicable N/A Select number of graphics / images (large: 800 px x 440 px) to insert 1

Image Tool 800 x 440

Applicable N/A Small graphics do not apply

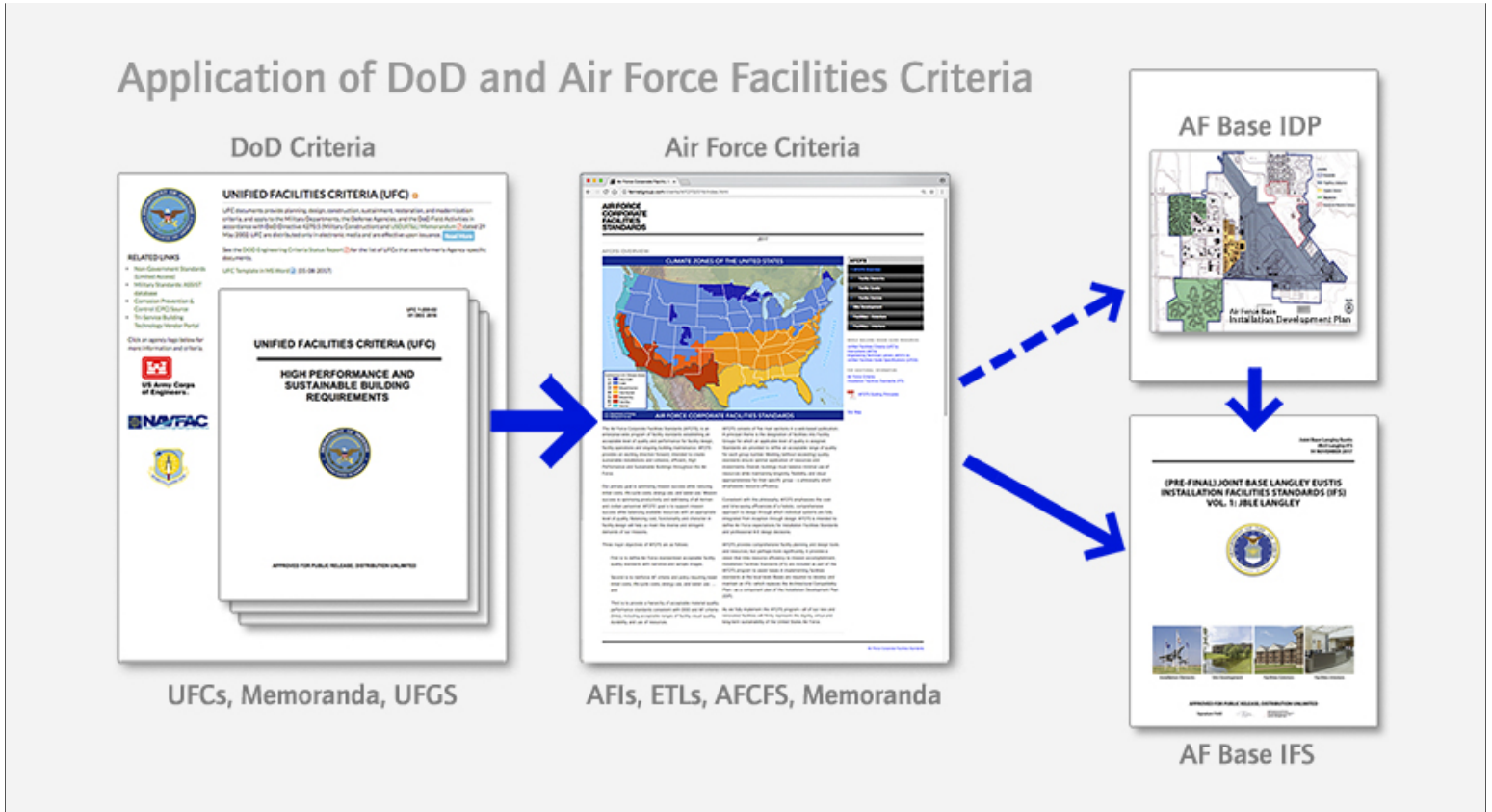

Department of Defense, Department of the Air Force and Air Force Base Criteria

1. The Base Civil Engineer is responsible for developing, maintaining and implementing the installation's Master Planning documents and to ensure that the Installation Development Plan (IDP) is prepared, maintained, and implemented following AFI 32-7062.
2. Refer to the IDP for information on climate and weather and for demographics and related data.

B01.1.1. IFS Component Plan of IDP

Applicable N/A Select number of graphics / images (large: 800 px x 440 px) to insert 1

Image Tool 800 x 440

Applicable N/A Select number of graphics / images (small: 250 px x 188 px) to insert 3

Image Tool 250 x 188



Base Development



Partial Aerial View of the Main Base



Clear Site Lines and Pedestrian Access



T-100 Aerial View

1. Maintain this Installation Facilities Standards (IFS) as a Component Plan of the base's Installation Development Plan (IDP).

B01.1.2. Brief History of Base

Applicable N/A Select number of graphics / images (large: 800 px x 440 px) to insert 1

Image Tool 800 x 440

Applicable N/A Select number of graphics / images (small: 250 px x 188 px) to insert 3

Image Tool 250 x 188



Lajes Field in 1955



Welcome Sign



Historic Image of the Main Gate



Historic Image of the Aircraft and Crew

Lajes Field (LF) is located at Portuguese Air Base No. 4 (AB4), where the 65th Air Base Group (65 ABG) is stationed as the American Detachment for this installation by agreement with the Republic of Portugal. It is a Portuguese owned and hosted base. In 1953, the U.S. Forces Azores Command was organized as a subordinate Unified Command under the Commander-in-Chief, U.S. Atlantic.

In February 1953, the 1605th Air Base Wing of the Military Airlift Command was established and on 1 January 1982, it was changed to 1605th Military Airlift Support Wing. In January 1992, the 1605th Military Airlift Support Wing was re-designated as the 606th Military Airlift Support Wing. On 1 June 1992, the Wing was re-designated as the 65th Support Wing. In July 1993, it was re-designated again as the 65th Air Base Wing. Due to force restructuring in 2002, LF was reassigned from Air Combat

Command (ACC) to United States Air Forces Europe (USAFE). On 14 August 2015, the base was designated as the 65th Air Base Group and reassigned to the 86th Airlift Wing.

The Group Commander is the local representative for the U.S. Ambassador to the Portuguese military and civil authorities concerning all military activities in the Azores.

The current mission for AB4 is search and rescue and base defense. Merlin helicopters are used to carry out search and rescue missions along with other Portuguese aircraft utilized for air transport and medical evacuations within the archipelago. Terceira Island is one of 9 volcanic islands of the Azores. The island is located about 3,500 km (2,220 miles) east of New York City and 1,370 km (850 miles) west of Portugal. The island is approximately 19 km (12 miles) north to south and 32 km (20 miles) east to west. Lajes Field is on the northeast edge of the island. The Azores have a population of 242,846, with about 55,234 living on Terceira (Nomenclatura das Unidades Territoriais para Fins Estatísticos, 2013). There are two counties on the island, Angra do Heroísmo, with around 33,903 residents and Praia da Vitória, with about 21,331 residents.

LF occupies approximately 1.52 square miles (973 acres) of the island in addition to 13 off base sites for navigational aids, communication aids, water wells, ammunition and fuel storage, which combined total an additional 0.74 square miles (472 acres). Portuguese seafarers, under the direction of Henry the Navigator, discovered the Azores Islands in 1432. Colonization of the islands began in 1452, led by Gonçalo Velho Cabral, a Portuguese nobleman. The Azores quickly became important as a port of call for sailing ships crossing the Atlantic between the New World, Africa and Europe, as well as those returning to Europe from India.

The islands also became the scene of battles between merchant ships and French, Moorish and English pirates. Christopher Columbus is reported to have stopped at Santa Maria on one of his voyages of discovery to North America. Terceira islanders are proud of their role in the discovery of the "New World." Gaspar Corte Real, a native of Terceira, discovered Newfoundland. His brother, Miguel, may have visited North America before Columbus. Labrador, a farmer from Terceira, is said to have discovered the land that bears his name.

By the 16th century, Terceira, the "Gibraltar of the Atlantic," was a base of power by which Portugal protected her lines of defense and colonies when Philip II of Spain successfully claimed the vacant throne. Terceira refused to accept Spanish rule and became the center of Portuguese resistance for two years.

Spain's first attempt to crush Portuguese independence resulted in a humiliating defeat for what was then Europe's strongest military power. The Spanish attempted an amphibious landing by sending 2,000 men. The outnumbered defenders waited for the heavily armed attackers to reach the shore, then drove a large herd of wild bulls onto the beach. Nearly 1,500 of the invaders reportedly drowned as they struggled to return to their ships. As a tribute to the islander's resistance, the capital of Terceira was later named Angra do Heroísmo, which translates to English as "Bay of Heroism."

One of the most important historic buildings in the Azores is the Citadel of St. John the Baptist, located on the isthmus of Monte Brasil, overlooking Angra. Philip II began construction of the formidable fortress in 1590, after resistance in the Azores was subdued. However, Portugal regained its independence from Spain in 1640 and soon thereafter, King John IV ordered a church built within the fortress. It was to be called the Church of St. John the Baptist, from which the Citadel acquired its present name.

A Portuguese army battalion stationed on Terceira still uses portions of the fortress. In the 18th and 19th centuries, the Azores Islands held a prominent place in the whaling industry of the Atlantic. Many Azoreans signed on as crewman for American whaling ships. Some later immigrated to the United States and founded Portuguese communities in California and New England. With the development of aviation, the Azores became an important element in transatlantic air travel. This was first demonstrated in 1919 when A.C. Red, a U.S. Navy Commander, made a refueling stop at Faial during the first crossing of the Atlantic Ocean by air. The British and after the United States, used the islands as a mid-Atlantic refueling stop in World War II, both for cargo aircraft and for combat aircraft being ferried to both Africa and Europe.

In 1945, the joint forces on Terceira were handling 3,000 aircraft per month, as they became known as the "Atlantic Crossroads" and "Grand Central Station" of the Atlantic. In 1946, as the British left Terceira, the Portuguese government asked the U.S. to move its forces to Terceira.

In 1952, the U.S. Army transferred a transportation unit to the base. In 1953, the U.S. Air Force established an air wing and in 1957, the U.S. Navy joined the forces. NATO called on LF to support Operations DESERT SHIELD, DESERT STORM, RESTORE HOPE, ENDURING FREEDOM and IRAQI FREEDOM. LF on Terceira is now the center of military aviation in the Azores. The airport at Sao Miguel handles much of the international commercial aviation traffic.

Dairy farming is the primary industry on Terceira. While crop farming has decreased recently, growing tobacco, corn, clover, wheat, beans, tea, grapes, chicory, bananas and pineapples are the main crops. Fishing is still an active industry for the Azores. Azoreans are known for their craftsmanship in weaving, embroidery and production of tools, utensils and farm implements. While the Azores operate as a regional autonomy, they also fall under the sovereignty of the Portuguese Republic. The Regional Government consists of a president, Vice-president and nine functional secretaries who perform public administration and develop economic proposals.

The National Government is responsible for defense, fiscal policy and foreign affairs. A Minister of the Republic performs coordination between the national and regional government, chosen by the Portuguese Prime Minister and appointed by the President of the Republic.

The U.S. presence is a well-accepted and integral part of the community. Most Americans stationed at LF live off base. There is a policy that U.S. personnel rotate every 12 to 24 months on average, this detracts from long-term, consistent knowledge by Americans of the design and construction criteria or background on base.

B01.1.3. Future Development

Applicable N/A Select number of graphics / images (large: 800 px x 440 px) to insert 1

Image Tool 800 x 440

Applicable N/A Small graphics do not apply



Base Comprehensive Plan - Future Land Use

1. Follow AFI 32-7062 for Air Force Comprehensive Planning, the Comprehensive Planning Process, Comprehensive Planning Requirements, and Geospatial Mapping.
2. Address all future development under the Installation Development Plan (IDP).
3. Accommodate planned reduction in mission, personnel and installation footprint due to European Infrastructure Consolidation (EIC) with acceptable building maintenance or replacement.

- Implement IDP requirements for the transportation system including vehicular circulation, parking, traffic control, pedestrian systems, and entry gate operations following this IFS.

B02. STREET ENVELOPE STANDARDS

Comply with Air Force Corporate Standards for Installation Elements:

<http://afcf.wbdg.org/installation-elements/index.html>

Comply with AF Corporate Standards for Street Envelope Standards:

<http://afcf.wbdg.org/installation-elements/street-envelope-standards/index.html>

B02.1. Hierarchy of Streets

Applicable N/A Large graphics do not apply

Applicable N/A Select number of graphics / images (small: 250 px x 188 px) to insert 3

Image Tool 250 x 188

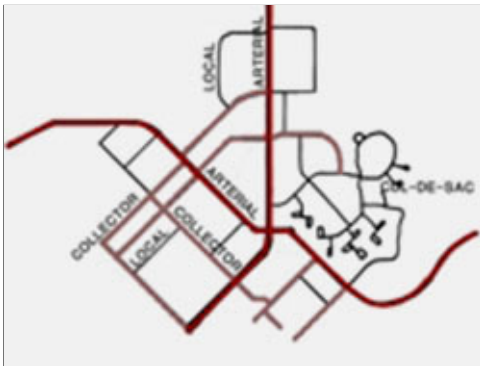

Hierarchy of Streets

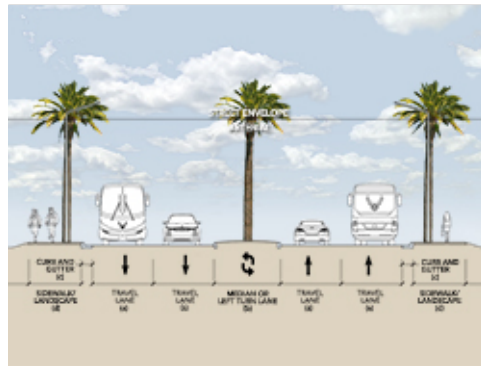

Street Envelope Section



Clear Visibility at Intersection

- Develop and evolve a hierarchical transportation network of arterial, collector and local streets following UFC 3-201-01 and its industry references.
- Provide consistent functionality throughout the installation and a level of visual quality relating to the adjacent Facility Group number.
- Routes along facilities in Group 1 may have materials, finishes and features with a higher visual quality than Groups 2, 3 and 4. Reduce maintenance requirements by installing highly durable materials and finishes in routes along Group 3 industrial facilities.
- Special routes may have a visual quality comparable to those along facilities in Group 1.
- Create and maintain arterials with two lanes of traffic in each direction with landscaped or paved medians as applicable to the local climate and adjacent facility group designation / land use.
- Minimize stops and turns along arterials. Eliminate on-street parking along arterials and provide on collector streets only on lower speed roadways such as residential streets.
- Connect arterials to local streets with appropriately scaled collector streets.
- Provide appropriate landscape setbacks and pedestrian buffers along all streets.
- Minimize and consolidate curb cuts along streets.
- Ensure access for emergency and service vehicles.
- Define bicycle traffic routes in the Installation Development Plan or its applicable component plans.

12. Define appropriate force protection features, site furnishings, signs, lighting, utilities, and paving in the IFS.

13. Pavement markings must be according to European Union (EU) standards.

14. See Appendix G for additional information.

B02.1.1. Arterial Streets

Applicable N/A Select number of graphics / images (large: 800 px x 440 px) to insert 1

Image Tool 800 x 440

Applicable N/A Select number of graphics / images (small: 250 px x 188 px) to insert 1

Image Tool 250 x 188

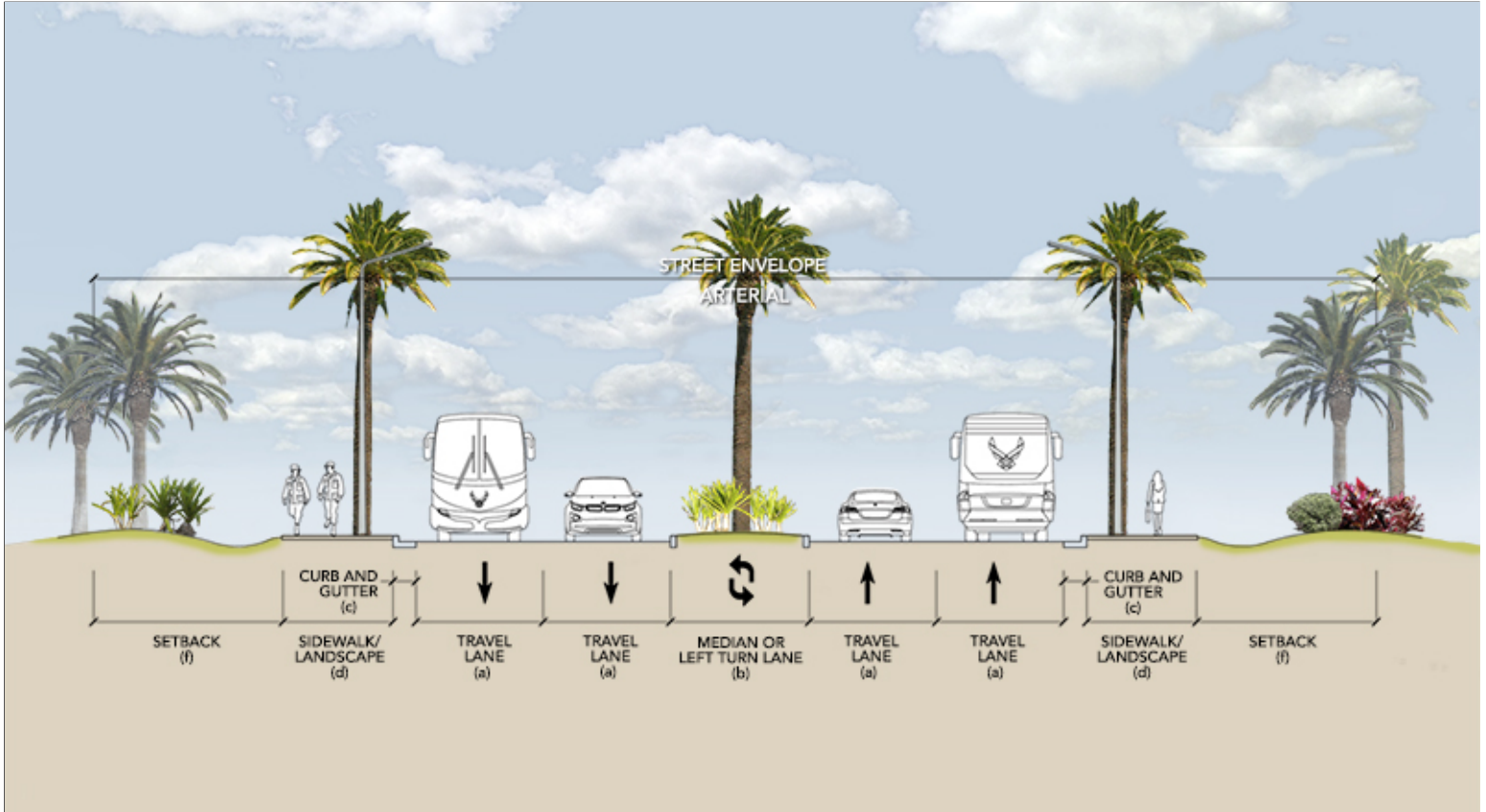

Travel Lane (a): 12' Median (b): 12' Curb and Gutter (c): 2' Sidewalk / Landscape (d): 12' Setback (f): Min. 35' or per ATFP

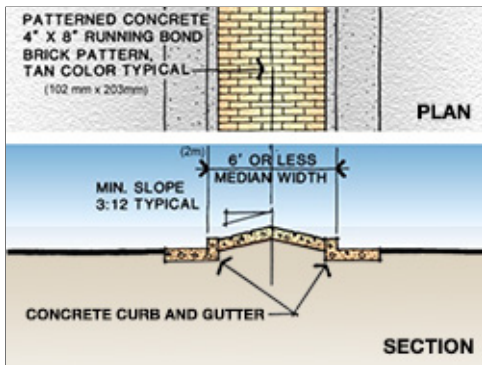

Paved Median

1. Arterial Streets include Avenida do Imperio, Rua de 25 Abril and Rua Portugal.

2. Stops and turns should be minimized and on-street parking shall not be allowed at any point along arterial streets.

3. Provide sidewalks on at least one side of arterial streets and both sides of arterial streets in developed areas. Provide a 6' buffer between the road and sidewalk where space allows.
4. Limit curb cuts on arterial streets to entries into major facilities, building groups and major parking areas.
5. Reinforce the importance of arterial streets with appropriate signs, plantings and street lighting.
6. Major intersections shall be identified visually with low plantings and ornamental trees.
7. Large trees shall be planted along both sides to create a canopy, screen views, impose order and create interest.
8. Accommodate pedestrian rest stops or waysides at a maximum distance of 180 meters (600 feet).
9. Pedestrian crosswalks shall be clearly defined at each intersection with solid white markings, contrasting pavers or raised crosswalks/speed humps.

B02.1.2. Collector Streets

Applicable N/A Select number of graphics / images (large: 800 px x 440 px) to insert 1

Image Tool 800 x 440

Applicable N/A Small graphics do not apply

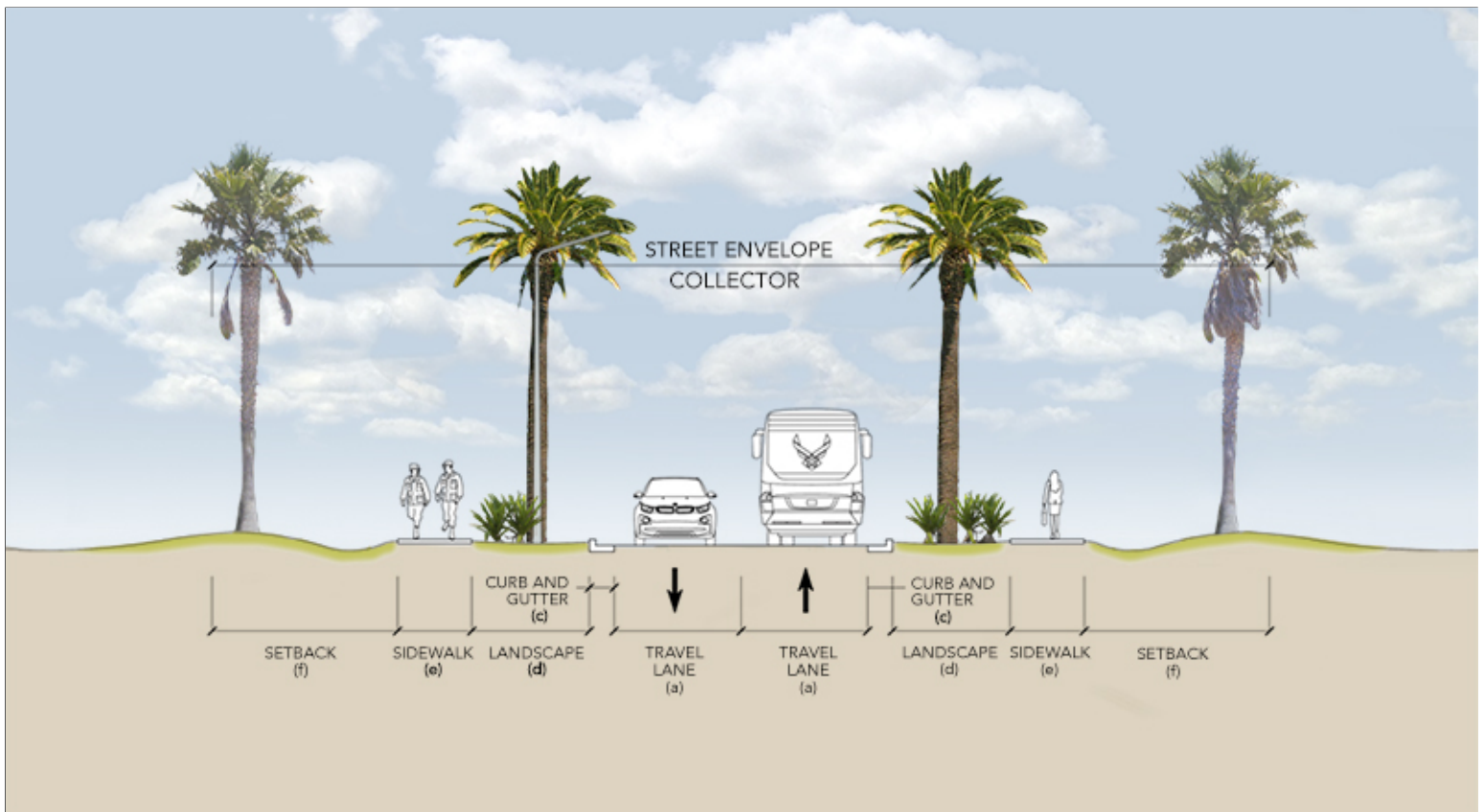

Travel Lane (a): 12' Median (b): N/A Curb and Gutter (c): 2' Landscape (d): 10' Sidewalk (e): 6' Setback (f): Min. 35' or per ATFP

1. Collector Streets include Rua Acores, Rua do Sol, Rua do Hospital, Rua Atlantico, Rua do Cinema and Rua Velha.
2. Frequent traffic stops and low speeds are permitted on collector streets.
3. Provide sidewalks on at least one side of collector streets and both sides of collector streets where functionally required. Buffers are preferred but not required on collector streets.

4. On-street parking may be allowed on one side where secondary roads are not less than 34 feet wide. Parking shall not interfere with intersections or traffic flow.
5. Signs, plantings and street lighting should reinforce the designation of “collector” street.
6. Where above ground utilities exist, use street trees, a stone wall, or fence as a screen. Street trees used in this manner should not physically interfere with utilities.

B02.1.3. Local Streets

Applicable N/A Select number of graphics / images (large: 800 px x 440 px) to insert 1

Image Tool 800 x 440

Applicable N/A Small graphics do not apply

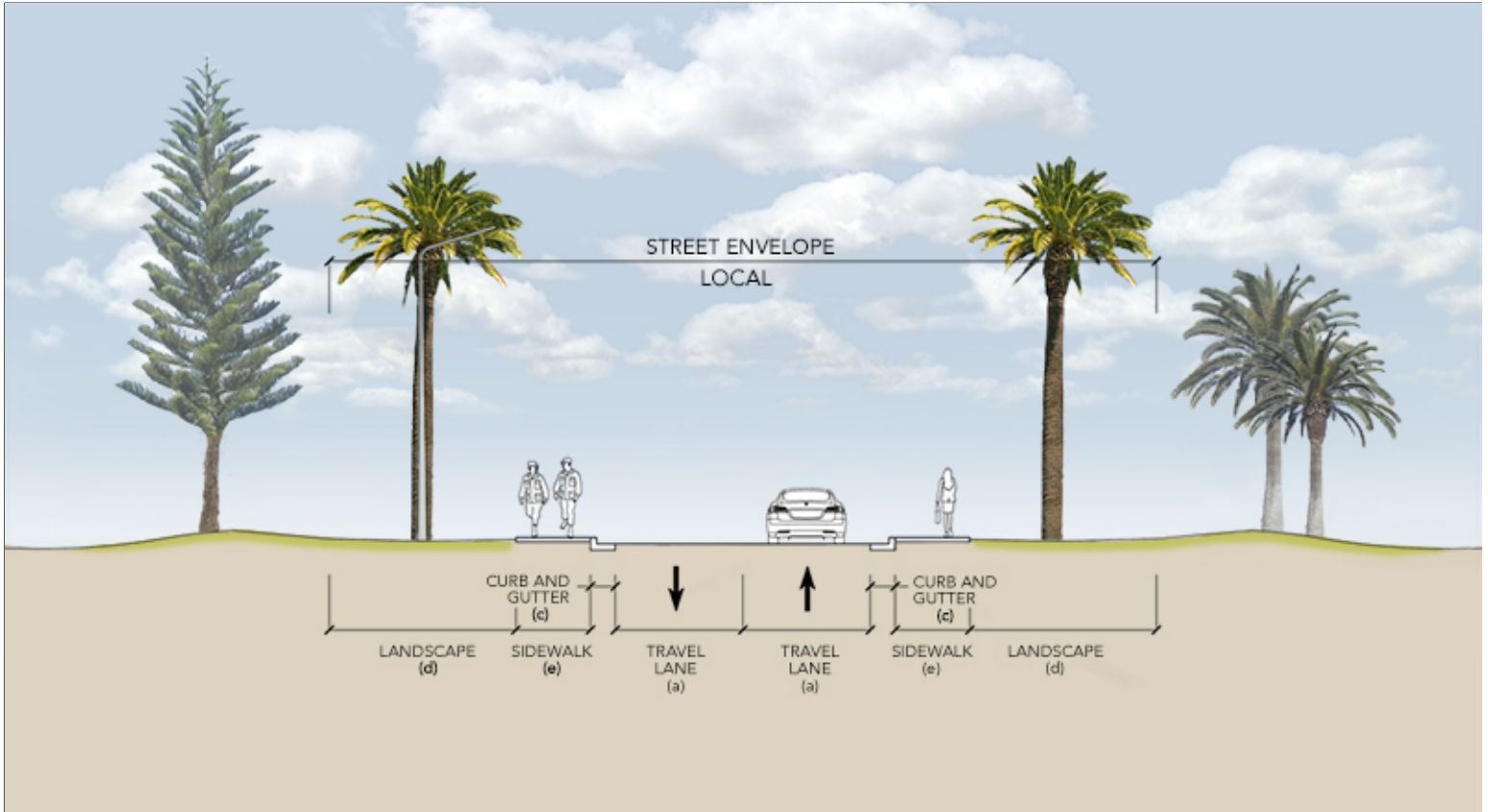

Travel Lane (a): 11' Median (b): N/A Curb and Gutter (c): 1.5' Landscape (d): 15' Sidewalk (e): 6'

1. The remainder of the base streets can be classified as tertiary.
2. Frequent traffic stops and low speeds are permitted on local streets.
3. Provide sidewalks on at least one side of local streets and both sides of local streets where functionally required. Buffers are preferred but not required on local streets.
4. On-street parking may be allowed following UFC industry references.
5. Signs, plantings and street lighting should reinforce the designation of “local” street.
6. Cul-de-sacs are not permitted.
7. Final spacing of trees will depend on the location of utilities, clear zones, drive openings and tree species.

8. Where above ground utilities exist, use street trees as a screen. Street trees used in this manner should not physically interfere with utilities.

B02.1.4. Special Routes

Applicable N/A Large graphics do not apply

Applicable N/A Small graphics do not apply

1. Develop all special routes consistently with those adjacent to Group 1 facilities.
2. Maintain the trees, grasses, landscape beds and setback areas along special routes.

B02.2. Hierarchy of Intersections

Applicable N/A Large graphics do not apply

Applicable N/A Small graphics do not apply

1. Provide a hierarchy of intersections to include arterial, arterial-collector, collector, collector-local and local following UFC 3-201-01 and its industry references.
2. Passive systems such as traffic circles are preferred to active systems such as signalized intersections. Aggressively pursue passive systems to lower maintenance requirements and reduce energy use.
3. Use a level of visual quality for an intersection equal to the quality found in the related streetscape, which corresponds to the adjacent Facility Group number.
4. Landscaping must not block views at intersections and should enhance the intersection area without obscuring visibility. Use flowering trees to distinguish intersections. Place large street trees a minimum of 15 meters (50 feet) from intersections in order to maintain a safe sight triangle.
5. Screen adjacent structures or areas that are unsightly or not meant to be seen. Provide adequate lighting.

B02.2.1. Arterials

Applicable N/A Large graphics do not apply

Applicable N/A Select number of graphics / images (small: 250 px x 188 px) to insert 3

Image Tool 250 x 188



Coordinated Signals and Signing



Coordinated Placement of Poles



Appropriately Scaled Landscape

1. Provide a hierarchy of intersections to include arterial, arterial-collector, collector, collector-local and local following UFC 3-201-01 and its industry references.

2. Passive systems such as traffic circles are preferred to active systems such as signalized intersections. Aggressively pursue passive systems to lower maintenance requirements and reduce energy use.
3. Use a level of visual quality for an intersection equal to the quality found in the related streetscape, which corresponds to the adjacent Facility Group number.
4. Landscaping must not block views at intersections and should enhance the intersection area without obscuring visibility. Use flowering trees to distinguish intersections. Place large street trees a minimum of 15 meters (50 feet) from intersections in order to maintain a safe sight triangle.
5. Screen adjacent structures or areas that are unsightly or not meant to be seen. Provide adequate lighting.

B02.2.2. Arterial/Collector

- Applicable N/A Large graphics do not apply
- Applicable N/A Small graphics do not apply

1. At arterial/collector intersections adjacent to Group 1, landscaping of native grasses and shrubs may be provided; trees may be included when maintenance and non-potable irrigation is available.

B02.2.3. Collectors

- Applicable N/A Large graphics do not apply
- Applicable N/A Small graphics do not apply

1. At collector intersections adjacent to Group 1, landscaping of native grasses and shrubs may be provided; trees may be included when maintenance and non-potable irrigation is available. Intersections adjacent to Group 2 may be developed similarly, but with less detailing.

B02.2.4. Special Intersections

- Applicable N/A Large graphics do not apply
- Applicable N/A Select number of graphics / images (small: 250 px x 188 px) to insert 3

Image Tool 250 x 188

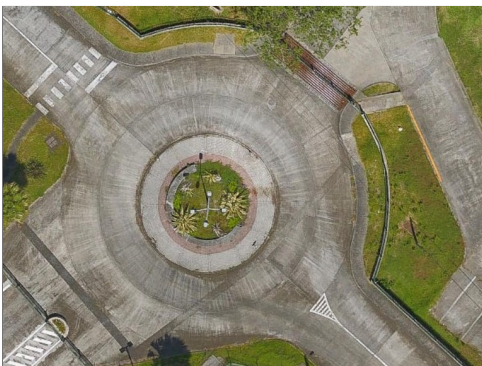

Roundabout



T Intersection with Merge Lanes



Special Route at Green Space

1. Develop all special intersections consistently with those adjacent to Group 1 facilities.

B02.2.5. Street Frontage Requirements

Applicable N/A Large graphics do not apply

Applicable N/A Small graphics do not apply

1. Consistently maintain open space buffers following B03.2.3. Preserves.
2. Refer to C06.1.7. Streetscape Landscaping for planting and screen wall requirements along street frontage.

B02.2.6. Sight Lines

Applicable N/A Large graphics do not apply

Applicable N/A Small graphics do not apply

1. Provide adequate sight lines for an effective and safe traffic operation per American Association of State Highway and Transportation Officials (AASHTO) standards and local municipality guidelines.

B02.3. Street Elements

Applicable N/A Large graphics do not apply

Applicable N/A Select number of graphics / images (small: 250 px x 188 px) to insert 3

Image Tool 250 x 188



Curb



Asphalt Pavement

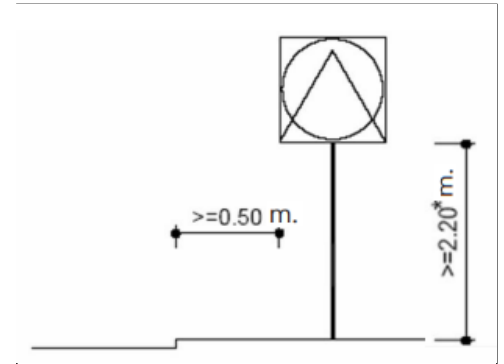

Traffic Signs

1. Emulate the streetscape area's pre-development hydrology using passive and active design features to help sustain the adjacent regionally appropriate landscape.
2. Employ systems, materials and techniques to maximize streetscape sustainability. Consider pervious paving and high reflectivity of surfaces, which are appropriate for the local climate.
3. Install at-grade curbing and/or raised-profile curb and gutter as applicable to direct stormwater to bioswales and rain gardens as source water for vegetation. Do not paint concrete curbing.
4. Provide all on-site utility service lines and equipment below grade when adjacent to Facility Group 1. In routes along Group 2, 3 and 4, when mounting elements such as utility cabinets, communications equipment and water valves above grade is unavoidable, paint these consistently and provide visual screening following Installation Facilities Standards (IFS).
5. Provide traffic control devices including access control point/entry control facility signs, speed limit signs and street name signs following the current edition of the Manual on Uniform Traffic Control Devices (MUTCD) per UFC 3-120-01.

6. Crosswalk markings shall follow the MUTCD for Streets and Highways, current edition. Provide white markings that define the edges of the crosswalk or a tone of lines defining the area of the crosswalk consistent with common practices found in the adjacent municipality.
7. Follow UFC 3-120-01 for directional and wayfinding signs and address both vehicular and pedestrian traffic.
8. Reduce energy consumption and reduce maintenance requirements by providing street lighting only when functionally required to ensure safety and to address antiterrorism following UFC 4-010-01. Ensure the quality and quantities of lighting and fixtures are appropriate for the adjacent Facility Group number.

B02.3.1. Paving

Applicable N/A Large graphics do not apply

Applicable N/A Select number of graphics / images (small: 250 px x 188 px) to insert 5

Image Tool 250 x 188



Asphalt Pavement

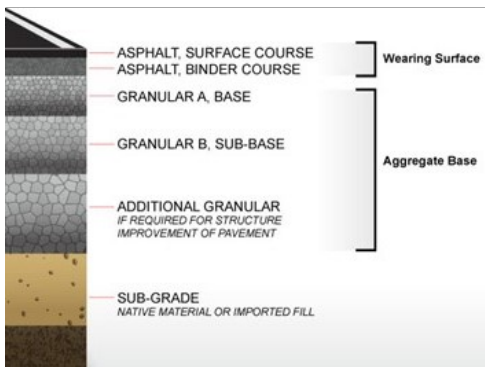

Typical Asphalt Pavement Details



Concrete Pavement



Dowel - Concrete Pavement

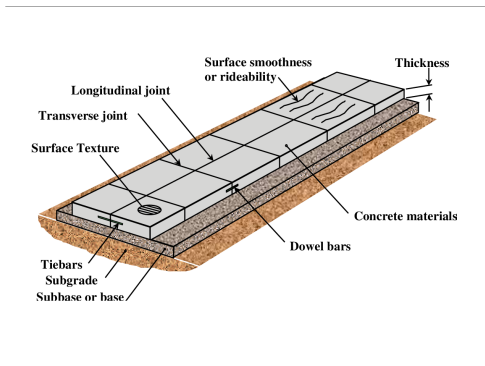

Typical Concrete Pavement Details

1. Pavement design shall comply with UFC 3-250-01. Ensure appropriate analysis and design of subgrade conditions to promote low maintenance, high performance pavements. Apply all applicable best practices from Appendix B of the UFC.
2. Materials shall be specified in accordance with UFC 3-250-01 and must conform to requirements set forth in the Unified Facility Guide Specifications (UFGS) for concrete and bituminous pavement.
3. Pavements at LF may be either concrete or asphalt depending upon the following factors that will impact the material to be used:
 - a. Existing Material to be Replaced
 - b. Adjacent Paving Materials
 - c. Financial Limitations

4. Beach sand must be tested and approved prior to use in concrete mixes. In addition, sand that has not been screened to remove organic material is unacceptable.
5. Hot-mix asphalt pavements usually consist of a 150 mm to 300 mm (6-12 inches) crushed stone base with double or triple application of the asphalt surface treatment. Sub layers are approximately 25 mm (1 inch) thick and the top wear layer is approximately 40 mm to 50 mm (1-1/2 to 2 inches) thick.

B02.3.2. Curb and Gutter

Applicable N/A Large graphics do not apply

Applicable N/A Select number of graphics / images (small: 250 px x 188 px) to insert 6

Image Tool 250 x 188

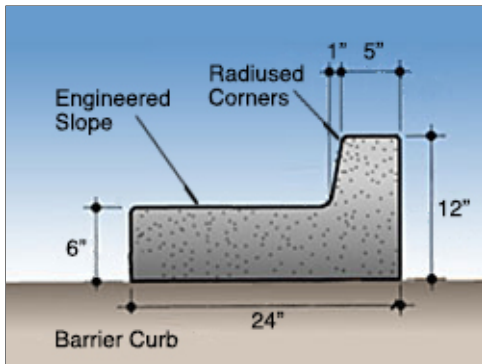

Barrier Curb

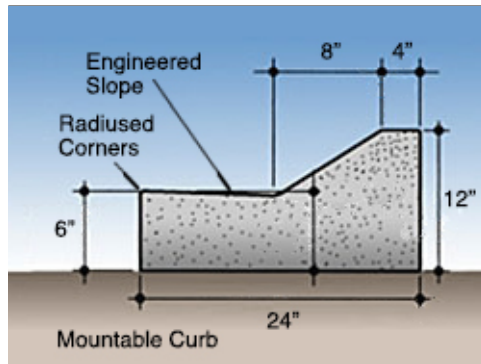

Mountable Curb

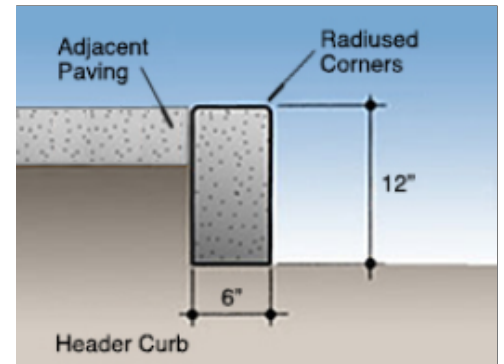

Header Curb



Mountable Curb and Header Curb



Barrier Curb



Cast in Place Curb

1. Curb all streets except remote/isolated roads and rock-paved service roads.
2. All streets should have integral concrete curbs and gutters. Painted curbs are prohibited because they are very difficult to maintain.
3. Use concrete for sidewalks and curbs. Do not use asphalt curbs.
4. Curbs may be cast-in-place, continuous form concrete or precast concrete obtained locally in 1 meter (3 feet) long sections.
5. Ditches are typically cast-in-place, continuous form concrete and should be incorporated along with the curb design.

B02.3.3. Utility Service Elements

Applicable N/A Large graphics do not apply

Applicable N/A Select number of graphics / images (small: 250 px x 188 px) to insert 2

Image Tool 250 x 188



Utility Service Elements - Base Standard Color



Replace Overhead Distribution

1. Provide all utility service lines below grade when streets are adjacent to Facility Group 1; when mounting elements (such as utility cabinets, communications equipment and water valves) above grade is unavoidable, paint these consistently and provide visual screening following Site Development, Landscaping.
2. Overhead service lines along streets adjacent to Facility Groups 2, 3 and 4 are discouraged.

B02.3.4. Traffic Signs

Applicable N/A Large graphics do not apply

Applicable N/A Select number of graphics / images (small: 250 px x 188 px) to insert 5

Image Tool 250 x 188

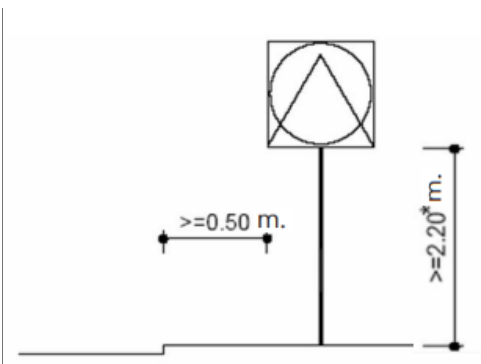

Traffic Signs

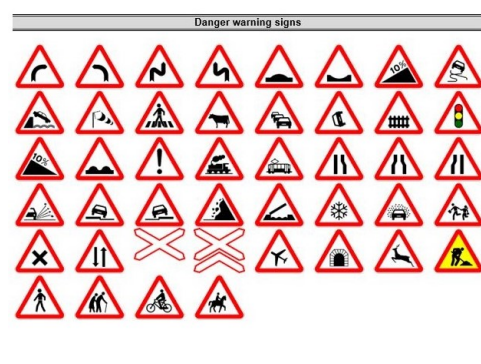

Danger Warning Signs

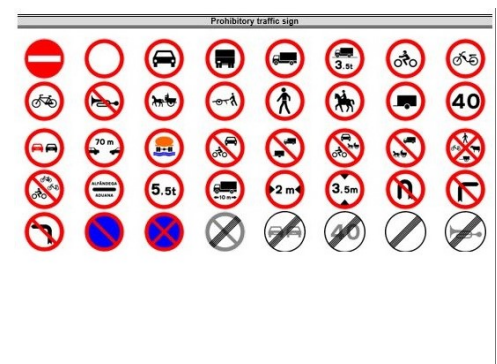

Prohibitory Traffic Signs

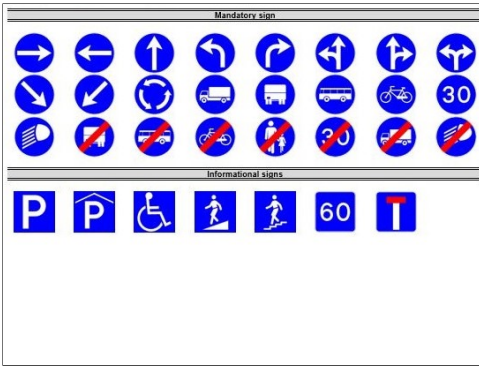

Mandatory & Informational Signs

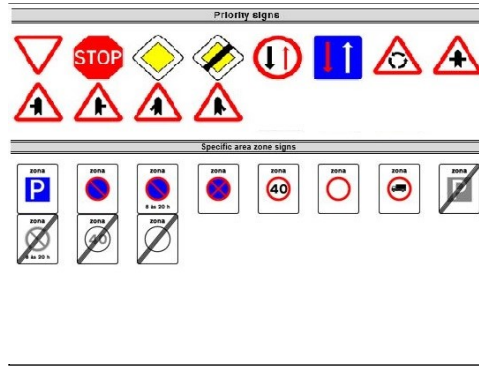

Priority & Specific Area Zone Signs

1. Refer to Exterior Signs, Colors and Types for Traffic Control Devices, which includes signs.
2. Traffic Signs should be compliant with “Disposicoes Normativas” of “Instituto de Infra-Estruturas Rodoviaras”.
3. Sign panels shall be aluminum with a reflective background coating according to the EU vehicle regulatory standards. All installation hardware is to be stainless steel as required.
4. Support posts shall be galvanized steel or stainless steel with a sufficient diameter and thickness to withstand the wind load on Terceira. Typical mounting heights are 2.20 meters (7 feet, 3 inches) from grade to the bottom of the sign. Refer to the EU standards for detailed information.

B02.3.5. Street Lighting

Applicable N/A Large graphics do not apply

Applicable N/A Select number of graphics / images (small: 250 px x 188 px) to insert 3

Image Tool 250 x 188



Street Lighting



Parking lot Lighting



Outdoor Area Lighting

1. Refer to the Lighting section for appropriate applications along streets.

B02.3.6. Other

Applicable N/A Large graphics do not apply

Applicable N/A Small graphics do not apply

B03. OPEN SPACE / PUBLIC SPACE

Comply with Air Force Corporate Standards for Installation Elements:
<http://afcs.wbdg.org/installation-elements/index.html>

Comply with AF Corporate Standards for Open Space / Public Space:
<http://afcs.wbdg.org/installation-elements/open-space-public-space/index.html>

B03.1. Plazas, Monuments and Static Displays

Applicable N/A Large graphics do not apply

Applicable N/A Select number of graphics / images (small: 250 px x 188 px) to insert 3

Image Tool 250 x 188



Plaza



Monument



Static Display

1. Natural features and culturally or historically significant features or events may be recognized and acknowledged with physical elements such as plazas, monuments and static displays. However, limit these elements on the base to ensure judicious use of resources and to reduce ongoing maintenance requirements.
2. Design highly durable plazas, monuments and static displays with a level of quality comparable to Facility Group 1.
3. Link plazas, monuments and static displays to the pedestrian circulation system. Install landscaping, site furnishings and lighting appropriate for the application and local climate following Installation Facilities Standards (IFS).
4. Select systems, products and materials for paving, walls, and structures following IFS.

B03.1.1. Paved Plazas

Applicable N/A Large graphics do not apply

Applicable N/A Select number of graphics / images (small: 250 px x 188 px) to insert 2

Image Tool 250 x 188



Specialty Cobblestone



Concrete Pavers

1. Mitigate heat island effect by providing high-albedo, shaded plazas. Pervious pavers shall be used on all plazas and courtyards in Facility Groups 1 and 2; use pervious concrete in Groups 3 and 4. The designer shall incorporate appropriate expansion and construction joints.
2. Pavers may be stone, similar to traditional Azores pavers and shall typically be 4 x 5 cm or 5 x 7 cm.
3. Dark concrete pavers may also be used in plazas. Use 100 mm (4 inches) of concrete reinforced with welded wire mesh.
4. Place pavers on gravel sub-base and sand setting bed per local practices.

B03.1.2. Sculptures, Markers and Statuary

Applicable N/A Select number of graphics / images (large: 800 px x 440 px) to insert 1

Image Tool 800 x 440

Applicable N/A Small graphics do not apply



Monument with Static Display of Aircraft

1. Relate new sculpture, markers and statuary to the base's architectural design theme. Generally limit these elements to frequently used locations adjacent to Facility Group 1 and highly traveled community pedestrian spaces.
2. Consider entry gates as possible sites for new displays.
3. All proposed memorials shall follow AFI 36-3108 and be limited to highly deserving individuals or groups as deemed appropriate by the installation leadership. Living memorials (tree plantings / etc.) are discouraged due to added maintenance requirements.
4. When sculpture requires a base, match the materials and / or color palette of adjacent buildings.
5. Use direct or indirect lighting to accentuate features or enhance an intended effect.
6. Ensure that all sculpture, markers and statuary are honorable and inspiring, provide a sense of place, positively contribute to the base's visual quality, and encourage pride for the community and the US Air Force.

B03.1.3. Static Display of Aircraft

Applicable N/A Select number of graphics / images (large: 800 px x 440 px) to insert 1

Image Tool 800 x 440

Applicable N/A Small graphics do not apply



Dynamic Mounting of Aircraft

1. Follow IFS base-wide standards for all elements of the display area with specific attention to traffic sight lines, pedestrian circulation, site furnishings, signs, and lighting. Address requirements for the Facility District as well.
2. Generally locate concrete base/foundation structures for static displays below grade.
3. At static displays where pedestrian paths are provided, a minimum of one trash receptacle and one bench shall be provided. Receptacle and bench design must conform to IFS requirements.

B03.2. Grounds and Perimeters

Applicable N/A Large graphics do not apply

Applicable N/A Select number of graphics / images (small: 250 px x 188 px) to insert 3

Image Tool 250 x 188



Buffer Areas



Open Spaces



Steep Slopes

1. Provide formal spaces for parade and review functions, recreational areas and parks following the base's Installation Development Plan (IDP) and Installation Facilities Standards (IFS). Refer to the Site Furnishings topic for additional information.
2. Maintain preservation areas following the IDP and IFS.
3. Comply with UFC 4-010-01 DoD Minimum Antiterrorism Standards for Buildings and UFC 4-022-03 Security Fences and Gates for all elements associated with the base's gates and perimeter fence.
4. Identify and describe base-wide utility corridors in the IDP.
5. Base-wide utility infrastructure shall be inconspicuous. Bury utility service lines below grade when adjacent to Facility Group 1 and when economically feasible for Facility Groups 2, 3 and 4. When service lines are located above grade, create an ordered, coordinated appearance.
6. Follow the requirements of this IFS regarding all utility structures and service lines located above grade that visually impact the installation.
7. Where screening of utility equipment and structures is provided, allow adequate and proper clearance for safety and maintenance.
8. Reduce visual clutter and visual impact of the following items through a combination of careful placement, screen walls, landscaping and painting:
 - Electrical switch-stations
 - Sewage lift stations
 - Water well pumps, storage tanks and/or related structures
 - Gas piping, meters and similar incidental items
 - Above ground fuel storage tanks
 - Any ground-mounted freestanding utility item exposed to view
9. Larger structures such as electrical switch-stations, sewage lift stations, fuel storage tanks and mechanical/electrical equipment shall be screened from view, using materials, forms, and colors in the screen walls that match those respective design elements present at adjacent buildings.
10. Paint aboveground equipment and associated components such as electrical piping or exposed plumbing lines dark bronze.

11. Maintain existing buried utility service lines as a visual asset.
12. Bury the following exposed above-grade items in future projects when economically feasible:
 - Electrical power grid and service lines
 - Telephone lines
 - Cable TV lines
 - Communications lines
 - Exterior lighting service lines
 - Any similar system of above-ground lines serving the base
13. Consolidate and enclose service utility lines in underground utility corridors when feasible. Create routes along the inside edge of parking lot islands.
14. All development of open space requires prior coordination and approval from the 765th ABS Engineering.

B03.2.1. Parade Grounds

Applicable N/A Large graphics do not apply

Applicable N/A Small graphics do not apply

1. Follow UFC 3-201-02, Appendix B for the planning and design process and criteria for parade grounds.
2. Establish and maintain parade grounds only where there is a confirmed need and provide landscape materials appropriate for the locale following IFS.
3. Bleachers may be installed only when there is a documented requirement at parade grounds. Nonferrous metals that do not require painting or ongoing maintenance are preferred. The 765th ABS Engineering shall determine quantities, sizes, and products on a case basis.

B03.2.2. Parks

Applicable N/A Large graphics do not apply

Applicable N/A Select number of graphics / images (small: 250 px x 188 px) to insert 2

Image Tool 250 x 188



Pavilion



Coordinated Playground Equipment

1. Bleachers may be installed only when there is a documented requirement at parks and fields for recreational events. Follow guidance under Parade Grounds.
2. Picnic pavilions may be provided in parks where there is a documented need.
3. Prohibited picnic pavilion materials include wood, concrete masonry units (CMU) or metal pre-manufactured storage sheds. Use only materials and detailing that are low maintenance and endure with minimal weathering.

4. When picnic pavilions are permitted near facilities, generally match the architecture of the adjacent facility and provide a level of quality of the adjacent facility group number.

B03.2.3. Preserves

Applicable N/A Large graphics do not apply

Applicable N/A Small graphics do not apply

1. Preserve areas adjacent to runways, taxiways, aprons, golf course roughs, storage areas, antenna facilities, and ammunition storage areas as open space.
2. Provide minimal maintenance with mowing as needed for controlling bird behavior for airfield safety or eliminating fire hazards.

B03.2.4. Perimeter Fence

Applicable N/A Large graphics do not apply

Applicable N/A Select number of graphics / images (small: 250 px x 188 px) to insert 9

Image Tool 250 x 188



Base Perimeter and Controlled Area Fence

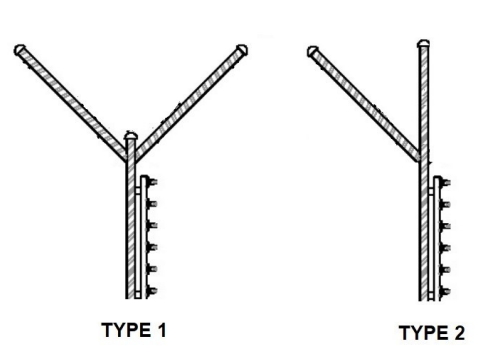

Fence Outrigger Types

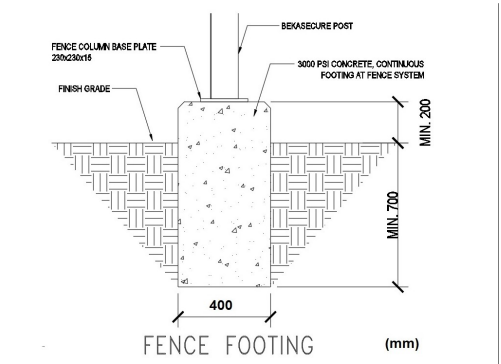

Fence Foundation - Type 1

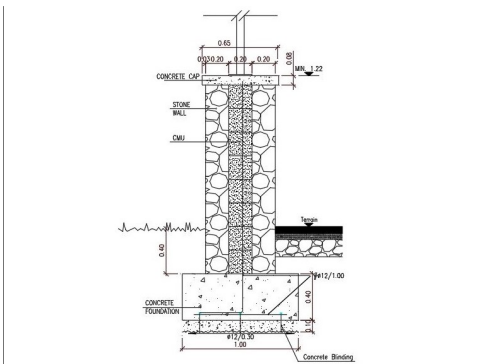

Fence Foundation - Type 2



L-Profile



Spider Fixation



Surface Mount with Base Plate

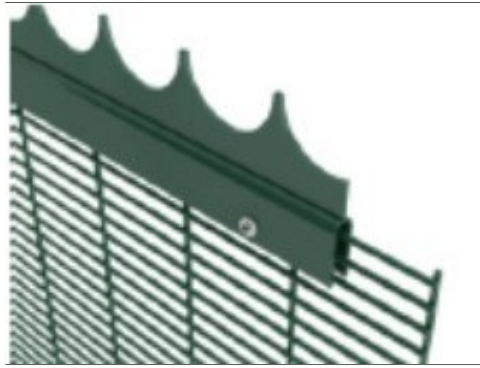

U-profile with Dental Strip



Anti-Ram Vehicle Cable System

1. Design, install and maintain the base's perimeter fence following UFC 4-022-03.
2. Stringently comply with ATFP requirements following UFC 04-010-01 for all spaces adjacent to the base's perimeter fence and all gates.
3. Fencing, gates and other elements that are associated with the main gates shall be a level of quality equivalent to Facility Group 1.
4. Maintain a positive visual quality along the traffic corridor on both sides of the main gates. Specifically address pedestrian access, circulation and common areas.
5. Base perimeter and controlled area fencing in most areas shall be the Securifor 2D or similar welded mesh fencing system with triple strand razor wire on outriggers angling out at the top. These panels shall have a zinc-aluminum alloy coating and finished with a marine grade polyester coating (RAL 6005). The welded mesh pattern of the panels (H x W) will be 12.7mm x 76.2mm, composed by horizontal wires with 4mm diameter at 12.7 mm and intermittent 4 mm double wires at 152.4 centers to centers on the inside face and vertical wires with 6mm in diameter.
6. All main base perimeter fencing shall be 2.5 meters (8 feet) tall and shall utilize a concrete or stone wall base to prevent access from underneath.
7. Utilize galvanized steel rectangular posts with base plate (min. 275 g/m²) with a zinc-aluminum alloy coating and finished with a marine grade polyester coating (RAL 6005), finished to match the green coating on the mesh. The posts have a single row of M8 threaded inserts. The panels are fixed using spider fixator. Support posts to be pointed away from the base interior and mounted on a continuous concrete foundation to prevent tunneling. Utilize Type 1 fence outrigger with razor wire when there is sufficient space between fence and public road, situations where spacing between public road and fence doesn't allow secure public circulation utilize type 2 outrigger. All fasteners used shall be stainless steel 316L.
8. Additionally, in order to obtain a higher rigidity of the panel on the top, it may require the addition of U-profile with dental strip, fixed with bolts ISO 7380 M6x25, M6 washer and nut (all in Stainless Steel 316 L).
9. To obtain a higher rigidity at the bottom of the panel, it may require the addition of an L-profile (40x40x4mm), all fasteners shall be in Stainless Steel 316 L.
10. Anti-Ram Vehicle cable is installed to protect the base and airfield perimeter from incoming terrorist attacks via land, using a motorized vehicle by ramming existing fence.

C. SITE DEVELOPMENT

Comply with Air Force Corporate Standards for Site Development:
<http://afcs.wbdg.org/site-development/index.html>

C01. SITE DESIGN

Comply with Air Force Corporate Standards for Site Development:
<http://afcs.wbdg.org/site-development/index.html>

Comply with AF Corporate Standards for Site Design / NEPA:
<http://afcs.wbdg.org/site-development/site-design-nepa/index.html>

C01.1. Site Design Considerations

Applicable N/A Large graphics do not apply

Applicable N/A Select number of graphics / images (small: 250 px x 188 px) to insert 3

Image Tool 250 x 188



Preserved Natural Features



Accommodating Terrain



Standard Sidewalk System

1. Collect documentation to validate approvals and completion of the NEPA process.
2. Ensure site design compliance with the Installation Development Plan (IDP) and its component plans and Installation Facilities Standards (IFS).
3. Promote integrated design with on-site solutions such as engineered small-scale hydrologic controls versus base-wide infrastructure; consider open space, natural features, bioswales, building roofs, streets, and paved surfaces.
4. Limit the impact of development on land and water resources. All site elements and infrastructure shall reinforce an image of sustainability, with reduced energy demand, renewable-energy usage, and water conservation.
5. Consider energy conservation during site design for the following categories: building and site lighting, auxiliary systems and equipment (refrigerators, elevators, etc.), building envelope, electric power and distribution, HVAC systems and equipment, service hot water, and energy management (metering, EMCS).
6. Coordinate on-site renewable-energy systems and components to minimize area requirements and maximize efficiencies. Appropriately buffer and screen these and other mechanical systems and equipment.
7. New building projects should preserve open space and protect natural habitat.
8. Define open residual space between buildings with lawn and specimen trees. Where possible, frame open areas and create enclosed views between buildings. Utilize trees and shrubs that serve as screens to provide shade. Landscape plantings in clusters create seasonal interest near buildings and the edges of residual space. Break up large, open residual space with pedestrian walks and canopy trees, where appropriate. Plan and preserve open spaces that are important to visual continuity. Connect facilities using residual open spaces and trails.

9. Use natural areas for trails, when appropriate. Maintain the edges of natural areas to control endemic and invasive plant species. Encourage the reforestation and development of natural areas in unused open spaces and perimeter areas to reduce maintenance. Combine or connect planned buffers to natural areas, where appropriate. Minimize mowing and plant maintenance along roadside natural areas by planting indigenous plantings between the area edge and 6 meters (20 feet) from the road edge.
10. Conform to existing topography to the greatest extent possible and use slopes to increase site and building efficiencies. Design sites to minimize irrigation and impacts to stormwater runoff.
11. Steep slopes that are readily visible shall be visually enhanced with low maintenance, indigenous vegetation. Where steep slopes cover large areas or offer passive recreational opportunity, make connections to pedestrian systems. Use mesh or similar material to stabilize the slope prior to planting. Use gabion walls or dry-laid stone, when required, to create terraces. Stabilize slopes with ornamental grasses, hardy perennials and low growing ground covers. Use railing or low walls when paths are adjacent to the top of steep slopes. Use ramps, when possible, to provide access between level surfaces and adjacent slopes.
12. Carefully study new project sites to identify the character of adjacent buildings, streets, landscaping, and site design elements. Reinforce the existing character in new site design.
13. Consider relationships to adjacent facilities and district / centralized heating and cooling infrastructure and cost effectively connect building systems to harvest heat, grey water or other beneficial byproducts.
14. Minimize existing and planned obstructions from landscaping, structures, topography, and adjacent developments to preserve solar access and natural ventilation.
15. Purposefully integrate service access, receiving and storage areas to eliminate the need for visual screening.
16. Appropriately connect to the base network of streets, sidewalks and trails using drive aisles, parking areas, walkways, paths, and bicycle routes addressing both vehicles and pedestrians.
17. Applicably coordinate heat island mitigation in paving and roof designs when implementing an integrated approach to stormwater management.
18. Consider the location of "Designated Tobacco Areas."

C01.2. Building Orientation

Applicable N/A Select number of graphics / images (large: 800 px x 440 px) to insert 1

Image Tool 800 x 440

Applicable N/A Select number of graphics / images (small: 250 px x 188 px) to insert 6

Image Tool 250 x 188

DRIVING FACTORS

- | | | | |
|--|--|--|---|
| • Optimal solar orientation of the building. | • Maximize the daylight & desirable views. | • Meet the required AT/FP standoff distance | • Create a unified campus |
| • Main entrance from Pepperrell street. | • Saving existing vegetation and trees | • Separation between staff/public/materials entrance | • Outdoor healing environment |
| • Addressing the orientation of the future ACC | • Visibility of the new facility from main roads | • Required parking spaces for public and staff | • Implementation of landscape zones A, B, C & D |

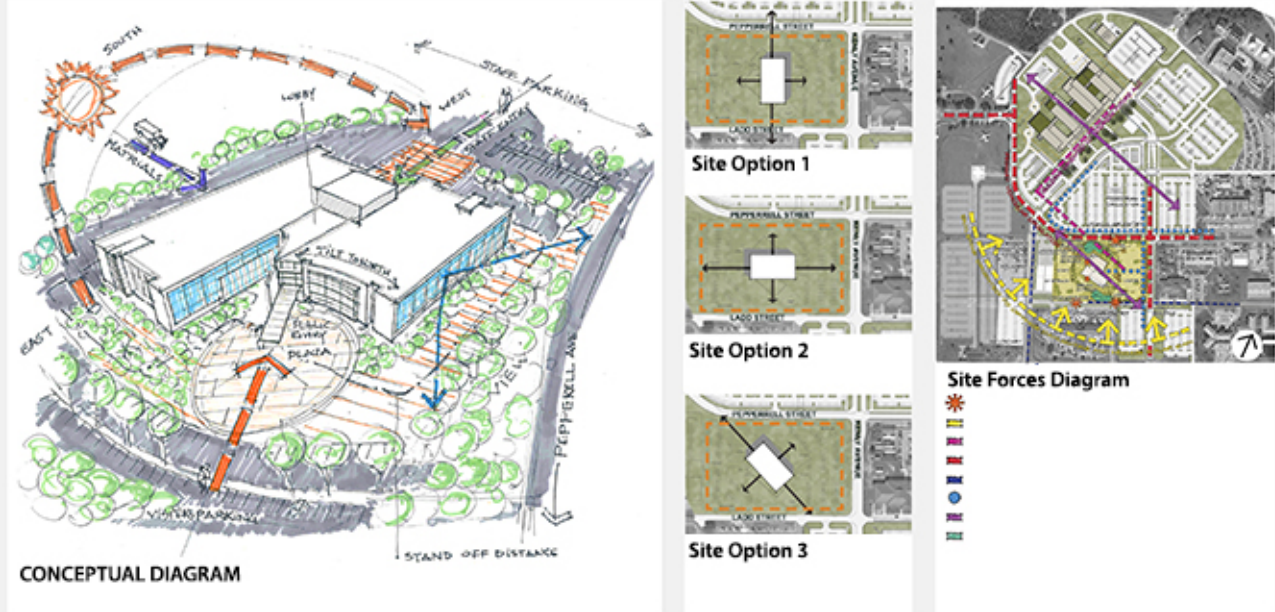

Conceptual Site Analysis and Site Design Diagram

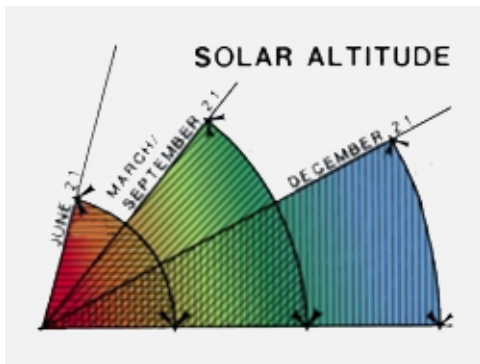

Local Solar Data

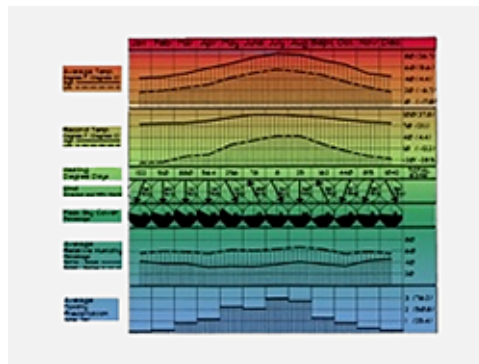

Local Climate Data

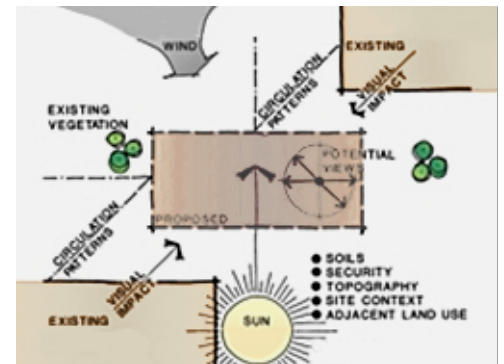

Site Data

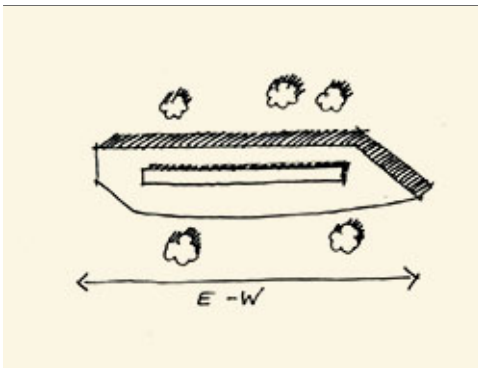

East-West Axis

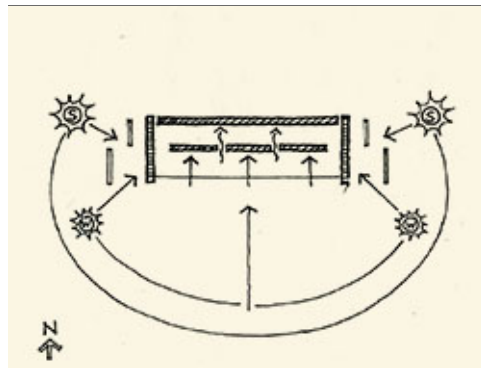

Optimum Solar Control

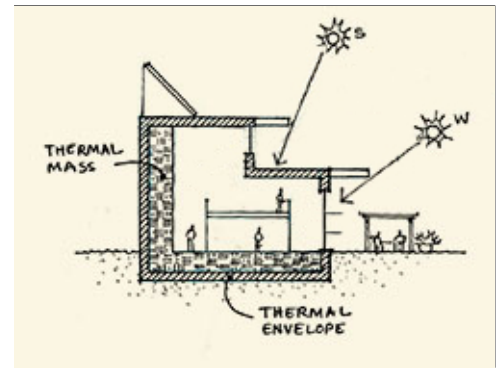

Maximized Shading

1. Ensure the site will accommodate optimum requirements for building orientation, which is with the long axis parallel to the east/west direction for rectilinear CONUS buildings.
2. Meet Installation Facilities Standards (IFS) requirements for the locations of the building's passive and renewable-energy systems --including geothermal and solar systems --and exterior shading systems.
3. Locate the building(s) and permitted ancillary structures to promote solar gain, solar shading, natural ventilation, rainwater harvesting, wind buffering and other beneficial passive systems. Consider natural ventilation during the design of HVAC systems.
4. Consider relationships to adjacent sites and their facilities and infrastructure, and cost effectively integrate building systems to harvest heat, grey water or other beneficial byproducts.
5. Consider the "public side" of the building, its views and the location of the main entrance.

C02. UTILITIES

Comply with AF Corporate Standards for Site Development:

<http://afcs.wbdg.org/site-development/index.html>

Comply with AF Corporate Standards for Utilities:

<http://afcs.wbdg.org/site-development/utilities/index.html>

C02.1. Utility Components

Applicable N/A Large graphics do not apply

Applicable N/A Select number of graphics / images (small: 250 px x 188 px) to insert 4

Image Tool 250 x 188



Azorean Stone Wall with Concrete Cap



Main Base Building Screen



Screeno Line with Concrete Base



Screeno Wave

1. Provide all on-site utility service lines below grade for Facility Group 1; when mounting elements (such as utility cabinets, communications equipment and water valves) above grade is unavoidable, paint these consistently and provide visual screening following Installation Facilities Standards (IFS).
2. Provide installation of utility infrastructure to support near term and future electric vehicle charging stations.
3. Define all service entry points into the building and route distribution below grade into an interior space within the facility; exposed conduits, cables and wires on exterior walls are not permitted for Facility Group 1.
4. Include consideration of appropriate placement of meters in support of Automated Revenue Management Services (ARMS).
5. Limit exterior mechanical distribution systems such as exterior steam, chilled water, and hot water distribution to Group 3 facilities; when required for Group 1 and 2 facilities integrate with the architecture and provide visual screens following IFS.
6. Direct roof drainage to underground collection when feasible or provide splash blocks / paved channels to intercept roof drainage at grade.
7. Fire hydrants shall comply with conventional U.S. standards and codes. Wet barrel fire hydrants are the base standard. Dry barrel hydrants are not acceptable. Fire hydrants will be color coded based on the type of distribution system to which they are connected as well as their rated capacities. Color-coding standards for fire hydrants are as follows:
 - a. All hydrant barrels connected to potable systems will be painted dark brown. Hydrant barrels connected to non-potable systems will be painted tan;
 - b. All bonnets and cap will be painted the following colors based on their rated capacities, for rapid identification at night, bonnet colors will be reflective in accordance with NFPA Standard 291:
 - i. Class AA - rated capacity of greater than 1500 gpm - Light Blue
 - ii. Class A - rated capacity of 1000 to 1499 gpm - Green
 - iii. Class B - rated capacity of 500 - 999 gpm - Orange
 - iv. Class C - rated capacity of less than 500 gpm - Red
 - c. Exceptions will be those Installations where Host Nation (HN) standards drive a variance from this requirement. Installations that are able to comply with this guidance should correct hydrant color coding by attrition during regularly scheduled maintenance cycles.If necessary, Fire Hydrants shall be protected with curbs. Do not use bollards.
8. Site screens and walls control unsightly views and protect privacy. Site screens and walls shall be selected from the following types as shown:
 - a. Azorean stone wall with concrete cap.
 - b. Azorean stone wall with a PVC screen fencing, similar to SCREENO WAVE or SCREENO LINE by BETAFENCE.
 - c. PVC screen fencing, similar to SCREENO WAVE or SCREENO LINE by BETAFENCE and concrete or CMU base and supports painted Cream Beige (RAL 1015).
9. Screen walls attached to buildings or detached screen walls on the main base should be utilized to screen HVAC, electrical, dumpsters and other equipment from view. Screen walls must maintain required airflow and maintenance

clearances between the wall and the screened element. The height of screen walls may vary, and screens should always be a minimum of 150 mm (6 inches) taller than the element being screened. Screen walls on the main base should be two-sided masonry enclosures utilizing open terra-cotta clay units with a flower pattern or similar design that allows the appropriate airflow required, but still visually screens the equipment from view.

10. Refer to UFC 3-420-01 Plumbing Systems, the Uniform Plumbing Code for detailed reference information and the European Codes 806 E and EN 12056.
11. Backflow prevention devices shall be provided on all facility main water lines, HVAC water make-up lines and fire protection systems lines. Check valves only are not acceptable backflow prevention. Valve and backflow prevention boxes may be site-cast from concrete.
12. Facilitate maintenance and reduce costs by using readily available European materials, such as PPR pipes, which are suitable for cold and hot water, for pressurized plumbing and mechanical systems. Multilayer pipe with Seamless Aluminum Composite is recommended; RTM Uponor accessories are recommended for diameters of 16mm, 20mm, 25mm and 32mm or equivalent.
13. Exterior plumbing may be C900 PVC over 100 mm (4 inches) in diameter. Schedule 80 PVC is used for 100 mm (4 inches) diameter and below. Use cast iron pipe or PVC with appropriate joints for waste piping. Use hubless cast iron or PVC for making repairs or minor renovations in existing cast iron systems. Replace existing cast iron vertical stacks with PVC or repair with cast iron components. Do not use galvanized piping.
14. Drinking water test parameters should be compliant with *Decreto-Lei n.º 306/2007, de 27 de Agosto* and tested pesticides indicated by *Direção Regional do Desenvolvimento Agrário*.
15. Roof penetrations shall be kept to a minimal by combining plumbing vent lines. Grease traps and oil interceptors shall be located on the outside of an exterior wall.
16. Sewer systems may be ductile iron, PVC pipes and local materials. Structures may be cast-in-place from concrete block or poured-in-place concrete and precast manhole sections. Frames, covers and manhole step components are generally metal.
17. Use yellow as a safety measure to improve the visibility of storm drains. Pipe materials may be concrete or PVC, up to 600 mm (2 feet). Storm structures shall be constructed of concrete block, poured-in-place concrete or precast manhole sections. Utilize rain leader splash blocks, similar to existing on base.
18. For information regarding Office Area Plumbing Fixtures and Equipment, please see Appendix G.

C03. PARKING AREAS

Comply with AF Corporate Standards for Site Development:

<http://afcfs.wbdg.org/site-development/index.html>

Comply with AF Corporate Standards for Parking Areas:

<http://afcfs.wbdg.org/site-development/parking-areas/index.html>

C03.1. Configurations and Design

Applicable N/A Large graphics do not apply

Applicable N/A Select number of graphics / images (small: 250 px x 188 px) to insert 3

Image Tool 250 x 188

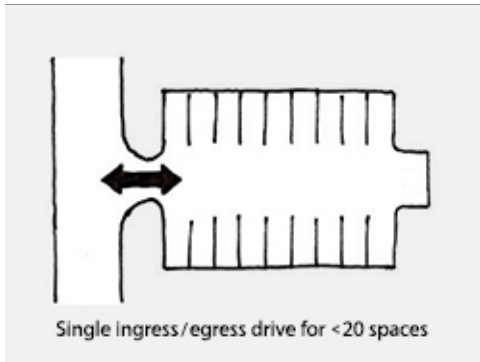

Small Lot Configuration

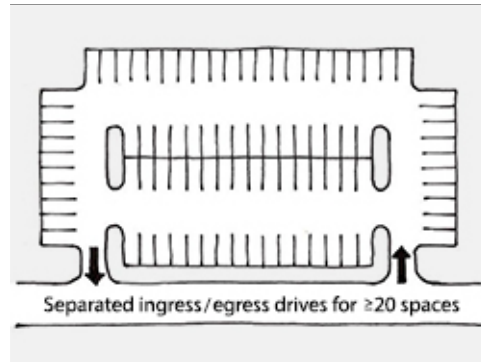

Large Lot Configuration

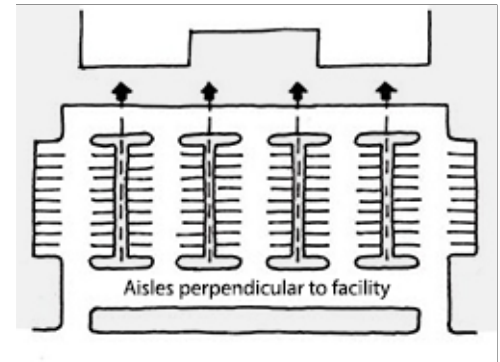

Facility Group 1 Configuration

1. Parking areas should be set back from streets a minimum 6 meters (20 feet) width and from buildings a minimum 3 meters (10 feet) width to allow adequate space for screen plantings, however requirements for AT/FP and other applicable legislation may require more distance between buildings and parking and roads.
2. Evaluate adjacent sites and cost-effectively consolidate parking areas to maximize efficient use; ensure that all areas meet accessibility guidelines.
3. Generally envision on-site parking as a series of small connected singular areas selectively placed around the facility served, rather than a single large area; buffer parking areas from the facility main entrance with a transition space and provide drop-offs to decrease close-in parking. Comply with IFS while meeting ATRP requirements.
4. Integrate at-grade and raised-profile curbing, permeable paved areas, and parking islands with the stormwater system and direct stormwater to bioswales and rain gardens as source water for regionally appropriate native vegetation.
5. Define pedestrian access with approved hardscape and provide shading along the primary path from the parking area to the building's main entrance.
6. Coordinate suitable landscape or barriers integrated with walls and fences to ensure adequate force protection.
7. Accessible parking spaces must conform to international European standards.
8. Consider locations and requirements of near term and future electric vehicle charging stations.
9. Designate preferred parking spaces for electric vehicles and carpools near the main entrance.
10. Consider cost-effectively integrating solar photovoltaic arrays into covered parking structures.
11. Reserved parking is discouraged except for Facility Group 1.
12. On-street parking is discouraged except in multi-use areas. When used, provide approved on-street parking configurations following UFC 3-201-01.
13. Access and service drives should accommodate the largest vehicle serving the facility.

C03.1.1. Paving and Striping

Applicable N/A Large graphics do not apply

Applicable N/A Select number of graphics / images (small: 250 px x 188 px) to insert 5

Image Tool 250 x 188



Permeable Pavers



Specialty Cobblestone



Typical Bituminous Paving



Standard White Striping



Integrated Concrete Pads

Facility Group 1 paving materials shall be as follows.

- Primary: Bit. Pavement, Pervious or Interlocking Pavers
- Secondary: Stone Pavers (Azores Heritage)
- Accent: Stone Pavers may define walkways (Optional)

Facility Group 2 paving materials shall be as follows.

- Primary: Bit. Pavement, Pervious or Interlocking Pavers
- Secondary: Bituminous Pavement
- Accent: N/A

Facility Group 3 paving materials shall be as follows.

- Primary: Bituminous Pavement
- Secondary: Concrete Pavement
- Accent: N/A

Facility Group 4 paving materials shall be as follows.

- Primary: N/A
- Secondary: N/A
- Accent: N/A

1. All new parking lots in Group 1 shall be constructed of bituminous paving in traffic lanes and use Pervious Pavers or Interlocking pavers at parking spaces. Concrete or stone edge barrier (6" wide by 12" deep) shall be utilized between traffic lanes and parking spaces when applied different types of pavements and may be used to divide parking spaces.

2. Cost-effectively provide light-colored concrete to reduce heat island effect; otherwise install bituminous pavement. Dirt, gravel, and grass lots are not allowed.
3. Use consistent striping, angles and stall sizes in all parking areas.
4. All parking shall be marked with white stripes of paint or applied vinyl coatings. Red or yellow markings shall only be used for safety purposes and must be kept to a minimum. All lines shall be four inches (4") wide.
5. Refer to Appendix G for supplementary information regarding pavement markings.

C03.1.2. Curbing

Applicable N/A Large graphics do not apply

Applicable N/A Select number of graphics / images (small: 250 px x 188 px) to insert 6

Image Tool 250 x 188

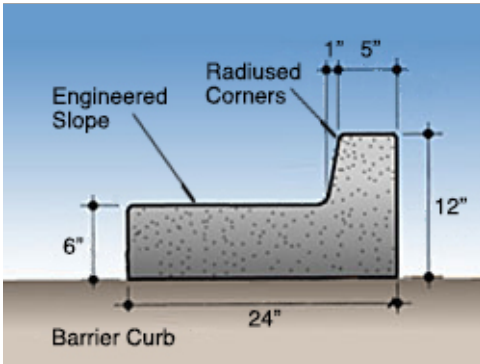

"Barrier" Curb

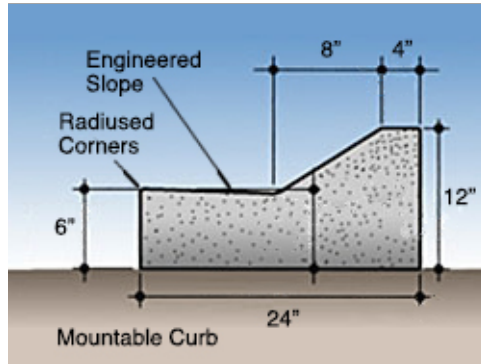

"Mountable" Curb

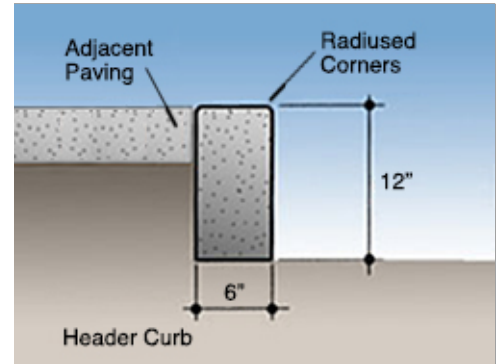

Header Curb



Standard Integral Section



Segmented Curb



Transition in Grade

Facility Group 1 curbing / edging materials shall be as follows.

Primary: Concrete

Secondary: Stone

Accent: N/A

Facility Group 2 curbing / edging materials shall be as follows.

Primary: Concrete

Secondary: N/A

Accent: N/A

Facility Group 3 curbing / edging materials shall be as follows.

Primary: Concrete

Secondary: N/A

Accent: N/A

Facility Group 4 curbing / edging materials shall be as follows.

Primary: N/A

Secondary: N/A

Accent: N/A

1. Define all parking lots with either raised-profile or at-grade curbing to promote drainage and protect paving edges.
2. Integrate curbing to direct stormwater to bioswales and rain gardens as source water for regionally appropriate native vegetation.
3. Wheel stops are not permitted except at locations where vehicle bumpers could contact adjacent items such as poles, signs or pedestrians.

C03.1.3. Internal Islands and Medians

Applicable N/A Large graphics do not apply

Applicable N/A Select number of graphics / images (small: 250 px x 188 px) to insert 3

Image Tool 250 x 188



Contrasting Islands

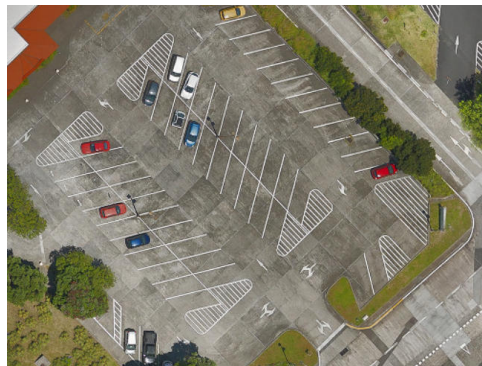

Striped Islands

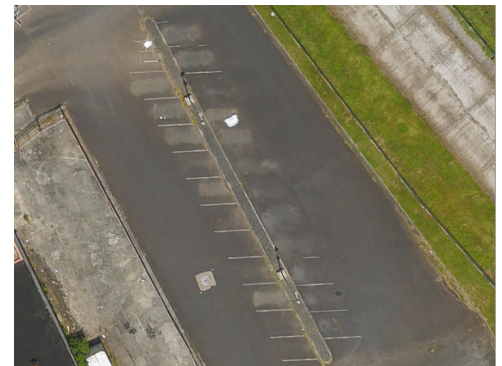

Central Median

1. Install landscape islands and medians as visual breaks, to reduce heat island effects and to accommodate bioswales and rain gardens. Coordinate suitable landscape or barriers integrated with walls and fences to ensure adequate force protection.
2. When lighting is necessary, contain fixture bases within medians or internal landscape islands.

C03.2. Parking Structures

Applicable N/A Large graphics do not apply

Applicable N/A Small graphics do not apply

1. Parking structures are encouraged in land-constrained locations when economically feasible.
2. Consider near-term and future electric vehicle charging stations and renewable energy generation development during the analysis and design.
3. Consider opportunities for integrating parking structures into multi-use developments with pedestrian-oriented uses on the ground floor and parking on upper levels; ensure AFTP guidelines are fully addressed.
4. Structures may be constructed below grade with roofs serving as vegetated areas or plazas.

C03.3. Connectivity

Applicable N/A Large graphics do not apply

Applicable N/A Small graphics do not apply

1. Refer to the Installation Development Plan (IDP) for locations of transit stops and pedestrian and cycling networks; provide appropriately sized sidewalks and bike paths to connect facilities and users to these networks.
2. Provide amenities such as rain and shade shelters, trees, and benches to encourage and facilitate use of public transportation.
3. Evaluate the IDP for the current and planned network of roads and optimally develop vehicular access to and from the site.

C04. STORMWATER MANAGEMENT

Comply with AF Corporate Standards for Site Development:

<http://afcs.wbdg.org/site-development/index.html>

Comply with AF Corporate Standards for Stormwater Management:

<http://afcs.wbdg.org/site-development/stormwater-management/index.html>

C04.1. Stormwater Requirements

Applicable N/A Large graphics do not apply

Applicable N/A Select number of graphics / images (small: 250 px x 188 px) to insert 1

Image Tool 250 x 188



Typical Storm Drain

1. Heavy rainfall occurs in the winter season with storms of short duration. Roof water is typically not retained for domestic use.
2. The ground water table is close to the surface in late winter and early spring in some locations and well point pumping may be required. Do not use corrugated metal piping under any circumstances.

3. Design all stormwater systems including retention ponds, detention areas, channels, etc. as on-site amenities that are consistent with natural systems and drainage patterns, that help sustain the base landscape with beneficial functionality and that provide aesthetic appeal; coordinate with the base Stormwater Management Plan.
4. Incorporate bioswales into the design of all roadway, parking and facility roof systems to enhance water quality and support the overall stormwater system.
5. Permeable paving may be used.
6. Provide rainwater harvesting and storage that is attached to the building's roof drain systems to support grey water irrigation.
7. When underground drainage systems are required establish a maintenance program to include removal of sediments and debris; inspect joints seasonally for alignment to prevent leakage and the development of voids and surface failures.
8. Cost-effectively integrate stormwater systems with ATRP measures.

C05. SIDEWALKS, BIKEWAYS AND TRAILS

Comply with AF Corporate Standards for Site Development:

<http://afcs.wbdg.org/site-development/index.html>

Comply with AF Corporate Standards for Sidewalks, Bikeways and Trails:

<http://afcs.wbdg.org/site-development/sidewalks-bikeways-trails/index.html>

C05.1. Circulation and Paving

Applicable N/A Large graphics do not apply

Applicable N/A Select number of graphics / images (small: 250 px x 188 px) to insert 3

Image Tool 250 x 188



Attached Sidewalk



Curb Ramps



Unit Pavers at Trail

Facility Group 1 sidewalks, plazas, and courtyards paving materials shall be as follows.

Primary: Stone Cobblestone and Stone Edging

Secondary: Concrete Paving and Edging

Accent: Colored Concrete (Optional)

Facility Group 2 sidewalks, plazas, and courtyards paving materials shall be as follows.

Primary: Stone Cobblestone and Stone Edging

Secondary: Concrete Paving and Edging

Accent: Colored Concrete (Optional)

Facility Group 3 sidewalks, plazas, and courtyards paving materials shall be as follows.

Primary: Pervious Pavers

Secondary: Concrete Paving and Edging

Accent: N/A

Facility Group 4 sidewalks, plazas, and courtyards paving materials shall be as follows.

Primary: N/A

Secondary: N/A

Accent: N/A

1. Maintain efficient geometry and accessibility to connect building entrances to adjacent parking areas and activity areas and to the base transportation system following AFTP. Efficiently use materials to optimize life-cycle costs and to minimize maintenance.
2. Generally conform horizontal layouts of sidewalks to the geometric configuration of adjacent buildings, streets, parking lots, and other adjacent related site amenities. Occasional meanders and/or jogs may be included to capture views, to coordinate with landscaping or accommodate site constraints.
3. Walks in parking areas shall provide a direct path using "safe islands" and "peninsulas" to encourage safety. Walks parallel to streets shall follow streetscape guidelines. Clearly mark pedestrian crossings at vehicular routes.
4. Mitigate heat island effect by providing high-albedo, shaded sidewalks. Pervious pavers shall be used on all sidewalks, plazas and courtyards in Facility Groups 1 and 2; use pervious concrete in Groups 3 and 4. The designer shall incorporate appropriate expansion and construction joints.
5. Only experienced contractors will install pervious pavements.
6. Consider an integrated approach that could include stormwater management (permeable surfaces) and complement the design of the storm drainage system when appropriate.
7. Pedestrian paths should be at least 5' in width to allow for comfortable side-by-side walking.
8. Sidewalks leading to a building main entrance and at the interior of parking lots shall be a minimum width of 6'. Walks greater than 10' wide may be used at high-density pedestrian areas where volumes of traffic justify added material.
9. Where vehicles park adjacent and head-in to the sidewalk and wheel stops are not used, such perimeter walks shall be increased to a minimum width of 8' to accommodate overhangs of the parked vehicles.
10. All sidewalks shall have positive drainage to prevent ponding of water with slopes ranging from 2.1% to 4.2%. Walks with a slope greater than 4.2% shall be designed as ramps following accessibility guidelines. All walks shall have a minimum cross slope of 2.1%.
11. Pavers shall conform to the following range of color: Grey (Concrete). Pavers used on walks shall typically be similar to those in use. Match the existing pavers for small repairs.
12. Connect to the bicycle circulation system and provide bicycle parking with a suitable means for securing bicycles following IFS. Consider changing/shower facilities for use by cyclists.
13. Refer to the Installation Development Plan for future trails, bicycle paths, and sidewalks.

C05.1.1. Ramps and Stairs

Applicable N/A Large graphics do not apply

Applicable N/A Select number of graphics / images (small: 250 px x 188 px) to insert 6

Image Tool 250 x 188



Accessible Ramps



Natural Color Concrete Steps



Stainless Steel Railing



Natural Color Concrete Steps



Brass Safety Nosings



Lava Rock Stairs in Special Area

1. Use ramps instead of stairs for sidewalks, bikeways and trails and at all buildings where possible. Where steps are unavoidable, follow UFC 1-200-01 and its references to the International Building Code.
2. All new railings shall be surface mount with a base plate, fasteners and accessories shall be in Stainless Steel 316L or aluminum.
3. Do not paint concrete steps. Provide brass stair nosings where functionally required; use lava rock stairs in special areas.

C05.1.2. Lighting

Applicable N/A Large graphics do not apply

Applicable N/A Small graphics do not apply

1. Provide lighting for all stairs and landings where traffic warrants.
2. Refer to the Lighting section for path lighting along sidewalks, bikeways and trails.

C06. LANDSCAPE

Comply with AF Corporate Standards for Site Development:
<http://afcs.wbdg.org/site-development/index.html>

C06.1. Climate-based Materials

Applicable N/A Large graphics do not apply

Applicable N/A Select number of graphics / images (small: 250 px x 188 px) to insert 5

Image Tool 250 x 188



Integrated AT Setback Requirements



Hydrangea



Lava Rock Landscaping with No Plants



Climate Supported Plant Species



Indigenous Trees and Shrubs

1. Use only native, naturally occurring, drought tolerant indigenous plant species (including grasses) appropriate for the locale to promote energy efficiency and water conservation, preserve drainage patterns, inhibit erosion, improve air quality, lower maintenance, and add beauty.
2. Refer to Appendix G for supplementary information.

C06.1.1. Landscape Design Concept

Applicable N/A Large graphics do not apply

Applicable N/A Select number of graphics / images (small: 250 px x 188 px) to insert 5

Image Tool 250 x 188



Native Trees and Grasses



Native Shrubs



Trees Defining Space



Xeric Planting



Rock Mulch at Foundation Wall

1. Develop, maintain and implement a climate-based plant list with landscape features using a regionally appropriate palette of materials to promote energy efficiency, preserve drainage patterns, inhibit erosion, improve air quality, lower maintenance and add beauty. Follow UFC 3-201-02 Landscape Architecture.
2. Landscaping is required for all newly developed sites and facilities; preserve existing native landscape where possible and avoid overplanting.
3. Concentrate landscaping in Facility Group 1 and along major thoroughfares and integrate these landscaped areas into the base's stormwater management plan. Refer to the Streetscape Envelope Standards in this IFS.
4. All Facility Group 1 and 4 sites shall be landscaped at their entire perimeter; limit formal planting arrangements to formal spaces typically associated with Group 1. Landscape public spaces near the main entrances of Group 1 facilities.
5. Facility Group 2 and 3 sites may have a native undisturbed landscape except at the main entrances of Group 2, which should be newly landscaped.
6. Facility plantings shall follow the Installation Facilities Standards (IFS) plant list, which is based on the specific microclimates created by the adjacent building: shadow areas, protected areas, zones adjacent to thermal mass, and availability of rainwater and/or grey water.
7. Provide open spaces as transitions between developed and native areas that promote quality of life and provide visual relief and allow walkable connections to the transportation system.

8. Return suitable areas to a natural state to minimize and, whenever possible, eliminate ground maintenance requirements; expand prairie areas where appropriate with native plants to eliminate mowing and maintenance requirements.
9. In tree clusters replace grass with naturalized shrub beds and leaf litter mulch to eliminate mowing requirements.
10. Use plantings in open spaces to reinforce the space as a visual asset.
11. Consider landscape windbreaks when suitable for the local climate.
12. Integrate security requirements into the landscape design. Coordinate the heights of trees and shrubs and note restrictions for plantings following UFC 4-010-01.
13. Berms may be used as an integral part of the overall landscape strategy for screening, security and/or visual interest.

C06.1.2. Xeriscape Design Principles

Applicable N/A Large graphics do not apply

Applicable N/A Select number of graphics / images (small: 250 px x 188 px) to insert 2

Image Tool 250 x 188



Xeric Planting at Intersection



Xeric Species and Organic Mulch

1. Apply xeriscape principles following UFC 3-201-02, Appendix B, and Air Force Corporate Facilities Standards.
2. Facility plantings are encouraged to use native plant species and to consider specific microclimates created by the adjacent building: shadow areas, protected areas, zones adjacent to thermal mass, and availability of rainwater and/or grey water.

C06.1.3. Minimizing Water Requirements

Applicable N/A Large graphics do not apply

Applicable N/A Select number of graphics / images (small: 250 px x 188 px) to insert 3

Image Tool 250 x 188



Limited Planting Areas



Xeric Planting



Drought Tolerant Grasses

1. Reasonably reduce demand on potable water while seeking opportunities to increase alternative water sources for irrigation. Reduce or eliminate the use of potable/domestic water for purposes of landscape architecture maintenance, consistent with legal or contractual obligations, and prohibit potable-water irrigation in new construction beyond establishment following current DoD and Air Force policy.

C06.1.4. Plant Material Selection

Applicable N/A Large graphics do not apply

Applicable N/A Select number of graphics / images (small: 250 px x 188 px) to insert 3

Image Tool 250 x 188



Native Ornamental Species



Indigenous Shrubs



Flowering Species

1. Use only native, naturally occurring plant materials including grasses or turf suited for the local climatic conditions in the landscape design; potable-water irrigation systems are discouraged beyond the establishment period.
2. New facilities are encouraged to use native plant species as indicated on the plant lists available from the Base Civil Engineer.
3. Trees should be the focus of landscape plantings and, where possible, should be a mix of deciduous and evergreen species for variety; provide tree grates when appropriate and use tree guards on smaller trees.
4. Ground covers are only recommended when minimal maintenance is required.

5. Turf areas should be limited to those that can be sustained by natural rainfall or grey water (non-potable) irrigation systems; turf may be defined by at-grade concrete mow strips to lessen maintenance.
6. Analyze soils and provide organic amendments as needed to improve plant growth and conserve water.
7. All plant material shall have one-year warranty and is subject to approval by the 765th ABS Engineering.

C06.1.5. Water Budgeting (Hydrozones)

Applicable N/A Large graphics do not apply

Applicable N/A Small graphics do not apply

1. Comply with DoD and Air Force policy on potable-water irrigation systems.
2. Provide irrigation systems in new construction to establish plant materials following “Water for Landscaping” in UFC 1-200-02. Note the climate zone and annual rainfall for the locale.
3. New buildings shall cost-effectively integrate a grey-water reclamation system following UFC 1-200-02, which provides source water for an automatic drip irrigation system; connect adaptive plantings adjacent to facilities to a grey-water irrigation system when available and discontinue the use of potable water for irrigation after the establishment period.
4. Provide irrigation design following UFC 3-201-02. Install drip irrigation products and components following UFGS Section 32 84 24 Irrigation Sprinkler Systems. Match the color of valve box lids to the adjacent ground treatment (i.e. green at turf & native seed areas, brown at wood mulch & rock areas).
5. Life cycle cost-effectively equip irrigation systems to sense soil moisture, rainfall and wind to minimize unnecessary watering; incorporate drip irrigation systems as the primary source.

C06.1.6. Base Entrance Landscaping

Applicable N/A Large graphics do not apply

Applicable N/A Select number of graphics / images (small: 250 px x 188 px) to insert 1

Image Tool 250 x 188



Preserved Sight Lines

1. At the main gate, reinforce a sense of arrival through a well-designed concentration of landscape elements consistent in visual quality with Facility Group 1.
2. Ensure landscaping has seasonal features with spring and fall color and a combination of evergreen and deciduous trees and shrubs for winter interest.
3. Integrate base signs and street and pedestrian lighting whenever feasible.

C06.1.7. Streetscape Landscaping

Applicable N/A Large graphics do not apply

Applicable N/A Select number of graphics / images (small: 250 px x 188 px) to insert 1

Image Tool 250 x 188



Street Trees Set Back from Roadway

1. Provide landscape designs with plant materials appropriately representing the level of quality of the adjacent Facility Group number. Refer to the Installation Elements section.
2. Select a variety of regionally appropriate streetscape plantings and grading to create a visual interest.

C06.1.8. Pedestrian Circulation Landscaping

Applicable N/A Large graphics do not apply

Applicable N/A Select number of graphics / images (small: 250 px x 188 px) to insert 1

Image Tool 250 x 188



Native Grasses and Groundcovers

1. Define walkways with landscaping where appropriate.
2. Provide rest areas along the pedestrian circulation network with human-scaled deciduous shade trees. Supplement tree plantings with finely textured shrubs when appropriate for the climate.
3. Provide wind breaks where required.

C06.1.9. Parking Lot Landscaping

Applicable N/A Large graphics do not apply

Applicable N/A Small graphics do not apply

1. Integrate appropriate landscaping elements into parking areas to visually soften the appearance at a minimum rate of 10 percent of the total area.
2. Avoid trees that drop sap, fruit, or seeds, and use long-lived species; keep trees trimmed, removing dead and dying trees or branches.
3. Provide planting in islands within parking lots for shade and appeal following IFS and the base stormwater management plan.
4. Rain garden islands shall be landscaped to receive rainwater runoff from adjacent impervious parking areas to be absorbed into the ground/planting bed. Native plants and groundcovers are recommended within the rain garden areas, which can survive without supplemental irrigation once established.

C06.1.10. Screen/Accent Landscaping

Applicable N/A Large graphics do not apply

Applicable N/A Select number of graphics / images (small: 250 px x 188 px) to insert 1

Image Tool 250 x 188



Tree Providing Screening and Shading

1. Provide complimentary accent landscaping at monuments and static displays.
2. At Facility Group 1, provide landscaping adjacent to all freestanding signs without distracting from the written communication.
3. Provide landscape screening of utility elements adjacent to Facility Group 1.
4. Providing landscaping as visual screening is preferred to the construction of walls and fences; berming and mounding may supplement landscape screening.

C06.1.11. Other

Applicable N/A Large graphics do not apply

Applicable N/A Small graphics do not apply

C07. SITE FURNISHINGS

Comply with AF Corporate Standards for Site Development:

<http://afcs.wbdg.org/site-development/index.html>

Comply with AF Corporate Standards for Site Furnishings:

<http://afcs.wbdg.org/site-development/site-furnishings/index.html>

C07.1. Furnishings and Elements

Applicable N/A Large graphics do not apply

Applicable N/A Select number of graphics / images (small: 250 px x 188 px) to insert 12

Image Tool 250 x 188



Azorean Stone Wall with Concrete Cap



Base Standard Dumpster Screens

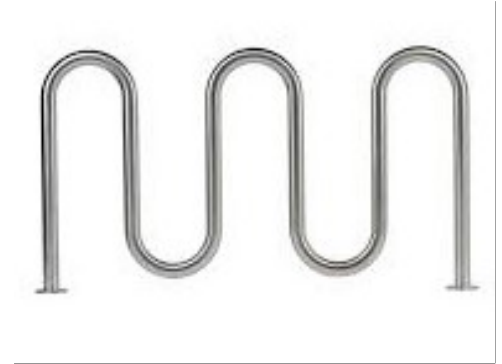

Bicycle Rack



Building Screen Walls



Concrete Bollards



EU Standard Yellow and Black Striped Bollards



Garbage Dumpsters



Smooth Aggregate Picnic Table



Smooth Aggregate Seating Bench



1. Provide a coordinated consistent inventory of site furnishings to positively contribute to the visual environment, image, and identity of the base; ensure durability, low maintenance, reduced visual clutter, and compatibility with the adjacent architecture.
2. Remove poorly located or redundant litter / ash receptacles, newspaper and bicycle racks, telephone booths, vending machines, walls and fences to reduce visual clutter and to lessen the requirements for maintenance.
3. Groups 1 to 4 site furnishings shall be architecturally compatible, able to withstand the extreme corrosive environment and must be approved by the 765th ABS Engineering. Generally match the site furniture of adjacent facilities and the facility district.
4. Install needed outdoor seating (benches and low walls) in public gathering spaces near main and secondary building entrances. Low walls shall match facility architecture.
5. Benches in all Groups and parks shall be light colored and manufactured from aggregate with a smooth finish or Recycled plastic or High-density polyethylene (HDPE) with a Cedar color.
6. Integrate functional bicycle racks with the design of the building's main entrance grounds in Facility Groups 1 and 2 while meeting ATFP requirements.
7. Limit the use of bollards, but when necessary for force protection pre-cast concrete bollards with a natural concrete finish in Groups 1 and 4, parks and trails, 200 mm (8 inches) steel bollards filled with concrete in Group 2 and 3. Illuminated bollards may be used as approved on a case basis. Stainless steel may be used in Group 1 when approved by the 765th ABS Engineering.
8. Locate architecturally coordinated containers for recycling, litter, ash, vending, etc., to minimize visual clutter and not be visible from the building's main entrance. Minimize the use of freestanding planters.
9. Generally limit picnic tables, barbeque grills and drinking fountains to lodging, dormitories, housing areas, parks and recreation areas following IFS.
10. The Installation Flagpole location shall comply with the guidance for the display of flags in AFI 34-1201. Each Air Force installation is authorized to fly one United States Flag, normally in front of the installation headquarters. Waivers for non-authorized locations must be submitted in accordance with AFI 33-360 and approved waivers (AF Form 679) must be maintained by the installation protocol office.
11. Refer to the Overview Section "Facility Hierarchy" topic of this AFCFS for guidelines regarding ancillary structures such as pavilions and shade shelters.
12. Bus shelters shall be provided only where there is a documented need and when approved on a case basis. Generally emulate the designs of adjacent shelters and able to withstand the extreme corrosive environment and must be approved by the 765th ABS Engineering.
13. Monuments and static displays shall be limited. New elements are generally discouraged unless these are fully vetted through the base's approval process and designed following IFS.

14. When visual screening is necessary, consider landscaping as the first option; screen walls are permitted only in Group 1 and shall be selected from the following types as shown:
 - Azorean stone wall with concrete cap. See Volume II, Section 2-8.5, Stone Walls for detailed information.
 - Azorean stone wall with a PVC screen fencing, similar to SCREENO WAVE or SCREENO LINE by BETAFENCE.
 - PVC screen fencing, similar to SCREENO WAVE or SCREENO LINE by BETAFENCE and concrete or CMU base and supports painted Cream Beige (RAL 1015).
15. For fencing, apply the standards for “Products, Materials and Color” in the following section. Limit those with the highest visual quality to Facility Group 1 where there is sustained maintenance. Define all levels of security and visual quality.
16. Do not use chain-link fencing at any Group (1 to 4) facilities; Limit the use of barbed-wire outriggers on chain-link fencing at industrial sites, unless required for additional security or protection of assets.
17. Provide trash dumpster enclosures for Group 1, 2 and 3 with Detached open terra-cotta clay units with a flower pattern or similar design that allows the appropriate airflow, but still visually screens the dumpster from view. Do not paint mortar joints. Utilize concrete bases and concrete vertical supports painted Cream Beige. Terra-cotta caps are utilized for detached screen walls. Enclosures should always be a minimum of **150 mm (6 inches)** taller than the dumpster being screened.
18. Specify screen wall materials and finishes that do not require painting or maintenance beyond periodic cleaning.
19. All Groups picnic tables and seating shall be one of the two types below:
 - Type 1 - shall be light colored and manufactured from aggregate with a smooth finish. These tables should match existing tables on base that are made from these materials.
 - Type 2 - Recycled plastic or High-density polyethylene (HDPE) with a Cedar color to match with trash receptacles and ash urns for seating and backrest and Sand-Cast Aluminum (Dark Bronze) or Stainless-steel (polished finish) for the frame.Generally limit picnic tables, barbeque grills and drinking fountains to lodging, dormitories, housing areas, parks and recreation areas.
20. Limit the use of freestanding planters to areas with ongoing maintenance.
21. Provide kiosks only where there is a documented need for visual communication of posted messages. When used, match adjacent facilities in materials and detailing and consolidate kiosks with other site furnishings within 30 feet of major pedestrian paths. Limit kiosks to facility Groups 1 and 2 and parks.
22. Manufacturers listed below are only provided to establish a baseline of equivalency among all applicable manufacturers.
23. See Appendix G for further information.

C07.2. Site Furnishings Products, Materials and Color

Note: *Apply the below base-wide standards for Site Furnishings (products, materials and color). Then refer to the Appendix and apply any additional requirements specifically related to the Facility District in which the project is located.*

C07.2.1. Barbeque Grills

Applicable N/A

Number of base standards 2

Image Tool 250 x 188



Type: **Charcoal**

Applies to: Group 1 Group 2 Group 3 Group 4 Other

Mfr: Most Dependable Fountains, Inc.

Color: Natural stainless steel

Finish: Mill

Model #: SS BBQ Grill

Other: Concrete foundation, coordinate with Base Architect

UFGS: N/A

Type: **Natural Gas**

Applies to: Group 1 Group 2 Group 3 Group 4 Other

Mfr: BBQ Coach

Color: Natural stainless steel

Finish: Mill

Model #: 32" 4-Burner

Other: Built-in Concrete or masonry, coordinate with Base Architect

UFGS: N/A



C07.2.2. Benches

Applicable N/A

Number of base standards 2

Image Tool 250 x 188



Type: **Aggregate**

Applies to: Group 1 Group 2 Group 3 Group 4 Other

Mfr: Local

Color: Light Colored

Finish: Smooth finish (similar to existent on base)

Model #: N/A

Other: Similar to existing

UFGS: N/A

Type: **Recycled plastic (RP) or High-density polyethylene (HDPE)**

Applies to: Group 1 Group 2 Group 3 Group 4 Other

Mfr: Various

Color: Cedar

Finish: Factory

Model #: N/A

Other: RP or HDPE seating and backrest with Sand-Cast Aluminum (Dark Bronze) or Stainless-steel (polished finish) frame. All fasteners shall be Stainless-steel 316L and all benches shall have armrests and backrest.

UFGS: N/A



C07.2.3. Bike Racks

Applicable N/A

Number of base standards 5

Image Tool 250 x 188

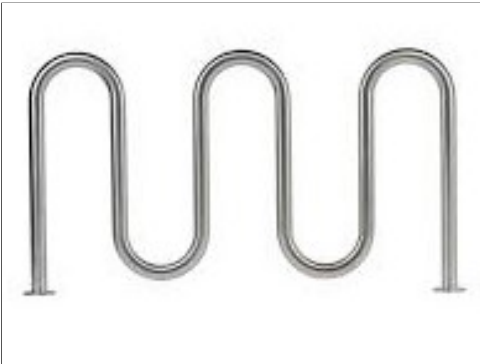

Type: **Multiple bike rack**

Applies to: Group 1 Group 2 Group 3 Group 4 Other

Mfr: Local

Color: Polished stainless steel 316L

Finish: Factory

Model #: Wave shaped rack

Other: All fasteners and accessories shall be Stainless Steel 316L. Surface mount (concrete anchors through discs welded to legs)

UFGS: N/A

Type: **Multiple bike rack - Details Front View**

Applies to: Group 1 Group 2 Group 3 Group 4 Other

Mfr: Local

Color: Polished stainless steel 316L

Finish: Factory

Model #: Wave shaped rack

Other: All fasteners and accessories shall be Stainless Steel 316L. Surface mount (concrete anchors through discs welded to legs)

UFGS: N/A

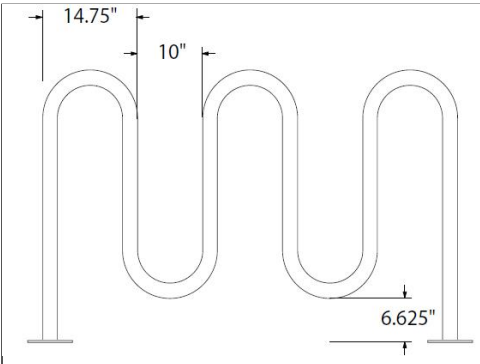

Type: **Multiple bike rack - Details Side View**

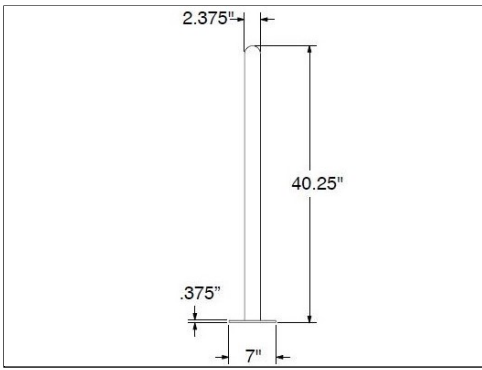

Applies to: Group 1 Group 2 Group 3 Group 4 Other

Mfr: Local

Color: Polished stainless steel 316L

Finish: Factory

Model #: Wave shaped rack

Other: All fasteners and accessories shall be Stainless Steel 316L. Surface mount (concrete anchors through discs welded to legs)

UFGS: N/A

Type: **Multiple bike rack - Details Top View**

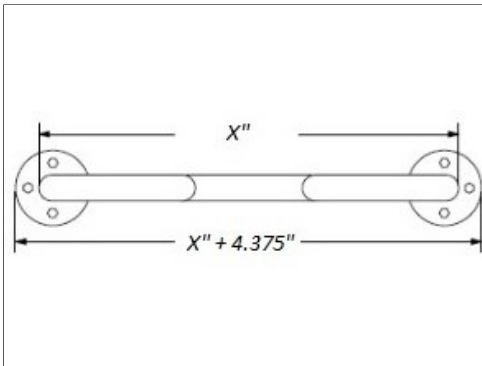

Applies to: Group 1 Group 2 Group 3 Group 4 Other

Mfr: Local

Color: Polished stainless steel 316L

Finish: Factory

Model #: Wave shaped rack

Other: All fasteners and accessories shall be Stainless Steel 316L. Surface mount (concrete anchors through discs welded to legs)

UFGS: N/A

Type: **Multiple bike rack - Details Base Plate**

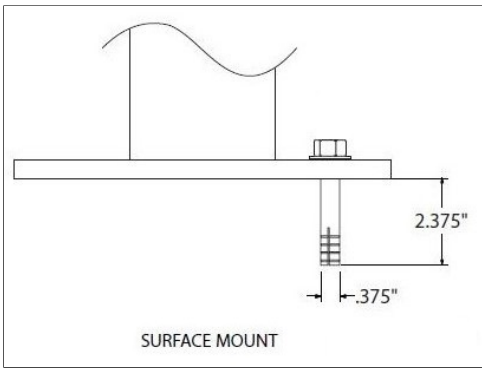

Applies to: Group 1 Group 2 Group 3 Group 4 Other

Mfr: Local

Color: Polished stainless steel 316L

Finish: Factory

Model #: Wave shaped rack

Other: All fasteners and accessories shall be Stainless Steel 316L. Surface mount (concrete anchors through discs welded to legs)

UFGS:

C07.2.4. Bike Lockers

Applicable N/A

C07.2.5. Bollards

Applicable N/A

Number of base standards 4

Image Tool 250 x 188



Type: **Precast concrete bollards**

Applies to: Group 1 Group 2 Group 3 Group 4 Other

Mfr: Local

Color: Grey (Concrete)

Finish: Textured

Model #: Cylinder shaped

Other: N/A

UFGS: N/A



Type: **Concrete filled pipe**

Applies to: Group 1 Group 2 Group 3 Group 4 Other

Mfr: Local

Color: EU Standard Striped Yellow and Black

Finish: Factory

Model #: 200 mm (8 inches) concrete filled pipe

Other: N/A

UFGS: N/A

Type: **Concrete filled pipe - Detail**

Applies to: Group 1 Group 2 Group 3 Group 4 Other

Mfr: Concrete filled pipe

Color: EU Standard Striped Yellow and Black

Finish: Factory

Model #: 200 mm (8 inches) concrete filled pipe

Other: N/A

UFGS: N/A

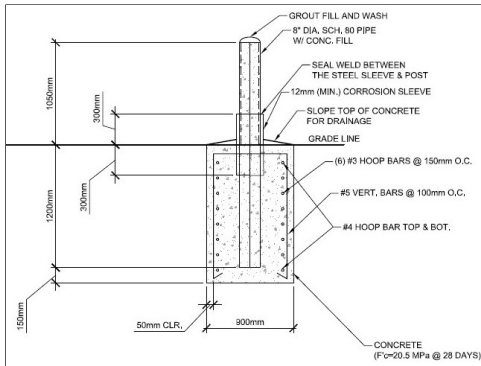



Type: **Lockable Removable Bollards**

Applies to: Group 1 Group 2 Group 3 Group 4 Other

Mfr: Local

Color: Dark bronze or stainless steel

Finish: Factory

Model #: N/A

Other: Welded handles to facilitate moving the bollard

UFGS: N/A

C07.2.6. Bus Shelters

Applicable N/A

C07.2.7. Drinking Fountains

Applicable N/A Number of base standards 1

Image Tool 250 x 188



Type: **Pedestal**

Applies to: Group 1 Group 2 Group 3 Group 4 Other

Mfr: Most Dependable Fountains, Inc.

Color: Natural

Finish: Stainless Steel

Model #: MDF 440 SMSS

Other: Accessible

UFGS: N/A

C07.2.8. Dumpster Enclosures / Gates

Applicable N/A

Number of base standards 1

Image Tool 250 x 188



Type: **Open Terra-cotta clay units with a flower pattern (or similar design)**

Applies to: Group 1 Group 2 Group 3 Group 4 Other

Mfr: Local

Color: Terra-Cotta

Finish: Open terra-cotta clay units with a flower pattern with Terra-cotta caps.

Model #: Flower pattern

Other: The height of screen walls shall be a minimum of 150 mm (6 inches) taller than the dumpster. Don't paint mortar joints. Utilize concrete bases and concrete vertical supports painted Cream Beige.

UFGS: Section 04 20 00 Unit Masonry

C07.2.9. Fencing

Applicable N/A

Number of base standards 9

Image Tool 250 x 188

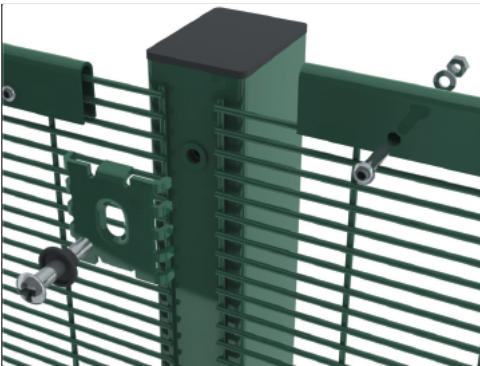

Type: **High security Fence - Base Perimeter and Controlled Area Fencing**

Applies to: Group 1 Group 2 Group 3 Group 4 Other

Mfr: Betafence

Color: Green - RAL 6005

Finish: Zinc-aluminum alloy and marine grade polyester coating

Model #: Securifor 2D

Other: N/A

UFGS: Section 05 50 13 Miscellaneous Metal Fabrications

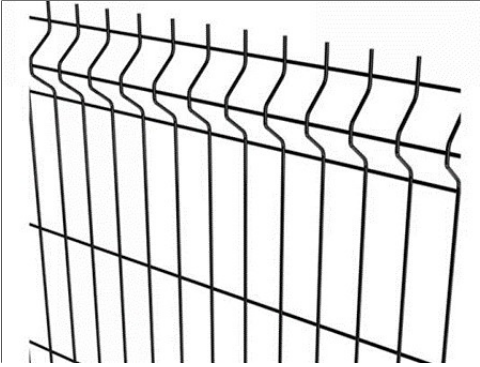

Type: **Medium security - Residential, boundary and general security**

Applies to: Group 1 Group 2 Group 3 Group 4 Other

Mfr: Betafence

Color: Green - RAL 6005

Finish: Zinc-aluminum alloy and marine grade polyester coating

Model #: Securifor 3D

Other: N/A

UFGS: Section 05 50 13 Miscellaneous Metal Fabrications



Type: **Recreational Fencing**

Applies to: Group 1 Group 2 Group 3 Group 4 Other

Mfr: Betafence

Color: Green - RAL 6005

Finish: Zinc-aluminum alloy and marine grade polyester coating

Model #: Bekasport system with Nylofor 2D Super panels

Other: N/A

UFGS: Section 05 50 13 Miscellaneous Metal Fabrications

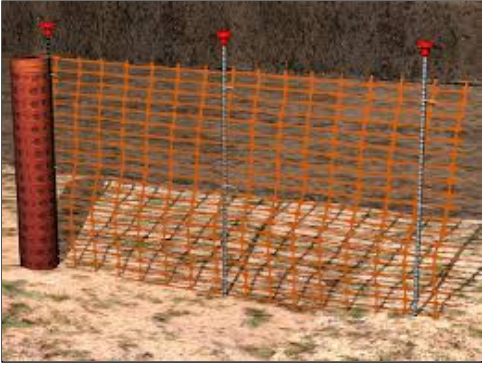

Type: **Construction Fencing - Type 1**

Applies to: Group 1 Group 2 Group 3 Group 4 Other

Mfr: Various

Color: Orange

Finish: N/A

Model #: Orange Safety Barrier Mesh, Safety rebar caps and #6 rebar

Other: Will be used for projects of 30 days or less in duration unless dictated by the contracting officer (CO). The fence will always be kept in good repair and replaced if requested by the CO.

UFGS: N/A

Type: **Construction Fencing - Style 2**

Applies to: Group 1 Group 2 Group 3 Group 4 Other

Mfr: Various

Color: N/A

Finish: N/A

Model #: Construction fence, Concrete block and Bracing

Other: Will be used for all projects in duration of more than 30 days or if its use is dictated by the CO. This fence shall be galvanized wire frame and 1.8 m (6 feet) high.

UFGS: Section 05 50 13 Misc. Metal

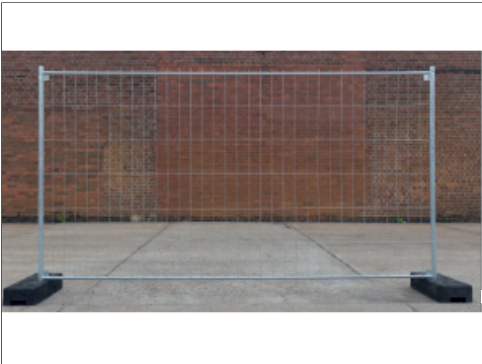

Type: **Construction Fencing - Style 3**

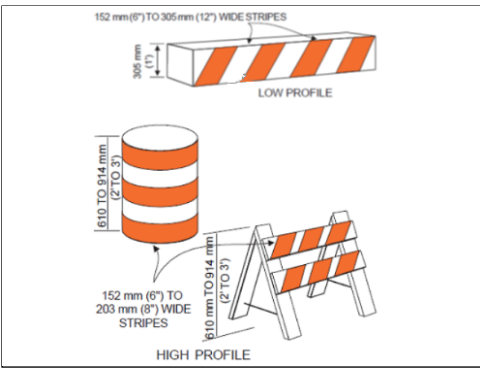

Applies to: Group 1 Group 2 Group 3 Group 4 Other

Mfr: Various

Color: N/A

Finish: N/A

Model #: N/A

Other: Used for all projects that, require additional perimeter protection or where pavement markings do not provide adequate definitions of closed or hazardous areas or if its use is dictated by the CO.

UFGS: N/A

Type: **Sliding Gates – Style 1**



Applies to: Group 1 Group 2 Group 3 Group 4 Other

Mfr: Betafence

Color: Green - RAL 6005

Finish: Zinc-aluminum alloy and marine grade polyester coating

Model #: Robusta SC

Other: Sliding gates shall utilize 40 mm (1.5 in.) security topping to help prevent intruders. Lock System must be compatible with Best Cores utilized on base.

UFGS: Section 05 50 13 Miscellaneous Metal Fabrications

Type: **Sliding Gates – Style 2**



Applies to: Group 1 Group 2 Group 3 Group 4 Other

Mfr: Betafence

Color: Green - RAL 6005

Finish: Zinc-aluminum alloy and marine grade polyester coating

Model #: Blokad Sliding Gate (Motorized)

Other: For areas that require additional protection against hostile vehicle attacks. Compliant with PAS 68 standard. Lock System (Key Switch) must be compatible with Best Cores utilized on base.

UFGS: Section 05 50 13 Miscellaneous Metal Fabrications

Type: **Swinging Gates (Single or Double)**



Applies to: Group 1 Group 2 Group 3 Group 4 Other

Mfr: Betafence

Color: Green - RAL 6005

Finish: Zinc-aluminum alloy and marine grade polyester coating

Model #: Securifor Gate

Other: Swinging gates should also utilize 40 mm (1.5 in.) security topping to help prevent intruders. Lock System must be compatible with Best Cores utilized on base

UFGS: Section 05 50 13 Miscellaneous Metal Fabrications

C07.2.10. Flagpoles

Applicable N/A

Number of base standards 1

Image Tool 250 x 188



Type: **Flagpole**

Applies to: Group 1 Group 2 Group 3 Group 4 Other

Mfr: Eder Flag

Color: Natural aluminum

Finish: Satin Lustre

Model #: ECL30 IH, Internal Halyard

Other: 5" Butt Dia. 33' H (30' Exposed)

UFGS: N/A

C07.2.11. Lighting – Landscape / Accent

Please refer to the Lighting section.

C07.2.12. Litter and Ash Receptacles

Applicable N/A

Number of base standards 5

Image Tool 250 x 188



Type: **Litter Receptacles**

Applies to: Group 1 Group 2 Group 3 Group 4 Other

Mfr: Various

Color: Cedar

Finish: High-density polyethylene recycled plastic boards

Model #: Round and with the capacity for at least 22 gallons

Other: Shall be Base Plate Mount and all metal components shall be stainless steel or aluminum.

UFGS: N/A



Type: **Litter and Ash Receptacles**

Applies to: Group 1 Group 2 Group 3 Group 4 Other

Mfr: Various

Color: Cedar and Black top

Finish: High-density polyethylene recycled plastic boards

Model #: Round and with the capacity for at least 22 gallons

Other: All metal components shall be stainless steel or aluminum.

UFGS: N/A



Type: **Ash Receptacles – Style 1**

Applies to: Group 1 Group 2 Group 3 Group 4 Other

Mfr: Various

Color: Cedar and Black top

Finish: High-density polyethylene recycled plastic boards

Model #: Round and with the capacity for at least 22 gallons

Other: All metal components shall be stainless steel or aluminum.

UFGS: N/A



Type: **Ash Receptacles– Style 2**

Applies to: Group 1 Group 2 Group 3 Group 4 Other

Mfr: Various

Color: Dark Bronze

Finish: High-density polyethylene recycled plastic

Model #: N/A

Other: N/A

UFGS: N/A



Type: **Recycling Bins**

Applies to: Group 1 Group 2 Group 3 Group 4 Other

Mfr: Various

Color: Natural

Finish: Polished or Lightly Brushed Stainless Steel

Model #: N/A

Other: 4 separate compartments

UFGS: N/A

C07.2.13. Picnic Tables

Applicable N/A

Number of base standards 2

Image Tool 250 x 188



Type: **Smooth Aggregate Picnic Table – Type 1**

Applies to: Group 1 Group 2 Group 3 Group 4 Other

Mfr: Various

Color: Light beige

Finish: Standard smooth finish

Model #: Oval, surface mount

Other: Shall be light colored and manufactured from aggregate with a smooth finish. Tables should match existing tables on base that are made from these materials.

UFGS: N/A

Type: **Recycled plastic or High-density polyethylene Picnic Table – Type 2**

Applies to: Group 1 Group 2 Group 3 Group 4 Other

Mfr: Various

Color: Cedar or as approved

Finish: Standard finish

Model #: Rectangular

Other: RP or HHDPE with a Cedar color seating and table. Structure shall be Sand-Cast Aluminum (Dark Bronze) or Stainless-steel (polished finish) for the frame with base plate for surface mount. All fasteners shall be SS

UFGS: N/A

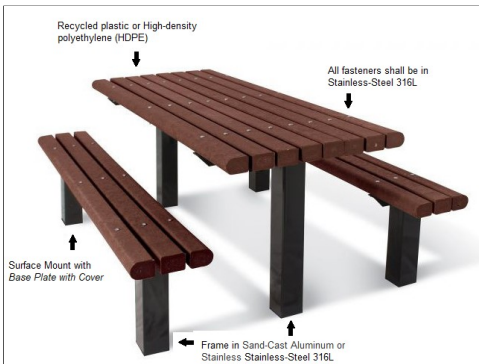

C07.2.14. Planters

Applicable N/A

Number of base standards 1

Image Tool 250 x 188

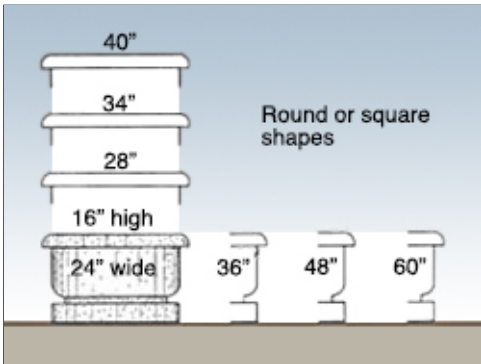

Type: **Precast concrete**

Applies to: Group 1 Group 2 Group 3 Group 4 Other

Mfr: Materials, Inc.

Color: Weatherstone Gray

Finish: Smooth

Model #: Santa Fe

Other: N/A

UFGS: N/A

C07.2.15. Play Equipment

Applicable N/A

Number of base standards 1

Image Tool 250 x 188



Type: **Steel**

Applies to: Group 1 Group 2 Group 3 Group 4 Other

Mfr: Little Tikes Commercial

Color: Varies

Finish: Powdercoated Steel

Model #: N-R-G Freestyle

Other: Coordinate with 765th Engineering Section

UFGS: N/A

C07.2.16. Screen Walls

Applicable N/A

Number of base standards 5

Image Tool 250 x 188



Type: **Building Screen Walls**

Applies to: Group 1 Group 2 Group 3 Group 4 Other

Mfr: Custom

Color: Terracotta, Cream Beige RAL 1015

Finish: Natural

Model #: Flower pattern, similar to existing

Other: Screen walls attached to buildings should be utilized to screen HVAC, electrical and other equipment from view. Screens should always be a minimum of 150 mm (6 inches) taller than the equipment

UFGS: N/A

Type: **Detached Screen Walls**

Applies to: Group 1 Group 2 Group 3 Group 4 Other

Mfr: Custom

Color: Terracotta, Cream Beige RAL 1015

Finish: Natural

Model #: Flower pattern, similar to existing

Other: Equipment that is detached from buildings should be screened with three-sided, masonry enclosures design to hide the equipment from view as much as possible.

UFGS: N/A



Type: **Stone Walls**

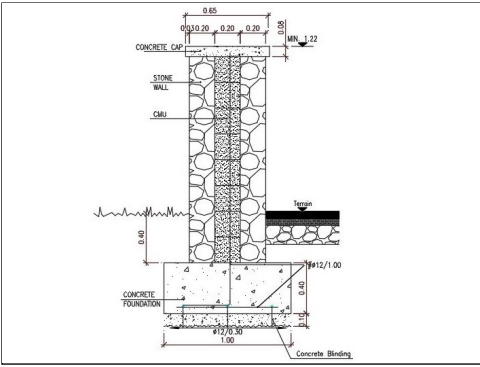

Applies to: Group 1 Group 2 Group 3 Group 4 Other

Mfr: Local

Color: Natural

Finish: Natural

Model #: CMU core with stone finish and concrete cap

Other: The stone veneer is secured in place with a Sika MonoTop-612 and admixture such as Sikalatex or equivalent. Apply Hydro-repellent paint "Weber Klinor Hydrofuge B" or equivalent on cap.

UFGS: Section 04 20 00 Unit Masonry

Type: **Screen - Type 1**



Applies to: Group 1 Group 2 Group 3 Group 4 Other

Mfr: Betafence

Color: Green or approved by 765th Engineering

Finish: Factory

Model #: Screeno Line with Concrete Base

Other: N/A

UFGS: N/A



Type: **Screen - Type 1**

Applies to: Group 1 Group 2 Group 3 Group 4 Other

Mfr: Betafence

Color: Green or approved by 765th Engineering

Finish: Factory

Model #: Screeno Wave with Concrete Base

Other: N/A

UFGS: N/A

C07.2.17. Tree Grates

Applicable N/A

Number of base standards 1

Image Tool 250 x 188



Type: **Cast Iron**

Applies to: Group 1 Group 2 Group 3 Group 4 Other

Mfr: Neenah Enterprises, Inc.

Color: Natural cast iron

Finish: Cast

Model #: 2-Piece, round or square

Other: N/A

UFGS: N/A

C07.2.18. Other

Applicable N/A

Number of base standards 1

Image Tool 250 x 188



Type: **Garbage Dumpsters**

Applies to: Group 1 Group 2 Group 3 Group 4 Other

Mfr: Various

Color: Green

Finish: Standard

Model #: Similar to existing

Other: Garbage dumpsters should be manufactured utilizing high-density polyethylene plastic with a green color that is inherent to the plastic material to avoid the need for painting and SS casters with wheels

UFGS:

C08. EXTERIOR SIGNS

Comply with AF Corporate Standards for Site Development:

<http://afcs.wbdg.org/site-development/index.html>

Comply with AF Corporate Standards for Exterior Signs:

<http://afcs.wbdg.org/site-development/exterior-signs/index.html>

C08.1. Colors and Types

Applicable N/A Large graphics do not apply

Applicable N/A Small graphics do not apply

1. Provide concise functional signs as a visually unifying element with consistent colors and types for all Installation and Gate Identification Signs; Building Identification Signs; Traffic Control Devices; Directional and Wayfinding Signs; and Informational and Motivational Signs.
2. Provide signs with the lowest overall life-cycle costs considering initial cost, ongoing maintenance and lifespan while meeting quality standards. Follow IFS for specifications appropriate for the local climate to withstand weathering.
3. Reduce the number of signs, reduce visual clutter and provide only essential signs required for identification, directions, instructions, and customer service following UFC 3-120-01. Remove non-conforming signs during renovation projects.
4. Use clear concise terms for content consistent with UFC 3-120-01.
5. Display of emblems on building exterior walls or other permanent structures is prohibited by UFC.
6. Raised "standout" letters and numbers may be used for Group 1 with approval on a case basis.
7. Group 2 and 3 facilities shall have wall mounted facility signs with sizes and layouts following UFC 3-120-01.

8. Only one identification sign is permitted at each building entrance. Include a building address consistent with US Postal Service protocols following UFC 3-120-01.
9. Traffic Control Devices, which regulate vehicular traffic on the installation, shall conform to the standards in "Disposicoes Normativas" of "Instituto de Infra-Estruturas Rodoviaras". Coordinate street signs with this IFS.
10. Provide Directional and Wayfinding Signs and address both pedestrian and vehicular traffic following UFC 3-120-01 for size, layout and content.
11. Reserved parking signs should be kept to a minimum. When approved, provide post-mounted sign faces in base standard materials and colors. Consider "bracketing" a designated area with a single sign at each end.
12. Parking lot identification signs may be used to identify areas or rows within large lots.
13. Follow the guidelines and requirements in ABAAS and the in "Disposicoes Normativas" of "Instituto de Infra-Estruturas Rodoviaras" for accessible parking signs.
14. Follow UFC 3-120-01 for Informational and Motivational Signs for size, layout and content.
15. Symbols or pictographs (graphic expressions of objects) may be used to indicate service, mandatory / prohibitory, sports, and recreation when rapid communication is necessary.
16. Force Protection signage may be applied to glass doors using white vinyl lettering.
17. Refer to UFC 3-120-01 for prohibited signs, which include those with animated, blinking, chasing, flashing, or moving effects.
18. Manufacturers listed below are only provided to establish a baseline of equivalency among all applicable manufacturers.
19. Location and content of all exterior signs shall be subject to approval by HAAZ and the 765th ABS.

C08.1.1. Materials and Color Specifications

Applicable N/A Large graphics do not apply

Applicable N/A Small graphics do not apply

1. Fabricate sign panels from aluminum flat sheet. Sign posts shall be extruded aluminum with capped ends and attached to the concrete foundation.
2. Fence mounted sign panels may be attached with exposed fasteners.

Materials and Color Specifications

Applicable N/A

Number of base standards 3

Image Tool 250 x 188

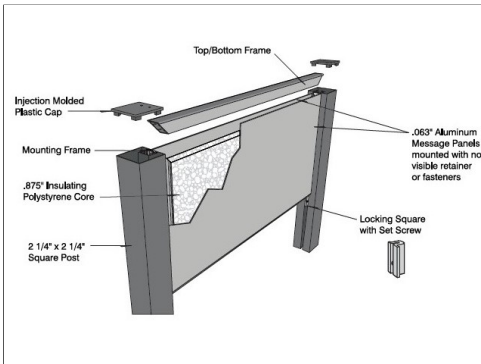

Type: **Typical Sign**

Applies to: Group 1 Group 2 Group 3 Group 4 Other

Mfr: Howard Industries

Color: Medium bronze

Finish: Matte vinyl

Model #: Aluminum flat sheet

Other: Cabinet style frame that attaches two panels with no visible retainers and no exposed fasteners for a frameless appearance. Mount to square posts. Provide sizes following UFC.

UFGS: Section 05 50 13 Miscellaneous Metal Fabrications

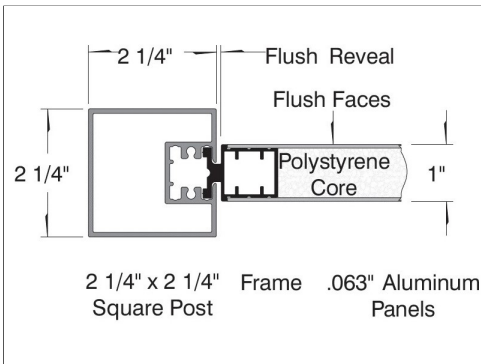

Type: **Typical Sign Post**

Applies to: Group 1 Group 2 Group 3 Group 4 Other

Mfr: Howard Industries

Color: Dark Bronze

Finish: Factory, Mate

Model #: Extruded aluminum with capped top ends

Other: Support posts should be at least 57 mm (2 1/4 in.) square extruded aluminum posts with base plate bolted to a concrete foundation, finishing with a cover the plate.

UFGS: Section 05 50 13 Miscellaneous Metal Fabrications

Type: **Typical Sign Base**

Applies to: Group 1 Group 2 Group 3 Group 4 Other

Mfr: Howard Industries

Color: Dark Bronze

Finish: Factory, Mate

Model #: Base Plate with Cover

Other: Comply with manufactures recommendations

UFGS: UFGS 03 30 00 Cast-in-place Concrete

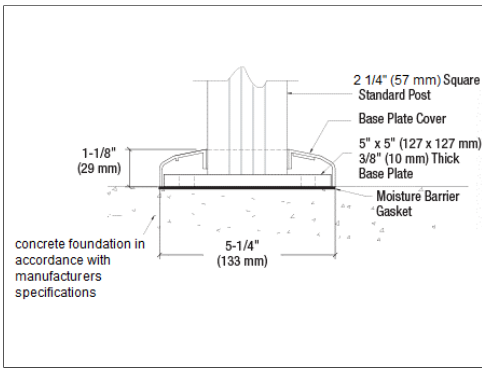

C08.1.2. Installation and Gate Identification Signs

Applicable N/A Number of base standards 1

Image Tool 250 x 188

Type: **Primary, Secondary and Tertiary (Uses per UFC)**

Applies to: Group 1 Group 2 Group 3 Group 4 Other

Mfr: Custom

Color: Dark bronze, brushed aluminum, accents per UFC

Finish: Powder coat or vinyl sign face

Model #: Metal frame and panels, buff stone base

Other: White vinyl lettering. Provide dimensions per UFC. Secondary signs shall match primary sign's materials, but shall be smaller in size per UFC. Tertiary signs shall follow the UFC.

UFGS: Section 05 50 13 Miscellaneous Metal Fabrications



C08.1.3. Building Identification Signs

Applicable N/A

Number of base standards 5

Image Tool 250 x 188



Type: **Freestanding Primary Sign (Sizes and Uses per UFC)**

Applies to: Group 1 Group 2 Group 3 Group 4 Other

Mfr: Howard Industries

Color: Medium brown face, dark bronze posts, white vinyl lettering

Finish: Powder coat or vinyl sign face

Model #: Aluminum sheet face, extruded aluminum posts

Other: Provide layout and sizes per UFC.

UFGS: Section 05 50 13 Miscellaneous Metal Fabrications

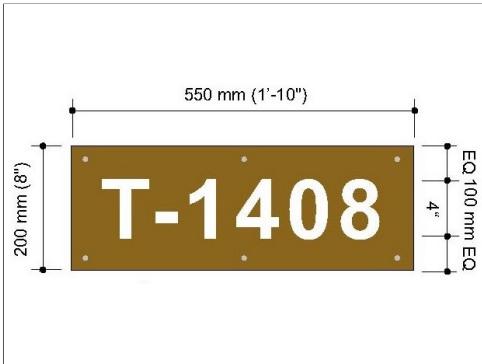

Type: **Wall Mounted - Main Base Facility Numbers**

Applies to: Group 1 Group 2 Group 3 Group 4 Other

Mfr: AMAN

Color: Medium brown face, white vinyl lettering

Finish: Satin vinyl applied to aluminum sheet

Model #: 2 mm thick, 200 mm tall and 550 mm wide with 100 mm tall letters

Other: Letters and facility numbers shall utilize 3M Scotchcal white vinyl. Attached with stainless steel fasteners with 3 mm noncorrosive spacers. Placed at corners 1500 mm to the bottom and 300 mm from the side.

UFGS: Section 05 50 13 Miscellaneous Metal Fabrications

Type: **Wall Mounted - Main Base Facility Numbers – Special sized**

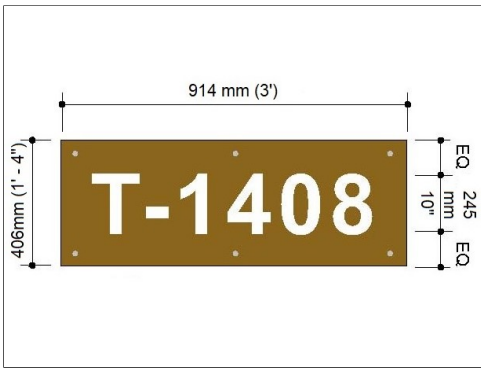

Applies to: Group 1 Group 2 Group 3 Group 4 Other

Mfr: AMAN

Color: Medium brown face, white vinyl lettering

Finish: Satin vinyl applied to aluminum sheet

Model #: 2 mm thick, 406 mm tall and 914 mm wide with 245 mm tall letters

Other: Special sized signs may be needed based on viewing distance and facility size. Type of lettering and fixation similar to previous.

UFGS: Section 05 50 13 Miscellaneous Metal Fabrications

Type: **Wall Mounted - Structures and Other Assets**

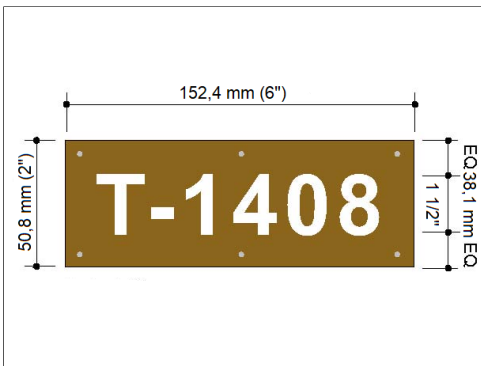

Applies to: Group 1 Group 2 Group 3 Group 4 Other

Mfr: AMAN

Color: Medium brown face, white vinyl lettering

Finish: Satin vinyl applied to aluminum sheet

Model #: 2 mm thick, 50,8 mm tall and 152,4 mm wide with 38,1 mm tall letters

Other: Signs to be attached to structures and other assets utilizing stainless steel mechanical with 3 mm (.125 inch) noncorrosive spacers to space signs off the wall.

UFGS: Section 05 50 13 Miscellaneous Metal Fabrications

Type: **Glass Mounted**



Applies to: Group 1 Group 2 Group 3 Group 4 Other

Mfr: Custom

Color: White vinyl lettering

Finish: Matte vinyl

Model #: Machine-cut sheet vinyl

Other: Apply vinyl lettering to glass. Provide sizes following UFC.

UFGS: N/A

C08.1.4. Traffic Control Devices (Street Signs)

Applicable N/A Number of base standards 5

Image Tool 250 x 188



Type: **Vehicular Regulatory Signs - Warning Danger**

Applies to: Group 1 Group 2 Group 3 Group 4 Other

Mfr: Sinalux

Color: Portuguese and EU standards

Finish: Highly reflective aluminum

Model #: Aluminum sign face and pole mounted 2.20 meters high

Other: Face shall be aluminum with a reflective background coating according to the EU vehicle regulatory standards. Fasteners shall be SS. Posts shall be galvanized steel or SS. Refer to Portuguese and EU standards.

UFGS: Section 05 50 13 Miscellaneous Metal Fabrications

Type: **Vehicular Regulatory Signs – Priority**

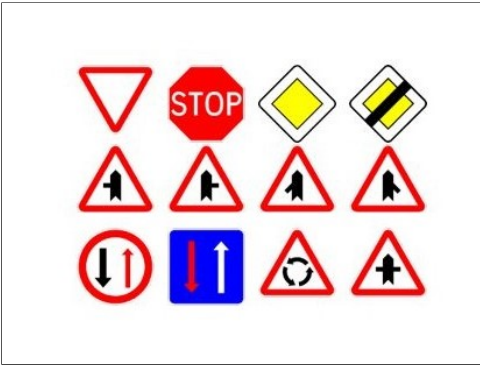

Applies to: Group 1 Group 2 Group 3 Group 4 Other

Mfr: Sinalux

Color: Portuguese and EU standards

Finish: Highly reflective aluminum

Model #: Aluminum sign face and pole mounted 2.20 meters high

Other: Face shall be aluminum with a reflective background coating according to the EU vehicle regulatory standards. Fasteners shall be SS. Posts shall be galvanized steel or SS. Refer to Portuguese and EU standards.

UFGS: Section 05 50 13 Miscellaneous Metal Fabrications

Type: **Vehicular Regulatory Signs - Prohibitory traffic**



Applies to: Group 1 Group 2 Group 3 Group 4 Other

Mfr: Sinalux

Color: Portuguese and EU standards

Finish: Highly reflective aluminum

Model #: Aluminum sign face and pole mounted 2.20 meters high

Other: Face shall be aluminum with a reflective background coating according to the EU vehicle regulatory standards. Fasteners shall be SS. Posts shall be galvanized steel or SS. Refer to Portuguese and EU standards.

UFGS: Section 05 50 13 Miscellaneous Metal Fabrications

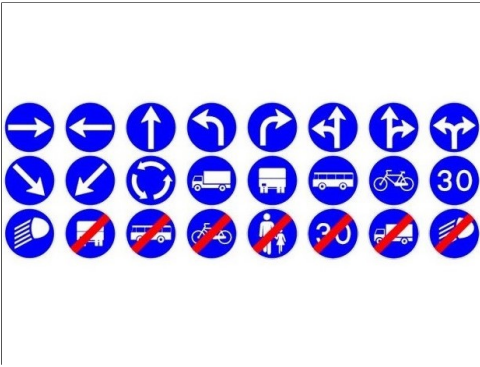

Type: **Vehicular Regulatory Signs - Mandatory**

Applies to: Group 1 Group 2 Group 3 Group 4 Other

Mfr: Sinalux

Color: Portuguese and EU standards

Finish: Highly reflective aluminum

Model #: Aluminum sign face and pole mounted 2.20 meters high

Other: Face shall be aluminum with a reflective background coating according to the EU vehicle regulatory standards. Fasteners shall be SS. Posts shall be galvanized steel or SS. Refer to Portuguese and EU standards.

UFGS: Section 05 50 13 Miscellaneous Metal Fabrications

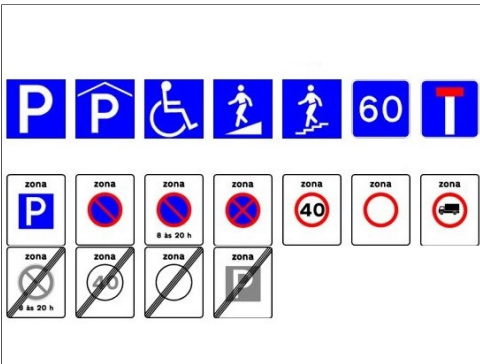

Type: **Vehicular Regulatory Signs - Informational and Specific Area Zone**

Applies to: Group 1 Group 2 Group 3 Group 4 Other

Mfr: Sinalux

Color: Portuguese and EU standards

Finish: Highly reflective aluminum

Model #: Aluminum sign face and pole mounted 2.20 meters high

Other: Face shall be aluminum with a reflective background coating according to the EU vehicle regulatory standards. Fasteners shall be SS. Posts shall be galvanized steel or SS. Refer to Portuguese and EU standards.

UFGS: Section 05 50 13 Miscellaneous Metal Fabrications

C08.1.5. Directional and Wayfinding Signs

Applicable N/A

Number of base standards 2

Image Tool 250 x 188



Type: **Vehicular**

Applies to: Group 1 Group 2 Group 3 Group 4 Other

Mfr: Custom

Color: Medium brown face, dark bronze posts, white reflective lettering

Finish: Powder coat or vinyl sign face

Model #: Aluminum sheet face, extruded aluminum posts

Other: Conform to the requirements of the MUTCD and its DoD Supplement. Provide types and sizes where required by UFC.

UFGS: Section 05 50 13 Miscellaneous Metal Fabrications

Type: **Pedestrian**

Applies to: Group 1 Group 2 Group 3 Group 4 Other

Mfr: Custom

Color: Medium brown face, dark bronze posts

Finish: Powder coat or vinyl sign face

Model #: Aluminum sheet face, extruded aluminum posts

Other: White vinyl lettering. Provide types and sizes where required by UFC.

UFGS: Section 05 50 13 Miscellaneous Metal Fabrications

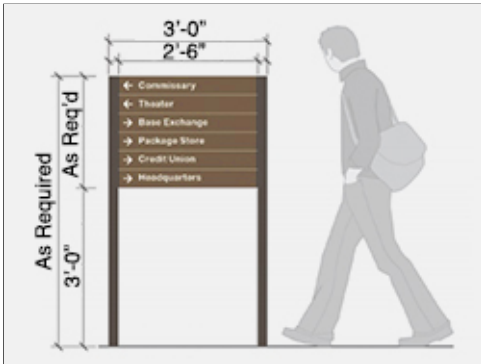

C08.1.6. Informational Signs

Applicable N/A Large graphics do not apply

Applicable N/A Select number of graphics / images (small: 250 px x 188 px) to insert 3

Image Tool 250 x 188



Construction Project Signs



Other Informational Sign



Marquee Signs

1. Minimize informational signs such as static display signs, hours of operation, and project signs to reduce visual clutter.
2. Static display signs shall have standard blue background.
3. Hours of operation signs shall have a level of quality equivalent to the Facility Group number.
4. Temporary / Project Signage shall be utilized as temporary signs that provide information regarding construction projects with performance periods of 120 days or more and shall be judiciously placed to avoid visual clutter. Schedule and arrange for the removal of these signs prior to installation.
5. Temporary / Project Signage shall be adhesive vinyl with Sudan Brown color and white lettering and must be submitted to 765 ABS for review and approval prior to installation.
6. All Marquee Signs signs shall be installed to ensure readers clearly understand the information presented without adversely impacting traffic flow and safety. Electronic signs will only be installed at the Main Gate and along the flightline in order to welcome distinguished visitors. The use of neon signs is prohibited.

C08.1.7. Motivational Signage

Applicable N/A Large graphics do not apply

Applicable N/A Small graphics do not apply

1. Provide professionally produced motivational signs as important elements of campaigns to boost morale, improve safety, aid in recruiting, and accomplish other motivational objectives. Consolidate this signage to reduce visual clutter.
2. Motivational signs shall be limited to an electronic "marquee" type changeable sign near each gate. Temporary signs are not permitted. Motivational information may also be posted in a small, printed format on kiosks in specified, high pedestrian use areas. Refer to kiosks under Site Furnishings.
3. Follow UFC 3-120-01 for color and layout. Note that animated, blinking, chasing, flashing, or moving effects are prohibited by the UFC.
4. Mount marquee signs on reinforced concrete bases with a natural warm gray color.

C08.1.8. Parking Lot Signs

Applicable N/A

Number of base standards 4

Image Tool 250 x 188



Type: **Reserved Parking Signs**

Applies to: Group 1 Group 2 Group 3 Group 4 Other

Mfr: AMAN

Color: 56 String Brown (National Park Service Brown)

Finish: Satin vinyl applied to aluminum sheet

Model #: 2 mm thick, 125 mm tall, 500 mm wide with 55 mm tall letters.

Other: Signs shall be attached to curbs or wheel stops utilizing stainless steel mechanical fasteners as required by the curb conditions. Signs to be placed at the center of the parking space to be reserved, where possible

UFGS: Section 05 50 13 Miscellaneous Metal Fabrications



Type: **Parking Prohibited Signs**

Applies to: Group 1 Group 2 Group 3 Group 4 Other

Mfr: Sinalux

Color: Blue, Red and White

Finish: Highly reflective aluminum

Model #: P 44 07 or P 44 10, Aluminum sign face and pole mounted 2.20 m high

Other: Face shall be aluminum with a reflective background coating according to the EU vehicle regulatory standards. Fasteners shall be SS. Posts shall be galvanized steel or SS. Refer to Portuguese and EU standards.

UFGS: Section 05 50 13 Miscellaneous Metal Fabrications



Type: **Parking Lot Identification Signs**

Applies to: Group 1 Group 2 Group 3 Group 4 Other

Mfr: Sinalux

Color: Blue and White

Finish: Highly reflective aluminum

Model #: P 45 74

Other: Face shall be aluminum with a reflective background coating according to the EU vehicle regulatory standards. Fasteners shall be SS. Posts shall be galvanized steel or SS. Refer to Portuguese and EU standards.

UFGS: Section 05 50 13 Miscellaneous Metal Fabrications

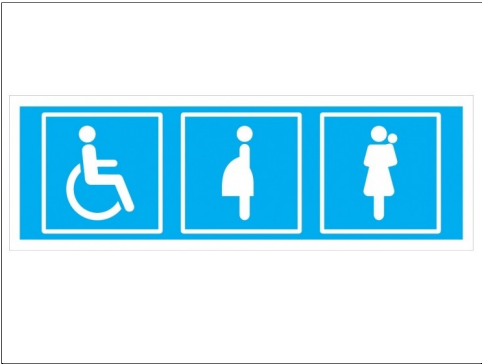

Type: **Handicapped and Specialty Parking Signs**

Applies to: Group 1 Group 2 Group 3 Group 4 Other

Mfr: Sinalux

Color: Blue and White

Finish: Highly reflective aluminum

Model #: P 45 65

Other: Sign face shall be aluminum with a reflective background coating according to "Decreto-Lei n.º 81/2006". Shall be attached to curbs or wheel stops utilizing stainless steel mechanical fasteners.

UFGS: Section 05 50 13 Miscellaneous Metal Fabrications

1. Follow UFC 3-120-01 and AFCFS.

C08.1.9. Regulatory Signs

Applicable N/A Number of base standards 4

Image Tool 250 x 188

Type: **Base Perimeter Warning Sign**

Applies to: Group 1 Group 2 Group 3 Group 4 Other

Mfr: AMAN or Sinalux

Color: Red and White

Finish: Satin vinyl applied to aluminum sheet

Model #: 2 mm thick, 400 mm tall, 600 mm wide

Other: Signs shall be applied on the inside of the perimeter fence (facing out), distances between signs shall be 30m and 1,90m above the ground.

UFGS: Section 05 50 13 Miscellaneous Metal Fabrications

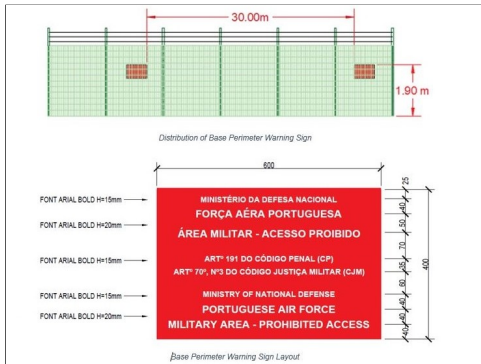

Type: **Secure Area Warning Sign**

Applies to: Group 1 Group 2 Group 3 Group 4 Other

Mfr: AMAN or Sinalux

Color: Yellow and Black

Finish: Satin vinyl applied to aluminum sheet

Model #: 2 mm thick, 400 mm tall, 600 mm wide

Other: N/A

UFGS: Section 05 50 13 Miscellaneous Metal Fabrications

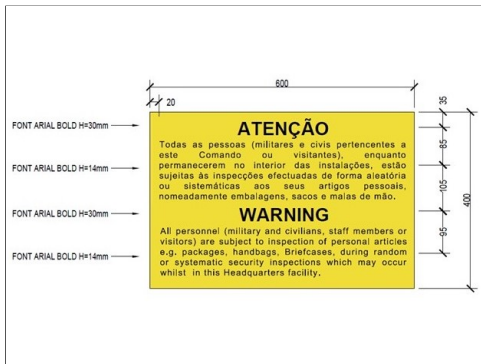

Type: **Prohibited Equipment Sign**

Applies to: Group 1 Group 2 Group 3 Group 4 Other

Mfr: AMAN or Sinalux

Color: Yellow, Red, White and Black

Finish: Satin vinyl applied to aluminum sheet

Model #: 2 mm thick, 400 mm tall, 300 mm wide

Other: N/A

UFGS: Section 05 50 13 Miscellaneous Metal Fabrications

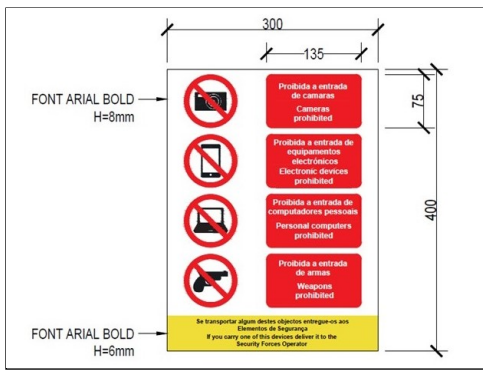

Type: **Restricted Area Signs**

Applies to: Group 1 Group 2 Group 3 Group 4 Other

Mfr: AMAN or Sinalux

Color: Red, White and Black

Finish: Satin vinyl applied to aluminum sheet

Model #: 2 mm thick, 200 mm tall, 200 mm wide

Other: N/A

UFGS: Section 05 50 13 Miscellaneous Metal Fabrications

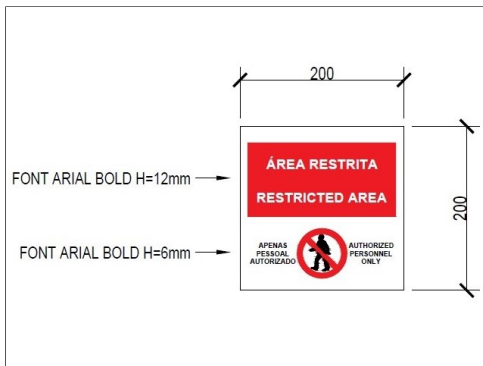

1. Regulatory signage, which restricts, warns and advises, shall be limited to those mandated under Highway/Traffic, Government Warning, and/or Parking Regulation. Follow UFC 3-120-01 and its industry references for color and layout.
2. Provide a comprehensive, systematic approach to regulatory signage to avoid clutter and confusion from “over signage.”
3. Maintain base warning signs for safety and security at the base perimeter and at specific secure areas. Use these to notify visitors of restrictions governing conduct on the base, as well as other security procedures.

C08.1.10. Other

Applicable N/A

Number of base standards 4

Image Tool 250 x 188



Type: **Street Identification Signs**

Applies to: Group 1 Group 2 Group 3 Group 4 Other

Mfr: Custom

Color: Blue and White

Finish: Glazed tile graphics

Model #: Concrete

Other: Precast 75 mm (3 inch) square concrete support posts and a concrete frame design with hand painted blue Azorean glazed tile graphics. Applied at every corner, or as required, to provide needed information.

UFGS: N/A



Type: **Specialty Signs**

Applies to: Group 1 Group 2 Group 3 Group 4 Other

Mfr: Custom

Color: Multiple

Finish: Stone and Glazed tile graphics

Model #: Stone

Other: Should be stone bases that match the architectural elements of the base standards and blue tiles that may be utilized to display sign message or as accent elements. Shall need little or no maintenance.

UFGS: N/A

Type: **GHS Signs**

Applies to: Group 1 Group 2 Group 3 Group 4 Other

Mfr: Sinalux

Color: Multiple

Finish: Satin vinyl applied to aluminum sheet

Model #: Minimum 2 mm (.090 inch) thick plate

Other: Sign messages shall include both Portuguese and English when possible with the Portuguese messages listed above the English translations.

UFGS: Section 05 50 13 Miscellaneous Metal Fabrications

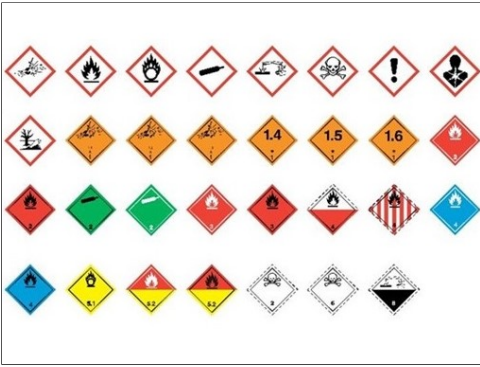

Type: **Warning Signs**

Applies to: Group 1 Group 2 Group 3 Group 4 Other

Mfr: Sinalux

Color: Black and Yellow

Finish: Satin vinyl applied to aluminum sheet

Model #: Minimum 2 mm (.090 inch) thick plate

Other: Sign messages shall include both Portuguese and English when possible with the Portuguese messages listed above the English translations.

UFGS: Section 05 50 13 Miscellaneous Metal Fabrications



C09. LIGHTING

Comply with AF Corporate Standards for Site Development:
<http://afcs.wbdg.org/site-development/index.html>

Comply with AF Corporate Standards for Lighting:
<http://afcs.wbdg.org/site-development/lighting/index.html>

C09.1. Fixtures and Lamping

Applicable N/A Large graphics do not apply

Applicable N/A Select number of graphics / images (small: 250 px x 188 px) to insert 6

Image Tool 250 x 188



LED Parking Lot and Area Lighting



LED Streetlight



Existing Streetlight to be Replaced by LED



Building Mounted Area Lighting



Walls and Stairs Lighting



Outdoor Recreational Area Lighting

1. Provide, coordinate and efficiently install street, parking lot, sidewalk and facility lighting with appropriate luminaires, lamping, placement and spacing following UFC 3-530-01 and Installation Facilities Standards (IFS); ensure the level of quality is consistent with the adjacent facility group number. Pole-mounted, wall-mounted and bollard fixtures are permitted.
2. Integrate controls to automatically reduce lighting power during periods of non-activity; automatically turn off power when sufficient daylight is available.
3. Ensure continuity and consistency of lighting elements. In new construction generally match post types, fixture types, styles, heights, sizes, materials, colors, and lamp types of adjacent facilities and the facility district.
4. Economically provide renewable-energy power sources such as solar photovoltaic when feasible.
5. Use appropriately designed or shielded luminaires to direct light downward to minimize light pollution and intrusion onto adjacent sites and to facilitate night training.
6. Calculate illuminant levels for all lighting applications following UFC 3-530-01 and ensure compliance with pre-curfew maximum brightness level requirements.
7. Sufficiently address environmental factors to prevent corrosion and weathering of fixtures, plinths and other components.
8. Wall mounted fixtures should respond to the architectural character of the facility.

9. Efficient accent lighting of architectural and landscape features may be provided for Group 1, lodging and historical applications. Accent lights in ground-mounted locations may be provided for static displays and signs when these do not conflict or cause hazards with overhead aircraft.
10. Comply with UFC 3-530-01 for light source technology and lamp types. High efficiency lamping such as LED is preferred for most applications.
11. Provide round tapered, square non-tapered, or round non-tapered aluminum poles and aluminum fixtures with square, rectangular or circular housings in colors and shapes to match adjacent facilities and the facility district.
12. Install lighted bollards only at Group 1 and high-traffic Group 2 facilities. Generally match materials, colors and shapes of adjacent facilities and the facility district.
13. Install natural warm gray color, smooth finished concrete bases for all poles in heights appropriate for the facility group and application. Generally Groups 1, 2 and 4 shall have at-grade bases. Group 3 shall have taller bases for added durability.
14. When parking lot lighting is necessary, provide an illuminated path to the building's main entrance. Pole bases should be contained within an internal landscape median or island.
15. Consistently install lighting for sidewalks, bikeways and trails to match adjacent facilities.
16. Landscape accent lighting may be used in public gathering spaces and in Group 1 facilities. Coordinate the design, luminaire selection, and placement with the location of trees, shrubs, and site furnishings.
17. Manufacturers listed below are only provided to establish a baseline of equivalency among all applicable manufacturers.

C09.2. Light Fixture Types

Note: Apply the below base-wide standards for Light Fixtures (products, materials and color). Then refer to the Appendix and apply any additional requirements specifically related to the Facility District in which the project is located.

C09.2.1. Street Lighting

Applicable N/A Number of base standards 1

Image Tool 250 x 188



Type: **Street Lighting (Single or Double)**

Applies to: Group 1 Group 2 Group 3 Group 4 Other

Mfr: MLUX – LED Professional Lighting (Philips)

Color: RAL 7038

Finish: Concrete and/or brush finish powder-coated

Model #: GALAXY 100/40 (LED)

Other: Standard Lumens are 12000lm, CCT shall be 4000K, IP rate shall be a minimum of IP67 and Input Voltage shall be 90-305VAC, 50/60Hz. Support poles may be concrete or aluminum conical pole.

UFGS: N/A

C09.2.2. Parking Lot Lighting

Applicable N/A

Number of base standards 1

Image Tool 250 x 188



Type: **Parking Lot (Single or Double)**

Applies to: Group 1 Group 2 Group 3 Group 4 Other

Mfr: Schröder

Color: RAL 7038

Finish: Brush finish powder-coated

Model #: VONTANA 3 (LED)

Other: Support posts shall be aluminum conical pole with welded aluminum base plate, surface brush finish powder-coated in RAL 7038.

UFGS: N/A

C09.2.3. Lighted Bollards

Applicable N/A

Number of base standards 2

Image Tool 250 x 188



Type: **Lighted Round Dome Top**

Applies to: Group 1 Group 2 Group 3 Group 4 Other

Mfr: Lithonia Lighting Products

Color: Dark Bronze

Finish: Anodized aluminum

Model #: KBA

Other: Flared cone, 3000K LED Lamp. Follow manufacturer's recommendations for fixture base.

UFGS: N/A



Type: **Lighted Square Sloped Top**

Applies to: Group 1 Group 2 Group 3 Group 4 Other

Mfr: Kim Lighting

Color: Platinum Silver

Finish: Anodized aluminum

Model #: VSB1 Square

Other: 3000K LED Lamp, 360° downlighting

UFGS: N/A

C09.2.4. Sidewalk Lighting

Applicable N/A Number of base standards 2

Image Tool 250 x 188



Type: **Sidewalk Lighting**

Applies to: Group 1 Group 2 Group 3 Group 4 Other

Mfr: Schröder

Color: RAL 7038

Finish: Brush finish powder-coated

Model #: VONTANA 3 (LED)

Other: Support posts shall be aluminum conical pole with welded aluminum base plate, surface brush finish powder-coated in RAL 7038.

UFGS: N/A

Type: **Outdoor Area Lighting**



Applies to: Group 1 Group 2 Group 3 Group 4 Other

Mfr: Lledo

Color: RAL 7038

Finish: Brush finish powder-coated

Model #: Alura (LED)

Other: Support posts shall be aluminum conical pole with welded aluminum base plate, surface brush finish powder-coated in RAL 7038.. Shall comply with EN 60598: IP65 and IK10 or greater.

UFGS:

C09.2.5. Walls / Stairs Lighting

Applicable N/A

Number of base standards 1

Image Tool 250 x 188



Type: **Walls / Stairs Lighting**

Applies to: Group 1 Group 2 Group 3 Group 4 Other

Mfr: Lledo

Color: RAL 7038

Finish: Brush finish powder-coated

Model #: INDU WALL PACK (LED)

Other: Walls / Stairs Lighting shall comply with EN 60598: IP65 and IK10 or greater.

UFGS: N/A

C09.2.6. Other

Applicable N/A

Number of base standards 1

Image Tool 250 x 188

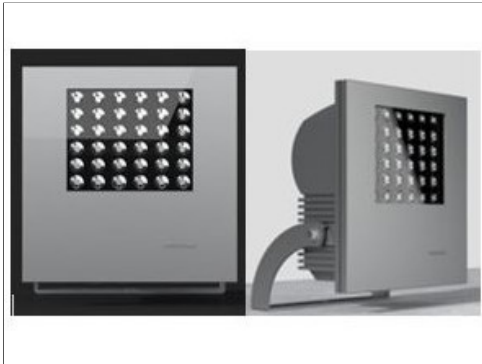

Type: **Building Mounted Area Lighting**

Applies to: Group 1 Group 2 Group 3 Group 4 Other

Mfr: Lledo

Color: RAL 7038

Finish: Brush finish powder-coated

Model #: ARCHITECTURAL LUMINAIRE OD-8200 (LED)

Other: Building Mounted Area Lighting shall comply with EN 60598: IP65 or greater.

UFGS:

D. FACILITIES EXTERIORS

Comply with Air Force Corporate Standards for Facilities Exteriors:

<http://afcs.wbdg.org/facilities-exterior/index.html>

Applicable N/A Select number of graphics / images (large: 800 px x 440 px) to insert 1

Image Tool 800 x 440

Applicable N/A Select number of graphics / images (small: 250 px x 188 px) to insert 3

Image Tool 250 x 188



Base Building Color Standards



Varied Wall and Roof Lines Are Less Institutional



Articulated Rhythm and Pattern



Architectural Expression of Character

D01. SUPPORTING THE MISSION

Comply with AF Corporate Standards for Supporting the Mission:

<http://afcs.wbdg.org/facilities-exterior/supporting-the-mission/index.html>

D02. SUSTAINABILITY

Comply with Air Force Corporate Standards for Sustainability:

<http://afcs.wbdg.org/facilities-exterior/supporting-the-mission/index.html>

D03. ARCHITECTURAL FEATURES

Comply with AF Corporate Standards for Facilities Exteriors:

<http://afcfs.wbdg.org/facilities-exteriors/index.html>

Comply with AF Corporate Standards for Architectural Features:

<http://afcfs.wbdg.org/facilities-exteriors/architectural-features/index.html>

Insert 3 photos for each facility group.

Image Tool 250 x 188

Group 1



Group 2



Group 3



Group 4

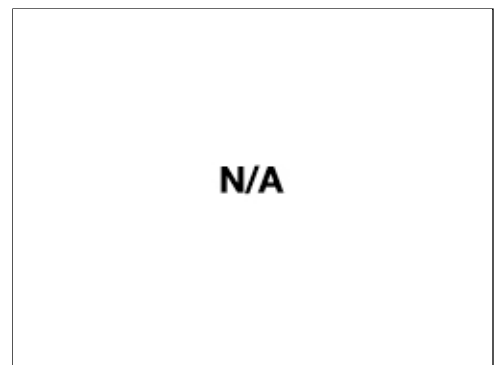
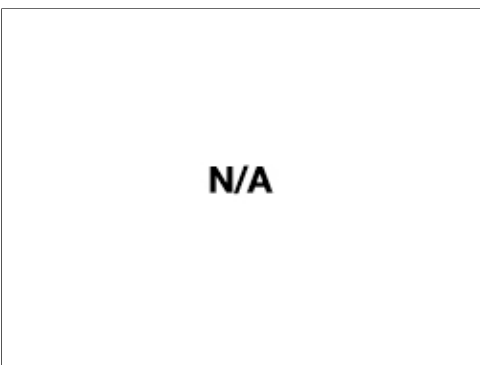

D03.1. Orientation, Massing and Scale

1. Express human scale through architectural components such as water tables, porticos, vestibules, colonnades, secondary roofs, and tile patterns acceptable for the facility group number.
2. Orient new buildings to maximize energy efficiency, passive solar and daylighting potential of the building; narrow buildings oriented along an east-west axis are preferred to minimize heat gain in the summer months and maximize heat gain in the winter months resulting in less overall energy usage.
2. Provide orthogonal geometry for principal building form; angular geometry may be used sparingly for Group 1 and used only for emphasis at specific areas such as building entrances and stairwells.
3. Maintain a human scale and reduce the visual scale of large buildings with sub-massing related to interior functional operations; create consistent form and scale in adjacent buildings with compatible profiles or silhouettes.
4. Develop the junctions between building masses as circulation routes, staircases, utility nodes, or canopies.
5. Building heights shall not be limited; however, building heights over 2 stories shall be considered on a case basis.
6. Combine functions where practical to avoid a proliferation of small, independent structures.
7. Use and coordinate shading devices with orientation and for function.

D03.2. Architectural Character

The design standards in this document have been formulated in response to four principal goals:

- Design facilities that are compatible with Azorean architectural heritage
 - Promote a community or campus atmosphere on the base
 - Ensure buildings project a corporate image for the USAF
 - Leadership in Energy and Environmental Design (LEED) certification (US Standards) or Regulamento das Características de Comportamento Térmico dos Edifícios (RCCTE) and Regulamento dos Sistemas Energéticos de Climatização em Edifícios (RSECE) certification (European Standards)
1. Develop architectural features, materials and detailing appropriate for the Facility Group designation. Refer to Building Entrances, Wall Systems and Roof Systems.
 2. Respond to the local climate and regional influences with environmentally functional architectural features.
 3. For new facilities design generally maintain consistency and visual unity in the character of the adjacent buildings through compatible architectural features: repeated use of similar forms such as roofs, and through recurring elements such as doors, windows, materials and colors but avoid monotony.
 4. Reinforce the Azorean architectural heritage theme.
 5. All facilities shall express sustainability through their orientation, massing, shape, form, materials, and detailing. Provide roof overhangs, louvers, fins and other shading devices to control heat gain and glare and to and improve energy efficiency.
 6. Strive for economical construction without compromising a high-quality, professional appearance.

D03.3. Details and Color

The following five colors have been approved in previous editions of LFFES as the standard paint colors for all buildings located on the main areas of the base, and shall continue in the IFS.

- Cream Beige RAL 1015
- Cattails RAL 8024
- Sudan Brown RAL 8025

- Dark Bronze RAL 8028
 - Pure Red RAL 3028
1. Provide a palette of earth-tone colors related to the native landscape in brick, block, stucco and powder-coated metals. Refer to D05. Wall Systems for detailed material listings.
 2. Relate the level of architectural detailing to the Facility Group number.
 3. Use only integrally colored materials as the predominant exterior building material; do not use materials that require field painting and ongoing maintenance.
 4. Provide consistent and compatible colors for every exterior building feature, including walls, roofs, doors, windows, gutters, downspouts, utility and mechanical elements, and other visible elements.
 5. Noncorrosive metals with factory applied color finishes are required.
 6. Combine details and color with orientation, massing, scale and architectural character to maintain base compatibility.
 7. Exterior paint shall be Water-Based Semi-textured 100% Acrylic. Facades that present fungi or algae on the surface shall be treated accordantly and applied an aqueous disinfectant. Anti-Algae and Fungi shall be added.
 8. The Dark Bronze color shall only be used to paint surfaces until they are replaced with materials that have a factory applied Dark Bronze finish
 9. Manufacturers listed below are only provided to establish a baseline of equivalency among all applicable manufacturers.
 10. See Appendix G for further information.

D03.3.1. Climate-based Data and Life-Cycle Cost-Effective Passive and Natural Design Strategies:

- Climate dominated by mechanical cooling
- Climate dominated by mechanical heating
- Climate with similar mechanical cooling / heating needs
- Climate with minimal mechanical cooling / heating needs
- Climate with high humidity
- Climate with moderate humidity
- Climate with low humidity
- High Solar Insolation
- Moderate Solar Insolation
- Low Solar Insolation
- Soils with High Thermal Conductivity
- Soils with Average Thermal Conductivity

Soils with Low Thermal Conductivity

Other: Consider the potential for flooding and corrosion.

Other:

Facility: Narrow buildings along E-W axis are preferred

Wall: Integral shading features and devices / interior masonry thermal mass walls (for cooling)

Doors: Recessed are preferred

Windows: Provide insulating glazing on north-facing windows / maximize shading for windows on south façades

Roof: High to medium albedo, moderate slope for all buildings except hangars / large industrial facilities

Structure: Do not expose ferrous metals. Provide factory finished non-ferrous metals or concrete

MEP: Ground-source following LCCA

Other: Internal thermal mass walls may be used for cooling following LCCA.

Other:

Note: Apply the below base-wide standards for Architectural Features (products, materials and color). Then refer to the Appendix and apply any additional requirements specifically related to the Facility District in which the project is located.

D03.3.2. Natural Ventilation System

Applicable N/A Number of base standards 1

Image Tool 250 x 188



Type: **Aluminum Windows**

Applies to: Group 1 Group 2 Group 3 Group 4 Other

Mfr: Anicolor (or equivalent)

Color: Dark Bronze RAL 8028 (or other approved by BCE)

Finish: Anodized

Model #: 2x4, slider or awning type

Other: Provide thermally broken frames.

UFGS: Section 08 41 13 Aluminum-Framed Entrances and Storefronts

D03.3.3. Thermal Mass

Applicable N/A

Number of base standards 2

Image Tool 250 x 188

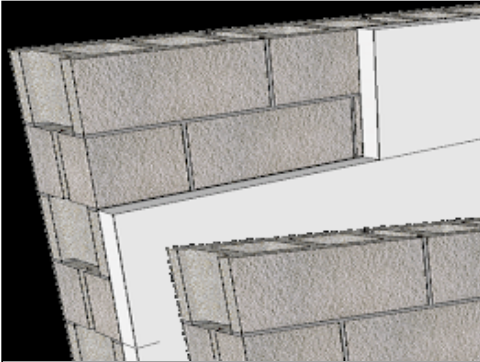

Type: **Expanded Polystyrene insulation (EPS)**

Applies to: Group 1 Group 2 Group 3 Group 4 Other

Mfr: Various

Color: White

Finish: N/A

Model #: Male/female interlocking joint

Other: EPS shall be applied between CMU rows

UFGS: N/A

Type: **Extruded polystyrene insulation (XPS)**

Applies to: Group 1 Group 2 Group 3 Group 4 Other

Mfr: Various

Color: Blue

Finish: N/A

Model #: Male/female interlocking joint

Other: XPS shall be applied between CMU rows

UFGS: N/A



D03.3.4. Thermal Shading

Applicable N/A

Number of base standards 2

Image Tool 250 x 188



Type: **Style 1 Wall Devices**

Applies to: Group 1 Group 2 Group 3 Group 4 Other

Mfr: Anicolor

Color: Dark bronze or Medium Bronze

Finish: Factory, to match frames

Model #: Louver

Other: Shall be aluminum and fasteners shall be stainless steel. Shading devices may be attached to frames. Shading devices may be attached to structure

UFGS: Section 08 41 13 Aluminum-Framed Entrances and Storefronts

Type: **Style 2 Concrete Window Shading**

Applies to: Group 1 Group 2 Group 3 Group 4 Other

Mfr: Custom

Color: Cream Beige

Finish: Painted

Model #: Concrete plateau

Other: N/A

UFGS: Section 03 30 53 Miscellaneous Cast-In-Place Concrete



D03.3.5. Renewable Heating/Cooling

Applicable N/A

Number of base standards 1

Image Tool 250 x 188

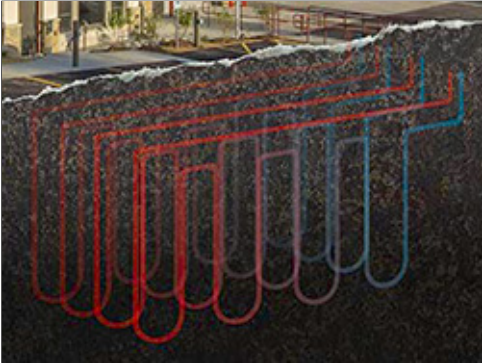

Type: **Style 1 Geothermal (Ground Source)**

Applies to: Group 1 Group 2 Group 3 Group 4 Other

Mfr: Climate Master

Color: N/A

Finish: N/A

Model #: N/A

Other: Vertical ground loop well field

UFGS: Section 23 81 47 Water-Loop and Ground-Loop Heat Pump Systems

D03.3.6. Solar Photovoltaic System

Applicable N/A

D03.3.7. Solar Thermal System

Applicable N/A

D04. BUILDING ENTRANCES

Comply with AF Corporate Standards for Facilities Exteriors:

<http://afcs.wbdg.org/facilities-exteriors/index.html>

Comply with AF Corporate Standards for Building Entrances:

<http://afcs.wbdg.org/facilities-exteriors/building-entrances/index.html>

Insert 3 photos for each facility group.

Image Tool 250 x 188

Group 1



Group 2



Group 3



Group 4

N/A

N/A

N/A

D04.1. Primary Entrances

1. Emphasize the primary entrance in the overall building design with a projecting or recessed covering for weather protection following Installation Facilities Standards (IFS) for Facility Group designations.
2. Provide vestibules at entries in Groups 1, 2 and 3 unless used infrequently or serving unconditioned space following ASHRAE 90.1.
3. Fully integrate all elements including the design of handicap ramps in the overall design of the primary entrance in an organized, uncluttered appearance.
4. Install paved transitional spaces sized for the building function and occupancy.
5. Install appropriate lighting and site furniture following ATFP and IFS.
6. Protect entrances from heavy rains and from direct sun.
7. Provide porte cocheres or covered drop-offs when justified for lodging and medical facilities; do not use for prestige or architectural accents.
8. Locate primary building entrances where they relate to adjacent building entrances and major pedestrian circulation routes.
9. Main entrances should be located away from service entrances and areas.

D04.2. Secondary Entrances

1. Provide vestibules at entries in Groups 1, 2 and 3 unless used infrequently or serving unconditioned space following ASHRAE 90.1; use of stair towers as vestibules for multi-story buildings is encouraged when building and / or energy codes are satisfied.
2. Reflect the character of the primary entrance to a lesser extent with a smaller scale.
3. Include a recess or projection for weather protection and shading.
4. Integrate service and egress doors and loading areas with the building design by matching the materials and detailing and reflect the overall quality of the facility.
5. Incorporate egress structures such as stair towers into the facility design.
6. Canopies may be used for service and loading areas; weather protection beyond weatherstripping is not required at doors used only for life safety egress.
7. Develop building massing and orientation to minimize the appearance of service and loading areas; physically and visually separate these from primary entrances.
8. Loading areas must be organized, orderly and have an uncluttered appearance.

D05. WALL SYSTEMS

Comply with AF Corporate Standards for Facilities Exteriors:

<http://afcfs.wbdg.org/facilities-exteriors/index.html>

Comply with AF Corporate Standards for Doors and Windows:

<http://afcfs.wbdg.org/facilities-exteriors/wall-systems/index.html>

Comply with AFCFS Recommended Materials:

<http://afcfs.wbdg.org/facilities-exteriors/wall-systems/materials/index.html>

Insert 3 photos for each facility group.

Image Tool 250 x 188

Group 1



Group 2



Group 3



Group 4

N/A

N/A

N/A

D05.1. Hierarchy of Materials

1. Group 1 facilities may have more refined detailing than Group 2 and Group 2 may have more definition than Group 3.
2. Group 1 facilities shall be concrete or CMU with a stucco finish and stone water tables with a colorless water repellent and antifungal varnish; Alternative materials may be used also, but requires prior approval from the 765th ABS Engineering. Refer to the Appendix for special requirements of Facility Districts.
3. Group 2 facilities shall be concrete or CMU with a stucco finish and stone water tables with a colorless water repellent and antifungal varnish. Alternative materials may be used also, but requires prior approval from the 765th ABS Engineering.
4. Group 3 facilities shall be aluminum sandwich panel that is placed on 1 meter high CMU wall with a stucco finish.
5. Group 4 does not exist at Lajes Field.
6. Multi-story Group 1 and 2 facilities may include a transition in material or detailing to create a visual base, All Groups shall be limited to a single color Cream Beige RAL 1015.
7. Use high-performance building envelopes following UFC 1-200-02.
8. Use detailing not subject to excessive weathering. Provide wall accents consistently throughout the base.
9. Use integrally colored materials and factory-finished noncorrosive metals. Corrosive metals are not acceptable for exterior walls.
10. Translucent wall panels may be used in Facility Group 1 and recreational uses in Group 2 when protected from direct solar gain. Provide insulating panels and shading appropriate for the orientation and exposure.
11. Do not use EIFS (Exterior insulation finishing system) due to performance problems.
12. Manufacturers listed below are only provided to establish a baseline of equivalency among all applicable manufacturers.

D05.2. Layout, Organization and Durability

1. Organize wall components including doors, windows, accents, shading devices, control joints, etc., to provide an ordered, professional appearance.
2. Integrate shading devices into the overall composition of the wall.
3. Integrate fixed shading devices at all exterior glazing exposed to summer UV heat gain as a passive design measure to reduce energy use. Ensure adequate shading at west entrances. Deciduous trees may be used for shading.
4. Shading systems may be included as part of a manufacturer's window system or may be custom systems integrated into the wall.
5. Provide appropriate transitions between dissimilar materials to mitigate effects of thermal expansion and galvanic action per UFGS 07 60 00 Flashing and Sheet Metal.
6. All joint sealants shall be slightly darker than adjacent surfaces.
7. Materials requiring regular maintenance are not permitted; do not use exposed structural steel or other materials that require painting.
8. Refer to C07.2.16. Screen Walls for materials and colors of freestanding walls.
9. Refer to D07. Roofs for downspouts.

D05.3. Equipment, Vents and Devices

1. Arrange all mechanical, electrical, fire alarm, lightning protection and other system components to create an orderly appearance that integrates with the wall system.
2. Do not expose conduits, cables, piping, lightning protection components, etc. on exterior walls; if unavoidable in renovations, finish these elements to match the adjacent wall surface.
3. Avoid visual clutter and where surface-mounted elements are required and they should comply with Appendix G.

D05.4 Wall Systems Materials

Facility Group 1 wall materials shall be as follows.

Primary: Stucco finish painted and stone water tables

Secondary: Architectural precast

Accent: Optional: Cast-in-Place Concrete

Facility Group 2 wall materials shall be as follows.

Primary: Stucco finish painted and stone water tables

Secondary: Architectural precast

Accent: Optional: Cast-in-Place Concrete

Facility Group 3 wall materials shall be as follows.

Primary: Aluminum Sandwich Panel

Secondary: Stucco finish painted

Accent: Aluminum

Facility Group 4 wall materials shall be as follows.

Primary: N/A

Secondary: N/A

Accent: N/A

Note: Apply the below *base-wide standards* for Wall Systems (products, materials and color). Then refer to the Appendix and apply any additional requirements specifically related to the Facility District in which the project is located.

D05.4.1. Flat Metal Panels

Applicable N/A Number of base standards 1

Image Tool 250 x 188

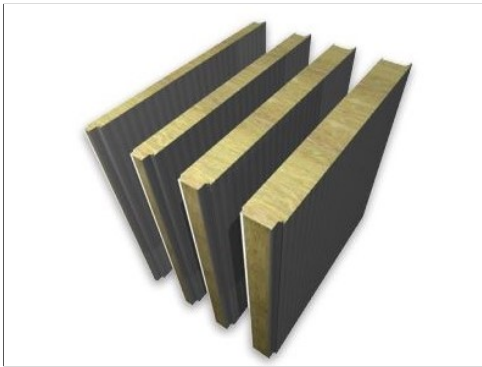

Type: **Aluminum Sandwich Panel**

Applies to: Group 1 Group 2 Group 3 Group 4 Other

Mfr: FTB

Model #: Aluminum Sandwich Panel FTB PF 1000

Color: Cream Beige RAL 1015

Finish: HDX (55 µm) outside and Polyester (25 µm) inside of the panel.

Other: Available thickness 50, 75, 100 and 120 millimeters

UFGS: Section 07 42 13 Metal Wall Panels:
<http://www.wbdg.org/FFC/DOD/UFGS/UFGS 07 42 13.pdf>
Section 07 42 63 Fabricated Wall Panel Assemblies:
<http://www.wbdg.org/FFC/DOD/UFGS/UFGS 07 42 63.pdf>

D05.4.2. Brick Veneer

Applicable N/A

D05.4.3. Architectural Precast

Applicable N/A Number of base standards 1

Image Tool 250 x 188



Type: **Coursed precast**

Applies to: Group 1 Group 2 Group 3 Group 4 Other

Mfr: Local, TBD

Model #: Smooth Casting

Color: Painted Cream Beige RAL 1015

Finish: Very Light texture

Other: N/A

UFGS: Section 03 45 00 Precast Architectural Concrete:
<http://www.wbdg.org/FFC/DOD/UFGS/UFGS 03 45 00.pdf>

D05.4.4. Stucco Over Sheathing

Applicable N/A

Number of base standards 1

Image Tool 250 x 188



Type: **2-Coat Cementitious Stucco**

Applies to: Group 1 Group 2 Group 3 Group 4 Other

Mfr: Mapei

Model #: Traditional 2-coat system

Color: Painted Cream Beige RAL 1015

Finish: Light Texture

Other: Shall be painted with a Water-Based Semi-textured 100% Acrylic paint.

UFGS: Section 09 24 23 Cement Stucco:
http://www.wbdg.org/FFC/DOD/UFGS/UFGS_09_24_23.pdf

D05.4.5. Curtain Wall

Applicable N/A

D05.4.6. Cast-In-Place Concrete

Applicable N/A

D05.4.7. Tilt-Up Concrete

Applicable N/A

D05.4.8. Ribbed Metal Sheeting

Applicable N/A

D05.4.9. EIFS

Applicable N/A

D05.4.10. GFRC

Applicable N/A

D05.4.11. Concrete Block

Applicable N/A

Number of base standards 1

Image Tool 250 x 188



Type: **Concrete masonry unit (CMU)**

Applies to: Group 1 Group 2 Group 3 Group 4 Other

Mfr: Local

Model #: Various

Color: Painted Cream Beige RAL 1015

Finish: 2-Coat Cementitious Stucco

Other:

UFGS: Section 04 20 00 Unit Masonry:

<http://www.wbdg.org/FFC/DOD/UFGS/UFGS 04 20 00.pdf>

D05.4.12. Fiber Cement Siding

Applicable N/A

D05.4.13. Other

Applicable N/A

D06. DOORS AND WINDOWS

Comply with AF Corporate Standards for Facilities Exteriors:

<http://afcfs.wbdg.org/facilities-exteriors/index.html>

Comply with AF Corporate Standards for Doors and Windows:

<http://afcfs.wbdg.org/facilities-exteriors/doors-and-windows/index.html>

Comply with AFCFS Recommended Materials:

<http://afcfs.wbdg.org/facilities-exteriors/doors-and-windows/materials/index.html>

Insert 3 photos for each facility group.

Image Tool 250 x 188

Group 1



Group 2



Group 3



Group 4

N/A

N/A

N/A

D06.1. Types

1. Clear anodized aluminum doors, windows and frames with thermal breaks are preferred for Facility Groups 1-4 because they show less wear and weathering than dark anodized finishes; match the color of the door and frame. For renovation projects the color of new windows, doors and frames may match the existing ones.
2. Standard-sized hinged doors are preferred. Use sliding, folding, overhead, sectional and other door configurations only to support mission operations.
3. Automatic doors are allowed only where functionally necessary.
4. Limit hollow metal doors and frames to security doors, utility rooms and mechanical rooms in Groups 1 and 2 and to any application in Group 3 facilities.
5. Utility and emergency egress doors shall match or be harmonious with the wall color.
6. Passive thermal comfort methods of ventilation are encouraged where life cycle cost justified.
7. Windows must meet force protection requirements.
8. Adjacent joint sealants should be slightly darker than the frame color.
9. Make efforts to contain noise at its source with properly gasketed doors per UFC 3-450-01 Noise and Vibration Control.
10. Manufacturers listed below are only provided to establish a baseline of equivalency among all applicable manufacturers.
11. See Appendix G for additional information.

D06.2. Layout and Geometry

1. Visually and functionally compose openings in walls for the climate-specific exposure.
2. Consistently use opening type, size, placement, mullion pattern, and color to reinforce the overall architectural design.
3. Openings shall augment interior lighting and space conditioning needs.
4. Protect against vandalism and intrusion.

D06.3. Glazing and Shading

1. Tinted, energy-efficient, low-e, double-pane glazing is encouraged; provide triple-pane glazing in extreme environments.
2. Glazing color shall follow Installation Facilities Standards (IFS).
3. Translucent wall panels may be integrated into wall systems.
4. Do not use mirrored glazing.
5. Fully integrate applicable shading designs for overhangs, louvers, light shelves and grilles.
6. Where appropriate, install window screens to take advantage of natural ventilation.

D06.4. Hardware

1. Provide hardware appropriate for the Facility Group while considering activity and frequency of use and local climate; hardware may be of higher visual quality for Facility Group 1.
2. Ensure hardware will perform throughout the facility's lifespan without showing extreme wear.

3. Select finishes that will not degrade by intensity of operation or exposure to the elements.
4. Use consistent finishes and color on window and door systems throughout a facility. For renovation projects the color of new hardware may match the existing hardware.
5. Design building systems to eliminate the need for security screens whenever possible.

D06.5. Doors and Windows Materials

Note: Apply the below base-wide standards for Doors and Windows (products, materials and color). Then refer to the Appendix and apply any additional requirements specifically related to the Facility District in which the project is located.

D06.5.1. Anodized Aluminum

Applicable N/A Number of base standards 1

Image Tool 250 x 188



Type: **Anodized Aluminum Doors, Windows and Frames**

Applies to: Group 1 Group 2 Group 3 Group 4 Other

Mfr: Anicolor - Sistemas de aluminio

Color: Dark Brown Anodized

Finish: Matte

Model #: Thermally broken frames

Other: Air Permeability (EN 1026:2000 & EN 10207) - Min: 4; Water tightness (EN 1027:2000 & EN 12208) - Min: 9A; Wind Resistance (EN 12211:2000 & EN 12210) - Min: C5. Locks shall be Core Type 1C-7-PIN (Best 1C7D1).

UFGS: Section 08 41 13 Aluminum-Framed Entrances and Storefronts:
<http://www.wbdg.org/FFC/DOD/UFGS/UFGS 08 41 13.pdf>

D06.5.2. Hollow Metal

Applicable N/A

D06.5.3. Aluminum-clad Wood

Applicable N/A

D06.5.4. Other

Applicable N/A Number of base standards 1

Image Tool 250 x 188

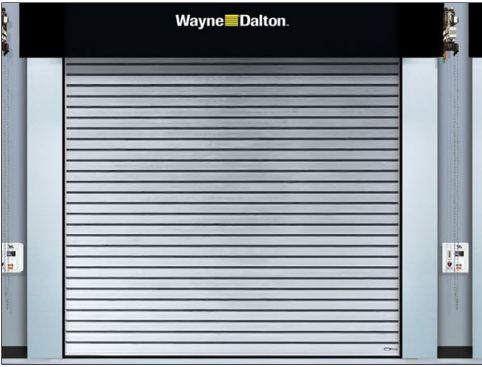

Type: **Rollup doors**

Applies to: Group 1 Group 2 Group 3 Group 4 Other

Mfr: Wayne Dalton

Color: Dark Bronze RAL 8028

Finish: Powder coat Aluminum

Model #: High Speed Metal Doors Model 888 ADV-Xtreme

Other: SS fasteners and other accessories. Corrosive metal is not acceptable. Signaling devices – red/green LED warning light; Full-length weather seals; Bottom wind stop plate; Motion detector or Photo Eye Sensor.

UFGS: N/A

D07. ROOF SYSTEMS

Comply with AF Corporate Standards for Facilities Exteriors:

<http://afcs.wbdg.org/facilities-exterior/index.html>

Comply with AF Corporate Standards for Roof Systems:

<http://afcs.wbdg.org/facilities-exterior/roof-systems/index.html>

Comply with AFCFS Recommended Materials:

<http://afcs.wbdg.org/facilities-exterior/roof-systems/materials/index.html>

Insert 3 photos for each facility group.

Image Tool 250 x 188

Group 1



Group 2



Group 3



Group 4

N/A

N/A

N/A

D07.1. Roof Type and Form

1. Use proven, cost-effective roof systems with high durability, weather resistance, and low maintenance that are compatible with Installation Facilities Standards (IFS) and requirements for the designated Facility Group.
2. Generally match the roof type and form of existing adjacent facilities in new construction.
3. Group 1 and 2 buildings shall use terra-cotta clay Lusa roof tile similar to TECNO from CS Coelho da Silva, SA supplemented with a under tile equivalent to Onduline ST50. Munditelha (Aluminum Sandwich panel) or ISOCOPPO TEK - Aluminum tile shaped insulated panel may be used as approved on a case basis.
4. Provide screens for roof-mounted appendages and equipment of the same materials, which are used predominantly in the building's roof systems.
5. Roof translucent panels and skylights are not permitted in roofs.
6. Group 3 buildings shall use aluminum Sandwich panel similar to Munditelha or ISOCOPPO TEK, depending on the facilities requirements.
7. Group 4 does not exist at Lajes Field.
8. Roof eaves shall extend beyond the exterior wall for roof drainage and shading. Provide overhangs for shading in response to local climatic conditions; these should be sized and proportioned to the height of the facility and to the window openings being shaded.
9. South-facing eaves shall coordinate with adjacent wall-mounted shading devices.
10. The color, shape and slope of the eave and soffit shall be compatible with adjacent facilities.
11. Keep roofs uncluttered and minimize penetrations.
12. Diminish massive roofs into coordinated smaller components consistent with adjacent facilities; avoid random, arbitrary changes.
13. Increase the insulation value of existing roofing systems during renovations if supported by life-cycle cost and structural analysis.
14. Roofs shall be maintained for the life of the system and replaced in accordance with UFC 3-110-04 and AFI 32-1051. A warranty is required on all new roofs.
15. Manufacturers listed below are only provided to establish a baseline of equivalency among all applicable manufacturers.

D07.2. Roof Slope

1. All Groups buildings shall use sloped roofs, min. 3:12 and in accordance with manufactures specifications.
2. Low-sloped roofs are allowed for larger structures or to match existing conditions on renovation projects. Minimal-sloped roofs may also be used for Group 3 facilities in high-visibility areas.
3. Group 4 does not exist at Lajes Field.
4. Ensure adequate drainage and connect to the subsurface rain collection system where available.
5. Provide roof slopes to accommodate solar photovoltaic, solar thermal, passive systems and daylighting when applicable following UFC 1-200-02.
6. Provide underlayments as required for the roofing type as directed by the UFC.

D07.3. Parapets and Copings

1. Do not extend wall materials vertically above the roofline.

D07.4. Color and Reflectivity

1. All new roofs in all Groups shall be terra-cotta color to match adjacent facilities and follow requirements of IFS.
2. All minimal-slope membrane roofs shall use only use high-albedo, high-reflectivity color to help decrease the temperature around the buildings and minimize damage to human and wildlife habitat. This solution shall only be applied in previous constructed building that are not possible to replace existing roof and apply the systems in this IFS.
3. Comply with UFC 3-110-03 and ASHRAE 90.1 for Solar Reflectance Index (SRI) and thermal requirements.
4. All roof flashing shall be Cattails RAL8024 color or the same color as the roof material used.

D07.5. Gutters, Downspouts, Scuppers, Drains

1. All sloped roofs shall use gutters and downspouts. Gutters shall be outside the fascia.
2. Internal roof drainage systems are not permitted in new construction.
3. All gutters and fascias shall be shall be Cattails RAL8024 color.
4. Size the roof drainage system per IBC and SMACNA for the region.
5. Integrate downspouts with the architectural details of the wall system and arrange in an orderly, non-prominent appearance. Generally blend downspouts with the color of the wall (not contrasting it).
6. Fabricate downspouts shall be marine grade aluminum prefinished with a fade resistant architectural grade polyester powder coat paint finish to match the adjacent fascia and wall color (Cream Beige RAL 1015).
7. All downspouts shall be solid.
8. Provide angled transitional pieces for downspouts to fit closely against the wall for their entire length.
9. Coordinate locations of downspouts to conceal control joints in masonry walls when possible.
10. Place downspouts away from building entries. Water discharged should not run across sidewalks.
11. See Appendix G for further information.

D07.6. Roof Vents and Elements

1. Minimize and consolidate roof penetrations into a single, inconspicuous point whenever possible.
2. On sloped roofs clad pipe penetrations to match the roofing material.
3. Avoid the use of rooftop mechanical equipment; however, for renovations and unavoidable configurations, ensure units are screened.
4. Provide access points and service routes to equipment that protect the roof.
5. Screen all large vents.
6. Ensure attic spaces are properly vented at ridges and soffits.
7. Factory finished Dark Bronze color for all exposed equipment and vents.

8. Avoid roof-mounted antenna systems.
9. Arrange Lightning Protection Systems (LPS) components in an ordered, uncluttered and inconspicuous appearance; integrate components into the organization of the roof and wall systems.
10. Ensure that LPS roof mounting systems are approved by the roofing manufacturer.
11. Additions to a roof shall not interfere with LPS or other rooftop systems that may be required.
12. Permanent fall protection shall be included with any addition to a roof with a slope above 3:12 per UFC 3-110-03.
13. Fascia, Flashing, Bargeboard, Soffits and Box End shall be composite aluminum and the standard color is Cattails. See Appendix G for further information.

D07.7. Clerestories and Skylights

1. Clerestories are permitted in Group 1 facilities. These are allowed in Group 3 facilities only when serving passive systems and are justifiable by life-cycle analysis.
2. Clerestories are preferred to skylights to avoid roof penetrations. Skylights are not permitted.
3. Design clerestories using the same principles for seasonal shading that are required for walls and roof overhangs.
4. Translucent panel systems are preferred in clerestory applications due to lack of window cleaning.
5. Clerestories must comply with UFC 4-10-01.

D07.8. Vegetated Roof

1. Are not permitted.

D07.9. Roof Systems Materials

Note: Apply the below base-wide standards for Roof Systems (products, materials and color). Then refer to the Appendix and apply any additional requirements specifically related to the Facility District in which the project is located.

D07.9.1. Standing Seam Metal

Applicable N/A

D07.9.2. Membrane Single-ply

Applicable N/A

D07.9.3. Built-up Multi-ply

Applicable N/A

D07.9.4. Concrete Tile

Applicable N/A

D07.9.5. Clay Tile

Applicable N/A

Number of base standards 1

Image Tool 250 x 188



Type: **Lusa clay tile**

Applies to: Group 1 Group 2 Group 3 Group 4 Other

Mfr: CS Coelho da Silva, SA

Color: Terra-cotta

Finish: Factory

Model #: TECNO

Other: Shall be supplemented with a under tile equivalent to Onduline ST50.

UFGS: Section 07 32 13 Clay Roof Tiles
(Not Available on UFGS)
Section 07 32 14 Clay Tile Roofing Replacement or Repair
<http://www.wbdg.org/FFC/DOD/UFGS/UFGS 07 32 14.pdf>

D07.9.6. Slate Shingles

Applicable N/A

D07.9.7. Vegetated System

Applicable N/A

D07.9.8. Ribbed Metal Sheetting

Applicable N/A

Number of base standards 2

Image Tool 250 x 188



Type: **Style 1**

Applies to: Group 1 Group 2 Group 3 Group 4 Other

Mfr: Mundiperfil Distribuição, Lda

Color: Terra-cotta (RAL 8023)

Finish: HDX (55 µm) outside and Polyester (25 µm) inside of the panel.

Model #: Munditelha

Other: N/A

UFGS: Section 07 41 13.19 Batten-Seam Metal Roof Panels
(Not Available on UFGS)

Type: **Style 2**

Applies to: Group 1 Group 2 Group 3 Group 4 Other

Mfr: ALUBEL S.P.A.

Color: Terra-cotta (RAL 8023)

Finish: HDX (55 µm) outside and Polyester (25 µm) inside of the panel.

Model #: IsoCoppo Tek

Other: N/A

UFGS: Section 07 41 13.19 Batten-Seam Metal Roof Panels
(Not Available on UFGS)

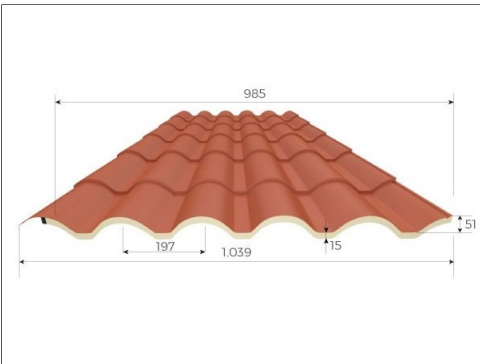

D07.9.9. Composite Shingles

Applicable N/A

D07.9.10. Other

Applicable N/A

Number of base standards 1

Image Tool 250 x 188



Type: **High Strength Polymer**

Applies to: Group 1 Group 2 Group 3 Group 4 Other

Mfr: RENOLIT Tecno Imac

Color: Terracotta

Finish: Factory

Model #: iCoppo

Other: N/A

UFGS: N/A

D08. STRUCTURAL SYSTEMS

Comply with AF Corporate Standards for Facilities Exteriors:

<http://afcs.wbdg.org/facilities-exterior/index.html>

Comply with AF Corporate Standards for Structural Systems:

<http://afcs.wbdg.org/facilities-exterior/structural-systems/index.html>

Comply with AFCFS Recommended Materials:

<http://afcs.wbdg.org/facilities-exterior/structural-systems/materials/index.html>

Insert 3 photos for each facility group.

Image Tool 250 x 188

Group 1



Group 2



Group 3

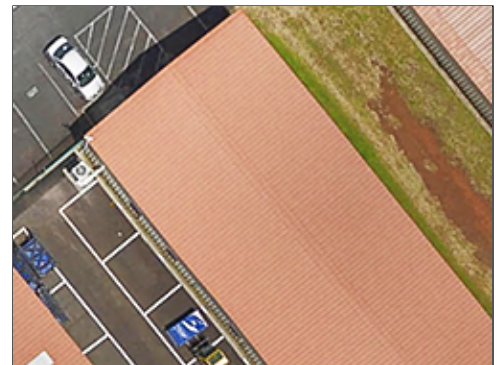

Group 4

N/A

N/A

N/A

D08.1. Systems and Layouts

1. Pre-engineered structural steel framing may be used for Groups 1, 2 and 3 facilities; Installation-appropriate thermal envelopes, materials and detailing are required.
2. Select economical structural systems that integrate roof and wall systems.
3. Narrow buildings 60' or less in width with column-free interiors are preferred for office, administrative and personnel spaces; when interior columns are required optimize the structural grid layout for open-plan arrangements.
4. Fully coordinate structural grids with exterior window systems to align columns with window frames or wall systems.
5. When structure is exposed provide an organized appearance and coordinate with mechanical, electrical, plumbing, fire protection, information technology, and communications systems.
6. Limit the use of specialty systems (such as space frames, vaults or domes) and of structure as a visual feature.
7. Cost-effectively design interior bearing walls as thermal mass.
8. Manufacturers listed below are only provided to establish a baseline of equivalency among all applicable manufacturers.

D08.2. Structural Systems Materials

Note: Apply the below base-wide standards for Structural Systems (products, materials and color). Then refer to the Appendix and apply any additional requirements specifically related to the Facility District in which the project is located.

D08.2.1. Concrete

Applicable N/A

Number of base standards 1

Image Tool 250 x 188



Type: **Cast-In-Place**

Applies to: Group 1 Group 2 Group 3 Group 4 Other

Mfr: Custom

Color: Natural gray

Finish: Light texture

Model #: Post and beam and/or waffle slab

Other: Coordinate with mechanical for chilled beam technologies

UFGS: Section 03 30 53 Miscellaneous Cast-In-Place Concrete
<http://www.wbdg.org/FFC/DOD/UFGS/UFGS 03 30 53.pdf>
Section 03 33 00 Cast-In-Place Architectural Concrete
<http://www.wbdg.org/FFC/DOD/UFGS/UFGS 03 33 00.pdf>
Section 03 47 13 Tilt-Up Concrete
<http://www.wbdg.org/FFC/DOD/UFGS/UFGS 03 47 13.pdf>

D08.2.2. Insulated Concrete Forming (ICF)

Applicable N/A

D08.2.3. Steel

Applicable N/A

Number of base standards 1

Image Tool 250 x 188



Type: **Rigid Framing**

Applies to: Group 1 Group 2 Group 3 Group 4 Other

Mfr: Local TBD

Color: Shop primed

Finish: Matte

Model #: Structural steel shapes

Other: Corrosion protection and painting must comply with ISO 12944: atmospheric corrosion C5 and high durability (>15 years)

UFGS: Section 05 12 00 Structural Steel

http://www.wbdg.org/FFC/DOD/UFGS/UFGS_05_12_00.pdf

D08.2.4. Pre-Engineered Steel

Applicable N/A

Number of base standards 1

Image Tool 250 x 188



Type: **Moment Frame**

Applies to: Group 1 Group 2 Group 3 Group 4 Other

Mfr: Behlen Building Systems

Color: Factory primed

Finish: Matte

Model #: Moment Frame

Other: Draped insulation may be used behind wall finish system; Corrosion protection and painting must comply with ISO 12944: atmospheric corrosion C5 and high durability (>15 years)

UFGS: Section 13 12 00 Steel Building Systems
(Not Available on UFGS)

Section 13 34 19 Metal Building Systems

http://www.wbdg.org/FFC/DOD/UFGS/UFGS_13_34_19.pdf

D08.2.5. Masonry

Applicable N/A

D08.2.6. Heavy Timber

Applicable N/A

D08.2.7. Light-gauge Steel

Applicable N/A Number of base standards 1

Image Tool 250 x 188

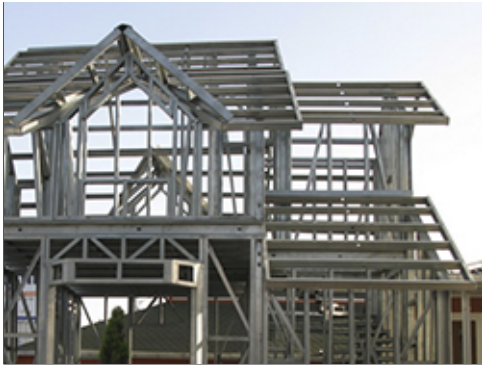

Type: **Steel Framing**

Applies to: Group 1 Group 2 Group 3 Group 4 Other

Mfr: Steelrite

Color: Factory

Finish: Galvanized

Model #: Structural framing shapes

Other: Corrosion protection and painting must comply with ISO 12944: atmospheric corrosion C5 and high durability (>15 years)

UFGS: Section 05 45 00 Light Gauge Steel Framing System
(Not Available on UFGS)

D08.2.8. Lumber Framing

Applicable N/A

D08.2.9. Other

Applicable N/A

D09. MECHANICAL, ELECTRICAL AND PLUMBING

Comply with AF Corporate Standards for Facilities Exteriors:

<http://afcs.wbdg.org/facilities-exteriors/index.html>

Comply with AF Corporate Standards for Mechanical, Electrical and Plumbing:

<http://afcs.wbdg.org/facilities-exteriors/machanical-electrical-and-plumbing/index.html>

Insert 3 photos for each facility group.

Image Tool 250 x 188

Group 1



Group 2



Group 3

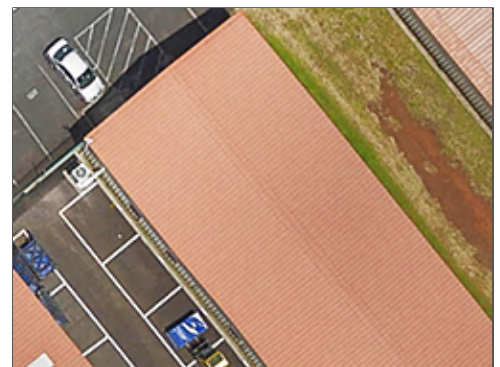

Group 4

N/A

N/A

N/A

D09.1. Passive and Active Systems

1. Fully integrate passive heating and cooling systems into facility designs whenever practical for the local climate prior to the design of active mechanical systems.
2. Provide optimized passive and active systems; design active mechanical systems to supplement thermal mass walls and floors.
3. Develop renewable-energy systems including geo-exchange (ground source heat pumps) when life cycle cost effective.
4. Performance display screens, which report energy performance and utility savings, are encouraged; when provided locate these in building lobbies or common areas.
5. Solar domestic hot water systems are required when life-cycle cost effective for the climate.
6. Integrate shading into building exteriors to reduce solar heat gain during hot seasons.

D09.2. Functionality and Efficiency

1. Fully coordinate mechanical, electrical, plumbing (MEP) and fire protection systems with each other and with the building structure, enclosure, thermal envelope and interior design.
2. Ensure direct exterior access is provided (for CE) to main mechanical and electrical rooms.
3. Screen exterior equipment from primary views (landscape, building masses, screen walls) and comply with ATEP requirements.
4. Keep equipment away from main building entrances; locate service area/yard on least visible side of a building.
5. Coordinate the location of all exterior meters, equipment and devices to provide convenient access and an overall coordinated and orderly appearance.
6. Design emergency generator systems integrally with all other building systems and avoid incompatible building additions; locate generators near service areas and ensure they are not visible from primary entrances.
7. When structure is exposed as a finished ceiling, fully integrate MEP and fire protection systems to provide an organized, uncluttered appearance.
8. Conceal ducts, piping, conduits, devices, etc., when permanent walls, suspended ceilings or raised floors are provided; locate sprinkler heads in orderly configuration.
9. Limit interior wall-mounted equipment in occupied personnel spaces; avoid surface-mounted conduit and pipes.
10. Provide efficient utility rooms with layouts to facilitate system performance and maintenance; provide convenient access to controls, clearly label systems and include operating and maintenance instructions.
11. Separate mechanical and electrical and communications rooms.
12. Integrate recessed and wall-mounted fixtures such as fire standpipe cabinets and drinking fountains within permanent walls.
13. See Appendix G for additional information.

E. FACILITIES INTERIORS

Comply with Air Force Corporate Standards for Facilities Interiors:
<http://afcs.wbdg.org/facilities-interiors/index.html>

Insert 3 photos for each facility group.

Image Tool 250 x 188

Group 1

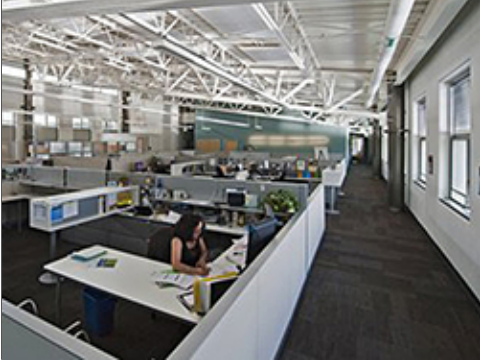

Group 2

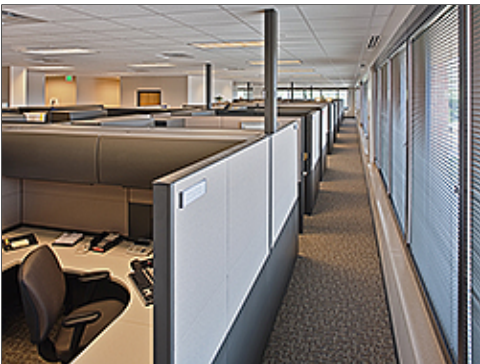

Group 3



Group 4

N/A

N/A

N/A

E01. Building Configurations

Comply with Air Force Corporate Standards for Building Configurations:

<http://afcfs.wbdg.org/facilities-interiors/buildings-configurations/index.html>

1. Provide open-plan configurations for office, administrative, operational and related activities and spaces for maximum flexibility. Use a “core and shell” approach in which all building systems, infrastructure and permanent interior partitions anticipate two or more uses (operations) during a facility's life span.
2. Create flexible interior configurations using Furniture, Fixtures & Equipment (FF&E) and limit private offices and private rooms. Refer to AFMAN 32-1084 for space requirements. To the greatest extent, limit permanent partitions to core areas such as toilet rooms, stairs, mechanical and utility rooms.
3. Use more durable long-lasting finishes in core areas for walls, ceilings, floor coverings and built-in casework. Coordinate interior FF&E layouts with structural grids during space planning.
4. Provide high-performance building configurations following UFC 1-200-02. Ensure passive design strategies are cost effectively incorporated before active mechanical systems are designed.
5. Comply with UFC 1-200-01, general building requirements. UFC 1-200-01 provides applicability of model building codes and government unique criteria for typical design disciplines and building systems, as well as for accessibility, antiterrorism, security, high performance and sustainability requirements, and safety.
6. Meet security and force protection requirements in UFC 4-010-01: DoD Minimum Antiterrorism Standards for Buildings.
7. Comply with AFCFS for supporting mission requirements, addressing human comfort and wellbeing, and creating highly flexible interiors while satisfying metrics for high performance and sustainable buildings.
8. Provide a level of quality for interior features, materials and finishes that is appropriate for the Facility Group number. Group 1 may receive higher quality than Groups 2 thru 4. Refer to Facility Hierarchy.
9. Through open-plan configurations, preserve all passive and natural design strategies and fully integrate facility interiors with overall building systems.
10. Professional interior designers, or architects with significant interior design experience, must accomplish the design and review of applicable new construction, renovations and maintenance projects.
11. Consult with the State Historic Preservation Officer (SHPO) and base-level Historic Preservation offices regarding proposed changes to properties listed on or eligible for listing on the National Register of Historic Places. Follow requirements of The National Historic Preservation Act and Secretary of the Interior Standards for the Treatment of Historic Properties.
12. Maintain architectural compatibility following AFCFS and this Installation Facilities Standards (IFS) document to create continuity while avoiding monotony.

E01.1. Layout and Common Areas

Comply with Air Force Corporate Standards for Layout and Common Areas:

<http://afcfs.wbdg.org/facilities-interiors/buildings-configurations/layout-and-common-areas/index.html>

1. Create open-plan interior environments to accommodate changes.
2. Limit interior partitions, private offices and rooms; use furniture or modular systems to provide privacy and acoustic control.
3. When partitions are functionally justified such as for conference rooms, use systems furniture and moveable (demountable) floor-to-ceiling wall systems for acoustical or visual privacy.
4. Proportion lobbies and common spaces based on type of function, activity and facility group.

5. Allow no direct sight lines into restrooms.
6. Situate utility and core areas to minimize impact on daylighting and to maximize use as thermal buffers.
7. Ensure electrical, lighting and communications system can be adaptable to configuration changes.
8. Avoid power poles to the maximum extent; when poles are necessary minimize the number and coordinate locations with furniture placement and other elements.
9. Avoid sloping floors to maintain flexibility and eliminate future structural changes.
10. Special consideration may apply to Sensitive Compartmented Information Facilities (SCIFs).

E01.1.1. Interior Design Process

1. Comply with UFC 3-120-10 for the Comprehensive Interior Design (CID,) which includes both Structural Interior Design (SID) and Furniture, Fixtures & Equipment (FF&E) design services.
2. Use a collaborative, integrated planning and design team, composed of user, government support staff, and appropriate professionals. Integrate architectural features using simple detailing to create a professional appearance; avoid extravagant or excessive detailing.
3. Ensure interior designs satisfy the functional requirements within the context of flexibility, sustainability and the building's energy performance.
4. Base space planning on square foot allocations from AFM 32-1084. Identify special requirements if any, such as privacy separation, VIP areas, gathering spaces and storage. Note: The occupant's rank and position will influence the square footage and selection of materials.
5. Provide clear circulation and pathway finding for both horizontal and vertical directions that accommodate the number of personnel in the facility.
6. Maximize efficiencies in the space plan for functional relationships and adjacencies for all facility users. Efficiently create and situate rooms and support rooms such as conference / meeting rooms and break rooms.
7. Provide interior design building-related illustrations, drawings, schedules, materials selections, specifications and cost estimates as listed in UFC 3-120-10. Refer to Furnishings in this IFS also.
8. SID Format shall follow UFC 3-120-10.
9. Base the FF&E package on the furniture footprint developed in the SID. Identify all new or existing equipment needed and its users within each facility or each area of the facility. Provide specific information on: equipment sizes, electrical requirements, ventilation requirements, weight (if heavy), quantity, and security level if required. Presume all administrative spaces have computers and supporting equipment.

E01.1.2. Codes and Regulations

1. Refer to UFC 1-200-01 for modifications to the International Building Code (IBC) to determine applicable sections of the IBC. Both the IBC Chapter 3 and UFC 3-600-01 govern "Use and Occupancy Classification" for example.
2. Fire code requirements shall be as defined in the International Building Code (IBC) and must be used where dictated by UFC 1-200-01 DoD Building Code (General Building Requirements) except where noted in UFC 3-600-01 (Fire Protection Engineering For Facilities).
3. National Fire Protection Association (NFPA) 101 must be utilized to determine the occupancy classification as it relates to fire/smoke resistance rating of interior non-load bearing partitions (other than occupancy separation), means of egress, interior finish, features of fire protection (including vertical openings) and associated requirements.

E01.2. Quality and Comfort

Comply with Air Force Corporate Standards for Quality and Comfort:

<http://afcs.wbdg.org/facilities-interiors/buildings-configurations/quality-and-comfort/index.html>

1. Include durability in the life-cycle cost analysis for best-value material selections with long life expectancies that do not show excessive wearing.
2. Select long-lasting materials and finishes for permanent core areas such as lobbies, restrooms and stairs.
3. Select low-maintenance materials and products that reduce ongoing servicing and repair and that are easy to clean.
4. Relate the visual quality of finishes to the Facility Group number.
5. Building and interior configurations should address both operations and climatic responses.
6. Convey a professional image; avoid trendy patterns and textures.
7. Use materials and finishes that provide a healthy indoor environment.
8. Orient interior spaces toward views while maintaining cost-effective building performance and efficiency.
9. Promote air movement and daylighting for human health and wellbeing.

E02. Floors

Comply with Air Force Corporate Standards for Floors:

<http://afcs.wbdg.org/facilities-interiors/floors/index.html>

E02.1. Floor Materials

Facility Group 1 floor materials shall be as follows.

Primary: Hydrocork floors
Secondary: Prepared Slabs (Ground, Polished)
Tertiary: Carpet, Porcelain Tile, VCT

Facility Group 2 floor materials shall be as follows.

Primary: Hydrocork floors
Secondary: Prepared Slabs (Ground, Polished)
Tertiary: Carpet, Porcelain Tile, VCT

Facility Group 3 floor materials shall be as follows.

Primary: Prepared Slabs (Polished concrete)
Secondary: Prepared Slabs (Ground, Polished)
Tertiary: Porcelain Tile, VCT

Facility Group 4 floor materials shall be as follows.

Primary: N/A
Secondary: N/A
Tertiary: N/A

1. Natural stone and terrazzo flooring may be used in high traffic areas of Group 1 as approved on a case basis.
2. Resilient and rapidly renewable flooring may be used in low traffic areas in Group 1 and 2.
3. Manufacturers listed below are only provided to establish a baseline of equivalency among all applicable manufacturers.

Note: Apply the below base-wide standards for Floors (products, materials and color). Then refer to the Appendix and apply any additional requirements specifically related to the Facility District in which the project is located.

E02.1.1. Prepared Slabs

Applicable N/A Number of base standards 2

Image Tool 250 x 188



Type: **Style 1, Ground and Polished**

Applies to: Group 1 Group 2 Group 3 Group 4 Other

Mfr: Local (TBD)

Color: Natural gray cement, light to dark beige aggregates

Finish: Fine polished texture

Model #: Medium to small aggregate

Other: N/A

UFGS: Section 03 35 45 Polished Concrete Finishing
(Not Available on UFGS)

Type: **Style 2, Polished concrete**

Applies to: Group 1 Group 2 Group 3 Group 4 Other

Mfr: Local (TBD)

Color: Natural gray cement, light to dark beige aggregates

Finish: Medium polished texture, slip resistant

Model #: Medium to small aggregate

Other: N/A

UFGS: Section 03 35 45 Polished Concrete Finishing
(Not Available on UFGS)



E02.1.2. Natural Stone and Terrazzo

Applicable N/A

E02.1.3. Quarry Tile

Applicable N/A

Number of base standards 1

Image Tool 250 x 188



Type: **Style 1**

Applies to: Group 1 Group 2 Group 3 Group 4 Other

Mfr: Daltile

Color: Earth tones

Finish: Matte, slip resistant

Model #: N/A

Other: Use in commercial kitchen flooring.

UFGS: Section 09 30 10 Ceramic, Quarry, and Glass Tiling
<http://www.wbdg.org/FFC/DOD/UFGS/UFGS 09 30 10.pdf>

E02.1.4. Ceramic Tile

Applicable N/A

Number of base standards 3

Image Tool 250 x 188

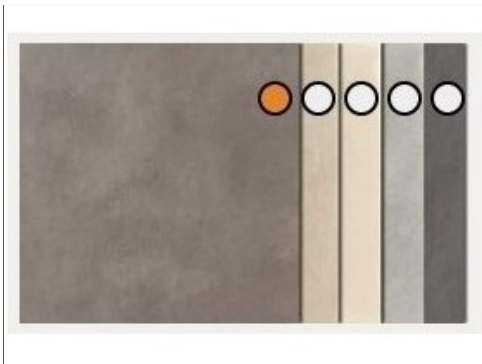

Type: **Style 1 Porcelain Ceramic**

Applies to: Group 1 Group 2 Group 3 Group 4 Other

Mfr: Magres (Gres Panaria Portugal S.A)

Color: Taupe; Cream; Snow; Silver; Carbon

Finish: Slip Resistance (R11 or R10)

Model #: EDGE

Other: 60cm x 60cm (24" x 24"). Ceramic tile color shall be selected by 765th ABS.

UFGS: Section 09 30 10 Ceramic, Quarry, and Glass Tiling
<http://www.wbdg.org/FFC/DOD/UFGS/UFGS 09 30 10.pdf>

Type: **Style 2 Porcelain Ceramic**

Applies to: Group 1 Group 2 Group 3 Group 4 Other

Mfr: Magres (Gres Panaria Portugal S.A)

Color: Clay; White; Ash; Smoke

Finish: Slip Resistance (R11 orNR)

Model #: SUBWAY

Other: 60cm x 60cm (24" x 24"). Ceramic tile color shall be selected by 765th ABS.

UFGS: Section 09 30 10 Ceramic, Quarry, and Glass Tiling
<http://www.wbdg.org/FFC/DOD/UFGS/UFGS 09 30 10.pdf>

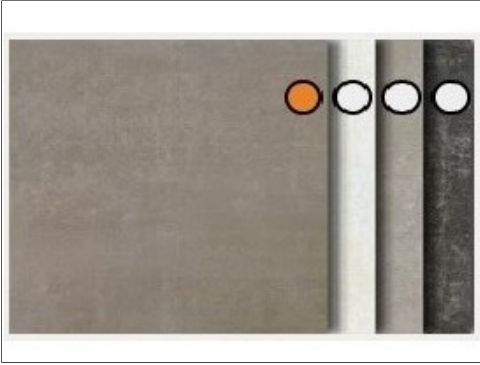

Type: **Style 3 Porcelain Ceramic**

Applies to: Group 1 Group 2 Group 3 Group 4 Other

Mfr: Magres (Gres Panaria Portugal S.A)

Color: Tortora; White; Light Grey; Grey

Finish: Slip Resistance (R11 orNR)

Model #: TOOL

Other: 60cm x 60cm (24" x 24"). Ceramic tile color shall be selected by 765th ABS.

UFGS: Section 09 30 10 Ceramic, Quarry, and Glass Tiling
<http://www.wbdg.org/FFC/DOD/UFGS/UFGS 09 30 10.pdf>



E02.1.5. Resilient Floor

Applicable N/A

Number of base standards 4

Image Tool 250 x 188



Type: **Style 1 Vinyl Composition Tile (VCT)**

Applies to: Group 1 Group 2 Group 3 Group 4 Other

Mfr: Tarkett

Color: Dark Grey

Finish: Factory

Model #: 12" x 12" (305 mm x 305 mm)

Other: N/A

UGFS: Section 09 65 00 Resilient Flooring

<http://www.wbdg.org/FFC/DOD/UGFS/UGFS 09 65 00.pdf>

Type: **Style 2 Vinyl Composition Tile (VCT)**

Applies to: Group 1 Group 2 Group 3 Group 4 Other

Mfr: Tarkett

Color: Beige Taupe

Finish: Factory

Model #: 12" x 12" (305 mm x 305 mm)

Other: N/A

UGFS: Section 09 65 00 Resilient Flooring

<http://www.wbdg.org/FFC/DOD/UGFS/UGFS 09 65 00.pdf>





Type: **Style 3 Vinyl Composition Tile (VCT)**

Applies to: Group 1 Group 2 Group 3 Group 4 Other

Mfr: Tarkett

Color: Blue Lagoon

Finish: Factory

Model #: 12" x 12" (305 mm x 305 mm)

Other: N/A

UFGS: Section 09 65 00 Resilient Flooring
<http://www.wbdg.org/FFC/DOD/UFGS/UFGS 09 65 00.pdf>

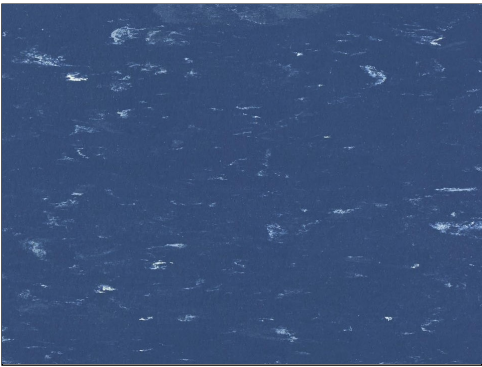

Type: **Style 4 Vinyl Composition Tile (VCT)**

Applies to: Group 1 Group 2 Group 3 Group 4 Other

Mfr: Tarkett

Color: Hudson Blue

Finish: Factory

Model #: 12" x 12" (305 mm x 305 mm)

Other: N/A

UFGS: Section 09 65 00 Resilient Flooring
<http://www.wbdg.org/FFC/DOD/UFGS/UFGS 09 65 00.pdf>

E02.1.6. Carpet

Applicable N/A

Number of base standards 3

Image Tool 250 x 188

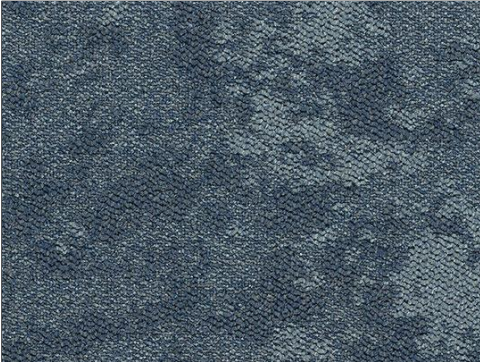

Type: **Style 1 Carpet**

Applies to: Group 1 Group 2 Group 3 Group 4 Other

Mfr: Forbo

Color: 3406 sirocco blue

Finish: N/A

Model #: Tessera cloudscape SOFTbac

Other: 50cm x 50cm (20" x 20")

UGFS: UFGS 09 68 00 Carpeting

<http://www.wbdg.org/FFC/DOD/UGFS/UGFS 09 68 00.pdf>



Type: **Style 2 Carpet**

Applies to: Group 1 Group 2 Group 3 Group 4 Other

Mfr: Forbo

Color: 3415 gulf stream

Finish: N/A

Model #: Tessera cloudscape SOFTbac

Other: 50cm x 50cm (20" x 20")

UGFS: UFGS 09 68 00 Carpeting

<http://www.wbdg.org/FFC/DOD/UGFS/UGFS 09 68 00.pdf>



Type: **Style 3 Carpet**

Applies to: Group 1 Group 2 Group 3 Group 4 Other

Mfr: Forbo

Color: 3410 stormy weather

Finish: N/A

Model #: Tessera cloudscape SOFTbac

Other: 50cm x 50cm (20" x 20")

UFGS: UFGS 09 68 00 Carpeting
<http://www.wbdg.org/FFC/DOD/UFGS/UFGS 09 68 00.pdf>

E02.1.7. Rapidly-Renewable Products

Applicable N/A

E02.1.8. Other

Applicable N/A

Number of base standards 3

Image Tool 250 x 188

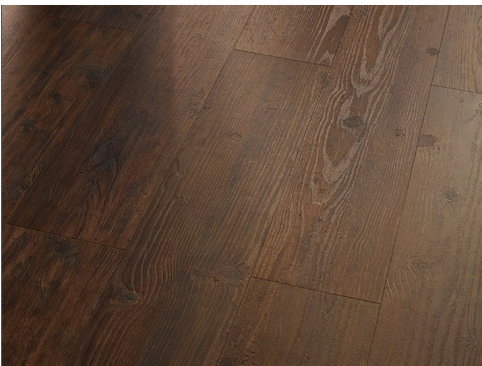

Type: **Style 1 Textile Floor Covering Systems**

Applies to: Group 1 Group 2 Group 3 Group 4 Other

Mfr: WICANDERS

Color: Century Morocco Pine

Finish: Slightly textured

Model #: Hydrocork

Other: N/A

UFGS: N/A



Type: **Style 2 Textile Floor Covering Systems**

Applies to: Group 1 Group 2 Group 3 Group 4 Other

Mfr: WICANDERS

Color: Rustic Grey Oak

Finish: Slightly textured

Model #: Hydrocork

Other: N/A

UFGS: N/A



Type: **Style 3 Textile Floor Covering Systems**

Applies to: Group 1 Group 2 Group 3 Group 4 Other

Mfr: WICANDERS

Color: Elegant Oak

Finish: Slightly textured

Model #: Hydrocork

Other: N/A

UFGS: N/A

E03. Walls

Comply with Air Force Corporate Standards for Walls:
<http://afcs.wbdg.org/facilities-interiors/walls/index.html>

E03.1. Wall Materials

Facility Group 1 wall materials shall be as follows.

Primary: Cement Plaster over CMU
Secondary: Gypsum Board (GB) (painted)
Tertiary: Ceramic tile (restrooms)

Facility Group 2 wall materials shall be as follows.

Primary: Brick
Secondary: Gypsum Board (GB) (painted)
Tertiary: Ceramic tile (restrooms)

Facility Group 3 wall materials shall be as follows.

Primary: Ground face block, sealed (do not paint)
Secondary: Cement Plaster, Pre-finished aluminum panel , GB
Tertiary: Ceramic tile (restrooms)

Facility Group 4 wall materials shall be as follows.

Primary: N/A
Secondary: N/A
Tertiary: N/A

1. Follow UFC 3-450-01 (Vibration and Noise Control) for acoustic design issues including speech privacy, sound isolation or sound masking.
2. Select and apply paint with sheens (gloss levels) appropriate for the application following UFGS Section 09 90 00 Paints and Coatings.
3. Provide ceramic tile on wet walls of kitchens, toilet rooms, locker rooms, etc., in all facility groups.
4. Neutral split-face or ground-face integrally colored block with a clear sealer may be used in Group 3. Do not paint block.
5. Provide rubber base on drywall partitions in Groups 1 and 2.
6. Hardwood base may only be used in Group 1 as approved on a case basis.
7. Hardwood chair rails / bumper rails may be used in high-use areas of Groups 1 and 2; aqueous clear finishes are preferred to reduce maintenance; plastic chair rails are permitted only in medical applications.
8. Decorative moldings may be used only in Group 1 when approved on a case basis.
9. Corner guards are permitted only in high traffic spaces with wheeled or cart use such as private service areas in Groups 1 and 2; stainless steel corners guards with a brushed finish may be judiciously used in Group 3.
10. Manufacturers listed below are only provided to establish a baseline of equivalency among all applicable manufacturers.

Note: Apply the below *base-wide standards* for Walls (products, materials and color). Then refer to the Appendix and apply any additional requirements specifically related to the Facility District in which the project is located.

E03.1.1. Concrete

Applicable N/A

E03.1.2. Masonry

Applicable N/A

Number of base standards 1

Image Tool 250 x 188



Type: **CMU Back-up with Cement Plaster Finish**

Applies to: Group 1 Group 2 Group 3 Group 4 Other

Mfr: Local (TBD)

Color: Painted - Color Scheme, Appendix G.

Finish: Light texture

Model #: 2-coat cementitious system

Other: N/A

UFGS: Section 04 20 00 Unit Masonry

<http://www.wbdg.org/FFC/DOD/UFGS/UFGS 04 20 00.pdf>

E03.1.3. Ceramic Tile

Applicable N/A

Number of base standards 1

Image Tool 250 x 188

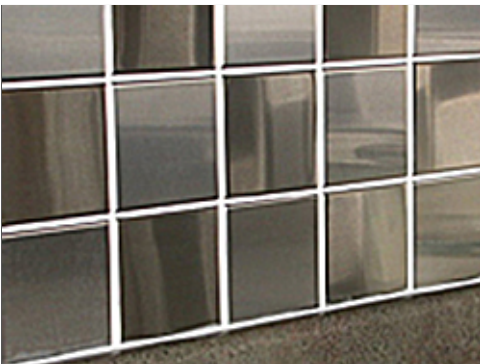

Type: **Style 1**

Applies to: Group 1 Group 2 Group 3 Group 4 Other

Mfr: Daltile

Color: Earth tones

Finish: Gloss, Semi-gloss

Model #: Ceramic wall tile

Other: Located on wet walls in restrooms

UFGS: Section 09 30 10 Ceramic, Quarry, and Glass Tiling

<http://www.wbdg.org/FFC/DOD/UFGS/UFGS 09 30 10.pdf>

E03.1.4. Gypsum Board

Applicable N/A

Number of base standards 1

Image Tool 250 x 188



Type: **Style 1**

Applies to: Group 1 Group 2 Group 3 Group 4 Other

Mfr: Knauf

Color: Color Scheme, See Attachment G.

Finish: Paint (Sheen per UFGS)

Model #: Tapered edge

Other: N/A

UFGS: Section 09 29 00 Gypsum Board
<http://www.wbdg.org/FFC/DOD/UFGS/UFGS 09 29 00.pdf>
Section 09 90 00 Paints and Coatings
<http://www.wbdg.org/FFC/DOD/UFGS/UFGS 09 90 00.pdf>

E03.1.5. Metal Panels

Applicable N/A

Number of base standards 1

Image Tool 250 x 188

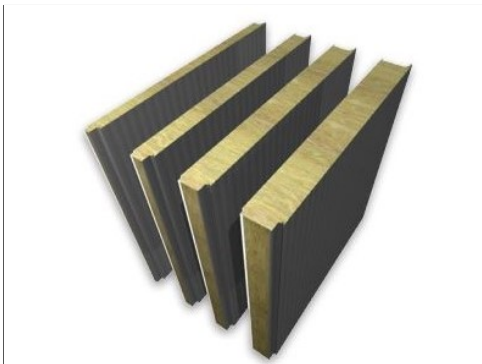

Type: **Aluminum Sandwich Panel**

Applies to: Group 1 Group 2 Group 3 Group 4 Other

Mfr: FTB

Color: White

Finish: Factory

Model #: N/A

Other: Aluminum panels referred to in this section, are the inside of the sandwich panels applied to construct exterior wall (D05.4.1. Flat Metal Panels).

UFGS: Section 05 72 00 Decorative Metal Specialties
<http://www.wbdg.org/FFC/DOD/UFGS/UFGS 05 72 00.pdf>

E03.1.6. Wood Paneling

Applicable N/A

E03.1.7. Rapidly-Renewable Products

Applicable N/A

Number of base standards 3

Image Tool 250 x 188



Type: **Style 1 HPL Wall Coverings**

Applies to: Group 1 Group 2 Group 3 Group 4 Other

Mfr: Formica

Color: 929 Oyster Grey (Mate)

Finish: Factory

Model #: HardStop Decorative Protection Panels

Other: 900 mm (3 feet) to 1000 mm (3 feet, 6 inches). See Attachment G for further information.

UFGS: Section 09 74 13 Decorative Wood Wall Panels
(Not Available on UFGS)

Type: **Style 2 HPL Wall Coverings**

Applies to: Group 1 Group 2 Group 3 Group 4 Other

Mfr: Formica

Color: 920 Almond (Mate)

Finish: Factory

Model #: HardStop Decorative Protection Panels

Other: 900 mm (3 feet) to 1000 mm (3 feet, 6 inches). See Attachment G for further information.

UFGS: Section 09 74 13 Decorative Wood Wall Panels
(Not Available on UFGS)





Type: **Style 3 HPL Wall Coverings**

Applies to: Group 1 Group 2 Group 3 Group 4 Other

Mfr: Formica

Color: 1994 Fox (Mate)

Finish: Factory

Model #: HardStop Decorative Protection Panels

Other: 900 mm (3 feet) to 1000 mm (3 feet, 6 inches). See Attachment G for further information.

UFGS: Section 09 74 13 Decorative Wood Wall Panels
(Not Available on UFGS)

E03.1.8. Other

Applicable N/A

Number of base standards 5

Image Tool 250 x 188



Type: **Style 1 Wall Base**

Applies to: Group 1 Group 2 Group 3 Group 4 Other

Mfr: Tarkett - Johnsonite, Inc.

Color: 48 Grey WG

Finish: Factory

Model #: Vinyl

Other: See Attachment G for further information.

UFGS: N/A



Type: **Style 2 Wall Base**

Applies to: Group 1 Group 2 Group 3 Group 4 Other

Mfr: Tarkett - Johnsonite, Inc.

Color: TA3 Castaway CB

Finish: Factory

Model #: Vinyl

Other: See Attachment G for further information.

UFGS: N/A



Type: **Style 3 Wall Base**

Applies to: Group 1 Group 2 Group 3 Group 4 Other

Mfr: Local

Color: Natural hardwood

Finish: Clear Sealer, satin (aqueous)

Model #: Wood

Other: See Attachment G for further information

UFGS: N/A



Type: **Style 1 Wall Protection**

Applies to: Group 1 Group 2 Group 3 Group 4 Other

Mfr: Local

Color: Natural hardwood

Finish: Clear Sealer, satin (aqueous)

Model #: Wood

Other: See Attachment G for further information.

UFGS: N/A



Type: **Style 1 Wall Protection**

Applies to: Group 1 Group 2 Group 3 Group 4 Other

Mfr: Local

Color: Natural hardwood

Finish: Clear Sealer, satin (aqueous)

Model #: Wood

Other: See Attachment G for further information.

UFGS:

E04. Ceilings

Comply with Air Force Corporate Standards for Ceilings:
<http://afcs.wbdg.org/facilities-interiors/ceilings/index.html>

E04.1. Ceiling Materials

Facility Group 1 ceiling materials shall be as follows.

Primary: Grid and Acoustical Tile

Secondary: Gypsum board (painted)

Tertiary:

Facility Group 2 ceiling materials shall be as follows.

Primary: Grid and Acoustical Tile

Secondary: Gypsum board (painted)

Tertiary:

Facility Group 3 ceiling materials shall be as follows.

Primary: Exposed Framing (Roof / Floor Structure Above)

Secondary: Grid and Acoustical Tile (Offices)

Tertiary: Gypsum board (painted)

Facility Group 4 ceiling materials shall be as follows.

Primary: N/A

Secondary: N/A

Tertiary: N/A

1. Accent ceiling materials such as metal, wood, and rapidly renewable may be used in Group 1 as approved on a case basis.
2. Follow UFC 3-450-01 (Vibration and Noise Control) for acoustic design issues including speech privacy, sound isolation or sound masking.
3. Manufacturers listed below are only provided to establish a baseline of equivalency among all applicable manufacturers.

Note: Apply the below *base-wide standards* for Ceilings (products, materials and color). Then refer to the Appendix and apply any additional requirements specifically related to the Facility District in which the project is located.

E04.1.1. Exposed Framing (Roof / Floor Structure Above)

Applicable N/A

Number of base standards 1

Image Tool 250 x 188



Type: **Style 1**

Applies to: Group 1 Group 2 Group 3 Group 4 Other

Mfr: Vulcraft

Color: Neutral colors reviewed on a case basis

Finish: Field painted (Sheen per UFGS)

Model #: Formlok floor and roof decking

Other: N/A

UFGS: Section 05 30 00 Steel Decks
http://www.wbdg.org/FFC/DOD/UFGS/UFGS_05_30_00.pdf

E04.1.2. Exposed Concrete

Applicable N/A

E04.1.3. Grid and Acoustical Tile

Applicable N/A Number of base standards 2

Image Tool 250 x 188

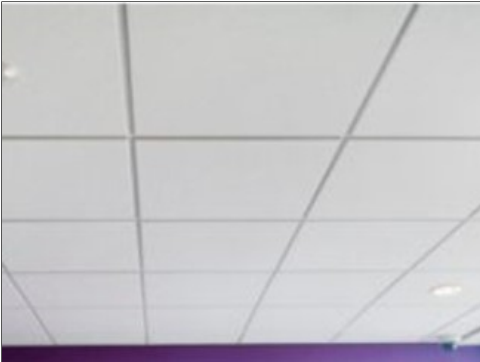

Type: **Style 1**

Applies to: Group 1 Group 2 Group 3 Group 4 Other

Mfr: Armstrong

Color: White

Finish: Factory

Model #: SIERRA OP

Other: Performance characteristics are Class A; NRC-0.85; LR- 84%; minimum recycled content 79%. See Attachment G for further information.

UFGS: Section 09 51 00 Acoustical Ceilings
<http://www.wbdg.org/FFC/DOD/UFGS/UFGS 09 51 00.pdf>

Type: **Style 2**

Applies to: Group 1 Group 2 Group 3 Group 4 Other

Mfr: Armstrong

Color: White

Finish: Factory

Model #: Hydroboard (Restrooms)

Other: Performance characteristics are Class A; NRC-0.90; LR- 82%; minimum recycled content 20%. See Attachment G for further information.

UFGS: Section 09 51 00 Acoustical Ceilings
<http://www.wbdg.org/FFC/DOD/UFGS/UFGS 09 51 00.pdf>



E04.1.4. Gypsum Board

Applicable N/A

Number of base standards 1

Image Tool 250 x 188



Type: **Style 1**

Applies to: Group 1 Group 2 Group 3 Group 4 Other

Mfr: Knauf

Color: White

Finish: Paint (sheen per UFGS)

Model #: Tapered edge

Other: N/A

UFGS: Section 09 29 00 Gypsum Board

http://www.wbdg.org/FFC/DOD/UFGS/UFGS_09_29_00.pdf

Section 09 90 00 Paints and Coatings

http://www.wbdg.org/FFC/DOD/UFGS/UFGS_09_90_00.pdf

E04.1.5. Metal Panels

Applicable N/A

E04.1.6. Wood

Applicable N/A

E04.1.7. Rapidly-Renewable Products

Applicable N/A

E04.1.8. Other

Applicable N/A

E05. Doors and Windows

Comply with Air Force Corporate Standards for Doors and Windows:

<http://afcs.wbdg.org/facilities-interiors/doors-and-windows/index.html>

E05.1. Doors and Windows and Frames Materials

Facility Group 1

door (frame) and window frame materials shall be as follows.

Primary: Wood

Secondary: Hollow metal (painted)

Tertiary: N/A

Facility Group 1

door (leaf) materials shall be as follows.

Primary: Wood Solid Core

Secondary: Hollow metal (galvanized, painted)

Tertiary: N/A

Facility Group 2

door (frame) and window frame materials shall be as follows.

Primary: Wood

Secondary: Hollow metal (galvanized, painted)

Tertiary: N/A

Facility Group 2

door (leaf) materials shall be as follows.

Primary: Wood Solid Core

Secondary: Hollow metal (galvanized, painted)

Tertiary: N/A

Facility Group 3

door (frame) and window frame materials shall be as follows.

Primary: Hollow metal (galvanized, painted)

Secondary: Aluminum, Black anodized

Tertiary: N/A

Facility Group 3

door (leaf) materials shall be as follows.

Primary: Hollow metal (galvanized, painted)

Secondary: Aluminum, wood anodized

Tertiary: N/A

Facility Group 4

door (frame) and window frame materials shall be as follows.

Primary: N/A

Secondary: N/A

Tertiary: N/A

Facility Group 4

door (leaf) materials shall be as follows.

Primary: N/A

Secondary: N/A

Tertiary: N/A

1. Hardwood casings may be provided over metal frames in Group 1 as approved on a case basis.
2. Do not use hollow-core wood doors.
3. Generally match original hardware in renovations.
4. Manufacturers listed below are only provided to establish a baseline of equivalency among all applicable manufacturers.

Note: Apply the below *base-wide standards* for Doors and Windows (products, materials and color). Then refer to the Appendix and apply any additional requirements specifically related to the Facility District in which the project is located.

E05.1.1. Aluminum

Applicable N/A

Number of base standards 1

Image Tool 250 x 188



Type: **Style 1**

Applies to: Group 1 Group 2 Group 3 Group 4 Other

Mfr: Kawneer

Color: Anodized

Finish: Factory

Model #: InFrame Interior Framing, (2x4 nominal framing)

Other: Satin stainless steel hardware. Standard core is Stainless Steel Best Lock - Cores Core Type 1C-7-PIN (Best 1C7D1 – Standard Interchangeable core),.

UFGS: Section 08 41 13 Aluminum-Framed Entrances and Storefronts
<http://www.wbdg.org/FFC/DOD/UFGS/UFGS 08 41 13.pdf>
Section 08 71 00 Door Hardware
<https://www.wbdg.org/FFC/DOD/UFGS/UFGS 08 71 00.pdf>

E05.1.2. Hollow Metal

Applicable N/A

Number of base standards 2

Image Tool 250 x 188



Type: **Steel Doors**

Applies to: Group 1 Group 2 Group 3 Group 4 Other

Mfr: Steelcraft

Color: Neutral colors

Finish: Paint (Sheen per UFGS)

Model #: Hollow metal, 2" w. frames, 16 gauge (welded corners) grouted solid

Other: Provide in Group 3 and in utility areas of Group 1 and 2. Provide A25 "galvannealed" coating. All interior steel doors shall have a factory applied primer finish. Provide satin stainless steel hardware.

UFGS: Section 08 11 13 Steel Doors and Frames
<http://www.wbdg.org/FFC/DOD/UFGS/UFGS 08 11 13.pdf>
Section 08 71 00 Door Hardware
<https://www.wbdg.org/FFC/DOD/UFGS/UFGS 08 71 00.pdf>

Type: **Steel Frames**

Applies to: Group 1 Group 2 Group 3 Group 4 Other

Mfr: Steelcraft

Color: Neutral colors

Finish: Paint (Sheen per UFGS)

Model #: Hollow metal, frame grouted solid

Other: Satin stainless steel hardware

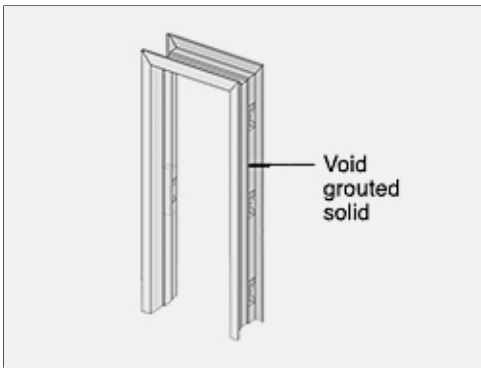

UFGS: Section 08 11 13 Steel Doors and Frames
<http://www.wbdg.org/FFC/DOD/UFGS/UFGS 08 11 13.pdf>
Section 08 71 00 Door Hardware
<https://www.wbdg.org/FFC/DOD/UFGS/UFGS 08 71 00.pdf>

E05.1.3. Wood

Applicable N/A

Number of base standards 2

Image Tool 250 x 188

Type: **Style 1 Executive office and conference areas**

Applies to: Group 1 Group 2 Group 3 Group 4 Other

Mfr: Local

Color: Natural hardwood

Finish: Clear Sealer, satin (aqueous)

Model #: Solid core wood 1 meter (3 feet) wide x 2.1 meters (6 feet, 8 inches)

Other: Satin stainless steel hardware. Door stopper similar to IN.13.121.30.ECO by JNF. Four or six panel embossed wood doors. Core is Stainless Steel Best Lock - Cores Core Type 1C-7-PIN.



UFGS: Section 08 14 00 Wood Doors
<http://www.wbdg.org/FFC/DOD/UFGS/UFGS 08 14 00.pdf>
Section 08 71 00 Door Hardware
<https://www.wbdg.org/FFC/DOD/UFGS/UFGS 08 71 00.pdf>

Type: **Style 2 Administrative office and other areas**

Applies to: Group 1 Group 2 Group 3 Group 4 Other

Mfr: Local

Color: Natural hardwood

Finish: Clear Sealer or paint, satin (aqueous)

Model #: Full slab or panels

Other: Satin stainless steel hardware. Door stopper similar to IN.13.121.30.ECO by JNF. Core is Stainless Steel Best Lock - Cores Core Type 1C-7-PIN.

UFGS: Section 08 14 00 Wood Doors
<http://www.wbdg.org/FFC/DOD/UFGS/UFGS 08 14 00.pdf>
Section 08 71 00 Door Hardware
<https://www.wbdg.org/FFC/DOD/UFGS/UFGS 08 71 00.pdf>

E05.1.4. Other

Applicable N/A

E06. Casework Systems

Comply with Air Force Corporate Standards for Casework Systems:
<http://afcfs.wbdg.org/facilities-interiors/casework-systems/index.html>

E06.1. Casework Materials

1. Select casework systems and materials considering durability, maintenance requirements and LCCA.
2. Natural stone and cast stone countertops may only be used in Group 1 with approval on a case basis.
3. Metal cabinets and countertops shall be provided in heavy-use operations and in Group 3.
4. Refer to AFCFS for approved materials.
5. Manufacturers listed below are only provided to establish a baseline of equivalency among all applicable manufacturers.

E06.1.1. Plastic Laminate

Applicable N/A

Number of base standards 1

Image Tool 250 x 188



Type: **Style 1, Low Use Areas**

Applies to: Group 1 Group 2 Group 3 Group 4 Other

Mfr: Formica

Color: Medium Earth tones and neutral tones

Finish: Light textured

Model #: High pressure laminate

Other: Combine with matching solid-surface banding on casework edges.

UFGS: Section 06 41 16.00 10 Plastic-Laminate-Clad Architectural Cabinets
http://www.wbdg.org/FFC/DOD/UFGS/UFGS_06_41_16.00_10.pdf

E06.1.2. Solid Polymer Surface

Applicable N/A

Number of base standards 1

Image Tool 250 x 188



Type: **Style 1, High Use Areas**

Applies to: Group 1 Group 2 Group 3 Group 4 Other

Mfr: Corian

Color: Medium Earth tones and neutral tones

Finish: Light textured

Model #: Solid Surface

Other: Faces and edge banding

UFGS: Section 12 36 00 Countertops
http://www.wbdg.org/FFC/DOD/UFGS/UFGS_12_36_00.pdf

E06.1.3. Rapidly-Renewable Products

Applicable N/A

Number of base standards 1

Image Tool 250 x 188



Type: **Style 1 Moderate Use Areas**

Applies to: Group 1 Group 2 Group 3 Group 4 Other

Mfr: Plyboo

Color: Natural or amber

Finish: Satin

Model #: Flat grain bamboo plywood

Other: FSC® Certified 100%.

UFGS: Section 12 32 00 Manufactured Wood Casework
<http://www.wbdg.org/FFC/DOD/UFGS/UFGS 12 32 00.pdf>

E06.1.4. Metal

Applicable N/A

Number of base standards 1

Image Tool 250 x 188



Type: **Style 1**

Applies to: Group 1 Group 2 Group 3 Group 4 Other

Mfr: Steel Sentry

Color: Natural stainless steel or neural colors (steel)

Finish: Mill (stainless) or Powder coated (steel)

Model #: Lab, workbench, computer workstation

Other: Provide highly durable fabrications and finishes in Group 3 which are subjected to heavy use.

UFGS: Section 12 31 00 Manufactured Metal Casework
<http://www.wbdg.org/FFC/DOD/UFGS/UFGS 12 31 00.pdf>

E06.1.5. Other

Applicable N/A

E06.2. Countertop Materials

E06.2.1. Plastic Laminate

Applicable N/A Number of base standards 1

Image Tool 250 x 188



Type: **Style 1, Low Use Areas**

Applies to: Group 1 Group 2 Group 3 Group 4 Other

Mfr: Formica

Color: Medium Earth tones and neutral tones

Finish: Light textured

Model #: High pressure laminate

Other: Only use rounded half or full bullnose and integral backsplash. Do not use plastic laminate edge banding on front edges.

UFGS: Section 06 41 16.00 10 Plastic-Laminate-Clad Architectural Cabinets
http://www.wbdg.org/FFC/DOD/UFGS/UFGS_06_41_16.00_10.pdf

E06.2.2. Solid Polymer Surface

Applicable N/A Number of base standards 1

Image Tool 250 x 188



Type: **Style 1, High Use Areas**

Applies to: Group 1 Group 2 Group 3 Group 4 Other

Mfr: Corian

Color: Medium Earth tones and neutral tones

Finish: Light textured

Model #: Solid Surface

Other: Faces and edges

UFGS: Section 12 36 00 Countertops
http://www.wbdg.org/FFC/DOD/UFGS/UFGS_12_36_00.pdf

E06.2.3. Natural Stone

Applicable N/A

Number of base standards 1

Image Tool 250 x 188



Type: **Style 1, Group 1 High Visibility, Heavy Use**

Applies to: Group 1 Group 2 Group 3 Group 4 Other

Mfr: Local (TBD)

Color: Neutral tones

Finish: High polish, sealer

Model #: Custom cut slabs

Other: N/A

UFGS: Section 12 36 00 Countertops

[http://www.wbdg.org/FFC/DOD/UFGS/UFGS 12 36 00.pdf](http://www.wbdg.org/FFC/DOD/UFGS/UFGS_12_36_00.pdf)

E06.2.4. Cast Stone

Applicable N/A

Number of base standards 1

Image Tool 250 x 188

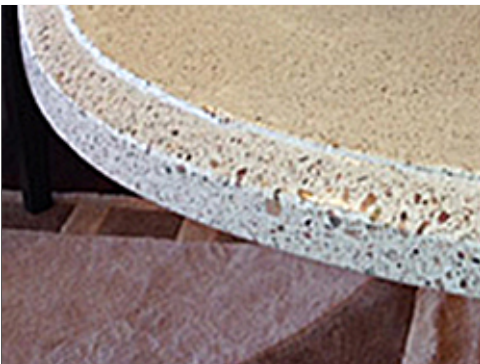

Type: **Style 1, Group 1 High Visibility, Heavy Use**

Applies to: Group 1 Group 2 Group 3 Group 4 Other

Mfr: Local (TBD)

Color: Neutral tones

Finish: High polish, sealer

Model #: Custom cast or cut slabs

Other: N/A

UFGS: Section 12 36 00 Countertops

[http://www.wbdg.org/FFC/DOD/UFGS/UFGS 12 36 00.pdf](http://www.wbdg.org/FFC/DOD/UFGS/UFGS_12_36_00.pdf)

E06.2.5. Metal

Applicable N/A

Number of base standards 1

Image Tool 250 x 188



Type: _____

Applies to: Group 1 Group 2 Group 3 Group 4 Other

Mfr: Local (TBD)

Color: Natural stainless steel

Finish: Mill

Model #: Custom fabricated countertops

Other: Provide integral fronts, sides and backsplash

UGFS: Section 12 31 00 Manufactured Metal Casework
<http://www.wbdg.org/FFC/DOD/UGFS/UGFS 12 31 00.pdf>

E06.2.6. Other

Applicable N/A

E07. Furnishings

Comply with Air Force Corporate Standards for Furnishings:
<http://afcs.wbdg.org/facilities-interiors/furnishings/index.html>

E07.1. Durability and Serviceability

Comply with AF Corporate Standards for Durability and Serviceability:
<http://afcs.wbdg.org/facilities-interiors/furnishings/durability-and-serviceability/index.html>

E07.2. Accessories

Comply with AF Corporate Standards for Accessories:
<http://afcs.wbdg.org/facilities-interiors/furnishings/accessories/index.html>

1. Comply with AFCFS.
2. See Attachment G - Plumbing Fixtures and Equipment for further information.

E08. Interior Signs

Comply with Air Force Corporate Standards for Interior Signs:
<http://afcs.wbdg.org/facilities-interiors/interior-signs/index.html>

E08.1 Types and Color

Comply with Air Force Corporate Standards for Types and Color:
<http://afcfs.wbdg.org/facilities-interiors/interior-signs/types-and-color/index.html>

E08.2. Interior Signs Materials

1. Natural stone, masonry and cast stone signs may only be used in Group 1 with approval on a case basis.
2. Comply with AFCFS.
3. See Attachment G - Interior Signs for further information.

E09. Lighting, Power and Communication

<http://afcfs.wbdg.org/facilities-interiors/lighting-power-and-communication/index.html>

E09.1. Functionality and Efficiency

Comply with Air Force Corporate Standards for Functionality and Efficiency:
<http://afcfs.wbdg.org/facilities-interiors/lighting-power-and-communication/functionality-and-efficiency/index.html>

E09.2. Types and Color

1. Comply with AFCFS.
2. See Attachment G - Lighting, Power and Communication for further information.

F. APPENDIX - Facility Districts

- Applicable
- N/A

Comply with Air Force Corporate Standards for Facility Districts:

<http://afcs.wbdg.org/facility-districts/index.html>

Facilities Districts Overview Map:

Image Tool 800 x 600

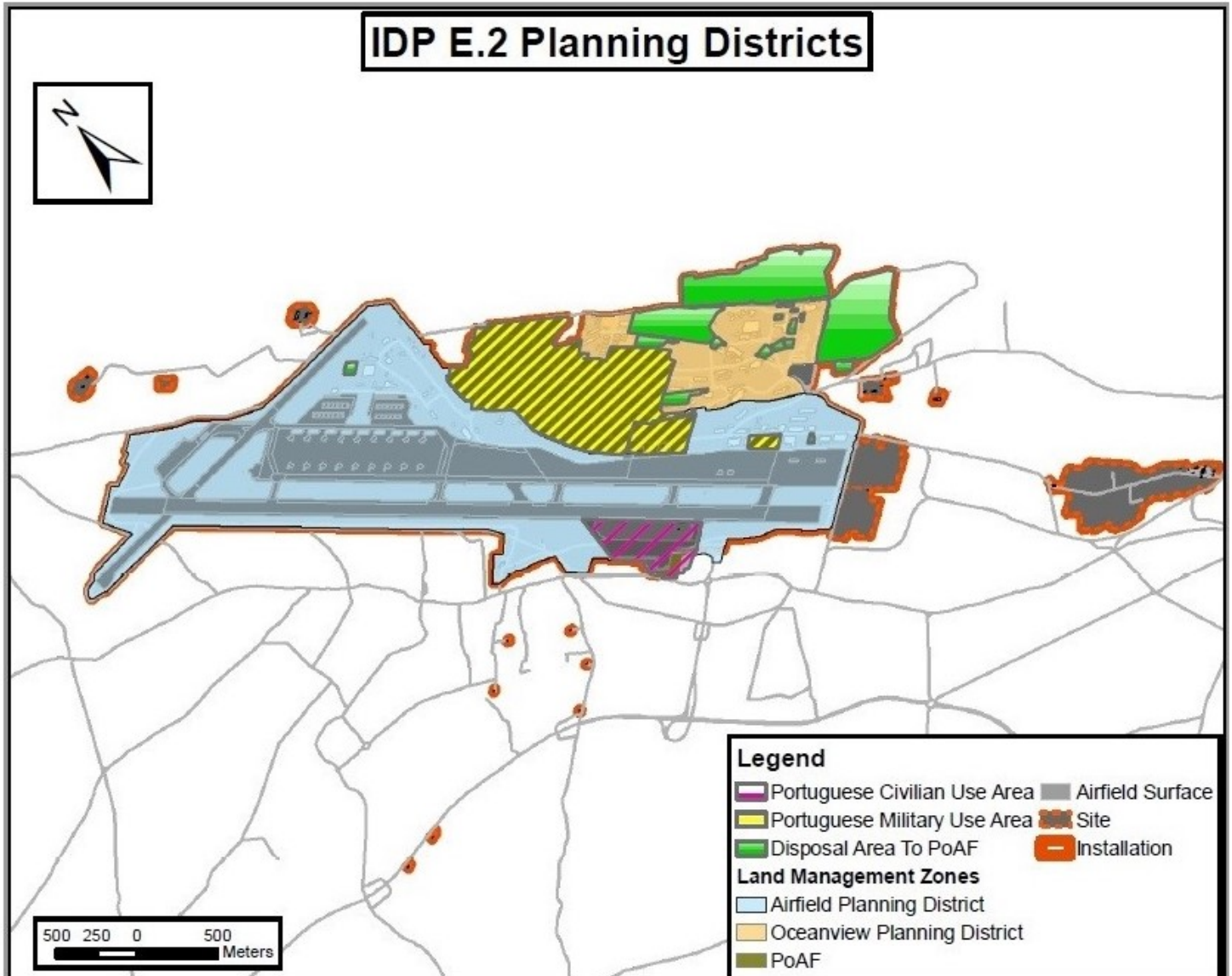

Note: Apply the *base-wide standards* in this IFS for *Installation Elements, Site Development, Facilities Exteriors and Facilities Interiors* (products, materials, color, etc.). Following application of the base-wide standards, refer to the Appendix and apply any additional requirements specifically related to the Facility District.

Enter No. of Facility Districts 0

The following Facility Districts list exceptions to the base standards that are unique to each district. Please refer to the Site Development, Facilities Exteriors, and Facilities Interiors sections of this IFS for base standards.

Name of District: Base-wide Standards

Image Tool 800 x 600

Map of District



Photos for each facility group within the Facility District as applicable.

Image Tool 250 x 188

Group 1 Applicable N/A

Group 2 Applicable N/A

Group 3 Applicable N/A

Group 4 Applicable N/A

Other Applicable N/A

FACILITY DISTRICTS

Lajes Field is divided into districts that align with land use zones as defined in the Installation Development Plan. Each district has designated uses that support the base's operations. Generally match adjacent facilities in new construction to promote architectural compatibility throughout the installation. Please refer to Section D03.2. and contact the 765th ABS Engineering for additional information. A brief description of each district follows.

1. Administrative

Facilities in the Administrative District should continue to be pedestrian in scale. Application of the installation prevailing architectural theme, Azorean Heritage, should be implemented during major renovations or new construction as appropriate with features and detailing acceptable for the Facility Group number.

2. Community

The Community District should be pedestrian in scale. Application of the installation prevailing architectural theme, Azorean Heritage, should be implemented during major renovations or new construction as appropriate with features and detailing acceptable for the Facility Group number.

3. Industrial / Flightline

The Industrial / Flightline District includes facilities that are industrial in nature and may support flightline operations. Alternative uses include warehouses for various base activities including maintenance, storage, utility functions, industrial services, transportation storage, communications, civil engineering, supply and equipment, fuel storage, vehicle maintenance/motor pool complex, open storage, emergency/disaster response facilities, ordnance and weapons storage areas, and other industrial uses. Facilities in this district are industrial in nature, should generally match adjacent buildings to ensure architectural compatibility and shall follow standards for Facility Group 3 as defined in this IFS.

4. Family Housing

The Family Housing District currently does not exist at Lajes Field.

5. Recreation

The Recreation District includes outdoor areas that are very important to the quality of life at Lajes AFB. Uses included are (parks, picnic areas, jogging paths, athletic fields and baseball, and football fields). Facilities in this district are pedestrian in scale and, in many areas, are directly adjacent to open spaces further enhancing the aesthetic qualities of this district. Application of the installation prevailing architectural theme, Azorean Heritage, should be implemented during major renovations or new construction as appropriate with features and detailing acceptable for the Facility Group number.

6. Open Space and Preserves

Open space includes undeveloped land both inside and outside of the immediate cantonment area. It both separates and defines the various sections of the base and creates a natural setting for the cantonment area. Areas classified as open space may be undeveloped to act as a buffer space between incompatible uses or for safety or security clearances or there may be other constraints that are not readily visible. All development in this district requires prior coordination and approval from the 765th ABS Engineering.

G. APPENDIX - References

Comply with Air Force Corporate Standards:

<http://afcfs.wbdg.org/index.html>

Note: The below listed Supplementary Documents are provided as part of this IFS and shall become fully part of the IFS. If there are any discrepancies between the requirements of this IFS and the Supplementary Documents, the IFS shall govern.

765th ABS Engineering

G01 Lajes Field Ceiling Standards

http://www.wbdg.org/FFC/AF/AFIFS/G01_Lajes_Field_Ceiling_Standards.pdf

G02 Lajes Field Construction Site Standards

http://www.wbdg.org/FFC/AF/AFIFS/G02_Lajes_Field_Construction_Site_Standards.pdf

G03 Lajes Field Door and Window Sills Standards

http://www.wbdg.org/FFC/AF/AFIFS/G03_Lajes_Field_Door_Window_Sills_Standards.pdf

G04 Lajes Field Electrical, Mechanical and Plumbing

http://www.wbdg.org/FFC/AF/AFIFS/G04_Lajes_Field_Electrical_Mechanical_Plumbing.pdf

G05 Lajes Field Environmental

http://www.wbdg.org/FFC/AF/AFIFS/G05_Lajes_Field_Environmental.pdf

G06 Lajes Field Exterior Base Colors Standards

http://www.wbdg.org/FFC/AF/AFIFS/G06_Lajes_Field_Exterior_Base_Colors_Standards.pdf

G07 Lajes Field Fencing and Gates Standards

http://www.wbdg.org/FFC/AF/AFIFS/G07_Lajes_Field_Fencing_Gates_Standards.pdf

G08 Lajes Field Fire Protection

http://www.wbdg.org/FFC/AF/AFIFS/G08_Lajes_Field_Fire_Protection.pdf

G09 Lajes Field Geographically Separated Units (GSUs)

http://www.wbdg.org/FFC/AF/AFIFS/G09_Lajes_Field_Geographically_Separated_Units.pdf

G10 Lajes Field Gutters and Downspouts

http://www.wbdg.org/FFC/AF/AFIFS/G10_Lajes_Field_Gutters_Downspouts.pdf

G11 Lajes Field Interior Signs

http://www.wbdg.org/FFC/AF/AFIFS/G11_Lajes_Field_Interior_Signs.pdf

G12 Lajes Field Interior Wall Finishes Standards

http://www.wbdg.org/FFC/AF/AFIFS/G12_Lajes_Field_Interior_Wall_Finishes_Standards.pdf

G13 Lajes Field Lighting, Power and Communication

http://www.wbdg.org/FFC/AF/AFIFS/G13_Lajes_Field_Lighting_Power_Communication.pdf

G14 Lajes Field Plumbing Fixtures and Equipment Standards

http://www.wbdg.org/FFC/AF/AFIFS/G14_Lajes_Field_Plumbing_Fixtures_Equipment_Standards.pdf

G15 Lajes Field Road Pavements

http://www.wbdg.org/FFC/AF/AFIFS/G15_Lajes_Field_Road_Pavements.pdf

G16 Lajes Field Pest Prevention

http://www.wbdg.org/FFC/AF/AFIFS/G16_Lajes_Field_Pest_Prevention.pdf

G17 Lajes Field Liquid Fuels

http://www.wbdg.org/FFC/AF/AFIFS/G17_Lajes_Field_Liquid_Fuels.pdf

G18 Lajes Field Plant Catalogue

http://www.wbdg.org/FFC/AF/AFIFS/G18_Lajes_Field_Plant_Catalogue.pdf

G19 Lajes Field Soffit System, Vents, Louvers and Pipes

http://www.wbdg.org/FFC/AF/AFIFS/G19_Lajes_Field_Soffit_System_Vents_Louvers_Pipes.pdf