

DOVER AIR FORCE BASE INSTALLATION FACILITIES STANDARDS (IFS)



Installation Elements



Site Development



Facilities Exteriors

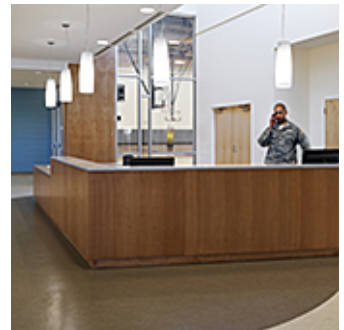

Facilities Interiors

APPROVED FOR PUBLIC RELEASE; DISTRIBUTION UNLIMITED

Signature Field

Dover Air Force Base IFS

Table of Contents

A. OVERVIEW	5	B03.2.3. Preserves	
A01. Facility Hierarchy	6	B03.2.4. Perimeter Fence	
A02. Facility Quality	6	C. SITE DEVELOPMENT	29
A03. Facility Districts	6	C01. Site Design	29
B. INSTALLATION ELEMENTS	8	C01.1. Site Design Considerations	29
B01. Comprehensive Planning	8	C01.2. Building Orientation	30
B01.1. Installation Development Plan (IDP)	8	C02. Utilities	31
B01.1.1. IFS Requirements and Documents		C02.1. Utility Components	32
B01.1.2. Brief History of Base		C03. Parking Areas	33
B01.1.3. Future Development		C03.1. Configurations and Design	33
B02. Street Envelope Standards	13	C03.1.1. Paving and Striping	
B02.1. Hierarchy of Streets	14	C03.1.2. Curbing	
B02.1.1. Arterial Streets		C03.1.3. Internal Islands and Medians	
B02.1.2. Collector Streets		C03.2. Parking Structures	36
B02.1.3. Local Streets		C03.3. Connectivity	36
B02.1.4. Special Routes		C04. Stormwater Management	36
B02.2. Hierarchy of Intersections	18	C04.1. Stormwater Requirements	37
B02.2.1. Arterials		C05. Sidewalks, Bikeways and Trails	37
B02.2.2. Arterial/Collector		C05.1. Circulation and Paving	38
B02.2.3. Collectors		C05.1.1. Ramps and Stairs	
B02.2.4. Special Intersections		C05.1.2. Lighting	
B02.2.5. Street Frontage Requirements		C06. Landscape	40
B02.2.6. Sight Lines		C06.1. Climate-based Materials	40
B02.3. Street Elements	20	C06.1.1. Landscape Design Concept	
B02.3.1. Paving		C06.1.2. Xeriscape Design Principles	
B02.3.2. Curb and Gutter		C06.1.3. Minimizing Water Requirements	
B02.3.3. Utility Service Elements		C06.1.4. Plant Material Selection	
B02.3.4. Traffic Signs		C06.1.5. Water Budgeting (Hydrozones)	
B02.3.5. Street Lighting		C06.1.6. Base Entrance Landscaping	
B02.3.6. Other		C06.1.7. Streetscape Landscaping	
B03. Open Space / Public Space	22	C06.1.8. Pedestrian Circulation Landscaping	
B03.1. Plazas, Monuments and Static Displays	23	C06.1.9. Parking Lot Landscaping	
B03.1.1. Paved Plazas		C06.1.10. Screen/Accent Landscaping	
B03.1.2. Sculptures, Markers and Statuary		C06.1.11. Other	
B03.1.3. Static Display of Aircraft		C07. Site Furnishings	46
B03.2. Grounds and Perimeters	25	C07.1. Furnishings and Elements	46
B03.2.1. Parade Grounds			
B03.2.2. Parks			

Table of contents continued

C07.2. Site Furnishings Products, Materials / Color ..	47	D03.3.4. Thermal Shading	
C07.2.1. Barbeque Grills		D03.3.5. Renewable Heating/Cooling	
C07.2.2. Benches		D03.3.6. Solar Photovoltaic System	
C07.2.3. Bike Racks		D03.3.7. Solar Thermal System	
C07.2.4. Bike Lockers		D04. Building Entrances	81
C07.2.5. Bollards		D04.1. Primary Entrances	82
C07.2.6. Bus Shelters		D04.2. Secondary Entrances	82
C07.2.7. Drinking Fountains		D05. Wall Systems	83
C07.2.8. Dumpster Enclosures / Gates		D05.1. Hierarchy of Materials	84
C07.2.9. Fencing		D05.2. Layout, Organization and Durability	84
C07.2.10. Flagpoles		D05.3. Equipment, Vents and Devices	85
C07.2.11. Lighting – Landscape / Accent		D05.4 Wall Systems Materials	85
C07.2.12. Litter and Ash Receptacles		D05.4.1. Flat Metal Panels	
C07.2.13. Picnic Tables		D05.4.2. Brick Veneer	
C07.2.14. Planters – Free Standing		D05.4.3. Architectural Precast	
C07.2.15. Play Equipment		D05.4.4. Stucco Over Sheathing	
C07.2.16. Screen Walls		D05.4.5. Curtain Wall	
C07.2.17. Tree Grates		D05.4.6. Cast-in Place Concrete	
C07.2.18. Other		D05.4.7. Tilt-up Concrete	
C08. Exterior Signs	60	D05.4.8. Ribbed Metal Sheeting	
C08.1. Colors and Types	60	D05.4.9. EIFS	
C08.1.1. Materials and Color Specifications		D05.4.10.GFRC	
C08.1.2. Installation and Gate Identification Signs		D05.4.11.Concrete Block	
C08.1.3. Building Identification Signs		D05.4.12. Fiber Cement Siding	
C08.1.4. Traffic Control Devices (Street Signs)		D05.4.13. Other	
C08.1.5. Directional and Wayfinding Signs		D06. Doors and Windows	91
C08.1.6. Informational Signs		D06.1. Types	92
C08.1.7. Motivational Signs		D06.2. Layout and Geometry	92
C08.1.8. Parking Lot Signs		D06.3. Glazing and Shading	92
C08.1.9. Regulatory Signs		D06.4. Hardware	92
C08.1.10. Other		D06.5. Doors and Windows Materials	93
C09. Lighting	68	D06.5.1. Anodized Aluminum	
C09.1. Fixtures and Lamping	68	D06.5.2. Hollow Metal	
C09.2. Light Fixture Types	69	D06.5.3. Aluminum-clad Wood	
C09.2.1. Street Lighting		D06.5.4. Other	
C09.2.2. Parking Lot Lighting		D07. Roof Systems	95
C09.2.3. Lighted Bollards		D07.1. Roof Type and Form	96
C09.2.4. Sidewalk Lighting		D07.2. Roof Slope	96
C09.2.5. Walls / Stairs Lighting		D07.3. Parapets and Copings	96
C09.2.6. Other		D07.4. Color and Reflectivity	97
D. FACILITIES EXTERIORS	74	D07.5. Gutters, Downspouts, Scuppers, Drains	97
D01. Supporting the Mission	74	D07.6. Roof Vents and Elements	97
D02. Sustainability	74	D07.7. Clerestories and Skylights	98
D03. Architectural Features	75	D07.8. Vegetated Roof	98
D03.1. Orientation, Massing and Scale	76		
D03.2. Architectural Character	76		
D03.3. Details and Color	76		
D03.3.1. Climate-based Data			
D03.3.2. Natural Ventilation System			
D03.3.3. Thermal Mass			

Table of contents continued

D07.9. Roof Systems Materials	98	E04. Ceilings	126
D07.9.1. Standing Seam Metal		E04.1. Ceiling Materials	126
D07.9.2. Membrane Single-ply		E04.1.1. Exposed Framing (Roof / Floor Structure	
D07.9.3. Built-up Multi-ply		Above)	
D07.9.4. Concrete Tile		E04.1.2. Exposed Concrete	
D07.9.5. Clay Tile		E04.1.3. Grid and Acoustical Tile	
D07.9.6. Slate Shingles		E04.1.4. Gypsum Board	
D07.9.7. Vegetated System		E04.1.5. Metal Panels	
D07.9.8. Ribbed Metal Sheeting		E04.1.6. Wood	
D07.9.9. Composite Shingles		E04.1.7. Rapidly-Renewable Products	
D07.9.10. Other		E04.1.8. Other	
D08. Structural Systems	102	E05. Doors and Windows	132
D08.1. Systems and Layouts	103	E05.1. Doors and Windows and Frames Materials	132
D08.2. Structural Systems Materials	103	E05.1.1. Aluminum	
D08.2.1. Concrete		E05.1.2. Hollow Metal	
D08.2.2. Insulated Concrete Forming (ICF)		E05.1.3. Wood	
D08.2.3. Steel		E05.1.4. Other	
D08.2.4. Pre-Engineered Steel		E06. Casework Systems	135
D08.2.5. Masonry		E06.1. Casework Materials	136
D08.2.6. Heavy Timber		E06.1.1. Plastic Laminate	
D08.2.7. Light-gauge Steel		E06.1.2. Solid Polymer Surface	
D08.2.8. Lumber Framing		E06.1.3. Rapidly-Renewable Products	
D08.2.9. Other		E06.1.4. Metal	
D09. Mechanical, Electrical and Plumbing	106	E06.1.5 Other	
D09.1. Passive and Active Systems	107	E06.2. Countertop Materials	139
D09.2. Functionality and Efficiency	114	E06.2.1. Plastic Laminate	
E. FACILITIES INTERIORS	116	E06.2.2. Solid Polymer Surface	
E01. Building Configurations	117	E06.2.3. Natural Stone	
E01.1. Layout and Common Areas	117	E06.2.4. Cast Stone	
E01.1.1. Interior Design Process		E06.2.5. Metal	
E01.1.2. Codes and Regulations		E06.2.6 Other	
E01.2. Quality and Comfort	119	E07. Furnishings	141
E02. Floors	119	E07.1. Durability and Serviceability	141
E02.1. Floor Materials	119	E07.2. Accessories	141
E02.1.1. Prepared Slabs		E08. Interior Signs	141
E02.1.2. Natural Stone and Terrazzo		E08.1 Types and Color	141
E02.1.3. Quarry Tile		E08.2. Interior Signs Materials	142
E02.1.4. Ceramic Tile		E09. Lighting, Power and Communication	142
E02.1.5. Resilient Floor		E09.1. Functionality and Efficiency	142
E02.1.6. Carpet		E09.2. Types and Color	142
E02.1.7. Rapidly-Renewable Products		F. Appendices	143
E02.1.8. Other		G. Appendices	145
E03. Walls	124		
E03.1. Wall Materials	124		
E03.1.1. Concrete			
E03.1.2. Masonry			
E03.1.3. Ceramic Tile			
E03.1.4. Gypsum Board			
E03.1.5. Metal Panels			
E03.1.6. Wood Paneling			
E03.1.7. Rapidly-Renewable Products			
E03.1.8. Other			

A. OVERVIEW

Comply with Air Force Corporate Standards for Overview:

<http://afcfs.wbdg.org/index.html>

This Installation Facilities Standards (IFS) document is part of the Air Force Corporate Facilities Standards (AFCFS) program to assist bases in implementing and maintaining facilities standards as appropriate for efficient operations within the respective climate region. IFS fully replaces, consolidates and simplifies existing facilities standards documents, such as the Architectural Compatibility Plan (ACP) or ACGs, FEPs, etc., and organizes information using the same structure, or Table of Contents, as the AFCFS website.

IFS reflects the AFCFS' concepts of "Facility Hierarchy" (categorizing facilities into group numbers) and "Facility Quality" (assigning an appropriate level of quality to each group number) and applies these principles at the base level. Applicable DoD and Air Force criteria such as UFCs, AFIs, Memoranda, and UFGSs (Guide Specs) are referenced and linked within IFS to ensure the document is always current.

Navigating within this IFS is efficient and straightforward. Please use the interactive Table of Contents to locate subject matter, and click on the title of a section to access it. From any page, click on the "Back to Table of Contents" footer to return. Content is organized into 4 major sections: Installation Elements, Site Development, Facilities Exteriors and Facilities Interiors.

This IFS document begins as a fill-in PDF form, which is fully editable, and becomes a "living document" that can be regularly updated by base-level personnel following a format that is consistent across the Air Force. While the format is standardized, IFS content is customized for base operations and the local climate to ensure mission success while emphasizing reduced maintenance and reduced initial costs, life-cycle costs, energy use, and water use.

1. Conformance to Air Force Corporate Facilities Standards (AFCFS) and Installation Facilities Standards (IFS) are required by Air Force Instruction (AFI) 32-1023 and Air Force Memorandum. Please refer to the AFCFS website for links to documentation on current policy.
2. Requests to deviate from any installation facilities standards, that are Unified Facilities Criteria (UFC) requirements, will follow the process outlined in the AFCFS for UFC waivers and exemptions.
3. All Air Force designs including Non-Appropriated Funds (NAF) facilities are required to conform to AFCFS per Air Force Instruction (AFI) 32-1023; AFCFS will be used to formulate Installation Facilities Standards (IFS) per the AFI. The Base Civil Engineer (BCE) maintains and implements the IFS.
4. Please refer to the AFCFS website as a portal to reference materials and requirements documents for design and construction projects (via links). Specific references to current DoD memoranda and Air Force criteria are updated periodically to provide the most current guidance and requirements. Programming, design and contract documents should list "current edition" for all reference and requirements documents. The documents in force at the date of execution of the design and/or construction contract will be the governing version.
5. *Advanced Modeling Requirements:*
For all Air Force projects requiring advanced modeling, to include 3D visualization, Building Information Modeling (BIM), facility data, quantity take-off, geospatial, etc., follow the Army standards. Refer to USACE Minimum Model Matrix (M3) and Project Execution Plan (PxP) which outline required model uses. Refer to [CAD BIM Technology Center \(Contract Requirements\)](#) for more information on M3 and PxP.
6. Joint Bases will implement IFS under their Joint-Base designation with volume numbers for individual installations following the IFS Development Tool template. For example, for Joint Base Langley-Eustis, provide: Vol. 1 Langley AFB and Vol. 2 Fort Eustis.
7. References and Supplementary Documents listed in Appendix G are included in these Installation Facilities Standards by reference and are fully part of this document. Please refer to [Appendix G](#) for a listing of documents, which are available via hyperlink for viewing and downloading.
8. Installations outside the United States: Per UFC 1-200-01 DOD BUILDING CODE, 8 Oct 2019, "All construction outside of the United States is also governed by Status of Forces Agreements (SOFA), Host Nation Funded Construction Agreements (HNFA), and in some instances, Bilateral Infrastructure Agreements (BIA). Therefore, the acquisition team must ensure compliance with the most stringent of the UFC, the SOFA, the HNFA, and the BIA, as applicable." Refer to [Appendix G](#) for applicable agreements. "Use UFC 1-202-01 for design of host nation facilities that support military operations."
<https://www.wbdg.org/ffc/dod/unified-facilities-criteria-ufc/ufc-1-202-01>

Applicable N/A Large graphics do not apply

Applicable N/A Small graphics do not apply

A01. FACILITY HIERARCHY

Comply with AF Corporate Standards for Facility Hierarchy (and subsections):

<http://afcfs.wbdg.org/facility-hierarchy/index.html>

A02. FACILITY QUALITY

Comply with AF Corporate Standards for Facility Quality (and subsections):

<http://afcfs.wbdg.org/facility-quality/index.html>

A03. FACILITY DISTRICTS

Comply with AF Corporate Standards for Facility Districts (and subsections):

<http://afcfs.wbdg.org/facility-districts/index.html>

Image Tool 800 x 800

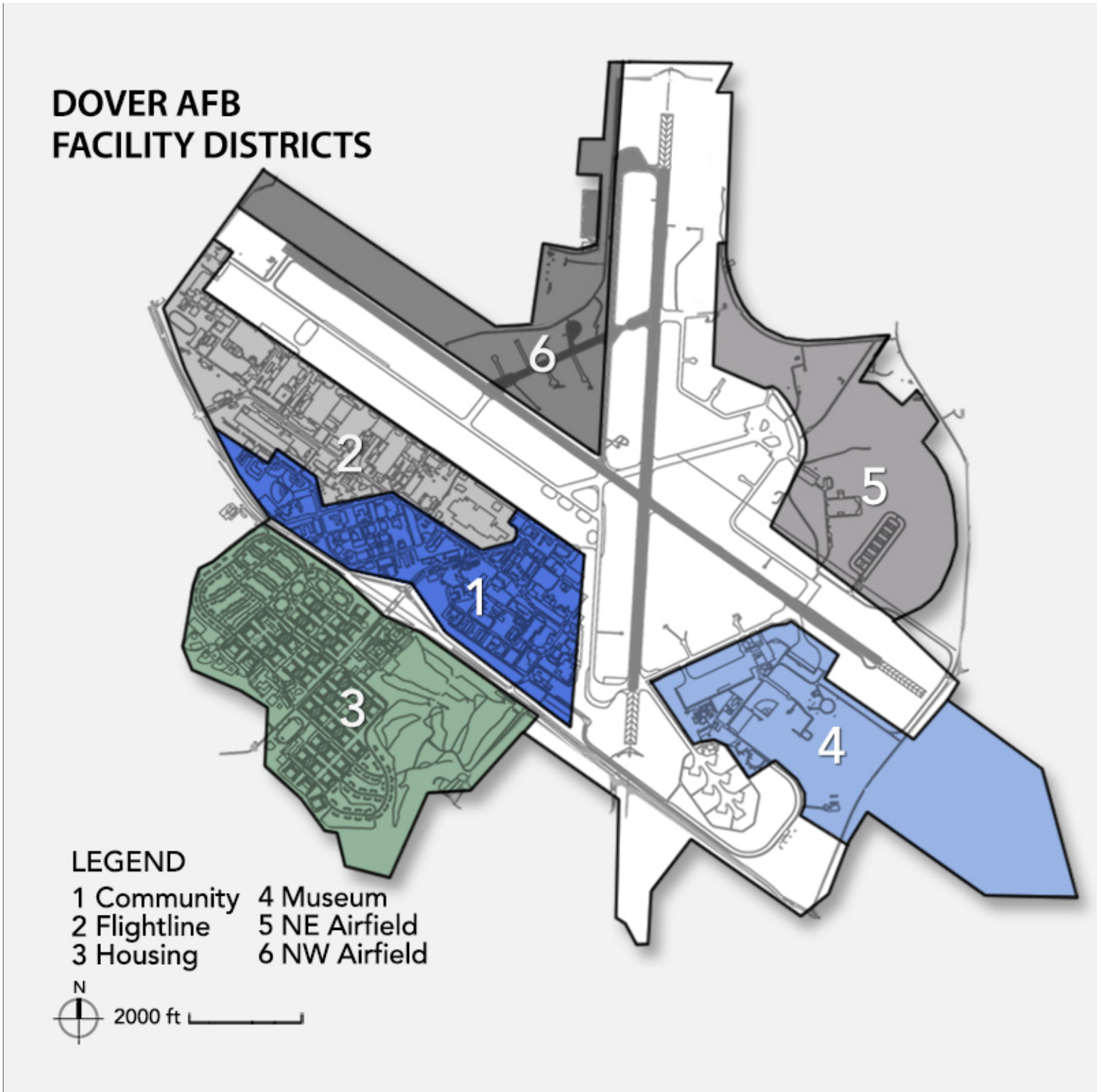

Note: Apply the base-wide standards in this IFS for Installation Elements, Site Development, Facilities Exteriors and Facilities Interiors (products, materials, color, etc.). Following application of the base-wide standards, refer to the Appendix and apply any additional requirements specifically related to the Facility District.

B. INSTALLATION ELEMENTS

Comply with Air Force Corporate Standards for Installation Elements:

<http://afcs.wbdg.org/installation-elements/index.html>

B01. COMPREHENSIVE PLANNING

Comply with Air Force Corporate Standards for Comprehensive Planning:

<http://afcs.wbdg.org/installation-elements/comprehensive-planning/index.html>

B01.1. Installation Development Plan (IDP)

Applicable N/A Select number of graphics / images (large: 800 px x 440 px) to insert 3

Image Tool 800 x 440

Applicable N/A Small graphics do not apply

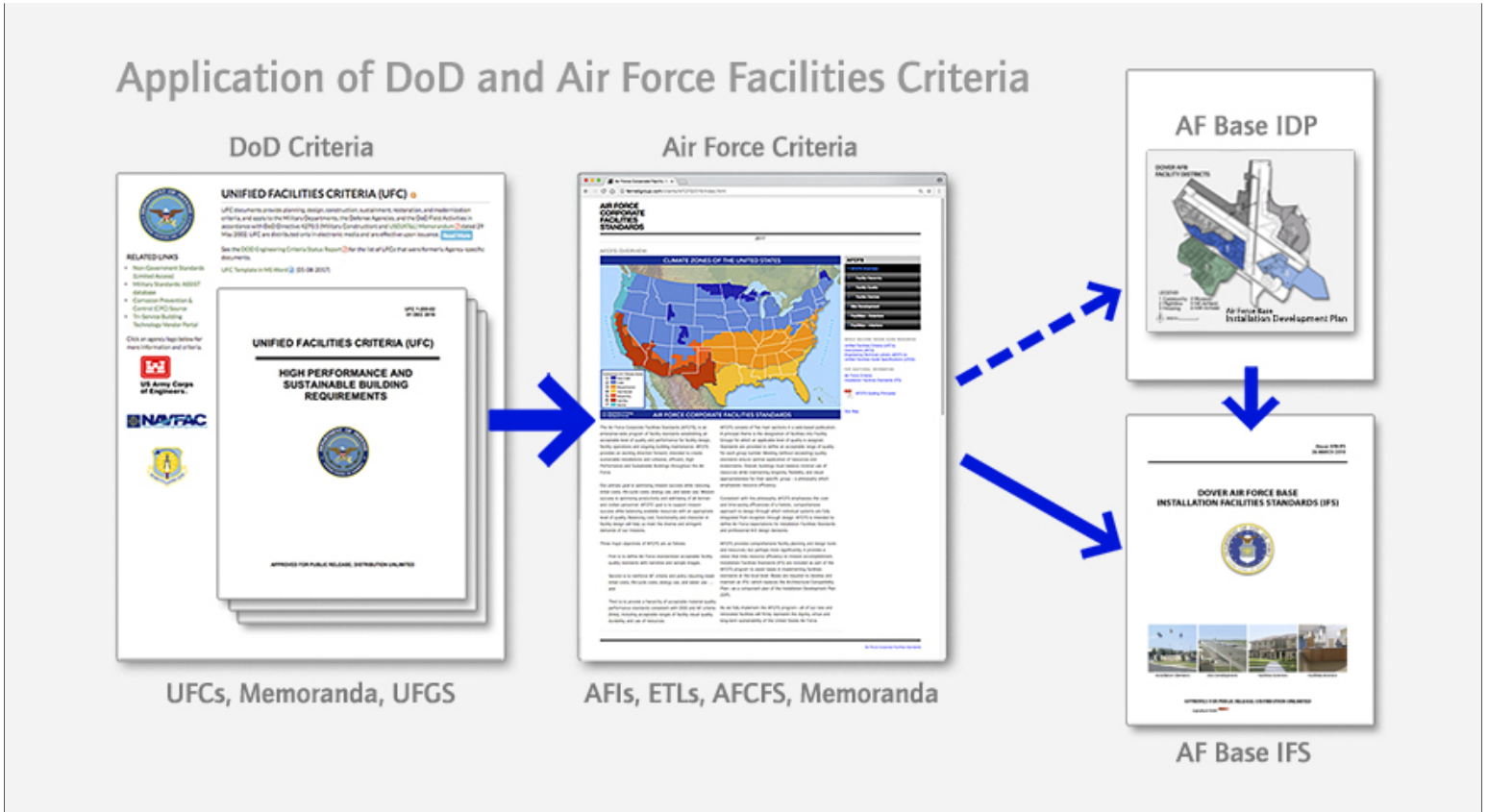

Department of Defense, Department of the Air Force and Air Force Base Criteria

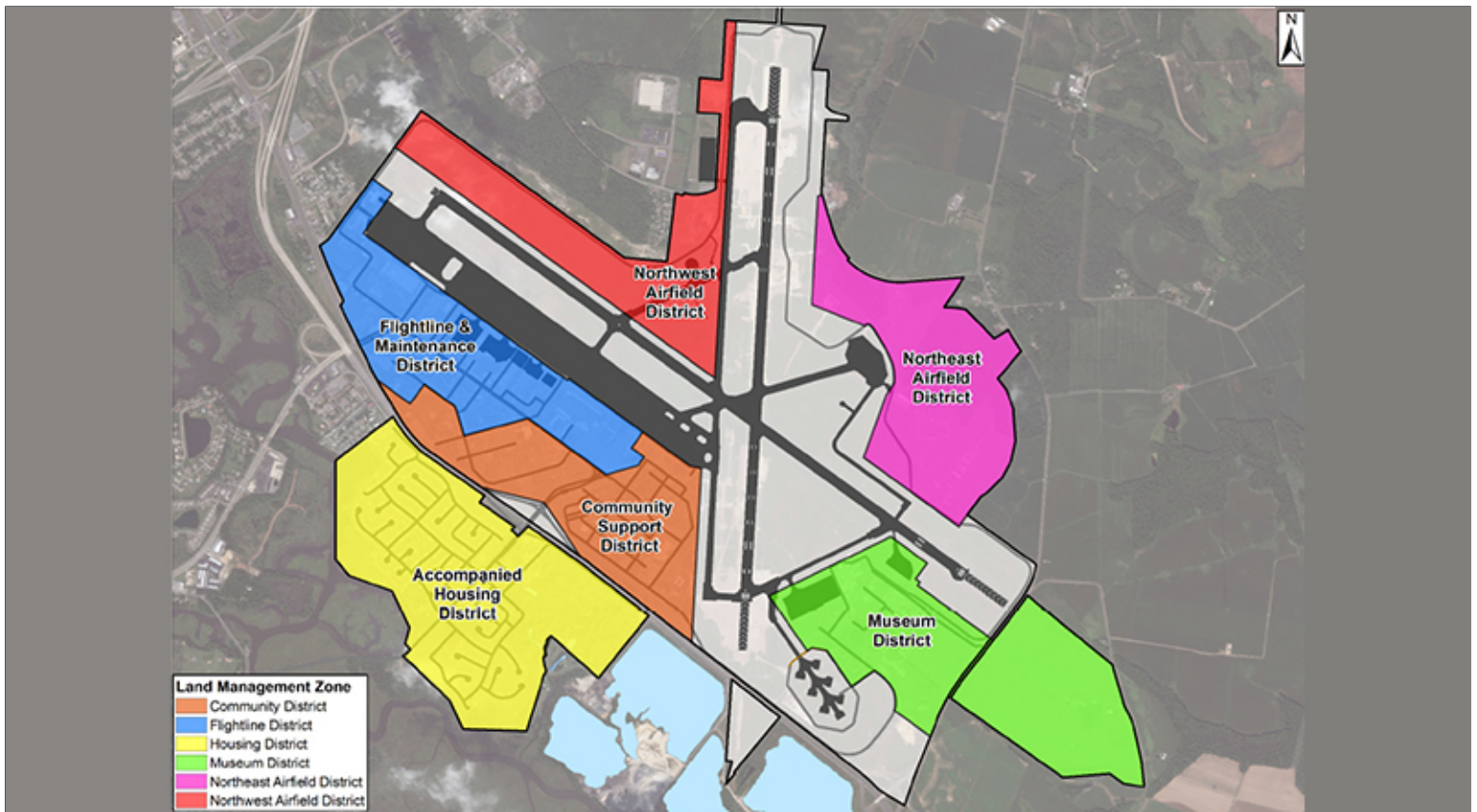

Land Management Zone Diagram



Vision Diagram as Depicted in the IDP

1. The Base Civil Engineer is responsible for developing, maintaining and implementing the installation's Comprehensive Planning documents and to ensure that the Installation Development Plan (IDP) is prepared, maintained, and implemented following AFI 32-7062.

B01.1.1. IFS Requirements and Documents

Applicable N/A Large graphics do not apply

Applicable N/A Small graphics do not apply

1. Maintain this Installation Facilities Standards (IFS) as a Component Plan of the base's Installation Development Plan (IDP).

B01.1.2. Brief History of Base

Applicable N/A Large graphics do not apply

Applicable N/A Select number of graphics / images (small: 250 px x 188 px) to insert 8

Image Tool 250 x 188



Dover Army Airfield Aerial Photo 1944



Headquarters 125th AAF Unit-Fighter



Track-side PRR Station Dover, Delaware



State of Delaware Historical Building



Dover AFB Flightline Support Facilities



Dover AFB Flightline



Local Historical Architecture



Aircraft Approach

The origins of Dover Air Force Base begin in March 1941 when the United States Army Air Corps indicates a need for the airfield as a training airfield and assumed jurisdiction over the municipal airport at Dover, Delaware. In March 1941, the construction of Municipal Airport, Dover Airdrome begins and the facility is opened on December 17, 1941. It is converted to an Army Air Corps airfield a few weeks after the December 7, 1941 attack on Pearl Harbor. It is renamed Dover Army Airbase on April 8, 1943; Dover Subbase on June 6, 1943 and Dover Army Airfield on February 2, 1944. With the establishment of the United States Air Force on September 18, 1947, the facility is renamed Dover Air Force Base on January 13, 1948. In 1948 the 436th Troop Carrier Wing is established and is redesignated the 436th Military Airlift Wing (MAW) on 27 December 1965. Assigned to Twenty-First Air Force, the wing is stationed at Dover AFB, Delaware, and flies C-124 Globemaster II, C-133 Cargomaster, C-141 Starlifter, and C-5 Galaxy aircraft. The wing is redesignated the 436th Airlift Wing (AW) on 1 December 1991 and flies C-5 Galaxy and C-17 Globemaster III aircraft. As the active duty military host unit at Dover Air Force Base, the 436th Airlift Wing serves and provides command and staff supervision, along with support functions, for assigned airlift providing worldwide movement of outsized cargo and personnel on scheduled, special assignment, exercise and contingency airlift missions. Dover AFB operates the largest and busiest air freight terminal in the Department of Defense and operates The Charles C. Carson Center for Mortuary Affairs, DoD's largest joint-service mortuary facility and the only one located in the continental United States. The base continues to successfully maintain and operate C-5 Galaxy and C-17 Globemaster III aircraft, and the "Eagle Wing" flies hundreds of missions throughout the world and provides 25 percent of the Nation's strategic airlift capability, projecting global reach to over 100 countries around the globe.

B01.1.3. Future Development

Applicable N/A Select number of graphics / images (large: 800 px x 440 px) to insert 2

Image Tool 800 x 440

Applicable N/A Select number of graphics / images (small: 250 px x 188 px) to insert 2

Image Tool 250 x 188



Demo Plan for ADP 6

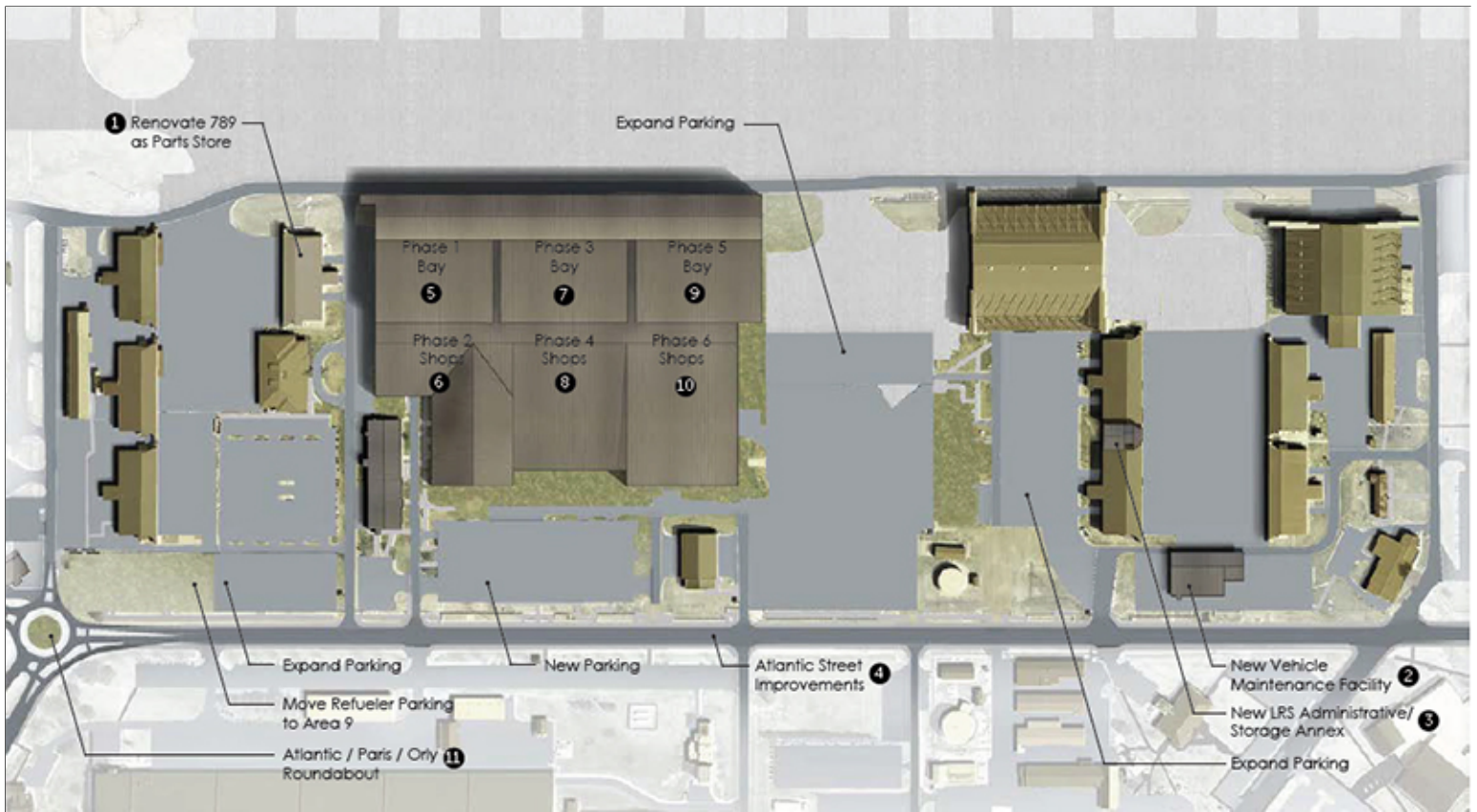

Preferred Alternative for ADP 6



Key Planning Factors Diagram



Flightline Considerations

1. Follow AFI 32-7062 for Air Force Comprehensive Planning, the Comprehensive Planning Process, Comprehensive Planning Requirements, and Geospatial Mapping.

2. Address all future development under the Installation Development Plan (IDP).

B02. STREET ENVELOPE STANDARDS

Comply with Air Force Corporate Standards for Installation Elements:

<http://afcs.wbdg.org/installation-elements/index.html>

Comply with AF Corporate Standards for Street Envelope Standards:

<http://afcs.wbdg.org/installation-elements/street-envelope-standards/index.html>

B02.1. Hierarchy of Streets

Applicable N/A Large graphics do not apply

Applicable N/A Select number of graphics / images (small: 250 px x 188 px) to insert 2

Image Tool 250 x 188



Hierarchy of Streets

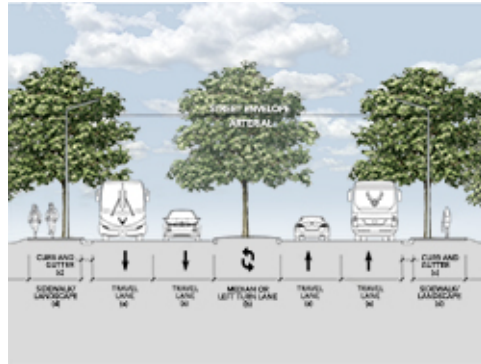

Street Envelope Section

1. Develop and evolve a hierarchical transportation network of arterial, collector and local streets following UFC 3-201-01 and its industry references.
2. Provide consistent functionality throughout the installation and a level of visual quality relating to the adjacent Facility Group number.
3. Routes along facilities in Group 1 may have materials, finishes and features with a higher visual quality than Groups 2, 3 and 4. Reduce maintenance requirements by installing highly durable materials and finishes in routes along Group 3 industrial facilities.
4. Special routes may have a visual quality comparable to those along facilities in Group 1.
5. Create and maintain arterials with two lanes of traffic in each direction with landscaped or paved medians as applicable to the local climate and adjacent facility group designation / land use.
6. Minimize stops and turns along arterials. Eliminate on-street parking along arterials and collector streets.
7. Connect arterials to local streets with appropriately scaled collector streets.
8. Provide appropriate landscape setbacks and pedestrian buffers along all streets.
9. Minimize and consolidate curb cuts along streets.
10. Ensure access for emergency and service vehicles.
11. Define bicycle traffic routes in the Installation Development Plan or its applicable component plans.
12. Provide illustrations in the Installation Facilities Standards (IFS) to include street cross-sections and plans for every type of street specified on the installation. At a minimum provide dimensions for vehicular traffic-lanes, curb radii, medians, bike lanes, pedestrian buffers, sidewalks, crosswalks, tree planting areas, and on-street parking configurations.
13. Define appropriate force protection features, site furnishings, signs, lighting, utilities, and paving in the IFS.

B02.1.1. Arterial Streets

Applicable N/A Select number of graphics / images (large: 800 px x 440 px) to insert 1

Image Tool 800 x 440

Applicable N/A Select number of graphics / images (small: 250 px x 188 px) to insert 3

Image Tool 250 x 188

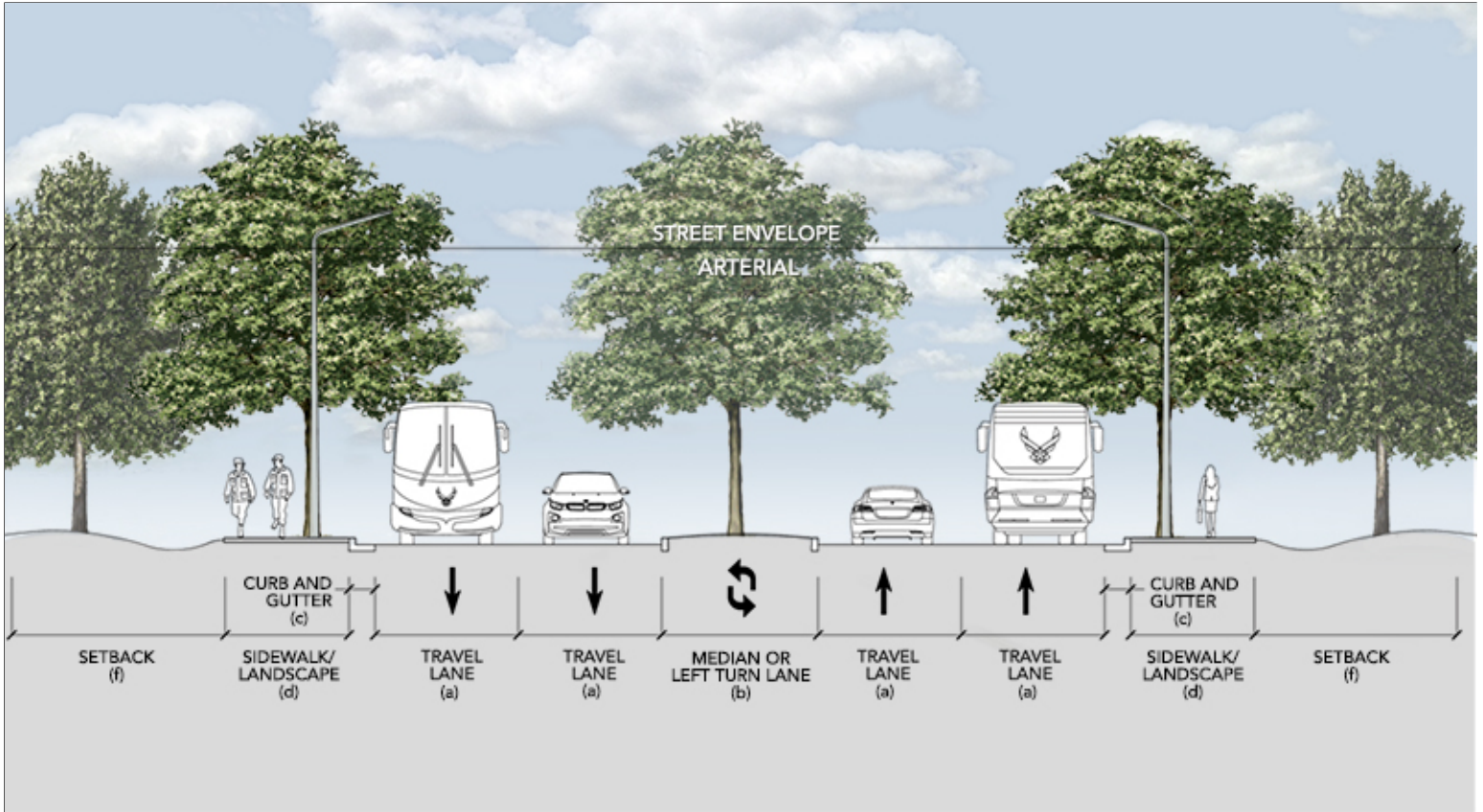

Travel Lane (a): 12' Median (b): 12' Curb and Gutter (c): 2' Sidewalk / Landscape (d): 12' Setback (f): Min. 35' or per AT

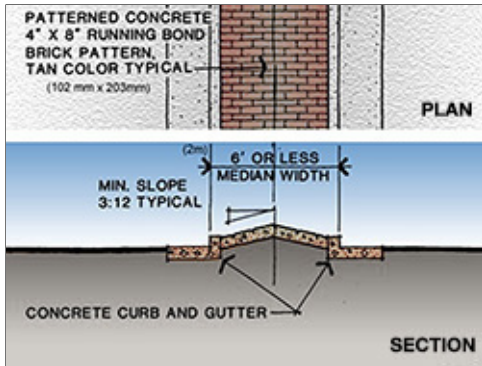

Paved Median

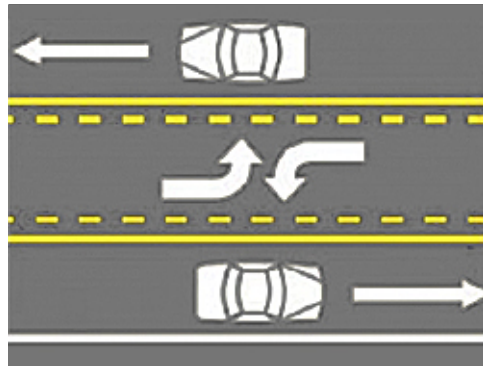

Left Turn Lane



Landscaped Median

1. Continue to maintain the streets currently designated as aerial streets in future development.

B02.1.2. Collector Streets

Applicable N/A Select number of graphics / images (large: 800 px x 440 px) to insert 1

Image Tool 800 x 440

Applicable N/A Select number of graphics / images (small: 250 px x 188 px) to insert 2

Image Tool 250 x 188



Travel Lane (a): 12' Median (b): N/A Curb and Gutter (c): 2' Landscape (d): 10' Sidewalk (e): 6' Setback (f): Min. 35' or per AT



Two-way Traffic



Typical Street Landscape

1. Due to frequent traffic stops, maintain low speed limits on collector streets.
2. Provide sidewalks on at least one side of collector streets. Buffers are preferred but not required on collector streets.
3. On street parking may be allowed on one side where secondary roads are over 28 feet wide but not less than 34 feet wide. Parking will not interfere with intersections or traffic flow.

B02.1.3. Local Streets

Applicable N/A Select number of graphics / images (large: 800 px x 440 px) to insert 1

Image Tool 800 x 440

Applicable N/A Select number of graphics / images (small: 250 px x 188 px) to insert 1

Image Tool 250 x 188

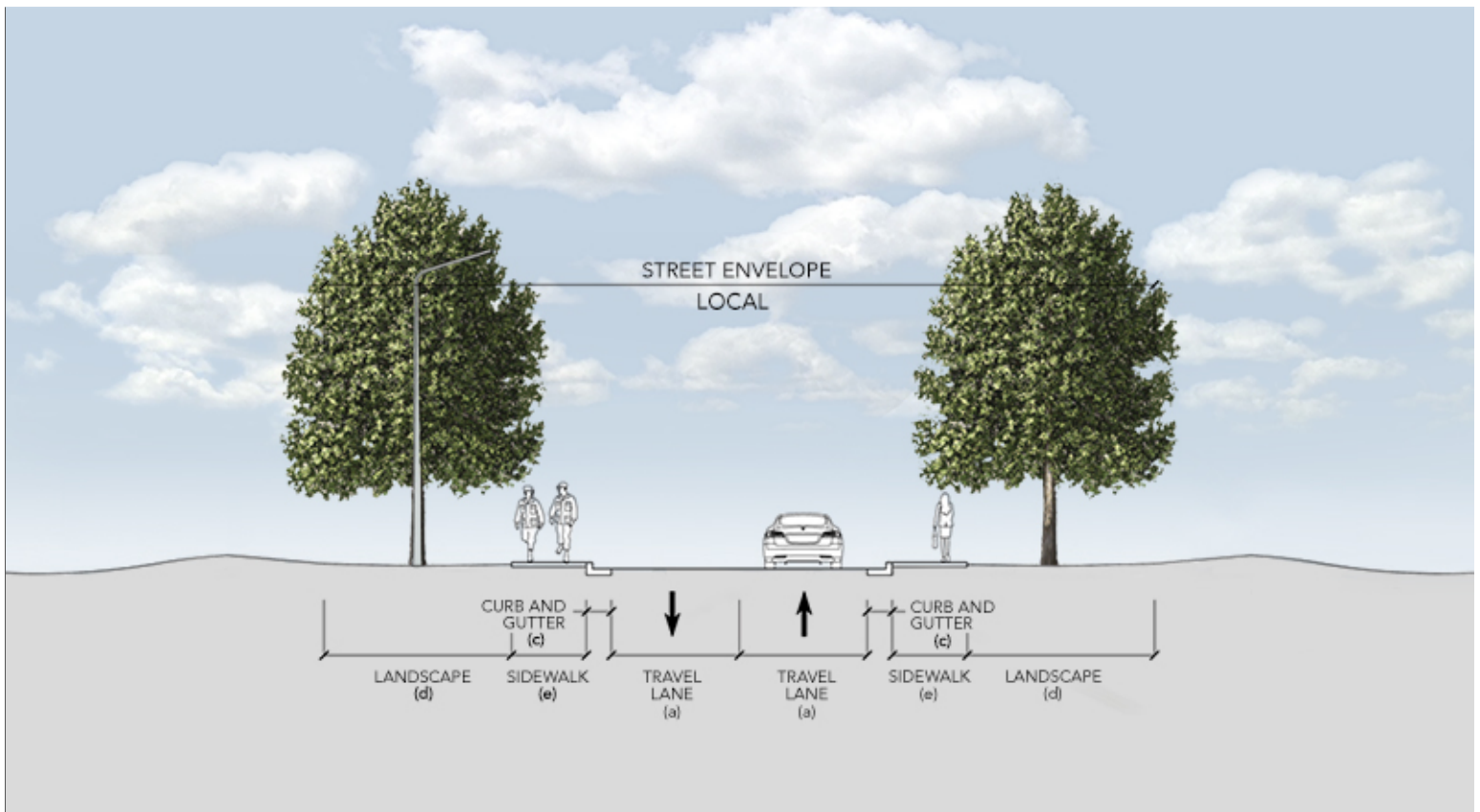

Travel Lane (a): 11' Median (b): N/A Curb and Gutter (c): 1.5' Landscape (d): 15' Sidewalk (e): 6'



Group 4 Streetscape

1. Due to frequent traffic stops, maintain low speed limits on local streets.
2. Provide sidewalks on at least one side of collector streets. Buffers are preferred but not required on collector streets.
3. On street parking may be allowed on one side where secondary roads are over 28 feet wide but not less than 34 feet wide. Parking will not interfere with intersections or traffic flow.
4. Cul-de-sacs are to only be used in the military housing area. The minimum radius for cul-de-sacs will be 50'.

B02.1.4. Special Routes

Applicable N/A Large graphics do not apply

Applicable N/A Select number of graphics / images (small: 250 px x 188 px) to insert 2

Image Tool 250 x 188



Special Route Streetscape



Special Route Features

1. Develop all special routes consistently with those adjacent to Group 1 facilities.

B02.2. Hierarchy of Intersections

Applicable N/A Large graphics do not apply

Applicable N/A Select number of graphics / images (small: 250 px x 188 px) to insert 1

Image Tool 250 x 188



Typical T Intersection

1. Provide a hierarchy of intersections to include arterial, arterial-collector, collector, collector-local and local following UFC 3-201-01 and its industry references.

2. Passive systems such as traffic circles are preferred to active systems such as signalized intersections. Aggressively pursue passive systems to lower maintenance requirements and reduce energy use.

3. Use a level of visual quality for an intersection equal to the quality found in the related streetscape, which corresponds to the adjacent Facility Group number.

B02.2.1. Arterials

Applicable N/A Large graphics do not apply

Applicable N/A Small graphics do not apply

1. Develop arterial intersections consistently with the adjacent facility group designation.

B02.2.2. Arterial/Collector

Applicable N/A Large graphics do not apply

Applicable N/A Small graphics do not apply

1. Develop arterial/collector intersections consistently with the adjacent facility group designation.

B02.2.3. Collectors

Applicable N/A Large graphics do not apply

Applicable N/A Small graphics do not apply

1. Develop collector intersections consistently with the adjacent facility group designation.

B02.2.4. Special Intersections

Applicable N/A Large graphics do not apply

Applicable N/A Small graphics do not apply

1. Develop all special intersections consistently with those adjacent to Group 1 facilities.

B02.2.5. Street Frontage Requirements

Applicable N/A Large graphics do not apply

Applicable N/A Select number of graphics / images (small: 250 px x 188 px) to insert 2

Image Tool 250 x 188



Group 1 Detached Sidewalk



Group 4 Attached Sidewalk

1. Consistently maintain open space buffers following B03.2.3. Preserves.
2. Refer to C06.1.7. Streetscape Landscaping for planting and screen wall requirements along street frontage.

B02.2.6. Sight Lines

Applicable N/A Large graphics do not apply

Applicable N/A Small graphics do not apply

1. Provide adequate sight lines for an effective and safe traffic operation per American Association of State Highway and Transportation Officials (AASHTO) standards and local municipality guidelines.

B02.3. Street Elements

Applicable N/A Large graphics do not apply

Applicable N/A Small graphics do not apply

1. Emulate the streetscape area's pre-development hydrology using passive and active design features to help sustain the adjacent regionally appropriate landscape. Coordinate with the base Stormwater Management Plan.
2. Employ systems, materials and techniques to maximize streetscape sustainability. Consider permeable paving and reflectivity of surfaces appropriate for the local climate.
3. Install at-grade curbing and/or raised-profile curb and gutter as applicable to direct stormwater to bioswales and rain gardens as source water for vegetation. Do not paint concrete curbing.
4. Provide all on-site utility service lines and equipment below grade when adjacent to Facility Group 1. In routes along Group 2, 3 and 4, when mounting elements such as utility cabinets, communications equipment and water valves above grade is unavoidable, paint these consistently and provide visual screening following Installation Facilities Standards (IFS).
5. Provide traffic control devices including access control point/entry control facility signs, speed limit signs and street name signs following the current edition of the Manual on Uniform Traffic Control Devices (MUTCD) per UFC 3-120-01.

6. Crosswalk markings must follow the MUTCD for Streets and Highways, current edition. Provide white markings that define the edges of the crosswalk or a tone of lines defining the area of the crosswalk consistent with common practices found in the adjacent municipality.

7. Follow UFC 3-120-01 for directional and wayfinding signs and address both vehicular and pedestrian traffic.

8. Reduce energy consumption and reduce maintenance requirements by providing street lighting only when functionally required to ensure safety and to address antiterrorism following UFC 4-010-01. Ensure the quality and quantities of lighting and fixtures are appropriate for the adjacent Facility Group number.

9. 1. Fire hydrants will be painted the Bald Eagle Brown color. TUI will paint fire hydrant bonnets the appropriate color based on flow capacity and actual flow tests in accordance with NFPA 291, "Fire Flow and Marking of Hydrants".

B02.3.1. Paving

Applicable N/A Large graphics do not apply

Applicable N/A Small graphics do not apply

1. The use of State of Delaware Department of Transportation (DelDOT) materials and mix designs for graded aggregate base, intermediate and wearing surface courses of hot-mix hot-laid asphalt concrete may be permitted if they comply with the respective UFGS criteria.

2. Pavement design must comply with UFC 3-250-01. Ensure appropriate analysis and design of subgrade conditions to promote low maintenance, high performance pavements. Apply all applicable best practices from Appendix B of the UFC.

3. Materials will be specified in accordance with UFC 3-250-01 and must conform to requirements set forth in the Unified Facility Guide Specifications (UFGS) for concrete and bituminous pavement.

B02.3.2. Curb and Gutter

Applicable N/A Large graphics do not apply

Applicable N/A Select number of graphics / images (small: 250 px x 188 px) to insert 2

Image Tool 250 x 188

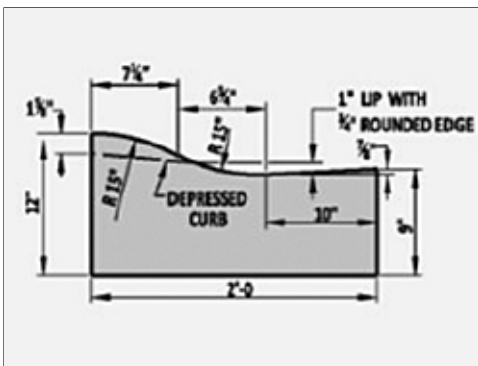

Type 2 Curb

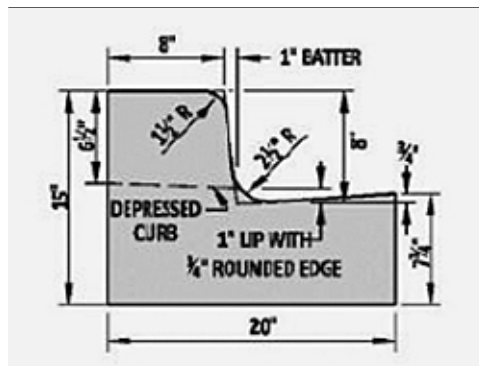

Type 3 Curb

1. Continuous concrete curbs will be provided at paved roads and parking areas adjacent to Group 1, Group 2 and Group 4 facilities.

2. Integral concrete curb and gutter will be used at areas with drainage (asphalt sloped towards curb). A header curb without gutter will be allowed in areas if adjacent asphalt is sloped away.

3. A minimum standard curb height of 6 inches will be consistently maintained. "Rolled" mountable curbs are allowed in Facility Group 4.

B02.3.3. Utility Service Elements

Applicable N/A Large graphics do not apply

Applicable N/A Small graphics do not apply

1. Provide all utility service lines below grade when streets are adjacent to Facility Group 1; when mounting elements (such as utility cabinets, communications equipment and water valves) above grade is unavoidable, paint these consistently and provide visual screening following Site Development, Landscaping.

2. Overhead service lines along streets adjacent to Facility Groups 2, 3 and 4 are discouraged.

B02.3.4. Traffic Signs

Applicable N/A Large graphics do not apply

Applicable N/A Small graphics do not apply

1. Refer to Exterior Signs, Colors and Types for Traffic Control Devices, which includes signs.

2. For Regulatory and Warning type signage and roadway markings, signals, crosswalks, temporary traffic control, etc., comply with US Department of Transportation Federal Highway Administration Manual of Uniform Traffic Control Devices (MUTCD) and the DoD Supplement to the MUTCD. Guide Sign faces and other sign faces (such as handicap and reserved parking signs, etc.) will be as required by UFC 3-120-01, Paragraph 2.18.2 Standard Brown paint (ISCC-NBS, Color Designation 56 String Brown, National Park Service Brown, Ink: PMS 469).

B02.3.5. Street Lighting

Applicable N/A Large graphics do not apply

Applicable N/A Small graphics do not apply

1. Refer to the Lighting section for appropriate applications along streets.

B02.3.6. Other

Applicable N/A Large graphics do not apply

Applicable N/A Small graphics do not apply

Not Applicable

B03. OPEN SPACE / PUBLIC SPACE

Comply with Air Force Corporate Standards for Installation Elements:

<http://afcfs.wbdg.org/installation-elements/index.html>

Comply with AF Corporate Standards for Open Space / Public Space:

<http://afcfs.wbdg.org/installation-elements/open-space-public-space/index.html>

B03.1. Plazas, Monuments and Static Displays

Applicable N/A Large graphics do not apply

Applicable N/A Select number of graphics / images (small: 250 px x 188 px) to insert 4

Image Tool 250 x 188



Group 1 Pavilion



Group 4 Pavilion



Group 3 Pavilion



Group 2 Pavilion

1. Natural features and culturally or historically significant features or events may be recognized and acknowledged with physical elements such as plazas, monuments and static displays. However, limit these elements on the base to ensure judicious use of resources and to reduce ongoing maintenance requirements.
2. Design highly durable plazas, monuments and static displays with a level of quality comparable to Facility Group 1.
3. Link plazas, monuments and static displays to the pedestrian circulation system. Install landscaping, site furnishings and lighting appropriate for the application and local climate following Installation Facilities Standards (IFS).
4. Select systems, products and materials for paving, walls, and structures following IFS.

B03.1.1. Paved Plazas

Applicable N/A Large graphics do not apply

Applicable N/A Select number of graphics / images (small: 250 px x 188 px) to insert 1

Image Tool 250 x 188



Group 2 Plaza

1. Mitigate heat island by providing high-albedo, shaded plazas. Permeable pavers will be used on all plazas and courtyards in Facility Groups 1 and 2; use pervious concrete in Groups 3 and 4. The designer will incorporate appropriate expansion and construction joints.

2. Pavers will match the color of pavers used on adjacent sidewalks using base standard range of Earth tone colors. Bricks used on plazas will typically be 4" x 8" size.

B03.1.2. Sculptures, Markers and Statuary

Applicable N/A Large graphics do not apply

Applicable N/A Small graphics do not apply

1. Relate new sculpture, markers and statuary to the base's architectural design theme. Generally limit these elements to frequently used locations adjacent to Facility Group 1 and highly traveled community pedestrian spaces.

2. Consider entry gates as possible sites for new displays.

3. All proposed memorials will follow AFI 36-3108 and be limited to highly deserving individuals or groups as deemed appropriate by the installation leadership. Living memorials (tree plantings / etc.) are discouraged due to added maintenance requirements.

4. When sculpture requires a base, match the materials and / or color palette of adjacent buildings.

5. Use direct or indirect lighting to accentuate features or enhance an intended effect.

6. Ensure that all sculpture, markers and statuary are honorable and inspiring, provide a sense of place, positively contribute to the base's visual quality, and encourage pride for the community and the US Air Force.

B03.1.3. Static Display of Aircraft

Applicable N/A Large graphics do not apply

Applicable N/A Select number of graphics / images (small: 250 px x 188 px) to insert 2

Image Tool 250 x 188



Ground-mounted Display



Post-mounted Display

1. Follow IFS base-wide standards for all elements of the display area with specific attention to traffic sight lines, pedestrian circulation, site furnishings, signs, and lighting. Address requirements for the Facility District as well.
2. Generally locate concrete base/foundation structures for static displays below grade.
3. At static displays where pedestrian paths are provided, a minimum of one trash receptacle and one bench will be provided. Receptacle and bench design must conform to IFS requirements.

B03.2. Grounds and Perimeters

Applicable N/A Large graphics do not apply

Applicable N/A Select number of graphics / images (small: 250 px x 188 px) to insert 1

Image Tool 250 x 188

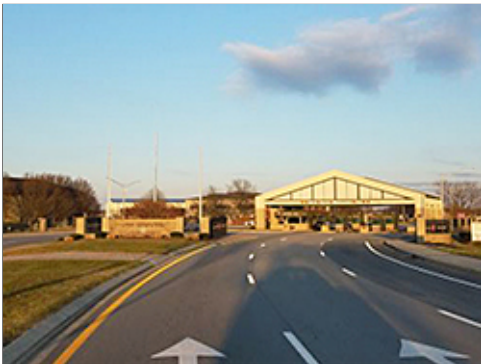

Perimeter Fence at Gate

1. Provide formal spaces for parade and review functions, recreational areas and parks following the base's Installation Development Plan (IDP) and Installation Facilities Standards (IFS). Refer to the Site Furnishings topic for additional information.
2. Maintain preservation areas following the IDP and IFS.
3. Comply with UFC 4-010-01 DoD Minimum Antiterrorism Standards for Buildings and UFC 4-022-03 Security Fences and Gates for all elements associated with the base's gates and perimeter fence.

4. Identify and describe base-wide utility corridors in the IDP.

5. Base-wide utility infrastructure will be inconspicuous. Bury utility service lines below grade when adjacent to Facility Group 1 and when economically feasible for Facility Groups 2, 3 and 4. When service lines are located above grade, create an ordered, coordinated appearance.

6. Follow the requirements of this IFS regarding all utility structures and service lines located above grade that visually impact the installation.

7. Where screening of utility equipment and structures is provided, allow adequate and proper clearance for safety and maintenance.

8. Reduce visual clutter and visual impact of the following items through a combination of careful placement, screen walls, landscaping and painting:

- Electrical switch-stations.
- Sewage lift stations.
- Water well pumps, storage tanks and/or related structures.
- Gas piping, meters and similar incidental items.
- Above ground fuel storage tanks.
- Any ground-mounted freestanding utility item exposed to view.

9. Larger structures such as electrical switch-stations, sewage lift stations, fuel storage tanks and mechanical/electrical equipment will be screened from view, using materials, forms, and colors in the screen walls which match those respective design elements present at adjacent buildings.

10. Paint above-ground equipment and associated components such as electrical piping or exposed plumbing lines dark bronze.

11. Maintain currently buried utility service lines as a visual asset.

12. Bury the following exposed above-grade items in future projects when economically feasible:

- Electrical power grid and service lines.
- Telephone lines.
- Cable TV lines.
- Communications lines.
- Exterior lighting service lines.
- Any similar system of above-ground lines serving the base.

13. Consolidate and enclose service utility lines in underground utility corridors when feasible. Create routes along the inside edge of parking lot islands.

B03.2.1. Parade Grounds

Applicable N/A Large graphics do not apply

Applicable N/A Small graphics do not apply

1. Follow UFC 3-201-02, Appendix B for the planning and design process and criteria for parade grounds.

2. Establish and maintain parade grounds only where there is a confirmed need and provide landscape materials appropriate for the locale following IFS.

3. Bleachers may be installed only when there is a documented requirement at parade grounds. Nonferrous metals that do not require painting or going maintenance are preferred. The Base Civil Engineer will determine quantities, sizes, and products on a case-by-case basis.

B03.2.2. Parks

Applicable N/A Large graphics do not apply

Applicable N/A Select number of graphics / images (small: 250 px x 188 px) to insert 2

Image Tool 250 x 188



Recreational Field



Park and Playground

1. Bleachers may be installed only when there is a documented requirement at parks and fields for recreational events. Follow guidance under Parade Grounds.
2. Picnic pavilions may be provided in parks where there is a documented need.

B03.2.3. Preserves

Applicable N/A Large graphics do not apply

Applicable N/A Small graphics do not apply

1. Preserve areas adjacent to runways, taxiways, aprons, golf course roughs, storage areas, antenna facilities, and ammunition storage areas, as open space.
2. Provide minimal maintenance with mowing as needed for controlling bird behavior for airfield safety, or eliminating fire hazards.

B03.2.4. Perimeter Fence

Applicable N/A Large graphics do not apply

Applicable N/A Select number of graphics / images (small: 250 px x 188 px) to insert 6

Image Tool 250 x 188

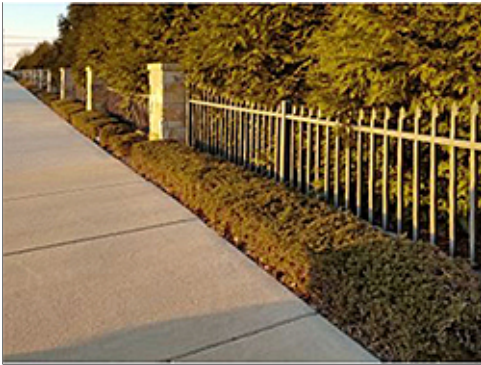

Group 1 Fence



Perimeter Fence



Group 3 Privacy Fence



Group 2 Security Wall



Group 2 CMU Screen Wall



Group 3 Remote Location

1. Design, install and maintain the base's perimeter fence following UFC 4-022-03.
2. Stringently comply with AT requirements following UFC 04-010-01 for all spaces adjacent to the base's perimeter fence and all gates.
3. Fencing, gates and other elements that are associated with the main gates will be a level of quality equivalent to Facility Group 1.
4. Maintain a positive visual quality along the traffic corridor on both sides of the main gates. Specifically address pedestrian access, circulation and common areas.

C. SITE DEVELOPMENT

Comply with Air Force Corporate Standards for Site Development:

<http://afcs.wbdg.org/site-development/index.html>

C01. SITE DESIGN

Comply with AF Corporate Standards for Site Design / NEPA:

<http://afcs.wbdg.org/site-development/site-design-nepa/index.html>

C01.1. Site Design Considerations

Applicable N/A Large graphics do not apply

Applicable N/A Small graphics do not apply

1. Collect documentation to validate approvals and completion of the NEPA process.
2. Ensure site design compliance with the Installation Development Plan (IDP) and its component plans and Installation Facilities Standards (IFS).
3. Promote integrated design with on-site solutions such as engineered small-scale hydrologic controls versus base-wide infrastructure; consider open space, natural features, bioswales, building roofs, streets, and paved surfaces.
4. Limit the impact of development on land and water resources. All site elements and infrastructure will reinforce an image of sustainability, with reduced energy demand, renewable-energy usage, and water conservation.
5. Consider energy conservation during site design for the following categories: building and site lighting, auxiliary systems and equipment (refrigerators, elevators, etc.), building envelope, electric power and distribution, HVAC systems and equipment, service hot water, energy management (metering, EMCS).
6. Coordinate on-site renewable-energy systems and components to minimize area requirements and maximize efficiencies. Appropriately buffer and screen these and other mechanical systems and equipment.
7. System maintainability is a critical aspect of a facility. Provide adequate clearances around all pieces of equipment for periodic maintenance, inspection and cleaning. Provide the manufacturer's recommended minimum clearances or code required clearances, whichever is more stringent. System maintainability will be coordinated between all systems. Service of one piece of equipment will not require disturbance of adjacent equipment (for example do not block access to lights with piping or conduit).
8. Routine maintenance (filters, lights, lubrication, inspection, etc.) requires the most frequent and easiest access. Where maintenance access requires the use of portable ladders they will be no more than 10' maximum. Provide adequate space to use them properly. Access requirements over 10' require ship ladders, stairs, platforms, catwalks, etc. unless approved otherwise by Dover AFB.
9. Component Replacement (coils, fans, motors, etc.) requires less frequent access. However since this normally has the greatest impact on the facility user this work must be done quickly and efficiently. Provide all items necessary to perform these tasks (work platforms, equipment access hatches/panels, hoists, cranes, freight elevators, ladders, stairs, etc.).
10. Equipment Replacement (air handling unit, switchgear, boilers, heat pumps, etc.) requires the least access. Since this occurs very seldom the need for permanent equipment to support these tasks is not required. However, equipment replacement must be accommodated and the facility will include items such as removable wall sections, access routes, etc. to allow replacement with the least amount of collateral damage. New building projects should preserve open space and protect natural habitat.
11. Conform to existing topography to the greatest extent possible and use slopes to increase site and building efficiencies. Design sites to minimize irrigation and impacts to stormwater runoff.
12. Carefully study new project sites to identify the character of adjacent buildings, streets, landscaping, and site design elements. Reinforce the existing character in new site design.

13. Consider relationships to adjacent facilities and district / centralized heating and cooling infrastructure and cost effectively connect building systems to harvest heat, grey water or other beneficial byproducts.

14. Minimize existing and planned obstructions from landscaping, structures, topography, and adjacent developments to preserve solar access and natural ventilation.

15. Purposefully integrate service access, receiving and storage areas to eliminate the need for visual screening.

16. Appropriately connect to the base network of streets, sidewalks and trails using drive aisles, parking areas, walkways, paths, and bicycle routes addressing both vehicles and pedestrians.

17. Applicably coordinate heat island mitigation in paving and roof designs when implementing an integrated approach to stormwater management.

18. Consider the location of "Designated Tobacco Areas."

C01.2. Building Orientation

Applicable N/A Select number of graphics / images (large: 800 px x 440 px) to insert 1

Image Tool 800 x 440

Applicable N/A Select number of graphics / images (small: 250 px x 188 px) to insert 6

Image Tool 250 x 188

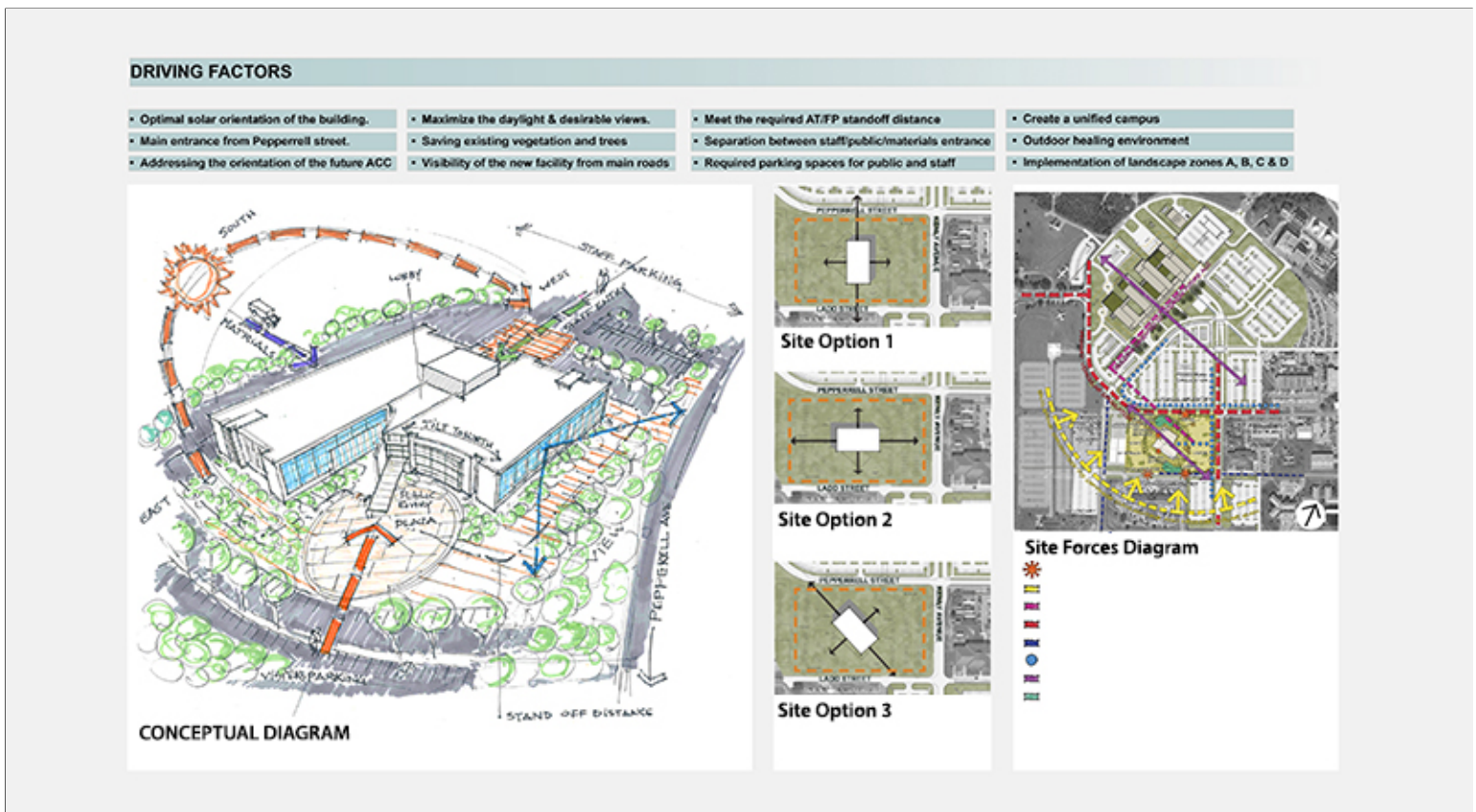

Conceptual Site Analysis and Site Design Diagram

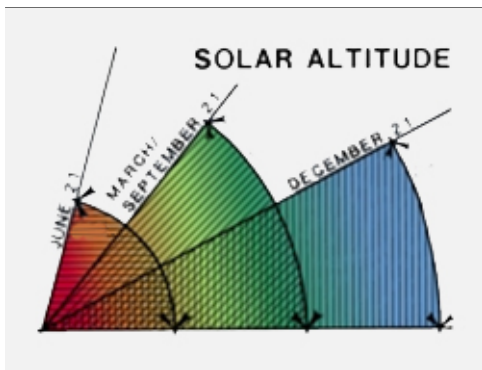

Local Solar Data

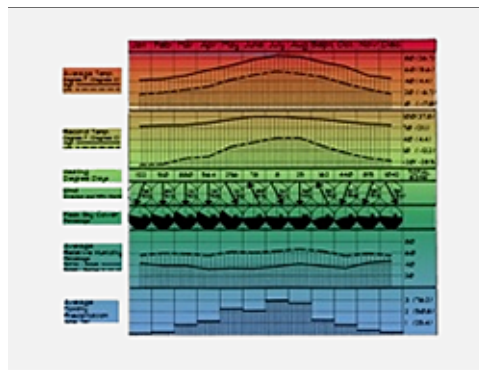

Local Climate Data

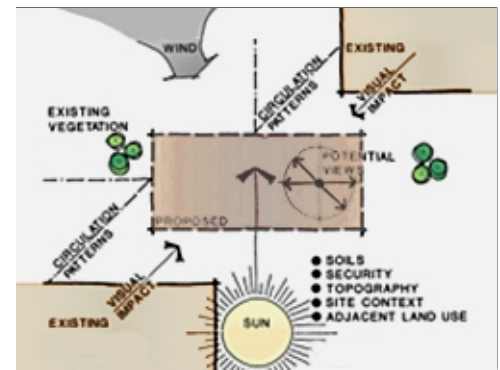

Site Data

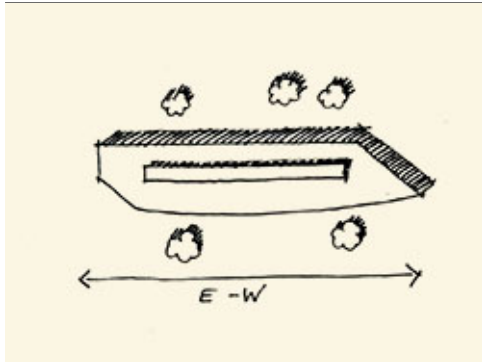

East-West Axis

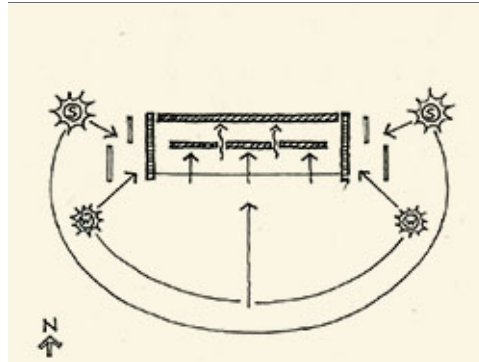

Optimum Solar Control

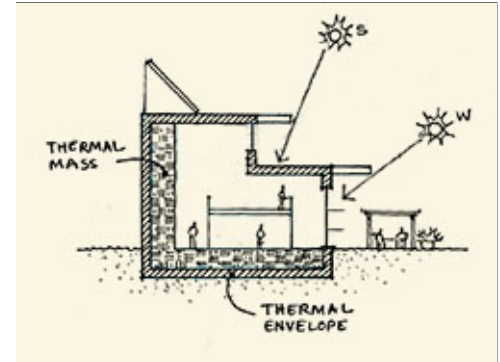

Maximized Shading

1. Ensure the site will accommodate optimum requirements for building orientation, which is with the long axis parallel to the east/west direction for rectilinear CONUS buildings.
2. Meet Installation Facilities Standards (IFS) requirements for the locations of the building's passive and renewable-energy systems—including geothermal and solar systems—and exterior shading systems.
3. Locate the building(s) and permitted ancillary structures to promote solar gain, solar shading, natural ventilation, rainwater harvesting, wind buffering and other beneficial passive systems. Consider natural ventilation during the design of HVAC systems.
4. Consider relationships to adjacent sites and their facilities and infrastructure, and cost effectively integrate building systems to harvest heat, grey water or other beneficial byproducts.
5. Consider the "public side" of the building, its views and the location of the main entrance.

C02. UTILITIES

Comply with AF Corporate Standards for Site Development:
<http://afcs.wbdg.org/site-development/index.html>

Comply with AF Corporate Standards for Utilities:
<http://afcs.wbdg.org/site-development/utilities/index.html>

C02.1. Utility Components

Applicable N/A Large graphics do not apply

Applicable N/A Select number of graphics / images (small: 250 px x 188 px) to insert 5

Image Tool 250 x 188



Screen Wall



Landscape Screening



Piping Painted to Match Wall



Screen Utility Elements



Wall and Landscape Screen

1. Provide all on-site utility service lines below grade for Facility Group 1; when mounting elements (such as utility cabinets, communications equipment and water valves) above grade is unavoidable, paint these consistently and provide visual screening following Installation Facilities Standards (IFS).
2. Above grade utility features (fire hydrants, PIVs, FDCs, electrical transformers and switchgear, gas meters, etc.), which are located in or within 10 feet of adjacent vehicular traffic areas (without concrete roadway curb), will be protected by concrete filled Schedule 40 steel pipe bollards. Placement of bollards must not obstruct operational or maintenance access to the protected feature. Place concrete pavement within and including the area of bollards. Electrical transformers and switchgear will be provided with a minimum of 10 feet clearance on door sides of the equipment.
3. Refer to Section C07.1. for specific requirements for bollards.
4. Provide square or circular reinforced concrete collars around all cleanouts, valve boxes, monitoring wells or similar features located within turfing areas (collars not required within paved areas). Size of the collar will be 8 inches outside of the cleanout or valve box.
5. Provide installation of utility infrastructure to support near term and future electric vehicle charging stations.
6. Define all service entry points into the building and route distribution below grade into an interior space within the facility; exposed conduits, cables and wires on exterior walls are not permitted for Facility Group 1.
7. Include consideration of appropriate placement of meters in support of Automated Revenue Management Services (ARMS).

8. Permanent metering must be provided for electric, natural gas, and water utilities at every Dover AFB facility so that utility consumption for each facility can be monitored and tracked over time. Metering of fire water service is not required. Whenever possible electric meters will be located inside the electrical room, otherwise they will be located in the mechanical room. Water meters will be located inside the mechanical room. Gas meters will be located on the building exterior at the gas service entrance at the rear of the building. Electric, natural gas, and water meters will be remote readable.

9. Heating, Ventilating, and Air Conditioning Systems requires that building electricity, water, and natural gas be included in the HVAC Direct Digital Controls minimum points list. These points must be visible to the Dover Air Force Base's Energy Management and Control System (EMCS). All utility metering devices must be connected to the Base's EMCS.

10. Limit exterior mechanical distribution systems such as exterior steam, chilled water, and hot water distribution to Group 3 facilities; when required for Group 1 and 2 facilities integrate with the architecture and provide visual screens following IFS.

11. Direct roof drainage to underground collection when feasible or provide splash blocks / paved channels to intercept roof drainage at grade.

C03. PARKING AREAS

Comply with AF Corporate Standards for Site Development:

<http://afcs.wbdg.org/site-development/index.html>

Comply with AF Corporate Standards for Parking Areas:

<http://afcs.wbdg.org/site-development/parking-areas/index.html>

C03.1. Configurations and Design

Applicable N/A Large graphics do not apply

Applicable N/A Select number of graphics / images (small: 250 px x 188 px) to insert 5

Image Tool 250 x 188

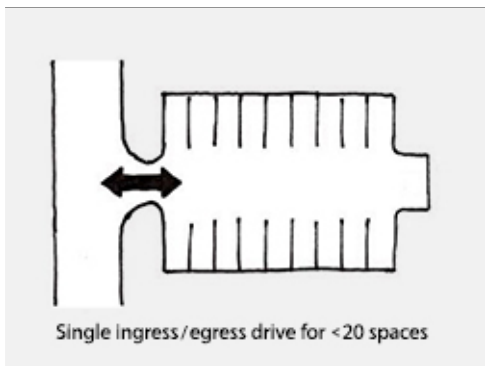

Small Lot Configuration

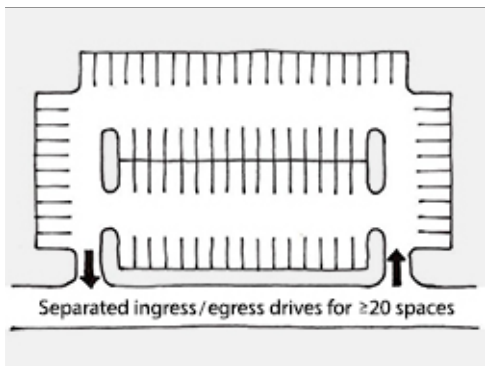

Large Lot Configuration

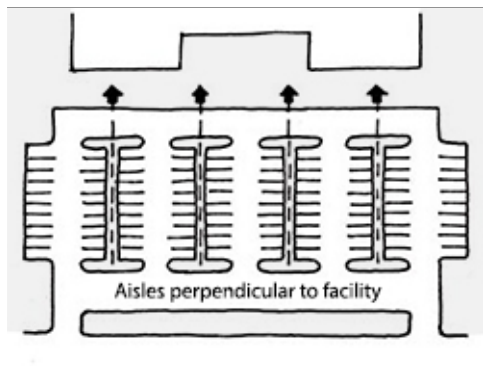

Facility Group 1 Configuration



Connected Parking Lot



Adjacent Parking Lot

1. Standard parking lot configuration will be perpendicular with two way circulation, with standard vehicle stall dimensions of 10' width and 18' depth, and minimum 26' traffic aisle width. Stall widths of 9.5' and/or diagonal parking configurations (60 degree) will only be considered in unusually constrained site plans with approval of the Dover AFB. Parking lot designs will include a reasonable number of motorcycle parking stalls (approximately 5%) with a standard stall width of 5', placed on concrete pavement and reasonably near the main facility entrance.

2. The use of parking bumpers or wheel stops at vehicle parking areas is not permitted.

C03.1.1. Paving and Striping

Applicable N/A Large graphics do not apply

Applicable N/A Small graphics do not apply

Facility Group 1 paving materials will be as follows.

Primary: Asphaltic concrete

Secondary: Concrete

Accent: Permeable pavers

Facility Group 3 paving materials will be as follows.

Primary: Concrete where operationally required

Secondary: Asphaltic Concrete

Accent: N/A

Facility Group 2 paving materials will be as follows.

Primary: Asphaltic Concrete

Secondary: N/A

Accent: N/A

Facility Group 4 paving materials will be as follows.

Primary: Asphaltic Concrete

Secondary: N/A

Accent: N/A

1. The use of State of Delaware Department of Transportation (DelDOT) materials and mix designs for graded aggregate base, intermediate and wearing surface courses of hot-mix hot-laid asphalt concrete may be permitted if they comply with the respective UFGS criteria.

C03.1.2. Curbing

Applicable N/A Large graphics do not apply

Applicable N/A Select number of graphics / images (small: 250 px x 188 px) to insert 3

Image Tool 250 x 188

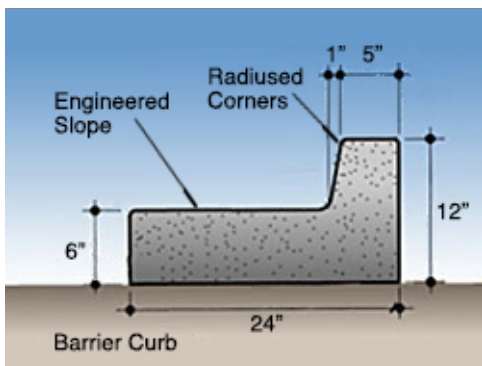

"Barrier" Curb

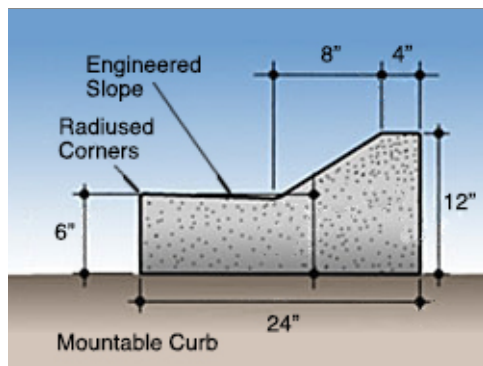

"Mountable" Curb

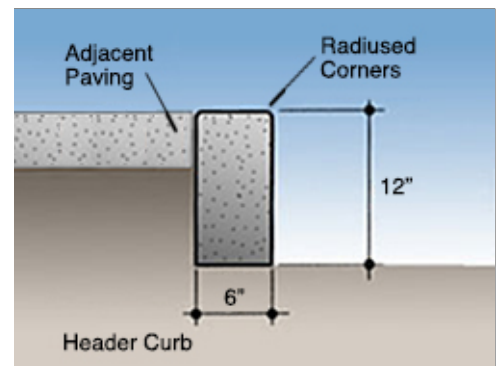

Header Curb

Facility Group 1 curbing / edging materials will be as follows.

Primary: Concrete

Secondary: N/A

Accent: N/A

Facility Group 2 curbing / edging materials will be as follows.

Primary: Concrete

Secondary: N/A

Accent: N/A

Facility Group 3 curbing / edging materials will be as follows.

Primary: Concrete

Secondary: N/A

Accent: N/A

Facility Group 4 curbing / edging materials will be as follows.

Primary: Concrete

Secondary: N/A

Accent: N/A

1. All roadway and parking lot curb will be integral curb and gutter and will have a cross section profile as shown for DeIDOT Type 3 Integral Curb and Gutter. Upon approval by Dover AFB, exceptions may be permitted in situations where small portions of existing curb are replaced and must match existing. Provide a reverse slope gutter pan to permit drainage in situations where there is little or no available longitudinal slope along the gutter line.

2. In general all streets and parking lots will be provided with integral curb and gutter. Upon approval by Dover AFB, exceptions may be permitted for perimeter control, service and access roadways or similar pavement areas.

3. Where the use of integral curb and gutter is not possible, specify concrete filled pipe bollards.

4. Curbs will be constructed on graded crushed aggregate in a minimum thickness matching adjacent roadway construction. Sidewalks will be a minimum of 4 inches thick concrete and be provided with welded wire fabric reinforcement constructed on a minimum of 4 inches of graded crushed aggregate or structural fill. Sidewalks which cross vehicle entrances will be a minimum of 6 inches thick concrete and provided with welded wire fabric reinforcement constructed on a minimum of 6 inches of graded crushed aggregate or structural fill or greater if required based on vehicle loads.

C03.1.3. Internal Islands and Medians

Applicable N/A Large graphics do not apply

Applicable N/A Select number of graphics / images (small: 250 px x 188 px) to insert 2

Image Tool 250 x 188



Parking Lot Landscaped Island



Parking Lot Island with Xeric Plantings

1. All new parking lots in Groups 1 and 2 will be constructed of asphaltic concrete paving.

2. Porous paving may be considered on a case-by-case basis.

3. Cost-effectively provide light-colored concrete to reduce heat island effect; otherwise install asphaltic concrete paving. Dirt, gravel, and grass lots are not allowed.

4. Use consistent striping, angles and stall sizes in all parking areas.

5. All parking will be marked with white stripes of paint or applied vinyl coatings. Red or yellow markings will only be used for safety purposes and must be kept to a minimum. All lines will be four inches (4") wide.

C03.2. Parking Structures

Applicable N/A Large graphics do not apply

Applicable N/A Small graphics do not apply

1. Parking structures are encouraged in land-constrained locations when economically feasible.

2. Consider near term and future electric vehicle charging stations and renewable energy generation development during the analysis and design.

3. Consider opportunities for integrating parking structures into multi-use developments with pedestrian-oriented uses located on the ground floor and parking on upper levels; ensure AT guidelines are fully addressed.

4. Structures may be constructed below grade with roofs serving as vegetated areas or plazas.

C03.3. Connectivity

Applicable N/A Large graphics do not apply

Applicable N/A Small graphics do not apply

1. Refer to the Installation Development Plan (IDP) for locations of transit stops and pedestrian and cycling networks; provide appropriately sized sidewalks and bike paths to connect facilities and users to these networks.

2. Provide amenities such as rain and shade shelters, trees, and benches to encourage and facilitate use of public transportation.

3. Evaluate the IDP for the current and planned network of roads and optimally develop vehicular access to and from the site.

C04. STORMWATER MANAGEMENT

Comply with AF Corporate Standards for Site Development:

<http://afcs.wbdg.org/site-development/index.html>

Comply with AF Corporate Standards for Stormwater Management:

<http://afcs.wbdg.org/site-development/stormwater-management/index.html>

C04.1. Stormwater Requirements

Applicable N/A Large graphics do not apply

Applicable N/A Select number of graphics / images (small: 250 px x 188 px) to insert 3

Image Tool 250 x 188



Stormwater Element



Drainage Swale



Stormwater Discharge to Swale

1. Design all stormwater systems including retention ponds, detention areas, channels, etc. as on-site amenities that are consistent with natural systems and drainage patterns, that help sustain the base landscape with beneficial functionality and that provide aesthetic appeal; coordinate with the base Stormwater Management Plan.
2. Incorporate bioswales into the design of all roadway, parking and facility roof systems to enhance water quality and support the overall stormwater system.
3. Permeable paving may be used in areas that are not subjected to severe freeze-thaw cycles.
4. Provide rainwater harvesting and storage that is attached to the building's roof drain systems to support grey water irrigation; consider winter temperatures in the design.
5. When underground drainage systems are required establish a maintenance program to include removal of sediments and debris; inspect joints seasonally for alignment to prevent leakage and the development of voids and surface failures.
6. Cost-effectively integrate stormwater systems with AT measures.
7. Structures. Manholes and drainage inlets will be precast concrete and will be used at all changes in horizontal or vertical alignment. Inaccessible junction boxes (i.e., without manhole lids) must not be used. Maximum spacing of manholes or drainage inlet structures will be 300 feet. Cast-in-place steps will be used in all drainage structures with a depth greater than 4-feet. Manholes and drainage inlets will have cast-in-place concrete flow channels.
8. Pipe. Minimum pipe size will be 15 inch unless approved otherwise by Dover AFB. Allowable pipe types are 1) reinforced concrete pipe (RCP) Type III, IV, or V as appropriate for the depth of cover and type of loading, and 2) high density polyethylene (HDPE). Non-allowed pipe types are ductile iron, corrugated steel, and corrugated aluminum.
9. Building downspouts will discharge directly to an underground storm water collection system. Building downspout collection piping will be PVC SDR 35 or HDPE and a minimum of 6 inch diameter. Transitions will be through painted cast-iron boots at grade.
10. The preferred material is Polyvinyl Chloride (PVC) pipe and fittings for new sanitary sewer gravity mains and laterals.

C05. SIDEWALKS, BIKEWAYS AND TRAILS

Comply with AF Corporate Standards for Site Development:

<http://afcfs.wbdg.org/site-development/index.html>

C05.1. Circulation and Paving

Applicable N/A Large graphics do not apply

Applicable N/A Select number of graphics / images (small: 250 px x 188 px) to insert 3

Image Tool 250 x 188



Sidewalk Connecting Facilities



Detached Sidewalk



Trail

Facility Group 1 sidewalks, plazas, and courtyards paving materials will be as follows.

Primary: Permeable Pavers

Secondary: Concrete Edging

Accent: N/A

Facility Group 2 sidewalks, plazas, and courtyards paving materials will be as follows.

Primary: Permeable Pavers

Secondary: Concrete Edging

Accent: N/A

Facility Group 3 sidewalks, plazas, and courtyards paving materials will be as follows.

Primary: Pervious Concrete

Secondary: N/A

Accent: N/A

Facility Group 4 sidewalks, plazas, and courtyards paving materials will be as follows.

Primary: Pervious Concrete

Secondary: N/A

Accent: N/A

1. Maintain efficient geometry and accessibility to connect building entrances to adjacent parking areas and activity areas and to the base transportation system following AT. Efficiently use materials to optimize life-cycle costs and to minimize maintenance.

2. Generally conform horizontal layouts of sidewalks to the geometric configuration of adjacent buildings, streets, parking lots, and other adjacent related site amenities. Occasional meanders and/or jogs may be included to capture views, to coordinate with landscaping or accommodate site constraints.

3. Walks in parking areas will provide a direct path using "safe islands" and "peninsulas" to encourage safety. Walks parallel to streets will follow streetscape guidelines. Clearly mark pedestrian crossings at vehicular routes.

4. Mitigate heat island by providing high-albedo, shaded sidewalks. Permeable pavers will be used on all sidewalks, plazas and courtyards in Facility Groups 1 and 2; use pervious concrete in Groups 3 and 4. The designer will incorporate appropriate expansion and construction joints.

5. Only experienced contractors will install pervious pavements.
6. Consider an integrated approach that could include stormwater management (permeable surfaces) and complement the design of the storm drainage system when appropriate.
7. Pedestrian paths should be at least 5' in width to allow for comfortable side-by-side walking.
8. Sidewalks leading to a building main entrance and at the interior of parking lots will be a minimum width of 6'. Walks greater than 10' wide may be used at high-density pedestrian areas where volumes of traffic justify added material.
9. Where cars park adjacent and head-in to the sidewalk and wheel stops are not used, such perimeter walks will be increased to a minimum width of 8' to accommodate overhangs of the parked vehicles.
10. All sidewalks must have positive drainage to prevent ponding of water with slopes ranging from 2.1% to 4.2%. Walks with a slope greater than 4.2% will be designed as ramps following accessibility guidelines. All walks will have a minimum cross slope of 2.1%.
11. Pavers will conform to the following range of color: Earth tones. Pavers used on walks will typically be 4"x8" nominal in size.
12. Connect to the bicycle circulation system and provide bicycle parking with a suitable means for securing bicycles following IFS. Consider changing/shower facilities for use by cyclists.
13. Refer to the Installation Development Plan for future trails, bicycle paths, and sidewalks.
14. Utilize DelDOT standard drawings for curb ramps. Although not required by the Architectural Barriers Act (ABA), all curb ramps on Dover AFB will include truncated dome detectable warnings consisting of 2' x 2' (nominal) precast concrete pavers, as manufactured by Hanover Architectural Products, in "Red 15" color for concrete sidewalk locations, or approved equal by Dover AFB. The precast detectable warnings pavers will be installed in a mortar bed or monolithically cast within the concrete sidewalk pavement with a minimum 4 inch thick concrete base, with paver joints of suitable width to accept either an appropriate grout or sealant.
15. Provide connecting sidewalks from all building entrance/exits. Mechanical, electrical, and communications room entrances will be accessible via sidewalks or pavements.

C05.1.1. Ramps and Stairs

Applicable N/A Large graphics do not apply

Applicable N/A Small graphics do not apply

1. Use ramps instead of stairs for sidewalks, bikeways and trails and at all buildings where possible. Where steps are unavoidable, follow UFC 1-200-01 and its references to the International Building Code.

C05.1.2. Lighting

Applicable N/A Large graphics do not apply

Applicable N/A Select number of graphics / images (small: 250 px x 188 px) to insert 1

Image Tool 250 x 188



Lighted Bollards

1. Provide lighting for all stairs and landings where traffic warrants.
2. Refer to the Lighting section for path lighting along sidewalks, bikeways and trails.

C06. LANDSCAPE

Comply with AF Corporate Standards for Site Development:

<http://afcs.wbdg.org/site-development/index.html>

Comply with AF Corporate Standards for Landscape:

<http://afcs.wbdg.org/site-development/landscape/index.html>

C06.1. Climate-based Materials

Applicable N/A Large graphics do not apply

Applicable N/A Select number of graphics / images (small: 250 px x 188 px) to insert 2

Image Tool 250 x 188



Indigenous Species



Drought Tolerant Species

1. Projects will typically not include landscaping unless specifically required by the project scope and included within the project Statement of Work, Request for Proposal, or approved by Dover AFB. When landscaping is required, the project will include a landscaping plan and supporting details in accordance with the requirements of UFC 3-201-02 "Landscape Architecture". When included in the project, landscape designs and plantings will be appropriate to the natural environment and consistent with the

installation's integrated natural resources management plan. Designs will utilize xeriscaping to the maximum extent possible, using low- to no-maintenance plants, vegetation, and ground cover.

C06.1.1. Landscape Design Concept

Applicable N/A Large graphics do not apply

Applicable N/A Select number of graphics / images (small: 250 px x 188 px) to insert 3

Image Tool 250 x 188



Trees Defining Space



Accent Landscaping



Seasonal Color

1. Develop, maintain and implement a climate-based plant list with landscape features using a regionally appropriate palette of materials to promote energy efficiency, preserve drainage patterns, inhibit erosion, improve air quality, lower maintenance and add beauty. Follow UFC 3-201-02 Landscape Architecture.
2. Landscaping is required for all newly developed sites and facilities; preserve existing native landscape where possible and avoid overplanting.
3. Concentrate landscaping in Facility Group 1 and along major thoroughfares and integrate these landscaped areas into the base's stormwater management plan. Refer to the Streetscape Envelope Standards in this IFS.
4. All Facility Group 1 and 4 sites will be landscaped at their entire perimeter; limit formal planting arrangements to formal spaces typically associated with Group 1. Landscape public spaces near the main entrances of Group 1 facilities.
5. Facility Group 2 and 3 sites may have a native undisturbed landscape except at the main entrances of Group 2, which should be newly landscaped.
6. Facility plantings will follow the Installation Facilities Standards (IFS) plant list, which is based on the specific microclimates created by the adjacent building: shadow areas, protected areas, zones adjacent to thermal mass, and availability of rainwater and/or grey water.
7. Provide open spaces as transitions between developed and native areas that promote quality of life and provide visual relief and allow walkable connections to the transportation system.
8. Return suitable areas to a natural state to minimize and, whenever possible, eliminate ground maintenance requirements; expand prairie areas where appropriate with native plants to eliminate mowing and maintenance requirements.
9. In tree clusters replace grass with naturalized shrub beds and leaf litter mulch to eliminate mowing requirements.
10. Use plantings in open spaces to reinforce the space as a visual asset.
11. Consider landscape windbreaks when suitable for the local climate.
12. Integrate security requirements into the landscape design. Coordinate the heights of trees and shrubs and note restrictions for plantings following UFC 4-010-01.
13. Berms may be used as an integral part of the overall landscape strategy for screening, security and/or visual interest.

14. Provide a 2 feet wide lawn maintenance strip consisting of welded wire fabric reinforced 4 inch thick Portland cement concrete pavement adjacent to buildings where EIFS exterior wall systems extend to grade to protect against errant lawn mowing equipment.

15. Maximum slope of turfed areas will be 4H:1V to facilitate mowing operations.

C06.1.2. Xeriscape Design Principles

Applicable N/A Large graphics do not apply

Applicable N/A Select number of graphics / images (small: 250 px x 188 px) to insert 1

Image Tool 250 x 188



Mulched Planting Bed

1. Apply xeriscape principles following UFC 3-201-02, Appendix B, and Air Force Corporate Facilities Standards.

2. Facility plantings are encouraged to use native plant species and to consider specific microclimates created by the adjacent building: shadow areas, protected areas, zones adjacent to thermal mass, and availability of rainwater and/or grey water.

C06.1.3. Minimizing Water Requirements

Applicable N/A Large graphics do not apply

Applicable N/A Select number of graphics / images (small: 250 px x 188 px) to insert 1

Image Tool 250 x 188



Xeric Plant Materials

1. Reasonably reduce demand on potable water while seeking opportunities to increase alternative water sources for irrigation. Reduce or eliminate the use of potable/domestic water for purposes of landscape architecture maintenance, consistent with existing legal or contractual obligations, and prohibit potable-water irrigation in new construction beyond establishment following current DoD and Air Force policy.

C06.1.4. Plant Material Selection

Applicable N/A Large graphics do not apply

Applicable N/A Small graphics do not apply

1. Use only native, naturally occurring plant materials including grasses or turf suited for the local climatic conditions in the landscape design; potable-water irrigation systems are discouraged beyond the establishment period.
2. New facilities are encouraged to use native plant species as indicated on the plant lists available from the BCE.
3. Trees should be the focus of landscape plantings and, where possible, should be a mix of deciduous and evergreen species for variety; provide tree grates when appropriate and use tree guards on smaller trees.
4. Ground covers are only recommended when minimal maintenance is required.
5. Turf areas should be limited to those that can be sustained by natural rainfall or grey water (non-potable) irrigation systems; turf may be defined by at-grade concrete mow strips to lessen maintenance.
6. Analyze soils and provide organic amendments as needed to improve plant growth and conserve water.
7. All plant material will have one-year warranty and is subject to approval by the Base Landscape Architect.
8. Do not utilize the following landscaping material from Appendix A3 of the Dover AFB Architectural Compatibility Plan:
 - a. Shrubs- *Berberis thunbergii*, *Euonymus alata compacta*, *Spiraea japonica* "Anthony Waterer", *Spiraea japonica* "Little Princess", *Viburnum plicatum* var. *tomentosum*, Dwarf *Spiraea* (Little Princess), and Double File *Viburnum*.
 - b. Groundcovers and Vines- *Hedra helix* "Baltica", *Vinca minor* Periwinkle, and Hardy English Ivy.
9. Seed. Specify seed mixture as required by the Delaware Department of Transportation Standard Specification Section 908 "Table A. Permanent Grass Seeding - Dry Ground".
10. Tree Replacement. Any existing trees necessarily removed by design or damaged as a result of construction activities will be replaced in kind unless approved otherwise by Dover AFB. Existing trees which are too mature to be replaced in kind will be replaced with a number and caliper of trees of equal value. The minimum caliper size is 2-inch. For example, an existing 12-inch caliper tree can be replaced with six 2-inch caliper trees of similar species or species of equal value.

C06.1.5. Water Budgeting (Hydrozones)

Applicable N/A Large graphics do not apply

Applicable N/A Small graphics do not apply

1. Comply with DoD and Air Force policy on potable-water irrigation systems.
2. Provide irrigation systems in new construction to establish plant materials following "Water for Landscaping" in UFC 1-200-02. Note the climate zone and annual rainfall for the locale.
3. New buildings will cost-effectively integrate a grey-water reclamation system following UFC 1-200-02, which provides source water for an automatic drip irrigation system; connect adaptive plantings adjacent to facilities to a grey-water irrigation system when available and discontinue the use of potable water for irrigation after the establishment period.
4. Provide irrigation design following UFC 3-201-02. Install drip irrigation products and components following UFGS Section 32 84 24 Irrigation Sprinkler Systems. Match the color of valve box lids to the adjacent ground treatment (i.e. green at turf & native seed areas, brown at wood mulch & rock areas).

5. Life cycle cost-effectively equip irrigation systems to sense soil moisture, rainfall and wind to minimize unnecessary watering; incorporate drip irrigation systems as the primary source.

C06.1.6. Base Entrance Landscaping

Applicable N/A Large graphics do not apply

Applicable N/A Select number of graphics / images (small: 250 px x 188 px) to insert 1

Image Tool 250 x 188



Trees Outside Sight Lines

1. At the main gate, reinforce a sense of arrival through a well-designed concentration of landscape elements consistent in visual quality with Facility Group 1.

2. Ensure landscaping has seasonal features with spring and fall color and a combination of evergreen and deciduous trees and shrubs for winter interest.

3. Integrate base signs and street and pedestrian lighting whenever feasible.

C06.1.7. Streetscape Landscaping

Applicable N/A Large graphics do not apply

Applicable N/A Select number of graphics / images (small: 250 px x 188 px) to insert 1

Image Tool 250 x 188



Trees as a Focal Point

1. Provide landscape designs with plant materials appropriately representing the level of quality of the adjacent Facility Group number. Refer to the Installation Elements section.

2. Select a variety of regionally appropriate streetscape plantings and grading to create a visual interest.

C06.1.8. Pedestrian Circulation Landscaping

Applicable N/A Large graphics do not apply

Applicable N/A Small graphics do not apply

1. Define walkways with landscaping where appropriate.
2. Provide rest areas along the pedestrian circulation network with human-scaled deciduous shade trees. Supplement tree plantings with finely textured shrubs when appropriate for the climate.
3. Provide wind breaks where required.

C06.1.9. Parking Lot Landscaping

Applicable N/A Large graphics do not apply

Applicable N/A Select number of graphics / images (small: 250 px x 188 px) to insert 2

Image Tool 250 x 188



Perimeter and Internal Landscaping



Landscaped Island

1. Integrate appropriate landscaping elements into parking areas to visually soften the appearance at a minimum rate of 5 percent of the total area.
2. Avoid trees that drop sap, fruit, or seeds, and use long-lived species; keep trees trimmed, removing dead and dying trees or branches.
3. Provide planting in islands within parking lots for shade and appeal following IFS and the base stormwater management plan.
4. Rain garden islands will be landscaped to receive rainwater runoff from adjacent impervious parking areas to be absorbed into the ground/planting bed. Native plants and groundcovers are recommended within the rain garden areas, which can survive without supplemental irrigation once established.

C06.1.10. Screen/Accent Landscaping

Applicable N/A Large graphics do not apply

Applicable N/A Small graphics do not apply

1. Provide complimentary accent landscaping at monuments and static displays.
2. At Facility Group 1, provide landscaping adjacent to all freestanding signs without distracting from the written communication.
3. Provide landscape screening of utility elements adjacent to Facility Group 1.

4. Providing landscaping as visual screening is preferred to the construction of walls and fences; berming and mounding may supplement landscape screening.

C06.1.11. Other

Applicable N/A Large graphics do not apply

Applicable N/A Small graphics do not apply

1. Specify only 100% biodegradable erosion control materials for permanent applications. Erosion control mats, blankets, or similar items containing non-biodegradable material such as nylon or plastic can become a nuisance to mowing operations. Non-biodegradable erosion control materials may only be used as a temporary measure and must be entirely removed prior to construction completion.

C07. SITE FURNISHINGS

Comply with AF Corporate Standards for Site Development:

<http://afcs.wbdg.org/site-development/index.html>

Comply with AF Corporate Standards for Site Furnishings:

<http://afcs.wbdg.org/site-development/site-furnishings/index.html>

C07.1. Furnishings and Elements

Applicable N/A Large graphics do not apply

Applicable N/A Select number of graphics / images (small: 250 px x 188 px) to insert 3

Image Tool 250 x 188



Bike Rack



Visual Screen Wall



Custom Site Furnishing

1. Provide a coordinated consistent inventory of site furnishings to positively contribute to the visual environment, image, and identity of the base; ensure durability, low maintenance, reduced visual clutter, and compatibility with the adjacent architecture.

2. Remove poorly located or redundant litter / ash receptacles, newspaper and bicycle racks, telephone booths, vending machines, walls and fences to reduce visual clutter and to lessen the requirements for maintenance.

3. Group 1 and 2 site furnishings will be precast and powder coated metal. Group 3 and 4 site furnishings will be powder coated or vinyl coated metal. Generally match the site furniture of adjacent facilities and the facility district.

4. Install needed outdoor seating (benches and low walls) in public gathering spaces near main and secondary building entrances. Low walls will match facility architecture.

5. Benches in Groups 1, 2, 3, 4, and parks will be powder coated steel.

6. Integrate functional bicycle racks with the design of the building's main entrance grounds in Facility Groups 1 and 2 while meeting AT requirements.

7. Limit the use of bollards, but when necessary for force protection use precast concrete in Groups 1 and 2; steel bollards in Group 3; anodized aluminum bollards in Group 4 and parks and trails. Illuminated bollards may be used as approved on a case-by-case basis.
8. Bollards adjacent to facilities, which are required to protect equipment, will be painted Dover AFB "Eagle Feather Tan". Standalone bollards away from buildings will be painted Dover AFB "Bald Eagle Brown". A 6-inch wide band of white reflective tape will be affixed to all bollards in non-paved areas. An additional 6-inch wide band of red reflective tape above the white band will be affixed to bollards in paved areas.
9. Locate architecturally coordinated containers for recycling, litter, ash, vending, etc., to minimize visual clutter and not visible from the building's main entrance. Minimize the use of freestanding planters.
10. Generally limit picnic tables, barbeque grills and drinking fountains to lodging, dormitories, housing areas, parks and recreation areas following IFS.
11. Flagpoles using approved materials may be installed at locations designated by IFS, and in accordance with AFI 34-1201.
12. Refer to the Overview Section "Facility Hierarchy" topic of this AFCFS for guidelines regarding ancillary structures such as pavilions and shade shelters.
13. Bus shelters will be provided only where there is a documented need and when approved on a case-by-case basis. Generally emulate the designs of adjacent shelters using powder coated or anodized aluminum structures.
14. Monuments and static displays will be limited. New elements are generally discouraged unless these are fully vetted through the base's approval process and designed following IFS.
15. When visual screening is necessary, consider landscaping as the first option; screen walls are permitted in Groups 1, 2 and 3 constructed of CMU.
16. For fencing, apply the standards for "Products, Materials and Color" in the following section. Limit those with the highest visual quality to Facility Group 1 where there is sustained maintenance. Define all levels of security and visual quality.
17. Do not use chain-link fencing at Group 1, 2 or 4 facilities; Limit the use of barbed-wire outriggers on chain-link fencing at industrial sites, unless required for additional security or protection of assets.
18. Wood fencing may be used in Facility Group 4 and in recreation areas following IFS for material and finish when there is sustained periodic maintenance.
19. Provide trash dumpster enclosures for Group 1, 2 and 3 facilities with brick piers, CMU walls, and metal gates. All gates will be factory finished dark bronze.
20. Specify screen wall materials and finishes that do not require painting or maintenance beyond periodic cleaning.
21. In groups 1, 2, 3, and 4 and in parks, picnic tables and seating will be vinyl coated steel. Generally limit picnic tables, barbeque grills and drinking fountains to lodging, dormitories, housing areas, parks and recreation areas.
22. Limit the use of freestanding planters to areas with ongoing maintenance.
23. Provide kiosks only where there is a documented need for visual communication of posted messages. When used, match adjacent facilities in materials and detailing and consolidate kiosks with other site furnishings within 30 feet of major pedestrian paths. Limit kiosks to facility Groups 1 and 2 and parks.
24. Manufacturers listed below are only provided to establish a baseline of equivalency among all applicable manufacturers.

C07.2. Site Furnishings Products, Materials and Color

Note: Apply the below base-wide standards for Site Furnishings (products, materials and color). Then refer to the Appendix and apply any additional requirements specifically related to the Facility District in which the project is located.

C07.2.1. Barbeque Grills

Applicable N/A

Number of base standards 2

Image Tool 250 x 188



Type: **Charcoal**

Applies to: Group 1 Group 2 Group 3 Group 4 Other

Mfr: Most Dependable Fountains, Inc.

Color: Natural stainless steel

Finish: Mill

Model #: SS BBQ Grill

Other: Concrete foundation, coordinate with Base Architect

UFGS: N/A

Type: **Natural Gas**

Applies to: Group 1 Group 2 Group 3 Group 4 Other

Mfr: BBQ Coach

Color: Natural stainless steel

Finish: Mill

Model #: 32" 4-Burner

Other: Built-in Concrete or masonry, coordinate with Base Architect

UFGS: N/A



C07.2.2. Benches

Applicable N/A

Number of base standards 2

Image Tool 250 x 188



Type: **Metal Strap Bench**

Applies to: Group 1 Group 2 Group 3 Group 4 Other

Mfr: Landscape Forms

Color: Dark Bronze

Finish: Powder coat

Model #: 6' length

Other: N/A

UFGS: N/A

Type: **Metal Strep Bench**

Applies to: Group 1 Group 2 Group 3 Group 4 Other

Mfr: The Park Catalog

Color: Dark Bronze

Finish: Powder coat

Model #: 6' length

Other: N/A

UFGS: N/A



C07.2.3. Bike Racks

Applicable N/A

Number of base standards 1

Image Tool 250 x 188



Type: **Style 1**

Applies to: Group 1 Group 2 Group 3 Group 4 Other

Mfr: Brandir International Inc.

Color: Galvanized, or dark bronze

Finish: Factory

Model #: The Ribbon Bike Rack, RB-07

Other: N/A

UFGS: N/A

C07.2.4. Bike Lockers

Applicable N/A

C07.2.5. Bollards

Applicable N/A

Number of base standards 3

Image Tool 250 x 188



Type: **Lighted Round**

Applies to: Group 1 Group 2 Group 3 Group 4 Other

Mfr: Dura Art Stone

Color: Weatherstone Gray with Silver shield

Finish: Textured precast / anodized aluminum

Model #: Rock aggregate

Other: 3000K LED Lamp, 360° downlighting

UFGS: N/A



Type: **Lighted Round Dome Top**

Applies to: Group 1 Group 2 Group 3 Group 4 Other

Mfr: Lithonia Lighting Products

Color: Dark Bronze

Finish: Anodized aluminum or powder coat

Model #: KBA

Other: Flared cone, 3000K LED Lamp

UFGS: N/A

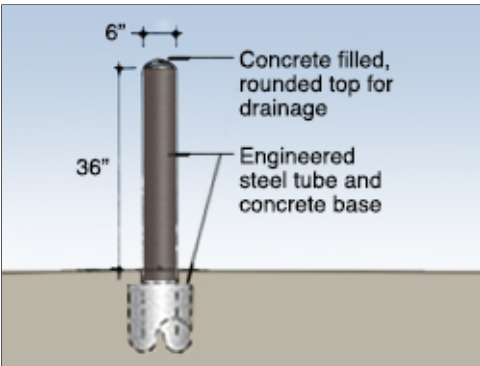

Type: **Building Protection, steel**

Applies to: Group 1 Group 2 Group 3 Group 4 Other

Mfr: (Bollard Cover) Reliance Foundry

Color: Brown cover may be field painted dark bronze

Finish: Factory

Model #: 6" Steel pipe, concrete filled, Cover: R-7173

Other: A 1" (25.4 mm) rigid conduit and box with shroud may be provided at top of bollard with a receiver/key switch application

UFGS: N/A

C07.2.6. Bus Shelters

Applicable N/A

Number of base standards 1

Image Tool 250 x 188

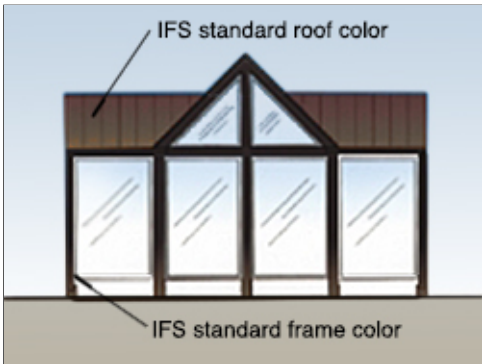

Type: **1**

Applies to: Group 1 Group 2 Group 3 Group 4 Other

Mfr: Custom

Color: Dark Bronze

Finish: Powder coated

Model #: Gabled roof

Other: Provide concrete slab and 2 pre-manufactured aluminum benches

UFGS: N/A

C07.2.7. Drinking Fountains

Applicable N/A

Number of base standards 1

Image Tool 250 x 188



Type: **Pedestal**

Applies to: Group 1 Group 2 Group 3 Group 4 Other

Mfr: Most Dependable Fountains, Inc.

Color: Natural

Finish: Stainless Steel

Model #: MDF 440 SMSS

Other: Accessible

UFGS: N/A

C07.2.8. Dumpster Enclosures / Gates

Applicable N/A

Number of base standards 1

Image Tool 250 x 188

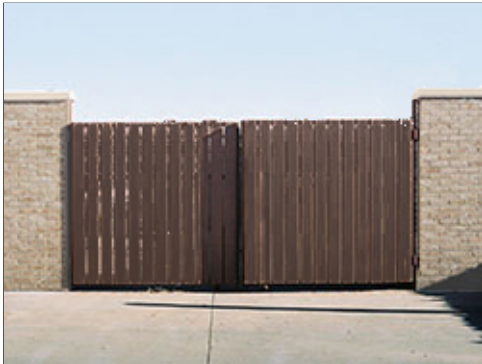

Type: **1: Brick and Steel**

Applies to: Group 1 Group 2 Group 3 Group 4 Other

Mfr: Custom

Color: Red brick blend, dark brown doors

Finish: Face brick, powder coated doors

Model #: Match adjacent building

Other: Steel gates and hardware, dark brown, dumpsters will be painted dark brown

UFGS: Section 04 20 00 Unit Masonry

C07.2.9. Fencing

Applicable N/A

Number of base standards 5

Image Tool 250 x 188

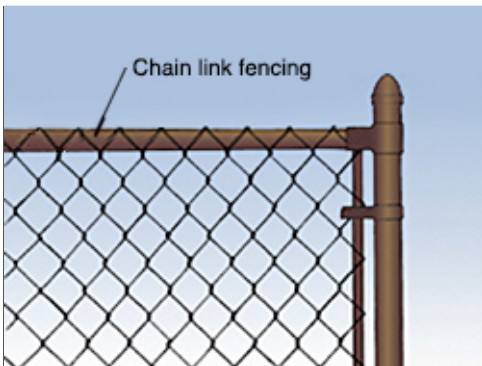

Type: **Style A Barrier: High security, low visibility**

Applies to: Group 1 Group 2 Group 3 Group 4 Other

Mfr: General Wire Co.

Color: Dark brown

Finish: PVC coating over galvanized steel

Model #: Chain link, steel posts and rails, gates and accessories

Other: Chain link fencing, for both perimeter and enclosure fencing, will be vinyl coated in the manufacturer's standard color of either black or dark brown (not green). If used, slat inserts must also be either black or dark

UFGS: Section 32 31 13 Chain Link Fences and Gates

Type: **Style B Barrier: High security, medium visibility**

Applies to: Group 1 Group 2 Group 3 Group 4 Other

Mfr: Custom

Color: Dark brown

Finish: Powder coat

Model #: Steel grid: flat bar stock verticals, round rod horizontals

Other: Steel posts, horizontal bars, braces, and accessories, in heights, lengths, and gauges as required; Close all ends of tubing

UFGS: Section 05 50 13 Miscellaneous Metal Fabrications

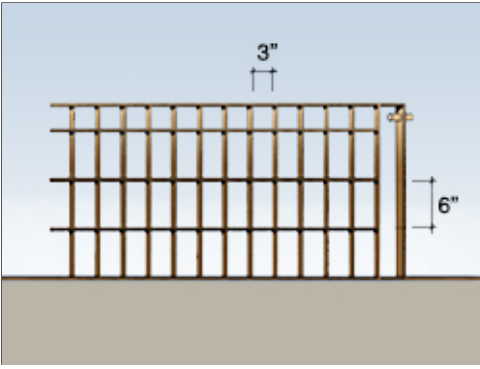

Type: **Style C Barrier: High security, high visibility**

Applies to: Group 1 Group 2 Group 3 Group 4 Other

Mfr: Custom

Color: Dark Brown

Finish: Powder coat

Model #: Steel posts, rails and pickets (vertical, bent outward at top)

Other: Posts, rails, and pickets in heights, lengths and gauges as required, (see Appendix for Facility Districts requirements)

UFGS: Section 05 50 13 Miscellaneous Metal Fabrications



Type: **Style D Barrier: Low security, High visibility**

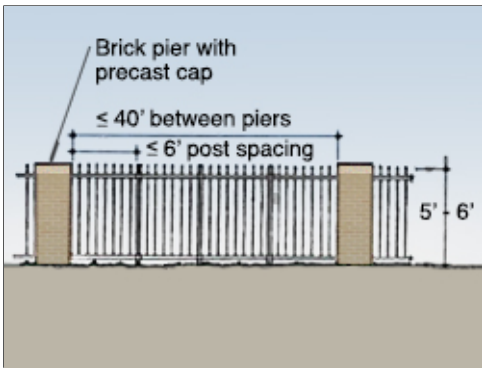

Applies to: Group 1 Group 2 Group 3 Group 4 Other

Mfr: Custom

Color: Red brick blend, dark brown fencing

Finish: Face brick, powder coated metal

Model #: Brick Piers with steel posts, rails and pickets

Other: Brick: 2'x2' (Height as required, equally spaced 12' to 40'), Steel posts: 4"x4" (equally spaced), Rails: 2"x2", Pickets: 1"x1" (6" o.c.); close all ends of tubing

UGFS: Section 04 20 00 Unit Masonry, Section 05 50 13 Misc. Metal

Type: **Style E Barrier: Low security, High visibility**

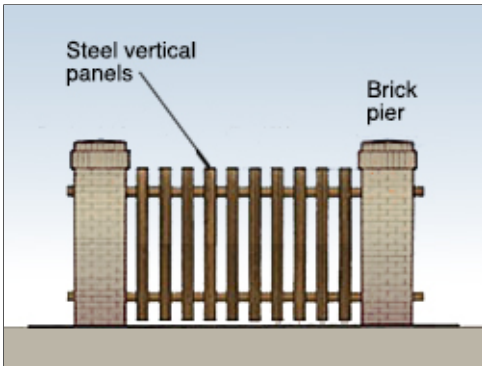

Applies to: Group 1 Group 2 Group 3 Group 4 Other

Mfr: Custom

Color: Red brick blend, dark brown fencing

Finish: Powder coated metal

Model #: Brick Piers with steel posts, rails and alternating panels

Other: Brick: 2'x2' (Height as required, equally spaced 8' to 40'), Steel posts: 4"x4" (equally spaced), Rails: 1-1/4"x1-1/2", vertical steel panels spaced alternately on each side of the rails; matching gates; close all ends

UGFS: Section 04 20 00 Unit Masonry, Section 05 50 13 Misc. Metal

C07.2.10. Flagpoles

Applicable N/A

Number of base standards 1

Image Tool 250 x 188



Type: **1**

Applies to: Group 1 Group 2 Group 3 Group 4 Other

Mfr: Eder Flag

Color: Natural aluminum

Finish: Satin Lustre

Model #: ECL30 IH, Internal Halyard

Other: 5" Butt Dia. 33' H (30' Exposed)

UFGS: N/A

C07.2.11. Lighting – Landscape / Accent

Please refer to the Lighting section.

C07.2.12. Litter and Ash Receptacles

Applicable N/A

Number of base standards 2

Image Tool 250 x 188



Type: **Style 1: Precast concrete**

Applies to: Group 1 Group 2 Group 3 Group 4 Other

Mfr: Materials, Inc.

Color: Weatherstone Gray

Finish: Smooth

Model #: TR-3225 Sante Fe (round or square)

Other: Rigid plastic internal liner,
http://materialsinc.com/wp-content/uploads/2014/10/TR-3225_SANTA_FE.pdf

UFGS: N/A

Type: **Style 2: Metal**



Applies to: Group 1 Group 2 Group 3 Group 4 Other

Mfr: Wabash Valley

Color: Black or as approved

Finish: Perforated Pattern

Model #: Urbanscape "E" with liner, 32 Gallon

Other: With dome top, without side door

UFGS: N/A

C07.2.13. Picnic Tables

Applicable N/A

Number of base standards 1

Image Tool 250 x 188



Type: **Metal, vinyl coated**

Applies to: Group 1 Group 2 Group 3 Group 4 Other

Mfr: Wabash Valley

Color: Brown or as approved

Finish: Factory vinyl coated

Model #: Signature Series, 46" Square Pedestal Tables with 4 Seats

Other: Perforated Pattern, In-ground mount

UFGS: N/A

C07.2.14. Planters

Applicable N/A

Number of base standards 1

Image Tool 250 x 188

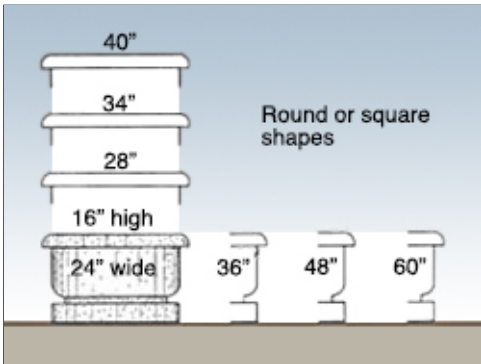

Type: **Precast concrete**

Applies to: Group 1 Group 2 Group 3 Group 4 Other

Mfr: Materials, Inc.

Color: Weatherstone Gray

Finish: Smooth

Model #: Santa Fe

Other: N/A

UFGS: N/A

C07.2.15. Play Equipment

Applicable N/A

Number of base standards 1

Image Tool 250 x 188



Type: **Steel**

Applies to: Group 1 Group 2 Group 3 Group 4 Other

Mfr: Little Tikes Commercial

Color: Varies

Finish: Powdercoated Steel

Model #: N-R-G Freestyle

Other: Coordinate with Base Architect

UFGS: N/A

C07.2.16. Screen Walls

Applicable N/A

Number of base standards 1

Image Tool 250 x 188



Type: **Brick / Concrete Masonry Unit (CMU)**

Applies to: Group 1 Group 2 Group 3 Group 4 Other

Mfr: Custom

Color: Tan brick, tan CMU

Finish: Powder coated metal

Model #: Brick Piers with steel posts, rails and alternating panels

Other: Brick: 2'x2' (Height as required, equally spaced 8' to 40'), CMU running bond walls, precast column caps and wall coping

UFGS: Section 04 20 00 Unit Masonry

C07.2.17. Tree Grates

Applicable N/A

Number of base standards 1

Image Tool 250 x 188



Type: **Cast Iron**

Applies to: Group 1 Group 2 Group 3 Group 4 Other

Mfr: Neenah Enterprises, Inc.

Color: Natural cast iron

Finish: Cast

Model #: 2-Piece, round or square

Other: N/A

UFGS: N/A

C07.2.18. Other

Applicable N/A

C08. EXTERIOR SIGNS

Comply with AF Corporate Standards for Site Development:

<http://afcs.wbdg.org/site-development/index.html>

Comply with AF Corporate Standards for Exterior Signs:

<http://afcs.wbdg.org/site-development/exterior-signs/index.html>

C08.1. Colors and Types

Applicable N/A Large graphics do not apply

Applicable N/A Select number of graphics / images (small: 250 px x 188 px) to insert 2

Image Tool 250 x 188



Freestanding Building Sign



Building Number Sign

1. Provide concise functional signs as a visually unifying element with consistent colors and types for all Installation and Gate Identification Signs; Building Identification Signs; Traffic Control Devices; Directional and Wayfinding Signs; and Informational and Motivational Signs.
2. Provide signs with the lowest overall life cycle costs considering initial cost, ongoing maintenance and lifespan while meeting quality standards. Follow IFS for specifications appropriate for the local climate to withstand weathering. Refer to Section C08.1.1 for colors of signs faces and sign posts.
3. Reduce the number of signs, reduce visual clutter and provide only essential signs required for identification, directions, instructions, and customer service following UFC 3-120-01. Remove non-conforming signs during renovation projects.
4. Use clear concise terms for content consistent with UFC 3-120-01.
5. Display of emblems on building exterior walls or other permanent structures is prohibited by UFC.
6. Raised "standout" letters and numbers may be used for Group 1 with approval on a case-by-case basis.
7. Group 2 and 3 facilities will have wall mounted facility signs with sizes and layouts following UFC 3-120-01. Signs are not permitted for Group 4 facilities.
8. Only one identification sign is permitted at each building entrance. Include a building address consistent with US Postal Service protocols following UFC 3-120-01.
9. Traffic Control Devices, which regulate vehicular traffic on the installation, must conform to the standards in the Manual of Uniform Traffic Control Devices (MUTCD) published by the Federal Highway Administration. Coordinate street signs with this IFS.
10. Provide Directional and Wayfinding Signs and address both pedestrian and vehicular traffic following UFC 3-120-01 for size, layout and content.

- 11. Reserved parking signs should be kept to a minimum. When approved, provide post-mounted sign faces in base standard materials and colors. Consider "bracketing" a designated area with a single sign at each end.
- 12. Parking lot identification signs may be used to identify areas or rows within large lots.
- 13. Follow the guidelines and requirements in ABAAS and the MUTCD for accessible parking signs.
- 14. Follow UFC 3-120-01 for Informational and Motivational Signs for size, layout and content.
- 15. Symbols or pictographs (graphic expressions of actual objects) may be used to indicate service, mandatory / prohibitory, sports, and recreation when rapid communication is necessary.
- 16. Force Protection signage may be applied to glass doors using white vinyl lettering.
- 17. Refer to UFC 3-120-01 for prohibited signs, which include those with animated, blinking, chasing, flashing, or moving effects.
- 18. Coordinate specific graphics requirements with Dover AFB project management.
- 19. Manufacturers listed below are only provided to establish a baseline of equivalency among all applicable manufacturers.

C08.1.1. Materials and Color Specifications

Applicable N/A Large graphics do not apply

Applicable N/A Small graphics do not apply

1. Acceptable sign vendor is Pioneer Supply (800-545-2233), 1710 N. Franklin St, Pittsburg, PA 15233. Pioneer Sign Kit catalog number "Series 3 K1260P, or approved equal by Dover AFB.

Materials and Color Specifications

Applicable N/A Number of base standards 3



Type: **Typical Sign Fce**

Applies to: Group 1 Group 2 Group 3 Group 4 Other

Mfr: Custom

Color: National Park Service brown with white lettering

Finish: Matte vinyl

Model #: Aluminum flat sheet

Other: Mount to square posts. Provide sizes following UFC.

UFGS: Section 05 50 13 Miscellaneous Metal Fabrications

Type: **Typical Sign Post**

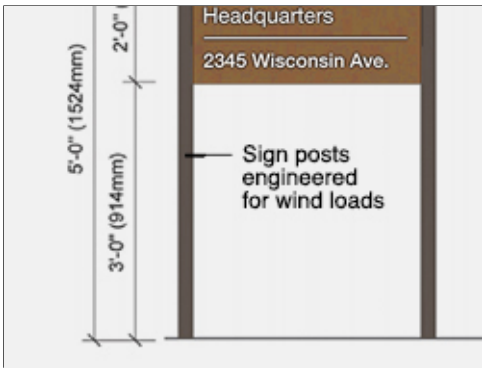

Applies to: Group 1 Group 2 Group 3 Group 4 Other

Mfr: Custom

Color: Dark bronze, powder coat finish

Finish: Matte

Model #: Extruded aluminum with capped top ends

Other: Square posts and squared ends. Provide engineered sizes.

UGFS: Section 05 50 13 Miscellaneous Metal Fabrications

Type: **Typical Sign Base**

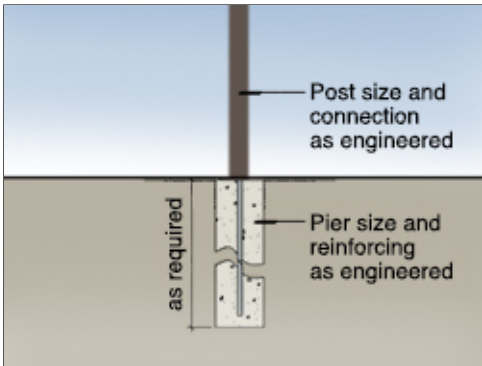

Applies to: Group 1 Group 2 Group 3 Group 4 Other

Mfr: Custom

Color: Natural Gray

Finish: Sonotube-formed

Model #: 24" height x 12" diameter, as engineered.

Other: At grade with 3/4" chamfer. Provide engineered sizes.

UGFS: UFGS 03 30 00 Cast-in-place Concrete

C08.1.2. Installation and Gate Identification Signs

Applicable N/A

Number of base standards 1

Image Tool 250 x 188



Type: **Primary, Secondary and Tertiary (Uses per UFC)**

Applies to: Group 1 Group 2 Group 3 Group 4 Other

Mfr: Custom

Color: Dark bronze, brushed aluminum, accents per UFC

Finish: Powder coat or vinyl sign face

Model #: Metal frame and panels, buff stone base

Other: White vinyl lettering. Provide dimensions per UFC. Secondary signs will match primary sign's materials, but will be smaller in size per UFC. Tertiary signs must follow the UFC.

UFGS: Section 05 50 13 Miscellaneous Metal Fabrications

C08.1.3. Building Identification Signs

Applicable N/A

Number of base standards 5

Image Tool 250 x 188

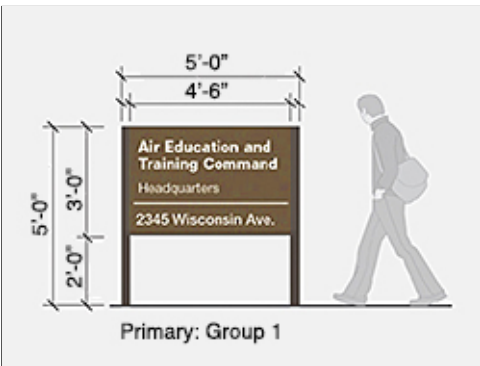

Type: **Freestanding Primary Sign (Sizes and Uses per UFC)**

Applies to: Group 1 Group 2 Group 3 Group 4 Other

Mfr: Custom

Color: Medium brown face, dark bronze posts, white vinyl lettering

Finish: Powder coat or vinyl sign face

Model #: Aluminum sheet face, extruded aluminum posts

Other: Provide layout and sizes per UFC.

UFGS: Section 05 50 13 Miscellaneous Metal Fabrications

Type: **Freestanding Secondary Sign (Sizes and Uses per UFC)**

Applies to: Group 1 Group 2 Group 3 Group 4 Other

Mfr: Custom

Color: Medium brown face, dark bronze posts, white vinyl lettering

Finish: Powder coat or vinyl sign face

Model #: Aluminum sheet face, extruded aluminum posts

Other: Provide layout and sizes per UFC.

UFGS: Section 05 50 13 Miscellaneous Metal Fabrications

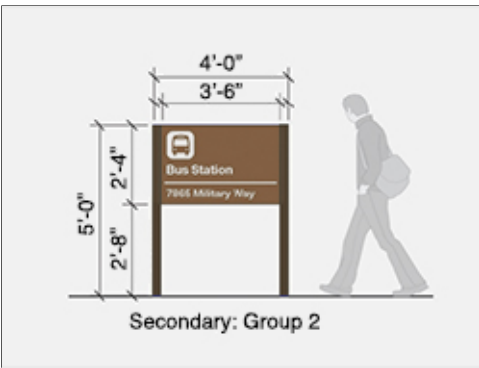

Type: **Freestanding Tertiary Sign (Sizes and Uses per UFC)**

Applies to: Group 1 Group 2 Group 3 Group 4 Other

Mfr: Custom

Color: Medium brown face, dark bronze posts, white vinyl lettering

Finish: Powder coat or vinyl sign face

Model #: Aluminum sheet face, extruded aluminum posts

Other: Provide layout and sizes per UFC.

UFGS: Section 05 50 13 Miscellaneous Metal Fabrications

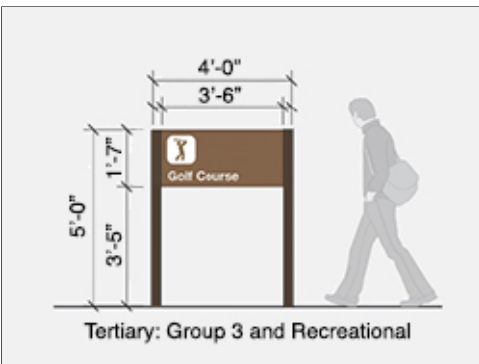

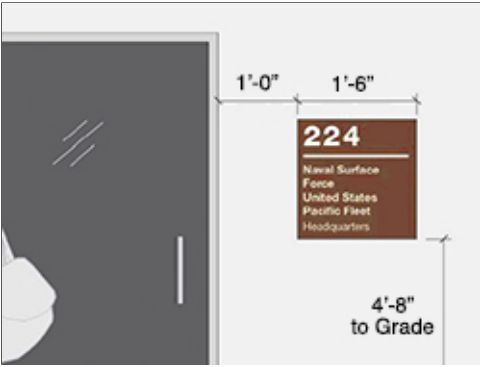

Type: **Wall Mounted**

Applies to: Group 1 Group 2 Group 3 Group 4 Other

Mfr: Custom

Color: Medium brown, white lettering

Finish: Satin vinyl applied to aluminum sheet

Model #: Aluminum sheet with vinyl face and vinyl lettering

Other: Provide layout and sizes following UFC.

UFGS: N/A



Type: **Glass Mounted**

Applies to: Group 1 Group 2 Group 3 Group 4 Other

Mfr: Custom

Color: White vinyl lettering

Finish: Matte vinyl

Model #: Machine-cut sheet vinyl

Other: Apply vinyl lettering to glass. Provide sizes following UFC.

UFGS: N/A

C08.1.4. Traffic Control Devices (Street Signs)

Applicable N/A Number of base standards 1

Image Tool 250 x 188



Type: **Street Signs**

Applies to: Group 1 Group 2 Group 3 Group 4 Other

Mfr: Custom

Color: White reflective lettering on a Standard Brown background

Finish: Powder coat or vinyl sign face

Model #: Aluminum sign face, control arm or pole mounted

Other: Mount 7' above grade minimum, pictographs and logos are prohibited on street name signs per UFC.

UFGS: Section 05 50 13 Miscellaneous Metal Fabrications

C08.1.5. Directional and Wayfinding Signs

Applicable N/A Number of base standards 2

Image Tool 250 x 188

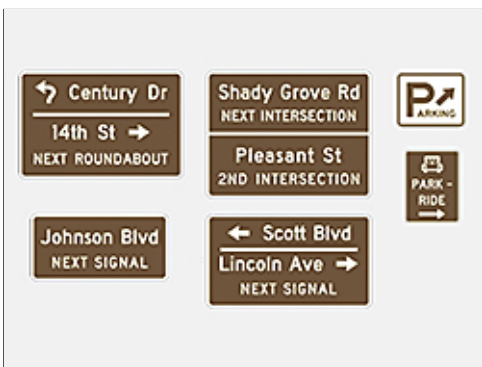

Type: **Vehicular**

Applies to: Group 1 Group 2 Group 3 Group 4 Other

Mfr: Custom

Color: Medium brown face, dark bronze posts, white reflective lettering

Finish: Powder coat or vinyl sign face

Model #: Aluminum sheet face, extruded aluminum posts

Other: Conform to the requirements of the MUTCD and its DoD Supplement. Provide types and sizes where required by UFC.

UFGS: Section 05 50 13 Miscellaneous Metal Fabrications

Type: **Pedestrian**

Applies to: Group 1 Group 2 Group 3 Group 4 Other

Mfr: Custom

Color: Medium brown face, dark bronze posts

Finish: Powder coat or vinyl sign face

Model #: Aluminum sheet face, extruded aluminum posts

Other: White vinyl lettering. Provide types and sizes where required by UFC.

UFGS: Section 05 50 13 Miscellaneous Metal Fabrications

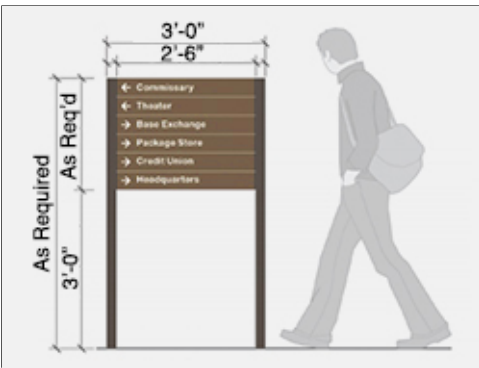

C08.1.6. Informational Signs

Applicable N/A Large graphics do not apply

Applicable N/A Small graphics do not apply

1. Minimize informational signs such as static display signs, hours of operation, and project signs to reduce visual clutter.
2. Static display signs will have standard National Park Service brown.
3. Hours of operation signs will have a level of quality equivalent to the Facility Group number.
4. Temporary / Project Signage will be judiciously placed to avoid visual clutter. Schedule and arrange for the removal of these signs prior to installation.

C08.1.7. Motivational Signage

Applicable N/A Large graphics do not apply

Applicable N/A Small graphics do not apply

1. Provide professionally produced motivational signs as important elements of campaigns to boost morale, improve safety, aid in recruiting, and accomplish other motivational objectives. Consolidate this signage to reduce visual clutter.
2. Motivational signs will be limited to an electronic "marquee" type changeable sign near each gate. Temporary signs are not permitted. Motivational information may also be posted in a small, printed format on kiosks in specified, high pedestrian use areas. Refer to kiosks under Site Furnishings.
3. Follow UFC 3-120-01 for color and layout. Note that animated, blinking, chasing, flashing, or moving effects are prohibited by the UFC.
4. Mount marquee signs on reinforced concrete bases with a natural warm gray color.

C08.1.8. Parking Lot Signs

Applicable N/A

C08.1.9. Regulatory Signs

Applicable N/A

1. Regulatory signage, which restricts, warns and advises, must be limited to those mandated under Highway/Traffic, Government Warning, and/or Parking Regulation. Follow UFC 3-120-01 and its industry references for color and layout.
2. Provide a comprehensive, systematic approach to regulatory signage to avoid clutter and confusion from "over signage."
3. Maintain base warning signs for safety and security at the base perimeter and at specific secure areas. Use these to notify visitors of restrictions governing conduct on the base, as well as other security procedures.

C08.1.10. Other

Applicable N/A

Not applicable

C09. LIGHTING

Comply with AF Corporate Standards for Site Development:
<http://afcs.wbdg.org/site-development/index.html>

Comply with AF Corporate Standards for Lighting:
<http://afcs.wbdg.org/site-development/lighting/index.html>

C09.1. Fixtures and Lamping

Applicable N/A Large graphics do not apply

Applicable N/A Select number of graphics / images (small: 250 px x 188 px) to insert 3

Image Tool 250 x 188



Balanced Interior-Exterior Lighting



Parking Lot Fixture



Wall-Mounted Fixture

1. Provide, coordinate and efficiently install street, parking lot, sidewalk and facility lighting with appropriate luminaires, lamping, placement and spacing following UFC 3-530-01 and Installation Facilities Standards (IFS); ensure the level of quality is consistent with the adjacent facility group number. Pole-mounted, wall-mounted and bollard fixtures are permitted.
2. Integrate controls to automatically reduce lighting power during periods of non-activity; automatically turn off power when sufficient daylight is available.

3. Ensure continuity and consistency of lighting elements. In new construction generally match post types, fixture types, styles, heights, sizes, materials, colors, and lamp types of adjacent facilities and the facility district.
4. Economically provide renewable-energy power sources such as solar photovoltaic when feasible.
5. Use appropriately designed or shielded luminaires to direct light downward to minimize light pollution and intrusion onto adjacent sites and to facilitate night training.
6. Calculate illuminant levels for all lighting applications following UFC 3-530-01 and ensure compliance with pre-curfew maximum brightness level requirements.
7. Sufficiently address environmental factors to prevent corrosion and weathering of fixtures, plinths and other components.
8. Wall mounted fixtures should respond to the architectural character of the facility.
9. Efficient accent lighting of architectural and landscape features may be provided for Group 1, lodging and historical applications. Accent lights in ground-mounted locations may be provided for static displays and signs when these do not conflict or cause hazards with overhead aircraft.
10. Comply with UFC 3-530-01 for light source technology and lamp types. High efficiency lamping such as LED is preferred for most applications.
11. Provide round tapered, square non-tapered, or round non-tapered aluminum poles and aluminum fixtures with square, rectangular or circular housings in colors and shapes to match adjacent facilities and the facility district.
12. Install lighted bollards only at Group 1 and high-traffic Group 2 facilities. Generally match materials, colors and shapes of adjacent facilities and the facility district.
13. Install natural warm gray color, smooth finished concrete bases for all poles in heights appropriate for the facility group and application. Generally Groups 1, 2 and 4 will have at-grade bases. Group 3 will have taller bases for added durability.
14. When parking lot lighting is necessary, provide an illuminated path to the building's main entrance. Pole bases should be contained within an internal landscape median or island.
15. Consistently install lighting for sidewalks, bikeways and trails to match adjacent facilities.
16. Landscape accent lighting may be used in public gathering spaces and in Group 1 facilities. Coordinate the design, luminaire selection, and placement with the location of trees, shrubs, and site furnishings.
17. Manufacturers listed below are only provided to establish a baseline of equivalency among all applicable manufacturers.

C09.2. Light Fixture Types

Note: Apply the below base-wide standards for Light Fixtures (products, materials and color). Then refer to the Appendix and apply any additional requirements specifically related to the Facility District in which the project is located.

C09.2.1. Street Lighting

Applicable N/A

Number of base standards 2

Image Tool 250 x 188

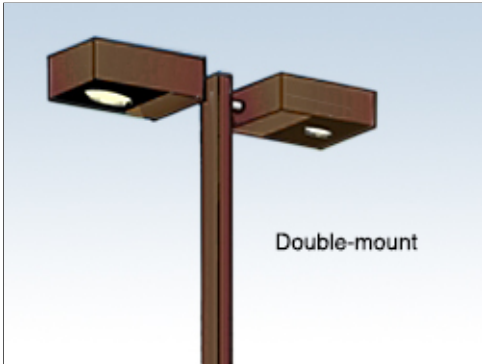

Type: **Style 1**

Applies to: Group 1 Group 2 Group 3 Group 4 Other

Mfr: Hubbell, Kim Lighting

Color: Dark Bronze Anodized (or Clear Anodized as approved by BCE)

Finish: Factory

Model #: Rectilinear Cutoff, Single Arm or Dual Arm Mount

Other: Lamp: LED. Follow manufacturer's recommendations for fixture base.

UFGS: N/A

Type: **Style 2**

Applies to: Group 1 Group 2 Group 3 Group 4 Other

Mfr: Hubbell, Kim Lighting

Color: Clear Anodized as approved by BCE

Finish: Factory

Model #: Round Cutoff, Single Arm or Dual Arm Mount

Other: Lamp: LED. Follow manufacturer's recommendations for fixture base.

UFGS: N/A

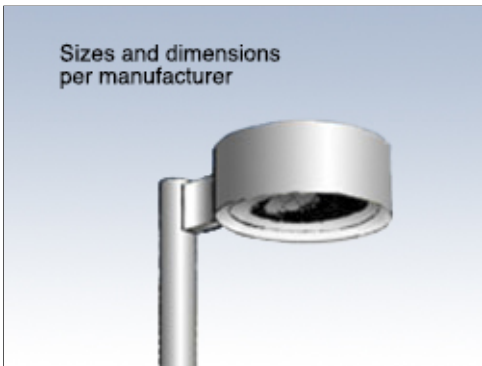

C09.2.2. Parking Lot Lighting

Applicable N/A

Number of base standards 2

Image Tool 250 x 188

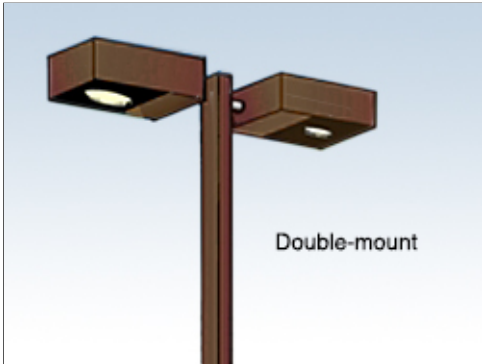

Type: **Parking Lot Style 1**

Applies to: Group 1 Group 2 Group 3 Group 4 Other

Mfr: Hubbell, Kim Lighting

Color: Dark Bronze Anodized (or Clear Anodized as approved by BCE)

Finish: Factory

Model #: Rectilinear or Round Cutoff, Single Arm or Dual Arm Mount

Other: Lamp: LED. Follow manufacturer's recommendations for fixture base.

UFGS: N/A

Type: **Parking Lot Fixture Base**

Applies to: Group 1 Group 2 Group 3 Group 4 Other

Mfr: Custom

Color: Natural gray

Finish: Trowel

Model #: Form-cast, round

Other: N/A

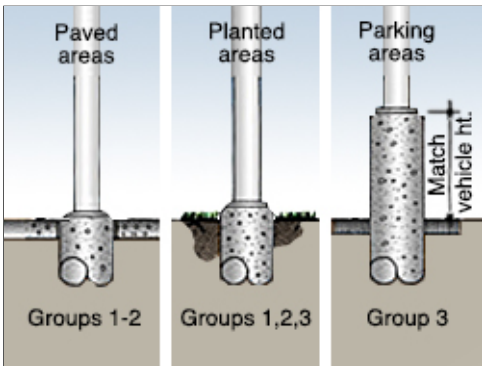

UFGS: Section 03 33 00 Cast-In-Place Architectural Concrete

C09.2.3. Lighted Bollards

Applicable N/A

Number of base standards 2

Image Tool 250 x 188



Type: **Lighted Round Dome Top**

Applies to: Group 1 Group 2 Group 3 Group 4 Other

Mfr: Lithonia Lighting Products

Color: Dark Bronze

Finish: Anodized aluminum

Model #: KBA

Other: Flared cone, 3000K LED Lamp. Follow manufacturer's recommendations for fixture base.

UFGS: N/A

Type: **Lighted Round**

Applies to: Group 1 Group 2 Group 3 Group 4 Other

Mfr: Dura Art Stone

Color: Weatherstone Gray with Silver shield

Finish: Textured precast / anodized aluminum

Model #: Rock aggregate

Other: 3000K LED Lamp, 360° downlighting

UFGS: N/A



C09.2.4. Sidewalk Lighting

Applicable N/A

Number of base standards 1

Image Tool 250 x 188

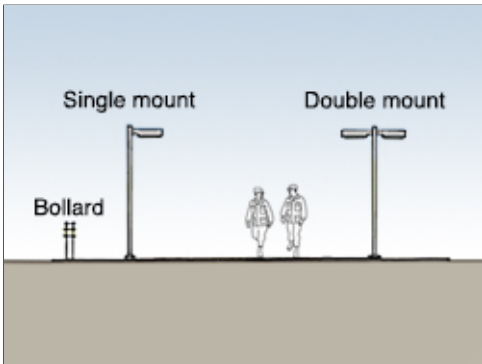

Type: **Rectilinear Cutoff**

Applies to: Group 1 Group 2 Group 3 Group 4 Other

Mfr: Hubbell, Kim Lighting

Color: Dark Bronze Anodized (or Clear Anodized as approved by BCE)

Finish: Anodized aluminum

Model #: Rectilinear Cutoff, Single Arm or Dual Arm Mount

Other: Lamp: LED. Follow manufacturer's recommendations for fixture base.

UFGS: N/A

C09.2.5. Walls / Stairs Lighting

Applicable N/A

Number of base standards 1

Image Tool 250 x 188



Type: **Style 1**

Applies to: Group 1 Group 2 Group 3 Group 4 Other

Mfr: Vista Lighting

Color: Dark bronze anodized

Finish: Smooth

Model #: Aluminum Step and Brick Lights, 5230 round louvered

Other: Lamp: LED

UFGS: N/A

C09.2.6. Other

Applicable N/A

D. FACILITIES EXTERIORS

Comply with Air Force Corporate Standards for Facilities Exteriors:

<http://afcfs.wbdg.org/facilities-exteriors/index.html>

Applicable N/A Large graphics do not apply

Applicable N/A Small graphics do not apply

D01. SUPPORTING THE MISSION

Comply with AF Corporate Standards for Supporting the Mission:

<http://afcfs.wbdg.org/facilities-exteriors/supporting-the-mission/index.html>

D02. SUSTAINABILITY

Comply with Air Force Corporate Standards for Sustainability:

<http://afcfs.wbdg.org/facilities-exteriors/supporting-the-mission/index.html>

D03. ARCHITECTURAL FEATURES

Comply with AF Corporate Standards for Facilities Exteriors:

<http://afcs.wbdg.org/facilities-exteriors/index.html>

Comply with AF Corporate Standards for Architectural Features:

<http://afcs.wbdg.org/facilities-exteriors/architectural-features/index.html>

Insert 3 photos for each facility group.

Image Tool 250 x 188

Group 1



Group 2



Group 3



Group 4



D03.1. Orientation, Massing and Scale

1. Orient new buildings to maximize energy efficiency, passive solar and daylighting potential of the building; narrow buildings oriented along an east-west axis are preferred to minimize heat gain in the summer months and maximize heat gain in the winter months resulting in less overall energy usage.
2. Provide orthogonal geometry for principal building form; angular geometry may be used sparingly for Group 1 and used only for emphasis at specific areas such as building entrances and stairwells.
3. Maintain a human scale and reduce the visual scale of large buildings with sub-massing related to interior functional operations; create consistent form and scale in adjacent buildings with compatible profiles or silhouettes.
4. Building heights will not be limited; however, building heights over 2 stories will be considered on a case-by-case basis.
5. Combine functions where practical to avoid a proliferation of small, independent structures.
6. Use and coordinate shading devices with orientation and for function.

Applicable N/A Large graphics do not apply

Applicable N/A Small graphics do not apply

D03.2. Architectural Character

1. Develop architectural features, materials and detailing appropriate for the Facility Group designation. Refer to Building Entrances, Wall Systems and Roof Systems.
2. Respond to the local climate and regional influences with environmentally functional architectural features.
3. For new facilities design generally maintain consistency and visual unity in the character of the adjacent buildings through compatible architectural features: repeated use of similar forms such as roofs, and through recurring elements such as doors, windows, materials and colors.
4. Reinforce the military transport theme with a related architectural theme expressive of innovation and technology that represents the current mission at Dover AFB.
5. All facilities will express sustainability through their orientation, massing, shape, form, materials, and detailing. Provide louvers, fins and other shading devices to control heat gain and glare and to and improve energy efficiency.
6. Strive for economical construction without compromising a high-quality, professional appearance.

Ensure architectural compatibility through the use of consistent materials such as concrete masonry units (CMU), brick, and Exterior Insulation Finish Systems (EIFS). Please refer to Section D05.4 Wall Systems Materials and D07.9. Roof Systems Materials for a detailed listing of materials.

Applicable N/A Large graphics do not apply

Applicable N/A Small graphics do not apply

D03.3. Details and Color

1. Provide a palette of approved Dover AFB colors in brick, block, EIFS and powder-coated metals. Refer to Section D05.4 Wall Systems Materials and D07.9. Roof Systems Materials for a detailed listing of colors and other details.

2. Relate the level of architectural detailing to the Facility Group number.
3. Use only integrally colored materials as the predominant exterior building material; do not use materials that require field painting and ongoing maintenance.
4. Provide consistent and compatible colors for every exterior building feature, including walls, roofs, doors, windows, gutters, downspouts, utility and mechanical elements, and other visible elements.
5. Noncorrosive metals with factory applied color finishes are required.
6. Combine details and color with orientation, massing, scale and architectural character to maintain base compatibility.
7. Manufacturers listed below are only provided to establish a baseline of equivalency among all applicable manufacturers.
 - Applicable N/A Large graphics do not apply
 - Applicable N/A Small graphics do not apply

D03.3.1. Climate-based Data and Life-Cycle Cost-Effective Passive and Natural Design Strategies:

- Climate dominated by mechanical cooling
- Climate dominated by mechanical heating
- Climate with similar mechanical cooling / heating needs
- Climate with minimal mechanical cooling / heating needs

- Climate with high humidity
- Climate with moderate humidity
- Climate with low humidity

- High Solar Insolation
- Moderate Solar Insolation
- Low Solar Insolation

- Soils with High Thermal Conductivity
- Soils with Average Thermal Conductivity
- Soils with Low Thermal Conductivity

Other: Consider the potential for flooding and corrosion.

Other:

Facility: Narrow buildings along E-W axis are preferred

Wall: Integral shading features and devices / interior masonry thermal mass walls (for cooling)

Doors: Recessed are preferred

Windows: Provide insulating glazing on north-facing windows / maximize shading for windows on south façades.

Roof: High to medium albedo, moderate slope for all buildings except hangars / large industrial facilities

Structure: Do not expose ferrous metals. Provide factory finished non-ferrous metals or concrete

MEP: Ground-source following LCCA

Other: Internal thermal mass walls may be used for cooling following LCCA.

Other: Active skin systems / active shading devices are permitted following LCCA.

Note: Apply the below base-wide standards for Architectural Features (products, materials and color). Then refer to the Appendix and apply any additional requirements specifically related to the Facility District in which the project is located.

D03.3.2. Natural Ventilation System

Applicable N/A Number of base standards 1

Image Tool 250 x 188



Type: **Style 1 Aluminum Windows**

Applies to: Group 1 Group 2 Group 3 Group 4 Other

Mfr: Kawneer (or equivalent)

Color: Dark Bronze (or clear anodized as approved by BCE)

Finish: Anodized

Model #: 2x4, slider or awning type

Other: Provide thermally broken frames.

UFGS: Section 08 41 13 Aluminum-Framed Entrances and Storefronts

D03.3.3. Thermal Mass

Applicable N/A

Number of base standards 1

Image Tool 250 x 188



Type: **Style 1 Interior Wall Material**

Applies to: Group 1 Group 2 Group 3 Group 4 Other

Mfr: Custom, TBD

Color: Red brick blend

Finish: Light texture

Model #: Coursed unit masonry

Other: Brick is preferred. Concrete block may only be used in Group 3 when approved by the BCE.

UFGS: Section 04 20 00 Unit Masonry

D03.3.4. Thermal Shading

Applicable N/A

Number of base standards 1

Image Tool 250 x 188



Type: **Style 1 Wall Devices**

Applies to: Group 1 Group 2 Group 3 Group 4 Other

Mfr: Kawneer (or equivalent) or custom

Color: Dark bronze

Finish: Factory, to match frames

Model #: Louver

Other: Shading devices may be attached to frames or structure

UFGS: Section 08 41 13 Aluminum-Framed Entrances and Storefronts

D03.3.5. Renewable Heating/Cooling

Applicable N/A

D03.3.6. Solar Photovoltaic System

Applicable N/A

D03.3.7. Solar Thermal System

Applicable N/A

D04. BUILDING ENTRANCES

Comply with AF Corporate Standards for Facilities Exteriors:

<http://afcs.wbdg.org/facilities-exteriors/index.html>

Comply with AF Corporate Standards for Building Entrances:

<http://afcs.wbdg.org/facilities-exteriors/building-entrances/index.html>

Insert 3 photos for each facility group.

Image Tool 250 x 188

Group 1



Group 2



Group 3



Group 4



D04.1. Primary Entrances

1. Emphasize the primary entrance in the overall building design with a projecting or recessed covering for weather protection following Installation Facilities Standards (IFS) for Facility Group designations.
2. Provide vestibules at entries in Groups 1, 2 and 3 unless used infrequently or serving unconditioned space following ASHRAE 90.1.
3. Fully integrate all elements including the design of handicap ramps in the overall design of the primary entrance in an organized uncluttered appearance.
4. Install paved transitional spaces sized for the building function and occupancy.
5. Install appropriate lighting and site furniture following AT and IFS.
6. Protect entrances from falling snow and ice.
7. Provide porte cocheres or covered drop-offs when justified for lodging and medical facilities; do not use for prestige or architectural accents.

D04.2. Secondary Entrances

1. Provide vestibules at entries in Groups 1, 2 and 3 unless used infrequently or serving unconditioned space following ASHRAE 90.1; use of stair towers as vestibules for multi-story buildings is encouraged when building and / or energy codes are satisfied.
2. Reflect the character of the primary entrance to a lesser extent with a smaller scale.
3. Include a recess or projection for weather protection and shading.
4. Integrate service and egress doors and loading areas with the building design by matching the materials and detailing and reflect the overall quality of the facility.
5. Incorporate egress structures such as stair towers into the facility design.
6. Canopies may be used for service and loading areas; weather protection beyond weatherstripping is not required at doors used only for life safety egress.
7. Develop building massing and orientation to minimize the appearance of service and loading areas; physically and visually separate these from primary entrances.
8. Loading areas must be organized, orderly and have an uncluttered appearance.

D05. WALL SYSTEMS

Comply with AF Corporate Standards for Facilities Exteriors:

<http://afcs.wbdg.org/facilities-exteriors/index.html>

Comply with AF Corporate Standards for Wall Systems:

<http://afcs.wbdg.org/facilities-exteriors/wall-systems/index.html>

Comply with AFCFS Recommended Materials:

<http://afcs.wbdg.org/facilities-exteriors/wall-systems/materials/index.html>

Insert 3 photos for each facility group.

Image Tool 250 x 188

Group 1



Group 2



Group 3



Group 4



D05.1. Hierarchy of Materials

1. Group 1 facilities may have more refined detailing than Group 2 and Group 2 may have more definition than Group 3.
2. Group 1 and 2 facilities will be a combination of; Dover Tan standard-size and may use exterior insulation finish system for subtle accents to brick. Use header, rowlock, and soldier coursing with corbelling, relief or other accents to create shadow lines. Brick and architectural precast may be used also. Metal insulated sandwich panels is acceptable for Group 3 facilities and inconspicuous areas of Group 2 facilities. Refer to the Appendix for special requirements of Facility Districts.
3. Group 1 facilities will promote the use of relief in brick surfaces creating shadow lines; Conceal expansion joints with downspouts or locate them at transitions in the wall such as at pilasters or reveals.
4. Group 4 will be a combination of two of the following materials: brick and horizontal siding.
5. Multi-story Group 1 facilities may include a transition in material, color or detailing to create a visual base. Generally limit brick and exterior insulation finish systems to a single color on Group 2, 3 and 4 facilities.
6. Use high-performance building envelopes following UFC 1-200-02.
7. Use detailing not subject to excessive weathering. Provide wall accents consistently throughout the base.
8. Use integrally colored materials and factory-finished metals. Do not paint concrete block.
9. Translucent wall panels may be used in Facility Group 1 and Group 2 when protected from direct solar gain. Provide insulating panels and shading appropriate for the orientation and exposure.
10. Manufacturers listed below are only provided to establish a baseline of equivalency among all applicable manufacturers.
11. DAFB Decorative Concrete Masonry Units: Split-face and smooth decorative concrete masonry units will be as manufactured by Fizzano Brothers Concrete Masonry Products, Inc., 1776 Chester Pike, Crum Lynne, PA 19022, (Color Number F-1054C), or New Holland Concrete, New Holland, PA, (Color Number N1162), or approved equal. Mortar color will be natural Portland cement with no color additives.
12. DAFB Brick Masonry Units: Brick will be as manufactured by the Belden Brick Company, Canton, OH, (Color Number 8521), or General Shale Plymouth, (Color Number 39-10-050-0), or Glen-Gary, (Color Number R83), or approved equal. Mortar color will be natural Portland cement with no color additives.
13. DAFB Exterior Insulation Finish System (EIFS). Approved colors will be either Dryvit #111 "Prairie Clay" in Sandpebble or Sandblast texture or Sto Classic Color Collection #93860 "Sandstone" in Medium 1.5 or Fine 1.0 texture. Other colors require prior approval by Dover AFB.

D05.2. Layout, Organization and Durability

1. Organize wall components including doors, windows, accents, shading devices, control joints, etc., to provide an ordered, professional appearance.
2. Integrate shading devices into the overall composition of the wall.
3. Integrate fixed shading devices at all exterior glazing exposed to summer UV heat gain as a passive design measure to reduce energy use. Ensure adequate shading at west entrances. Deciduous trees may be used for shading.
4. Shading systems may be included as part of a manufacturer's window system or may be custom systems integrated into the wall.
5. Provide appropriate transitions between dissimilar materials to mitigate effects of thermal expansion and galvanic action.
6. All joint sealants will be slightly darker than adjacent surfaces.
7. Materials requiring regular maintenance are not permitted; do not use exposed structural steel or other materials that require painting.

8. Refer to C07.2.16. Screen Walls for materials and colors of freestanding walls.

9. Refer to D07. Roofs for downspouts.

D05.3. Equipment, Vents and Devices

1. Arrange all mechanical, electrical, fire alarm, lightning protection and other system components to create an orderly appearance that integrates with the wall system.

2. Do not expose conduits, cables, piping, lightning protection components, etc. on exterior walls; if unavoidable in renovations, finish these elements to match the adjacent wall surface.

3. Avoid visual clutter and where surface-mounted elements are required they will match the wall color.

D05.4 Wall Systems Materials

Facility Group 1 wall materials will be as follows.

Primary: Brick

Secondary: Architectural Precast

Accent: Optional: EIFS

Facility Group 2 wall materials will be as follows.

Primary: Brick and EIFS

Secondary: Architectural precast

Accent: Optional: Cast-in-Place Concrete

Facility Group 3 wall materials will be as follows.

Primary: Insulated Metal Sheeting

Secondary: Brick

Accent: Optional: Brick

Facility Group 4 wall materials will be as follows.

Primary: Fiber Cement Siding

Secondary: Fiber Cement Siding, Trim Boards

Accent: Concrete or Brick Foundation Cladding

Note: Apply the below base-wide standards for Wall Systems (products, materials and color). Then refer to the Appendix and apply any additional requirements specifically related to the Facility District in which the project is located.

D05.4.1. Flat Metal Panels

Applicable N/A

Number of base standards 1

Image Tool 250 x 188



Type: **Style 1**

Applies to: Group 1 Group 2 Group 3 Group 4 Other

Mfr: Alucobond

Model #: Alucobond Classic, Rainscreen I

Color: Anodic Clear Mica PVDF 2

Finish: Matte

Other: Route and Return Dry Seal

UFGS: Section 07 42 13 Metal Wall Panels:
<http://www.wbdg.org/FFC/DOD/UFGS/UFGS 07 42 13.pdf>
Section 07 42 63 Fabricated Wall Panel Assemblies:
<http://www.wbdg.org/FFC/DOD/UFGS/UFGS 07 42 63.pdf>

D05.4.2. Brick Veneer

Applicable N/A

Number of base standards 1

Image Tool 250 x 188



Type: **Style 1**

Applies to: Group 1 Group 2 Group 3 Group 4 Other

Mfr: Belden Brick or General Shale Plymouth or Glen-Gary

Model #: 2.6x4x8 nominal, face brick

Color: #8521A (Tan); #39-10-050-0 - Royal Grey Velour; #R83 - Boulder Grey

Finish: Straight Edges, smooth texture

Other: Mortar color will be natural Portland cement with no color additives.

UFGS: Section 04 20 00 Unit Masonry:
<http://www.wbdg.org/FFC/DOD/UFGS/UFGS 04 20 00.pdf>

D05.4.3. Architectural Precast

Applicable N/A Number of base standards 1

Image Tool 250 x 188



Type: **Style 1, Smooth Casting**

Applies to: Group 1 Group 2 Group 3 Group 4 Other

Mfr: Local, TBD

Model #: Smooth Casting

Color: Light Beige

Finish: Very Light texture

Other: N/A

UFGS: Section 03 45 00 Precast Architectural Concrete:
<http://www.wbdg.org/FFC/DOD/UFGS/UFGS 03 45 00.pdf>

D05.4.4. Stucco Over Sheathing

Applicable N/A

D05.4.5. Curtain Wall

Applicable N/A

D05.4.6. Cast-In-Place Concrete

Applicable N/A

D05.4.7. Tilt-Up Concrete

Applicable N/A

D05.4.8. Ribbed Metal Sheeting

Applicable N/A Number of base standards 1

Image Tool 250 x 188



Type: **Flush Seam Panel**

Applies to: Group 1 Group 2 Group 3 Group 4 Other

Mfr: Berridge

Model #: Flush Seam Panel

Color: Beige (match ICI Devoe Pastel Tint Base #BLK 1P32 YOX 1P39 OXR 19)

Finish: Embossed Texture, factory finished

Other: 24 Gauge Steel

UFGS: Section 07 42 13 Metal Wall Panels:
<http://www.wbdg.org/FFC/DOD/UFGS/UFGS 07 42 13.pdf>

D05.4.9. EIFS

Applicable N/A Number of base standards 2

Image Tool 250 x 188



Type: **Style 1**

Applies to: Group 1 Group 2 Group 3 Group 4 Other

Mfr: Dryvit

Model #: "Outsulation" System

Color: #111 "Prairie Clay"

Finish: "Sandpebble" or sandblast texture

Other: Other colors require prior approval by Dover AFB

UFGS: Section 07 24 00 Exterior Insulation and Finish Systems:
<http://www.wbdg.org/FFC/DOD/UFGS/UFGS 07 24 00.pdf>

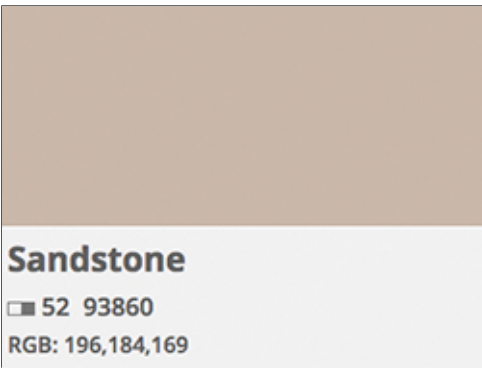

Type: **Style 2**

Applies to: Group 1 Group 2 Group 3 Group 4 Other

Mfr: Sto

Model #: Insulated Wall Cladding

Color: Sto Classic Color Collection #93860 "Sandstone"

Finish: Medium 1.5 or Fine 1.0 texture

Other: Other colors require prior approval by Dover AFB

UFGS: Section 07 24 00 Exterior Insulation and Finish Systems:
<http://www.wbdg.org/FFC/DOD/UFGS/UFGS 07 24 00.pdf>

D05.4.10. GFRC

Applicable N/A

D05.4.11. Concrete Block

Applicable N/A Number of base standards 2

Image Tool 250 x 188



Type: **Concrete Masonry Units (CMU): Split Face**

Applies to: Group 1 Group 2 Group 3 Group 4 Other

Mfr: Fizzano Brothers Concrete or New Holland Concrete

Model #: 8x8x16 nominal, face and corner units

Color: Fizzano Color Number F-1054C or New Holland Color Number N1162

Finish: Heavy texture

Other: Mortar color will be natural Portland cement with no color additives.

UFGS: Section 04 20 00 Unit Masonry:
<http://www.wbdg.org/FFC/DOD/UFGS/UFGS 04 20 00.pdf>

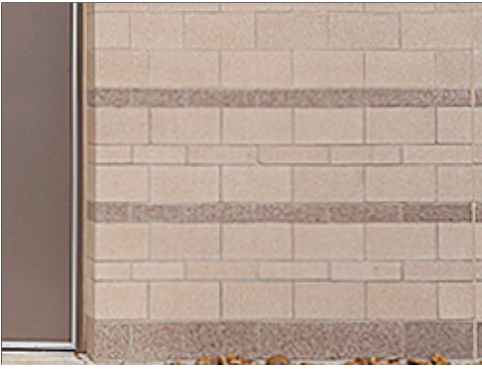

Type: **Concrete Masonry Units (CMU): Ground Face**

Applies to: Group 1 Group 2 Group 3 Group 4 Other

Mfr: Fizzano Brothers Concrete or New Holland Concrete

Model #: 8x8x16 nominal, face and corner units

Color: Fizzano Color Number F-1054C or New Holland Color Number N1162

Finish: Smooth Texture

Other: Mortar color will be natural Portland cement with no color additives.

UFGS: Section 04 20 00 Unit Masonry:
<http://www.wbdg.org/FFC/DOD/UFGS/UFGS 04 20 00.pdf>

D05.4.12. Fiber Cement Siding

Applicable N/A Number of base standards 1

Image Tool 250 x 188



Type: **Hardie Plank, Hardie Shingleyle 1**

Applies to: Group 1 Group 2 Group 3 Group 4 Other

Mfr: James Hardie Building Products, Inc.

Model #: Horizontal Lap Siding, Shingle Siding

Color: Earth Tones

Finish: Wood Texture

Other: Hardie Plank, Hardie Shingle

UFGS: SECTION 074646 Fiber Cement Siding:
(Not Available on UFGS)

D05.4.13. Other

Applicable N/A

D06. DOORS AND WINDOWS

Comply with AF Corporate Standards for Facilities Exteriors:

<http://afcs.wbdg.org/facilities-exteriors/index.html>

Comply with AF Corporate Standards for Doors and Windows:

<http://afcs.wbdg.org/facilities-exteriors/doors-and-windows/index.html>

Comply with AFCFS Recommended Materials:

<http://afcs.wbdg.org/facilities-exteriors/doors-and-windows/materials/index.html>

Insert 3 photos for each facility group.

Image Tool 250 x 188

Group 1



Group 2



Group 3



Group 4



D06.1. Types

1. Clear anodized aluminum doors, windows and frames with thermal breaks are preferred for Facility Groups 1-3 because they show less wear and weathering than dark anodized finishes; match the color of the door and frame. For renovation projects the color of new windows, doors and frames may match the existing ones.
2. Aluminum clad wood windows are preferred for Facility Group 4.
3. Standard-sized hinged doors are preferred. Use sliding, folding, overhead, sectional and other door configurations only to support mission operations.
4. Automatic doors are allowed only where functionally necessary.
5. Limit hollow metal doors and frames to security doors, utility rooms and mechanical rooms in Groups 1 and 2 and to any application in Group 3 facilities.
6. Exterior hollow metal doors will have factory flush tops constructed of factory installed and welded inverted metal channels, not retrofitted with sealed inserts. Provide thermally broken frames. Specify exterior rain drips on door head frames and at bottom of doors. Provide metal thresholds (ADA compliant when required) of a minimum width to match the adjacent door jamb and integral raised dam with vinyl insert to seal against windblown rain. Exterior doors serving common use areas will be provided with closures and integral hold open feature.
7. Utility and emergency egress doors will match the wall color.
8. Passive thermal comfort methods of ventilation are encouraged where life cycle cost justified.
9. Windows must meet force protection requirements.
10. Adjacent joint sealants should be slightly darker than the frame color.
11. Manufacturers listed below are only provided to establish a baseline of equivalency among all applicable manufacturers.

D06.2. Layout and Geometry

1. Visually and functionally compose openings in walls for the climate-specific exposure.
2. Consistently use opening type, size, placement, mullion pattern, and color to reinforce the overall architectural design.
3. Openings will augment interior lighting and space conditioning needs.
4. Protect against vandalism, intrusion and coordinate sound ratings.

D06.3. Glazing and Shading

1. Tinted, energy-efficient, low-e, double-pane glazing is encouraged; provide triple-pane glazing in extreme environments.
2. Glazing color will follow Installation Facilities Standards (IFS).
3. Translucent wall panels may be integrated into wall systems.
4. Do not use mirrored glazing.
5. Fully integrate applicable shading designs for overhangs, louvers, light shelves and grilles.
6. Where appropriate, install window screens to take advantage of natural ventilation.

D06.4. Hardware

1. Provide hardware appropriate for the Facility Group while considering activity and frequency of use and local climate; hardware may be of higher visual quality for Facility Group 1.

2. Ensure hardware will perform throughout the facility's lifespan without showing extreme wear.
3. Select finishes that will not degrade by intensity of operation or exposure to the elements.
4. Use consistent finishes and color on window and door systems throughout a facility. For renovation projects the color of new hardware may match the existing hardware.
5. Design building systems to eliminate the need for security screens whenever possible.

D06.5. Doors and Windows Materials

Note: Apply the below base-wide standards for Doors and Windows (products, materials and color). Then refer to the Appendix and apply any additional requirements specifically related to the Facility District in which the project is located.

D06.5.1. Anodized Aluminum

Applicable N/A Number of base standards 1

Image Tool 250 x 188



Type: **Anodized Aluminum Doors, Windows and Frames**

Applies to: Group 1 Group 2 Group 3 Group 4 Other

Mfr: Kawneer (or equivalent)

Color: Dark Brown Anodized

Finish: Matte

Model #: 2x4

Other: Provide thermally broken frames

UFGS: Section 08 41 13 Aluminum-Framed Entrances and Storefronts:
<http://www.wbdg.org/FFC/DOD/UFGS/UFGS 08 41 13.pdf>

D06.5.2. Hollow Metal

Applicable N/A

Number of base standards 1

Image Tool 250 x 188



Type: **Hollow Metal Doors, Windows and Frames**

Applies to: Group 1 Group 2 Group 3 Group 4 Other

Mfr: Hollow Metal Doors, Windows and Frames

Color: Eagle Feather Tan (Dover Tan)

Finish: Powder Coated, Satin

Model #: 2x4 frame, welded and grouted solid

Other: ICI Devoe Pastel Tint Base #BLK 1P32 YOX 1P39 OXR 19. When used at main entrances, doors will be Bald Eagle Brown (Dark Bronze) - ICI Devoe #4216-7460. Comply with D06.1.

UGFS: Section 08 11 13 Steel Doors and Frames:

<http://www.wbdg.org/FFC/DOD/UGFS/UGFS 08 11 13.pdf>

D06.5.3. Aluminum-clad Wood

Applicable N/A

D06.5.4. Other

Applicable N/A

D07. ROOF SYSTEMS

Comply with AF Corporate Standards for Facilities Exteriors:

<http://afcs.wbdg.org/facilities-exterior/index.html>

Comply with AF Corporate Standards for Roof Systems:

<http://afcs.wbdg.org/facilities-exterior/roof-systems/index.html>

Comply with AFCFS Recommended Materials:

<http://afcs.wbdg.org/facilities-exterior/roof-systems/materials/index.html>

Insert 3 photos for each facility group.

Image Tool 250 x 188

Group 1

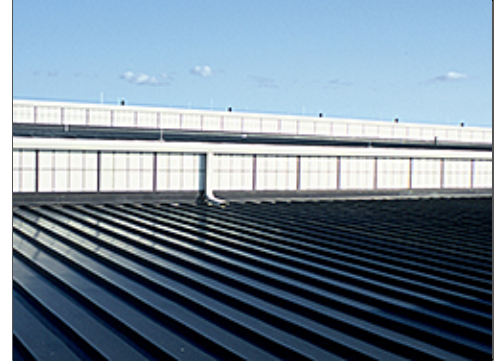

Group 2



Group 3



Group 4



D07.1. Roof Type and Form

1. Use proven, cost-effective roof systems with high durability, weather resistance, and low maintenance that are compatible with Installation Facilities Standards (IFS) and requirements for the designated Facility Group.
2. Generally match the roof type and form of existing adjacent facilities in new construction.
3. Group 1 and 2 buildings will use sloped standing seam metal roofs. Minimal-slope roofs may be used as approved on a case-by-case basis.
4. Provide screens for roof-mounted appendages and equipment of the same materials, which are used predominantly in the building's roof systems.
5. Group 2 and 3 facilities under 5,000 sf and narrow in plan geometry, may use low-sloped shed, gabled or hipped standing seam metal roofs. Larger facilities may use sloped-roof features in conjunction with predominantly minimal-sloped "flat" membrane roofs.
6. Group 4 facilities will have gabled or hipped composite shingle roofs.
7. Roof eaves will extend beyond the exterior wall for roof drainage and shading. Provide overhangs for shading in response to local climatic conditions, sized and proportioned to the height of the facility and to the window openings being shaded.
8. South-facing eaves will coordinate with adjacent wall-mounted shading devices.
9. The color, shape and slope of the eave and soffit will be compatible with adjacent facilities.
10. Keep roofs uncluttered and minimize penetrations.
11. Diminish massive roofs into coordinated smaller components consistent with adjacent facilities; avoid random, arbitrary changes.
12. Increase the insulation value of existing roofing systems during renovations if supported by life cycle cost and structural analysis.
13. Roofs must be maintained for the life of the system and replaced in accordance with UFC 3-110-04 and AFI 32-1051. A warranty is required on all new roofs.
14. Manufacturers listed below are only provided to establish a baseline of equivalency among all applicable manufacturers.

D07.2. Roof Slope

1. Group 1 and 2 buildings will use sloped roofs, min. 3:12.
2. Low-sloped roofs are allowed for larger structures or to match existing conditions on renovation projects. Minimal-sloped roofs may also be used for Group 3 facilities in high-visibility areas.
3. Group 4 facilities will use 4:12 to 6:12 roof slopes.
4. Ensure adequate drainage, and connect to the subsurface rain collection system where available.
5. Provide roof slopes to accommodate solar photovoltaic, solar thermal, passive systems and daylighting when applicable following UFC 1-200-02.
6. Provide underlayments as required for the roofing type as directed by the UFC.

D07.3. Parapets and Copings

1. Extend wall materials vertically above the roof line and provide metal copings to match the wall. Ensure copings are properly flashed and detailed to avoid roof leaks.

D07.4. Color and Reflectivity

1. Sloped roofs in Groups 1 and 2 and smaller facilities in Group 3 will be dark bronze to match adjacent facilities and follow requirements of IFS.
2. All minimal-slope membrane roofs will use only use high-albedo, high reflectivity color to help decrease the temperature around the buildings and minimize damage to human and wildlife habitat.
3. Sloped roofs in Group 4 will be earth tones.
4. Comply with UFC 3-110-03 and ASHRAE 90.1 for Solar Reflectance Index (SRI) and thermal requirements.
5. All roof flashing will match the color of the predominant background material.

D07.5. Gutters, Downspouts, Scuppers, Drains

1. All sloped roofs will use gutters and downspouts. Gutters will be outside the fascia.
2. Internal roof drainage systems are not permitted in new construction. Minimal-sloped roofs will be sloped to drain to the building perimeter through scuppers into downspouts.
3. All gutters and fascias will match the roof color.
4. Size the roof drainage system per IBC and SMACNA for the region.
5. Use scuppers as required in parapet walls. Arrange scuppers in an orderly manner consistent with other elements of the wall system.
6. When open scuppers are connected to downspouts, provide transitions consistent with adjacent facilities.
7. Integrate downspouts with the architectural details of the wall system and arrange in an orderly, non-prominent appearance. Generally blend downspouts with the color of the wall (not contrasting it).
8. Fabricate downspouts from non-corrosive materials such as aluminum or zinc-coated steel. Provide powder-coated finishes in medium bronze.
9. All downspouts will be solid.
10. Provide angled transitional pieces for downspouts to fit closely against the wall for their entire length.
11. Coordinate locations of downspouts to conceal control joints in masonry walls when possible.
12. Place downspouts away from building entries. Water discharged should not run across sidewalks.

D07.6. Roof Vents and Elements

1. Minimize and consolidate roof penetrations into a single, inconspicuous point whenever possible.
2. On sloped roofs clad pipe penetrations and coordinate color to match the roofing material.
3. Avoid the use of rooftop mechanical equipment, however for renovations and unavoidable configurations ensure units are screened to match the roofing material.
4. Provide access points and service routes to equipment that protect the roof.
5. Screen all large vents.
6. Ensure attic spaces are properly vented at ridges and soffits.

7. Match roof color for all exposed equipment and vents.
8. Avoid roof-mounted antenna systems.
9. Arrange Lightning Protection Systems (LPS) components in an ordered, uncluttered, inconspicuous appearance and integrated into the organization of the roof and wall systems.
10. Ensure that LPS roof mounting systems are approved by the roofing manufacturer.
11. Additions to a roof must not interfere with LPS or other rooftop systems that may be required.
12. Permanent fall protection must be included with any addition to a roof with a slope above 3:12 per UFC 3-110-03 to a roof with a slope above 3:12 per UFC 3-110-03.

D07.7. Clerestories and Skylights

1. Clerestories and skylights are permitted in Group 1 facilities. These are allowed in Group 3 facilities only when serving passive systems and are justifiable by life-cycle analysis.
2. Clerestories are preferred to skylights to avoid roof penetrations. Skylights, when permitted, must be simple in shape and integrated with the roof system to eliminate leakage.
3. Design clerestories and skylights using the same principles for seasonal shading that are required for walls and roof overhangs.
4. Translucent panel systems are preferred in clerestory applications due to lack of window cleaning.
5. Clerestories and skylights must comply with UFC 4-10-01.

D07.8. Vegetated Roof

1. Not applicable.

D07.9. Roof Systems Materials

Note: Apply the below base-wide standards for Roof Systems (products, materials and color). Then refer to the Appendix and apply any additional requirements specifically related to the Facility District in which the project is located.

D07.9.1. Standing Seam Metal

Applicable N/A

Number of base standards 1

Image Tool 250 x 188



Type: **Style 1**

Applies to: Group 1 Group 2 Group 3 Group 4 Other

Mfr: Berridge

Color: Dark bronze

Finish: Matte

Model #: Tee-Panel

Other: Shed, gabled or hipped standing seam metal

UFGS: Section 07 61 14 Steel Standing Seam Roofing
<http://www.wbdg.org/FFC/DOD/UFGS/UFGS 07 61 14.00 20.pdf>

D07.9.2. Membrane Single-ply

Applicable N/A

Number of base standards 1

Image Tool 250 x 188



Type: **Style 1**

Applies to: Group 1 Group 2 Group 3 Group 4 Other

Mfr: Carlisle Systems

Color: Off-white

Finish: Smooth

Model #: TPO single-ply, "flat" minimal slope

Other: N/A

UFGS: Section 07 53 23 Ethylene-Propylene-Diene-Monomer Roofing
<http://www.wbdg.org/FFC/DOD/UFGS/UFGS 07 53 23.pdf>
Section 07 54 50 TPO Thermoplastic Single-Ply Roofing
(Not Available on UFGS)

D07.9.3. Built-up Multi-ply

Applicable N/A

D07.9.4. Concrete Tile

Applicable N/A

Number of base standards 1

Image Tool 250 x 188



Type: **Style 1**

Applies to: Group 1 Group 2 Group 3 Group 4 Other

Mfr: Regional, TBD

Color: "Weathered Gray"

Finish: Smooth teatured

Model #: Flat profile roof tile, ridge and eave rake units

Other: N/A

UFGS: Section 07 32 16 Concrete Roof Tile
(Not Available on UFGS)

D07.9.5. Clay Tile

Applicable N/A

D07.9.6. Slate Shingles

Applicable N/A

D07.9.7. Vegetated System

Applicable N/A

D07.9.8. Ribbed Metal Sheeting

Applicable N/A

D07.9.9. Composite Shingles

Applicable N/A

Number of base standards 1

Image Tool 250 x 188



Type: **Style 1**

Applies to: Group 1 Group 2 Group 3 Group 4 Other

Mfr: ICI Devoe Pastel Tint Base #BLK 1P32 YOX 1P39 OXR 19

Color: "Weathered Cedar"

Finish: Factory

Model #: Timberline

Other: Gabled or hipped with transverse gable or hipped features

UFGS: Section 07 31 13 Glass-fiber-reinforced Asphalt Shingles
<http://www.wbdg.org/FFC/DOD/UFGS/UFGS 07 31 13.pdf>

D07.9.10. Other

Applicable N/A

D08. STRUCTURAL SYSTEMS

Comply with AF Corporate Standards for Facilities Exteriors:

<http://afcf.wbdg.org/facilities-exteriors/index.html>

Comply with AF Corporate Standards for Structural Systems:

<http://afcf.wbdg.org/facilities-exteriors/structural-systems/index.html>

Comply with AFCFS Recommended Materials:

<http://afcf.wbdg.org/facilities-exteriors/structural-systems/materials/index.html>

Insert 3 photos for each facility group.

Image Tool 250 x 188

Group 1



Group 2



Group 3



Group 4



D08.1. Systems and Layouts

D08.2. Structural Systems Materials

Note: Apply the below base-wide standards for Structural Systems (products, materials and color). Then refer to the Appendix and apply any additional requirements specifically related to the Facility District in which the project is located.

D08.2.1. Concrete

Applicable N/A

D08.2.2. Insulated Concrete Forming (ICF)

Applicable N/A

D08.2.3. Steel

Applicable N/A

Number of base standards 1

Image Tool 250 x 188



Type: **Rigid Framing**

Applies to: Group 1 Group 2 Group 3 Group 4 Other

Mfr: US Steel

Color: Shop primed

Finish: Matte

Model #: Structural steel shapes

Other: N/A

UFGS: Section 05 12 00 Structural Steel

<http://www.wbdg.org/FFC/DOD/UFGS/UFGS 05 12 00.pdf>

D08.2.4. Pre-Engineered Steel

Applicable N/A

Number of base standards 1

Image Tool 250 x 188



Type: **Moment Frame**

Applies to: Group 1 Group 2 Group 3 Group 4 Other

Mfr: Local TBD

Color: Factory primed

Finish: Matte

Model #: Moment Frame

Other: Draped insulation may be used behind wall systems. Deflection criteria must follow IBC.

UFGS: Section 13 12 00 Steel Building Systems
(Not Available on UFGS)

Section 13 34 19 Metal Building Systems

[http://www.wbdg.org/FFC/DOD/UFGS/UFGS 13 34 19.pdf](http://www.wbdg.org/FFC/DOD/UFGS/UFGS%2013%2034%2019.pdf)

D08.2.5. Masonry

Applicable N/A

D08.2.6. Heavy Timber

Applicable N/A

D08.2.7. Light-gauge Steel

Applicable N/A

Number of base standards 1

Image Tool 250 x 188



Type: **Rigid Framing**

Applies to: Group 1 Group 2 Group 3 Group 4 Other

Mfr: Local

Color: Factory

Finish: Galvanized

Model #: Standard Structural Shapes

Other: N/A

UFGS: Section 05 45 00 Light Gauge Steel Framing System
(Not Available on UFGS)

D08.2.8. Lumber Framing

Applicable N/A

D08.2.9. Other

Applicable N/A

D09. MECHANICAL, ELECTRICAL AND PLUMBING

Comply with AF Corporate Standards for Facilities Exteriors:

<http://afcf.wbdg.org/facilities-exterior/index.html>

Comply with AF Corporate Standards for Mechanical, Electrical and Plumbing:

<http://afcf.wbdg.org/facilities-exterior/mechanical-electrical-and-plumbing/index.html>

Insert 3 photos for each facility group.

Image Tool 250 x 188

Group 1



Group 2



Group 3

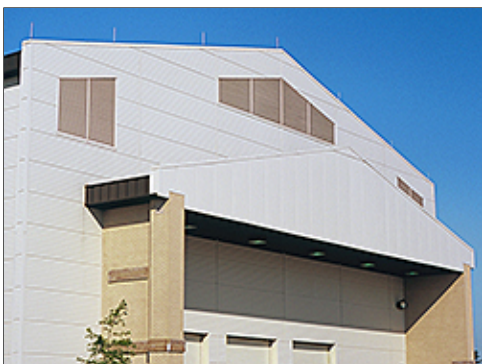

Group 4



D09.1. Passive and Active Systems

GENERAL MEP AF GUIDELINES

1. Fully integrate passive heating and cooling systems into facility designs whenever practical for the local climate prior to the design of active mechanical systems.
2. Provide optimized passive and active systems; design active mechanical systems to supplement thermal mass walls and floors.
3. Develop renewable energy systems when life cycle cost effective.
4. Performance display screens, which report energy performance and utility savings, are encouraged; when provided locate these in building lobbies or common areas.
5. Solar domestic hot water systems are required when life cycle cost effective for the climate.
6. Integrate shading into building exteriors to reduce solar heat gain during hot seasons.

MECHANICAL

1. The Delaware Department of Natural Resources will not allow geothermal well drilling due to underground water contamination.
2. Do not use cooling towers.
3. Provide chillers and condensing units with manufacturer's optional condenser coil fin guards.
4. Dielectric nipples will be used. The use of dielectric unions will not be permitted unless expressly approved by Dover AFB.
5. If chillers are specified, provide valve and cap with 3" camlock connections near chillers for connection of temporary chillers.
6. If heating hot water boilers are specified, provide valve and cap with 3" camlock connections on the exterior of the facility for connection of temporary boilers.
7. Temperature and pressure gauges will be provided on chiller supply and return piping in addition to temperature and pressure sensors required by the controls system.
8. All HVAC direct digital controls will be compatible with the Trane enterprise software used by the Base Civil Engineer Energy Monitoring Control System (EMCS) Shop.
9. All pad-mounted (ground-mounted) equipment all be painted Eagle Feather Tan.

ELECTRICAL

-----Fire Detection/Alarm and Mass Notification Systems (FA/MNS)-----

1 The FA/MNS must be configured in accordance with NFPA 72, UFC 4-021-01 and UFC 3-600-01 for addressable systems. This system will be designed through the construction contract in accordance with the performance based criteria of UFGS specification Section 28 31 76. The contract drawings will indicate the location of the panels, batteries, local operating consoles, annunciators and other head end equipment, but are not required to show all devices. Fire alarm and mass notification panels will be installed in Electrical Rooms, not in Communication Rooms. The specifications will require a stamped and sealed design by a professional fire protection engineer or NICET Level IV technician. UFC 4-021-01 must be added to the industry standards to insure the proper design of the MNS.

1.1 The equipment furnished will be compatible and be UL listed, FM approved, or approved by a nationally recognized testing laboratory in accordance with the applicable NFPA standards.

1.2 The FA control panel will be an addressable panel manufactured by Monaco Enterprises, fully compatible with Dover AFB Proprietary Supervising Station, Monaco model # D-21M operating at 138.925 MHZ. Panels manufactured by other companies are not acceptable.

1.3 All FA/MNS circuits will be supervised. Four-wire FA/MNS circuits are required, and must be specified as listed in the current edition of NFPA 72. Wire size and type will be as recommended by the manufacturer. A looped conduit system must be provided in accordance with NFPA 72.

1.4 All devices will be reported individually as "points". Like devices in a single room may also be grouped into a Zone Position Numbers (ZPN) pending approval during government review of submittals. Point information will be reported to the Monaco Central Receiving System, and the fire alarm control panel will report exclusively to the D-21. All equipment will be uniquely identified on the shop drawings and labeled with the same identifier in the field.

1.5 Electrical rooms, mechanical rooms, and latrines will be provided with visual FA/MNS devices and audible MNS device.

1.6 The ambient sound levels used for determination of performance, location, and mounting of audible signaling devices will not be less than the levels indicated in NFPA 72 (2013 Edition) Table A.18.4.3 entitled Average Ambient Sound Level According to Location. Measurement of actual ambient sound levels in the facility is required and will be coordinated with Civil Engineering prior to taking measurements. Ambient measurements that exceed the values in Table A.18.4.3 will take precedence.

1.7 Enclosures and devices in finished areas will be factory finished white or in a color to coordinate with the surrounding wall finish unless required by codes or standards to be a specific color.

2 In general, buildings with full fire suppression systems will be provided with one fire alarm pull station at the main entrance only. Other than the smoke detector at the fire alarm panel as required by NFPA 72, no other initiating devices will be provided unless dictated by the type of facility. Where required by code and in compliance with A-Gram 08-03 (see attached Appendix B) some facilities require additional Initiating Devices depending on the IBC use identification.

3 All necessary documentation, configuration information, configuration tools, programs, drivers, and other software will be licensed to and otherwise remain with the Government such that the Government or their agents are able to perform repair, replacement, upgrades, and expansions of the system without subsequent or future dependence on the Contractor.

4 The Contract documents must contain sufficient documentation and data, including rights to documentation and data, such that the Government or their agents can execute work to perform repair, replacement, upgrades, deletions, and expansions of the system without subsequent or future dependence on the Contractor.

5 Hardware will be installed and configured such that the Government or their agents are able to perform repair, replacement, modifications, and upgrades of individual hardware without further interaction with the Contractor or manufacturer.

6 The fire alarm control system will provide supervised addressable relays for HVAC shutdown. All AHU in a facility will be programmed to shut down upon activation of a single alarm. An override at the HVAC panel will not be provided. Duct detectors will receive their power and reset from the Fire Alarm Control Unit.

7 The control panel and any field panels will be software reprogrammable to enable expansion or modification of the system without replacement of hardware or firmware. Examples of required changes: adding or deleting devices or zones; changing system responses to particular input signals; programming certain input signals to activate auxiliary devices.

8 Remote System Audible/Visual Graphic Display Annunciator Audible appliance, consider utilization of text display where required. Each project will be evaluated for the requirement for a Remote System Audible/Visual Graphic Display Annunciator Audible Appliance, based on Air Force and industry standards and Dover AFB mission requirements. Consider utilization of text display where an annunciator is required.

9 Technical data and computer software (meaning technical data which relates to computer software) which is specifically identified in this project, and which may be defined/required in other specifications, will be delivered, strictly in accordance with the contract clauses, and in accordance with the Contract Data Requirements List, DD form 1423. Data delivered will be identified by reference to the particular specification paragraph against which it is furnished. Data to be submitted will include complete system, equipment, and software descriptions. Description will show how the equipment will operate as a system to meet performance requirements of this contract. The data package will also include the following:

9.1 Identification of programmable portions of system equipment and capabilities.

9.2 Description of system revision and expansion capabilities and methods of implementation detailing both equipment and software requirements.

9.3 Provision of operational software data on all modes of programmable portions of the fire alarm and detection system.

9.4 Description of Fire Alarm Control Panel equipment operation.

9.5 Description of auxiliary and remote equipment operations.

9.6 Library of application software.

9.7 Operation and maintenance manuals as specified.

10 Software (to include any passwords required for access), connecting cables and proprietary equipment, necessary for the maintenance, testing, modification, and reprogramming of the equipment will be furnished to the Contracting Officer.

11 Radio Alarm Transceivers will be compatible with existing proprietary supervising station receiving equipment. Each radio alarm transceiver will be the manufacturer recognized commercial product, completely assembled, wired, factory tested, and delivered ready for installation and operation. Transceivers will be provided in accordance with applicable portions of NFPA 72, NFPA 1221, and 47 CFR 15. Transceiver electronics module will be contained within the physical housing as an integral, removable assembly.

12 Training course will be conducted for the operations and maintenance staff. The contractor will provide a training plan for approval. In addition to operation and maintenance training, training will be provided on performance of expansions or modifications to the FA/MNS. The training period will start after system is certified.

13 Mass Notification Systems must be installed in new construction and major renovations and will be the standard system provided by Monaco Enterprises to work in concert with the FA system. Systems must comply with UFC 4-021-01. Provide common transceiver (Monaco BTX-M) and same antenna on fire alarm system to support MNS.

13.1 Mass Notification System Prerecorded Messages will be as follows:

1. Attention all personnel, a lockdown has been directed for this facility due to an intruder. All personnel immediately implement lockdown procedures.

2. Attention all personnel, an emergency has been declared requiring this facility to Shelter in Place. All personnel report to the Shelter in Place location and implement procedures.

3. A weather warning has been issued for this area. Please stay tuned for further updates.

4. An emergency has been declared in this facility. Please immediately evacuate to the facility rally point and await further instructions.

5. There has been a change in the FPCON condition. Please check with your building manager for specifics.

6. A fire has been reported in the building. Please evacuate immediately using the closest exit.

***Note to Designer. If building is equipped with an elevator(s) substitute the above with the following message:**

6. A fire has been reported in the building. Please evacuate immediately using the closest exit. Do not use the elevators.

7. All clear, the emergency has been terminated, all clear.

8. This is a test of the Mass Notification System. If there had been an actual emergency you would receive actions to take. This is only a test

14 All initiating and signaling devices will be labeled with a unique identifier.

15 Hangar Fire Protection Systems. All aircraft hangar fire protection system design submittals, including fire protection system shop drawing submittals for construction, must be reviewed and approved by Headquarters Air Force Civil Engineer Center (AFCEC) in accordance with HQ AFCEC/CO Memo dated December 15, 2014.

1 Provide complete design analysis and other documentation required by UFC 3-501-01 and other appropriate UFC's. Short circuit analysis, power device time-current coordination studies, and arc flash analysis will be performed utilizing the most current version of EasyPower. Final electronic files of all studies will be provided with close-out submittals.

2 Electrical manholes will not be used. Pad-mounted electrical switchgear or elbow cabinets are preferred. Should manholes be approved by DAFB in isolated circumstances, they must be no deeper than 4'.

3 There will be no overhead electrical distribution systems. All site utilities are to be built underground with spare conduit, i.e. electrical, comm., cable TV, camera, area lighting.

4 If cathodic protection is required, it will be tested and documented IAW UFC 3-570-02 & NACE standard RP0169, Corrosion Control of External Corrosion on Underground, or Submerged Metallic Piping Systems.

5 All work will be performed by licensed journeyman electricians, or by registered apprentices working under the direct supervision of a licensed journeyman electrician.

6 Electrical Distribution and Service

6.1 The electrical distribution system on Dover Air Force Base (DAFB) is a 12,470/7,200 volt grounded wye system. Where new connections are made to the existing aerial system, the medium voltage feeder to the distribution transformer will be protected by fused loadbreak cutouts. Where new connections are made to the existing underground electrical distribution system, provide new loadbreak elbows and all appurtenances necessary in the associated sectionalizer or padmount switch. Distribution transformers will be pad-mount, wye-wye configuration, with cable parking bushings to isolate cables. Loop-feed transformers equipped with surge arrestors are required. Provide insulated caps for all spare bushings and parking bushings.

6.1.1 Provide all electrical calculations required by UFC 3-501-01. Electronic analyses will be performed with EasyPower software, and all files must be provided. For Design/Build projects, the UFC is clear that the designer of record is responsible for all aspects of the electrical design analysis. For Design/Bid/Build projects, it is understood that the construction contractor will be required to reaccomplish portions of the analysis based on the actual proposed electrical equipment in accordance with UFGS specification requirements.

6.1.2 Primary service to transformers will be via single medium voltage copper conductors, URD type, #2 AWG minimum, with full size concentric neutral (1/3 neutral for three phase applications), 133 % insulation level, XLP-TR insulation in concrete encased 4" diameter minimum Schedule 80 PVC conduits, with the exception that primary services located under roadways which may be directional bored as permitted by the UFC. As a minimum, one spare conduit will be installed at the time of construction.

6.1.3 Secondary services to buildings will be via separate insulated copper conductors installed in Schedule 80 PVC 4" minimum conduits, with at least one spare conduit installed at the time of construction.

6.1.4 New sectionalizers (elbow cabinets) will be installed on all new projects. Existing sectionalizers will not be reused.

6.1.5 New transformers to replace existing will be provided on projects where load requires an increase in transformer capacity, or problems with existing transformer have been identified. Transformers larger than 30 KVA will be floor mounted.

6.1.6 Provision of power for construction and for contractor facilities is the responsibility of the contractor, and will be addressed in the design of each project. Construction documents must show the route of electrical service needed, and the point of connection to the base electrical system. Aerial services are prohibited.

6.2 Building distribution systems will consist of single insulated copper conductors in conduit for all circuits above 30 ampere, all feeders, and all exposed raceway applications. Metal clad (MC) cable is permitted for recessed branch circuits rated 30 ampere or less.

6.2.1 Panelboards will not be exposed in normally occupied spaces or corridors. Dedicated concealed (i.e., closet or room) electrical space within the building interior will be provided. Surface-mounted panelboards are preferable for future expansion purposes. Panel boards will have circuit breakers equipped for overcurrent and fault current protection.

6.2.2 A separate insulated grounding conductor and neutral grounded conductor will be provided in all circuits. Neutral conductors will not serve more than one circuit.

6.2.3 Circuit designations will include all pole numbers from respective panels. It is critical that circuits are fully and succinctly described on the panel legend, and that the contract drawings are consistent throughout with room labels and room numbers so electrical circuits are easily traced.

6.2.4 Provide dedicated branch circuits to HVAC control panels, in order to prevent unnecessary outages in case of problems with other equipment.

6.2.5 Equipment labeling must be carefully developed. Designations will include equipment function, location if possible (for example, floor level, wing designation, etc.), hierarchy of the distribution system, source of power, and other identifying information developed during design.

6.3 Receptacles will be provided at a minimum on all four walls of offices, conference rooms, classrooms, administrative areas, and similar spaces, generally at a spacing of 6' to 8' apart.

6.4 Planned location for furniture systems require placement of circuits in junction boxes above the suspended ceiling or adjacent wall space depending on feed type for systems furniture. Boxes will be mounted one foot above the ceiling and clear of obstructions to permit easy access.

6.5 Electrical rooms will not be accessible from the interior of the building. New facilities will have electrical rooms with only one dedicated exterior entrance door. Exterior doors must be wide enough to move all equipment in or out.

6.6 A framed copy of the single line diagram covered with glass or plastic will be mounted on a wall in the electrical room for all projects that include installation of new panelboards and/or demolition or replacement of existing panelboards. The diagram will show the electrical service entrance and all panelboards in the entire electrical system. Individual branch circuits are not required to be shown. The diagram will have minimum 1/8" text size.

7 Emergency generators and automatic transfer switches are required to be selected competitively. There is no sole source justification or approval for any brand name or vendor.

8 Lightning Protection Systems (LPS), if required, must be configured in accordance with Air Force Instruction 32-1065, "Grounding Systems" and NFPA 780. The designer must provide a completed risk analysis including NFPA, Air Force, and industry standards to substantiate the need for an LPS, which will be evaluated by Dover AFB who will make the final determination. All baseline information required for maintenance and records of the system will be submitted to the government as a prerequisite to final inspection of the system, including plan view of as-built condition showing all pertinent details, (i.e. air terminal connections, down conductor, ground ring connections, etc.), identification of materials and sizes used, and depth of buried materials.

9 Lighting Systems: Provide new interior and exterior lighting in accordance with UFC 3-530-01 *Interior and Exterior Lighting and Controls*, the IES Lighting Handbook, associated ETL's, and other guidance as necessary. Substantiating calculations will be provided.

9.1 All interior and exterior lighting designs will consider LED lighting systems. Life Cycle Cost Analysis must be performed and provided to the government to rule out LED systems before submission of other lighting designs.

9.2 Light fixtures will be placed symmetrically within spaces unless otherwise approved by the Government.

9.2 Fluorescent lighting applications: Provide energy saving F32T8 25 wall lamps and programmed start ballasts.

9.3 Generally design for the prescribed light levels using realistic maintenance factors based on products actually used. Luminaires may not be cleaned at all during their life, so use realistic dirt depreciation factors. Luminaires will be selected to minimize dirt accumulation.

9.4 Emergency lighting will be provided in accordance with prevailing codes, as well as in latrines, mechanical/electrical/communications rooms, and where exposed moving equipment could present a hazard. Emergency and exit lighting will be provided with self-diagnostic capability. Emergency and exit fixtures will be LED.

9.5 Lighting controls will be line voltage unless otherwise approved by the government. Daylighting controls will be incorporated IAW UFC requirements. Exterior lighting will be controlled via a single photocell per building.

10 All underground grounding connections will be made via exothermic welds.

11. Pad mounted electrical transformers, switch gear cabinets, elbow cabinets, etc., will be factory painted Eagle Feather Tan.

Communications

1 Deviation from this guide requires Communications Squadron (CS) approval.

2 Buildings will be pre-wired complete with Category 6 cable and RJ 45 jacks. The communications cable will be unshielded twisted pair, four pair (eight conductors), 24 gauge, ASTM B-3 annealed copper wire with semi-rigid polyvinyl chloride insulation. Outer jacket will be constructed of flexible polyvinylchloride. Cable will meet REA PE-20 requirements and will be Category 6 compliant. Required conductor colors are listed at the end of this section.

2.1 Cable will be installed in a complete conduit and/or cable tray system. Open cable supported by hooks or rings is not acceptable. Category 6 Data cables will be no longer than 90 meters from Data jack to Communications room.

2.2 In facilities with multiple communications rooms, provide cable tray between the rooms for future use by the government to install riser cable. If cable tray cannot be provided due to space constraints, provide 4" PVC conduit.

3 Communication System Drawings must be submitted for CS and BCE approval. The drawing submittal will include a complete list of equipment and material, including manufacturer's descriptive and technical literature, catalog cuts, and installation instructions. System drawings showing final configuration, including location, cable path, type, gauge, and number assignment of inside wiring, wall jack labeling and floor plan layout for the equipment after installation will be provided.

3.1 For single occupancy offices, one duplex outlet will be provided on each wall next to a power receptacle. For multiple occupancy offices and administrative areas, one triplex outlet will be provided next to each power receptacle. Additional outlets will be provided as equipment and user needs dictate.

3.2 Modular work stations will be provided with one quad outlet. Additional outlets will be provided as equipment and user needs dictate.

4 Communication Outlets: Communications outlets will be flush mounted in a non-metallic nominal 4" by 4" wall box. Each jack will be provided with 110-type terminals and will comply with requirements for EIA/TIA T568B, 4 pair, category 6. Modular telephone outlets will comply with FCC Rules and Regulations, Part 68, Subpart F.

4.1 Duplex outlet arrangement will be top jack for voice transmission and the bottom jack for data transmission.

4.2 Quad outlet arrangement will be top left jack for voice and remaining three for data transmission.

4.3 Triplex outlet arrangement will be top jack for voice and remaining two for data transmission.

4.4 Single Outlet arrangement will be one jack for voice transmission mounted 57" above the finished floor level. This is used for wall mounted phone locations.

5 Device Plates: Device plates will have ivory finish. Device plates for wall phones will have mounting posts to accommodate standard wall phones.

6 Communications Terminal Backboards: Telephone backboard locations will be shown on the drawings. The backboards will be 4 foot by 8 foot, 3/4-inch plywood either fire rated or provided with a two-coat insulating fire retardant finish.

7 Contractor will provide all material and labor to terminate and test communications cabling.

7.1 Voice jacks will be terminated on the plywood back board using BIX blocks and BIX termination.

7.2 Data jacks will be terminated at CAT 6 Patch Panels mounted in 6' high racks. Terminations will meet EIA/TIA 568B. In dedicated communication rooms, provide floor mounted open racks, properly grounded. If racks must be provided in shared spaces, they will be installed in lockable enclosures, either floor or wall mounted.

7.3 Test Reports will be provided for each communications jack/outlet and cable, through the standard submittal process. Upon receipt from the contractor, the government will provide a copy of the test results to the Communications Squadron. Cables will be tested to confirm compliance with unshielded twisted-pair (UTP) Category 6 cabling per ANSI/TIA 568-C.2.

8 Labeling: All Voice and data jacks will be labeled on the device plate as well as the patch panel/ BIX block. Labels should be an easily readable font at ¼ inch in height. The jack labels will designate voice or data with a “V” or “D” respectively, include the room number, and a jack number. This label will then have a corresponding label at the patch panel and BIX block. Example label would be: V 5-1 / D 5-1, for the first plate in room 5 of a building. For rooms that are not designated by number like mechanical rooms a letter corresponding with that room should be used instead, i.e. V M-1 / D M-1.

9 Spare wires will be wrapped around the insulated sheath on the wire in the outlet box. The wiring will be connected at the outlets as follows:

Jack	Terminal	Pin #	Wire (Main Color - Marker)
All Jacks	Green	5	White - Blue
	Red	4	Blue - White
	Blue	1	White - Orange
	Orange	2	Orange - White
	Black	3	White - Green
	Yellow	6	Green - White
	Brown	7	White - Brown
	White	8	Brown - White

10 Incorporate ETL 02-12 Communication and Information System Criteria for AF facilities. All MILCON projects will include all common-user telephone and local area networks (LAN), both Non-secure Internet Protocol Router Network [NIPRNET] and Secure Internet Protocol Router Network [SIPRNET], infrastructure requirements to accommodate connecting operational and administrative end-user equipment.

10.1 This includes, but is not limited to, the following:

11.10.1.1 Customer jacks (telephone, fax, LAN, pay phone, community access [cable] television [CATV]), All wiring, cabling, fiber optic cables (FOC), conduits, ducts, manholes, and pathways from the customer's jacks to the point where the new facility will receive network services (dial tone and Internet protocol access), Connectivity for facility energy monitoring and control systems (EMCS) and fire alarm systems, Entry control, intrusion detection, antiterrorism/force protection, and alarm system wiring infrastructure and components such as card readers and magnetic locks (monitors, cameras, and scanners are excluded), Termination devices (cross-connects, patch panels, distribution frames, network protectors), Communications equipment rooms (CER), closets, and other pathways, Provisions only (e.g., floor space, electrical/mechanical utilities, ducts, and other real property improvements and fixtures) for special-purpose equipment, such as secure switches, radio transmitters, and audio-visual equipment, Access floor systems, Communications and information infrastructure requirements other than equipment when validated in advance and supported by the major command (MAJCOM) for inclusion into the military construction program (MCP) project's programming documentation, Permanently installed standby power (real property installed equipment [RPIE]) generators when justified, Associated MILCON planning and design

10.2 The following items will not be funded with MILCON appropriations and will continue to be funded from appropriate 3400 (Operation & Maintenance, Air Force) or 3080 (Air Force Procurement [Equipment]) funds:

10.2.1 End instruments (telephones, secure telephone units [STU], secure terminal equipment [STE], computers, printers, video projectors, scanners, fax machines, copiers) and installation, terminations of building wiring infrastructure at equipment or onto existing, base networks, special-purpose equipment (e.g., secure switches, radio transmitters, and audio-visual equipment) and installation, prewired work stations or furniture systems and installation, switching equipment (telephone switches, additional telephone central office line cards, and LAN switches) and installation, optical carrier equipment and installation, CATV amplifiers and splitters which will be government-owned, network servers, routers, and hubs and installation, encryption equipment for classified systems and installation, power conditioning equipment such as uninterruptible power supplies (UPS), and installation, associated system engineering for items identified in this paragraph.

11 Suspended Ceiling: Where future systems furniture is planned, provide wiring in junction boxes or cable trays above the suspended ceiling in the area. Boxes/trays will be mounted one foot above the ceiling and clear of obstructions to permit easy access.

12 Provide a #2/0 bare copper grounding conductor from the facility/building service entrance ground to each communications room. Connect the grounding conductor to a 12" long by 4" wide by 3/8" thick copper ground bus (as a minimum or larger as may be determined on a project by project basis) mounted below the telephone termination board. Final grounding test results will be provided to the Government.

13 All work must be performed by licensed journeyman electricians, or by registered apprentices working under the direct supervision of a licensed journeyman electrician.

14 Communications Rooms: Architectural, environmental, and electrical power requirements are contained within UFC 3-580-01. Provide dedicated communications rooms for new facilities, and for renovated facilities to the maximum extent possible.

14.1 Rooms will have only one dedicated door which will be to the building exterior. The door will be keyed the same as mechanical and electrical rooms.

14.2 Provide detailed drawings of communications rooms showing the locations of all equipment including termination equipment racks, terminal backboards, grounding bus, cable trays, mechanical equipment, etc.

15 The project design will require the construction contractor to provide communication conduit(s) from the facility communications room to a termination point at the project perimeter. In general, conduits will be installed underground from the communications room through the floor and transitioned horizontally via long sweep elbows. Conduit(s) will be 4" SCH 40 PVC in a sufficient number as determined by the design based on facility requirements through coordination with the Communications Squadron during the design process. The DAFB communications contractor will be responsible for constructing all communication infrastructure from the Base distribution system to the contractor's termination point and installing all communications lines from the Base distribution system to the facility communication room and termination on the communications rack. For MILCON projects, the portion of work executed by Dover AFB's communication contractor will be funded with project funds and MIPR'd to Tinker AFB prior to execution.

PLUMBING

1. Hose Bibs. Locate a hose bib in each mechanical room, mechanical yard and at each condenser. All exterior hose bibs will be frost-proof with integral backflow preventers.

2. Flushometer Valve: Standard model is the Sloan Royal Flushometer Valve. <http://www.sloanplumbingparts.com/repair-parts/flushometer/manual#isAjax=1&price=,100>

3. Fire Department Connections on exterior of new facilities will be a 5 inch Stortz mounted 24" to 36" above grade. Do not use a Wye Connection.

D09.2. Functionality and Efficiency

1. Fully coordinate mechanical, electrical, plumbing (MEP) and fire protection systems with each other and with the building structure, enclosure, thermal envelope and interior design.

2. Ensure direct exterior access is provided (for CE) to main mechanical and electrical rooms.

3. Screen exterior equipment from primary views (landscape, building masses, screen walls) and comply with AT requirements.

4. Keep equipment away from main building entrances; locate service area/yard on least visible side of a building.

5. Coordinate the location of all exterior meters, equipment and devices to provide convenient access and an overall coordinated and orderly appearance.

6. Design emergency generator systems integrally with all other building systems and avoid incompatible building additions; locate generators near service areas and ensure they are not visible from primary entrances.

7. When structure is exposed as a finished ceiling, fully integrate MEP and fire protection systems to provide an organized uncluttered appearance.
8. Conceal ducts, piping, conduits, devices, etc., when permanent walls, suspended ceilings or raised floors are provided; locate sprinkler heads in orderly configuration.
9. Limit interior wall-mounted equipment in occupied personnel spaces; avoid surface-mounted conduit and pipes.
10. Provide efficient utility rooms with layouts to facilitate system performance and maintenance; provide convenient access to controls, clearly label systems and include operating and maintenance instructions.
11. Separate mechanical and electrical and communications rooms.
12. Integrate recessed and wall-mounted fixtures such as fire standpipe cabinets and drinking fountains within permanent walls.

E. FACILITIES INTERIORS

Comply with Air Force Corporate Standards for Facilities Interiors:
<http://afcfb.wbdg.org/facilities-interiors/index.html>

Insert 3 photos for each facility group.

Image Tool 250 x 188

Group 1

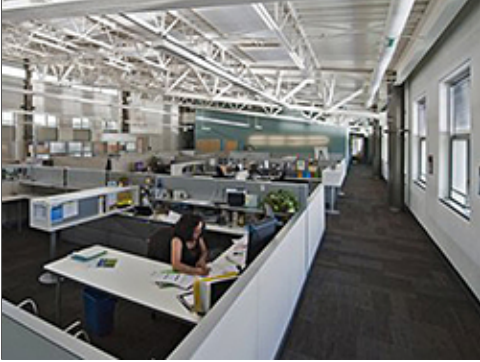

Group 2

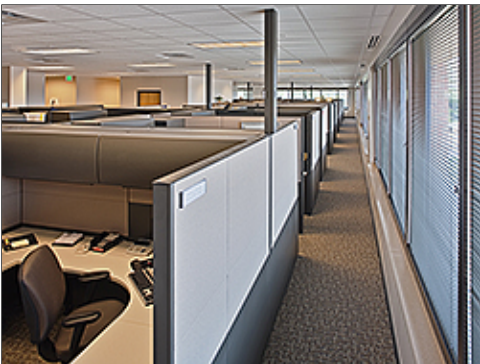

Group 3



Group 4



E01. Building Configurations

Comply with Air Force Corporate Standards for Building Configurations:

<http://afcfs.wbdg.org/facilities-interiors/buildings-configurations/index.html>

1. Provide open-plan configurations for office, administrative, operational and related activities and spaces for maximum flexibility. Use a “core and shell” approach in which all building systems, infrastructure and permanent interior partitions anticipate two or more uses (operations) during a facility’s lifespan.
2. Create flexible interior configurations using Furniture, Fixtures & Equipment (FF&E) and limit private offices and private rooms. Refer to AFMAN 32-1084 for space requirements. To the greatest extent, limit permanent partitions to core areas such as toilet rooms, stairs, mechanical and utility rooms.
3. Use more durable long-lasting finishes in core areas for walls, ceilings, floor coverings and built-in casework. Coordinate interior FF&E layouts with structural grids during space planning.
4. Provide high-performance building configurations following UFC 1-200-02. Ensure passive design strategies are cost effectively incorporated before active mechanical systems are designed.
5. Comply with UFC 1-200-01, general building requirements. UFC 1-200-01 provides applicability of model building codes and government unique criteria for typical design disciplines and building systems, as well as for accessibility, antiterrorism, security, high performance and sustainability requirements, and safety.
6. Meet security and force protection requirements in UFC 4-010-01: DoD Minimum Antiterrorism Standards for Buildings.
7. Comply with AFCFS for supporting mission requirements, addressing human comfort and well being, and creating highly flexible interiors while satisfying metrics for high performance and sustainable buildings.
8. Provide a level of quality for interior features, materials and finishes that is appropriate for the Facility Group number. Group 1 may receive higher quality than Groups 2 thru 4. Refer to Facility Hierarchy.
9. Through open-plan configurations, preserve all passive and natural design strategies and fully integrate facility interiors with overall building systems.
10. Professional interior designers, or architects with significant interior design experience, must accomplish the design and review of applicable new construction, renovations and maintenance projects.
11. Consult with the State Historic Preservation Officer (SHPO) and base-level Historic Preservation offices regarding proposed changes to properties listed on or eligible for listing on the National Register of Historic Places. Follow requirements of The National Historic Preservation Act and Secretary of the Interior Standards for the Treatment of Historic Properties.
12. Maintain architectural compatibility following AFCFS and this Installation Facilities Standards (IFS) document to create continuity while avoiding monotony.

E01.1. Layout and Common Areas

Comply with Air Force Corporate Standards for Layout and Common Areas:

<http://afcfs.wbdg.org/facilities-interiors/buildings-configurations/layout-and-common-areas/index.html>

1. Create open-plan interior environments to accommodate changes.
2. Limit interior partitions, private offices and rooms; use furniture or modular systems to provide privacy and acoustic control.
3. When partitions are functionally justified such as for conference rooms, use systems furniture and moveable (demountable) floor-to-ceiling wall systems for acoustical or visual privacy.
4. Proportion lobbies and common spaces based on type of function, activity and facility group.
5. Allow no direct sight lines into restrooms.
6. Situate utility and core areas to minimize impact on daylighting and to maximize use as thermal buffers.

7. Ensure electrical, lighting and communications system can be adaptable to configuration changes.
8. Avoid power poles to the maximum extent; when poles are necessary minimize the number and coordinate locations with furniture placement and other elements.
9. Avoid sloping floors to maintain flexibility and eliminate future structural changes.
10. Special consideration may apply to Sensitive Compartmented Information Facilities (SCIFs).

E01.1.1. Interior Design Process

1. Comply with UFC 3-120-10 for the Comprehensive Interior Design (CID,) which includes both Structural Interior Design (SID) and Furniture, Fixtures & Equipment (FF&E) design services.
2. Use a collaborative, integrated planning and design team, composed of user, government support staff, and appropriate professionals. Integrate architectural features using simple detailing to create a professional appearance; avoid extravagant or excessive detailing.
3. Ensure interior designs satisfy the functional requirements within the context of flexibility, sustainability and the building's energy performance.
4. Base space planning on square foot allocations from AFM 32-1084. Identify special requirements if any, such as privacy separation, VIP areas, gathering spaces and storage. Note: The occupant's rank and position will influence the square footage and selection of materials.
5. Provide clear circulation and pathway finding for both horizontal and vertical directions that accommodate the number of personnel in the facility.
6. Maximize efficiencies in the space plan for functional relationships and adjacencies for all facility users. Efficiently create and situate rooms and support rooms such as conference / meeting rooms and break rooms.
7. Provide interior design building-related illustrations, drawings, schedules, materials selections, specifications and cost estimates as listed in UFC 3-120-10. Refer to Furnishings in this IFS also.
8. SID Format must follow UFC 3-120-10.
9. Base the FF&E package on the furniture footprint developed in the SID. Identify all new or existing equipment needed and its users within each facility or each area of the facility. Provide specific information on: equipment sizes, electrical requirements, ventilation requirements, weight (if heavy), quantity, and security level if required. Presume all administrative spaces have computers and supporting equipment.
10. Locks will be keyed in sets or subsets as scheduled. Locks will be furnished with the manufacturer's standard construction key system. Change keys for locks will be stamped with change number and the inscription "U.S. Property - Do Not Duplicate." Keys will be supplied as follows: Locks: 3 change keys each lock. Master keyed sets: 3 keys each set.
11. Lock Cylinders (Mortise, Rim, and Bored): All locks, keying, and hardware to comply with Builders Hardware Manufacturer's Association (BHMA).

E01.1.2. Codes and Regulations

1. Refer to UFC 1-200-01 for modifications to the International Building Code (IBC) to determine applicable sections of the IBC. Both the IBC Chapter 3 and UFC 3-600-01 govern "Use and Occupancy Classification" for example.
2. Fire code requirements will be as defined in the International Building Code (IBC) and must be used where dictated by UFC 1-200-01 DoD Building Code (General Building Requirements) except where noted in UFC 3-600-01 (Fire Protection Engineering For Facilities).
3. National Fire Protection Association (NFPA) 101 must be utilized to determine the occupancy classification as it relates to fire/ smoke resistance rating of interior non-load bearing partitions (other than occupancy separation), means of egress, interior finish, features of fire protection (including vertical openings) and associated requirements.

E01.2. Quality and Comfort

Comply with Air Force Corporate Standards for Quality and Comfort:

<http://afcfs.wbdg.org/facilities-interiors/buildings-configurations/quality-and-comfort/index.html>

1. Include durability in the life cycle cost analysis for best-value material selections with long life expectancies that do not show excessive wearing.
2. Select long-lasting materials and finishes for permanent core areas such as lobbies, restrooms and stairs.
3. Select low-maintenance materials and products that reduce ongoing servicing and repair and that are easy to clean.
4. Relate the visual quality of finishes to the Facility Group number.
5. Building and interior configurations should address both operations and climatic responses.
6. Convey a professional image; avoid trendy patterns and textures.
7. Use materials and finishes that provide a healthy indoor environment.
8. Orient interior spaces toward views while maintaining cost-effective building performance and efficiency.
9. Promote air movement and daylighting for human health and wellbeing.

E02. Floors

Comply with Air Force Corporate Standards for Floors:

<http://afcfs.wbdg.org/facilities-interiors/floors/index.html>

E02.1. Floor Materials

Facility Group 1 floor materials will be as follows.

Primary: Prepared Slabs, Terrazzo with BCE Approval
Secondary: Porcelain Tile, Prepared Slabs
Tertiary: Carpet, Rubber Stair Treads

Facility Group 2 floor materials will be as follows.

Primary: Carpet, Rubber Stair Treads
Secondary: Ceramic tile
Tertiary: N/A

Facility Group 3 floor materials will be as follows.

Primary: Epoxy-Coated Slabs
Secondary: Prepared Slabs (Sealed)
Tertiary: Carpet, Rubber Stair Treads

Facility Group 4 floor materials will be as follows.

Primary: Carpet
Secondary: Ceramic tile
Tertiary: N/A

1. Natural stone and terrazzo flooring may be used in high traffic areas of Group 1 as approved on a case-by-case basis.
2. Carpet: Refer to Engineering Technical Letter (ETL) 07-4 "Air Force Carpet Standard" for carpet requirements. Specify broadloom carpet goods (not carpet tiles) for all applications except areas containing raised (computer) flooring systems, unless approved by Dover AFB.
3. Resilient and rapidly renewable flooring may be used in low traffic areas in Group 1, 2 and 4.
4. Manufacturers listed below are only provided to establish a baseline of equivalency among all applicable manufacturers.

Note: Apply the below base-wide standards for Floors (products, materials and color). Then refer to the Appendix and apply any additional requirements specifically related to the Facility District in which the project is located.

E02.1.1. Prepared Slabs

Applicable N/A Number of base standards 2

Image Tool 250 x 188



Type: **Style 1, Ground and Polished**

Applies to: Group 1 Group 2 Group 3 Group 4 Other

Mfr: Local (TBD)

Color: Natural gray cement, light to dark beige aggregates

Finish: Fine polished texture

Model #: Medium to small aggregate

Other: N/A

UFGS: Section 03 35 45 Polished Concrete Finishing
(Not Available on UFGS)

Type: **Style 2, Polished**

Applies to: Group 1 Group 2 Group 3 Group 4 Other

Mfr: Local (TBD)

Color: Natural gray cement, light to dark beige aggregates

Finish: Medium polished texture, slip resistant

Model #: Medium to small aggregate

Other: N/A

UFGS: Section 03 35 45 Polished Concrete Finishing
(Not Available on UFGS)



E02.1.2. Natural Stone and Terrazzo

Applicable N/A

E02.1.3. Quarry Tile

Applicable N/A

Number of base standards 1

Image Tool 250 x 188



Type: **Style 1**

Applies to: Group 1 Group 2 Group 3 Group 4 Other

Mfr: Daltille

Color: Earth tones

Finish: Matte, slip resistant

Model #: N/A

Other: Use in commercial kitchen flooring.

UFGS: Section 09 30 10 Ceramic, Quarry, and Glass Tiling
<http://www.wbdg.org/FFC/DOD/UFGS/UFGS 09 30 10.pdf>

E02.1.4. Ceramic Tile

Applicable N/A

Number of base standards 2

Image Tool 250 x 188



Type: **Style 1 Porcelain**

Applies to: Group 1 Group 2 Group 3 Group 4 Other

Mfr: Daltille

Color: Earth tones

Finish: Matte, slip resistant

Model #: Porcelain tile

Other: Use in high traffic areas. Epoxy grout is recommended.

UFGS: Section 09 30 10 Ceramic, Quarry, and Glass Tiling
<http://www.wbdg.org/FFC/DOD/UFGS/UFGS 09 30 10.pdf>



Type: **Style 2 Ceramic**

Applies to: Group 1 Group 2 Group 3 Group 4 Other

Mfr: Daltile

Color: Earth tones

Finish: Matte, slip resistant

Model #: Ceramic tile

Other: Use in low traffic area toilet rooms.

UFGS: Section 09 30 10 Ceramic, Quarry, and Glass Tiling
<http://www.wbdg.org/FFC/DOD/UFGS/UFGS 09 30 10.pdf>

E02.1.5. Resilient Floor

Applicable N/A

Number of base standards 1



Type: **Style 1 Stair Treads**

Applies to: Group 1 Group 2 Group 3 Group 4 Other

Mfr: Roppe

Color: Neutral tones

Finish: Factory

Model #: Raised design rubber tread

Other: Stair treads material

UFGS: Section 09 65 00 Resilient Flooring
<http://www.wbdg.org/FFC/DOD/UFGS/UFGS 09 65 00.pdf>

E02.1.6. Carpet

Applicable N/A

Number of base standards 2

Image Tool 250 x 188



Type: **Style 1**

Applies to: Group 1 Group 2 Group 3 Group 4 Other

Mfr: Mohawk Group

Color: Neutral multi-colored tones/patterned/solid

Finish: Yarn: Nylon 6 or 6.6/cut pile or loop pile

Model #: Broadloom, 6' wide rolled, carpet tiles, entry walk-off carpet

Other: N/A

UFGS: UFGS 09 68 00 Carpeting

<http://www.wbdg.org/FFC/DOD/UFGS/UFGS 09 68 00.pdf>

Type: **Style 2**

Applies to: Group 1 Group 2 Group 3 Group 4 Other

Mfr: Mohawk Group

Color: Earth tones

Finish: Factory

Model #: Broadloom, residential loop, "Smartstrand"

Other: N/A

UFGS: UFGS 09 68 00 Carpeting

<http://www.wbdg.org/FFC/DOD/UFGS/UFGS 09 68 00.pdf>



E02.1.7. Rapidly-Renewable Products

Applicable N/A

E02.1.8. Other

Applicable N/A

E03. Walls

Comply with Air Force Corporate Standards for Walls:
<http://afcfs.wbdg.org/facilities-interiors/walls/index.html>

E03.1. Wall Materials

Facility Group 1 wall materials will be as follows.

Primary: Brick (or other as approved by the BCE)

Secondary: Gypsum board (painted)

Tertiary: Ceramic tile (restrooms)

Facility Group 2 wall materials will be as follows.

Primary: Gypsum board (painted)

Secondary: Brick (or other as approved by the BCE)

Tertiary: Ceramic tile (restrooms)

Not Applicable

Facility Group 3 wall materials will be as follows.

Primary: Ground face block, sealed (do not paint)

Secondary: N/A

Tertiary: Ceramic tile (restrooms)

Facility Group 4 wall materials will be as follows.

Primary: Gypsum board (painted)

Secondary: N/A

Tertiary: Ceramic tile (restrooms)

Note: Apply the below base-wide standards for Walls (products, materials and color). Then refer to the Appendix and apply any additional requirements specifically related to the Facility District in which the project is located.

E03.1.1. Concrete

Applicable N/A

E03.1.2. Masonry

Applicable N/A

Number of base standards 1

Image Tool 250 x 188



Type: **Modular Face Brick**

Applies to: Group 1 Group 2 Group 3 Group 4 Other

Mfr: Local (TBD)

Color: Red blend

Finish: Light texture

Model #: Coursed unit masonry

Other: Brick is preferred. Concrete block may only be used in Group 3 when approved by the BCE.

UGFS: Section 04 20 00 Unit Masonry

<http://www.wbdg.org/FFC/DOD/UGFS/UGFS 04 20 00.pdf>

E03.1.3. Ceramic Tile

Applicable N/A

Number of base standards 1

Image Tool 250 x 188

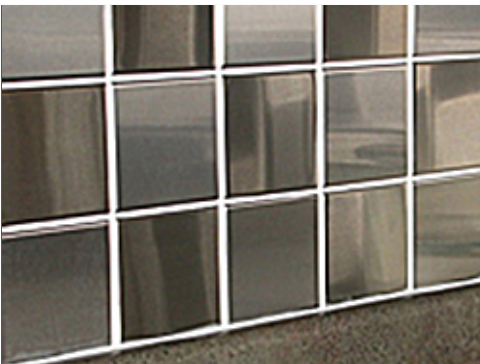

Type: **Style 1**

Applies to: Group 1 Group 2 Group 3 Group 4 Other

Mfr: Daltile

Color: Earth tones

Finish: Gloss, Semi-gloss

Model #: Ceramic wall tile

Other: Located on wet walls in restrooms, minimum 6"X6" tile

UGFS: Section 09 30 10 Ceramic, Quarry, and Glass Tiling

<http://www.wbdg.org/FFC/DOD/UGFS/UGFS 09 30 10.pdf>

E03.1.4. Gypsum Board

Applicable N/A

Number of base standards 1

Image Tool 250 x 188



Type: **Style 1**

Applies to: Group 1 Group 2 Group 3 Group 4 Other

Mfr: US Gypsum

Color: Solid Earth tone colors

Finish: Paint (Sheen per UFGS)

Model #: Tapered edge

Other: N/A

UFGS: Section 09 29 00 Gypsum Board

<http://www.wbdg.org/FFC/DOD/UFGS/UFGS 09 29 00.pdf>

Section 09 90 00 Paints and Coatings

<http://www.wbdg.org/FFC/DOD/UFGS/UFGS 09 90 00.pdf>

E03.1.5. Metal Panels

Applicable N/A

E03.1.6. Wood Paneling

Applicable N/A

E03.1.7. Rapidly-Renewable Products

Applicable N/A

E03.1.8. Other

Applicable N/A

E04. Ceilings

Comply with Air Force Corporate Standards for Ceilings:

<http://afcs.wbdg.org/facilities-interiors/ceilings/index.html>

E04.1. Ceiling Materials

Facility Group 1 ceiling materials will be as follows.

Primary: Exposed Framing (Roof / Floor Structure Above)
Secondary: Grid and Acoustical Tile
Tertiary: Gypsum board (painted)

Facility Group 2 ceiling materials will be as follows.

Primary: Exposed Framing (Roof / Floor Structure Above)
Secondary: Grid and Acoustical Tile
Tertiary: Gypsum board (painted)

Facility Group 3 ceiling materials will be as follows.

Primary: Exposed Framing (Roof / Floor Structure Above)
Secondary: Exposed Framing (Roof / Floor Structure Above)
Tertiary: Gypsum board (painted)

Facility Group 4 ceiling materials will be as follows.

Primary: Gypsum board (painted)
Secondary: N/A
Tertiary: N/A

1. Accent ceiling materials such as metal, wood, and rapidly renewable may be used in Group 1 as approved on a case-by-case basis.

2. Follow UFC 3-450-01 (Vibration and Noise Control) for acoustic design issues including speech privacy, sound isolation or sound masking.

3. Manufacturers listed below are only provided to establish a baseline of equivalency among all applicable manufacturers.

4. Acoustical Ceiling Systems. Administrative / office-type spaces, associated restrooms and breakrooms in Group 1 and 2 requiring sound attenuation will use "Style 1" 2' x 2' recessed white grid system as listed in Section E04.1.3. Utility spaces such as workshops and areas in Group 3 requiring sound attenuation will use "Style 2" lay-in tiles listed in Section E04.1.3.

Note: Apply the below *base-wide standards* for Ceilings (products, materials and color). Then refer to the Appendix and apply any additional requirements specifically related to the Facility District in which the project is located.

E04.1.1. Exposed Framing (Roof / Floor Structure Above)

Applicable N/A

Number of base standards 1

Image Tool 250 x 188



Type: **Style 1**

Applies to: Group 1 Group 2 Group 3 Group 4 Other

Mfr: Vulcraft

Color: Neutral colors reviewed on a case-by-case basis

Finish: Field painted (Sheen per UFGS)

Model #: Formlok floor and roof decking

Other: N/A

UFGS: Section 05 30 00 Steel Decks

<http://www.wbdg.org/FFC/DOD/UFGS/UFGS 05 30 00.pdf>

E04.1.2. Exposed Concrete

Applicable N/A

E04.1.3. Grid and Acoustical Tile

Applicable N/A

Number of base standards 6

Image Tool 250 x 188



Type: **Style 1A - General Offices/ Corridors/ Conference Rooms**

Applies to: Group 1 Group 2 Group 3 Group 4 Other

Mfr: USG

Color: White

Finish: Factory

Model #: 86185, 2'x2', Mars ClimaPlus Performance, SQ edge, grid 15/16"

Other: Performance characteristics are Class A; NRC-0.75; CAC-35; LR-0.90; GREENGUARD Gold Certified, minimum recycled content 68%.

UFGS: Section 09 51 00 Acoustical Ceilings

<http://www.wbdg.org/FFC/DOD/UFGS/UFGS 09 51 00.pdf>

Type: **Style 1B - General Offices/ Corridors/ Conference Rooms**

Applies to: Group 1 Group 2 Group 3 Group 4 Other

Mfr: Armstrong

Color: White

Finish: Factory

Model #: 1445, 2'x2', ULTIMA Health Zone High SQ edge, grid 15/16"

Other: Meet ASTM E1264, Class A, NRC-0.80, CAC-35, LR-.86, Recycled Content >= 50%.

UFGS: Section 09 51 00 Acoustical Ceilings
<http://www.wbdg.org/FFC/DOD/UFGS/UFGS 09 51 00.pdf>



Type: **Style 2A - Laundry Facilities/ High Moisture Areas**

Applies to: Group 1 Group 2 Group 3 Group 4 Other

Mfr: USG

Color: White

Finish: Factory

Model #: 56099, 2'x2', Clean Room Class 100, SQ edge, grid 15/16"

Other: Performance characteristics are Class A; NRC- No rating; CAC-35; LR-0.77; GREENGUARD Gold Certified, min. recycled content >/=55%.

UFGS: Section 09 51 00 Acoustical Ceilings
<http://www.wbdg.org/FFC/DOD/UFGS/UFGS 09 51 00.pdf>





Type: **Style 2B - Laundry Facilities/ High Moisture Areas**

Applies to: Group 1 Group 2 Group 3 Group 4 Other

Mfr: Armstrong

Color: White

Finish: Factory

Model #: 1715, 2'x2', Clean Room VL, SQ edge, grid 15/16"

Other: Performance characteristics are Class A; NRC-0.55; CAC-35; LR-0.79; GREENGUARD Gold Certified, minimum recycled content \geq 50%.

UFGS: Section 09 51 00 Acoustical Ceilings
<http://www.wbdg.org/FFC/DOD/UFGS/UFGS 09 51 00.pdf>

Type: **Style 3A - Dormitories**

Applies to: Group 1 Group 2 Group 3 Group 4 Other

Mfr: USG

Color: White

Finish: Factory

Model #: 707 , 2'x2', Glacier Basic, SQ edge, grid 15/16"

Other: Performance characteristics are Class A; NRC-0.65; CAC-35; LR-0.70; GREENGUARD Gold Certified, minimum recycled content 72%.

UFGS: Section 09 51 00 Acoustical Ceilings
<http://www.wbdg.org/FFC/DOD/UFGS/UFGS 09 51 00.pdf>



Type: **Style 3B - Dormitories**



Applies to: Group 1 Group 2 Group 3 Group 4 Other

Mfr: Armstrong

Color: White

Finish: Factory

Model #: 563 , 2'x2', CIRRUS, SQ edge, grid 15/16"

Other: Performance characteristics are Class A; NRC-0.75; CAC-35; LR-0.85; GREENGUARD Gold Certified, minimum recycled content >=50%.

UFGS: Section 09 51 00 Acoustical Ceilings
<http://www.wbdg.org/FFC/DOD/UFGS/UFGS 09 51 00.pdf>

E04.1.4. Gypsum Board

Applicable N/A Number of base standards 1

Image Tool 250 x 188



Type: **Style 1**

Applies to: Group 1 Group 2 Group 3 Group 4 Other

Mfr: US Gypsum

Color: Solid neutral colors

Finish: Paint (sheen per UFGS)

Model #: Tapered edge

Other: N/A

UFGS: Section 09 29 00 Gypsum Board
<http://www.wbdg.org/FFC/DOD/UFGS/UFGS 09 29 00.pdf>
Section 09 90 00 Paints and Coatings
<http://www.wbdg.org/FFC/DOD/UFGS/UFGS 09 90 00.pdf>

E04.1.5. Metal Panels

Applicable N/A

E04.1.6. Wood

Applicable N/A

E04.1.7. Rapidly-Renewable Products

Applicable N/A

E04.1.8. Other

Applicable N/A

E05. Doors and Windows

Comply with Air Force Corporate Standards for Doors and Windows:

<http://afcf.wbdg.org/facilities-interiors/doors-and-windows/index.html>

E05.1. Doors and Windows and Frames Materials

Facility Group 1

door (frame) and window frame materials will be as follows.

Primary: Aluminum, clear anodized

Secondary: Hollow metal (painted)

Tertiary: N/A

Facility Group 1

door (leaf) materials will be as follows.

Primary: Hardwood veneer

Secondary: Hollow metal (painted)

Tertiary: N/A

Facility Group 2

door (frame) and window frame materials will be as follows.

Primary: Aluminum, clear anodized

Secondary: Hollow metal (painted)

Tertiary: N/A

Facility Group 2

door (leaf) materials will be as follows.

Primary: Hardwood veneer

Secondary: Hollow metal (painted)

Tertiary: N/A

Facility Group 3

door (frame) and window frame materials will be as follows.

Primary: Hollow metal (galvanized, painted)

Secondary: Hollow metal (galvanized, painted)

Tertiary: N/A

Facility Group 3

door (leaf) materials will be as follows.

Primary: Hollow metal (galvanized, painted)

Secondary: Hollow metal (galvanized, painted)

Tertiary: N/A

Facility Group 4

door (frame) and window frame materials will be as follows.

Primary: Wood

Secondary: N/A

Tertiary: N/A

Facility Group 4

door (leaf) materials will be as follows.

Primary: Wood solid core

Secondary: Composite solid core

Tertiary: N/A

1. Hardwood casings may be provided over metal frames in Group 1 as approved on a case-by-case basis.
2. Paneled textured doors are preferred in Group 4.
3. Do not use hollow-core wood doors.
4. Generally match original hardware in renovations.
5. Manufacturers listed below are only provided to establish a baseline of equivalency among all applicable manufacturers.

Note: Apply the below base-wide standards for Doors and Windows (products, materials and color). Then refer to the Appendix and apply any additional requirements specifically related to the Facility District in which the project is located.

E05.1.1. Aluminum

Applicable N/A

Number of base standards 1

Image Tool 250 x 188



Type: **Style 1**

Applies to: Group 1 Group 2 Group 3 Group 4 Other

Mfr: Kawneer

Color: Clear anodized

Finish: Factory

Model #: InFrame Interior Framing, (2x4 nominal framing)

Other: Satin stainless steel hardware

UFGS: Section 08 41 13 Aluminum-Framed Entrances and Storefronts
<http://www.wbdg.org/FFC/DOD/UFGS/UFGS 08 41 13.pdf>
 Section 08 71 00 Door Hardware
<https://www.wbdg.org/FFC/DOD/UFGS/UFGS 08 71 00.pdf>

E05.1.2. Hollow Metal

Applicable N/A

Number of base standards 2

Image Tool 250 x 188



Type: **Steel Doors**

Applies to: Group 1 Group 2 Group 3 Group 4 Other

Mfr: Steelcraft

Color: Neutral colors

Finish: Paint (Sheen per UFGS)

Model #: Hollow metal, 2" w. frames, 16 gauge (welded corners) grouted solid

Other: Provide in Group 3 and in utility areas of Group 1 and 2. Provide A25 "galvannealed" coating. All interior steel doors will have a factory applied primer finish. Provide satin stainless steel hardware.

UFGS: Section 08 11 13 Steel Doors and Frames

<http://www.wbdg.org/FFC/DOD/UFGS/UFGS 08 11 13.pdf>

Section 08 71 00 Door Hardware

<https://www.wbdg.org/FFC/DOD/UFGS/UFGS 08 71 00.pdf>

Type: **Steel Frames**

Applies to: Group 1 Group 2 Group 3 Group 4 Other

Mfr: Steelcraft

Color: Neutral colors

Finish: Paint (Sheen per UFGS)

Model #: Hollow metal, frame grouted solid

Other: Satin stainless steel hardware

UFGS: Section 08 11 13 Steel Doors and Frames

<http://www.wbdg.org/FFC/DOD/UFGS/UFGS 08 11 13.pdf>

Section 08 71 00 Door Hardware

<https://www.wbdg.org/FFC/DOD/UFGS/UFGS 08 71 00.pdf>

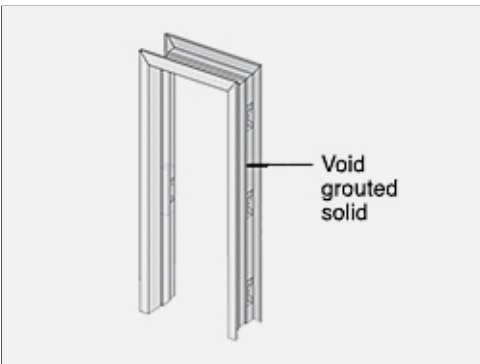

E05.1.3. Wood

Applicable N/A

Number of base standards 2

Image Tool 250 x 188



Type: **Style 1, Administrative**

Applies to: Group 1 Group 2 Group 3 Group 4 Other

Mfr: Simpson

Color: Natural hardwood veneer

Finish: Clear Sealer, satin (aqueous)

Model #: 3'x7'x 1 3/4", solid core

Other: Satin stainless steel hardware, Glass lites may be used. Stained birch veneer face, 5 ply construction, rotary cut finish.

UGFS: Section 08 14 00 Wood Doors

<http://www.wbdg.org/FFC/DOD/UGFS/UGFS 08 14 00.pdf>

Section 08 71 00 Door Hardware

<https://www.wbdg.org/FFC/DOD/UGFS/UGFS 08 71 00.pdf>

Type: **Style 2, Residential (Lodging)**

Applies to: Group 1 Group 2 Group 3 Group 4 Other

Mfr: Simpson

Color: Natural hardwood veneer or paint grade

Finish: Clear Sealer or paint, satin (aqueous)

Model #: Full slab or panels

Other: Satin nickel hardware

UGFS: Section 08 14 00 Wood Doors

<http://www.wbdg.org/FFC/DOD/UGFS/UGFS 08 14 00.pdf>

Section 08 71 00 Door Hardware

<https://www.wbdg.org/FFC/DOD/UGFS/UGFS 08 71 00.pdf>

E05.1.4. Other

Applicable N/A

E06. Casework Systems

E06.1. Casework Materials

1. Select casework systems and materials considering durability, maintenance requirements and LCCA.
2. Natural stone and cast stone countertops may only be used in Group 1 with approval on a case-by-case basis.
3. Metal cabinets and countertops will be provided in heavy-use operations and in Group 3.
4. Refer to AFCFS for approved materials.
5. Manufacturers listed below are only provided to establish a baseline of equivalency among all applicable manufacturers.

E06.1.1. Plastic Laminate

Applicable N/A

Number of base standards 1

Image Tool 250 x 188



Type: **Style 1, Low Use Areas**

Applies to: Group 1 Group 2 Group 3 Group 4 Other

Mfr: Formica

Color: Medium Earth tones and neutral tones

Finish: Light textured

Model #: High pressure laminate

Other: Combine with matching solid-surface banding on casework edges.

UGFS: Section 06 41 16.00 10 Plastic-Laminate-Clad Architectural Cabinets
<http://www.wbdg.org/FFC/DOD/UGFS/UGFS 06 41 16.00 10.pdf>

E06.1.2. Solid Polymer Surface

Applicable N/A

Number of base standards 1

Image Tool 250 x 188



Type: **Style 1, High Use Areas**

Applies to: Group 1 Group 2 Group 3 Group 4 Other

Mfr: Corian

Color: Medium Earth tones and neutral tones

Finish: Light textured

Model #: Solid Surface

Other: Faces and edge banding

UFGS: Section 12 36 00 Countertops

[http://www.wbdg.org/FFC/DOD/UFGS/UFGS 12 36 00.pdf](http://www.wbdg.org/FFC/DOD/UFGS/UFGS_12_36_00.pdf)

E06.1.3. Rapidly-Renewable Products

Applicable N/A

Number of base standards 1

Image Tool 250 x 188



Type: **Style 1 Moderate Use Areas**

Applies to: Group 1 Group 2 Group 3 Group 4 Other

Mfr: Plyboo

Color: Natural or amber

Finish: Satin

Model #: Flat grain bamboo plywood

Other: FSC® Certified 100%.

UFGS: Section 12 32 00 Manufactured Wood Casework

[http://www.wbdg.org/FFC/DOD/UFGS/UFGS 12 32 00.pdf](http://www.wbdg.org/FFC/DOD/UFGS/UFGS_12_32_00.pdf)

E06.1.4. Metal

Applicable N/A

Number of base standards 1

Image Tool 250 x 188



Type: **Style 1**

Applies to: Group 1 Group 2 Group 3 Group 4 Other

Mfr: Steel Sentry

Color: Natural stainless steel or neural colors (steel)

Finish: Mill (stainless) or Powder coated (steel)

Model #: Lab, workbench, computer workstation

Other: Provide highly durable fabrications and finishes in Group 3 which are subjected to heavy use.

UFGS: Section 12 31 00 Manufactured Metal Casework
<http://www.wbdg.org/FFC/DOD/UFGS/UFGS 12 31 00.pdf>

E06.1.5. Other

Applicable N/A

E06.2. Countertop Materials

E06.2.1. Plastic Laminate

Applicable N/A

Number of base standards 1

Image Tool 250 x 188



Type: **Style 1, Low Use Areas**

Applies to: Group 1 Group 2 Group 3 Group 4 Other

Mfr: Formica

Color: Medium Earth tones and neutral tones

Finish: Light textured

Model #: High pressure laminate

Other: Only use rounded half or full bullnose and integral backsplash. Do not use plastic laminate edge banding on front edges.

UFGS: Section 06 41 16.00 10 Plastic-Laminate-Clad Architectural Cabinets
http://www.wbdg.org/FFC/DOD/UFGS/UFGS_06_41_16.00_10.pdf

E06.2.2. Solid Polymer Surface

Applicable N/A

Number of base standards 1

Image Tool 250 x 188



Type: **Style 1, High Use Areas**

Applies to: Group 1 Group 2 Group 3 Group 4 Other

Mfr: Corian

Color: Medium Earth tones and neutral tones

Finish: Light textured

Model #: Solid Surface

Other: Faces and edges

UFGS: Section 12 36 00 Countertops
http://www.wbdg.org/FFC/DOD/UFGS/UFGS_12_36_00.pdf

E06.2.3. Natural Stone

Applicable N/A

Number of base standards 1

Image Tool 250 x 188



Type: **Style 1, Group 1 High Visibility, Heavy Use**

Applies to: Group 1 Group 2 Group 3 Group 4 Other

Mfr: Local (TBD)

Color: Neutral tones

Finish: High polish, sealer

Model #: Custom cut slabs

Other: N/A

UFGS: Section 12 36 00 Countertops

[http://www.wbdg.org/FFC/DOD/UFGS/UFGS 12 36 00.pdf](http://www.wbdg.org/FFC/DOD/UFGS/UFGS_12_36_00.pdf)

E06.2.4. Cast Stone

Applicable N/A

Number of base standards 1

Image Tool 250 x 188

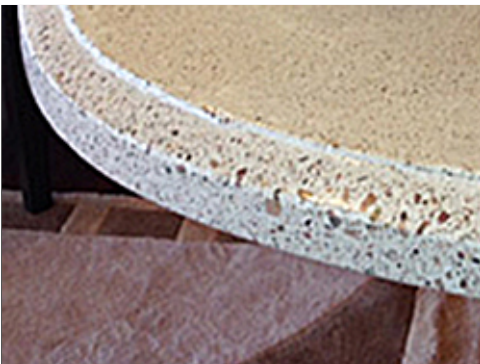

Type: **Style 1, Group 1 High Visibility, Heavy Use**

Applies to: Group 1 Group 2 Group 3 Group 4 Other

Mfr: Local (TBD)

Color: Neutral tones

Finish: High polish, sealer

Model #: Custom cast or cut slabs

Other: N/A

UFGS: Section 12 36 00 Countertops

[http://www.wbdg.org/FFC/DOD/UFGS/UFGS 12 36 00.pdf](http://www.wbdg.org/FFC/DOD/UFGS/UFGS_12_36_00.pdf)

E06.2.5. Metal

Applicable N/A

Number of base standards 1

Image Tool 250 x 188

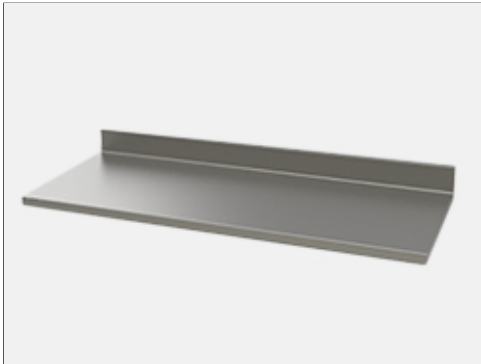

Type: _____

Applies to: Group 1 Group 2 Group 3 Group 4 Other

Mfr: Local (TBD)

Color: Natural stainless steel

Finish: Mill

Model #: Custom fabricated countertops

Other: Provide integral fronts, sides and backsplash

UFGS: Section 12 31 00 Manufactured Metal Casework
<http://www.wbdg.org/FFC/DOD/UFGS/UFGS 12 31 00.pdf>

E06.2.6. Other

Applicable N/A

E07. Furnishings

Comply with Air Force Corporate Standards for Furnishings:
<http://afcfs.wbdg.org/facilities-interiors/furnishings/index.html>

E07.1. Durability and Serviceability

Comply with AF Corporate Standards for Durability and Serviceability:
<http://afcfs.wbdg.org/facilities-interiors/furnishings/durability-and-serviceability/index.html>

E07.2. Accessories

Comply with AF Corporate Standards for Accessories:
<http://afcfs.wbdg.org/facilities-interiors/furnishings/accessories/index.html>

E08. Interior Signs

Comply with Air Force Corporate Standards for Interior Signs:
<http://afcfs.wbdg.org/facilities-interiors/interior-signs/index.html>

E08.1 Types and Color

Comply with Air Force Corporate Standards for Types and Color:
<http://afcs.wbdg.org/facilities-interiors/interior-signs/types-and-color/index.html>

E08.2. Interior Signs Materials

1. Natural stone, masonry and cast stone signs may only be used in Group 1 with approval on a case-by-case basis.

E09. Lighting, Power and Communication

<http://afcs.wbdg.org/facilities-interiors/lighting-power-and-communication/index.html>

E09.1. Functionality and Efficiency

Comply with Air Force Corporate Standards for Functionality and Efficiency:
<http://afcs.wbdg.org/facilities-interiors/lighting-power-and-communication/functionality-and-efficiency/index.html>

E09.2. Types and Color

Not Applicable

F. APPENDIX - Facility Districts

- Applicable
- N/A

Comply with Air Force Corporate Standards for Facility Districts:

<http://afcs.wbdg.org/facility-districts/index.html>

Facilities Districts Overview Map:

Image Tool 800 x 600

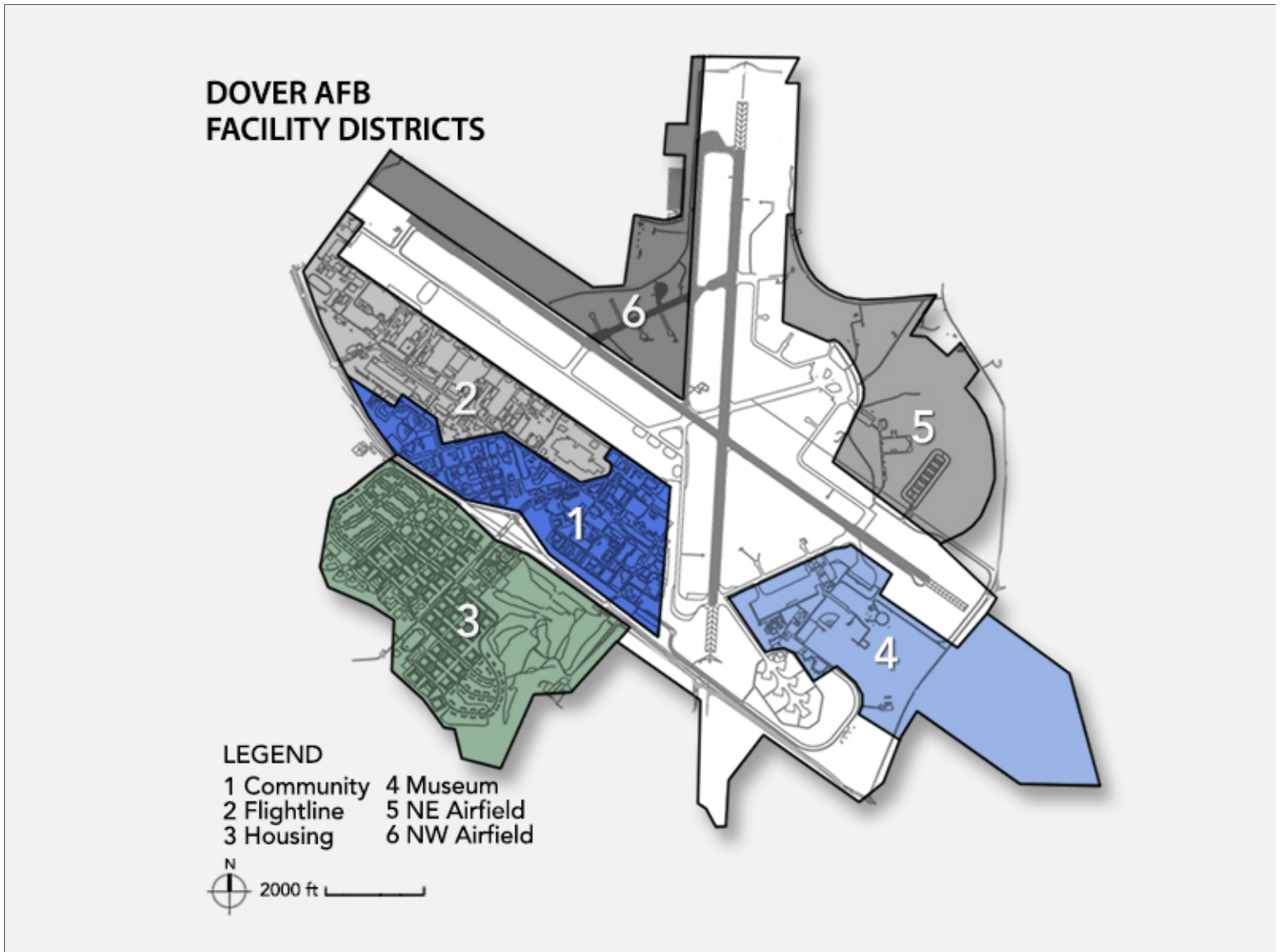

Note: Apply the base-wide standards in this IFS for Installation Elements, Site Development, Facilities Exteriors and Facilities Interiors (products, materials, color, etc.). Following application of the base-wide standards, refer to the Appendix and apply any additional requirements specifically related to the Facility District.

Enter No. of Facility Districts 1

The following Facility Districts list exceptions to the base standards that are unique to each district. Please refer to the Site Development, Facilities Exteriors, and Facilities Interiors sections of this IFS for base standards.

Image Tool 800 x 600

Map of District

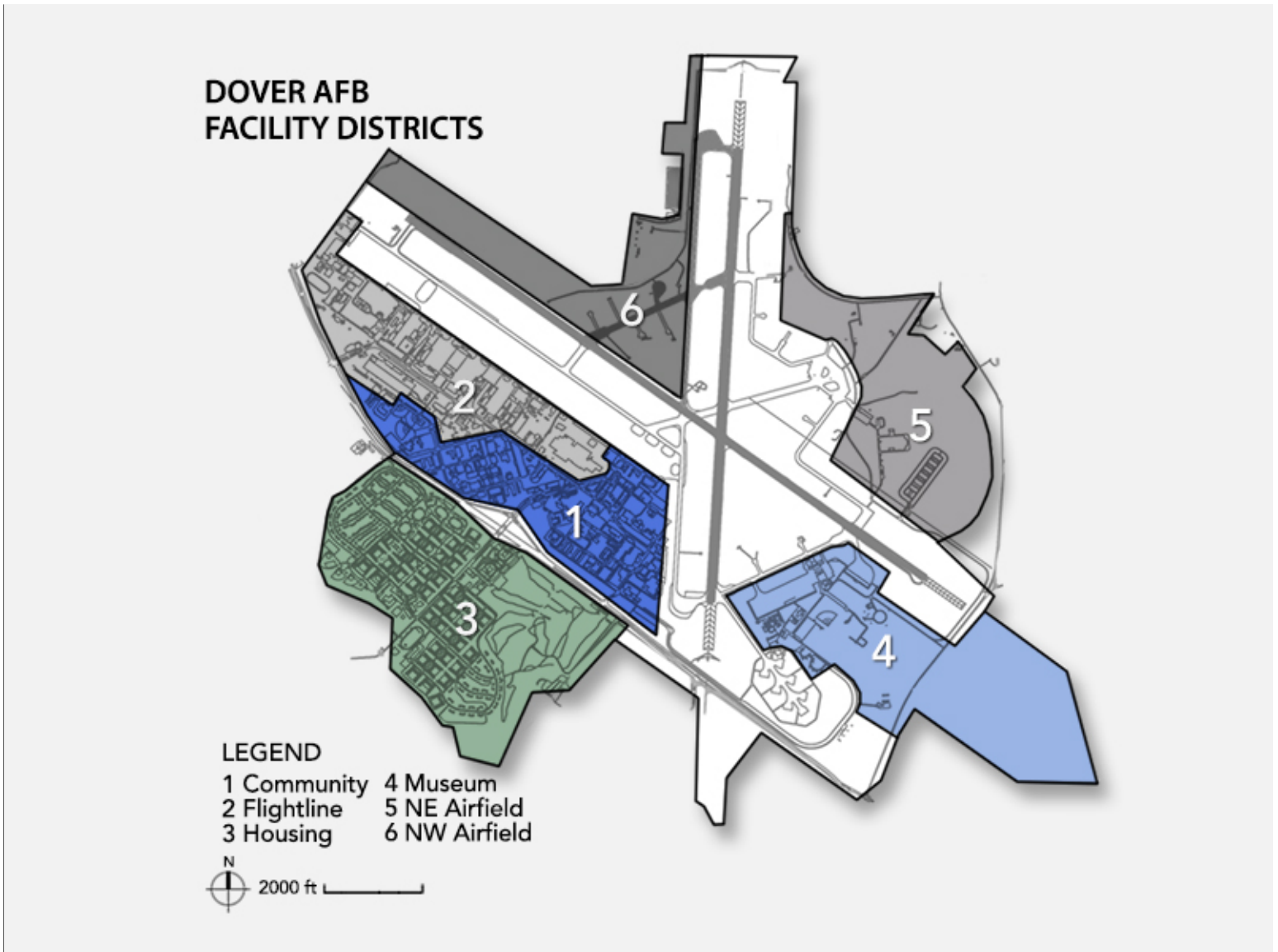

Photos for each facility group within the Facility District as applicable.

Image Tool 250 x 188

Group 1 Applicable N/A

Group 2 Applicable N/A

Group 3 Applicable N/A

Group 4 Applicable N/A

Other Applicable N/A

FACILITY DISTRICTS

Dover Air Force Base is divided into districts that align with land use zones as defined by the installation's General Plan. Each district has designated uses that help to define facility operations. Generally match adjacent facilities in new construction to promote architectural compatibility throughout the installation. Please refer to Section D03.2. and contact the Base Civil Engineer for additional information. A brief description of each of the districts follows.

1. Community Services

The Community Services District should be pedestrian in scale. Application of the installation prevailing architectural style should be implemented during major renovations or new construction as appropriate.

2. Flightline

The Flightline District includes the entire airfield pavement system (runway, taxiway and apron), related open space, navigational aids, and aircraft operations and maintenance facilities. Buildings in this district are mostly comprised of aircraft support facilities such as hangars, shops, and terminals and are industrial in nature and should remain so. Facilities should generally match adjacent buildings to ensure architectural compatibility and will follow standards for Facility Group 3 as defined in this IFS.

3. Family Housing

The Family Housing District consists of detached single family residential units occupied by enlisted and officer families. This area is currently under a housing privatization contract, but will follow standards for Facility Group 4 as defined in this IFS.

4. Museum

The Museum District should be monumental in scale. Application of the installation prevailing architectural style should be implemented during major renovations or new construction as appropriate. Facilities will generally follow the standards in this IFS for Group 2.

5. Northeast Airfield

The Northeast Airfield District will generally conform to the same IFS standards as the Flightline District: Generally match adjacent buildings to ensure architectural compatibility and follow standards for Facility Group 3.

6. Northwest Airfield

The Northwest Airfield District will generally conform to the same IFS standards as the Flightline District: Generally match adjacent buildings to ensure architectural compatibility and follow standards for Facility Group 3.

Open Space and Preserves

Open space includes undeveloped land both inside and outside of the immediate cantonment area. It both separates and defines the various sections of the base and creates a natural setting for the cantonment area. Areas classified as open space may be undeveloped to act as a buffer space between incompatible uses or for safety or security clearances or there may be other constraints that are not readily visible. All development in this district requires prior coordination and approval from the Base Civil Engineer.

G. APPENDIX - References

Comply with Air Force Corporate Standards:

<http://afcs.wbdg.org/index.html>

Note: The below listed Supplementary Documents are provided as supplements to this IFS. If there are any discrepancies between the requirements of this IFS and the Supplementary Documents, the IFS will govern.

436th CIVIL ENGINEER SQUADRON

G01 Dover AFB IFS Interior Finishes Supplement

https://www.wbdg.org/FFC/AF/AFIFS/G01_Dover_AFB_IFS_Interior_Finishes_Supplement.pdf

G02 Dover AFB IFS Environmental Supplement with Attachments

https://www.wbdg.org/FFC/AF/AFIFS/G02_Dover_AFB_IFS_Environmental_Supplement_with_Attachments.pdf