



Air Force Munitions Facilities Standards Guide

Volume I

ARCHIVED

31 May 2004



**U.S. AIR FORCE
MUNITIONS FACILITIES
STANDARDS GUIDE**

Volume I

31 May 2004

**Contract Number:
F41624-00-D-8028
Task Order 0217**



Prepared By:
URS Group, Inc.
7720 North 16th Street, Suite 100
Phoenix, AZ 85020

ARCHIVED



TABLE OF CONTENTS

CHAPTER 1: INTRODUCTION

1.1	PURPOSE AND SCOPE	1-1
1.2	APPROACH	1-1
1.3	USING THIS GUIDE	1-4

CHAPTER 2: PLANNING, PROGRAMMING, AND EXPLOSIVES SITE PLAN APPROVAL

2.1	GENERAL	2-1
2.2	PLANNING PROCESS	2-1
2.3	EXPLOSIVES SITE PLAN (ESP)	2-5
2.4	PROGRAMMING	2-10

CHAPTER 3: GENERAL DESIGN GUIDANCE

3.1	GENERAL	3-1
3.2	SITE DESIGN	3-2
3.3	EXTERIOR/STRUCTURAL DESIGN FOR FACILITIES	3-6
3.4	INTERIOR DESIGN	3-9
3.5	ENVIRONMENTAL SUPPORT SYSTEMS CRITERIA	3-13
3.6	TELECOMMUNICATIONS	3-19
3.7	SECURITY CRITERIA	3-19

CHAPTER 4: DESIGN STANDARDS

4.1	PURPOSE AND SCOPE	4-1
4.2	MAINTENANCE FACILITIES	4-3
4.3	STORAGE FACILITIES	4-53
4.4	TRANSPORTATION FACILITIES	4-109
4.5	MUNITIONS ADMINISTRATION FACILITIES	4-125

CHAPTER 5: REFERENCES, FORMS, ABBREVIATIONS AND ACRONYMS, AND TERMS

5.1	REFERENCES	5-1
5.2	FORMS	5-7
5.3	ABBREVIATIONS AND ACRONYMS	5-7
5.4	TERMS	5-11



ARCHIVED



LIST OF FIGURES

CHAPTER 1: INTRODUCTION

NO FIGURES

CHAPTER 2: PLANNING, PROGRAMMING, AND EXPLOSIVES SITE PLAN APPROVAL

FIGURE 2.1 A Multi-Discipline Project Team Facilitates the Planning Process..... 2-1
 FIGURE 2.2 Munitions Facility Approval Process..... 2-2
 FIGURE 2.3 ESP Approval Process 2-5
 FIGURE 2.4 MILCON Approval Process 2-10

CHAPTER 3: GENERAL DESIGN GUIDANCE

FIGURE 3.1 Concrete Parking Apron Outside Powered Trailer Maintenance Facility -
 Barksdale AFB, LA..... 3-2
 FIGURE 3.2 POV Parking - McChord AFB, WA 3-3
 FIGURE 3.3 Explosives/Hazard Symbol Signage - McChord AFB, WA 3-4
 FIGURE 3.4 Landscape at Weapons Release Systems Shop - Cannon AFB, NM..... 3-4
 FIGURE 3.5 Exterior Elevations Employ Non-Combustible Materials -
 Munitions Maintenance Facility - Cannon AFB, NM 3-5
 FIGURE 3.6 Steel Constructed K-Span - Above Ground Magazine -
 Cannon AFB, NM 3-6
 FIGURE 3.7 Frangible Roof Design - Multi-cubicle Magazine Storage Facility -
 Langley AFB, VA 3-7
 FIGURE 3.8 Facility Signage - McChord AFB, WA..... 3-7
 FIGURE 3.9 LPS (Catenary System) - Integrated Maintenance Facility -
 Barksdale AFB, LA..... 3-8
 FIGURE 3.10 Grounding System inside Flight Line Holding Facility -
 McChord AFB, WA 3-8
 FIGURE 3.11 Interior Wall Finish in Munitions Administration Facility -
 Barksdale AFB, LA..... 3-9
 FIGURE 3.12 Chemical Resistant Urethane on a Concrete Floor -
 Munitions Loading Crew Training Facility - Luke AFB, AZ..... 3-9
 FIGURE 3.13 Interior Lighting in Weapons and Release Systems Shop -
 Langley AFB, VA 3-11
 FIGURE 3.14 HVAC System for Surveillance and Inspection Shop -
 Langley AFB, VA 3-13
 FIGURE 3.15 Explosive-Proof Lighting in Flight Line Holding Facility -
 McChord AFB, WA..... 3-15
 FIGURE 3.16 Grounding System inside Flight Line Holding Facility -
 McChord AFB, WA..... 3-16
 FIGURE 3.17 Security Barriers Protecting Entrance to Munitions Storage Area -
 Cannon AFB, NM 3-19



Figure 3.18	Security Lighting on Segregated Magazine - Langley AFB, VA.....	3-19
Figure 3.19	High Security Hasp on Storage Igloo - Luke AFB, AZ.....	3-20

CHAPTER 4: DESIGN STANDARDS

FIGURE 4.1	Munitions Loading Crew Training Facility - Luke AFB, AZ	4-5
FIGURE 4.2	Munitions Loading Crew Training Facility - Cannon AFB, NM	4-6
FIGURE 4.3	IMF - Barksdale AFB, LA	4-13
FIGURE 4.4	IMF - Barksdale AFB, LA	4-13
FIGURE 4.5	Tactical Missile/Glide Weapon Maintenance Shop - Barksdale AFB, LA.....	4-17
FIGURE 4.6	Tactical Missile/Glide Weapon Maintenance Shop - Luke AFB, AZ	4-17
FIGURE 4.7	Tactical Missile/Glide Weapon Maintenance Shop - Langley AFB, VA.....	4-18
FIGURE 4.8	Weapons and Release System Shop - Cannon AFB, NM.....	4-25
FIGURE 4.9	Weapons and Release System Shop - Luke AFB, AZ.....	4-25
FIGURE 4.10	Surveillance and Inspection Shop - Langley AFB, VA.....	4-33
FIGURE 4.11	Surveillance and Inspection Shop - McChord AFB, WA	4-33
FIGURE 4.12	Conventional Munitions Maintenance Shop - Cannon AFB, NM.....	4-39
FIGURE 4.13	Conventional Munitions Maintenance Shop - Luke AFB, AZ	4-39
FIGURE 4.14	Powered Trailer Facility - Barksdale AFB, LA	4-49
FIGURE 4.15	Multi-cubicle Magazine Storage - McChord AFB, WA.....	4-55
FIGURE 4.16	Multi-cubicle Magazine Storage - Langley AFB, WA	4-55
FIGURE 4.17	Segregated Magazine Storage - Langley AFB, VA.....	4-67
FIGURE 4.18	Segregated Magazine Storage - Luke AFB, AZ	4-67
FIGURE 4.19	Segregated Magazine Storage - McChord AFB, WA.....	4-67
FIGURE 4.20	Above Ground Magazine Storage - Luke AFB, AZ	4-73
FIGURE 4.21	Storage Igloo - Cannon AFB, NM.....	4-73
FIGURE 4.22	Storage Igloo - Luke AFB, AZ	4-83
FIGURE 4.23	Inter Spares Storage - Luke AFB, AZ	4-91
FIGURE 4.24	Inter Spares Storage - Langley AFB, VA	4-91
FIGURE 4.25	Ancillary Explosives Facility Munitions Loading/Unloading Dock - Luke AFB, AZ	4-99
FIGURE 4.26	Ancillary Explosives Facility - MAC Pad at Cannon AFB, NM.....	4-99
FIGURE 4.27	Ancillary Explosives Facility - Barksdale AFB, LA	4-100
FIGURE 4.28	Dangerous Cargo Pad - McChord	4-111
FIGURE 4.29	Dangerous Cargo Pad - Langley AFB, VA	4-111
FIGURE 4.30	Munitions Holding Point - Luke AFB, AZ.....	4-115
FIGURE 4.31	Munitions Holding Point - McChord AFB, WA	4-115
FIGURE 4.32	Explosives Movement Route - Langley AFB, VA	4-119
FIGURE 4.33	Explosives Movement Route - Barksdale AFB, LA.....	4-119
FIGURE 4.34	Government Equipment Parking - Langley AFB, VA.....	4-121
FIGURE 4.35	Vehicle Parking - Barksdale AFB, LA	4-121



FIGURE 4.36 Government Equipment Parking - Luke AFB, AZ..... 4-122
FIGURE 4.37 Munitions Administration Facility - Luke AFB, AZ..... 4-127
FIGURE 4.38 Munitions Administration Facility - Cannon AFB, NM..... 4-127
FIGURE 4.39 Munitions Administration Facility - McChord AFB, WA 4-128

CHAPTER 5: REFERENCES, FORMS, ABBREVIATIONS AND ACRONYMS, AND TERMS

FIGURE 5.1 Typical Barricade Stack Relationship..... 5-15

ARCHIVED





TABLE OF ILLUSTRATED CATEGORY CODES

171-875	MUNITIONS LOADING CREW TRAINING FACILITY	4-7
212-212	MISSILE ASSEMBLY SHOP/INTEGRATED MAINTENANCE FACILITY (IMF)	4-15
212-213	TACTICAL MISSILE/GLIDE WEAPON MAINTENANCE SHOP	4-19
215-552	WEAPONS AND RELEASE SYSTEMS SHOP.....	4-27
215-582	SURVEILLANCE AND INSPECTION SHOP.....	4-35
216-642	CONVENTIONAL MUNITIONS MAINTENANCE SHOP.....	4-41
218-712	AIRCRAFT SUPPORT EQUIPMENT SHOP/STORAGE FACILITY – USED FOR MUNITIONS SUPPORT EQUIPMENT MAINTENANCE.....	4-51
422-253	MULTI-CUBICLE MAGAZINE STORAGE.....	4-57
422-256	ROCKET CHECK OUT AND ASSEMBLY STORAGE.....	4-65
422-257	SEGREGATED MAGAZINE STORAGE.....	4-69
422-258	ABOVE GROUND MAGAZINE STORAGE.....	4-75
422-264	STORAGE IGLOO.....	4-85
422-265	INERT SPARES STORAGE	4-93
422-271	MODULE BARRICADED STORAGE	4-97
422-275	ANCILLARY EXPLOSIVES FACILITY.....	4-103
116-662	PAD, DANGEROUS CARGO	4-113
422-277	MUNITIONS HOLDING POINT.....	4-117
610-144	MUNITIONS ADMINISTRATION FACILITY	4-131

ARCHIVED





TABLE OF CONTENTS

CHAPTER 1: INTRODUCTION

1.1	PURPOSE AND SCOPE.....	1-1
1.2	APPROACH.....	1-1
1.2.1	Document Organization.....	1-1
1.2.2	Maintenance Facilities.....	1-2
1.2.3	Storage Facilities.....	1-3
1.2.4	Transportation Facilities.....	1-3
1.2.5	Administrative Facilities.....	1-3
1.3	USING THIS GUIDE.....	1-4
1.3.1	Hyperlinks.....	1-4
1.3.2	Drawings.....	1-4

ARCHIVED





1.1 Purpose and Scope

This guide addresses criteria and standards for planning and programming 21 of the most common non-nuclear munitions facilities on United States Air Force (USAF) installations both within the continental United States (CONUS) and at overseas locations (OCONUS). They include active duty Air Force, Air National Guard (ANG), and Air Force Reserve Command (AFRC) facilities. This guide is not all-inclusive and may not cover unique mission or facility requirements. It lists criteria and standards for munitions facility planning and programming that are addressed by civil engineering (CE), weapons safety, munitions, security forces, communications and others involved in the review. The criteria also apply to the repair, renovation, and expansion of Air Force munitions facilities that require significant improvements to meet safety, security, and operational mission requirements.

The siting and construction of Air Force munitions facilities in foreign countries must comply with these guidelines as well as host nation requirements. Where United States and host nation requirements differ, the more restrictive criteria shall apply.

1.2 Approach

This document provides planning, site selection guidance, and design standards for munitions-related facilities. Most of these facilities will be located in the munitions storage area (MSA), an area designated for the storage and maintenance of large quantities of explosive materials. Facilities are categorized by CE Real Property Category Codes (Cat Codes). Facility function, type of construction, planning factors, and design criteria are organized in this document according to Cat Code. Each of the 21 munitions facilities covered by this guide can be placed into four distinct classes based on function and similar design features: Maintenance, Storage, Transportation, and Administrative.

1.2.1

Document Organization

The following paragraphs provide an overview of the contents that comprise this two-volume guide.

Volume I is organized to facilitate munitions facility planning, programming, and design process. An overview of each chapter follows:

Chapter 1: Introduction. This chapter explains the use and organization of this guide.



- Chapter 2: Planning, Programming, and Explosives Site Plan Approval.** This chapter explains the CE planning and programming process to the munitions user to better understand the steps associated with project development, funding, and construction. It also provides general guidance for use by the installation's Weapons Safety Manager (WSM) and CE to develop an explosives site plan (ESP) package for a project.
- Chapter 3: General Design Guidance.** This chapter provides general design standards common to munitions facilities. It discusses common issues such as site layout, architectural and structural requirements, safety, force protection, and security standards.
- Chapter 4: Design Standards.** This chapter provides specific and unique design standards for each of the 21 facilities types addressed in this guide. To the maximum extent possible, this chapter includes floor plans, elevations, and photographs to assist in the design of new munitions facilities. The designs included in this chapter are considered as the "best in class" for each of the facility types discussed in this document. In some cases, there are several designs from which to choose, all of which meet the standards for that facility type.
- Chapter 5: References, Forms, Abbreviations and Acronyms, and Terms.** This chapter provides references, including DoD, Army, Navy, Air Force, national code standards, related guidance, and information that can be used in conjunction with this guide.

Volume II, Munitions Facilities Assessment Checklists. Volume II contains condition assessment checklists for each of the 21 facility types covered in this guide.

1.2.2 Maintenance Facilities

Maintenance facilities are defined as those facilities where munitions and related support equipment are inspected, assembled, repaired, and maintained. The applicable Cat Codes are:

- 171-875 Munitions Loading Crew Training Facility
- 212-212 Missile Assembly Shop/Integrated Maintenance Facility (IMF)
- 212-213 Tactical Missile/Glide Weapons Maintenance Shop
- 215-552 Weapons and Release Systems Shop
- 215-582 Surveillance and Inspection Shop
- 216-642 Conventional Munitions Shop



218-712 Aircraft Support Equipment Shop/Storage Facility (Aerospace Ground Equipment (AGE) Facility) – Used for Munitions Support Equipment Maintenance

1.2.3

Storage Facilities

Storage facilities are those facilities where large quantities of munitions are stored for extended periods of time. These facilities include magazines (earth-covered or above ground), multi-cubes, open buildings/warehouses, sheds, inert spares, and open pads. The applicable Cat Codes are:

422-253 Multi-cubicle Magazine Storage
422-256 Rocket Check Out and Assembly Storage
422-257 Segregated Magazine Storage
422-258 Above Ground Magazine Storage
422-264 Storage Igloo (Earth-covered Magazine)
422-265 Inert Spares Storage
422-271 Module Barricaded Storage
422-275 Ancillary Explosives Facility (Classification Yards, Holding Yard, Inspection Station, Interchange Yard, Loading Dock, Ready Explosives Facility, and Bomb Preload Station/Munitions Assembly Conveyor (MAC) pad)

1.2.4

Transportation Facilities

Transportation facilities are defined as those facilities that support the transportation, movement and temporary storage of munitions. The applicable Cat Codes are:

116-662 Pad, Dangerous Cargo
422-277 Flight Line Munitions Holding Point
851-147 Roads (Streets) – Primary and Alternate Explosives Movement Routes
852-261 Vehicle Parking Operations – Used for Munitions Sub Pool Parking
890-158 Load and Unload Platform (Railhead) – Used for Munitions Operations

1.2.5

Administrative Facilities

Administrative facilities (squadron or flight) typically include office and training space for munitions personnel. These facilities house administrative functions including quality assurance, Munitions Control, flight/squadron offices, training rooms, break rooms, and other munitions



support functions usually housed in a stand alone facility. For the purpose of this guide, Line Delivery and Storage Dispatch functions fall under this Cat Code. Administrative areas (field offices) located within munitions operations facilities are discussed as part of the primary functional facility requirements in Chapter 4, Design Standards, of this guide. The Cat Code for munitions administration facilities is:

610-144 Munitions Administration Facility

1.3 Using This Guide

This guide contains two volumes. Volume I provides the standards for planning, programming, and designing munitions facilities. It also references supporting publications focused on a variety of explosives-related topics (see Chapter 5, “References, Forms, Abbreviations and Acronyms, and Terms”). The intent is to provide guidelines and hyperlinks to other resources that will assist the user in designing munitions facilities. It assists munitions personnel in understanding the process for programming, planning, and designing facilities to support munitions operations. It also assists CE personnel and designers in understanding functional requirements for munitions facilities.

The facilities assessment checklists, included in Volume II, are used to evaluate the condition of existing facilities and compare them against the standards contained in this document. These checklists may also be used to assist in the planning process for new construction. The checklists are easily downloaded and provide a standardized format for munitions facilities condition assessment.

1.3.1 Hyperlinks

Hyperlinks (**[bolded blue, underlined text](#)**) are used to provide electronic access to related documents and reference material. In most cases, they provide direct access to key Department of Defense (DoD) and Air Force documents, national code standards, and other information necessary to plan, program, and design munitions facilities. Some of the hyperlinks provide access to an information directory that includes a link to the referenced material, or provides instruction on how to acquire it. In the event a hyperlink does not work, please notify the referenced document’s office of primary responsibility (OPR).

1.3.2 Drawings

Some munitions facilities have standardized designs that are Department of Defense Explosives Safety Board (DDESB)-approved and may be applicable for use in new construction (e.g., storage igloo, segregated magazine storage). These designs may be used “as-is” or can be site-adapted to meet mission or site requirements. Chapter 4, “Design



Standards” includes “best in class” designs for each of the facility types discussed in this document.

Designs for some munitions facilities do not require DDESB approval (e.g., pre-engineered steel buildings, loading docks). “Best in class” designs for each of these facility types are also provided in Chapter 4, “Design Standards.” These drawings identify prime examples of features used in new construction and the modification of existing munitions facilities. Although construction design is not approved by the DDESB, explosives siting approval or licensing may be required dependent upon a facility’s function and location.

ARCHIVED





TABLE OF CONTENTS

CHAPTER 2: PLANNING, PROGRAMMING, AND EXPLOSIVES SITE PLAN APPROVAL

2.1	GENERAL	2-1
2.2	PLANNING PROCESS	2-1
2.2.1	Identify Needs	2-2
2.2.2	Establish/Validate Requirements	2-3
2.2.3	Evaluate Alternatives	2-3
2.2.4	Select Preferred Alternative	2-4
2.2.5	Obtain Approvals	2-5
2.3	EXPLOSIVES SITE PLAN (ESP)	2-5
2.3.1	Explosives Site Plan Package	2-6
2.3.1.1	AF Form 943, Explosives Safety Site Plan/Waiver/ Exemption	2-6
2.3.1.2	Transmittal Letter	2-7
2.3.1.3	Commander's Risk Assessment	2-7
2.3.1.4	Map	2-7
2.3.1.5	Facility Drawings	2-7
2.3.1.6	Exception to Policy Letter	2-7
2.3.2	ESP Organization Responsibilities	2-8
2.3.2.1	Using Organization	2-8
2.3.2.2	Civil Engineer	2-8
2.3.2.3	Weapons Safety Manager	2-8
2.3.2.4	Wing/Installation Commander	2-9
2.3.2.5	MAJCOM Weapons Safety Office (SEW)	2-9
2.3.2.6	MAJCOM Commander	2-9
2.3.2.7	Air Force Safety Center Weapons Safety Staff (AFSC/SEW)	2-9
2.3.2.8	Department of Defense Explosives Safety Board (DDESB)	2-9
2.4	PROGRAMMING	2-10
2.4.1	Military Construction (MILCON)	2-10
2.4.2	Operations and Maintenance (O&M) Program	2-11





LIST OF FIGURES

CHAPTER 2: PLANNING, PROGRAMMING, AND EXPLOSIVES SITE PLAN APPROVAL

FIGURE 2.1	A Multi-discipline Project Team Facilitates the Planning Process	2-1
FIGURE 2.2	Munitions Facility Approval Process	2-2
FIGURE 2.3	ESP Approval Process.....	2-5
FIGURE 2.4	MILCON Approval Process.....	2-10

ARCHIVED





CHAPTER 2

PLANNING, PROGRAMMING, AND EXPLOSIVES SITE PLAN APPROVAL

2.1 General

This chapter discusses the planning, programming, and explosives site plan (ESP) approval processes for munitions facility projects and describes the roles and responsibilities of the organizations involved in developing and approving munitions projects. The purpose of this chapter is to improve understanding among the functional players regarding roles, responsibilities, and functions of the inter-disciplinary team members.



Figure 2.1
A Multi-discipline Project Team
Facilitates the Planning
Process

Using a team approach upon project initiation ensures a well communicated and coordinated process. The team should include representatives from civil engineering (CE), munitions, weapons safety, security forces, communications, bio-environmental, and other organizations identified in the planning process. Early coordination with the Air Force Major Command (MAJCOM), Air Force Safety Center (AFSC), and the Department of Defense Explosives Safety Board (DDESB) is critical and should be accomplished through the appropriate installation level points of contact (POCs). The Wing/Installation Commander will provide the final approval for the facility requirements at the installation level.

2.2 Planning Process

Planning is essential to meet mission requirements while satisfying established facility, safety, and operational criteria. Due to the potentially lengthy ESP approval process, it is very important the planning/programming and ESP processes are initiated concurrently to prevent delays in actual construction. As shown in Figure 2.2, the munitions facility planning and approval process consists of the following five steps:

1. Identify Needs
2. Establish/Validate Requirements
3. Evaluate Alternatives
4. Select Preferred Alternative
5. Obtain Approvals



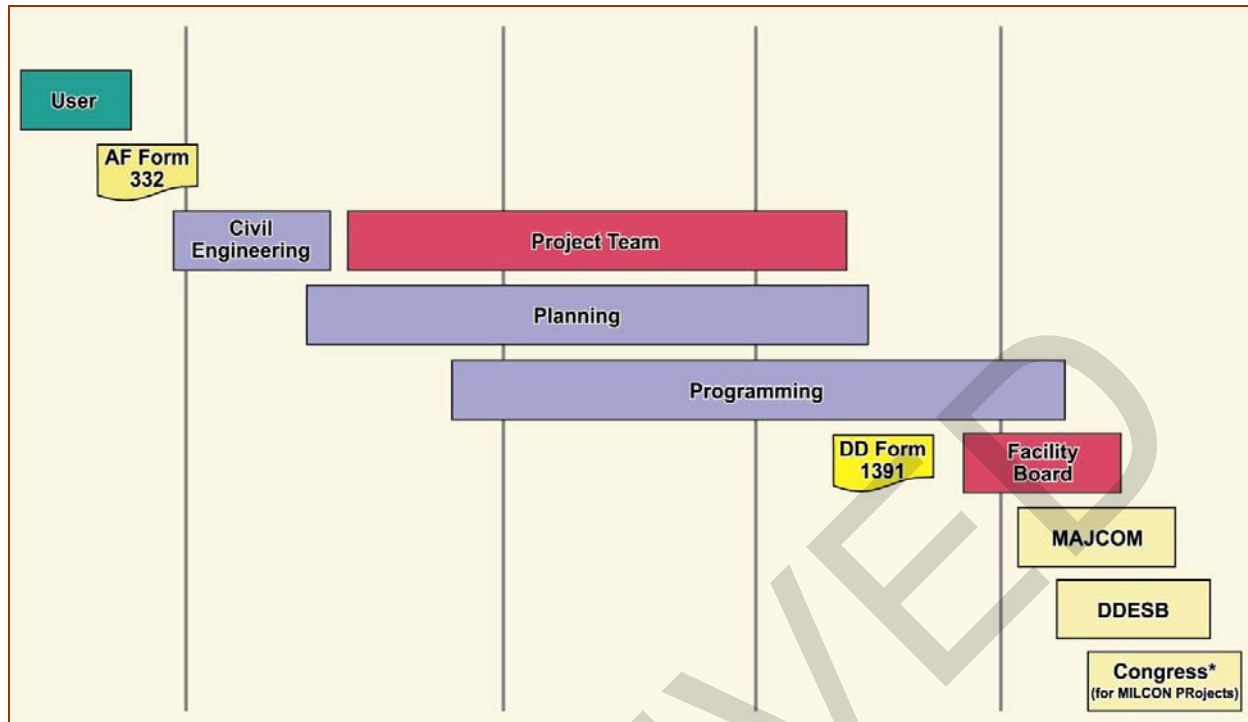

Figure 2.2
Munitions Facility Approval Process

2.2.1 Identify Needs

The planning process begins with the functional user submitting an [AF Form 332, Base Civil Engineer Work Request](#), to the Base Civil Engineer (BCE). The requestor uses this form to identify proposed actions necessary to meet mission requirements and provides the basic information and justification that the BCE needs to evaluate the request and verify the need for the facility action. Specific needs are validated through:

1. Interviews with the requesting unit
2. Project team input
3. Air Force guidelines consultation
4. Review and evaluation of existing facilities

It may help to review [AFI 36-2217, Munitions Requirements for Aircrew Training](#), [AFCAT 21-209, Volume 1, Ground Munitions](#), and [AFI 10-503, Base Unit Beddown Program](#), as a precursor to calculating current and future needs.



Quantity-Distance (Q-D)

Q-D refers to the relationship between the quantity of explosive materials and the separation distance required to provide a certain degree of protection from an accidental explosion.

Q-D distances are measured from Potential Explosion Site (PES) to Exposed Site(s). The formula, $D=K \times 3\sqrt{W}$, is used to calculate Q-D requirements, where:

D = required distance in feet;

K = protection factor depending on the risk assumed or permitted;

$3\sqrt{W}$ = cube root of the net explosive weight (in pounds).

Please refer to [AFMAN 91-201](#) for more information on K factors and calculating Q-Ds.

Types of Q-D separations are defined in Chapter 5 of this document.

Explosives Clear Zone

The area around a PES that is determined by the required inhabited building distance (IBD) separation. The IB separation will be based on the sited, waived, exempted, or actual explosives limits of the PES site, whichever is greatest.

2.2.2 Establish/Validate Requirements

Based on information provided by the user on [AF Form 332](#), the BCE will match the request with the appropriate facility type using CE Real Property Category Codes (Cat Codes) and conduct a facility needs assessment.

2.2.3 Evaluate Alternatives

CE and the Weapons Safety Manager (WSM) will consider alternatives to new construction such as renovation, replacement, or reassignment/conversion of facilities to meet the facility requirement. Each alternative will be evaluated using the following siting factors:

1. **Location.** Munitions storage and handling facilities should be sited within the installation's explosives clear zone. The facility location, where possible, should avoid creating Quantity-Distance (Q-D) violations. In some cases, a munitions facility may be located outside the explosives clear zone (or an installation may not have one established), and will require an explosives license (e.g., an armament shop, load crew training facility, and rocket check out and assembly facility). For additional information on licensing requirements, see [AFMAN 91-201](#), *Explosives Safety Standards*.
2. **Natural Environment.** The area should be assessed for grade, drainage, wetlands, flood plains, highly erodible soils, and shrink/swell conditions. See Section 3.2, "Site Design" for details.
3. **Size.** Site size depends primarily on the planned facility's function, square footage, and Q-D requirements. Site size calculations must accommodate anti-terrorism and force protection criteria, parking, and munitions handling and loading requirements and vehicle movement.
4. **Orientation.** As much as possible, the designer should orient the facility to take full advantage of the local site climate, considering factors such as wind, glare, and solar loading on the building and its physical plant equipment when possible. Facility orientation is also influenced by the Q-D requirements on the selected site as outlined in [AFMAN 91-201](#).
5. **Access.** The site should have adequate space to develop vehicle and pedestrian systems that allow for functional site access, circulation, and parking. The roadway network within the munitions storage area (MSA) should provide more than just one egress route from munitions facilities. It must also provide direct access to and from approved explosives traffic routes.



6. **Site Utilities.** The designer should ensure adequate potable water, sanitary sewer, electrical, and communications services to the site are provided as required by the facility function. Design and installation of site utilities must be in accordance with installation, MAJCOM, Air Force, and Department of Defense (DoD) standards. See Chapter 3, “General Design Standards” for more details on these items.
7. **Landscaping.** Vegetation control and landscaping should be used to enhance security and safety requirements. Erosion control is a primary use of new landscaping.
8. **Fire Protection.** When considering site utilities, the designer should ensure an adequate water supply (quantity and pressure) is available to suppress potential fires. If adequate supplies of water are not available to the location, alternative fire protection methods, such as dry chemical extinguisher, should be considered. The site must be large enough to accommodate firebreaks and allow direct vehicular access for firefighting equipment.
9. **Security and Force Protection.** When selecting sites, consider anti-terrorism/force protection stand-off requirements, resource protection, communications, and electronic security. Planning must include security measures (e.g., use of natural and man-made barriers, site distance, etc.) to meet Force Protection Condition (FPCON) requirements based on the type of assets located in the storage, operational, and administrative facilities.
10. **Work Flow.** The site should be designed to accommodate the efficient input and output of the munitions assets being inspected, stored, or maintained. Consider requirements for loading docks and government owned vehicle (GOV)/ equipment parking locations.
11. **Functional Relationships.** Facilities should be located to enhance the supplier-customer relationship (e.g., ready use storage area in close proximity to the flight line, missile maintenance facility proximate to the missile storage facility, etc.) and minimize the distance between functions while complying with Q-D criteria.

The considerations listed above provide a basic framework for the project team in determining the optimum facility site.

2.2.4 Select Preferred Alternative

The project team will select a preferred alternative based on analysis of the alternatives identified. A risk assessment should be made of the impact on the mission if a mishap occurs using the Operational Risk

Force Protection Stand-Off Requirements

A distance between an asset and a threat is referred to as a *stand-off distance*. There is no ideal stand-off distance; it is determined by the type and level of the threat, the type of construction, and desired level of protection. See [UFC 4-010-01](#), *DoD Minimum Antiterrorism Standards for Buildings*, [DODI 2000.16](#), *DoD Antiterrorism Standards*, and the [U.S. Air Force Installation Force Protection Guide](#).



Management (ORM) process as outlined in the text box on page 2-7. Compensatory measures (e.g., earth barricades, etc.) should be factored into site improvements to minimize the damage of a maximum credible event (MCE). A MCE is defined as the largest quantity of explosives expected to explode at one time when an item in a stack or group of items is initiated or when explosives are stored at less than intermagazine distance apart. In determining the preferred alternative, the project team will consider other factors including cost, feasibility, and project completion date. The selected alternative must provide a workable solution for all involved parties without compromising the base's mission, safety, or the project's feasibility.

2.2.5 Obtain Approvals

The Wing/Installation Commander assumes responsibility for the risk associated with siting explosives operations and facilities. These risks are formalized in the ESP package submitted to the DDESB for approval.

2.3 Explosives Site Plan (ESP)

Cardinal Principle of Explosives Safety

Expose the minimum number of people to the minimum amount of explosives for the minimum amount of time. (AFMAN 91-201)

The Cardinal Principle of Explosives Safety is the foundation for selecting the right location for munitions facilities. The ESP is the product of the explosives site planning process for constructing or renovating explosives-related munitions facilities within the explosives clear zone. It details plans for locating explosive operations and facilities to minimize the potential effects of an accidental explosion on other assets, capabilities, and surrounding areas. The ESP is a key document used by management to enhance the safety of activities in an explosives clear zone and the areas surrounding a potential explosion site (PES). Figure 2.3 illustrates the ESP approval process.

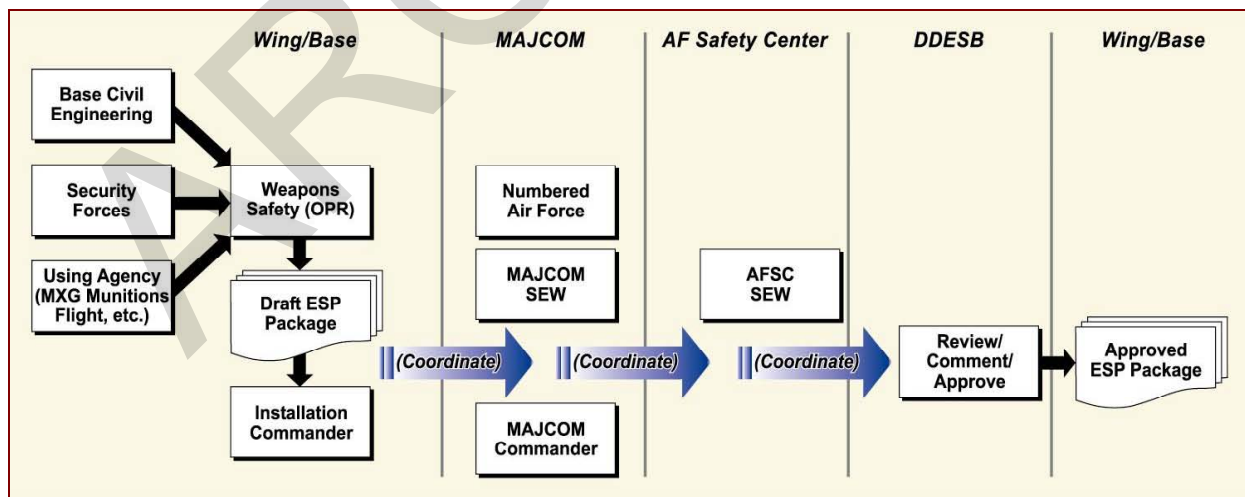

Figure 2.3
ESP Approval Process



An ESP is required whenever:

1. new facilities or operations are added,
2. the facility function is changed inside the installation's explosives clear zone, and/or
3. any new construction that will involve storage, maintenance, or other operations involving explosives.

An ESP is not required where a license has been issued to store munitions outside the MSA. It is extremely important to establish the ESP at the onset of the planning/programming process so the location may be assessed for impacts on Q-D requirements of munitions-related facilities and operations.

2.3.1 Explosives Site Plan Package

The installation WSM prepares and submits ESP packages with assistance from civil engineering, munitions, and other organizations. An ESP package contains all of the information necessary for the MAJCOM, AFSC, and DDESB reviewers to determine whether DoD and Air Force explosives safety requirements are met. [AFMAN 91-201](#) and [DoD 6055.9-STD](#), *DoD Ammunition and Explosives Safety Standards*, contain the primary instructions for siting explosives facilities. The former provides detailed and systematic guidance for preparing an ESP package for submission, while the latter provides direction on the Services' explosives safety requirements. The exact content of an ESP package may vary depending on the operation/facility being sited, but in general will include some or all of the following documents described in the following sections.

2.3.1.1 AF Form 943, Explosives Safety Site Plan/Waiver/ Exemption

This form includes a brief facility/operations description along with proposed explosives limits, location, and the hazard/class of the explosives to be stored or maintained in the facility. It also lists all exposed sites (ES) and PESs affected by Q-D requirements for the proposed facility. A comparison of the actual distance of the ES from the PES will determine if a Q-D violation exists, and if a waiver, exemption, or deviation is required (see Chapter 5, "References, Forms, Abbreviations and Acronyms, and Terms"). An evaluation of the proposed action must include the following:

1. **Impact on Mission if Mishap Occurs.** This section of the [AF Form 943](#) analyzes the effects of an MCE on the future of a mission, other facilities, and human health and safety. The level of risk the commander will assume with the new facility/operation is determined based on the MCE.

Additional Resources for Explosives Site Plans (ESP)

The following web site links provide additional information useful in the development of an ESP.

[Assessment System for Hazard Surveys \(ASHS\)](#)

A computer-generated tool that automates the site planning process.

[AFI 32-7062, USAF](#)

Comprehensive Planning- Defines BCE roles and responsibilities regarding explosives site planning.

[OO-ALC Weapons Safety Home Page](#)

Provides several automated tools to calculate Q-D requirements for the ESP.

[Department of Defense Explosives Safety Board](#)

(DDESB)- Contains general information relating to DoD explosives safety policy decisions, explosives site planning, and links to other sites.

[Air Force Civil Engineer Support Agency](#)

(AFCESA)- Provides useful product and service information regarding lightning protection systems (LPS) and electrical ground systems.

[Air Force Safety Center](#)

(AFSC)- Provides Air Force-level review of all ESPs.



Operational Risk Management (ORM)

- For methods in reducing or eliminating risks in support of the ORM six-step process, refer to [AFPAM 90-902](#), *Operational Risk Management (ORM) Guidelines and Tools*.
- Use [AFMAN 91-201](#) and [AFI 90-901](#), *Operational Risk Management (ORM)*, as the primary source documents to calculate mission requirements and risks associated with a facility project.
- The following six-step ORM process applies to the ESP: (The entire ORM process and mandated training for all Air Force personnel is found in [AFI 90-901](#).)
 1. Identify the hazards.
 2. Assess the risk.
 3. Analyze risk control measures.
 4. Make control decisions.
 5. Implement risk controls.
 6. Supervise and review.

2. **Action Taken to Minimize Risk.** This section of the AF Form 943 explains compensatory measures implemented to minimize the damage of a MCE.
3. **Justification or Impact on Mission if Site Plan is not Approved.** This section of the AF Form 943 explains why the proposed facility is required and justifies why this action is recommended. It explains the mission impact if the requested action is not approved.

2.3.1.2 Transmittal Letter

The transmittal letter explains the purpose of the ESP, identifies explosives safety issues, describes compensatory measures, and clarifies other issues affecting the project.

2.3.1.3 Commander's Risk Assessment

If the PES and ES relationship does not meet Q-D criteria, the Base/Wing Commanders will perform a project risk assessment to be summarized in the exception decision nomograph to be attached to the transmittal letter. Refer to [AFMAN 91-201](#) for guidance in preparing the nomograph. Projects not meeting Q-D criteria will require an exemption waiver.

2.3.1.4 Map

The ESP must contain a map illustrating proposed facilities and all PESs and ESSs covered by the ESP.

2.3.1.5 Facility Drawings

Drawings should show applicable safety and protection features. If required, these drawings must show, as a minimum, the applicable safety and protective features to include dividing walls, vent walls, firewalls, roofs, operational equipment, ventilation systems and equipment, hazardous waste disposal systems, lightning protection and static grounding systems, process equipment, windows, floor layout, auxiliary support structures, and general construction materials.

2.3.1.6 Exception to Policy Letter

Departure from the standards in [AFMAN 91-201](#) may necessitate an exception to policy letter. Such exceptions may necessitate a Q-D waiver or exemption (i.e., not able to meet Q-D criteria), or a deviation from explosives safety policy (e.g., lacking lightning protection, too large of rocks in igloo earth covering material, etc.) if it is not possible to meet all of the rules of AFMAN 91-201 for the munitions facility construction project. The WSM will determine if an exception is needed to depart from the rules stipulated in [AFMAN 91-201](#).

1. **Waiver.** Applies to short-term violations of Q-D requirements that will be resolved within 5 years. The waiver includes proposed corrective action and anticipated get-well date.



2. **Exemption.** A relatively long-term departure from Q-D criteria (takes more than 5 years to resolve, or is a permanent departure from Q-D standards). If not a permanent exception, the exemption shall include a proposed fix date and plan of action to correct the deficient situation.
 - a. Use the [AF Form 943](#) to submit waivers and exemptions. The approval level for the waivers and exemptions varies depending on the duration of the problem, mission, level of risk, and period of time since a facility was constructed.
3. **Deviation.** Submit a deviation request when Q-D criteria are not compromised but there is a deficiency in meeting the other standards in [AFMAN 91-201](#). Use a memorandum to up-channel deviations to the approval level determined by the MAJCOM.

2.3.2 ESP Organization Responsibilities

The responsibilities of the personnel involved in the preparation and approval of the ESP are detailed below.

2.3.2.1 Using Organization

The using organization identifies a space or facility requirement based on a new mission, expanding mission, or the inadequate/substandard condition of current facilities. The using organization submits the requirement to CE via the [AF Form 332](#). The using organization coordinates with the organizations identified in the installation's Facility Project Manager Handbook. The using organization will maintain a copy of their submittals on file.

2.3.2.2 Civil Engineer

CE processes the [AF Form 332](#). CE will assist the WSM by providing the maps and/or drawings as applicable. CE will also ensure the WSM is apprised of all proposed actions planned within the explosives clear zone before design and construction begins.

2.3.2.3 Weapons Safety Manager

The WSM is notified of the facility requirement during the [AF Form 332](#) coordination process. The WSM determines the need for an ESP and coordinates with the using organization and the BCE to prepare the ESP. The WSM submits an ESP package using the Assessment System for Hazard Surveys (ASHS) whenever possible, or manually prepares an [AF Form 943](#). See [AFMAN 91-201](#) for an example of a completed AF Form 943. The WSM will maintain a file of all approved ESPs.



2.3.2.4 Wing/Installation Commander

The Wing/Installation Commander reviews the project plan and may or may not concur with the action. The Commander may offer recommendations, changes, or request further analysis. The Wing/Installation Commander's signature on the AF Form 943 represents his/her acceptance of all explosives safety risks, with or without exceptions, contained in the ESP package.

2.3.2.5 MAJCOM Weapons Safety Office (SEW)

The ESP package is forwarded to the MAJCOM/SEW with an information copy sent to the respective Numbered Air Force. The MAJCOM/SEW reviews the ESP package and may request clarification from the originator if questions arise or additional information is needed.

2.3.2.6 MAJCOM Commander

After the MAJCOM/SEW reviews and concurs with the ESP, the ESP is forwarded to the MAJCOM Commander for his/her signature on the AF Form 943. Upon MAJCOM Commander concurrence, the MAJCOM/SEW forwards the ESP to the Air Force Safety Center (AFSC).

2.3.2.7 Air Force Safety Center Weapons Safety Staff (AFSC/SEW)

AFSC/SEW is tasked with the primary responsibility for Air Force explosives safety. AFSC/SEW reviews all ESPs prior to forwarding them to the DDESB for approval.

2.3.2.8 Department of Defense Explosives Safety Board (DDESB)

The DDESB reviews and approves all ESPs prior to any construction. The DDESB will notify AFSC/SEW via a letter of approval. In an event the ESP is disapproved, the DDESB provides a memorandum explaining the reason for disapproval.

Air Force Safety Center (AFSC)

AFSC is the Air Force OPR for missile, nuclear, explosives, flight, space, and ground safety matters. AFSC analyzes and determines the application of safety standards for storage, transportation, and maintenance of munitions and construction of facilities for the USAF. They are the OPR for AFMAN 91-201, *Explosives Safety Standards*, and they serve as the Air Force review authority for all explosives site plans prior to submittal to the DDESB.

Department of Defense Explosives Safety Board (DDESB)

The DDESB provides objective advice to DoD agencies regarding safety aspects of ammunition and explosives (including chemical agents) development, manufacturing, testing, handling, transportation, storage, maintenance, demilitarization, and disposal. As such, the DDESB is the executive agent for reviewing, evaluating, and approving the explosives safety aspects of all plans for siting, constructing, and modifying munitions facilities.

The DDESB maintains a list of pre-approved definitive drawings for many munitions facilities, which can facilitate the initial planning and design phase of the project. [Technical Paper \(TP\) Number 15](#), *Approved Protective Construction* (Version 1.0), provides a partial list of pre-approved definitive drawings of magazines, underground munitions storage facilities, barricades, barricaded module storage, and protective aircraft shelters. Additional pre-approved DDESB definitive design drawing information is located in [DoD 6055.9-STD](#), *DoD Ammunition and Explosives Safety Standards*.



2.4 Programming

Two primary appropriation programs exist for funding munitions facilities improvements and construction: Military Construction (MILCON) and Operations and Maintenance (O&M). The appropriate funding program is determined during the programming process based on the cost and type of work. Funding to support capital facility requirements at OCONUS locations, such as North Atlantic treaty Organization (NATO) or host nation support funding, may have unique programming requirements.

Accurate project cost estimates are essential to successful project development and execution. Typically, cost estimates are developed using parametric cost estimating tools such as the [Parametric Cost Engineering System \(PACES\)](#), as well as unit costs published in the [OSD Pricing Guide](#) or [Historical Air Force Construction Cost Handbook](#) found on the Air Force Civil Engineer Support Agency (AFCESA) web site. For more information on cost analysis, refer to [AFMAN 32-1089](#), *Air Force Military Construction and Family Housing Economic Analysis Guide* and Unified Facilities Criteria ([UFC 3-701-03](#)), *DoD Facilities Pricing Guide*.

The guidance and criteria for project funding approval varies by project type. The following sections summarize basic procedures of the typical appropriation programs.

2.4.1 Military Construction (MILCON)

MILCON applies to new construction or adaptive reuse construction activities that change the use and/or layout of an existing facility where

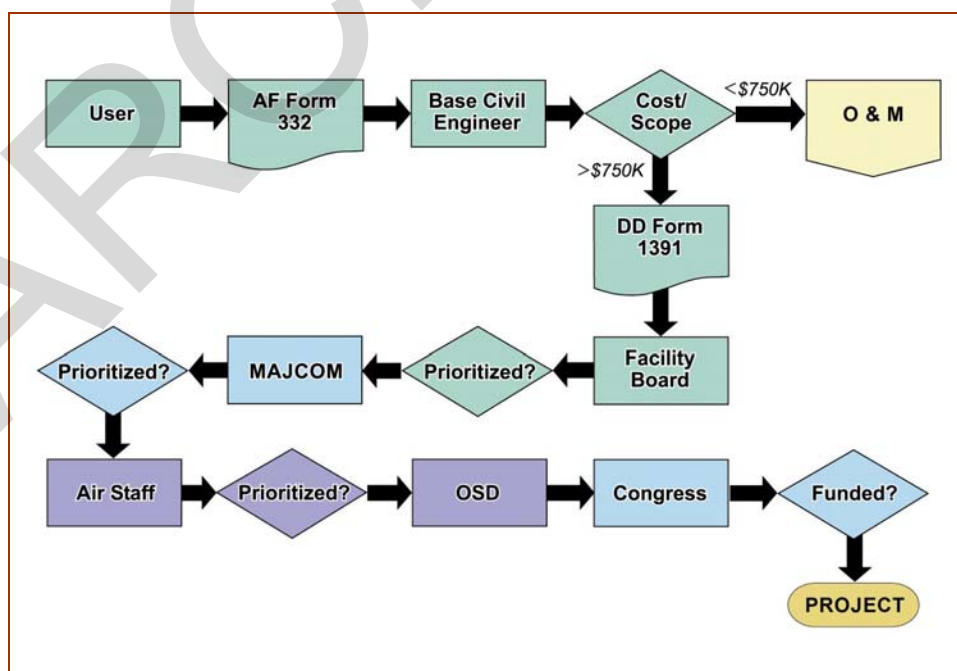

Figure 2.4
MILCON Approval Process



costs exceed \$750,000. All MILCON projects require specific planning, programming, and budgeting actions to comply with congressional requirements. [AFI 32-1021](#), *Planning and Programming Military Construction (MILCON) Projects*, provides instructions to MAJCOMs and installations on how to plan, develop, and obtain approval for MILCON projects. The following is a short summary of the MILCON approval process. This process is illustrated in Figure 2.4, “MILCON Approval Process.”

CE is responsible for all programming actions and project approvals. Project programming begins at the installation level with the development of the [DD Form 1391](#), **FY__ Military Construction Data**. The DD Form 1391 is developed by CE with input from the user and other involved agencies to identify requirements, provide a cost estimate, and justify the project.

The following items must be included with the DD Form 1391 package.

1. **Location Plan.** A map showing the location of the project and its relationship to the overall installation and surrounding areas.
2. **Site Plan.** A single line drawing or section from the base map showing the details of the immediate site.
3. **Facility Drawing.** A single line drawing of the proposed facility layout.
4. **Deficiency Detailed Data Sheet (D3 Sheet).** Details the movement of personnel and functions from sending and receiving facilities. This provides an accounting for space that is demolished, constructed, or reconfigured.
5. [AF Form 813](#), **Request for Environmental Impact Analysis.** This is a checklist that includes environmental and planning issues, and is normally completed by the Environmental Flight of CE.
6. **Certificate of Compliance.** A Certificate of Compliance must be completed by the Environmental Flight of CE and signed by the BCE and the Wing/Installation Commander certifying that all required environmental actions have been addressed.

Since the DD Form 1391 and ESP are usually completed simultaneously, a copy of the ESP submittal package should be included with the required programming documents.

2.4.2 **Operations and Maintenance (O&M) Program**

Maintenance, repairs, renovations, and minor construction projects are funded through the O&M program. Minor construction is defined as new construction, modification, or renovation that does not exceed \$750,000. O&M projects may be approved locally or at the MAJCOM,



depending on the level of authority delegated to the base from the MAJCOMs.

1. [AFI 32-1032](#), *Planning and Programming Appropriated Funded Maintenance, Repair, and Construction Projects*, provides instructions to plan and program unspecified minor construction projects and real property maintenance and repair projects.
2. **Programming O&M Projects.** The DD Form 1391 for O&M projects is an abbreviated form of the MILCON document. It consists of the front page of the DD Form 1391 that cites the project description and cost estimate.
3. **Project Description.** Same as the MILCON document.
4. **Cost Estimate.** Same as the MILCON document.
5. **Environmental Assessment.** An [AF Form 813](#) is required; however, it is not part of the DD Form 1391.

ARCHIVED





TABLE OF CONTENTS

CHAPTER 3: GENERAL DESIGN GUIDANCE

3.1	GENERAL	3-1
3.1.1	Introduction	3-1
3.1.2	Common Design Standards	3-1
3.2	SITE DESIGN	3-2
3.2.1	Pavements	3-2
3.2.2	Roads	3-2
3.2.3	Parking	3-3
3.2.4	Walkways	3-3
3.2.5	Utilities	3-3
3.2.6	Site Lighting	3-4
3.2.7	Site Signage	3-4
3.2.8	Landscaping Design	3-4
3.2.9	Grading, Soils and Hydrology	3-4
3.2.10	Site Expansion or Change of Facility Mission	3-4
3.2.11	MSA Smoking Areas	3-5
3.2.12	Electromagnetic Radiation (EMR) Hazards	3-5
3.2.13	Flammable/Combustible Materials	3-5
3.2.14	Fire Prevention/Control	3-5
3.2.15	Petroleum, Oil, and Lubricant (POL) Storage	3-6
3.3	EXTERIOR/STRUCTURAL DESIGN FOR FACILITIES	3-6
3.3.1	Exterior Materials and Methods	3-6
3.3.2	Structural Design	3-7
3.3.3	Roofs	3-7
3.3.4	Windows	3-7
3.3.5	Facility Signage	3-7
3.3.6	Lightning Protection System (LPS)	3-8
3.3.7	Grounding Systems	3-8
3.3.8	Bonding	3-8
3.3.9	Cathodic Protection (Corrosion Control)	3-8
3.4	INTERIOR DESIGN	3-9
3.4.1	Interior Surface	3-9
3.4.2	Ceilings	3-9
3.4.3	Floor Finishes	3-9
3.4.4	Walls	3-10
3.4.5	Blast Doors	3-11
3.4.6	Window Treatment	3-11
3.4.7	Lighting	3-11
3.4.8	Interior Facility Signage	3-12
3.4.9	Restrooms	3-12
3.4.10	Furniture Considerations	3-12
3.4.11	Pedestrian Egress Doors	3-12



3.5	ENVIRONMENTAL SUPPORT SYSTEMS CRITERIA	3-13
3.5.1	Mechanical Support Systems	3-13
3.5.1.1	Heating, Ventilation, and Air Conditioning (HVAC).....	3-13
3.5.1.2	Temperature Controls	3-14
3.5.1.3	Restroom Exhaust	3-14
3.5.2	Electrical Design	3-14
3.5.2.1	Lighting.....	3-14
3.5.2.2	Power Supply	3-14
3.5.2.3	Emergency Generator	3-15
3.5.2.4	Uninterrupted Power Supply (UPS).....	3-15
3.5.2.5	Lightning Protection System (LPS).....	3-15
3.5.2.6	Grounding Systems.....	3-16
3.5.2.7	Bonding.....	3-16
3.5.2.8	Surge Protection.....	3-16
3.5.3	Plumbing	3-16
3.5.4	Fire Protection and Life Safety.....	3-17
3.5.5	Energy Conservation Measures.....	3-18
3.6	TELECOMMUNICATIONS	3-19
3.7	SECURITY CRITERIA.....	3-19
3.7.1	Antiterrorism/Force Protection Criteria	3-19
3.7.2	Physical Security	3-19
3.7.2.1	Facility Site Design.....	3-20
3.7.2.2	Building Design.....	3-20
3.7.3	Communications and Electronic Security	3-20
3.7.3.1	Telecommunications Systems Design.....	3-20
3.7.3.2	Electronic Intrusion Detection Equipment (IDE) and Systems (IDS) Design.....	3-20





LIST OF FIGURES

CHAPTER 3: GENERAL DESIGN GUIDANCE

FIGURE 3.1	Concrete Parking Apron Outside Powered Trailer Maintenance Facility - Barksdale AFB, LA	3-2
FIGURE 3.2	POV Parking - McChord AFB, WA	3-3
FIGURE 3.3	Explosives/Hazard Symbol Signage - McChord AFB, WA	3-4
FIGURE 3.4	Landscape at Weapons Release Systems Shop - Cannon AFB, NM	3-4
FIGURE 3.5	Exterior Elevations Employ Non-combustible Materials - Munitions Maintenance Facility - Cannon AFB, NM	3-5
FIGURE 3.6	Steel Constructed K-span - Above Ground Magazine - Cannon AFB, NM	3-6
FIGURE 3.7	Frangible Roof Design - Multi-cubicle Magazine Storage Facility - Langley AFB, VA	3-7
FIGURE 3.8	Facility Signage - McChord AFB, WA	3-7
FIGURE 3.9	LPS (Catenary System) - Integrated Maintenance Facility - Barksdale AFB, LA	3-8
FIGURE 3.10	Grounding System Inside Flightline Holding Facility - McChord AFB, WA	3-8
FIGURE 3.11	Interior Wall Finish in Munitions Administration Facility - Barksdale AFB, LA	3-9
FIGURE 3.12	Chemical Resistant Urethane on a Concrete Floor - Munitions Loading Crew Training Facility - Luke AFB, AZ	3-9
FIGURE 3.13	Interior Lighting in Weapons and Release Systems Shop - Langley AFB, VA	3-11
FIGURE 3.14	HVAC System for Surveillance and Inspection Shop - Langley AFB, VA	3-13
FIGURE 3.15	Explosive-proof Lighting in Flight Line Holding Facility - McChord AFB, WA	3-15
FIGURE 3.16	Grounding System inside Flight Line Holding Facility - McChord AFB, WA	3-16
FIGURE 3.17	Security Barriers Protecting Entrance to Munitions Storage Area - Cannon AFB, NM	3-19
FIGURE 3.18	Security Lighting on Segregated Magazine - Langley AFB, VA	3-19
FIGURE 3.19	High Security Hasp on Storage Igloo - Luke AFB, AZ	3-20



ARCHIVED



3.1 General

COMMON FEATURES

Type of Construction

- All facilities must be constructed of non-combustible materials (concrete or steel) per [UFC 3-600-01](#)

Mechanical Requirements

- Heated and air conditioned classroom and administration areas
- Comply with the applicable mechanical code and American Society of Heating, Refrigerating, and Air-Conditioning Engineers ([ASHRAE](#)) guidelines
- Additional mechanical requirements can be found in [MIL HDBK 1190](#), *Facility Planning and Design Guide*

Bonding, Grounding, Surge, and Lightning Protection

- Install and maintain systems according to [AFI 32-1065](#), [MIL HDBK 419](#), [NFPA 780](#), [DoD 6055.9-STD](#), and [AFMAN 91-201](#)

3.1.1 Introduction

This chapter provides an overview of the standards that apply to site and facility design, facility infrastructure and support systems, and security elements common to the majority of munitions maintenance, storage, transportation, and administrative facilities. These standards are addressed in the following sections:

- 3.2 Site Design
- 3.3 Exterior Design
- 3.4 Interior Design
- 3.5 Environmental Support Systems
- 3.6 Telecommunications
- 3.7 Security Criteria

3.1.2 Common Design Standards

The following design standards apply to most munitions facilities:

1. Facilities must comply with current Air Force, Department of Defense (DoD), and industry (e.g., National Institute of Building Sciences, National Fire Protection Association, National Electric Code, etc.) construction and explosives safety standards.
2. The facility design should be simple and logical and satisfy the requirements of the project, site, and functional user.
3. The construction of the facility should be the most cost effective without compromising the architectural and engineering aspects of the facility such as flexibility, function, and character.
4. The facility must comply with all aspects of the Uniform Federal Accessibility Standard ([UFAS](#)) and Americans with Disabilities Act Accessibility Guidelines ([ADAAG](#)).
5. Structural design should be reviewed in accordance with seismic design criteria (see Section 3.3.2, "Site Design").
6. Local climate conditions should be evaluated to determine the effects of the environment on a specific type of facility (e.g., humidity control, air filtration, heating/cooling, energy consumption, insulation, degradation of building materials, etc.). Refer to [AFH 32-1163](#), *Engineering Weather Data*, for additional guidance.



7. The USAF requires that projects must be capable of achieving [Leadership in Energy and Environmental Design \(LEED\)](#) minimum certification as required by the [U.S. Green Building Council](#) (USGBC).
8. [USAF Project Managers' Guide for Design and Construction](#) provides guidance on the standards for Military Construction (MILCON) projects. Major Command (MAJCOM) architectural standards and Air Force architectural standards apply to both MILCON and Operations and Maintenance (O&M) projects.

3.2 Site Design

Site design locates the facility footprint within a given parcel of land, incorporates circulation and parking, identifies infrastructure locations and landscaping requirements. Refer to [UFC 3-210-01A](#), *Design: Area Planning, Site Planning, and Design*, for further information. The site design process should ensure the site meets mission requirements, addresses potential site constraints, and identifies expansion possibilities to accommodate future missions. It should address surrounding structures, natural resources (e.g., topography, drainage, and soil conditions), and climate. The following factors should be considered when planning a facility site.



Figure 3.1
Concrete Parking Apron
outside Powered Trailer
Maintenance Facility –
Barksdale AFB, LA

3.2.1 Pavements

Design pavements to meet the functional requirements of the munitions operations. Ensure the roadbed is able to withstand the gross weight of vehicle and support equipment traffic. Design grade of apron pavements to ensure proper drainage and appropriate slope for safe vehicle access. In colder climates, consider loading and unloading operations under icy conditions. Refer to [UFC 3-230-17FA](#), *Design: Drainage for Areas Other than Airfields*, for additional information. Consult base civil engineer (CE) squadron for grade design.

3.2.2 Roads

Roadways within the munitions storage area (MSA) should be designed to withstand the weight of vehicles and their loads. Designs of pavements are a site-specific consideration. Consult the base CE squadron for local guidance. Refer to [UFC 3-250-01FA](#), *Design: Pavement Design for Roads, Streets, Walks, and Open Storage Areas*, for further information. Roads must also accommodate the turning radii and maneuvering requirements of the largest piece of munitions materiel-handling equipment (MMHE) assigned to the installation. Roads must have safe horizontal and vertical curves. Road system access to groups of explosives storage sites should be planned to avoid dead ends and permit emergency ingress/egress. Provide primary and alternate all-weather roads to the MSA for explosives movements. These explosives delivery routes should avoid heavily populated areas and key mission-critical facilities.





Figure 3.2
POV Parking –
McChord AFB, WA

3.2.3 Parking

Provide enough parking spaces to support the mission of the facility. Refer to [AFH 32-1084](#), *Facility Requirements* for calculating parking area square footage for privately owned vehicles (POVs) and passenger-type government owned vehicles (GOVs). Special allowances are made for oversized vehicles and support equipment. Quantity-Distance (Q-D) guidance in [AFMAN 91-201](#), *Explosive Safety Standards*, provide details for siting parking areas. Since POVs are not normally permitted in the MSA, the design of parking areas inside the MSA should be for GOVs and munitions handling support equipment only. When possible, trash dumpsters and recycling bins should be located adjacent to the parking area to minimize paved surfaces. Refer to [UFC 3-230-18FA](#), *Design: General Provisions and Geometric Design for Roads, Streets, Walks, and Open Storage Areas*, for further information.

Accommodations for the physically challenged should be provided in accordance with [UFAS](#) and [ADAAG](#) criteria where POV parking is required.

3.2.4 Walkways

Design and build hard-surfaced walkways that complement the natural flow of pedestrian traffic to connect parking, work areas, and associated buildings within the site. The walkways to facility entrances should be a minimum 4 feet (ft) (1.2 meters (m)) wide and increase in increments of 2 ft (0.6 m) to meet local requirements. See [AFH 32-1084](#). Where there is a significant change in the grade (greater than 5%), provide both steps and ramps. If required, provide sidewalk access for the physically handicapped according to [UFAS](#) and [ADAAG](#) criteria. Provide curb ramps if curbs are installed.

3.2.5 Utilities

Ascertain the availability and capacity of the existing utility systems including both the primary trunk lines and laterals to serve the facility/site. Ensure facility siting accommodates utility operations and maintenance, and that utility capacities can accommodate foreseeable capital improvements. Depending on the facility, factors to consider include water (e.g., line capacity and pressure), electricity (e.g., transformer and line capacity, service type, phasing, and purity), natural gas (e.g., delivery pressure and line capacity), wastewater (e.g., closest main, pump and line capacity), storm water drainage (e.g., detention pond capacity and discharge locations), and communications (e.g., capacity, service type). Consult the CE utilities manager and the Communications Squadron for information about capacities and connectivity of the required utilities.



3.2.6 Site Lighting

Depending on the type of facility, the security threat assessment, and the facility's intended use, install high intensity discharge (HID) security lighting. Follow the recommendations of the [Illuminating Engineering Society's \(IES\) Illuminance Selection Procedures](#) to establish appropriate foot-candle (meter-candle) illumination levels for the site. Photosensitive sensors should be used to help achieve energy-efficiency. Security Forces shall be consulted on the lighting plan to ensure it adequately accommodates security surveillance.

3.2.7 Site Signage

Site signage should comply with the installation standards and [UFC 3-120-1, Air Force Sign Standard](#). This document contains guidelines for layout, construction, and placement of signs at the site. Additional signage requirements exist in [AFMAN 91-201](#).

3.2.8 Landscaping Design

Consult the [USAF Landscape Design Guide](#) when incorporating a landscape scheme. Use low maintenance, drought tolerant, native plants. The use of regionally appropriate landscaping techniques is extremely important on igloo and barricade walls to minimize the potential erosion of these sloped areas, thereby preserving their safety qualities in the event of an explosion. Avoid creating terrorist concealment opportunities in the landscape design. Refer to [USAF Master Landscape Construction Specifications](#).

3.2.9 Grading, Soils, and Hydrology

Natural environmental factors such as flood potential, soils, shrink-swell, topography, slope, etc should be considered during the design process. A grading plan that maintains a natural drainage pattern for the site and directs site flows towards the existing drainage system in the area should be prepared. Provide an appropriate surface drainage system to prevent erosion and flooding. Where required, provide for velocity reduction, on-site water detention, and erosion prevention.

3.2.10 Site Expansion or Change of Facility Mission

Flexibility should be built into the site design to allow for future expansion of the facility due to mission changes. A future change in facility mission may require a change of the CE Real Property Category Code as well as create Q-D violations. A new explosives site plan (ESP) may be required.



Figure 3.3
Explosives/Hazard Symbol
Signage –
McChord AFB, WA



Figure 3.4
Landscape at Weapons and
Release Systems Shop –
Cannon AFB, NM



3.2.11 MSA Smoking Areas

If the smoking area is within the MSA, follow the guidance contained in [AFMAN 91-201](#). The smoking area should be sited to comply with explosives and fire safety requirements, with a minimum separation distance of 50 ft (15.2 m) from an explosives location.

3.2.12 Electromagnetic Radiation (EMR) Hazards

Contact the installation's Weapons Safety Manager (WSM), base communication squadron, and radiation safety officer to pinpoint the EMR emitter sources around the planned site (e.g., utility lines, radio/communication antennas, etc.) and determine their impact on electro-explosive devices. Consider the sensitivity of the munitions, packaging, configuration of the leads, and the power density of the EMR source. Calculate the factors and site the facility according to the safe separation distance guidelines in [DoD 6055.9-STD](#), *DoD Ammunition and Explosives Safety Standards* and [AFMAN 91-201](#). EMR hazards should also be considered when determining explosives movement routes.

3.2.13 Flammable/Combustible Materials



Figure 3.5
Exterior Elevations Employ
Non-combustible Materials –
Munitions Maintenance
Facility –
Cannon AFB, NM

If the projected munitions facility requires a separate flammable or combustible materials storage site, locate the site at least 50 ft (15.2 m) away from the planned facility. Contact the Base Ground Safety representative for further assistance in determining flammable or combustible storage facility requirements.

Do not use combustible materials in construction of the exterior of facilities within the MSA.

Additional flammable or combustible storage information is contained in [AFOSH 91-501](#), *Air Force Consolidated Occupational Safety Standard*, [National Fire Protection Agency \(NFPA\) 30](#), *Flammable and Combustible Liquid Code*, and [Technical Order \(TO\) 42A2-1-4](#), *Storage Control of Organic Coating Materials (Paints and Allied Materials)*.

3.2.14 Fire Prevention/Control

Maintain a 50 ft (15.2-m) firebreak around the explosives facility when environmental and security factors allow. Design firebreaks to slow the spread of fire if grasses or ground cover are used for erosion control on (i.e., igloos) or near facilities. Ensure vegetation is maintained to reduce fire potential. An adequate supply of water and pressure should be available to suppress fires in accordance with [AFMAN 91-201](#).



3.2.15

Petroleum, Oil, and Lubricant (POL) Storage

If the planned munitions facility requires POL support, such as fuel tanks for filling vehicles and support equipment, contact the base WSM to determine the storage tank location based on the facility mission requirements. The proper separation between the facility and the storage tank must be maintained in accordance with [DoD 6055.9-STD](#), [AFMAN 91-201](#), and [NFPA 30](#). Storage tanks located above ground must comply with local, state, and federal environmental requirements and [NFPA 30](#). They must also comply with [AFI 32-7044](#), *Storage Tank Compliance*.

3.3 Exterior/Structural Design for Facilities

The exterior design should reflect the functional requirements of the mission planned for the facility and base-specific requirements for materials and structural design.

Unique mission requirements may need special architectural attention (e.g., apron load strength, lighting requirements for night operations, security enhancements, door size, etc.). Existing pre-approved Department of Defense Explosives Safety Board (DDESB) design drawings (listed in Technical Paper Number 15, *Approved Protective Construction*) should be reviewed for their appropriate application to similar facility functional requirements. Specific design and construction criteria for the facility requirements must be established before the project concept phase to provide the basic framework for the design.

The Air Force Center for Environmental Excellence (AFCEE) has provided an excellent tool for CE and contractors to develop architectural compatibility for the project. Additional information on this tool is available in the [Air Force Architectural Compatibility Guide](#) located at the AFCEE web site.

3.3.1

Exterior Materials and Methods

While certain building materials are required for safety, the base architectural standards will provide guidance on the type of exterior materials and local methods of construction. Building materials and finishes that are functional, durable, and easy to maintain should be selected. All facilities shall be constructed of non-combustible materials per [AFMAN 91-201](#).

Consider recycled materials for use in construction using the Environmental Protection Agency (EPA) guidelines. The recycle guideline list changes every other year when the EPA adds new items. For the current list of recycle items, go the [EPA](#) web site. Refer to [AFI 32-7080](#), *Pollution Prevention Program*, and the [Guide to Green Purchasing](#) for more information on using recycled materials.



Figure 3.6
Steel-constructed K-span –
Above Ground Magazine –
Cannon AFB, NM



Seismic Criteria References

[Army TI 809-4](#), *Seismic Design for Buildings*

[AFMAN 88-3, Chapter 13 \(Army TM 5-809-10\)](#), *Seismic Design for Buildings*

[ETL 00-5](#), *Seismic Design for Buildings and Other Structures*

[AFMAN 32-1050\(I\)](#), *Seismic Design Guidelines for Upgrading Existing Buildings*

[TM 5-1300/AFR 88-22](#), *Structures to Resist the Effect of Accidental Explosions*

[UFC 1-200-01](#), *Design: General Building Requirements*



Figure 3.7
Frangible Roof Design – Multi-cubicle Magazine Storage Facility - Langley AFB, VA



Figure 3.8
Facility Signage – McChord AFB, WA

3.3.2 Structural Design

Consider a variety of systems (e.g., steel frame, reinforced concrete, etc.) for the project and select the system that satisfies the facility's current requirement, provides for future expansion and flexibility, and fulfills architectural compatibility standards.

The design and construction methods must be suitable for a permanent facility conform to current DoD, Air Force, and industry explosives safety standards; and must protect against seismic events and local weather conditions at the site. (See Seismic Criteria textbox in margin.) Use DDESB pre-approved facility designs whenever possible. "Best in class" facility designs are provided in Chapter 4, "Design Standards."

If required, a seismic evaluation of the site will be performed. Use DDESB pre-approved facility designs and structural systems whenever possible. A comprehensive submittal to DDESB is required for new facility designs. For more information on Structural Design, refer to [UFC 3-310-01](#), *Design: Load Assumptions for Buildings* and [UFC 3-340-01](#), *Design: Design and Analysis of Hardened Structures to Conventional Weapons Effects*.

3.3.3 Roofs

Frangible roof structures should be incorporated to vent an internal explosion upward and minimize large fragments. Refer to [TM 5-1300/AFR 88-22](#) for details on proper construction of a munitions facility. Roof design should also consider local weather conditions (e.g., snow loading, wind, etc.). Refer to [UFC 3-190-04FA](#), *Design: Roofing and Waterproofing*.

3.3.4 Windows

Windows in facilities within the explosives clear zone should not face other buildings where explosives are manufactured, processed, stored, or handled. Windows in facilities within the explosives clear zone must have shard-resistant protection (e.g., laminated glass, mylar film, explosive-proof glass, blast curtains, etc.). Additionally, windows must comply with Anti-Terrorism/Force Protection (AT/FP) requirements if the facility is considered inhabited (11 or more personnel routinely working or present in the facility). AT/FP protection criteria can be found in the [U.S. Air Force Installation Protection Guide](#).

3.3.5 Facility Signage

Facility signage (e.g., building number and identification, fire/hazard symbols) must follow the base design standards and the guidelines contained in [UFC 3-120](#) and [AFMAN 91-201](#).



3.3.6 Lightning Protection System (LPS)

A LPS is required for all munitions facilities. The LPS will be designed to intercept lightning at a 100 ft (30 m) or less striking distance. For most munitions facilities, the design drawing provides specific requirements for installing LPS. Refer to [DoD 6055.9-STD](#), [AFMAN 91-201](#) and [NFPA 780](#), *Standards for the Installation of Lightning Protection Systems*, for additional LPS protection information.

In overseas locations, refer to the Host Nation Program Management Office (PMO) liaison for LPS requirements. Many host nation requirements exceed U.S. design criteria. In this case, the more stringent requirements shall be followed.

3.3.7 Grounding Systems

Based on the facility's mission requirements, install a system that will eliminate or reduce the hazards of static electricity. The system must meet a resistance of 25 ohms or less. The system may be tied into the facility's LPS or structural members for all facilities handling, processing, or storing explosives. [AFI 32-1065](#), *Grounding Systems*, and [AFMAN 91-201](#) for more information on grounding systems requirements.

3.3.8 Bonding

To prevent lightning penetration into the facility, bond all metallic objects entering the structure to the LPS. Resistance to any metal object bonded to the LPS will not exceed one ohm. Material used for the bond must be compatible with the metallic mass and down conductor to prevent corrosion. Bond the LPS to all grounding systems at the counterpoise or ground rod outside the facility.

3.3.9 Cathodic Protection (Corrosion Control)

Cathodic protection may be required on facilities in areas where galvanic action occurs due to the soil composition. Ferrous materials should be protected from corrosion by providing coating, wrapping, cathodic protection, or isolation of dissimilar materials. For additional corrosion control guidance and related web links, refer to the Air Force Civil Engineering Support Agency (AFCESA) [Corrosion Control Program](#) and [UFC 3-570-02N](#), *Design: Electrical Engineering Cathodic Protection*.



Figure 3.9
LPS (Catenary System) –
Integrated Maintenance
Facility - Barksdale AFB, LA



Figure 3.10
Grounding System Inside
Flight Line Holding Facility -
McChord AFB, WA

3.4 Interior Design



Figure 3.11
Interior Wall Finish in
Munitions Administration
Facility -
Barksdale AFB, LA

The interior features of the facility should be integrated with the architectural design and should meet future mission and functional user requirements. If applicable, munitions facilities must meet the requirements of [UFAS](#) and [ADAAG](#) including accessibility to and from work spaces, accessibility inside restrooms, access to the facility, and fire alarm notification in the form of audio and visual strobes in work spaces, restrooms, and storage rooms. The following elements should be reviewed when designing the interior of a munitions facility. Refer to the [Air Force Interior Design Guidelines](#) for additional guidance on interior design standards and criteria.

3.4.1 Interior Surface

General guidelines for interior surfaces are as follows.

1. Non-combustible materials should be used as much as possible for interior surfaces in accordance with [UFC 3-600-01, Design: Fire Protection Engineering for Facilities](#), [DoD 6055.9-STD](#), and [AFMAN 91-201](#). If it is necessary to use combustible material in the interior of a munitions facility, treat or cover the surfaces with a fire-retardant material as recommended by the Base Fire Marshall.
2. Interior surfaces (ceilings, walls and floors) where explosives are handled, inspected, maintained, or stored must be smooth and free of cracks and crevices.
3. Provide a pleasing color scheme in inhabited areas using accents or materials that are easily maintained or changed (e.g., accent tiles, trim and/or door paint, signage).

3.4.2 Ceilings

The ceiling design must take into account the facility's security, environmental, and maintenance requirements.

3.4.3 Floor Finishes

The following floor treatments should be considered when designing a munitions facility.

1. A concrete subfloor should be used in locations where explosives are handled, maintained, inspected, or stored.
2. Where finished floors are required (application of a coating or other finishing material to the concrete floor), provide static free surfaces to mitigate the potential of a buildup of static electricity that could cause a fire or inadvertently initiate an electro-explosives device (EED). Non-sparking floors must be smooth



Figure 3.12
Chemical-resistant
Urethane on a Concrete
Floor – Munitions Loading
Crew Training Facility -
Luke AFB, AZ



and free of cracks and wrinkles. Non-asbestos resilient floor tile should be considered as a primary floor finish for high foot traffic areas such as entrances, corridors, and hallways.

3. Carpeted floor finishes should be non-static and will only be used in special areas where deemed appropriate (e.g., offices, training classrooms, munitions control rooms, administration areas, etc.) and where additional acoustical treatment is a critical requirement. For the latest guidance on carpets, refer to *Engineering Technical Letter 00-6* ([ETL 00-6](#)), *Air Force Carpet Standards*, and the [USAF Interior Design Guidelines](#).

3.4.4 Walls

The following guidance should be considered in wall design.

1. Exposed concrete walls are acceptable in unoccupied areas, operating locations, storage facilities, or as substantial dividing walls. They are not acceptable as an interior wall finish in occupied areas such as administrative, training, and office locations.
2. A durable, textured finish should be provided in inhabited areas.
3. Use a vinyl covering or similar material on walls that are susceptible to mold and moisture intrusion due to climate, location, or operations in the room(s).
4. When paint is used, apply semi-gloss or low sheen paint to the walls. Only apply high gloss paint for trim, safety markings, restrooms, or similar application.
5. Ceiling paint should maximize reflectivity to enhance interior lighting.
6. Walls should be designed to prevent the spread of fire from one area to another in the facility. Firewalls should be constructed according to [UFC 3-600-01](#), *Fire Protection Engineering for Facilities* and [AFMAN 91-201](#). Openings in the firewall should comply with [NFPA 80](#), *Standards for Fire Doors and Windows*.
7. When necessary to conduct more than one explosives operation within a facility, the operations must be arranged to provide a minimum of intraline (IL) protection by distance or equivalent protection. The goal of IL distance is to prevent propagation of other explosives within the facility in the event of an inadvertent explosives accident. If separation distance is not possible, substantial dividing walls of 12 in (30 mm) reinforced concrete walls rated at 2,500 pounds per square inch (psig) (17,170 kilo



Additional Lighting References

[Air Force Interior Design Guidelines](#). Aids in planning facility lighting requirements

[DoD 6055.9-STD](#) and [AFMAN 91-201](#). Describe explosives safety standards and some potential special lighting requirements

[National Electric Code](#). Contains sources to obtain general information on wiring and lighting needs

[Illuminating Engineering Society](#). Allows users to purchase publications relating to lighting needs

[NFPA 101, Life Safety Code](#). Standards to calculate the project lighting requirements



Figure 3.13
Interior Lighting in Weapons and Release Systems Shop - Langley AFB, VA

pascals (kPa)) between work bays may provide the required level of protection. Bear in mind properly applied distances and substantial dividing walls may not prevent personnel injury in the event of an explosives mishap. Refer to [DoD 6055.9-STD](#), [AFMAN 91-201](#), [TM 5-1300/AFR 88-22](#), and your servicing MAJCOM to obtain guidance in determining the protective wall thickness or distance between operations to meet IL distance criteria and the proper stand-off distance for conducting concurrent operations.

3.4.5 Blast Doors

Blast doors function to separate explosives work or storage spaces. The doors must only be used where high explosives are involved and protection of personnel and high-value, non-explosives equipment, or preventing propagation, is desired. Blast doors are not installed as a matter of convenience in the facility but are used for operational necessity. Refer to [DoD 6055.9-STD](#) and [TM 5-1300/AFR 88-22](#) to provide additional details for calculating the design factors needed for blast doors.

3.4.6 Window Treatment

Window tinting functions to reduce the glare and solar radiation penetration into the facility. These treatments should be provided in climates where the sun generates substantial glare or heat. Blackout-lined drapes or blackout blinds/shades for windows should be used in training rooms. If the facility is located within the explosives clear zone, the windows may also need to have shard-resistant properties to protect personnel from flying glass caused by the effects of overpressure from an explosive force. See Section 3.3.4, “Windows” for further information about window treatment.

3.4.7 Lighting

Lighting levels should be designed to accommodate the functions performed; higher lighting levels are required for detailed work and lower levels are required for general areas. The task lighting, special task lighting, and general lighting needs of the facility determine the maximum illumination (as measured in foot candles) required within the facility. The foot-candles needed in a munitions storage location may be much less than what is required in an operating location where intricate assembly work is being performed.

Normally, [Underwriters Laboratories \(UL\)](#)-approved lighting will suffice for the majority of facilities. However, explosion-proof lighting will be required if Class I explosive vapors or Class II explosive dust will be present at the operating or storage location. The functional user should be consulted for additional project lighting requirements. Refer to the “*Additional Lighting Resources*” textbox in the margin for additional guidance.



The base bioenvironmental function can assist in determining the proper illumination requirements, or quantify existing deficiencies by performing lighting surveys.

3.4.8 Interior Facility Signage

Interior signs include, but are not limited to, exit signs, directional arrows, security warnings, fire fighting equipment location, etc. All interior signage must comply with the installation signage program and [UFC 3-120-1](#), [AFMAN 91-201](#), [UFAS](#), and [ADAAG](#), as applicable.

3.4.9 Restrooms

The occupancy level for the planned facility determines the required number and type of restroom facilities. Small facilities may have one unisex restroom; large facilities, or facilities with a high occupant level, should have separate restroom facilities. One shower and a locker room for each gender should be provided in facilities where the facility is utilized 24 hours per day or where the work environment requires such facilities. Lavatories should be designed with full-width counter tops that are wall-secured on three sides or sinks mounted in cabinet structures. All mirrors shall be directly mounted to the wall.

The floor should be covered with either non-skid ceramic or porcelain paver tiles with epoxy grout. The walls should be non-porous ceramic wall tiles or painted gypsum wallboard from the floor to the ceiling with a 4 in (98 mm) splashguard. Proper lighting, ventilation, and electrical outlets should comply with current industry standards.

3.4.10 Furniture Considerations

Consult the functional user to determine furniture requirements. Refer to the [Air Force Interior Design Guidelines](#) for assistance in planning the facility furniture layout. “Closed-wall or cubicle” offices should measure at least 10 ft x 10 ft (3 m x 3 m) in order to arrange furniture in a functional manner.

3.4.11 Pedestrian Egress Doors

Provide at least two exits out of each operating room or building containing explosives, with the egress routes free of obstructions. Doors should be panel- or flush-type construction, not less than 36 in wide (0.9 m) by 80 in (2 m) high, and should open outward. If vision panels are a necessary component of the door, shard-resistant glass should be used. Shatter-resistant glazing with acrylic plastic or equivalent material is recommended. The window frame or sash must maintain sufficient strength to retain the panel in the door in the event of an explosion. Door closing mechanisms should include dead bolt panic hardware that cannot be opened from the outside. Refer to the [American National Standards Institute \(ANSI\) Safety Code A156.3](#), *Building Exits*, [NFPA](#), and





Figure 3.14
HVAC System - Surveillance
and Inspection Shop -
Langley AFB, VA

Additional Mechanical Support References

[NFPA 70](#), *National
Electric Code*

[NFPA 101](#), *Life Safety
Code*

[NFPA 780](#), *Standards for
the Installation of
Lightning Protection
Systems*

[AFJMAN 32-1083](#),
Electrical Interior Code

[AFI 32-1065](#), *Grounding
Systems*

[DoD 6055.9-STD](#) and
[AFMAN 91-201](#), *DoD and
Air Force Explosives
Safety Standards*

[MIL HDBK 419A](#),
*Grounding, Bonding, and
Shielding for Electronic
Equipment and Facilities*

[AFCESA Electrical
Program](#)

[ETL 90-06](#), *Electrical
System Grounding, Static
Grounding and Lightning*

applicable local and/or uniform building codes to construct emergency exits and fire escapes. See Section 3.5.4, “Fire Protection and Life Safety” for additional information on egress door locations.

3.5 Environmental Support Systems

There are several key facility environmental support services (i.e., mechanical, electrical, plumbing, fire protection, and energy conservation controls) that interact with each other. The layout of the requirements must be integrated to produce a total environmental services design. Both mission efficiencies and utility effectiveness must be taken into account. The correlation of the design for each environmental service should be done during all stages of the facility design. This becomes important when selecting the proper environmental system to support the intended facility mission requirements based on user input for the project.

The items contained in the following paragraphs will provide a general list of environmental support systems that must be reviewed to ensure all design components have been considered for the project. Specific direction related to unique environmental system support requirements is in Chapter 4, “Design Standards” of this guide.

3.5.1 Mechanical Support Systems

3.5.1.1 Heating, Ventilation, and Air Conditioning (HVAC)

The **HVAC** design must comply with the guidelines in [MIL HDBK 1190](#), *Facility Planning and Design Guide*. Refer to [ETL 94-4](#), *Energy Usage Criteria for Facilities in the Military Construction Program*.

The system must comply with [ETL 01-1](#), *Reliability and Maintainability (R&M) Design Checklist*, criteria, as HVAC maintenance is critical to the quality of life of the occupants of the facility.

HVAC units should be located within a designated mechanical room/closet whenever feasible to ensure that filters, controls, drain pans, condensate piping, control valves, and coils are easily accessible for servicing and cleaning. For large HVAC systems, roof mounting or ground-level units may be used if screened. Condensate piping should be provided, equipped with traps and threaded clean outs at the unit. The design must include minimum clearances for maintenance. The mechanical room/closet must have a locking door that opens directly to the exterior for access by base CE.

A central ventilation system should supply conditioned air to each office space and munitions work bay when needed. If the possibility fumes may reenter the system and contaminate the air in other parts of the



building, separate ventilation systems may be required. The system should meet conditioned air requirements outlined in [ASHRAE Standard 62](#), *Ventilation for Acceptable Indoor Air Quality*.

3.5.1.2 Temperature Controls

The HVAC equipment should be controlled via a direct digital control (DDC) system. Guidance is provided in [ETL 86-16](#), *Direct Digital Control of Heating, Ventilation, and Air Conditioning Systems*, for planning DDC systems.

3.5.1.3 Restroom Exhaust

The restrooms should be equipped with an individual or central exhaust system, directly vented, with a switched exhaust fan.

3.5.2 Electrical Design

The electrical design should be based on maximum occupancy for the facility and the projected operational loads. The design should include electrical distribution equipment, data fax ports, fire detection and annunciation, emergency and egress lighting, interior and exterior lighting, and receptacles and grounding plans. Facility designs must include all electrical equipment, items, device controls, and loads. Special power requirements may be needed as listed in Chapter 4, “Design Standards” for test equipment (e.g., 400 hertz (Hz), 3-Phase, etc.). A high-quality converter is required to ensure facilities have a clean, non-fluctuating, power source.

Cables or conduits must be placed underground through shielded cables or in metallic conduits for at least 50 ft (15.2 m) before entering an explosives facility (except licensed explosives facilities such as the weapons and release shop and loading crew training facility).

Refer to [DoD 6055.9-STD](#), [AFMAN 91-201](#), and [MIL HDBK 419A](#), *Grounding, Bonding, and Shielding for Electronic Equipment and Facilities*, for grounding, bonding, and surge protection guidance.

3.5.2.1 Lighting

Interior lighting that meets Energy Star program standards should be used whenever feasible. Refer to the [Energy Star](#) web site for a product list. Light fixture installations should comply with the criteria in [UFC 3-600-01](#) and [NFPA 70](#). Use [NFPA 70](#), [NFPA 101](#), and the [IES Lighting Handbook](#) for lighting calculations. Normally, [UL](#)-approved lighting will suffice for the majority of facilities. However, explosion-proof lighting will be required if Class I explosive vapors or Class II explosive dust will be present at the operating location.

3.5.2.2 Power Supply

The power supply should be designed to accommodate 130 percent of the load planned for the facility. Continental United States (CONUS) and, wherever possible, overseas locations, require standard 60-Hz

Additional Electrical References

[NFPA 70](#), *National Electric Code*

[NFPA 101](#), *Life Safety Code*

[NFPA 780](#), *Standards for the Installation of Lightning Protection Systems*

[AFJMAN 32-1083](#), *Electrical Interior Code*

[AFI 32-1065](#), *Grounding Systems*

[DoD 6055.9-STD](#) and [AFMAN 91-201](#), DoD and Air Force Explosives Safety Standards

[MIL HDBK 419A](#), *Grounding, Bonding, and Shielding for Electronic Equipment and Facilities*

[AFCEA Electrical Program](#)

[ETL 90-06](#), *Electrical System Grounding, Static Grounding and Lightning Protection*



frequency for all possible loads. This eliminates the use of individual power converters. If 60 Hz power is not available at overseas locations, comply with local code requirements and provide 220 volts alternating current (VAC)/230 VAC duplex power outlets, in addition to 115 VAC. For unique power supply requirements, refer to Chapter 4, “Design Standards,” of this guide. **Designers must always verify local electrical conditions at OCONUS locations before starting the electrical design phase of the project.**

3.5.2.3 Emergency Generator

Administrative and munitions operating facilities require emergency power. The rationale for this requirement is based upon the need to preserve critical information on accountability and munitions testing systems. For those munitions facilities that require emergency power, provide a diesel generator in accordance with (IAW) [AFI 32-1062](#), *Electrical Power Plants and Generators*, and [AFI 32-1063](#), *Electrical Power Systems*.

Emergency generators should provide a constant power source for critical services (e.g., computers, radios, test equipment, etc.), life safety, and intrusion detection systems. The [Defense Transportation Regulation, Chapter 205](#), requires the generator and fuel source supplying the Vehicle Secure Parking Area be secured and locked. Generator fuel storage must comply with Q-D criteria in [DoD 6055.9-STD](#) and [AFMAN 91-201](#) explosives safety standards.

3.5.2.4 Uninterrupted Power Supply (UPS)

If authorized by [AFH 32-1084](#) or other regulation or technical order, a UPS should be installed in conjunction with the facility power system(s). The UPS should supply a minimum of 15-30 minutes of backup power to supported equipment to permit completion of tasks or proper shutdown of equipment.

3.5.2.5 Lightning Protection System (LPS)

An LPS is required for munitions facilities (e.g., operating locations, storage magazines, loading crew training facilities, weapons and release systems shops, critical administrative facilities, etc.). An LPS should be designed to intercept lightning at a 100 ft (30.5 m) or less striking distance from munitions or other critical resources. Munitions facilities design drawings must specify LPS requirements. Refer to [DoD 6055.9-STD](#), [AFMAN 91-201](#), the [Lightning Protection Institute](#) web site, [ETL 90-06](#), *Electrical System Grounding, Static Grounding, and Lightning Protection*, and [NFPA 780](#) for additional LPS protection information. The LPS design must be submitted to the DDESB with the facility design for approval prior to construction per [AFMAN 91-201](#).

In CONUS, [AFMAN 91-201](#) and [NFPA 780](#) requirements will be used as the minimum acceptable standard for LPS. Many host nation requirements exceed United States design criteria. In overseas locations,



Figure 3.15
Explosive-proof Lighting in
Flight Line Holding Facility -
McChord AFB, WA



refer to the Host Nation Program Management Office (PMO) liaison for LPS requirements.

3.5.2.6 Grounding Systems

If authorized by [AFMAN 91-201](#) or other regulation or technical order, a grounding system must be installed which meets a resistance of 25 ohms or less IAW [AFI 32-1065](#). The grounding system may be connected to the LPS or structural members in facilities handling, processing, or storing explosives. The grounding system design must be submitted with the facility design to the DDESB for approval prior to construction per [AFMAN 91-201](#).



Figure 3.16
Grounding System Inside
Flight Line Holding Facility -
McChord AFB, WA

3.5.2.7 Bonding

To prevent lightning discharges from penetrating the facility, all metallic objects entering the structure should be bonded to the LPS, with resistance readings not to exceed one ohm. The bonding material should be compatible with the metallic mass and down conductor to prevent corrosion. The LPS should be bonded to all grounding systems at the counterpoise or ground rod outside the facility.

3.5.2.8 Surge Protection

Surge protection should be installed on external power, communication, intrusion detection system, and utility lines to prevent transient voltages from entering the facility. Lightning arrestors, surge arrestors, surge protectors, surge suppressors, transient power suppressors, or isolation transformers can be used to help mitigate the flow of transient voltage into a facility. For more information on surge protection, refer to Institute of Electrical and Electronic Engineers (IEEE) Emerald Book, [ANSI/IEEE STD 1100](#), *IEEE Recommended Practice for Powering and Grounding Sensitive Electronic Equipment* and [NFPA 780](#).

3.5.3 Plumbing

Plumbing may be required to provide domestic hot and cold water, sanitary sewer and storm drainage, propane or natural gas piping, steam or hot water piping, floor drains, miscellaneous plumbing fixtures, and chilled water to support the facility's mission requirements. For further plumbing information, visit [AFCESA's Plumbing and Natural Gas Distribution Systems Program](#) web page. The design criteria must comply with [AFJMAN 32-1070](#), *Plumbing*, and the [International Association of Plumbing and Mechanical Officials \(IAPMO\)](#) guidelines.



3.5.4 Fire Protection and Life Safety

This section provides key fire and life safety information that applies to CONUS and overseas locations. For overseas locations, review host nation laws and the Status of Forces Agreements to ensure the most stringent fire and life safety protection requirements are met.

The facility fire and life safety protection design must conform to [UFC 3-600-01](#), [International Building Code \(IBC\)](#), and [NFPA 101](#) standards. [AFCESA's Fire and Life Safety Engineering Program](#) web page provides additional information to integrate cost effective fire protection and life safety design features into the munitions facility design. Additional fire protection and life safety requirements can be found in [DoD 6055.9-STD](#), [AFMAN 91-201](#), [Air Force Occupational Safety and Health \(AFOSH\)](#), [American Water Works Association \(AWWA\) Standard C502](#), *Dry-Barrel Fire Hydrants*, [NFPA 14](#), *Installation of Standpipes, Private Hydrants, and Hose Systems*, and [Occupational Safety and Health Administration \(OSHA\)](#) standards.

A comprehensive facility design plan must be prepared and approved by the base Fire Department to show all fire protection and life safety features and systems. The design plan should include the following information (as a minimum).

1. Planned occupancy of the facility.
2. Occupant load (covering full authorization).
3. Type of construction.
4. Facility mission requirements (e.g., what type of munitions are planned for the facility, how many aircraft in the hangar, etc.).
5. Location of fire-rated walls, doors, and dampers including enclosures for hazardous munitions operating locations. Travel distances for employees working in munitions facilities should be a maximum of 25 ft (7.6 m) from the exit point, but never more than 75 ft (22.8 m). Review criteria in [AFMAN 91-201](#), local building codes, and [NFPA 101](#).
6. Layout for automatic extinguisher systems (per [NFPA 13](#), *Installation of Sprinkler Systems*) and locations of portable fire extinguishers (per [NFPA 10](#), *Standard for Portable Fire Extinguishers*).
7. Specifications for the fire detection/internal alarm systems. Information for fire detection/internal alarm systems can be found at [AFCESA's Fire Detection and Alarm Systems](#) web page.
 - a. The alarm and reporting system that conforms to the latest edition of [NFPA 72](#), *National Fire Alarm Code*.
 - b. A smoke/heat detection system, if appropriate.



- c. Visible (e.g., strobes) and audible notification devices that may be easily detected throughout office and operating areas.
 - d. Carbon monoxide detection, as required.
8. Facility safety markings/signage plan that identifies exits, fire extinguisher locations, and other safety features as outlined in [AFOSH](#) and [OSHA](#) standards, [AFMAN 91-201](#), and [UFC 3-120-01](#).

3.5.5 Energy Conservation Measures

Energy conservation should be a consideration in designing a munitions facility project. Comply with [ETL 94-4](#), *Energy Usage Criteria for Facilities in the Military Construction Program*, when applicable. To make the facility design functional from an energy conservation standpoint, the designer must consider and include, as required, the following energy conservation measures listed below.

1. Heating and cooling equipment should meet efficiencies defined in [Title 10 CFR 435](#), *Energy*, Chapter II and [Energy Star](#) standards.
2. Limited-range thermostats should be used whenever possible. [Title 41 CFR](#), *Federal Property Management Regulation*, and [DoD Energy Managers Handbook](#), provide guidance and thermostat information.
3. Renewable energy technologies, such as ground source heat pumps, high temperature solar, and wind, should be used whenever feasible and cost effective.
4. Solar hot water systems should be considered. Water conservation fixtures, equipment and systems should be used whenever possible. Refer to [MIL HDBK 1165](#), *Water Conservation*, for guidance.

The following additional factors are important when planning energy conservation measures for a munitions facility.

1. Orient the facility to take advantage of winter sun, prevailing winds, and natural landforms (e.g., protection from high winds). Minimize exposure in areas with hot summers.
2. Protect windows from direct summer sun by using overhangs, shades, blinds, solar film, tinted glass, solar screens, and shade from trees. Use weather stripping and caulking to reduce air infiltration.
3. Reduce temperature variation by utilizing energy efficient windows. This may include reduced glass area, window tinting, type of window construction, window placement (i.e., minimize



windows on southern exposures), and the use of dual-panel windows.

4. Consider the type and application of thermal insulation to provide the most long-term economical insulating value for the facility.

3.6 Telecommunications

Telecommunications distribution and cabling systems should be designed and installed in accordance with the latest Engineering Technical Letter (ETL) on pre-wiring, and should adhere to the requirements in [AFI 33-133](#), *Joint Technical Architecture: Air Force (JTA-AF)* and recommendations in the *JTA-AF Fixed Based Technical Architecture, Vol. 6, Building 1040 Wiring Architecture Guide*. The design should be coordinated with the communications squadron.

3.7 Security Criteria

Security and force protection is an essential element of planning and designing Air Force facilities. This section describes munitions facility design measures that minimize the vulnerability of the facilities from terrorist attacks. This section includes information on antiterrorism/force protection (AT/FP) and physical security as well as communications and electronics security for munitions facility design.



Figure 3.17
Security Barriers Protecting
Entrance to Munitions Storage
Area - Cannon AFB, NM

3.7.1 Antiterrorism/Force Protection Criteria

AT/FP considerations must be integrated in the initial stages of the overall design for munitions facilities. Information regarding AT/FP design procedures can be found in [UFC 4-010-01](#), *DoD Minimum Antiterrorism Standards for Buildings*, AFJMAN 32-1071 Volumes 1, 2, and 3, *Security Engineering Manuals* (FOUO), [UFC 4-021-01](#), *Design and O&M: Mass Notification Systems* and [AFI 10-245](#), *Air Force Antiterrorism (AT) Standards*. Units in operational theater commands (e.g., European Command (EUCOM), Pacific Command (PACOM), etc.), must comply with their respective command's and host nation AT/FP guidelines.



Figure 3.18
Security Lighting on
Segregated Magazine -
Langley AFB, VA

3.7.2 Physical Security

Physical security issues should be addressed during the planning and design of the site layout and building systems to enhance the physical security of the occupants, infrastructure, and munitions assets. The basic design criteria can be found in the [Installation Force Protection Guide](#) and [AFI 31-101](#), *The Air Force Installation Security Program*. Specific design features for protecting munitions determined as sensitive arms, ammunition, and explosives (AA&E) (as defined by [DoD 5100.76-M](#), *Physical Security of Sensitive Conventional Arms, Ammunition, and Explosives*) are identified in [AFH 32-1084](#). Where applicable, provide



necessary infrastructure to support high-tech security devices such as remotely operated weapons systems.

3.7.2.1 Facility Site Design

Guidelines for site location planning address force protection issues such as orientation of buildings, integration of vehicle access, control points, physical barriers, placement of windows, landscaping, parking, and protection of utilities. Exterior utility systems and functional design concepts are also key design components for force protection.

3.7.2.2 Building Design

Facility design standards, such as architectural, structural, mechanical, interior design, and electrical systems are also important design elements for force protection. Building design can minimize the vulnerability to attack and loss of life through deterrence and detection, and strengthen the structure against a variety of terrorist tactics per [DoD 5100.76-M](#), [Military Handbook 1013/1A](#), *Military Handbook Design Guidelines for Physical Security of Fixed Land-Based Facilities*, and [AFI 31-101](#).

3.7.3 Communications and Electronic Security

Communications and electronic security planning is a key element for the overall facility and site layout. Incorporate telecommunications and surveillance systems into the design that contribute significantly to security protection for munitions facilities. Key facilities such as Munitions Control and the entry control point to the munitions storage area can greatly benefit from use of intrinsically installed surveillance equipment. The advent of additional accountability, internal management, and munitions-specific research engines may place great demands on the telecommunications infrastructure. It is paramount that all aspects of electronic security and telecommunications systems infrastructure be designed to allow for future expansion.

3.7.3.1 Telecommunications Systems Design

Telecommunications planning is critical to system information assurance (security) issues such as operations, communications, computer, physical, and emission security. Guidelines for incorporating telecommunications systems into munitions facility design to optimize telecommunications security protection can be found in [AFI 33-104](#), *Base-Level Planning and Implementation*, [ETL 02-12](#), *Communication and Information Systems Criteria for Air Force Facilities*, and [AFMAN 33-105](#), *Engineering and Installation Services*.

3.7.3.2 Electronic Intrusion Detection Equipment (IDE) and Systems (IDS) Design

IDE helps ensure minimum protection requirements by promptly detecting an attack on the area it is protecting. The IDE is part of an overarching IDS comprised of equipment and components used to detect and track intrusions, report and display alarms, remotely assess alarms,

Additional Security References

[AFPAM 32-1010](#), *Land Use Planning*

[U.S. Air Force Installation Force Protection Guide](#)

[DODI 2000.16](#), *DoD Antiterrorism Standards*

[UFC 4-010-01](#), *DoD Minimum Antiterrorism Standards for Buildings*

[AFJMAN 32-1071 Volumes 1, 2, and 3](#), *Security Engineering Manuals (FOUO)*

[UFC 4-021-01](#), *Design and O&M: Mass Notification Systems*

[DoD 5100.76-M](#), *Physical Security of Sensitive Conventional Arms, Ammunition, and Explosives*



Figure 3.19
High Security Hasp on Storage Igloo - Luke AFB, AZ



and alert security forces to enhance the protection of resources and facilities. The guidelines for incorporating IDE and IDS into munitions facility designs can be found in **AFI 31-101**.

ARCHIVED





TABLE OF CONTENTS

CHAPTER 4: DESIGN STANDARDS

4.1	PURPOSE AND SCOPE	4-1
4.1.1	Maintenance Facilities	4-2
4.1.2	Storage Facilities.....	4-2
4.1.3	Transportation Facilities	4-2
4.1.4	Administration Facilities.....	4-3
4.2	MAINTENANCE FACILITIES	4-3
4.2.1	Category Code 171-875, Munitions Loading Crew Training Facility.....	4-5
4.2.1.1	Facility-Specific Construction Requirements	4-5
4.2.1.2	Facility-Specific Spatial Requirements.....	4-5
4.2.1.3	Facility-Specific Mechanical Requirements	4-5
4.2.1.4	Facility-Specific Electrical Requirements	4-6
4.2.1.5	Other Specific Requirements	4-6
4.2.2	Category Code 212-212, Missile Assembly Shop/Integrated Maintenance Facility (IMF).....	4-13
4.2.2.1	Facility-Specific Construction Requirements	4-13
4.2.2.2	Facility-Specific Spatial Requirements.....	4-13
4.2.2.3	Facility-Specific Mechanical Requirements	4-13
4.2.2.4	Facility-Specific Electrical Requirements	4-14
4.2.2.5	Other Specific Requirements	4-14
4.2.3	Category Code 212-213, Tactical Missile/Glide Weapon Maintenance Shop	4-17
4.2.3.1	Facility-Specific Construction Requirements	4-17
4.2.3.2	Facility-Specific Spatial Requirements.....	4-17
4.2.3.3	Facility-Specific Mechanical Requirements	4-17
4.2.3.4	Facility-Specific Electrical Requirements	4-18
4.2.3.5	Other Specific Requirements	4-18
4.2.4	Category Code 215-552, Weapons and Release Systems Shop	4-25
4.2.4.1	Facility-Specific Construction Requirements	4-25
4.2.4.2	Facility-Specific Spatial Requirements.....	4-25
4.2.4.3	Facility-Specific Mechanical Requirements	4-25
4.2.4.4	Facility-Specific Electrical Requirements	4-26
4.2.4.5	Other Specific Requirements	4-26
4.2.5	Category Code 215-582, Surveillance and Inspection Shop	4-33
4.2.5.1	Facility-Specific Construction Requirements	4-33
4.2.5.2	Facility-Specific Spatial Requirements.....	4-33
4.2.5.3	Facility-Specific Mechanical Requirements	4-33
4.2.5.4	Facility-Specific Electrical Requirements	4-33
4.2.5.5	Other Specific Requirements	4-34
4.2.6	Category Code 216-642, Conventional Munitions Maintenance Shop	4-39
4.2.6.1	Facility-Specific Construction Requirements	4-39
4.2.6.2	Facility-Specific Spatial Requirements.....	4-39
4.2.6.3	Facility-Specific Mechanical Requirements	4-39



4.2.6.4	Facility-Specific Electrical Requirements	4-39
4.2.6.5	Other Specific Requirements	4-39
4.2.7	Category Code 218-712, Aircraft Support Equipment Shop/Storage Facility (Aerospace Ground Equipment (AGE) Facility) - Used for Munitions Support Equipment Maintenance	4-49
4.2.7.1	Facility-Specific Construction Requirements	4-49
4.2.7.2	Facility-Specific Spatial Requirements.....	4-49
4.2.7.3	Facility-Specific Mechanical Requirements	4-49
4.2.7.4	Facility-Specific Electrical Requirements	4-50
4.2.7.5	Other Specific Requirements	4-50
4.3	MUNITIONS STORAGE FACILITIES.....	4-53
4.3.1	Category Code 422-253, Multi-cubicle Magazine Storage	4-55
4.3.1.1	Facility-Specific Construction Requirements	4-55
4.3.1.2	Facility-Specific Spatial Requirements.....	4-55
4.3.1.3	Facility-Specific Mechanical Requirements	4-55
4.3.1.4	Facility-Specific Electrical Requirements	4-55
4.3.1.5	Other Specific Requirements	4-55
4.3.2	Category Code 422-256, Rocket Check Out and Assembly Storage.....	4-63
4.3.2.1	Facility-Specific Construction Requirements	4-63
4.3.2.2	Facility-Specific Spatial Requirements.....	4-63
4.3.2.3	Facility-Specific Mechanical Requirements	4-63
4.3.2.4	Facility-Specific Electrical Requirements	4-63
4.3.2.5	Other Specific Requirements	4-64
4.3.3	Category Code 422-257, Segregated Magazine Storage	4-67
4.3.3.1	Facility-Specific Construction Requirements	4-67
4.3.3.2	Facility-Specific Spatial Requirements.....	4-67
4.3.3.3	Facility-Specific Mechanical Requirements	4-67
4.3.3.4	Facility-Specific Electrical Requirements	4-67
4.3.3.5	Other Specific Requirements	4-67
4.3.4	Category Code 422-258, Above Ground Magazine Storage	4-73
4.3.4.1	Facility-Specific Construction Requirements	4-73
4.3.4.2	Facility-Specific Spatial Requirements.....	4-73
4.3.4.3	Facility-Specific Mechanical Requirements	4-73
4.3.4.4	Facility-Specific Electrical Requirements	4-73
4.3.4.5	Other Specific Requirements	4-73
4.3.5	Category Code 422-264, Storage Igloo	4-83
4.3.5.1	Facility-Specific Construction Requirements	4-83
4.3.5.2	Facility-Specific Spatial Requirements.....	4-83
4.3.5.3	Facility-Specific Mechanical Requirements	4-83
4.3.5.4	Facility-Specific Electrical Requirements	4-83
4.3.5.5	Other Specific Requirements	4-83
4.3.6	Category Code 422-265, Inert Spares Storage.....	4-91
4.3.6.1	Facility-Specific Construction Requirements	4-91
4.3.6.2	Facility-Specific Spatial Requirements.....	4-91
4.3.6.3	Facility-Specific Mechanical Requirements	4-91
4.3.6.4	Facility-Specific Electrical Requirements	4-91



4.3.6.5	Other Specific Requirements	4-91
4.3.7	Category Code 422-271, Module Barricaded Storage	4-95
4.3.7.1	Facility-Specific Construction Requirements	4-95
4.3.7.2	Facility-Specific Spatial Requirements	4-95
4.3.7.3	Facility-Specific Mechanical Requirements	4-95
4.3.7.4	Facility-Specific Electrical Requirements	4-95
4.3.7.5	Other Specific Requirements	4-95
4.3.8	Category Code 422-275, Ancillary Explosives Facility	4-99
4.3.8.1	Facility-Specific Construction Requirements	4-99
4.3.8.2	Facility-Specific Spatial Requirements	4-99
4.3.8.3	Facility-Specific Mechanical Requirements	4-100
4.3.8.4	Facility-Specific Electrical Requirements	4-100
4.3.8.5	Other Specific Requirements	4-100
4.4	TRANSPORTATION FACILITIES	4-109
4.4.1	Category Code 116-662, Pad, Dangerous Cargo	4-111
4.4.1.1	Facility-Specific Construction Requirements	4-111
4.4.1.2	Facility-Specific Spatial Requirements	4-111
4.4.1.3	Facility-Specific Mechanical Requirements	4-112
4.4.1.4	Facility-Specific Electrical Requirements	4-112
4.4.1.5	Other Special Requirements	4-112
4.4.2	Category Code 422-277 Munitions Holding Point	4-115
4.4.2.1	Facility-Specific, Construction Requirements	4-115
4.4.2.2	Facility-Specific Spatial Requirements	4-115
4.4.2.3	Facility-Specific Mechanical Requirements	4-116
4.4.2.4	Facility-Specific Electrical Requirements	4-116
4.4.2.5	Other Specific Requirements	4-116
4.4.3	Category Code 851-147, Explosives Movement Routes	4-119
4.4.4	Category Code 852-261, Vehicle Parking	4-121
4.4.4.1	Facility-Specific Construction Requirements	4-121
4.4.4.2	Facility-Specific Spatial Requirements	4-121
4.4.4.3	Facility-Specific Electrical Requirements	4-122
4.4.4.4	Other Specific Requirements	4-122
4.4.5	Category Code 890-158, Load and Unload Platform (Railhead)	4-123
4.4.5.1	Facility-Specific Construction Requirements	4-123
4.4.5.2	Facility-Specific Spatial Requirements	4-123
4.4.5.3	Facility-Specific Mechanical Requirements	4-123
4.4.5.4	Facility-Specific Electrical Requirements	4-123
4.4.5.5	Other Specific Requirements	4-124
4.5	MUNITIONS ADMINISTRATION FACILITIES	4-125
4.5.1	Category Code 610-144, Munitions Administration Facility	4-127
4.5.1.1	Facility-Specific Construction Requirements	4-127
4.5.1.2	Facility-Specific Spatial Requirements	4-127
4.5.1.3	Facility-Specific Mechanical Requirements	4-127
4.5.1.4	Facility-Specific Electrical Requirements	4-128
4.5.1.5	Other Specific Requirements	4-128





LIST OF FIGURES

CHAPTER 4: DESIGN STANDARDS

FIGURE 4.1	Munitions Loading Crew Training Facility - Luke AFB, AZ	4-5
FIGURE 4.2	Munitions Loading Crew Training Facility - Cannon AFB, NM	4-6
FIGURE 4.3	IMF - Barksdale AFB, LA	4-13
FIGURE 4.4	IMF Work Bay - Barksdale AFB, LA	4-13
FIGURE 4.5	Tactical Missile/Glide Weapon Maintenance Shop - Barksdale AFB, LA	4-17
FIGURE 4.6	Tactical Missile/Glide Weapon Maintenance Shop - Luke AFB, AZ	4-17
FIGURE 4.7	Tactical Missile/Glide Weapon Maintenance Shop - Langley AFB, VA	4-18
FIGURE 4.8	Weapons and Release System Shop - Cannon AFB, NM	4-25
FIGURE 4.9	Weapons and Release System Shop - Luke AFB, AZ	4-25
FIGURE 4.10	Surveillance and Inspection Shop - Langley AFB, VA	4-33
FIGURE 4.11	Surveillance and Inspection Shop - McChord AFB, WA	4-33
FIGURE 4.12	Conventional Munitions Maintenance Shop - Cannon AFB, NM	4-39
FIGURE 4.13	Conventional Munitions Maintenance Shop - Luke AFB, AZ	4-39
FIGURE 4.14	Powered Trailer Facility - Barksdale AFB, LA	4-49
FIGURE 4.15	Multi-cubicle Magazine Storage - McChord AFB, WA	4-55
FIGURE 4.16	Multi-cubicle Magazine Storage - Langley AFB, VA	4-55
FIGURE 4.17	Segregated Magazine Storage - Langley AFB, VA	4-67
FIGURE 4.18	Segregated Magazine Storage - Luke AFB, AZ	4-67
FIGURE 4.19	Segregated Magazine Storage - McChord AFB, WA	4-67
FIGURE 4.20	Above Ground Magazine Storage - Cannon AFB, NM	4-73
FIGURE 4.21	Above Ground Magazine Storage - Luke AFB, AZ	4-73
FIGURE 4.22	Storage Igloo - Luke AFB, AZ	4-83
FIGURE 4.23	Inert Spares Storage - Luke AFB, AZ	4-91
FIGURE 4.24	Inert Spares Storage - Langley AFB, VA	4-91
FIGURE 4.25	Ancillary Explosives Facility - Munitions Loading/Unloading Dock - Luke AFB, AZ	4-99
FIGURE 4.26	Ancillary Explosives Facility - MAC Pad - Cannon AFB, NM	4-99
FIGURE 4.27	Ancillary Explosives Facility - Barksdale AFB, LA	4-100
FIGURE 4.28	Dangerous Cargo Pad - McChord AFB, WA	4-111
FIGURE 4.29	Dangerous Cargo Pad - Langley AFB, VA	4-111
FIGURE 4.30	Munitions Holding Point - Luke AFB, AZ	4-115
FIGURE 4.31	Munitions Holding Point - McChord AFB, WA	4-115
FIGURE 4.32	Explosives Movement Route - Langley AFB, VA	4-119
FIGURE 4.33	Explosives Movement Route - Barksdale AFB, LA	4-119
FIGURE 4.34	Government Vehicle and Equipment Parking - Langley AFB, VA	4-121
FIGURE 4.35	Vehicle Parking - Barksdale AFB, LA	4-121
FIGURE 4.36	Government Vehicle and Equipment Parking - Luke AFB, AZ	4-122
FIGURE 4.37	Munitions Administration Facility - Luke AFB, AZ	4-127
FIGURE 4.38	Munitions Administration Facility - Cannon AFB, NM	4-127
FIGURE 4.39	Munitions Administration Facility - McChord AFB, WA	4-128





LIST OF ILLUSTRATED CATEGORY CODES

171-875	Munitions Loading Crew Training Facility	4-7
212-212	Missile Assembly Shop/Integrated Maintenance Facility (IMF).....	4-15
212-213	Tactical Missile/Glide Weapon Maintenance Shop.....	4-19
215-552	Weapons and Release Systems Shop.....	4-27
215-582	Surveillance and Inspection Shop.....	4-35
216-642	Conventional Munitions Maintenance Shop.....	4-41
218-712	Aircraft Support Equipment Shop/Storage Facility – Used for Munitions Support Equipment.....	4-51
422-253	Multi-cubicle Magazine Storage.....	4-57
422-256	Rocket Check Out and Assembly Storage.....	4-65
422-257	Segregated Magazine Storage.....	4-69
422-258	Above Ground Magazine Storage.....	4-75
422-264	Storage Igloo.....	4-85
422-265	Inert Spares Storage	4-93
422-271	Module Barricaded Storage	4-97
422-275	Ancillary Explosives Facility.....	4-103
116-662	Pad, Dangerous Cargo	4-113
422-277	Munitions Holding Point.....	4-117
610-144	Munitions Administration Facility.....	4-131

ARCHIVED



ARCHIVED



4.1 Purpose and Scope

This chapter provides detailed information on munitions facilities design standards for 21 munitions-related civil engineering (CE) real property category codes (Cat Codes). It is broken down into four sections corresponding to the major facility classes: Maintenance, Storage, Transportation, and Administration.

For most of the Cat Codes in this document, a description of the facility is provided along with overall design requirements. This is followed by facility-specific requirements under the following five categories:

1. Construction
2. Spatial Requirements
3. Mechanical Requirements
4. Electrical Requirements
5. Other Specific Requirements

To aid designers when preparing designs for munitions facilities projects, this chapter contains “best in class” design examples from selected Air Force installations for each Cat Code (where available). Department of Defense Explosives Safety Board (DDESB)-approved facility designs are noted on the design examples. For requirements common to munitions facilities, such as security and communications requirements, please refer to Chapter 3, “General Design Guidance”.

[AFH 32-1084](#), *Facility Requirements*, is the Air Force’s handbook for determining spatial and other physical requirements for common Air Force facilities. [AFH 32-1084](#) provides guidance on 17 of the 21 munitions facilities addressed in this munitions design standard. The four facilities not included in AFH 32-1084 are:

- Category Code 422-253 – Multi-cubicle Magazine Storage
- Category Code 422-257 – Segregated Magazine Storage
- Category Code 610-144 – Munitions Administration Facility
- Category Code 890-158 – Load and Unload Platform (Railhead) – Used for Munitions Operations

[AFMAN 91-201](#), *Explosives Safety Standards*, is the Air Force’s primary source document for explosives safety criteria. Other Air Force requirements and guidance documents that provide munitions facilities criteria are listed in Chapter 5, “References, Forms, Abbreviations and Acronyms, and Terms”, of this document and are identified in the discussion of each facility type in this chapter.



4.1.1 Maintenance Facilities

- 171-875 Munitions Loading Crew Training Facility
- 212-212 Missile Assembly Shop/Integrated Maintenance Facility (IMF)
- 212-213 Tactical Missile/Glide Weapons Maintenance Shop
- 215-552 Weapons and Release Systems Shop
- 215-582 Surveillance and Inspection Shop
- 216-642 Conventional Munitions Shop
- 218-712 Aircraft Support Equipment Shop/Storage Facility (Aerospace Ground Equipment (AGE) Facility) – Used for Munitions Support Equipment Maintenance

4.1.2 Storage Facilities

- 422-253 Multi-cubicle Magazine Storage
- 422-256 Rocket Check Out and Assembly Storage
- 422-257 Segregated Magazine Storage
- 422-258 Above Ground Magazine Storage
- 422-264 Storage Igloo (Earth-covered Magazine)
- 422-265 Inert Spares Storage
- 422-271 Module Barricaded Storage
- 422-275 Ancillary Explosives Facility (Classification Yard, Holding Yard, Inspection Station, Interchange Yard, Loading Dock, Ready Explosive Facility, and Bomb Preload Station/Munitions Assembly Conveyor (MAC) pad)

4.1.3 Transportation Facilities

- 116-662 Pad, Dangerous Cargo
- 422-277 Flight Line Munitions Holding Point
- 851-147 Roads (Streets) – Primary and Alternate Explosives Movement Routes



Basic Design Standards for Munitions Maintenance Facilities

- * [AFH 32-1084](#), *Facility Requirements*
- * [AFI 32-1021](#), *Planning and Programming Military Construction (MILCON) Projects*
- * [AFMAN 91-201](#), *Explosives Safety Standards*
- * [TM 5-1300/AFM 88-22](#), *Structures to Resist the Effects of Accidental Explosives*
- * [DoD 5100.76-M](#), *Physical Security of Sensitive Conventional Arms, Ammunition and Explosives*
- * [DoD 6055.9-STD](#), *Ammunition and Explosives Safety Standard*
- * [AFJMAN 32-8008, Vol 1](#), *General Provisions for Airfield/Heliport Pavement Design*
- * [DoD 4500.9-R Regulation](#), *Defense Transportation Regulation (DTR) Part II*
- * [UFC-3-260-01](#), *Airfield and Heliport Planning and Design.*
- * [Mil HDBK 1013/1A](#), *Design Guidelines for Physical Security of Facilities*
- * [Technical Order](#) (T.O.) 11A-1-61-4, and pertinent technical orders of the 11A, 11C, 11G, 11K, 11N, and 11P series.

852-261 Vehicle Parking Operations – Used for Munitions Sub Pool Parking

890-158 Load and Unload Platform (Railhead) – Used for Munitions Operations

4.1.4 Administration Facilities

610-144 Munitions Administration Facility

4.2 Maintenance Facilities

Munitions maintenance facilities provide for the assembly, repair, configuration changes, inspection, corrosion control, and other tasks involving conventional munitions. They are not authorized for storage of munitions assets except for temporary storage of operational quantities to meet mission requirements.

When designing munitions maintenance facilities, concurrent explosives operations or dissimilar activities (which may require stand-off distances or substantial dividing walls) need to be evaluated. These activities may occur within the same building at the discretion of the Major Command (MAJCOM)/SEW. The criteria for these activities may vary by MAJCOM. Check with the base Weapons Safety Manager (WSM) in the early phase of facility planning for this determination.



Please see the next page.

ARCHIVED



4.2.1 Category Code 171-875 Munitions Loading Crew Training Facility

This facility is used for munitions loading crew training. Munitions loading crews use this facility to acquire and maintain proficiency on assigned weapon system(s). Classroom space is required to teach the academic portion of activities related to equipment operation, munitions safety attributes, and aircraft loading. Restrooms and a break area are authorized for this facility.

The loading crew training facility is usually located adjacent to the flight line. It may require explosives siting if the facility falls within the arc of the combat aircraft parking area. If outside the explosives clear zone, the facility may require an explosives license if aircraft explosives components are stored within the facility. Where space is limited, the classroom training may be separated from the aircraft-related training area. Similar types of aircraft training functions should be located in a consolidated facility whenever possible.

4.2.1.1 Facility-Specific Construction Requirements

Not applicable.

4.2.1.2 Facility-Specific Spatial Requirements

The training facility is a combination of classroom and open/covered/hangar space for training on static aircraft.



Figure 4.1
Munitions Loading Crew
Training Facility -
Luke AFB, AZ

1. Classroom space requirements are based on projected student loads and are determined using [AFH 32-1084](#). Additional classroom space may be allocated for training aids, mockups, and static display munitions.
2. Aircraft-related training should be conducted outdoors, if possible, to duplicate operational conditions to the maximum extent possible. Where environmental factors adversely impact outdoor training, provide a covered area or interior hangar space appropriate for the training operation. Adequate space for aircraft movement, storage and handling of training aids, support equipment, and inert munitions training items must be included in the hands-on training area.

4.2.1.3 Facility-Specific Mechanical Requirements

Heating, ventilation, and air conditioning (HVAC) requirements for office and classroom areas must comply with requirements defined in Chapter 3, “General Design Guidance.”



4.2.1.4 Facility-Specific Electrical Requirements

1. Provide convenience outlets to support computers, audiovisual equipment, break areas, and other usual and customary equipment associated with administrative and classroom training areas as described in [TM 5-811](#), *Electrical Design, Interior Electrical System*,
2. If facility is explosives sited or licensed, provide grounding, and surge protection as per [AFMAN 91-201](#).
3. Provide a lightning protection system (LPS) as required in [NFPA 780](#), Chapter 3.



Figure 4.2
Munitions Loading Crew
Training Facility -
Cannon AFB, NM

4.2.1.5 Other Specific Requirements

If located within the explosives clear zone, the facility must be included in the explosives site plan (ESP). If located outside the explosives clear zone and explosives items are removed from the system and stored in the facility, an explosives license is required. [DoD 6055.9 STD](#), *DoD Ammunition and Explosives Safety Standards*, and [AFMAN 91-201](#) outline explosives safety and siting/licensing requirements.

ARCHIVED



Location: Cannon AFB, New Mexico
Command: ACC
Facility Number: 133
Date Constructed: 1993

Design

- Three-bay hangar design
- 576 sq ft (53.51 m²) classroom consolidated in hangar

Facility Overview

Facility is used for Munitions Loading Crew Training on F-16 aircraft. The three aircraft bays allow segregation of training, support equipment, and munitions assets for the varying mission profiles. The hangar bays were originally designed for F-111 aircraft and are slightly larger than required for the F-16. The classroom is consolidated in the hangar and services all three hangar bays.

Space Usage
 Size (Total) 35,563 sq ft (3,303.91m²)



Large Unobstructed Training Space



Wide Hangar Doors

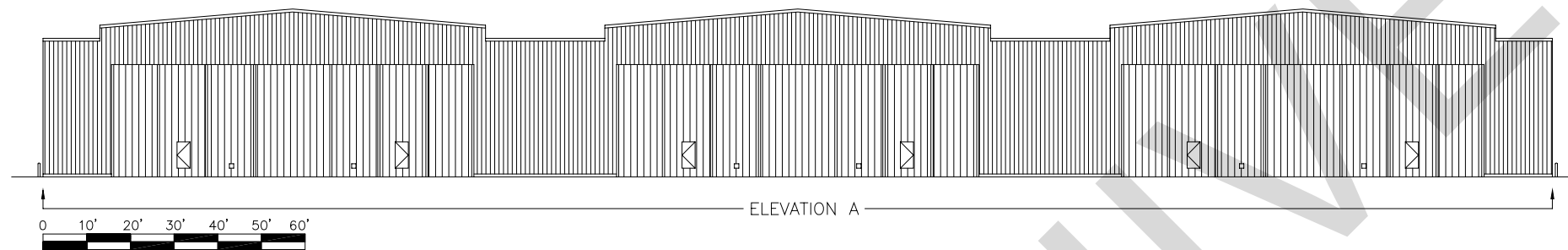

Facility Elevation

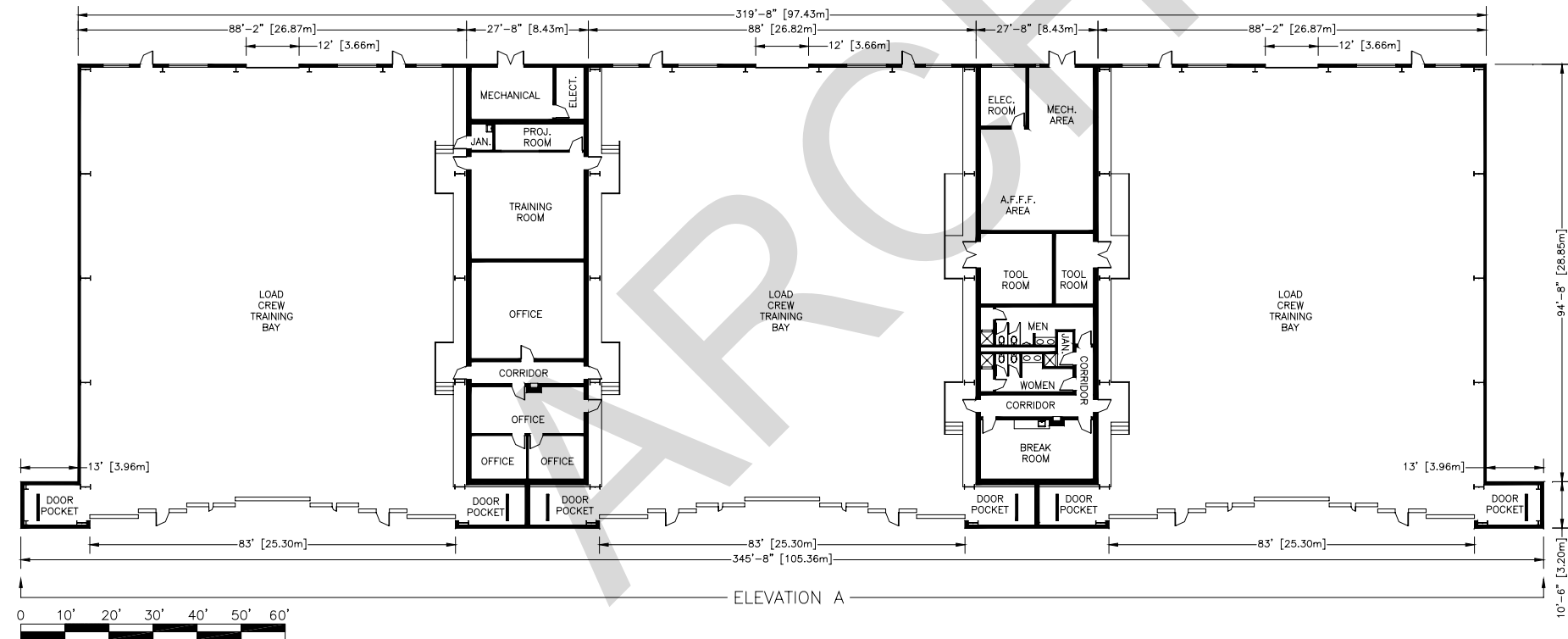

Facility Floor Plan

Category Code 171-875
Munitions Loading Crew Training Facility

- Design Related to Aircraft Type**
 Aircraft Type: Fighter
 Primary Aircraft: F-16 (originally F-111)

- Stand Alone Facility**
- Consolidated Facility**
 Other Uses:

- Single Wing**
- Multiple Wings**

Structural	<ul style="list-style-type: none"> • Dependent on location, provide covered training space (dock or hangar) based on aircraft supported. • Classroom space per AFH 32-1084 plus room for training aids • Storage space (tool, supply, training aids, equipment, etc.) based on mission requirements • Minimum 1,500 sq ft (137 m²) administration area
Electrical	<ul style="list-style-type: none"> • Typical UL-approved lighting for an aircraft hangar • Minimum 5 foot-candles interior lighting
Fire/Safety	<ul style="list-style-type: none"> • Provide lightning protection details per NFPA 780 and MIL HDBK 419 • Provide blast-resistant windows if facility is within the explosives clear zone • Provide ventilation and exhaust systems based on bioenvironmental survey • Provide grounding system per AFI 32-1065
Force Protection	<ul style="list-style-type: none"> • Provide high security hasps and intrusion detection system per AFI 31-101 • Install exterior security lighting based on local threat assessment
Equipment	<ul style="list-style-type: none"> • No specific requirements noted

- Other References:**
- AFH 32-1084 – Facilities Requirements
 - AFMAN 91-201 – Explosives Safety Standards
 - AFI 31-101 – The Physical Security Program
 - DoD 6055.9 STD – DoD Ammunition and Explosives Safety Standards

ARCHIVED

Please see the next page.

Location: Luke AFB, Arizona
Command: AETC
Facility Number: 485
Date Constructed: 1988

Facility Overview

Facility is used for Munitions Loading Crew Training in a consolidated facility that is also utilized for F-16 Crew Chief Training. Each activity is assigned one of the two hangar bays at the facility. The two activities share a 48-seat auditorium/classroom.

Design

- Two-bay hangar design with administrative and academic areas in the center
- Hangar space totals 11,215 sq ft (1,041.90m²)
- Anodized, standing seam metal roof

Space Usage

Size (Total Facility) 35,500 sq ft (3,298.06m²)
 Category Code 171-875 11,215 sq ft (1,041.90m²)
 Category Code 211-177 24,285 sq ft (2,256.16m²)



Large Classroom with Audio Visual Support



Small Classroom



Facility Elevation (NTS)

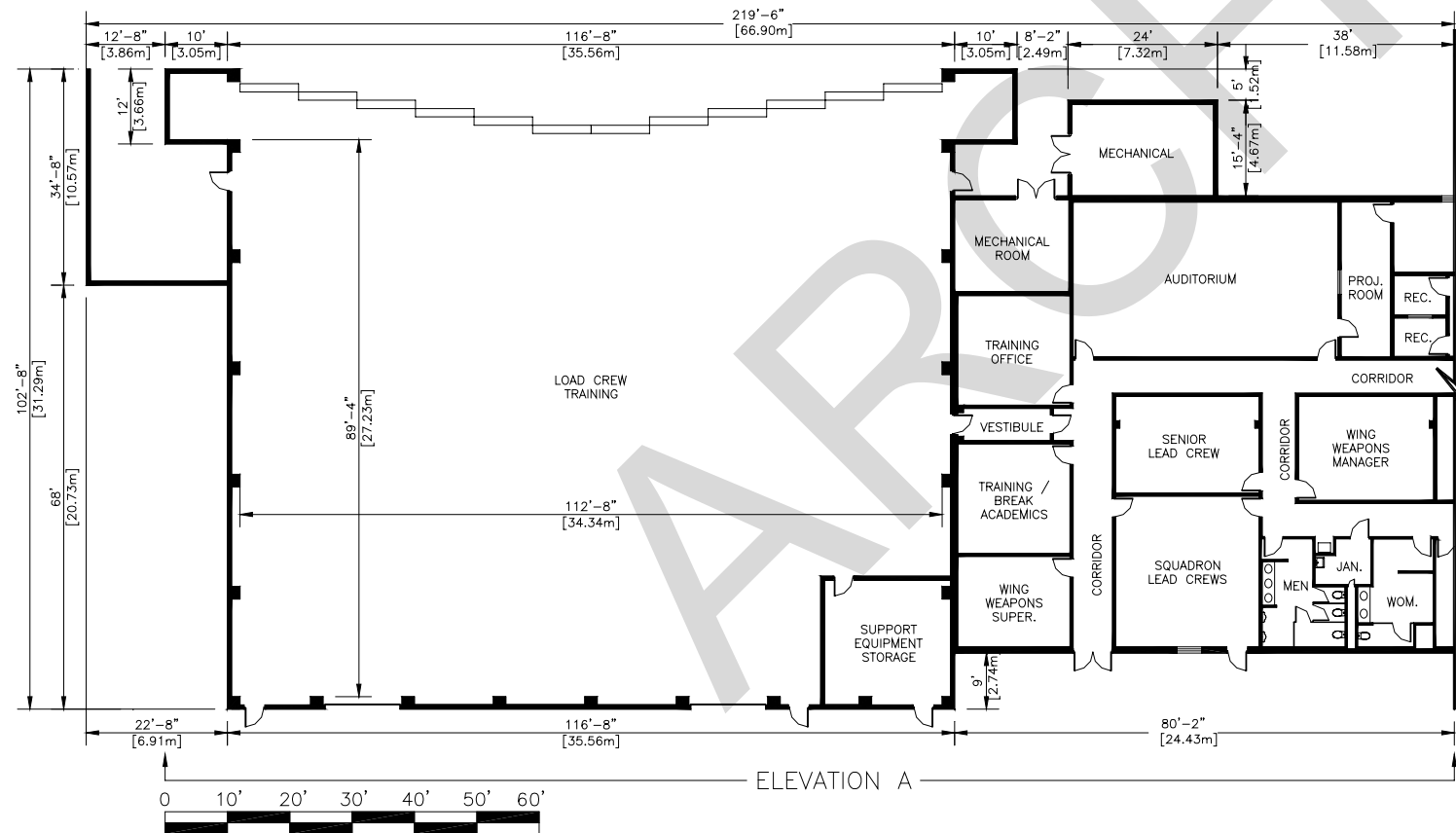

Facility Layout

Category Code 171-875
Munitions Loading Crew Training Facility

<input checked="" type="checkbox"/>	Design Related to Aircraft Type
	Aircraft Type: Fighter Primary Aircraft: F-16
<input type="checkbox"/>	Stand Alone Facility
<input checked="" type="checkbox"/>	Consolidated Facility
	Other Uses: F-16 Crew Chief Training (211-177)
<input checked="" type="checkbox"/>	Single Wing
<input type="checkbox"/>	Multiple Wings

Structural	<ul style="list-style-type: none"> • Dependent on location, provide covered training space (dock or hangar) based on aircraft supported • Classroom space per AFH 32-1084 plus room for training aids • Storage space (tool, supply, training aids, equipment, etc.) based on mission requirements • Minimum 1,500 sq ft (137m²) administration area
Electrical	<ul style="list-style-type: none"> • Typical UL-approved lighting for an aircraft hangar • Minimum 5 foot-candles interior lighting
Fire/Safety	<ul style="list-style-type: none"> • Provide lightning protection details per NFPA 780 and MIL HDBK 419 • Provide blast-resistant windows if facility is within the explosives clear zone • Provide ventilation and exhaust systems based on bioenvironmental survey • Provide grounding system per AFI 32-1065
Force Protection	<ul style="list-style-type: none"> • Provide high security hasps and intrusion detection system per AFI 31-101 • Install exterior security lighting based on local threat assessment
Equipment	<ul style="list-style-type: none"> • No specific requirements noted

- Other References:**
- AFH 32-1084 – Facilities Requirements
 - AFMAN 91-201 – Explosives Safety Standards
 - AFI 31-101 – The Physical Security Program
 - DoD 6055.9 STD – DoD Ammunition and Explosives Safety Standards

ARCHIVED

Please see the next page.

Location: Whiteman AFB, Missouri
Command: ACC
Facility Number: 14
Date Constructed: 1991

Design

- High-bay training space allows for the use of a B-2 bomb bay mock-up
- Classrooms designed to accommodate large groups

Facility Overview

Facility is used for Munitions Loading Crew Training and includes high-bay training space, classroom space, administrative office space, common areas, and equipment storage space. Multiple types of space are combined in this facility to accommodate all training and administrative requirements in support of Munitions Loading Crew Training, the Weapons Manager, and the Loading Standardization Crew.

Space Usage

Size (Total Facility) 31,600 sq ft (2,935.71m²)
 Category Code 171-875 21,296 sq ft (1978.46m²)
 Category Code 215-552 10,304 sq ft (957.27m²)



Exterior View



Interior View of Bay

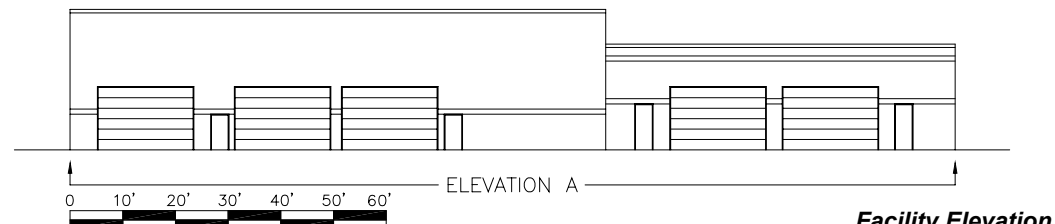

Facility Elevation

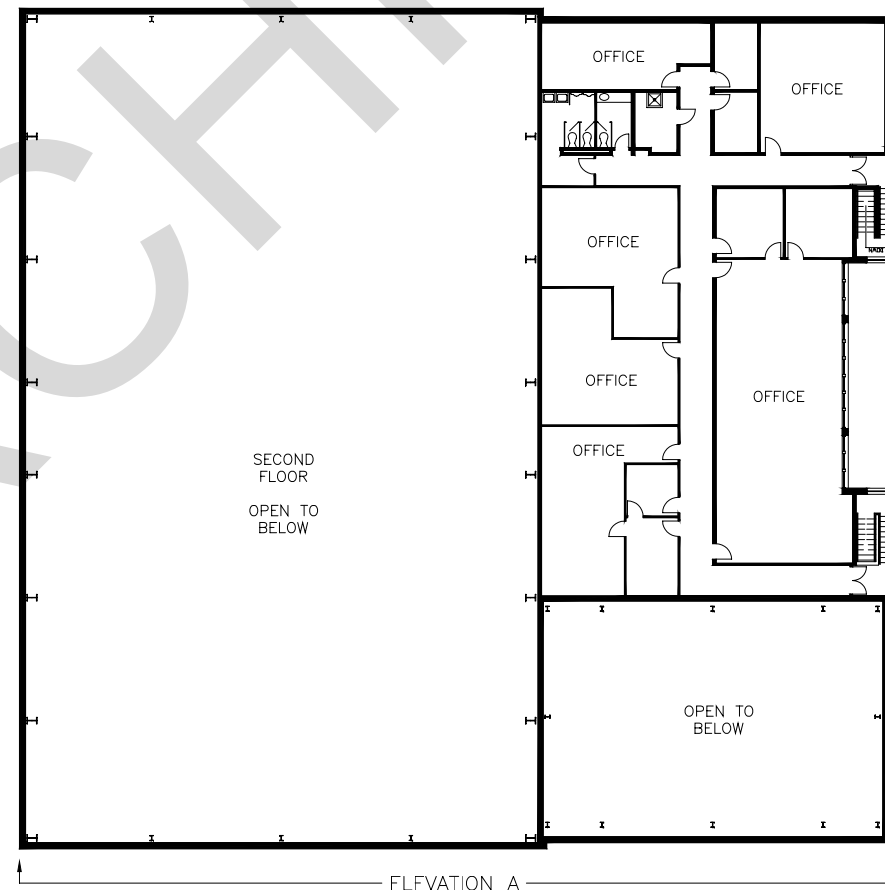
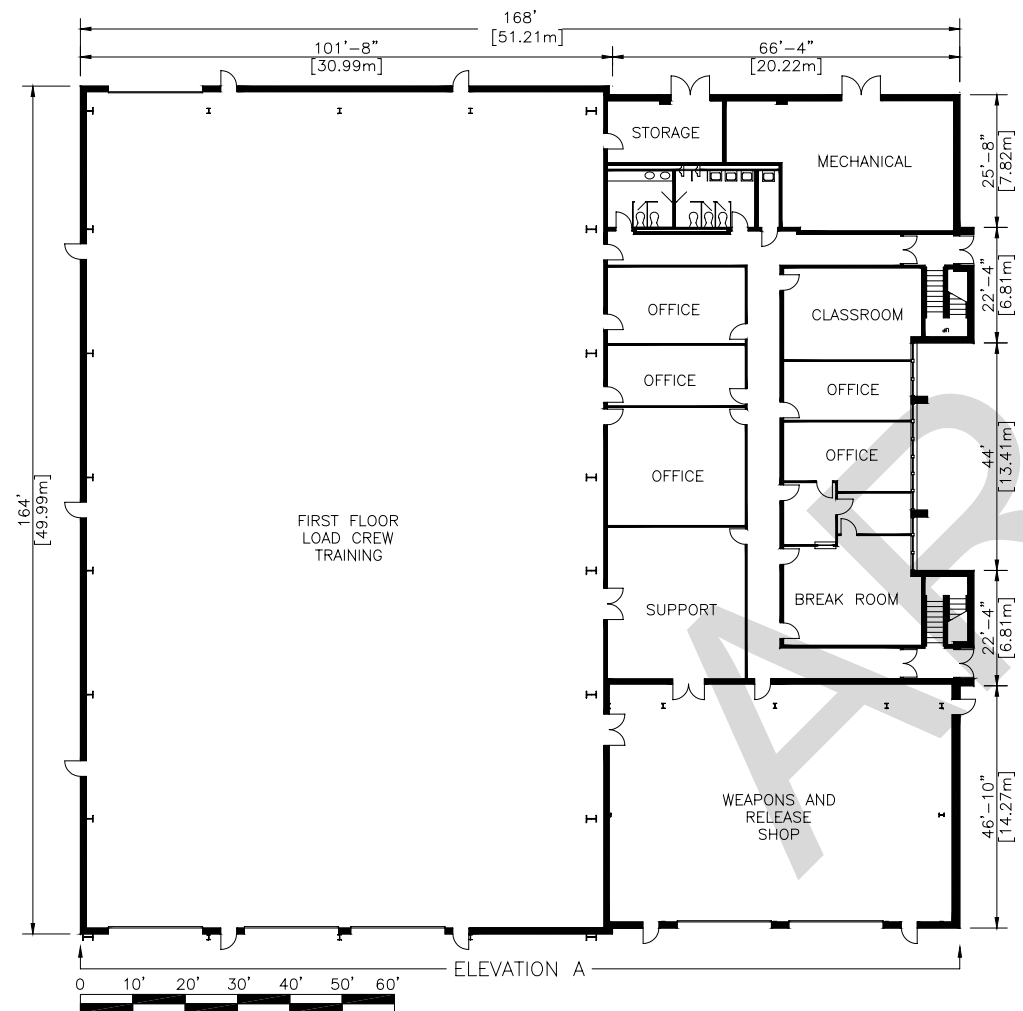

Facility Floor Plan

Category Code 171-875
Munitions Loading Crew Training Facility

- Design Related to Aircraft Type**
 Aircraft Type: Bomber
 Primary Aircraft: B-2

- Stand Alone Facility**
- Consolidated Facility**
 Other Uses: Weapons and Release Shop (215-552)

- Single Wing**
- Multiple Wings**

Structural	<ul style="list-style-type: none"> • Dependent on location, provide covered training space (dock or hangar) based on aircraft supported • Classroom space per AFH 32-1084 plus room for training aids • Storage space (tool, supply, training aids, equipment, etc.) based on mission requirements • Minimum 1,500 sq ft (137 m²) administration area
Electrical	<ul style="list-style-type: none"> • Typical UL-approved lighting for an aircraft hangar • Minimum 5 foot-candles interior lighting
Fire/Safety	<ul style="list-style-type: none"> • Provide lightning protection details per NFPA 780 and MIL HDBK 419 • Provide blast-resistant windows if facility is within the explosives clear zone • Provide ventilation and exhaust systems based on bioenvironmental survey • Provide grounding system per AFI 32-1065
Force Protection	<ul style="list-style-type: none"> • Provide high security hasps and intrusion detection system per AFI 31-101 • Install exterior security lighting based on local threat assessment
Equipment	<ul style="list-style-type: none"> • No specific requirements noted

- Other References:**
- AFH 32-1084 – Facilities Requirements
 - AFMAN 91-201 – Explosives Safety Standards
 - AFI 31-101 – The Physical Security Program
 - DoD 6055.9 STD – DoD Ammunition and Explosives Safety Standards

ARCHIVED

Please see the next page.



Figure 4.3
IMF -
Barksdale AFB, LA

4.2.2 Category Code 212-212 Missile Assembly Shop/Integrated Maintenance Facility (IMF)

This facility is used to prepare and transfer standoff missiles for operational use, organizational maintenance of components and subsystem replacement, and bench-level maintenance support for missile components. It also supports electrical testing and the evaluation of individual missiles and empty/loaded launcher systems. Restrooms and break area are typically included in this facility.

Functions performed in this facility require drive-through maintenance bays. Drive-through work bays should have a smooth approach and apron area. The vehicle circulation layout within the munitions storage area (MSA) should provide easy access to and from this building.

4.2.2.1 Facility-Specific Construction Requirements

1. Interior dividing walls should be a minimum of 12 inches (in) (304.8 millimeter (mm)) thick reinforced concrete. Dividing walls between operating bays should have a compressive strength of 2,500 pounds per square inch gauge (psig) (17,170 kilo Pascals (kPa)). See [TM 5-1300/AFM 88-22](#), *Structures to Resist the Effects of Accidental Explosions*, for more information on constructing substantial dividing walls.

Check with the base WSM in the early phase of facility planning and requirements in [AFMAN 91-201](#) for concurrent operations interpretations by the MAJCOMs.

2. Maintenance bay floors should be of sufficient compression strength to accommodate missile system and related support equipment.

4.2.2.2 Facility-Specific Spatial Requirements

1. Space requirements for each weapon system are unique and are determined during the weapon system acquisition process.
2. Provide space for a hydraulic power unit as required for the type of weapon system assembled and maintained in the facility.

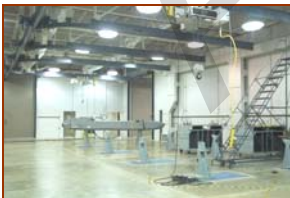

Figure 4.4
IMF Work Bay -
Barksdale AFB, LA

4.2.2.3 Facility-Specific Mechanical Requirements

Missile maintenance operations may generate fuel and solvent vapors that need to be removed from the facility. Size and capacity of the ventilation system will be determined in consultation with base Bio-Environmental. The ventilation requirements will be based upon function and operation of the facility.

1. Comply with fuel vapor emission criteria as required by [AFI 32-7040](#), *Air Quality Compliance*.



2. HVAC requirements for office areas must comply with requirements defined in Chapter 3, “General Design Guidance.”

4.2.2.4 Facility-Specific Electrical Requirements

1. Provide a back-up generator for uninterrupted power supply to allow continuous, explosives maintenance operations (e.g., missile testing, pylon loading, intrusion detection, etc.).
2. Provide grounding, surge protection, and LPS.
3. Provide explosion-proof lighting fixtures if facility is classified as a Class I explosive fuel/vapor hazard facility.
4. May require 120 volts alternating current (VAC), 400 Hertz (Hz), 3-phase power dependent on assigned missile systems as described in [TM 5-811](#) and [AFMAN 91-201](#).

4.2.2.5 Other Specific Requirements

1. Provide overhead transverse-mounted hoist as required for the type of weapon system assembled and maintained in the facility.
2. Shops must have low-pressure air, 0 to 150 psig (0 to 1,030 kPa), and high-pressure air, 0 to 3,500 psig (0 to 24,100 kPa), in all bays.



Location: Barksdale AFB, Louisiana
Command: ACC
Facility Number: 7445
Date Constructed: 2001

Facility Overview

This facility is used to transfer and prepare standoff missiles for operational use, performing unit level maintenance involving component and sub-system replacement, and performing bench checks on components.

Design

- Large unobstructed bays
- Flow-through capability on high bay
- Excellent interior lighting in work bays
- Generators installed in facility for specialized power needs
- High powered hoist systems to support assigned munitions
- Large surrounding apron to support GOV and MMHE usage
- IMF protected by catenary lightning protection system



Missile Assembly Shop and IMF



High Bay Maintenance and Assembly Space

Space Usage

Size (Total) 34,000 sq ft (3,158.70m²)

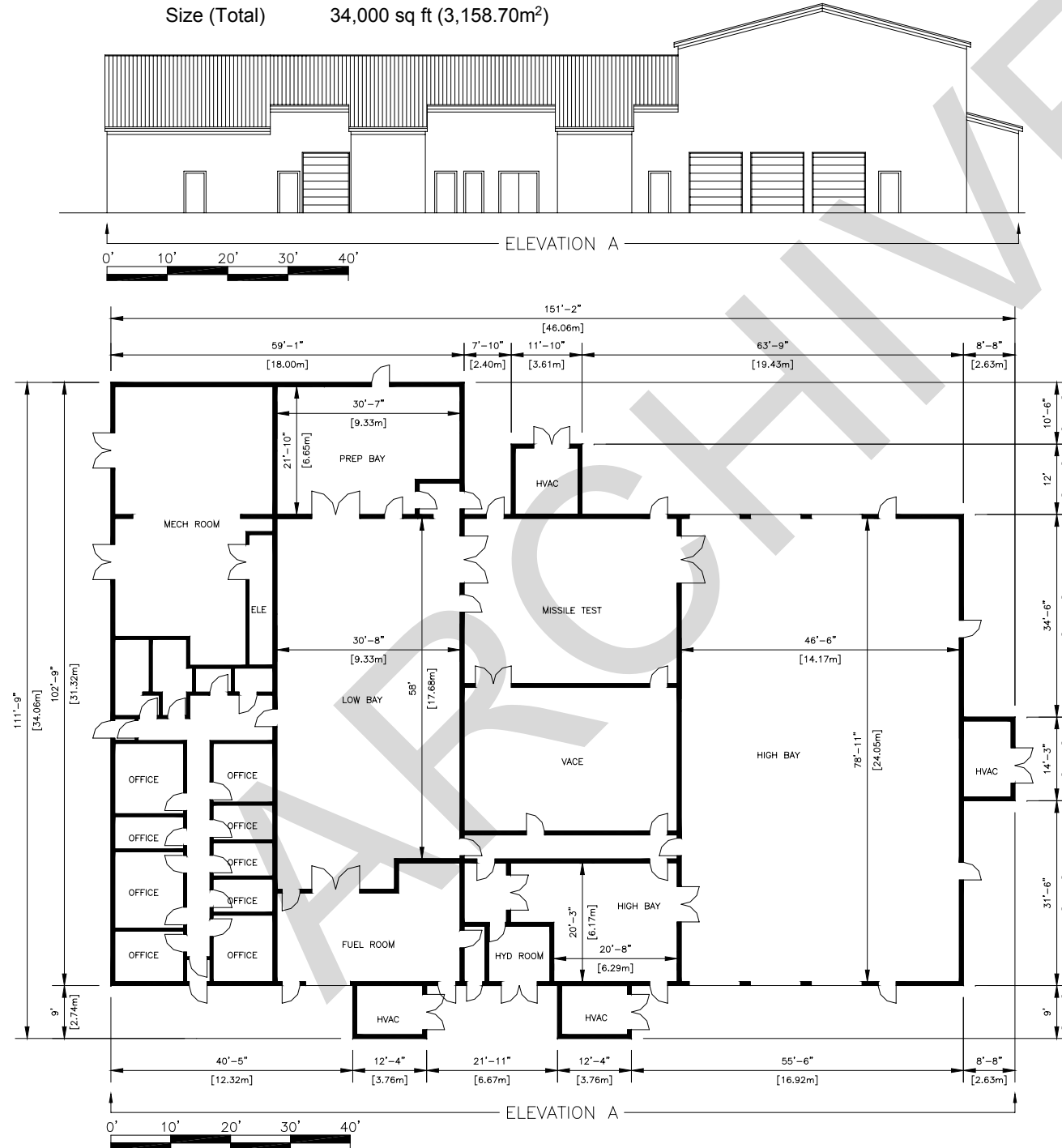

Facility Elevation

Facility Floor Plan

Category Code 212-212

Missile Assembly Shop/Integrated Maintenance Facility (IMF)

Design Related to Aircraft Type

Aircraft Type: Bomber
 Primary Aircraft: B-52

Stand Alone Facility

Consolidated Facility
 Other Uses:

Single Wing

Multiple Wings

Structural	<ul style="list-style-type: none"> • Work bay size dependent upon assigned missile(s) • Provide drive-through bays with roll-up doors • Provide 12 in (304.8mm) thick reinforced interior concrete dividing walls 2,500 psig (17,170 kPa) • Design exterior apron/pavement and composition to accommodate missile system and MMHE • Provide latrine facilities for assigned personnel • Tool, supply, bench stock, and equipment room sizes dependent on assigned missile system(s) • Provide a 1,500 sq ft (137 m²) administration area
Electrical	<ul style="list-style-type: none"> • May require 120 VAC, 400 Hz, 3-phase power • Provide UL-approved lighting in areas where explosives vapor or dust hazard are not present • Provide explosive-proof lights per AFMAN 91-201 • Provide emergency power generator(s) • Electrical service to the building per AFMAN 91-201 and NFPA 780
Fire/Safety	<ul style="list-style-type: none"> • Provide lightning and surge protection per NFPA 780, MIL HDBK 419, and AFMAN 91-201 • Provide grounding system per AFI 32-1065 • Provide blast-resistant windows as needed • Provide ventilation/exhaust systems per AFI 32-7040 • Exhaust fans required for each work bay • Provide outward-opening emergency exit doors
Force Protection	<ul style="list-style-type: none"> • Install exterior security lighting based on local threat assessment
Equipment	<ul style="list-style-type: none"> • Provide overhead transverse-mounted crane/hoist with 4,000-lb (1,810 kg) capacity • Provide hydraulic unit(s) as required • Provide compressed air; low pressure 0 to 150 psig (0 to 1,030 kPa) and high pressure 0 to 3,500 psig (0 to 24,100 kPa) in all bays

Other References:

- AFH 32-1084 – *Facilities Requirements*
- AFMAN 91-201 – *Explosives Safety Standards*
- AFI 31-101 – *The Physical Security Program*
- DoD 6055.9 STD – *DoD Ammunition and Explosives Safety Standards*

ARCHIVED

Please see the next page.



Figure 4.5
Tactical Missile/Glide
Weapon Maintenance
Shop -
Barksdale AFB, LA



Figure 4.6
Tactical Missile/Glide Weapon
Maintenance Shop -
Luke AFB, AZ

4.2.3

Category Code 212-213

Tactical Missile/Glide Weapon Maintenance Shop

Missile and glide munitions assembly and disassembly inspections, testing, and repairs are accomplished in this facility. The facility consists of individual drive-through work bays, a test cell room for electrical and resistance checks of rocket motors, a tool and test equipment support room, and a supply and equipment storage area. Restrooms and a break area are typically included in this facility. An administrative area for office space and a ready/training room are also included, but separated from the shop area by a substantial dividing wall. The drive-through work bays should have a smooth approach and apron area.

4.2.3.1 Facility-Specific Construction Requirements

Interior dividing walls should be a minimum of 12 in (304.8 mm) thick reinforced concrete. Dividing walls between operating bays should have a compressive strength of 2,500 psig (17,170 kPa). Propagation protection for other maintenance operations should be provided between operating bays as outlined for concurrent operations in [AFMAN 91-201](#) and [TM 5-1300/AFM 88-22](#).

Check with the WSM in the early phase of facility planning for concurrent operations interpretations by the MAJCOMs that may inhibit the ability to perform multiple operations in a facility.

4.2.3.2 Facility-Specific Spatial Requirements

Separate facilities should be provided to support missiles involving different explosives hazards, (e.g. fragmentation, extreme heat, mass detonation).

This facility requires a minimum of one work bay per assigned missile type. Each work bay is typically 30 feet (ft) x 50 ft (9.1 meter (m) x 15.2 m), depending upon workload. For example, a facility with three work bays could have one bay for air-to-air missile systems, one for air-to-ground missiles, and one for glide weapon systems.

An adjoining administrative area consists of about 1,500 square feet (sq ft) (137 meters squared (m²)).

A test cell room may be required for rocket motor electrical and resistant checks.

4.2.3.3 Facility-Specific Mechanical Requirements

1. Provide a ventilated paint spray booth, if required.
2. Comply with fuel vapor and paint vapor criteria as required by [AFI 32-7040](#).



3. Environmental controls for humidity and temperature are required to assure proper protection for weapon systems and test equipment.
4. HVAC requirements for office and bay areas must comply with requirements defined in Chapter 3, "General Design Guidance."



Figure 4.7
Tactical Missile/Glide Weapon
Maintenance Shop -
Langley AFB, VA

4.2.3.4 Facility-Specific Electrical Requirements

1. Provide grounding, surge protection, and LPS.
2. Shops must have 115 VAC, 60 Hz, single-phase and 115 VAC, 400 Hz, 3-phase electricity as described in [TM 5-811](#) and [AFMAN 91-201](#).

4.2.3.5 Other Specific Requirements

1. Provide high security hasps on all bay doors with an intrusion detection system as required by [AFI 31-101](#), *The Air Force Installation Security Program* (For Official Use Only (FOUO)).
2. The shop requires a 4,000-pound (lb) (1,810 kilogram (kg)) transverse-mounted hoist in each bay.
3. All bay doors are a minimum 10 ft (3 m) high and 17 ft (5 m) wide.
4. The shop may need a drive-through paint spray booth that complies with environmental standards.
5. Shops must have low-pressure air, 0 to 150 psig (0 to 1,030 kPa), and high-pressure air, 0 to 3,500 psig (0 to 24,100 kPa), in all bays.



Location: Barksdale AFB, Louisiana
Command: ACC
Facility Number: 7700
Date Constructed: 1998

Facility Overview

Facility is used to perform missile assembly and disassembly inspections, testing, and repair on the AGM-142, AGM-154, AGM-84, and AGM-158 systems. These operations are performed in two drive-through bays.

Design

- Two work bays separated by administrative space
- Flow-through access
- Large rollup doors for munitions entry/exit

Space Usage
 Size (Total) 5,895 sq ft (547.66m²)



Administrative and Maintenance Space Inside Security Fence



Large Maintenance Bay with Roll-up and Personnel Doors



Facility Elevation

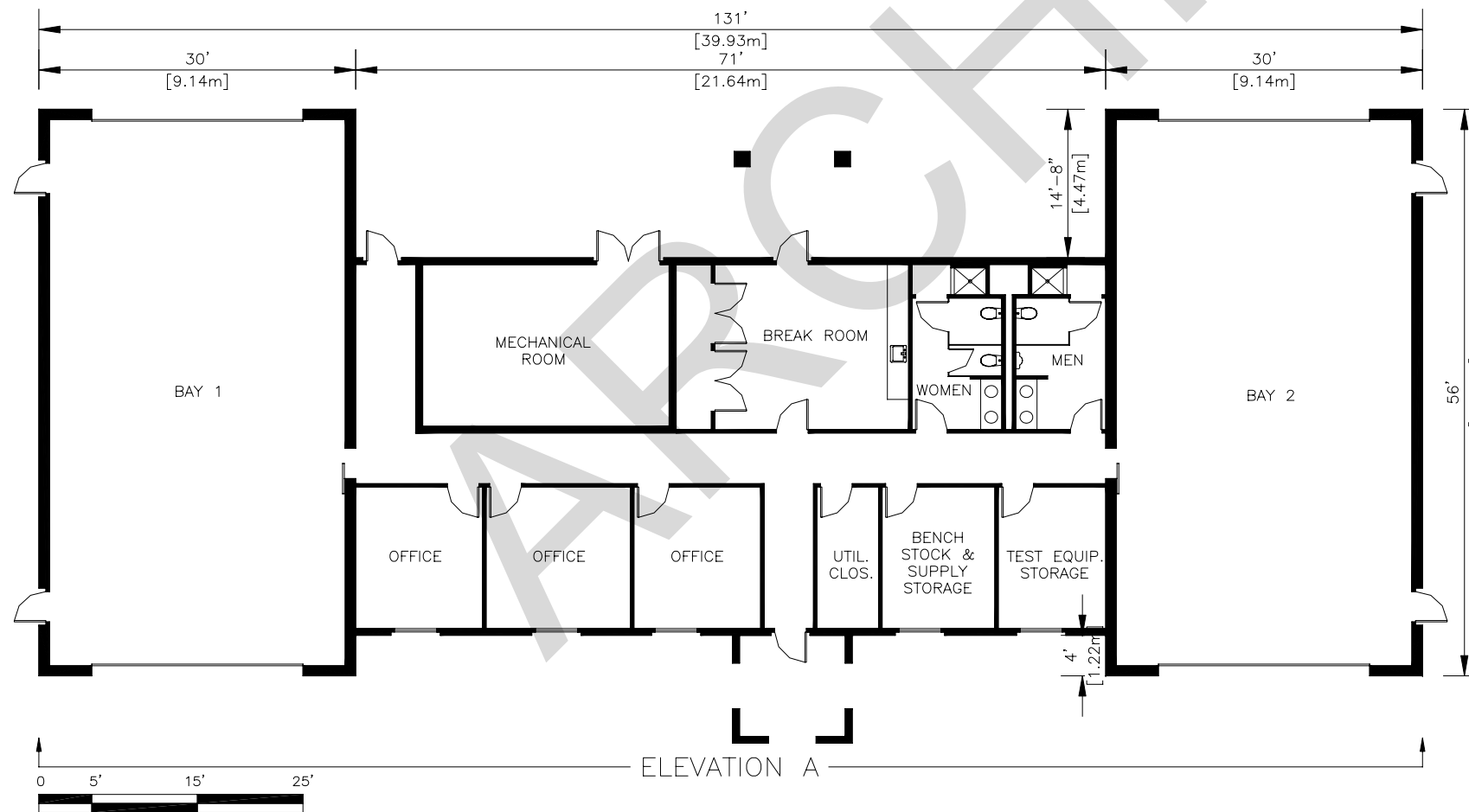

Facility Floor Plan

Category Code 212-213
Tactical Missile/Glide Weapon
Maintenance Shop

Design Related to Aircraft Type
 Aircraft Type: Bomber
 Primary Aircraft: B-52

Stand Alone Facility
 Consolidated Facility
 Other Uses:

Single Wing
 Multiple Wings

Structural

- Provide two 30 ft (9.10m) wide x 50 ft (15.20m) long work bays
- Provide drive-through bays with a minimum door size of 10 ft (3.00m) high x 17 ft (5.18m) wide
- Provide 12 in (304.80mm) thick reinforced interior concrete dividing walls 2,500 psig (17,170 kPa)
- Design exterior apron/pavement and composition to accommodate missile system and MMHE
- Provide latrine facilities for assigned personnel
- Tool, supply, bench stock, and equipment room sizes dependent on assigned missile system(s)
- Provide a 1,500 sq ft (137.00m²) administration area

Electrical

- Provide 115 VAC, 60 Hz, single phase power and 115 VAC, 400 Hz, 3-phase power
- Provide emergency power generator(s)
- Electrical service to the building per AFMAN 91-201 and NFPA 780

Fire/Safety

- Provide lightning and surge protection per NFPA 780, MIL HDBK 419, and AFMAN 91-201
- Provide grounding system per AFI 32-1065
- Provide blast-resistant windows as needed
- Provide ventilation/exhaust systems per AFI 32-7040
- Provide outward-opening emergency exit doors

Force Protection

- Provide high security hasps and intrusion detection system per AFI 31-101
- Install exterior security lighting based on local threat assessment

Equipment

- Provide overhead transverse-mounted crane/hoist with 4,000-lb (1,810 kg) capacity
- Provide paint booth if required
- Provide compressed air; low pressure 0 to 150 psig (0 to 1,030 kPa) and high pressure 0 to 3,500 psig (0 to 24,100 kPa) in all bays

Other References:

- AFH 32-1084 – Facilities Requirements
- AFMAN 91-201 – Explosives Safety Standards
- AFI 31-101 – The Physical Security Program
- DoD 6055.9 STD – DoD Ammunition and Explosives Safety Standards

ARCHIVED

Please see the next page.

Location: Eglin AFB, Florida
Command: ACC (tenant)
Facility Number: 1280
Date Constructed: 2003

Facility Overview

Facility is used to perform missile assembly and disassembly inspections, testing, and repair on AIM-7, AIM-9, and AIM-120 air-to-air missile systems, as well as the AGM-65 air-to-ground missile system.

Design

- Four work bays and attached administrative space
- One bay is a ready missile holding area
- All bays have multiple air and electrical outlets and transverse mounted hoists
- Large surrounding apron to support GOV and MMHE usage.

Space Usage

Size (Total) 14,012 sq ft (1,301.76m²)



Drive-through Maintenance Bays



Hoist System

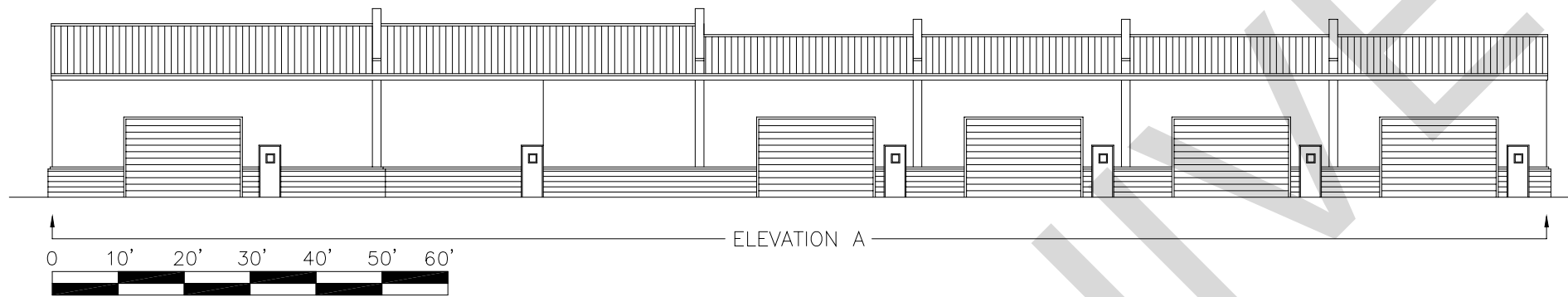

Facility Elevation

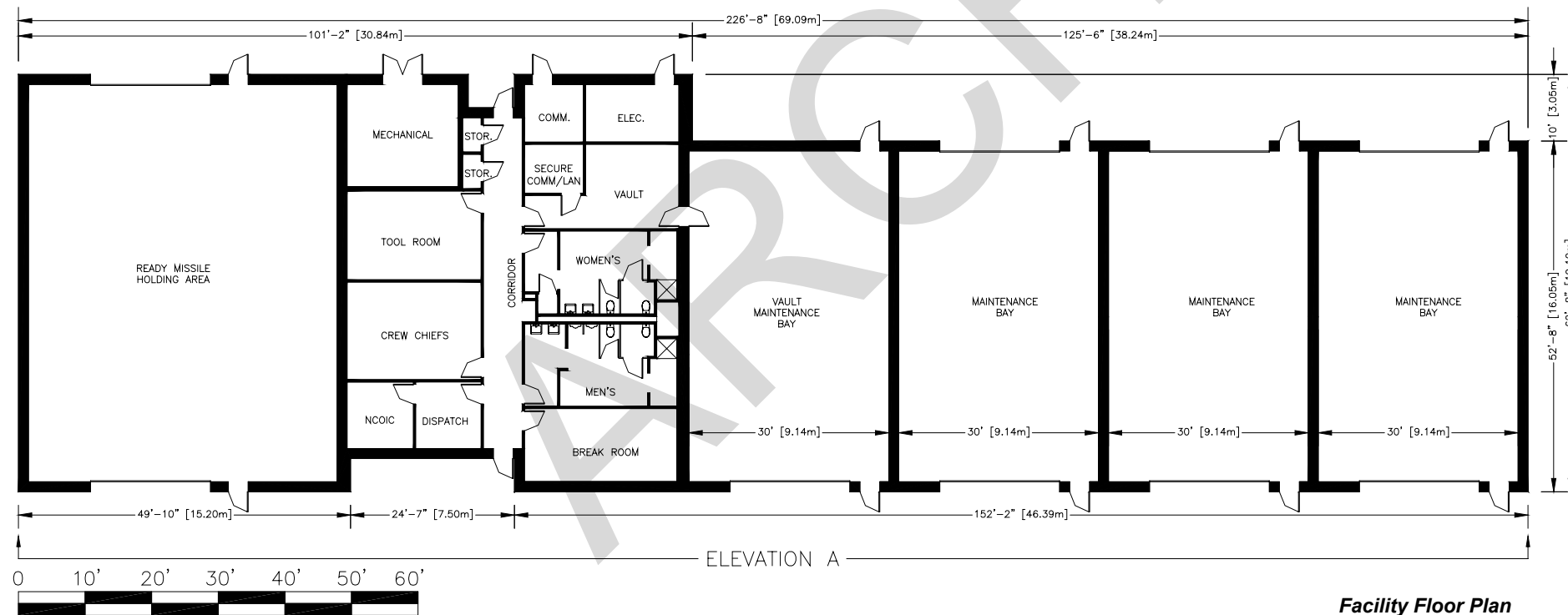

Facility Floor Plan

Category Code 212-213
Tactical Missile/Glide Weapon
Maintenance Shop

Design Related to Aircraft Type

Aircraft Type: Multiple
 Primary Aircraft: Multiple

Stand Alone Facility

Consolidated Facility
 Other Uses:

Single Wing

Multiple Wings

Structural

- Provide a minimum of three 30 ft (9.1m) wide x 50 ft (15.2 m) long work bays to support assigned missile systems. Not in AFH 32-1084.
- Provide drive-through bays with a minimum door size of 10 ft (3m) high x 17 ft (5.2m) wide
- Provide 12 in (304.8mm) thick reinforced interior concrete dividing walls 2,500 psig (17,170 kPa)
- Design exterior apron/pavement and composition to accommodate missile system and MMHE
- Provide latrine facilities for assigned personnel
- Tool, supply, bench stock, and equipment room sizes dependent on assigned missile system(s)
- Provide a 1,500 sq ft (137m²) administration area

Electrical

- Provide 115 VAC, 60 Hz, single phase power and 115 VAC, 400 Hz, 3-phase power
- Provide emergency power generator(s)
- Electrical service to the building per AFMAN 91-201 and NFPA 780

Fire/Safety

- Provide lightning and surge protection per NFPA 780, MIL HDBK 419, and AFMAN 91-201
- Provide grounding system per AFI 32-1065
- Provide blast-resistant windows as needed
- Provide ventilation/exhaust systems per AFI 32-7040
- Provide outward-opening emergency exit doors

Force Protection

- Provide high security hasps and intrusion detection system per AFI 31-101
- Install exterior security lighting based on local threat assessment

Equipment

- Provide overhead transverse-mounted crane/hoist with 4,000-lb (1,810 kg) capacity
- Provide paint booth if required
- Provide compressed air; low pressure 0 to 150 psig (0 to 1,030 kPa) and high pressure 0 to 3,500 psig (0 to 24,100 kPa) in all bays

Other References:

- AFH 32-1084 – *Facilities Requirements*
- AFMAN 91-201 – *Explosives Safety Standards*
- AFI 31-101 – *The Physical Security Program*
- DoD 6055.9 STD – *DoD Ammunition and Explosives Safety Standards*

ARCHIVED

Please see the next page.

Location: Luke AFB, Arizona
Command: AETC
Facility Number: 1245, 1246
Date Constructed: 1995

Facility Overview

Facility is used to perform missile assembly and disassembly inspections, testing, and repair on AIM-7, AIM-9, and AIM-120 air-to-air missile systems, as well as the AGM-65 air-to-ground missile system. The layout illustrated below is a composite of buildings 1245 and 1246.

Design

- Three work bays and attached administrative space
- Drive-through access
- Large roll-up doors for vehicle/trailer entry/exit
- Three phase, 400Hz generator installed in facility
- Electric hoists in bays

Space Usage

Size (Total) 6,800 sq ft (631.74m²)



Drive-through Maintenance Bays and Storage Pad



Maintenance Bay with Roll-up Door

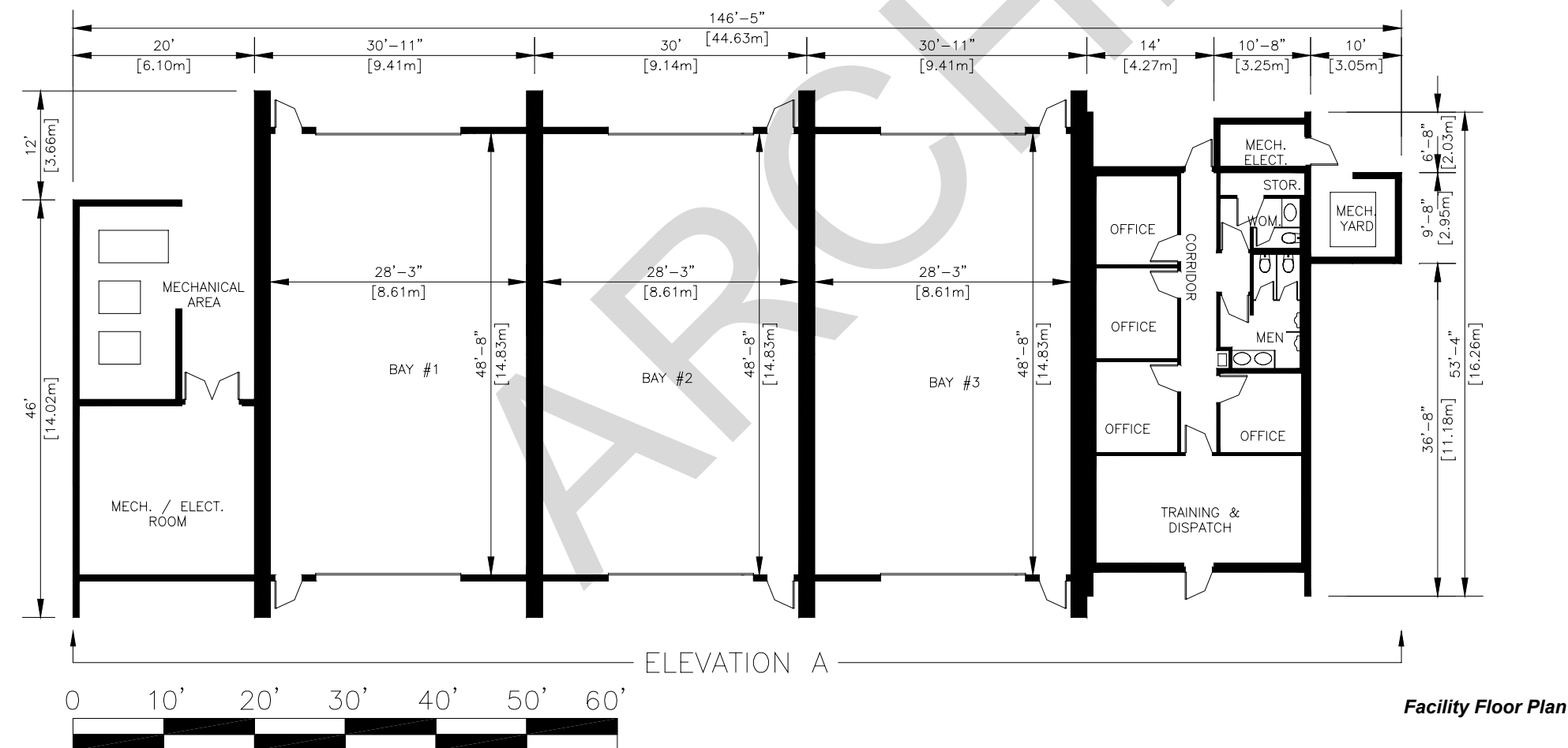

Category Code 212-213
Tactical Missile/Glide Weapon
Maintenance Shop

Design Related to Aircraft Type

Aircraft Type: Fighter
 Primary Aircraft: F-16

Stand Alone Facility

Consolidated Facility
 Other Uses:

Single Wing

Multiple Wings

Structural

- Provide a minimum of three 30 ft (9.1m) wide x 50 ft (15.2 m) long work bays to support assigned missile systems. Not in AFH 32-1084.
- Provide drive-through bays with a minimum door size of 10 ft (3.00m) high x 17 ft (5.18m) wide
- Provide 12 in (304.80mm) thick reinforced interior concrete dividing walls 2,500 psig (17,170 kPa)
- Design exterior apron/pavement and composition to accommodate missile system and MMHE
- Provide latrine facilities for assigned personnel
- Tool, supply, bench stock, and equipment room sizes dependent on assigned missile system(s)
- Provide a 1,500 sq ft (137m²) administration area

Electrical

- Provide 115 VAC, 60 Hz, single phase power and 115 VAC, 400 Hz, 3-phase power
- Provide emergency power generator(s)
- Electrical service to the building per AFMAN 91-201 and NFPA 780

Fire/Safety

- Provide lightning and surge protection per NFPA 780, MIL HDBK 419, and AFMAN 91-201
- Provide grounding system per AFI 32-1065
- Provide blast-resistant windows as needed
- Provide ventilation/exhaust systems per AFI 32-7040
- Provide outward-opening emergency exit doors

Force Protection

- Provide high security hasps and intrusion detection system per AFI 31-101
- Install exterior security lighting based on local threat assessment

Equipment

- Provide overhead transverse-mounted crane/hoist with 4,000-lb (1,810 kg) capacity
- Provide paint booth if required
- Provide compressed air; low pressure 0 to 150 psig (0 to 1,030 kPa) and high pressure 0 to 3,500 psig (0 to 24,100 kPa) in all bays

Other References:

- AFH 32-1084 – *Facilities Requirements*
- AFMAN 91-201 – *Explosives Safety Standards*
- AFI 31-101 – *The Physical Security Program*
- DoD 6055.9 STD – *DoD Ammunition and Explosives Safety Standards*

ARCHIVED

Please see the next page.



Figure 4.8
Weapons and Release
System Shop -
Cannon AFB, NM

4.2.4 Category Code 215-552 Weapons and Release Systems Shop

Overhaul and repair of aircraft weapons release and gun systems including bomb racks, weapons pylons, and ejection racks are accomplished in this facility. The facility also includes a gun and/or ejector unit cleaning room, maintenance offices, a dispatch office, a bench stock room, and storage space for test equipment, alternate mission equipment (AME), spare gun systems, and mobility equipment. Restrooms and a break area are authorized for this facility.

4.2.4.1 Facility-Specific Construction Requirements

If supporting B-1 aircraft, floor must support 50,000 lb. (22,800 kg) with a 250 psig (1,720 kPa) tire footprint.

4.2.4.2 Facility-Specific Spatial Requirements

1. The space requirement for aircraft not equipped with multiple ejector racks (MER) is 10,530 sq ft (980 m²).
2. The space requirement for aircraft equipped with MER is 11,500 sq ft (1,070 m²).
3. The space required for 12 Primary Authorized Aircraft (PAA) B-52 units is 6,000 sq ft (550 m²) and 5,000 sq ft (460 m²) for each additional 12 PAA.
4. The space required for 12 PAA B-1 units is 5,000 sq ft (460 m²) and 3,000 sq ft (275 m²) for each additional 12 PAA.
5. For aircraft with gun systems installed, the shop requires a vault for gun maintenance and spare gun storage.
6. Allow 650 sq ft (60 m²) for administrative space.
7. Additional space may be provided for the storage of mobility-support equipment in high-threat areas.
8. Provide space for storage of AME.

4.2.4.3 Facility-Specific Mechanical Requirements

1. Consult with base Bio-Environmental for the requirements to provide adequate ventilation for the weapons systems cleaning room.
2. Comply with emission criteria as required by [AFI 32-7040](#), the Uniform Building Code (UBC), and [Occupational Safety and Health Administration \(OSHA\)](#) requirements.
3. HVAC requirements for office and bay areas must comply with requirements defined in Chapter 3, "General Design Guidance."



Figure 4.9
Weapons and Release
System Shop -
Luke AFB, AZ



4.2.4.4 Facility-Specific Electrical Requirements

1. Provide 115 VAC, 60 Hz, single-phase and surge protection as described in [TM 5-811](#) and [AFMAN 91-201](#).
2. Explosion-proof light fixtures may be required in the maintenance bays if a Class I (explosive fuel/vapor) or Class II (explosive dust) hazard will be encountered.
3. Consult the users for special electrical requirements of test equipment.
4. Provide grounding, surge protection, and LPS.

4.2.4.5 Other Specific Requirements

1. A 10-ton (9,070 kg) monorail hoist is required for facilities supporting B-52 aircraft tasked with heavy stores/MER beams and cluster racks.
2. For facilities supporting the B-1B aircraft, a 10-ton (9,070 kg) monorail hoist is required.
3. For facilities supporting B-1 aircraft, a minimum 12 ft x 12 ft (3.65 m x 3.65 m) overhead doors are required for drive-through bays.
4. If located within the explosives clear zone, the facility must be included in the explosives site plan. If located outside the explosives clear zone and explosives items are removed from the system and stored in the facility, an explosives license is required. [DoD 6055.9 STD](#) and [AFMAN 91-201](#) outline explosives safety and siting/licensing requirements.



Location: Cannon AFB, New Mexico
Command: ACC
Facility Number: 122
Date Constructed: 1991

Facility Overview

This facility provides space for testing, overhaul, and repair of aircraft release and gun systems and their respective support equipment. Space is also provided for storage of Alternate Mission Equipment (AME), spare guns, and mobility assets. A vault is included for security of the M61 aircraft gun system. The original design was for the F-111 weapons release systems.

Design

- High ceiling work bays with overhead lift
- Large roll-up doors for vehicle/trailer entry/exit
- Two work bays totaling 11,500 sq ft (1,068.39m²)

Space Usage

Size (Total) 31,600 sq ft (2,935.74m²)



Entrance to Administration and Shop Space



Sufficient Ceiling Height for Vertical Storage

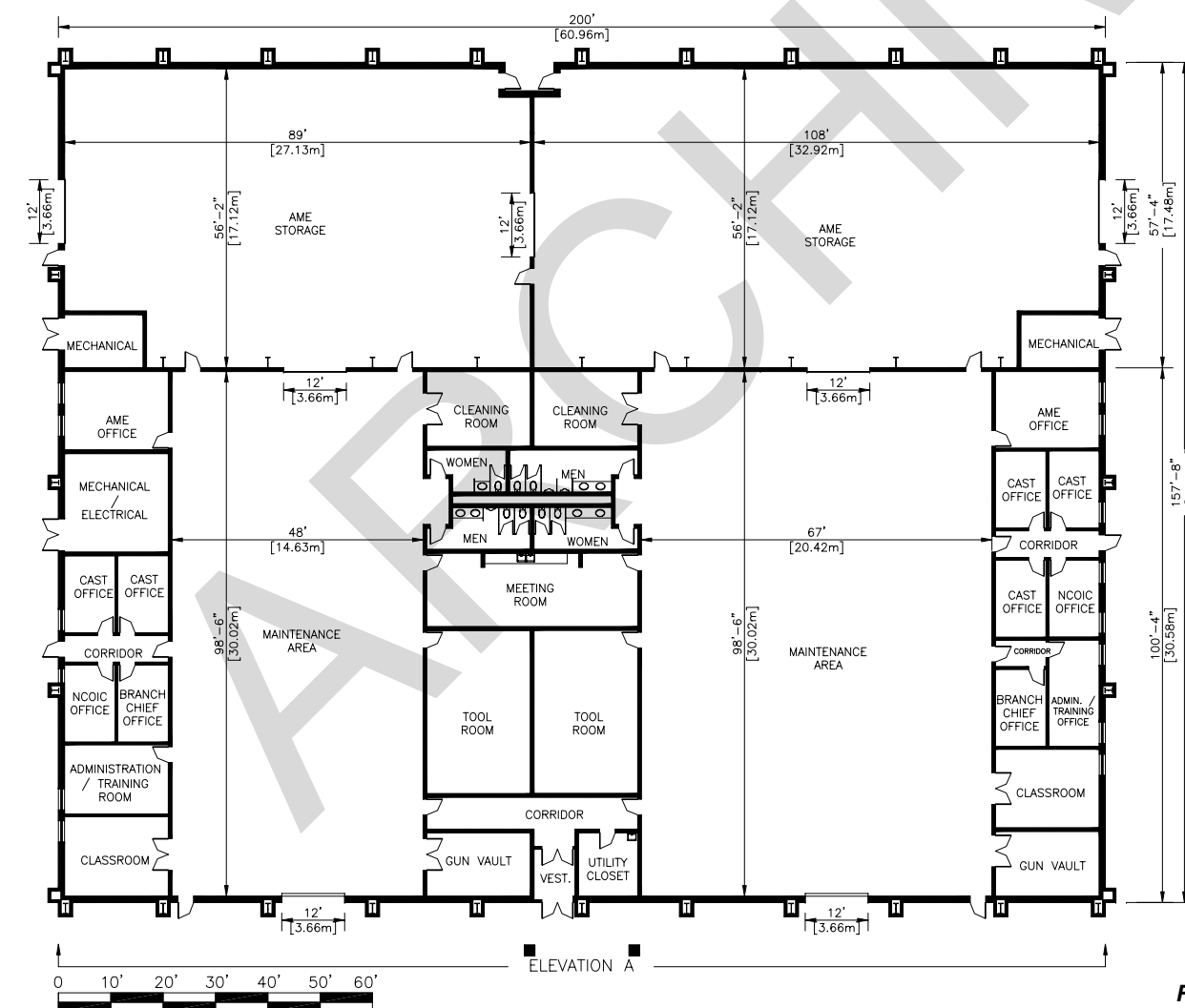
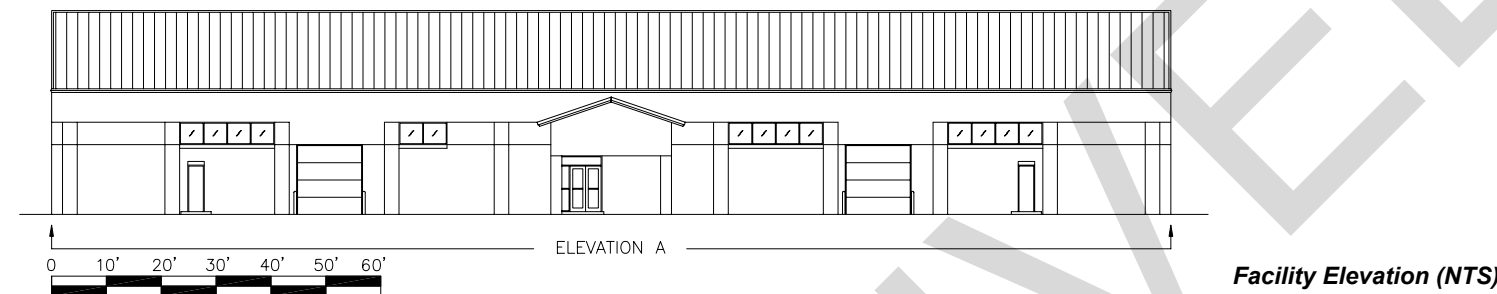

Category Code 215-552
Weapons and Release Systems Shop

Design Related to Aircraft Type
 Aircraft Type: Fighter
 Primary Aircraft: F-16

Stand Alone Facility
 Consolidated Facility
 Other Uses:

Single Wing
 Multiple Wings

Structural

- Provide work space based on assigned aircraft, weapons release and gun systems per AFH 32-1084.
- Provide drive-through bays with roll-up doors minimum 12 ft (3.65m) wide x 12 ft (3.65m) high
- Design exterior apron/pavement and composition to accommodate release and gun systems and MMHE
- Provide latrine facilities for assigned personnel
- Tool, supply, bench stock, and equipment room sizes dependent on assigned releaser and gun systems
- Provide a 1,500 sq ft (137m²) administration area

Electrical

- Provide 120 and 220 VAC, 60 Hz, single phase power and 115 VAC, 400 Hz, 3-phase power (special power may be required)
- Provide emergency power generator(s)
- Electrical service to the building per AFMAN 91-201 and NFPA 780 (as applicable)

Fire/Safety

- Provide lightning and surge protection per NFPA 780, MIL HDBK 419, and AFMAN 91-201
- Provide grounding system per AFI 32-1065
- Provide blast-resistant windows as needed
- Provide ventilation/exhaust systems per AFI 32-7040
- Provide emergency exit doors per AFMAN 91-201(as applicable)

Force Protection

- Provide high security hasps and intrusion detection system per AFI 31-101(if required)
- Install exterior security lighting based on local threat assessment

Equipment

- Provide overhead transverse-mounted crane/hoist with 4,000-lb (1,810 kg) capacity
- Provide paint booth (if required)
- Provide compressed air; low pressure 0 to 150 psig (0 to 1,030 kPa) and high pressure 0 to 3,500 psig (0 to 24,100 kPa) in all bays

Other References:

- AFH 32-1084 – Facilities Requirements
- AFMAN 91-201 – Explosives Safety Standards
- AFI 31-101 – The Physical Security Program
- DoD 6055.9 STD – DoD Ammunition and Explosives Safety Standards

ARCHIVED

Please see the next page.

Location: Luke AFB, Arizona
Command: AETC
Facility Number: 920
Date Constructed: 1958

- Design**
- Colocated administrative space
 - Large high ceiling bays accommodate equipment and weapon systems
 - Large roll-up doors for vehicle/trailer entry/exit

Space Usage
 Size (Total) 31,600 sq ft (2,935.74m²)



Break Area



Colocated Administrative Space

Facility Overview

This facility provides space for testing, overhaul, and repair of aircraft release and gun systems and their respective support equipment. Space is also provided for storage of Alternate Mission Equipment (AME), spare guns, and mobility assets. A vault is included for security of the M61 aircraft gun system.

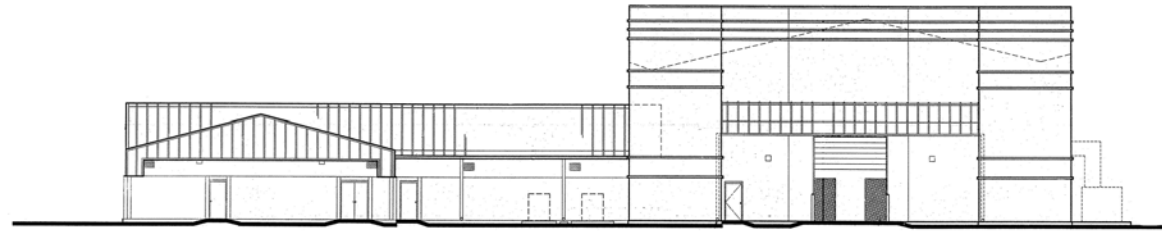

Facility Elevation (NTS)

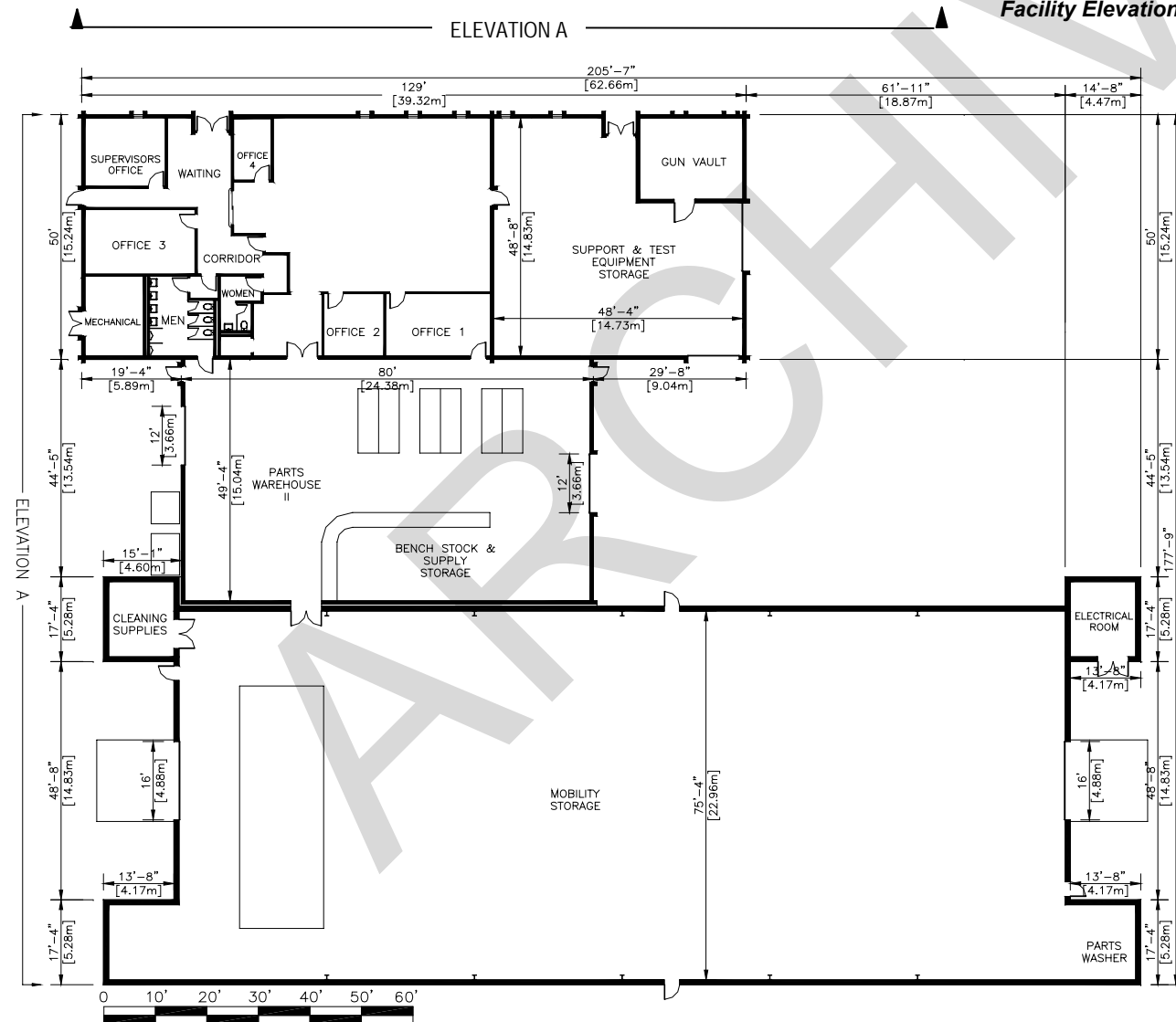

Facility Floor Plan

Category Code 215-552
Weapons and Release Systems Shop

- Design Related to Aircraft Type**
 Aircraft Type: Fighter
 Primary Aircraft: F-16

- Stand Alone Facility**
 Consolidated Facility
 Other Uses:

- Single Wing**
 Multiple Wings

Structural	<ul style="list-style-type: none"> • Provide work space based on assigned aircraft, weapons release and gun systems per AFH 32-1084. • Design exterior apron/pavement and composition to accommodate release and gun systems and MMHE • Provide latrine facilities for assigned personnel • Tool, supply, bench stock, and equipment room sizes dependent on assigned releaser and gun systems • Provide a 1,500 sq ft (137m²) administration area
Electrical	<ul style="list-style-type: none"> • Provide 120 and 220 VAC, 60 Hz, single phase power and 115 VAC, 400 Hz, 3-phase power (special power may be required) • Provide emergency power generator(s) • Electrical service to the building per AFMAN 91-201 and NFPA 780 (as applicable)
Fire/Safety	<ul style="list-style-type: none"> • Provide lightning and surge protection per NFPA 780, MIL HDBK 419, and AFMAN 91-201 • Provide grounding system per AFI 32-1065 • Provide blast-resistant windows as needed • Provide ventilation/exhaust systems per AFI 32-7040 • Provide emergency exit doors per AFMAN 91-201 (if applicable)
Force Protection	<ul style="list-style-type: none"> • Provide high security hasps and intrusion detection system per AFI 31-101 (if required) • Install exterior security lighting based on local threat assessment
Equipment	<ul style="list-style-type: none"> • Provide overhead transverse-mounted crane/hoist with 4,000-lb (1,810 kg) capacity • Provide paint booth (if required) • Provide compressed air; low pressure 0 to 150 psig (0 to 1,030 kPa)

- Other References:**
- AFH 32-1084 – *Facilities Requirements*
 - AFMAN 91-201 – *Explosives Safety Standards*
 - AFI 31-101 – *The Physical Security Program*
 - DoD 6055.9 STD – *DoD Ammunition and Explosives Safety Standards*

ARCHIVED

Please see the next page.

Location: Whiteman AFB, Missouri
Command: ACC
Facility Number: 14
Date Constructed: 1991

Facility Overview

This facility provides space for testing, overhaul, and repair of aircraft release and their respective support equipment. Space is provided in another facility for storage of Alternate Mission Equipment (AME), and mobility assets.

Design

- Large unobstructed work bays
- Large roll-up doors for vehicle/trailer entry/exit
- Multiple power and compressed air outlets
- Colocated administrative space
- Second floor provides storage space

Space Usage

Size (Total) 31,600 sq ft (2,935.74m²)
 Category Code (215-552) 10,304 sq ft (957.27m²)
 Category Code (171-875) 21,296 sq ft (1978.46m²)



This Dual-use Facility Houses Load Crew Training (shown on left) with a Weapons Release Shop on the right



Work Bay with Mezzanine Visible in the Background

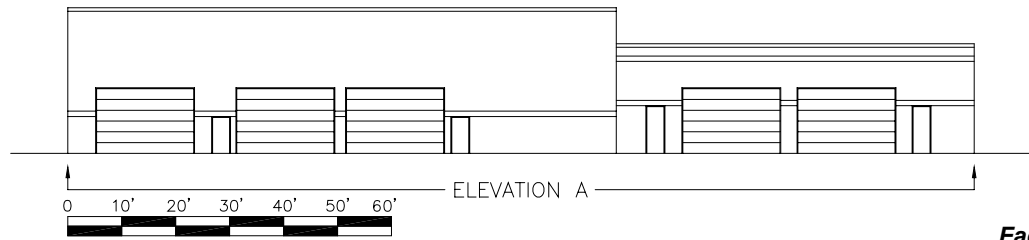

Facility Elevation

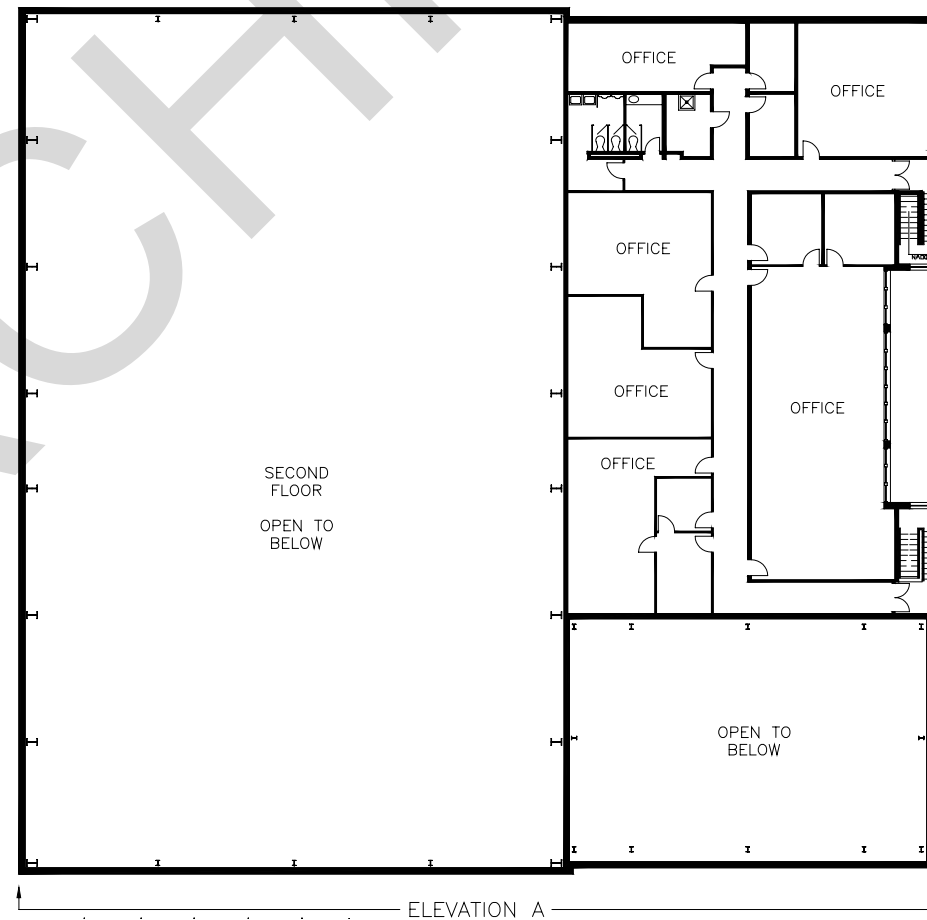
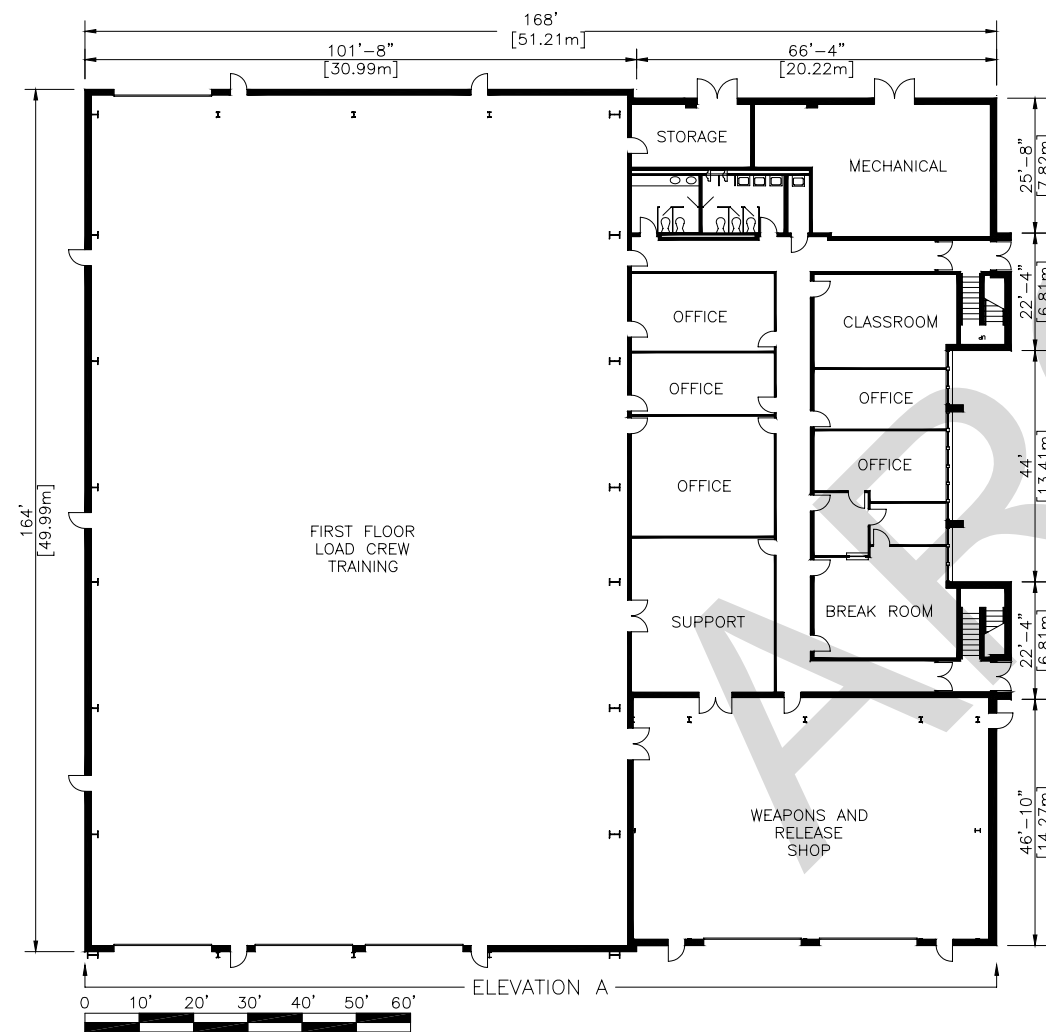

Facility Floor Plan

Category Code 215-552
Weapons and Release Systems Shop

- Design Related to Aircraft Type**
 Aircraft Type: Bomber
 Primary Aircraft: B-2

- Stand Alone Facility**
- Consolidated Facility**
 Other Uses: Load Crew Training Facility (171-875)

- Single Wing**
- Multiple Wings**

Structural

- Provide work space based on assigned aircraft, weapons release and gun systems per AFH 32-1084.
- Provide drive-through bays with a minimum roll-up door size of 12 ft (3.65m) wide x 12 ft (3.65m) high
- Design exterior apron/pavement and composition to accommodate release and gun systems and MMHE
- Provide latrine facilities for assigned personnel
- Tool, supply, bench stock, and equipment room sizes dependent on assigned releaser and gun systems
- Provide a 1,500 sq ft (137.00m²) administration area

Electrical

- Provide 120, 220, and 440 VAC, 60 Hz, single phase power and 115 VAC, 400 Hz, 3-phase power (special power may be required)
- Provide emergency power generator(s)
- Electrical service to the building per AFMAN 91-201 and NFPA 780 (as applicable)

Fire/Safety

- Provide lightning and surge protection per NFPA 780, MIL HDBK 419, and AFMAN 91-201
- Provide grounding system per AFI 32-1065
- Provide blast-resistant windows as needed
- Provide ventilation/exhaust systems per AFI 32-7040
- Provide emergency exit doors per AFMAN 91-201(as applicable)

Force Protection

- Provide high security hasps and intrusion detection system per AFI 31-101(if required)
- Install exterior security lighting based on local threat assessment

Equipment

- Provide overhead transverse-mounted crane/hoist with 10,000-lb (4,525 kg) capacity
- Provide paint booth (if required)
- Provide compressed air; low pressure 0 to 150 psig (0 to 1,030 kPa) and high pressure 0 to 3,500 psig (0 to 24,100 kPa) in all bays

- Other References:**
- AFH 32-1084 – Facilities Requirements
 - AFMAN 91-201 – Explosives Safety Standards
 - AFI 31-101 – The Physical Security Program
 - DoD 6055.9 STD – DoD Ammunition and Explosives Safety Standards

ARCHIVED

Please see the next page.



Figure 4.10
Surveillance and Inspection
Shop -
Langley AFB, VA



Figure 4.11
Surveillance and Inspection
Shop -
McChord AFB, WA

4.2.5 Category Code 215-582 Surveillance and Inspection Shop

This facility accommodates the initial assembly, inspection, test bench, and minor maintenance of various conventional and non-conventional munitions, and their respective components, to include electro-optical and laser-guided bomb guidance kits. Supervisory or administrative space is required for this facility. Restrooms and a break area are authorized for this facility.

4.2.5.1 Facility-Specific Construction Requirements

Interior dividing walls should be a minimum of 12 in (304.8 mm) thick reinforced concrete. Dividing walls between operating bays should have a compressive strength of 2,500 psig (17,170 kPa). Propagation protection for other surveillance and inspection operations should be provided between operating bays as outlined for concurrent operations in [AFMAN 91-201](#) and [TM 5-1300/AFM 88-22](#).

Check with the base WSM in the early phase of facility planning for concurrent operations interpretations by the MAJCOMs.

4.2.5.2 Facility-Specific Spatial Requirements

Space authorized is dependent on aircraft type assigned per [AFH 32-1084](#).

1. Fighter aircraft require 3,940 sq ft (366 m²).
2. Bomber aircraft require 2,090 sq ft (194 m²).
3. Facility may have more than one work bay.

4.2.5.3 Facility-Specific Mechanical Requirements

1. HVAC requirements for office and bay areas must comply with requirements defined in Chapter 3, "General Design Guidance."
2. Comply with paint vapor criteria as required by [AFI 32-7040](#), if a paint booth is to be installed.

4.2.5.4 Facility-Specific Electrical Requirements

1. Explosion-proof light fixtures may be required in the inspection bays if a Class I (explosive fuel/vapor) or Class II (explosive dust) hazard will be encountered.
2. 115 VAC, 400 Hz, 3-phase power may be required as described in [TM 5-811](#) and [AFMAN 91-201](#).
3. Provide grounding, surge protection, and LPS.



4.2.5.5 Other Specific Requirements

1. Provide crane or hoist as required for the type of weapon systems assembled, maintained, and inspected in the facility. Cranes and hoists may require special safety devices to prevent ignition of explosive vapors and dust, if present.
2. Bay doors are a minimum 10 ft (3 m) high by 16 ft (4.8 m) wide.
3. Bay doors require high security hasps if an intrusion detection system (IDS) is installed.
4. Facility may need low-pressure air, 0-150 psig (0-1,030 kPa).
5. Facility may need a drive-through paint booth with an approved ventilation system.

ARCHIVED



Category Code 215-582

Surveillance and Inspection Shop

Location: Eglin AFB, Florida
Command: ACC (tenant)
Facility Number: 1226
Date Constructed: 1976

Facility Overview

This facility is used to perform initial assembly, bench test, inspection, and minor maintenance of various conventional and non-conventional munitions and their respective components to include electro-optical and laser-guided bomb kits.

Design

- Multiple large, unobstructed work bays
- Dedicated loading/unloading dock for munitions shipments
- Colocated field offices
- Large surrounding apron facilitates movement of vehicles and munitions trailers

Space Usage

Size (Total) 8,832 sq ft (820.53m²)



Exterior View of Surveillance and Inspection Shop

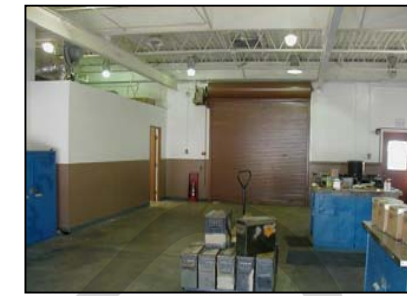

Work Bay

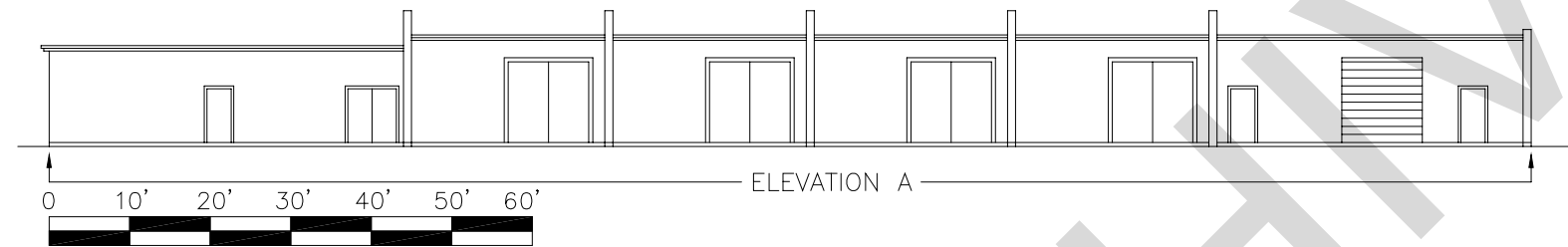

Facility Elevation

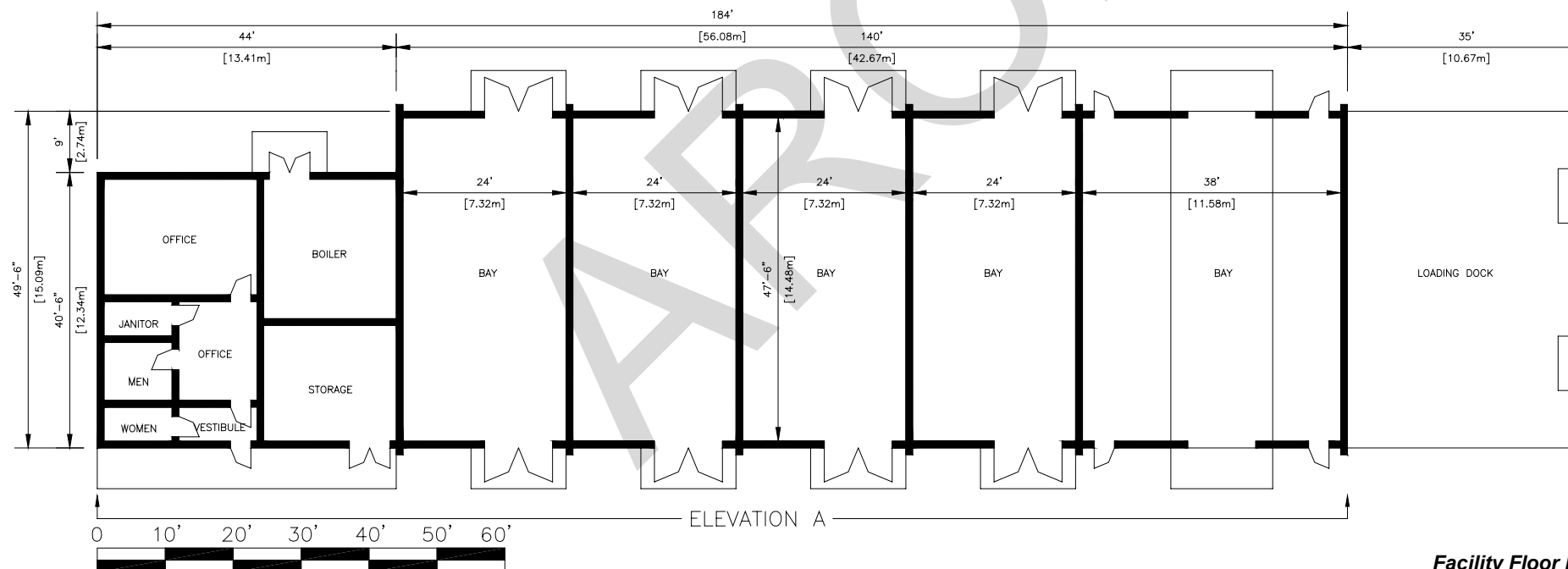

Facility Floor Plan

Design Related to Aircraft Type

Aircraft Type: Multiple
 Primary Aircraft: Multiple

Stand Alone Facility

Consolidated Facility

Other Uses:

Single Wing

Multiple Wings

Structural	<ul style="list-style-type: none"> • Work bay size per AFH 32-1084 • Provide drive-through bays with a minimum roll-up door of 16 ft (4.80m) wide x 10 ft (3.00m) high • Provide 12-inch (304.80mm) thick reinforced interior concrete dividing walls 2,500 psig (17,167 kPa) • Design exterior apron/pavement and composition to accommodate MMHE • Provide latrine facilities for assigned personnel • Provide a 1,500 sq ft (137.00 m²) administration area
Electrical	<ul style="list-style-type: none"> • Provide 115 VAC, 60 Hz, single phase and 115 VAC, 400 Hz, 3-phase power • Provide UL-approved lighting in areas where explosives vapor or dust hazard are not present • Provide explosive-proof lights per AFMAN 91-201 • Provide emergency power generator(s) • Electrical service to the building per AFMAN 91-201 and NFPA 780
Fire/Safety	<ul style="list-style-type: none"> • Provide lightning and surge protection per NFPA 780, MIL HDBK 419, and AFMAN 91-201 • Provide grounding system per AFI 32-1065 • Provide blast-resistant windows as needed • Provide ventilation/exhaust systems per AFI 32-7040 • Use non-combustible material per UFC 3-600-01 • Provide outward-opening emergency exit doors
Force Protection	<ul style="list-style-type: none"> • Install exterior security lighting based on local threat • Provide high security hasps and intrusion detection system per AFI 31-101
Equipment	<ul style="list-style-type: none"> • Provide overhead transverse-mounted crane/hoist with 4,000 lb (1,814.4 kg) capacity or as needed • Provide low pressure compressed air 0 to 150 psig (0 to 1,030 kPa)

Other References:

- AFH 32-1084 – Facilities Requirements
- AFMAN 91-201 – Explosives Safety Standards
- AFI 31-101 – The Physical Security Program
- DoD 6055.9 STD – DoD Ammunition and Explosives Safety Standards

ARCHIVED

Please see the next page.

Category Code 215-582 Surveillance and Inspection Shop

Location: Whiteman AFB, Missouri
Command: AFRC
Facility Number: 1141
Date Constructed: 1995

Facility Overview

This facility is used to perform initial assembly, bench test, inspection, and minor maintenance of various conventional and non-conventional munitions and their respective components to include electro-optical and laser-guided bomb kits.

Design

- Three large unobstructed work bays
- Colocated field offices
- Large surrounding apron to support GOV and MMHE usage
- Flow-through access
- Overhead hoist system in one bay

Space Usage

Size (Total) 4,989 sq ft (463.49m²)
 Category Code 212-213 1,300 sq ft (120.77m²)
 Category Code 216-642 1,368 sq ft (123.12m²)



Wide Apron Provides Easy Access to Drive-thru Bays



Wide Work Bay Provides Adequate Space for Drive-thru Capability

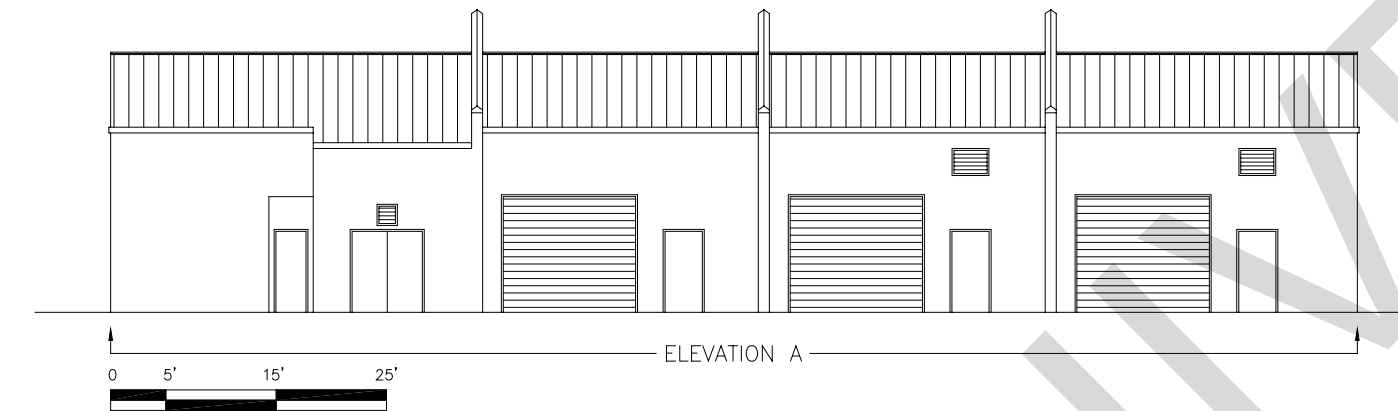

Facility Elevation

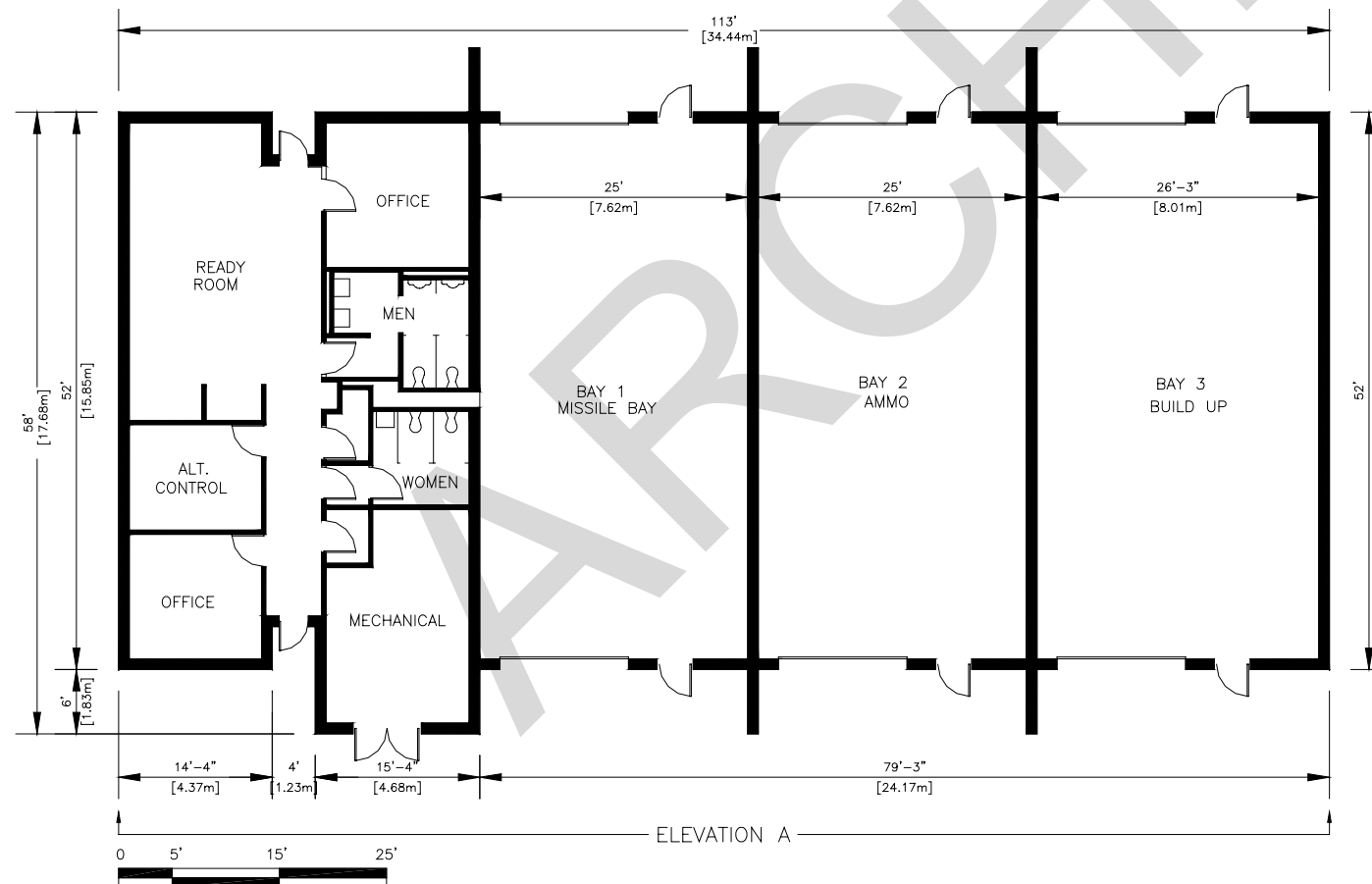

Facility Floor Plan

Design Related to Aircraft Type

Aircraft Type: Fighter
 Primary Aircraft: A-10

Stand Alone Facility

Consolidated Facility

Other Uses: Conventional Munitions Shop (216-642), Tactical Missile/Glide Weapon Shop (212-213)

Single Wing

Multiple Wings

Structural	<ul style="list-style-type: none"> • Work bay size per AFH 32-1084 • Provide drive-through bays with a minimum roll-up door size of 16 ft (4.80 m) wide x 10 ft (3.00m) high • Provide 12-inch (304.80mm) thick reinforced interior concrete dividing walls 2,500 psig (17,167 kPa) between work bays and administrative areas • Design exterior apron/pavement and composition to accommodate MMHE • Provide latrine facilities for assigned personnel • Provide a 1,500 sq ft (137.00 m²) administration area
Electrical	<ul style="list-style-type: none"> • Provide 115 VAC, 60 Hz, single phase and 115 VAC, 400 Hz, 3-phase power • Provide UL-approved lighting in areas where explosives vapor or dust hazard are not present • Provide explosive-proof lights per AFMAN 91-201 • Provide emergency power generator(s) • Electrical service to the building per AFMAN 91-201 and NFPA 780
Fire/Safety	<ul style="list-style-type: none"> • Provide lightning and surge protection per NFPA 780, MIL HDBK 419, and AFMAN 91-201 • Provide grounding system per AFI 32-1065 • Provide blast-resistant windows as needed • Provide ventilation/exhaust systems per AFI 32-7040 • Use non-combustible material per UFC 3-600-01 • Provide outward-opening emergency exit doors
Force Protection	<ul style="list-style-type: none"> • Install exterior security lighting based on local threat • Provide high security hasps and intrusion detection system per AFI 31-101
Equipment	<ul style="list-style-type: none"> • Provide overhead transverse-mounted crane/hoist with 4,000 lb (1,814.4 kg) capacity or as needed • Provide low pressure compressed air 0 to 150 psig (0 to 1,030 kPa)

Other References:

- AFH 32-1084 – Facilities Requirements
- AFMAN 91-201 – Explosives Safety Standards
- AFI 31-101 – The Physical Security Program
- DoD 6055.9 STD – DoD Ammunition and Explosives Safety Standards

ARCHIVED

Please see the next page.



Figure 4.12
Conventional Munitions
Maintenance Shop -
Cannon AFB, NM



Figure 4.13
Conventional Munitions
Maintenance Shop -
Luke AFB, AZ

4.2.6

Category Code 216-642

Conventional Munitions Maintenance Shop

This facility is used to perform maintenance operations including assembly, disassembly, corrosion control, testing and troubleshooting, repair, and time compliance technical orders (TCTO) on various munitions components and containers. It consists of multiple drive-through work bays, a tool room, training and ready room, office space, and restrooms. The vehicle traffic pattern within the MSA should provide easy access to and from this building.

4.2.6.1 Facility-Specific Construction Requirements

Interior dividing walls should be a minimum of 12 in (304.8 mm) thick reinforced concrete. Dividing walls between operating bays should have a compressive strength of 2,500 psig (17,170 kPa). Propagation protection for other maintenance operations should be provided between operating bays as outlined for concurrent operations in [AFMAN 91-201](#) and [TM 5-1300/AFM 88-22](#).

Check with the base WSM in the early phase of facility planning for concurrent operations interpretations by the MAJCOMs.

4.2.6.2 Facility-Specific Spatial Requirements

1. The number of bays and bay dimensions are dependent on mission requirements. Usually a minimum of three, 30 ft x 50 ft (9.1 m by 15.2 m) drive-through work bays are required.
2. Space requirements for the adjoining office space must be in accordance with [AFH 32-1084](#).
3. At the minimum, a tool room, training room, ready room, and restrooms should be included.

4.2.6.3 Facility-Specific Mechanical Requirements

HVAC requirements for office and bay areas must comply with requirements defined in Chapter 3, "General Design Guidance."

4.2.6.4 Facility-Specific Electrical Requirements

1. Provide 115 VAC, 60 Hz, single phase and 220 VAC, 60 Hz, 3 phase source as described in [TM 5-811](#) and [AFMAN 91-201](#).
2. Provide grounding, surge protection, and LPS.

4.2.6.5 Other Specific Requirements

1. Provide high security hasps on all bay doors with IDS per [AFI 31-101](#).



2. Bay doors must be a minimum of 10 ft (3 m) high and 16 ft (4.9 m) wide. Actual bay door sizes are dependent on the mission.
3. Provide a 4,000 lb (1,810 kg) transverse-mounted hoist in one bay.
4. Provide pressured air from 0 to 150 psig (0 to 1,030 kPa) in all work bays.

ARCHIVED



Location: Luke AFB, Arizona
Command: AFRC (tenant)
Facility Number: 1240
Date Constructed: 1987

Facility Overview

This facility accommodates weapon assembly and disassembly, corrosion control, maintenance, and repair of practice bombs, 20mm ammunition, flare dispensers, countermeasures, and containers.

Design

- Four work bays and attached administrative space
- Work bay space totals 6,000 sq ft (390.19m²)
- Drive-through access
- Large roll-up doors for vehicle/trailer entry/exit

Space Usage

Size (Total) 7,000 sq ft (650.32m²)
 Category Code 212-213 1,800 sq ft (162m²)
 Category Code 215-582 1,300 sq ft (117m²)
 Category Code 216-642 2,900 sq ft (261m²)



Conventional Munitions Shop



Colocated Administrative Space

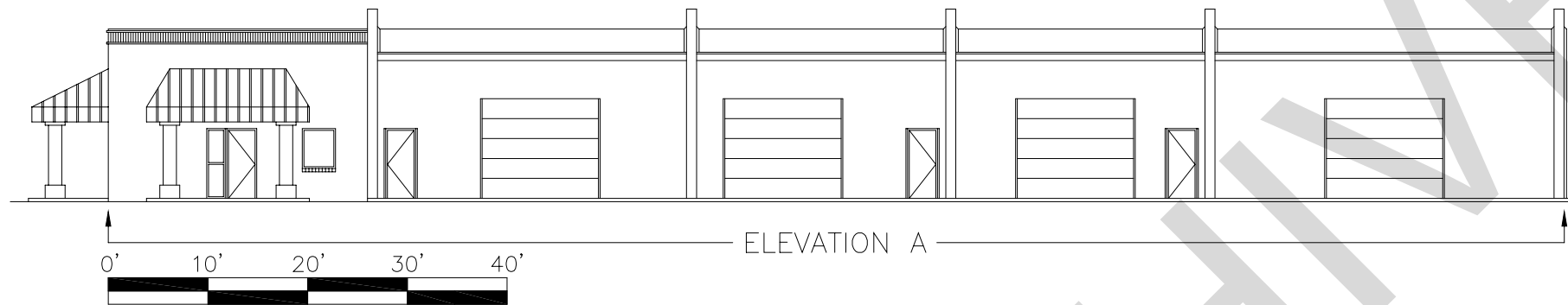

Facility Elevation

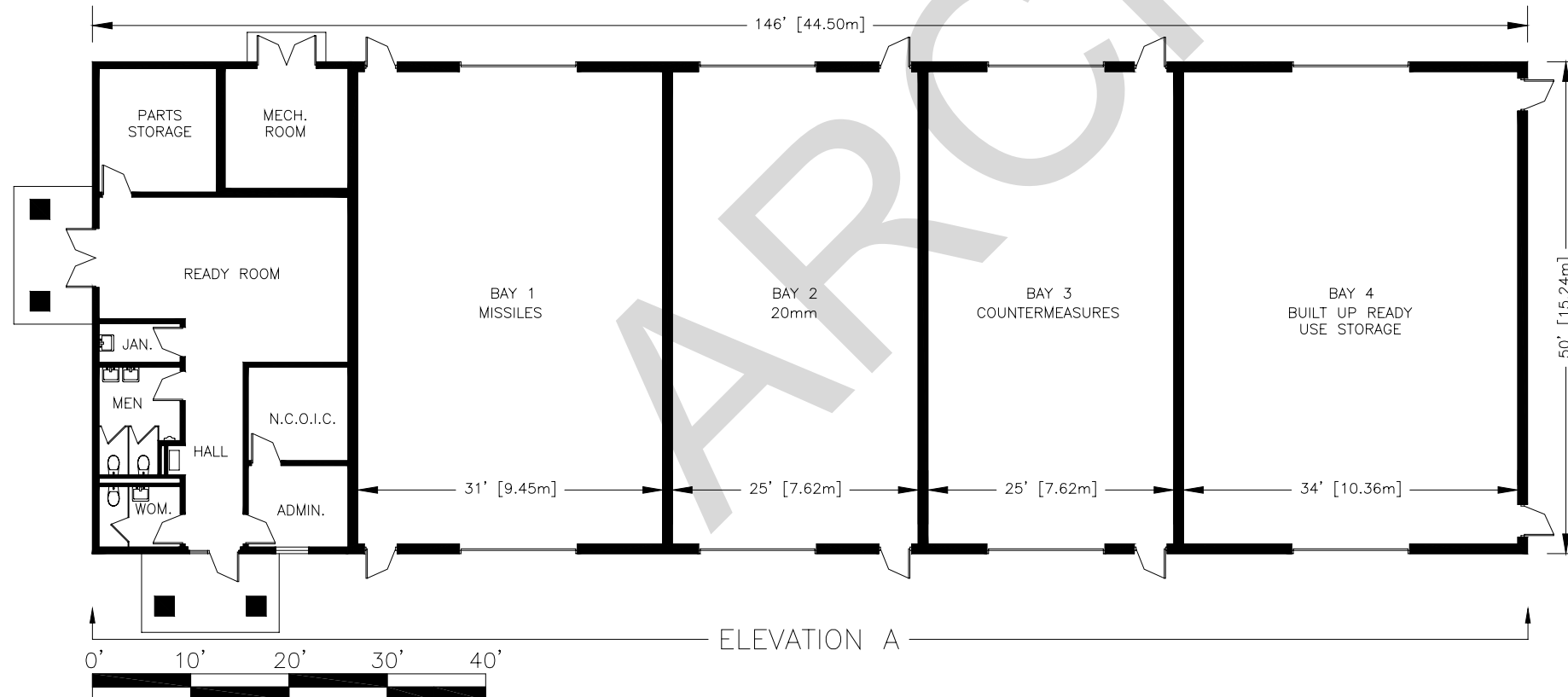

Facility Floor Plan

Category Code 216-642

Conventional Munitions Shop

- Design Related to Aircraft Type**
 Aircraft Type: Fighter
 Primary Aircraft: F-16
- Stand Alone Facility**
- Consolidated Facility**
Other Uses: Missile Maintenance (212-213),
 Surveillance and Inspection (215-582)
- Single Wing**
- Multiple Wings**

Structural	<ul style="list-style-type: none"> • Provide multiple 30 ft (9.1m) long x 50 ft (15.2m) wide work bays • Provide drive-through bays with a minimum roll-up door size of minimum 16 ft (4.9m) wide x 10 ft (3m) high • Provide 12 in (304.8mm) thick reinforced interior concrete dividing walls 2,500 psig (17,170 kPa) • Design exterior apron/pavement and composition to accommodate munitions and MMHE • Provide latrine facilities for assigned personnel • Support area size based upon assigned munitions • Provide a 1,500 sq ft (137m²) administration area
Electrical	<ul style="list-style-type: none"> • Provide 115 VAC, 60 Hz, single phase and 120 VAC, 60 Hz, 3-phase power • Provide UL-approved lighting in areas where explosives vapor or dust hazard are not present • Provide explosive-proof lights per AFMAN 91-201 • Provide emergency power generator(s) • Electrical service to the building per AFMAN 91-201 and NFPA 780
Fire/Safety	<ul style="list-style-type: none"> • Provide lightning and surge protection per NFPA 780, MIL HDBK 419, and AFMAN 91-201 • Provide grounding system per AFI 32-1065 • Provide blast-resistant windows as needed • Provide ventilation/exhaust systems per AFI 32-7040 • Use non-combustible material per UFC 3-600-01 • Provide outward-opening emergency exit doors
Force Protection	<ul style="list-style-type: none"> • Install exterior security lighting based on local threat • Provide high security hasps and intrusion detection system per AFI 31-101
Equipment	<ul style="list-style-type: none"> • Provide overhead transverse-mounted crane/hoist with 4,000-lb (1,810 kg) capacity • Provide paint booth (if required) • Provide low pressure compressed air 0 to 150 psig (0 to 1,030 kPa) and high pressure compressed air 0 to 3,500 psig (0 to 24,100 kPa)

Other References:

- AFH 32-1084 – *Facilities Requirements*
- AFMAN 91-201 – *Explosives Safety Standards*
- AFI 31-101 – *The Physical Security Program*
- DoD 6055.9 STD – *DoD Ammunition and Explosives Safety Standards*

ARCHIVED

Please see the next page.

Location: McChord AFB, Washington
Command: AMC
Facility Number: 368
Date Constructed: 1985

- Design**
- Two large bays with roll-up doors
 - Overhead hoist system in both bays
 - Colocated administrative area
 - Flow-through access

Space Usage
 Size (Total) 3,952 sq ft (367.15m²)

Facility Overview

This facility accommodates weapon assembly and disassembly, corrosion control, maintenance, and repair of practice bombs, 30mm ammunition, flare dispensers, countermeasures, and containers. This facility design is well suited for smaller munitions units.



Conventional Munitions Shop



Maintenance Bay

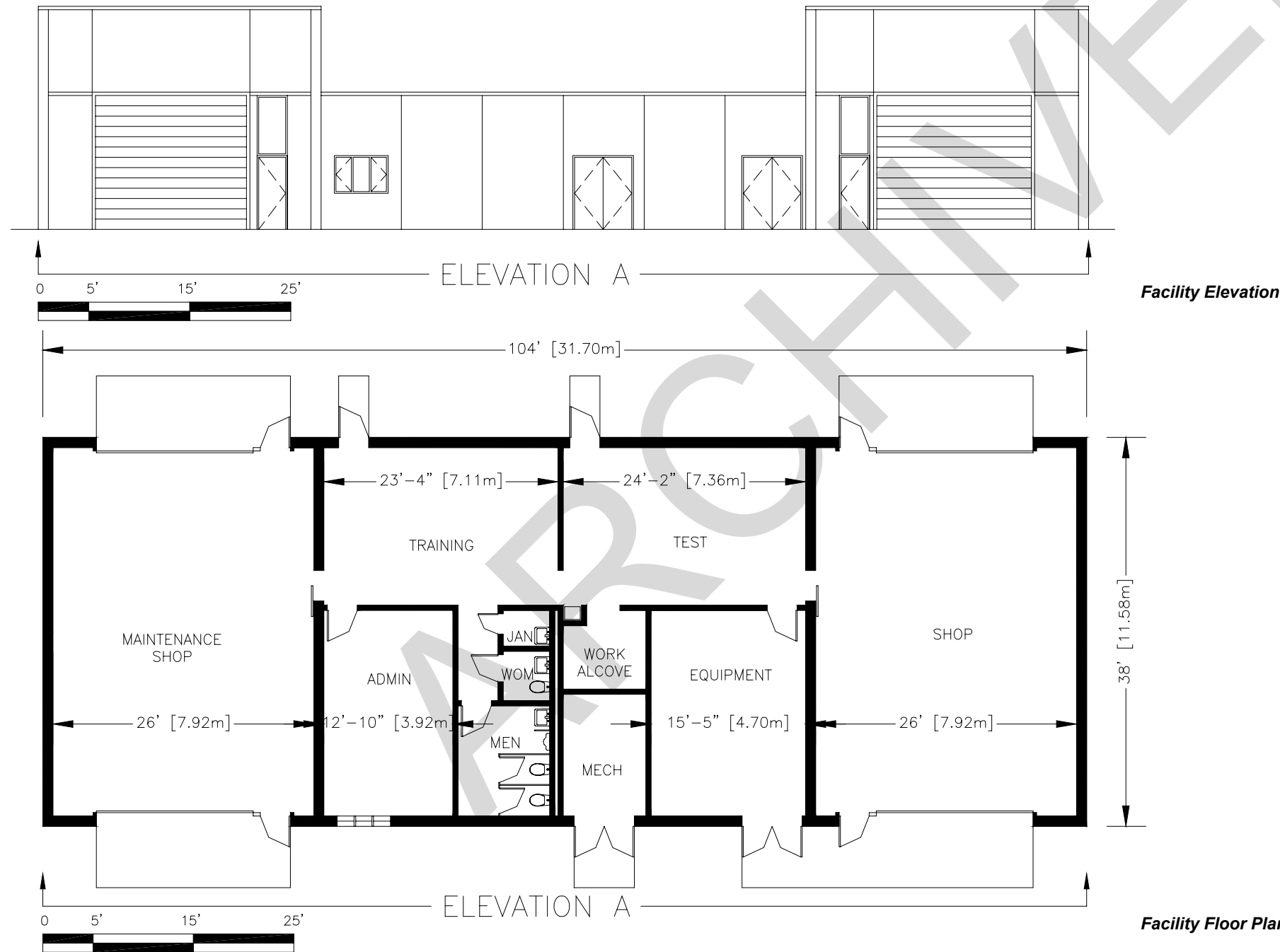

Category Code 216-642

Conventional Munitions Shop

- Design Related to Aircraft Type**
 Aircraft Type: Cargo
 Primary Aircraft: C-17

- Stand Alone Facility**
 Consolidated Facility
Other Uses:

- Single Wing**
 Multiple Wings

Structural	<ul style="list-style-type: none"> • Provide multiple 30 ft (9.1m) wide x 50 ft (15.2m) long work bays • Provide drive-through bays with a minimum roll-up door size of 16 ft (4.9m) wide x 10 ft (3m) high • Provide 12 in (304.8mm) thick reinforced interior concrete dividing walls 2,500 psig (17,170 kPa) • Design exterior apron/pavement and composition to accommodate munitions and MMHE • Provide latrine facilities for assigned personnel • Support area size based upon assigned munitions • Provide a 1,500 sq ft (137m²) administration area
Electrical	<ul style="list-style-type: none"> • Provide 115 VAC, 60 Hz, single phase and 120 VAC, 60 Hz, 3-phase power • Provide UL-approved lighting in areas where explosives vapor or dust hazard are not present • Provide explosive-proof lights per AFMAN 91-201 • Provide emergency power generator(s) • Electrical service to the building per AFMAN 91-201 and NFPA 780
Fire/Safety	<ul style="list-style-type: none"> • Provide lightning and surge protection per NFPA 780, MIL HDBK 419, and AFMAN 91-201 • Provide grounding system per AFI 32-1065 • Provide blast-resistant windows as needed • Provide ventilation/exhaust systems per AFI 32-7040 • Use non-combustible material per UFC 3-600-01 • Provide outward-opening emergency exit doors
Force Protection	<ul style="list-style-type: none"> • Install exterior security lighting based on local threat • Provide high security hasps and intrusion detection system per AFI 31-101
Equipment	<ul style="list-style-type: none"> • Provide overhead transverse-mounted crane/hoist with 4,000-lb (1,810 kg) capacity • Provide paint booth (if required) • Provide low pressure compressed air 0 to 150 psig (0 to 1,030 kPa)

Other References:

- AFH 32-1084 – *Facilities Requirements*
- AFMAN 91-201 – *Explosives Safety Standards*
- AFI 31-101 – *The Physical Security Program*
- DoD 6055.9 STD – *DoD Ammunition and Explosives Safety Standards*

ARCHIVED

Please see the next page.

Category Code 216-642

Conventional Munitions Shop

Location: Pope AFB, North Carolina
Command: ACC (tenant)
Facility Number: 5013
Date Constructed: 2000

- Design**
- Large unobstructed bays
 - Multiple power and compressed air outlets
 - Large roll-up bay doors for flow-through access
 - Colocated administrative space

Space Usage
 Size (Total) 7,873 sq ft (731.61m²)



Facility Provides Good Security Lighting and Personnel Doors Adjacent to Roll-up Doors



Colocated Administrative Space

Facility Overview

This facility accommodates assembly and disassembly, corrosion control, maintenance, and repair of practice bombs, 30mm ammunition, flare dispensers, countermeasures, and containers.



Facility Elevation (NTS)

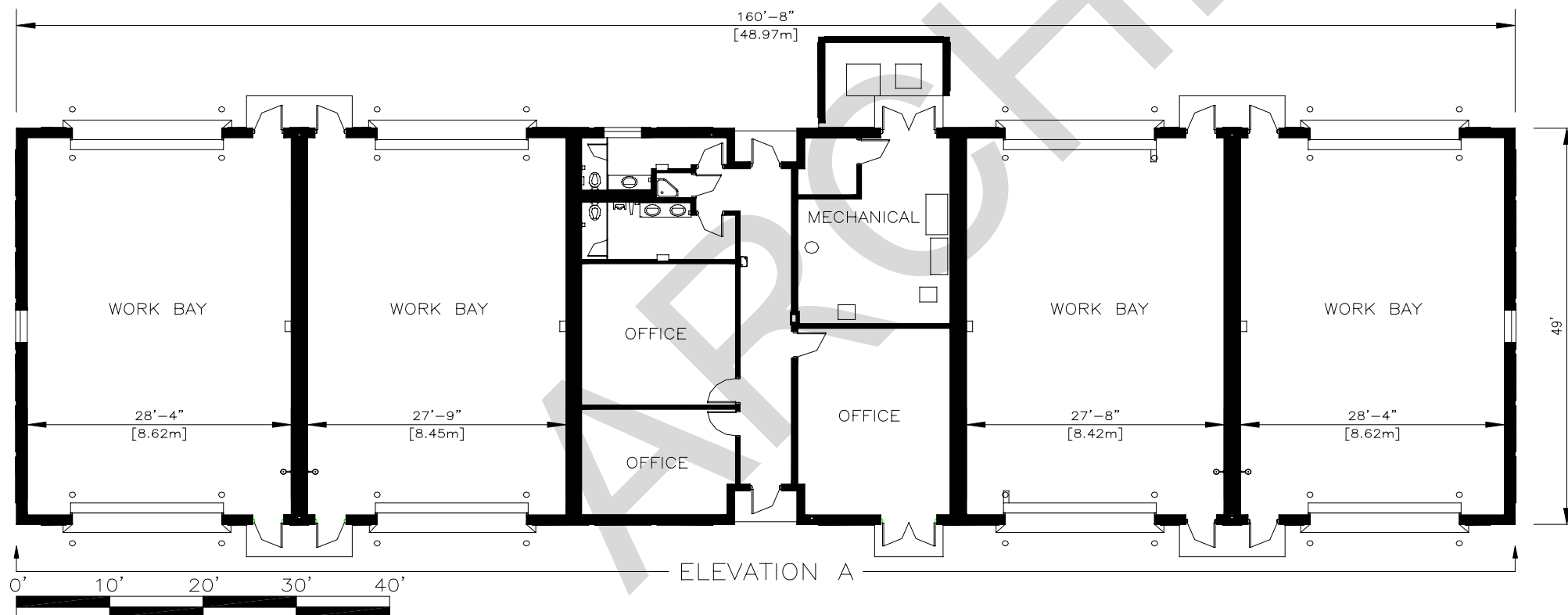

Facility Floor Plan

Design Related to Aircraft Type

Aircraft Type: Fighter
 Primary Aircraft: A-10

Stand Alone Facility

Consolidated Facility

Other Uses:

Single Wing

Multiple Wings

Structural	<ul style="list-style-type: none"> • Provide multiple 30 ft (9.1m) long x 50 ft (15.2m) wide work bays • Provide drive-through bays with a minimum roll-up door size of 16 ft (4.9m) wide x 10 ft (3m) high • Provide 12 in (304.8mm) thick reinforced interior concrete dividing walls 2,500 psig (17,170 kPa) • Design exterior apron/pavement and composition to accommodate munitions and MMHE • Provide latrine facilities for assigned personnel • Support area size based upon assigned equipment • Provide a 1,500 sq ft (137m²) administration area
Electrical	<ul style="list-style-type: none"> • Provide 115 VAC, 60 Hz, single phase and 220 VAC, 60 Hz, 3-phase power (if required) • Provide UL-approved lighting in areas where explosives vapor or dust hazard are not present • Provide explosive-proof lights per AFMAN 91-201 • Provide emergency power generator(s) • Electrical service to the building per AFMAN 91-201 and NFPA 780
Fire/Safety	<ul style="list-style-type: none"> • Provide lightning and surge protection per NFPA 780, MIL HDBK 419, and AFMAN 91-201 • Provide grounding system per AFI 32-1065 • Provide blast-resistant windows as needed • Provide ventilation/exhaust systems per AFI 32-7040 • Use non-combustible material per UFC 3-600-01 • Provide outward-opening emergency exit doors
Force Protection	<ul style="list-style-type: none"> • Install exterior security lighting based on local threat • Provide high security hasps and intrusion detection system per AFI 31-101
Equipment	<ul style="list-style-type: none"> • Provide overhead transverse-mounted crane/hoist with 4,000-lb (1,810 kg) capacity • Provide paint booth (if required) • Provide low pressure compressed air 0 to 150 psig (0 to 1,030 kPa)

Other References:

- AFH 32-1084 – Facilities Requirements
- AFMAN 91-201 – Explosives Safety Standards
- AFI 31-101 – The Physical Security Program
- DoD 6055.9 STD – DoD Ammunition and Explosives Safety Standards

ARCHIVED

Please see the next page.

Location: Whiteman AFB, Missouri
Command: ACC
Facility Number: 4077
Date Constructed: 2002

Facility Overview

This facility accommodates weapon assembly and disassembly, corrosion control, maintenance, repair of practice and general purpose bombs, and containers.

Design

- Located close to flight line to facilitate buildup operations
- One large bay with six roll-up doors
- Five-ton overhead hoist system
- Colocated administrative and break space
- Storage space on second floor
- Protected by catenary lightning protection system
- Security fencing and overhead lighting

Space Usage

Size (Total) 11,227 sq ft (1,043.02m²)



Drive-through Doors and Large Pad for Improved Access



Mezzanine Provides Storage above the Administration Area

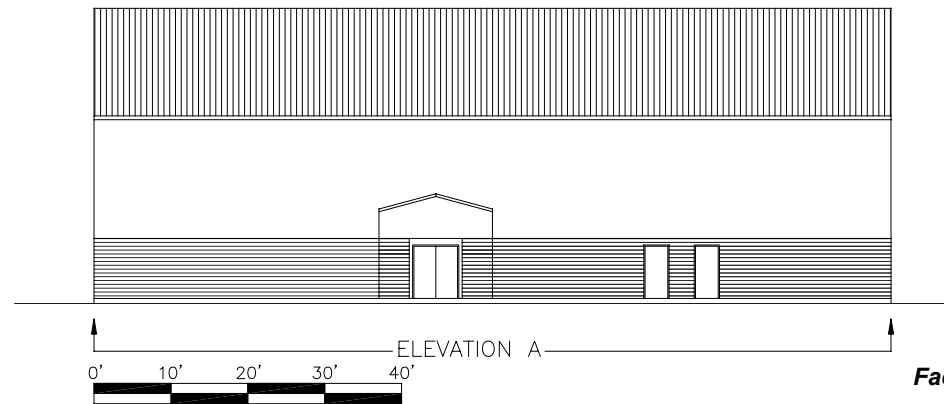

Facility Elevation

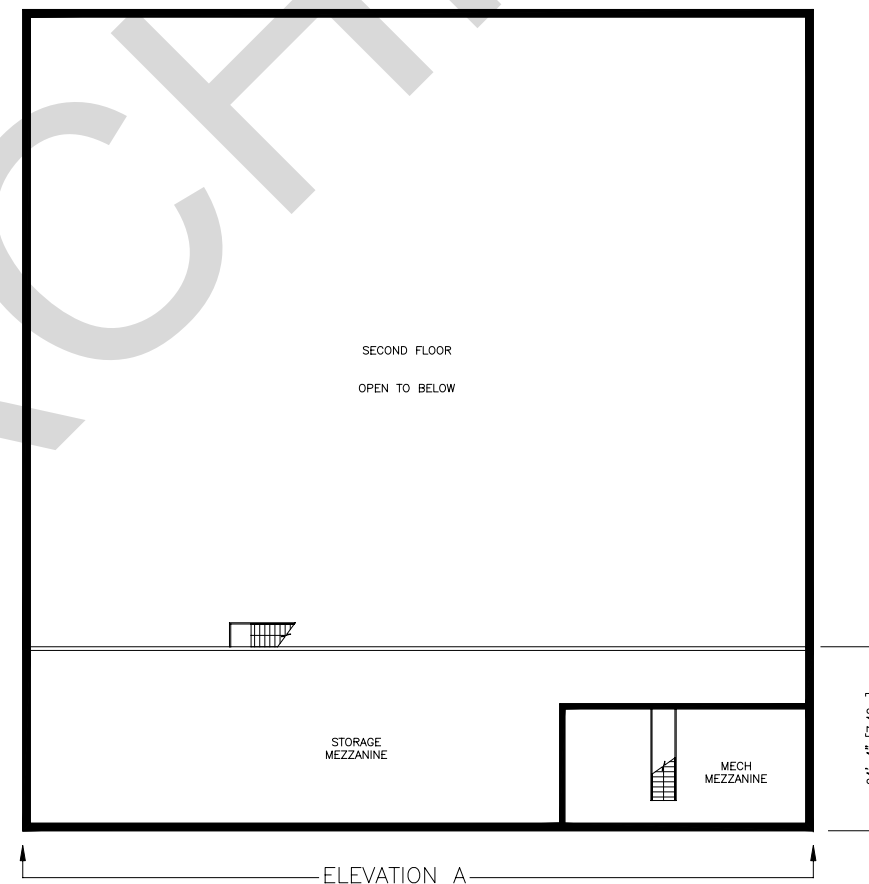
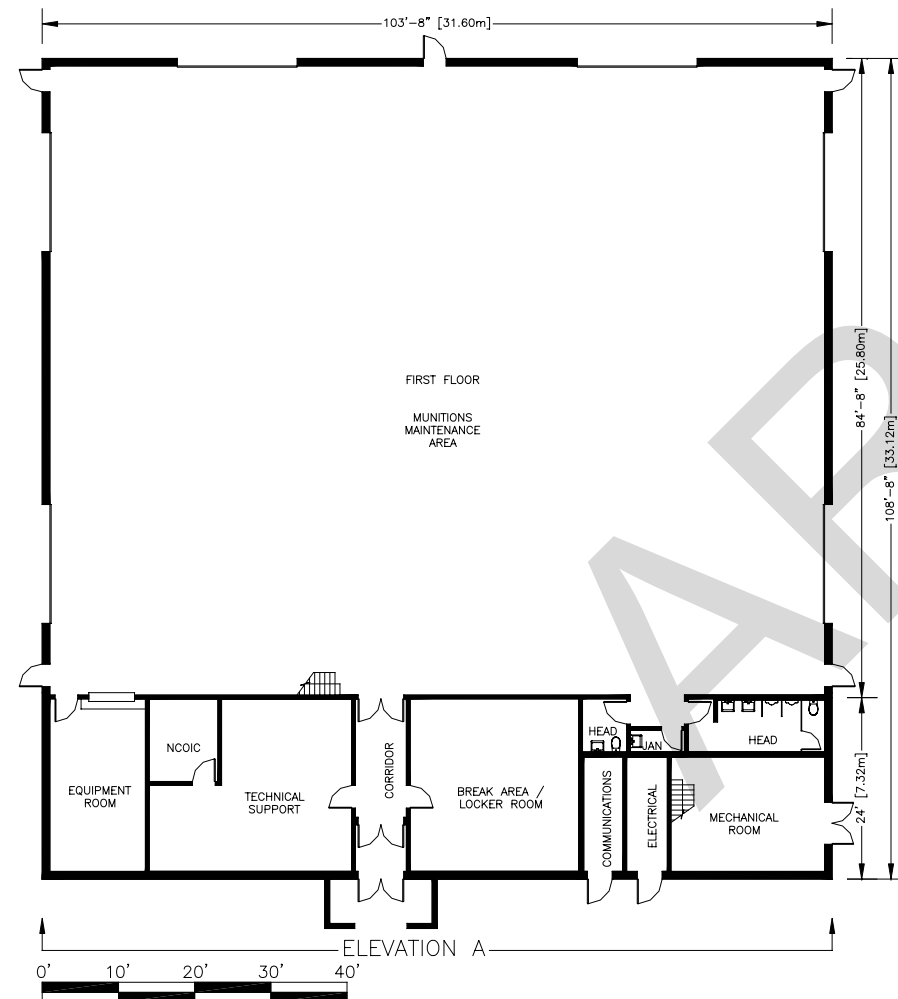

Facility Floor Plan

Category Code 216-642

Conventional Munitions Shop

Design Related to Aircraft Type

Aircraft Type: Bomber
 Primary Aircraft: B-2

Stand Alone Facility

Consolidated Facility

Other Uses:

Single Wing

Multiple Wings

Structural	<ul style="list-style-type: none"> • Provide multiple 30 ft (9.1m) long x 50 ft (15.2m) wide work bays • Provide drive-through bays with a minimum roll-up door size of 16 ft (4.9m) wide x 10 ft (3m) high • Provide 12 in (304.8mm) thick reinforced interior concrete dividing walls 2,500 psig (17,170 kPa) • Design exterior apron/pavement and composition to accommodate munitions and MMHE • Provide latrine facilities for assigned personnel • Support area size based upon assigned equipment • Provide a 1,500 sq ft (137m²) administration area
Electrical	<ul style="list-style-type: none"> • Provide 115 VAC, 60 Hz, single phase and 120 VAC, 60 Hz, 3-phase power • Provide UL-approved lighting in areas where explosives vapor or dust hazard are not present • Provide explosive-proof lights per AFMAN 91-201 • Provide emergency power generator(s) • Electrical service to the building per AFMAN 91-201 and NFPA 780
Fire/Safety	<ul style="list-style-type: none"> • Provide lightning and surge protection per NFPA 780, MIL HDBK 419, and AFMAN 91-201 • Provide grounding system per AFI 32-1065 • Provide blast-resistant windows as needed • Provide ventilation/exhaust systems per AFI 32-7040 • Use non-combustible material per UFC 3-600-01 • Provide outward-opening emergency exit doors
Force Protection	<ul style="list-style-type: none"> • Install exterior security lighting based on local threat • Provide high security hasps and intrusion detection system per AFI 31-101
Equipment	<ul style="list-style-type: none"> • Provide overhead transverse-mounted crane/hoist with 4,000-lb (1,810 kg) capacity • Provide paint booth (if required) • Provide low pressure compressed air 0 to 150 psig (0 to 1,030 kPa)

Other References:

- AFH 32-1084 – *Facilities Requirements*
- AFMAN 91-201 – *Explosives Safety Standards*
- AFI 31-101 – *The Physical Security Program*
- DoD 6055.9 STD – *DoD Ammunition and Explosives Safety Standards*

ARCHIVED

Please see the next page.



Figure 4.14
Powered Trailer Facility -
Barksdale AFB, LA

4.2.7

Category Code 218-712

Aircraft Support Equipment Shop/Storage Facility (Aerospace Ground Equipment (AGE) Facility) - Used for Munitions Support Equipment Maintenance

This facility is used for inspecting, maintaining, servicing, and repairing assigned powered and non-powered munitions materiel handling equipment (MMHE). Requirements for the number of munitions trailers maintained in the facility will vary depending upon the unit's mission. General guidance for aircraft support equipment shop/storage facility (AGE Facility) is found in [AFH 32-1084](#). Restrooms and a break area are authorized for this facility.

4.2.7.1 Facility-Specific Construction Requirements

Office areas require sound attenuation.

4.2.7.2 Facility-Specific Spatial Requirements

1. Includes maintenance stalls with workbenches, a wash rack, tool crib, bench stock, office space, and personnel locker space.
2. An enclosed storage facility is authorized if powered munitions trailers are assigned to the installation. This facility should be near the support equipment maintenance shop to house equipment not in use. Space required is stated in [AFH 32-1084](#).
3. Allow 230 sq yds (192 m²) of space per authorized powered munitions trailer assigned to each facility.

4.2.7.3 Facility-Specific Mechanical Requirements

1. A segregated and enclosed paint booth or facility is required to meet environmental requirements associated with sanding, brake work, corrosion control, and surface painting.
2. The paint booth area in this facility requires special ventilation and/or exhaust evacuation. Consult with base Bio-Environmental office for further guidance. All AGE facilities must comply with local, state and federal requirements for air emissions, as required in [AFI 32-7040](#).
3. HVAC requirements for office areas must comply with requirements defined in Chapter 3, "General Design Guidance."



4.2.7.4 Facility-Specific Electrical Requirements

1. Provide 120 VAC, 60 Hz and 220 VAC, 60 Hz power as described in [TM 5-811](#) and [AFMAN 91-201](#).
2. Additionally, 440 VAC power is required for powered trailers. The 440 VAC receptacles are required in sufficient quantities and copiously spaced to allow for the operation of powered trailers in and around the facility.

4.2.7.5 Other Specific Requirements

1. A 10-ton (9,070 kg) overhead hoist for trailer support equipment is required for powered trailers and a 5-ton (4,540 kg) hoist is required for non-powered trailers.
2. A wash rack with hot and cold water is required.
3. An oil-water separator is required for the wash rack. Refer to [MIL HDBK 1190](#), *Facility Planning and Design Guide*, for oil-water separators servicing wash racks.
4. Air pressure from 0 to 120 psig (0 to 827 kPa) is required in all work bays.



Location: Misawa AB, Japan
Command: PACAF
Facility Number: 1497
Date Constructed: 1985

Facility Overview

This facility is used to inspect, maintain, repair, and service assigned powered and non-powered munitions materiel handling equipment.

Design

- Large unobstructed work bays
- High ceilings and hoist systems allow for stacking of materials
- Large surrounding apron
- Colocated administrative office space
- Mezzanine space provides a break area and conference space

Space Usage

Size (Total) 6,283 sq ft (583.71m²)



Equipment Maintenance Shop and Storage Facility (Rear View)



Large Unobstructed Work Bays

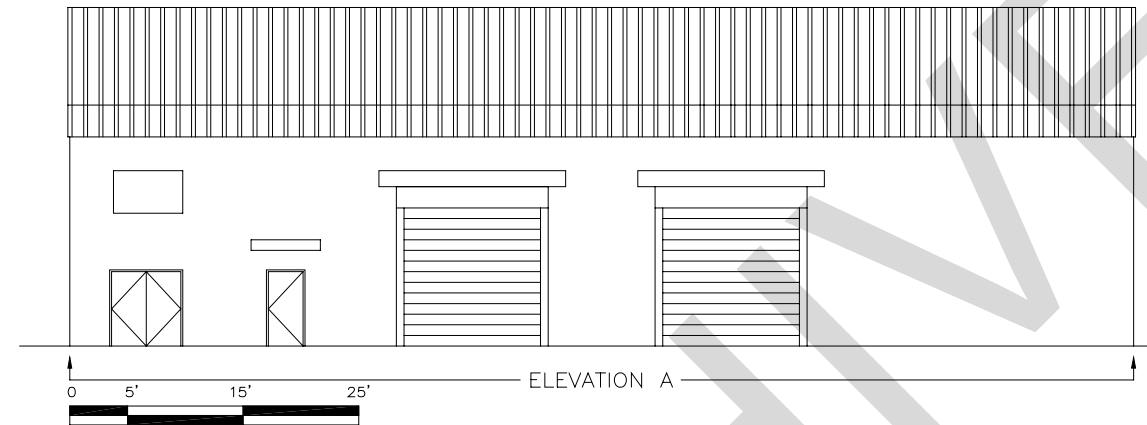

Facility Elevation



Facility Floor Plan

Category Code 218-712

**Aircraft Ground Equipment Shop/
AGE Facility**

Design Related to Aircraft Type

Aircraft Type: Fighter
 Primary Aircraft: F-16

Stand Alone Facility

Consolidated Facility

Other Uses:

Single Wing

Multiple Wings

Structural

- Provide 2,070 sq ft (192 m²) of work space per authorized powered munitions trailer
- Provide drive-through bays with a minimum rollup door size of 10 ft (3.04 m) wide x 10 ft (3.04 m) high
- Design exterior apron/pavement and composition to accommodate MMHE
- Provide latrine facilities for assigned personnel
- Provide a 1,500 sq ft (137 m²) administration area

Electrical

- For non-powered trailers, provide 115 and 220VAC, 60 Hz, single phase power
- For powered trailers, provide 120, 220, and 440VAC, 60 Hz, 3-phase power
- Minimum 5 foot-candles interior lighting

Fire/Safety

- Provide lightning and surge protection per NFPA 780 and MIL HDBK 419
- Provide grounding system per AFI 32-1065
- Provide blast-resistant windows as needed
- Provide ventilation/exhaust systems per AFI 32-7040
- Use non-combustible material per UFC 3-600-01
- Provide outward-opening emergency exit doors

Force Protection

- Install exterior security lighting based on local threat assessment

Equipment

- Provide 10-ton (9,070 kg) overhead hoist for powered MMHE units and 5-ton (4,540 kg) overhead hoist for non-powered MMHE units
- Provide wash rack with hot/cold water, floor drainage for oil-water separator per MIL HDBK 1190
- Provide paint booth if required
- Provide low pressure compressed air 0 to 120 psig (0 to 827 kPa)

Other References:

- AFH 32-1084 – Facilities Requirements
- AFMAN 91-201 – Explosives Safety Standards
- AFI 31-101 – The Physical Security Program
- DoD 6055.9 STD – DoD Ammunition and Explosives Safety Standards

ARCHIVED

Please see the next page.

Basic Design Standards for Munitions Storage Facilities

- [AFH 32-1084](#),
Facility Requirements
- [AFI 32-1021](#),
*Planning and
Programming
Military Construction
(MILCON) Projects*
- [AFMAN 91-201](#),
*Explosives Safety
Standards*
- [TM 5-1300/AFR 88-
22](#), *Structures to
Resist the Effects of
Accidental Explosions*
- [DoD 5100.76-M](#),
*Physical Security of
Sensitive
Conventional Arms,
Ammunition and
Explosives*
- [Mil HDBK 1013/1A](#),
*Design Guidelines for
Physical Security of
Facilities*
- [DoD 6055.9-STD](#),
*DoD Ammunition and
Explosives Safety
Standard*
- [Technical Order](#)
(T.O.) 11A-1-61-4,
and pertinent
technical orders of the
11A, 11C, 11G, 11K,
11N, and 11P series

4.3 Munitions Storage Facilities

Munitions storage facilities are used to store munitions explosives materiel, inert components, and equipment used for the operating requirements of the Air Force. [AFH 32-1084](#) contains definitions for category codes pertaining to storage facilities.

Munitions storage factors include Q-D, location of existing storage facilities, Net Explosives Weight (NEW), hazard class/division, compatibility groups, physical size of items to be stored, unique security safeguards, and regulatory requirements as to type of facility and storage configuration.

The following are common criteria for munitions storage facilities.

1. The MSA is an area reserved exclusively for explosives storage, as defined in [AFMAN 91-201](#). Inert spares storage facilities may be located outside the explosives clear zone. Also, the rocket check out and assembly storage facility may be licensed for explosives if located outside the MSA. Incoming vehicle inspection and interchange yards may not need explosives siting. AFMAN 91-201 contains details on explosives siting rules.
2. The proper placement of earth barricades around explosives storage facilities enhances the safety of personnel and protection of property. [AFMAN 91-201](#) contains details on earth barricade use and construction.
3. Where two or more commands operate from an installation, storage facilities should be integrated into a single MSA to the maximum extent possible.
4. Depending on use, storage facilities may require electrical outlets and interior/exterior lighting.
5. Explosion-proof fixtures are required if there is a Class I (explosive vapor) or Class II (explosive dust) hazard present.
6. Munitions, materiel, and support equipment used for the operating requirements of the Air Force are kept in storage facilities under the responsibility of the using organization.
7. References relating to munitions storage facility planning are listed in the text box in the margin.
8. High security hasps are required on all facility doors protected by an intrusion detection system as required by [AFI 31-101](#). Break-in resistance measures (e.g. reinforcement) are required for doors, exterior walls, and roofs.



Please see the next page.

ARCHIVED





Figure 4.15
Multi-cubicle Magazine
Storage -
McChord AFB, WA



Figure 4.16
Multi-cubicle Magazine
Storage -
Langley AFB, VA

4.3.1 Category Code 422-253 Multi-cubicle Magazine Storage

Multi-cubicle magazines are a category of above ground munitions storage magazines used to store small quantities of explosives. Because of their small size and separation of adjoining bays, they are ideal for segregating incompatible hazard classifications and explosives groups and for supporting munitions custody account customers. This facility may also be used to store combat alert loaded munitions trailers and can be accessed with most munitions support equipment.

4.3.1.1 Facility-Specific Construction Requirements

Interior dividing walls should be a minimum of 12 in (304.8 mm) thick reinforced concrete. Dividing walls between storage bays should have a compressive strength of 2,500 psig (17,170 kPa). Propagation protection for other storage bays should be provided between bays as outlined in [AFMAN 91-201](#) and [TM 5-1300/AFM 88-22](#).

4.3.1.2 Facility-Specific Spatial Requirements

Facility size and number of bays dependent upon mission requirements.

4.3.1.3 Facility-Specific Mechanical Requirements

May require HVAC for climate control depending on assets to be stored and local climate conditions.

4.3.1.4 Facility-Specific Electrical Requirements

1. Provide grounding, surge protection, and LPS.
2. May require electrical outlets and interior/exterior lighting as described in [TM 5-811](#) and [AFMAN 91-201](#).

4.3.1.5 Other Specific Requirements

1. Doors must have high security hasps and may need an intrusion detection system per [AFI 31-101](#).
2. Facility doors will be made of steel and may be hinged, sliding, or roll-up type.
3. Apron in front of doors must be large enough to permit safe operation of munitions support equipment.



Please see the next page.

ARCHIVED



Location: Barksdale AFB, Louisiana
Command: AFRC
Facility Number: 7570
Date Constructed: 2000

Facility Overview

This facility is used to store small quantities of explosives. Facilities are often used to segregate compatible groups of munitions and for storing explosive assets belonging to custody accounts.

Design

- Wide roll-up bay doors
- Header above door provides excellent system for posting hazard and safety signage
- Exterior and interior lighting
- Large surrounding apron to support GOV and MMHE usage

Space Usage

Size (Total) 1,960 sq ft (182.09m)



Segregated Bay Storage Area



Cast-in-place Concrete Construction

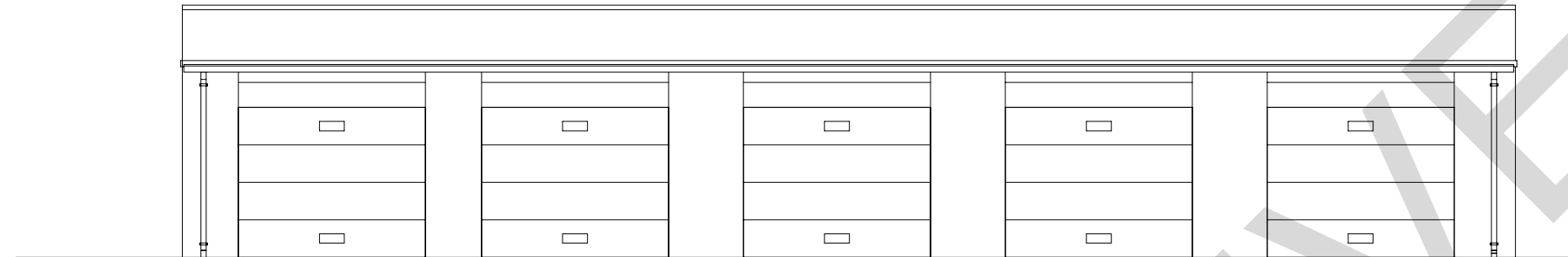

ELEVATION A

[21.34m]

Facility Elevation

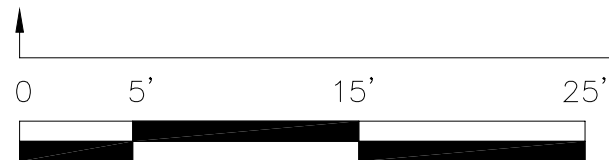
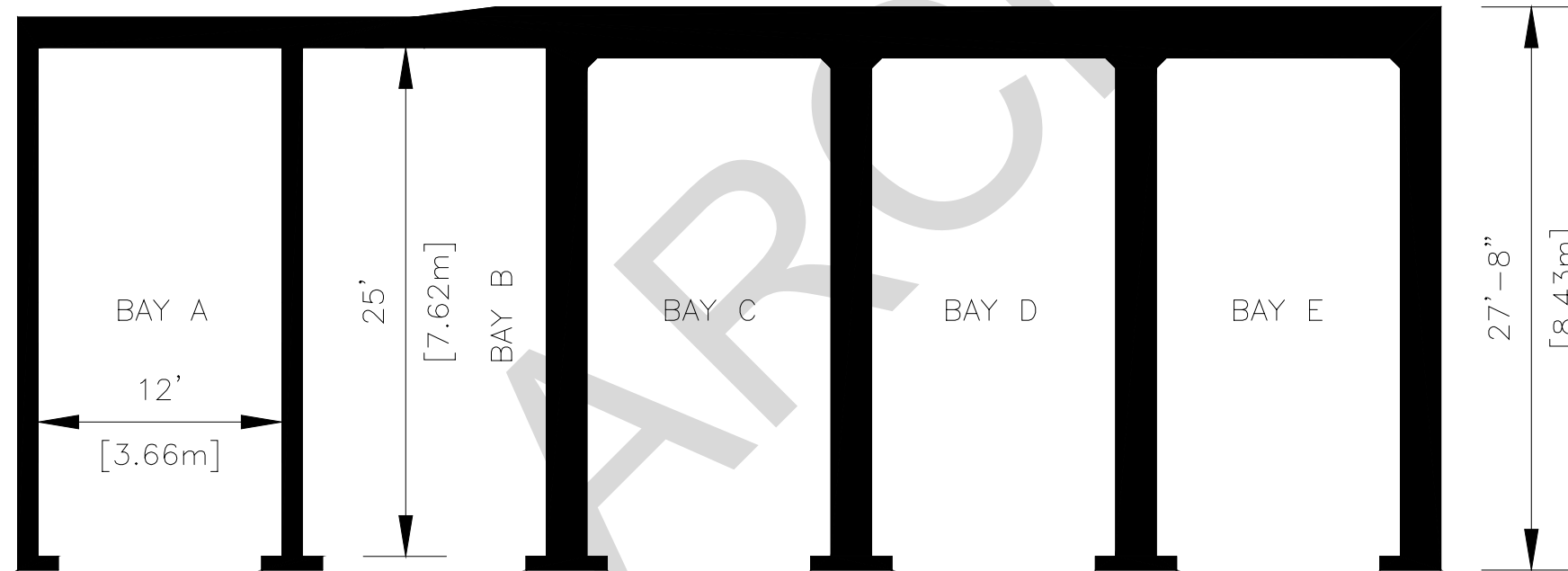

ELEVATION A

Facility Floor Plan

Category Code 422-253

Multi-cubicle Magazine Storage

Design Related to Aircraft Type

Aircraft Type: B-52
 Primary Aircraft: Bomber

Stand Alone Facility

Consolidated Facility

Other Uses:

Single Wing

Multiple Wings

Structural	<ul style="list-style-type: none"> • Facility size and number of bays dependent upon mission requirements • Provide 12 in (304.8mm) thick reinforced interior/exterior concrete dividing walls 2,500 psig (17,170 kPa) • Design exterior apron/pavement and composition to accommodate MMHE • Facility doors shall be made of steel and may be hinged, sliding, or roll-up type
Electrical	<ul style="list-style-type: none"> • May require electrical outlets and interior/exterior lighting • Provide UL-approved lighting in areas where explosives vapor or dust hazard are not present • Provide explosive-proof lights per AFMAN 91-201 • Electrical service to the building per AFMAN 91-201 and NFPA 780
Fire/Safety	<ul style="list-style-type: none"> • Provide lightning and surge protection per NFPA 780, MIL HDBK 419, and AFMAN 91-201 • If required, provide barricades per AFMAN 91-201 • Barricade wall must meet two degree rule, and must be 3 ft (914.4 mm) wide at top in accordance with AFMAN 91-201
Force Protection	<ul style="list-style-type: none"> • Install exterior security lighting based on local threat • Provide high security hasps and intrusion detection system per AFI 31-101
Equipment	<ul style="list-style-type: none"> • May require climate control dependent on munitions type and local climate

Other References:

- AFH 32-1084 – Facilities Requirements
- AFMAN 91-201 – Explosives Safety Standards
- AFI 31-101 – The Physical Security Program
- DoD 6055.9 STD – DoD Ammunition and Explosives Safety Standards

ARCHIVED

Please see the next page.

Location: Hill AFB, Utah
Command: AFMC
Facility Number: 1378
Date Constructed: 1987

Facility Overview

This facility is used to store small quantities of explosives. Facilities are often used to segregate incompatible groups of munitions for the base and explosives assets belonging to custody accounts.

Design

- Facility is earth covered to improve climate control and explosives safety
- Wide bay doors for easy access
- Excellent space for vehicle flow around facility
- Can be easily modified to accommodate increased mission requirements

Space Usage

Size (Total) 17,784 sq ft (1,652.19m²)



Segregated Bay Storage Area



Wide Hinged Doors

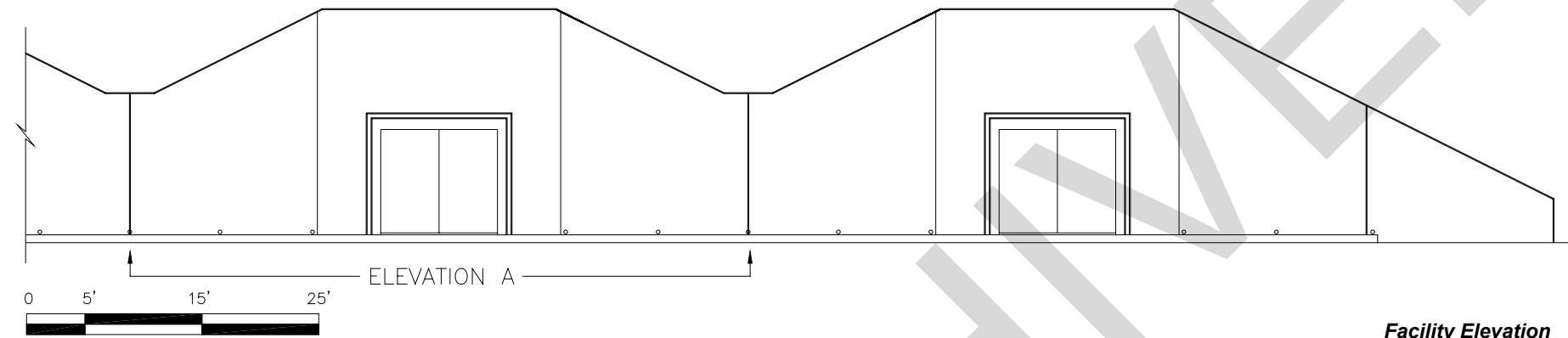

Facility Elevation

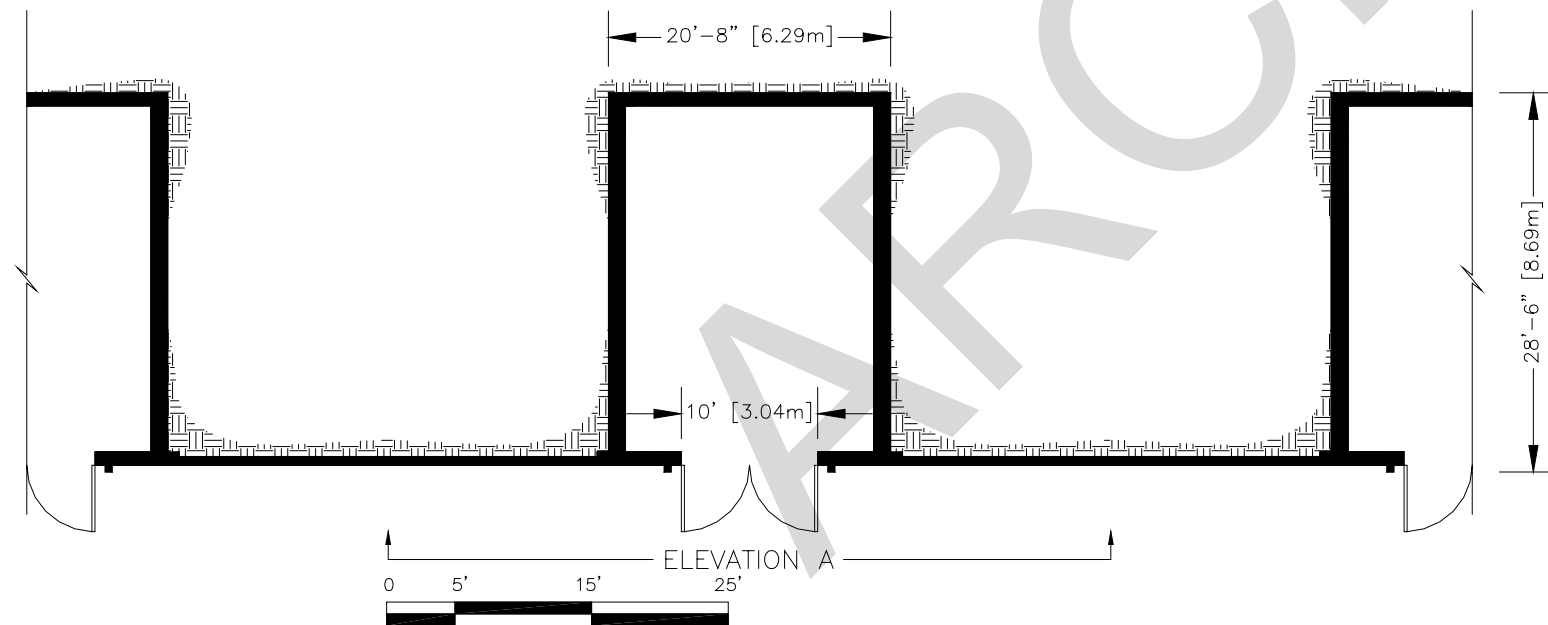

Facility Floor Plan

Category Code 422-253

Multi-cubicle Magazine Storage

Design Related to Aircraft Type

Aircraft Type: Multiple
 Primary Aircraft: Multiple

Stand Alone Facility

Consolidated Facility

Other Uses:

Single Wing

Multiple Wings

Structural	<ul style="list-style-type: none"> • Facility size and number of bays dependent upon mission requirements • Provide 12 in (304.8mm) thick reinforced interior/exterior concrete dividing walls 2,500 psig (17,170 kPa) • Design exterior apron/pavement and composition to accommodate MMHE • Facility doors shall be made of steel and may be hinged, sliding, or roll-up type
Electrical	<ul style="list-style-type: none"> • May require electrical outlets and interior/exterior lighting • Provide UL-approved lighting in areas where explosives vapor or dust hazard are not present • Provide explosive-proof lights per AFMAN 91-201 • Electrical service to the building per AFMAN 91-201 and NFPA 780
Fire/Safety	<ul style="list-style-type: none"> • Provide lightning and surge protection per NFPA 780, MIL HDBK 419, and AFMAN 91-201 • Provide grounding system per AFI 32-1065 • If required, provide barricades per AFMAN 91-201. Wall must meet 2-degree rule, and must be 3 ft (914.4mm) wide at top in accordance with AFMAN 91-201.
Force Protection	<ul style="list-style-type: none"> • Install exterior security lighting based on local threat • Provide high security hasps and intrusion detection system per AFI 31-101
Equipment	<ul style="list-style-type: none"> • May require climate control dependent on munitions type and local climate

Other References:

- AFH 32-1084 – Facilities Requirements
- AFMAN 91-201 – Explosives Safety Standards
- AFI 31-101 – The Physical Security Program
- DoD 6055.9 STD – DoD Ammunition and Explosives Safety Standards

ARCHIVED

Please see the next page.

Location: Shaw AFB, South Carolina
Command: ACC
Facility Number: 1880
Date Constructed: 1989

Facility Overview

This facility is used to store small quantities of explosives. Facilities are often used to segregate incompatible groups of munitions for the base and explosives assets belonging to custody accounts.

Design

- Wide roll-up bay doors
- Dividing walls extend through the roof for additional explosives safety
- Excellent system for posting hazard and safety signage
- Exterior lights can be extended to light bays
- Large surrounding apron to support GOV and MMHE usage
- Each bay has slap bars

Space Usage

Size (Total) 4,148 sq ft (385.36m²)



Multi-cubicle Magazine Storage Facility



Door-Mounted Signage

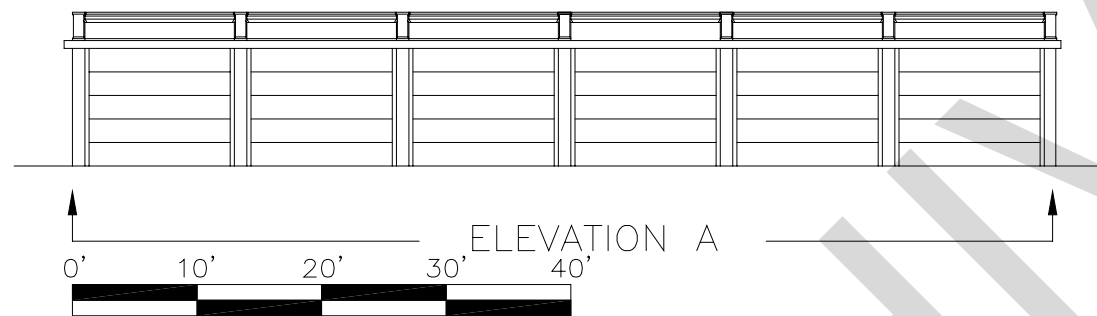

Facility Elevation

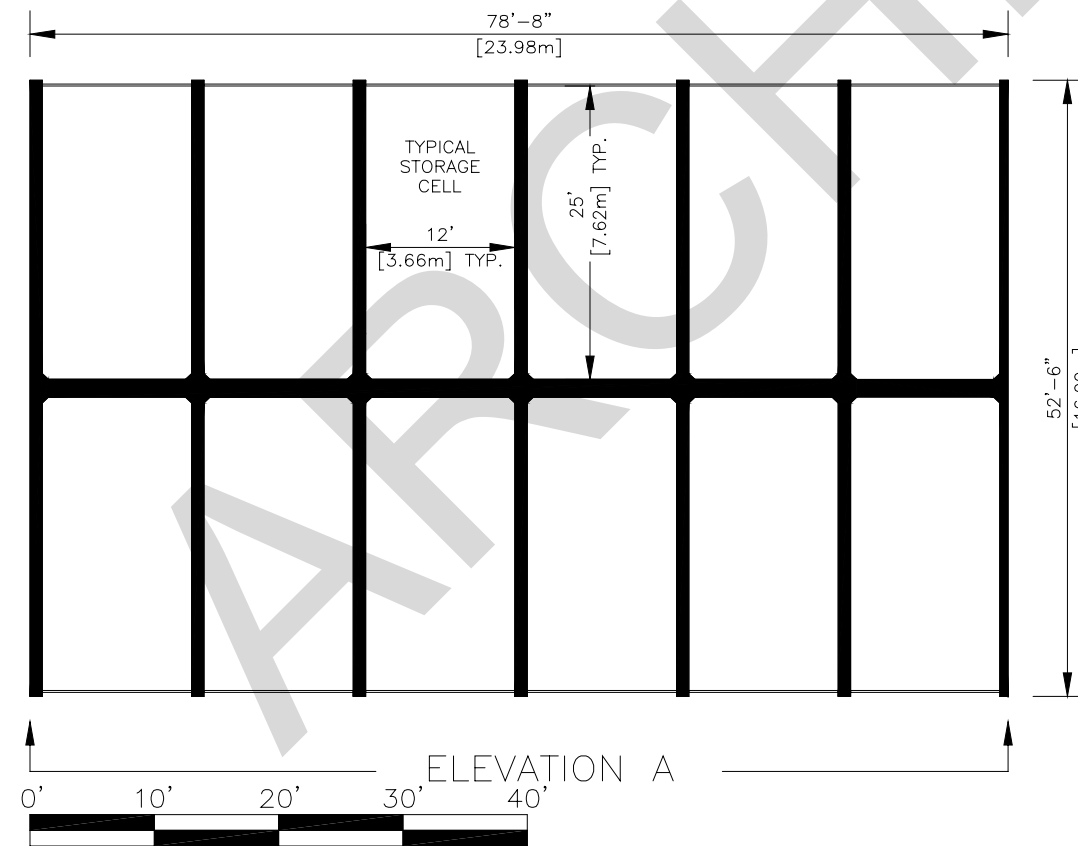

Facility Layout

Category Code 422-253

Multi-cubicle Magazine Storage

- Design Related to Aircraft Type**
 Aircraft Type: Fighter
 Primary Aircraft: F-16

- Stand Alone Facility**
- Consolidated Facility**
- Other Uses:**

- Single Wing**
- Multiple Wings**

Structural	<ul style="list-style-type: none"> • Facility size and number of bays dependent upon mission requirements • Provide 12 in (304.8mm) thick reinforced interior/ exterior concrete dividing walls 2,500 psig (17,170 kPa) • Design exterior apron/pavement and composition to accommodate MMHE • Facility doors shall be made of steel and may be hinged, sliding, or roll-up type
Electrical	<ul style="list-style-type: none"> • May require electrical outlets and interior/exterior lighting • Provide UL-approved lighting in areas where explosives vapor or dust hazard are not present • Provide explosive-proof lights per AFMAN 91-201 • Electrical service to the building per AFMAN 91-201 and NFPA 780
Fire/Safety	<ul style="list-style-type: none"> • Provide lightning and surge protection per NFPA 780, MIL HDBK 419, and AFMAN 91-201 • If required, provide barricades per AFMAN 91-201 • Barricade wall must meet two degree rule, and must be 3 ft (914.4 mm) wide at top in accordance with AFMAN 91-201
Force Protection	<ul style="list-style-type: none"> • Install exterior security lighting based on local threat • Provide high security hasps and intrusion detection system per AFI 31-101
Equipment	<ul style="list-style-type: none"> • May require climate control dependent on munitions type and local climate

Other References:

- AFH 32-1084 – Facilities Requirements
- AFMAN 91-201 – Explosives Safety Standards
- AFI 31-101 – The Physical Security Program
- DoD 6055.9 STD – DoD Ammunition and Explosives Safety Standards

ARCHIVED

Please see the next page.

4.3.2

Category Code 422-256

Rocket Check Out and Assembly Storage

Rocket check out and assembly storage facilities are unique in that they serve as an operating location to accommodate the assembly, disassembly, and electrical check out of rockets as well as providing a site to store built-up rockets. Since the addition of the MK-66 rocket motor in the inventory, electrical continuity checks of rocket motors are rare. This facility is now often used for other munitions operations (e.g., flare and chaff build-up, argon recharging, small bomb assembly, 20mm replenishing, etc.).

Rocket check out and assembly storage facilities located within the MSA shall be included on the explosives site plan. If located outside the MSA, an approved explosives license must be obtained. Restrooms may be appropriate if facility is used as an operating location.

4.3.2.1 Facility-Specific Construction Requirements

1. The facility will be constructed of concrete.
2. The 12 in (304.8 mm) thick reinforced concrete walls should have compression strength of 2,500 psig (17,170 kPa) and be positioned so the rockets face the reinforced walls during build-up operations and storage.

Check with the base WSM in the early phase of facility planning for concurrent operations interpretations by the MAJCOMs.

3. Facility doors will be made of steel and must be a minimum of 3/8 in (9.5 mm) thick.

4.3.2.2 Facility-Specific Spatial Requirements

The complete facility contains 11,160 sq ft (1,040 m²) including area for a field office, but size varies depending on mission requirements.

4.3.2.3 Facility-Specific Mechanical Requirements

May require HVAC for climate control depending on assets to be stored and local climate conditions.

4.3.2.4 Facility-Specific Electrical Requirements

1. May require electrical outlets and interior/exterior lighting.
2. Provide grounding, surge protection, and LPS.
3. Must have 120 VAC, 60 Hz, single-phase electricity as described in [TM 5-811](#) and [AFMAN 91-201](#).



4.3.2.5 Other Specific Requirements

Doors must have high security hasps and may need an intrusion detection system per **AFI 31-101**.

ARCHIVED



Location: General, Air Force
Command: None
Facility Number: AF Drawing 33-39-03
Date Constructed: None

Design
 • The facility has a rocket test chamber

Facility Overview

This multi-bay facility supports rocket assembly, inspection, testing, and maintenance operations. Testing involves the electrical evaluation of rockets. The building can also be used as a storage site for built-up rockets. Since the advent of the MK 66 rocket, electrical continuity testing of rocket motors is rare and this type of facility is generally used for other purposes.

Space Usage

Size (Total) 11,615 sq ft (1,079 m²)

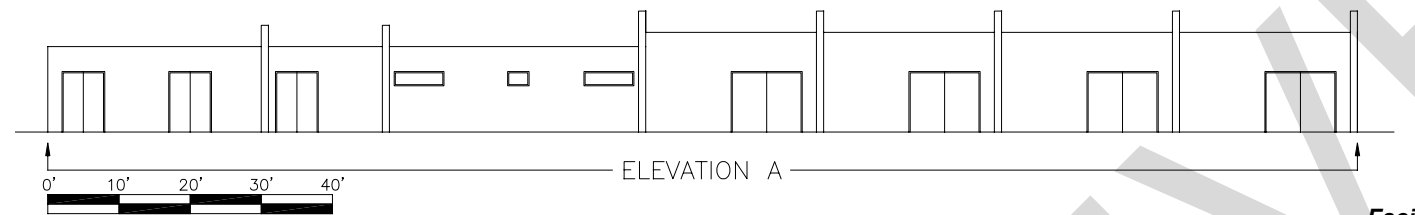

Facility Elevation

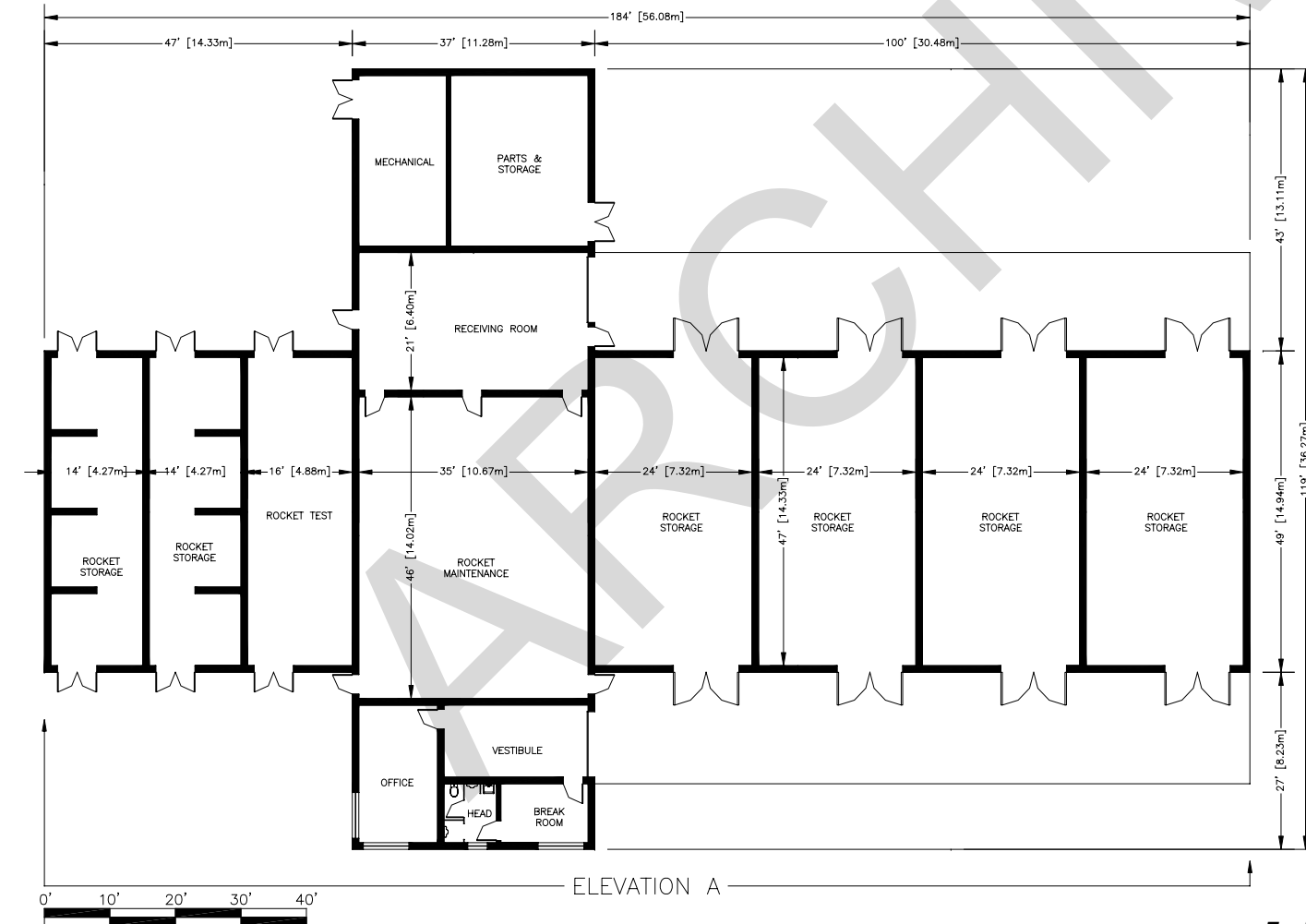

Facility Floor Plan

Category Code 422-256

Rocket Check Out and Assembly Storage

Design Related to Aircraft Type
 Aircraft Type:
 Primary Aircraft:

Stand Alone Facility
 Consolidated Facility
 Other Uses:

Single Wing
 Multiple Wings

Structural	<ul style="list-style-type: none"> Facility size measures 11,615 sq ft (1,079 m²) including area for field office Provide 12-in (304.8mm) thick reinforced interior/exterior concrete walls 2,500 psig (17,167 kPa) Provide 3/8-in (9.5mm) thick steel doors; width and height based on type of munitions supported at location Latrine facilities are optional
Electrical	<ul style="list-style-type: none"> Provide UL-approved lighting for aircraft hangars Provide explosive-proof lights per AFMAN 91-201
Fire/Safety	<ul style="list-style-type: none"> Provide lightning and surge protection per NFPA 780, MIL HDBK 419, and AFMAN 91-201 Provide grounding system per AFI 32-1065 Provide blast-resistant windows as needed
Force Protection	<ul style="list-style-type: none"> Provide high security hasps Provide intrusion detection system per AFI 31-101
Equipment	<ul style="list-style-type: none"> No specific requirements noted

Other References:

- AFH 32-1084 – Facilities Requirements
- AFMAN 91-201 – Explosives Safety Standards
- AFI 31-101 – The Physical Security Program
- DoD 6055.9 STD – DoD Ammunition and Explosives Safety Standards

ARCHIVED

Please see the next page.



Figure 4.17
Segregated Magazine
Storage -
Langley AFB, VA



Figure 4.18
Segregated Magazine
Storage -
Luke AFB, AZ



Figure 4.19
Segregated Magazine
Storage -
McChord AFB, WA

4.3.3 Category Code 422-257 Segregated Magazine Storage

Segregated magazines are a category of above ground munitions storage magazines very similar to multi-cubicle magazines used to store small quantities of explosives. Because of their small size and separation of adjoining bays, they are ideal for segregating incompatible hazard classes and explosives groups and for supporting munitions custody account customers. Each cubicle in a segregated magazine is generally a small storage locker, with a door width not exceeding 36 in (914 mm), and is usually inaccessible by most munitions support equipment.

4.3.3.1 Facility-Specific Construction Requirements

Interior dividing walls should be a minimum of 12 in (304.8 mm) thick reinforced concrete. Dividing walls between storage bays should have a compressive strength of 2,500 psig (17,170 kPa). Propagation protection for other storage bays should be provided between bays as outlined for concurrent operations in [AFMAN 91-201](#) and [TM 5-1300/AFM 88-22](#).

4.3.3.2 Facility-Specific Spatial Requirements

Facility size and number of bays dependent upon mission requirements.

4.3.3.3 Facility-Specific Mechanical Requirements

May require HVAC for climate control depending on assets to be stored and local climate conditions.

4.3.3.4 Facility-Specific Electrical Requirements

Provide grounding, surge protection, and LPS.

May require electrical outlets and interior/exterior lighting as described in [TM 5-811](#) and [AFMAN 91-201](#).

4.3.3.5 Other Specific Requirements

1. Doors must have high security hasps and may need an intrusion detection system per [AFI 31-101](#).
2. Facility doors will be made of steel and may be hinged, sliding, or roll-up type.
3. Apron in front of doors must be large enough to permit safe operation of munitions support equipment.



Please see the next page.

ARCHIVED



Location: Eglin AFB, Florida
Command: ACC
Facility Number: 1251
Date Constructed: 1977

Facility Overview

This facility provides space for the storage of small quantities of explosives material. The segregated areas are ideal for separating incompatible munitions groups and custody account assets.

Design

- Multiple small bays with hinged metal doors
- Security alarms installed
- Eight segregated areas for separating munitions
- Note: Facility layout may be tailored to accommodate the standoff distances required for storing mass detonating explosives by creating wider bays

Space Usage

Size (Total) 543 sq ft (50.45m²)



Segregated Storage Facility



Facility Apron

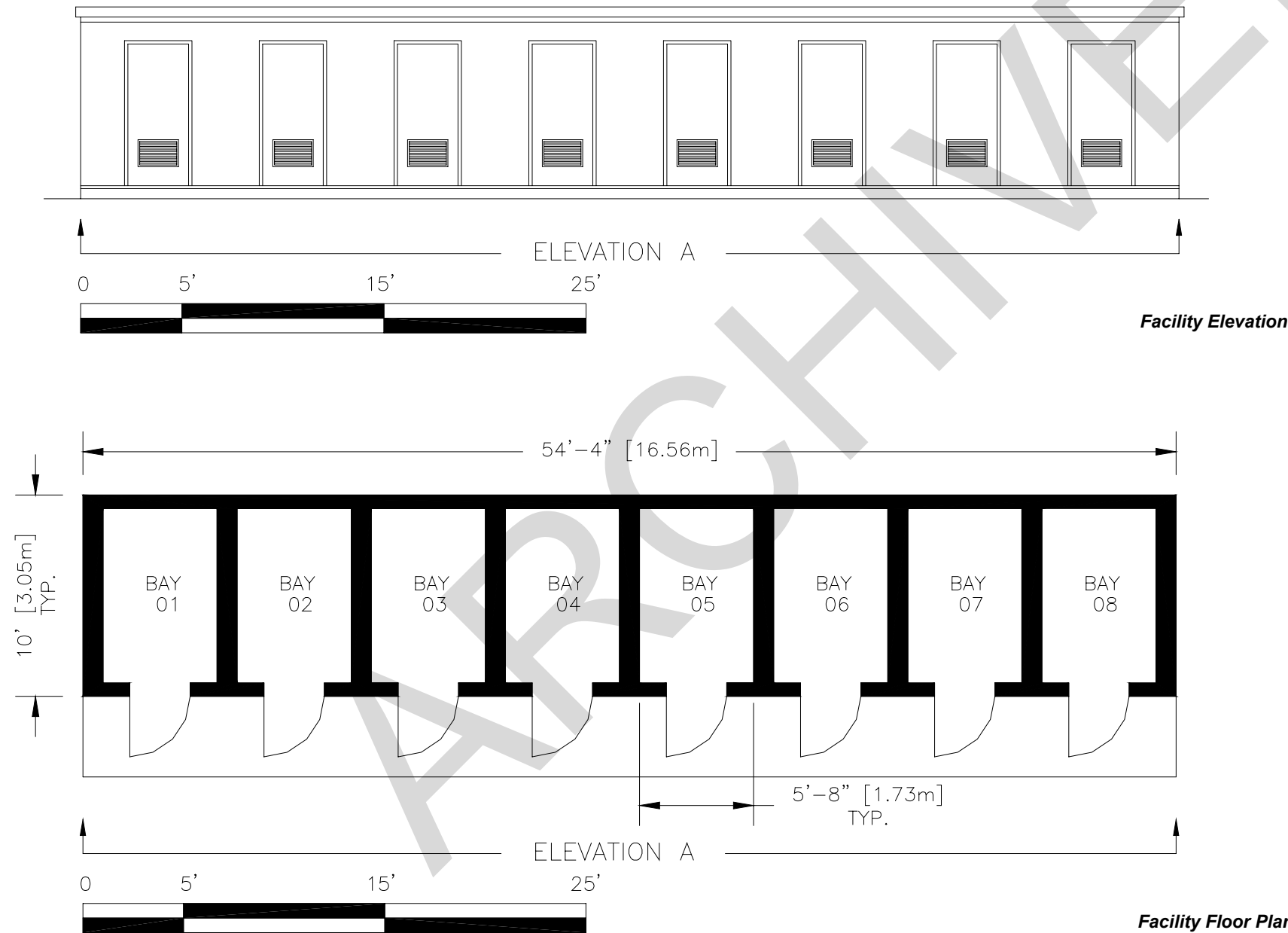

Category Code 422-257

Segregated Magazine Storage

- Design Related to Aircraft Type**
 Aircraft Type: Multiple
 Primary Aircraft: Multiple

- Stand Alone Facility**
 Consolidated Facility
 Other Uses:

- Single Wing**
 Multiple Wings

Structural	<ul style="list-style-type: none"> • Facility size and number of bays based on mission requirements • Provide 12 in (304.8mm) thick reinforced interior/exterior concrete walls 2,500 psig (17,170 kPa) • Design exterior apron/pavement and composition to accommodate MMHE • Facility doors shall be made of steel and 36 in (914.4 mm) wide and may be hinged, sliding, or roll-up type
Electrical	<ul style="list-style-type: none"> • Electrical service to building per AFMAN 91-201 and NFPA 780 • Provide UL-approved lighting in areas where explosives vapor or dust hazard are not present • Provide explosive-proof lights per AFMAN 91-201 • May require electrical outlets and interior/exterior lighting
Fire/Safety	<ul style="list-style-type: none"> • Provide lightning and surge protection per NFPA 780, MIL HDBK 419, and AFMAN 91-201 • If required, provide barricades per AFMAN 91-201 • Barricade wall must meet two-degree rule, and must be 3 ft (914.4mm) wide at top in accordance with AFMAN 91-201
Force Protection	<ul style="list-style-type: none"> • Provide high security hasps and intrusion detection system per AFI 31-101 • Install exterior security lighting based on local threat assessment
Equipment	<ul style="list-style-type: none"> • May require climate control dependent on munitions type and local climate HVAC details

Other References:

- AFH 32-1084 – Facilities Requirements
- AFMAN 91-201 – Explosives Safety Standards
- AFI 31-101 – The Physical Security Program
- DoD 6055.9 STD – DoD Ammunition and Explosives Safety Standards

ARCHIVED

Please see the next page.

Location: Shaw AFB, South Carolina
Command: ACC
Facility Number: 1822
Date Constructed: 1983

Facility Overview

This facility provides space for the storage of small quantities of explosives material. The segregated areas are ideal for separating incompatible munitions groups and custody account assets.

Design

- Multiple small bays with hinged metal doors
- Security alarms installed
- 16 segregated areas for separating munitions
- Note: Facility layout may be tailored to accommodate the standoff distances required for storing mass detonating explosives by creating wider bays

Space Usage

Size (Total) 1,080 sq ft (100.34m²)



Segregated Storage Facility

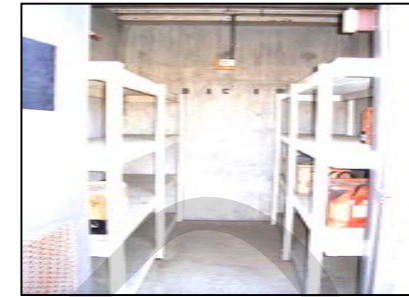

Interior Shelving Units

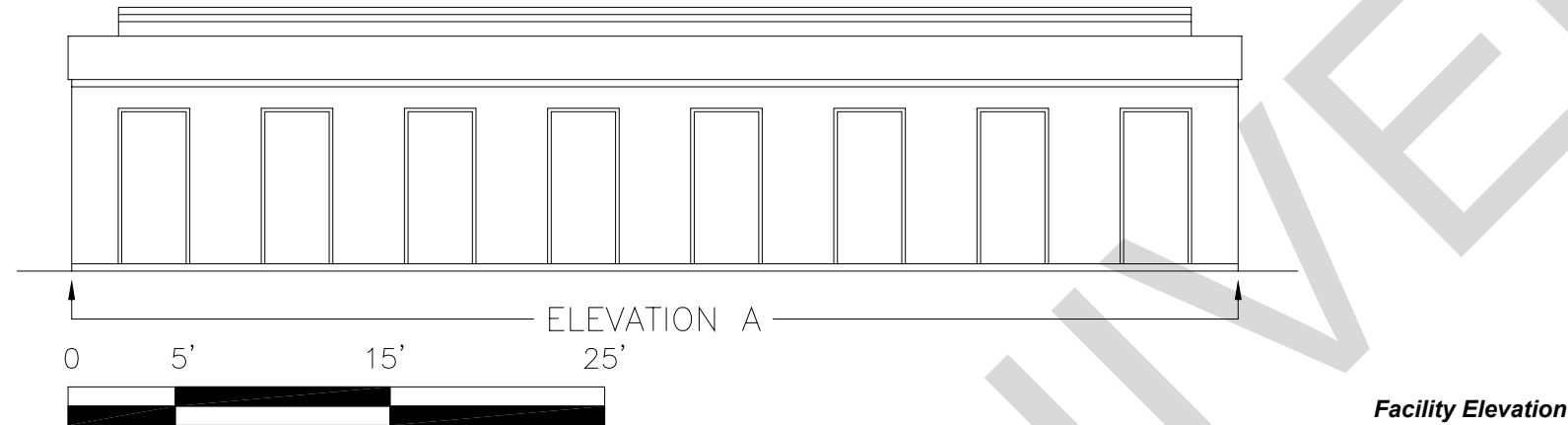

Facility Elevation

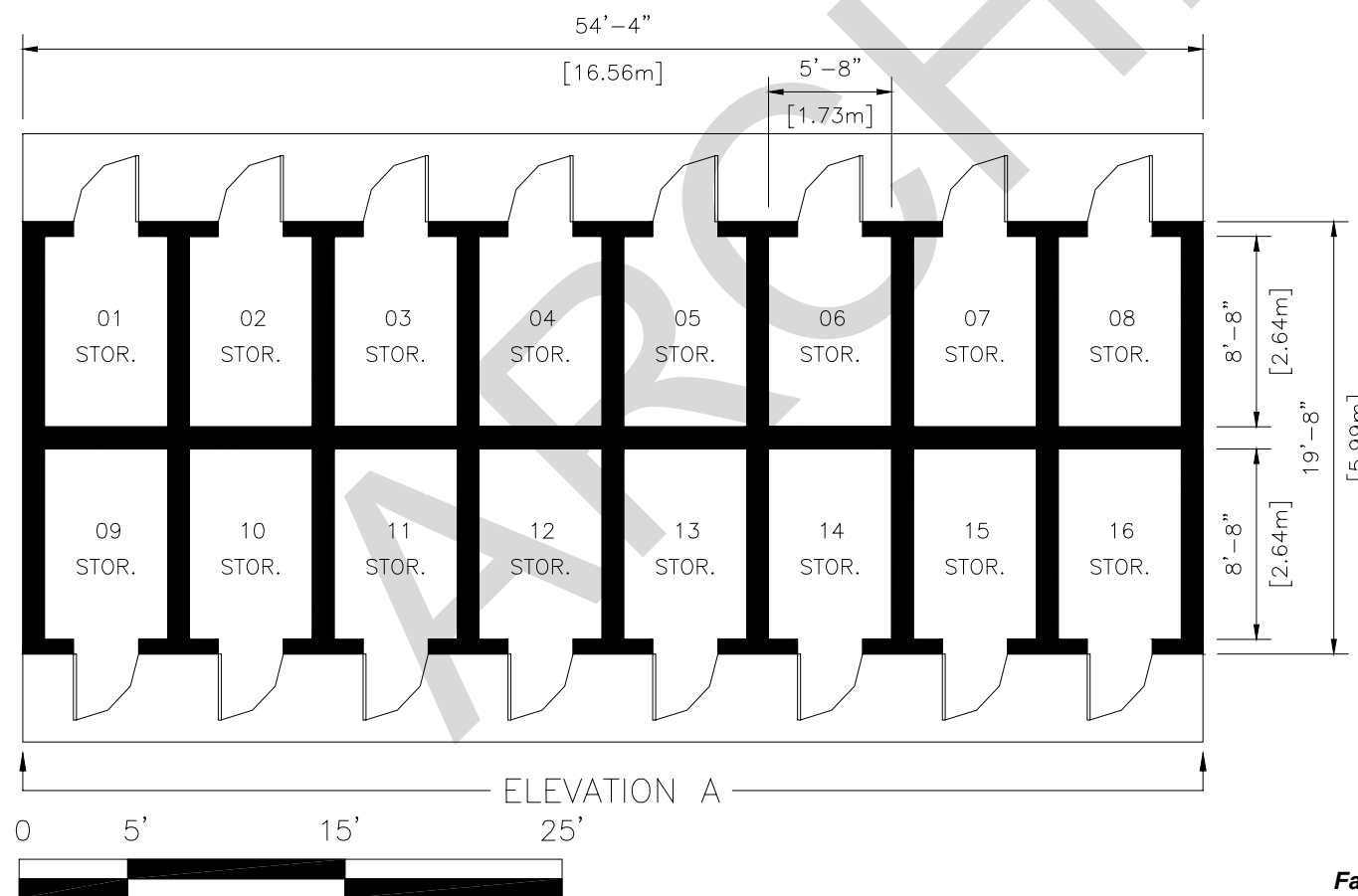

Facility Floor Plan

Category Code 422-257

Segregated Magazine Storage

- Design Related to Aircraft Type**
Aircraft Type: Fighter
Primary Aircraft: F-16

- Stand Alone Facility**
- Consolidated Facility**
- Other Uses:**

- Single Wing**
- Multiple Wings**

Structural	<ul style="list-style-type: none"> • Facility size and number of bays based on mission requirements • Provide 12 in (304.8mm) thick reinforced interior/exterior concrete walls 2,500 psig (17,170 kPa) • Design exterior apron/pavement and composition to accommodate MMHE • Facility doors shall be made of steel and 36 in (914.4 mm) wide and may be hinged, sliding, or roll-up type
Electrical	<ul style="list-style-type: none"> • Electrical service to building per AFMAN 91-201 and NFPA 780 • Provide UL-approved lighting in areas where explosives vapor or dust hazard are not present • Provide explosive-proof lights per AFMAN 91-201 • May require electrical outlets and interior/exterior lighting
Fire/Safety	<ul style="list-style-type: none"> • Provide lightning and surge protection per NFPA 780, MIL HDBK 419, and AFMAN 91-201 • If required, provide barricades per AFMAN 91-201 • Barricade wall must meet two degree rule, and must be 3 ft (914.4mm) wide at top in accordance with AFMAN 91-201
Force Protection	<ul style="list-style-type: none"> • Provide high security hasps and intrusion detection system per AFI 31-101 • Install exterior security lighting based on local threat assessment
Equipment	<ul style="list-style-type: none"> • May require climate control dependent on munitions type and local climate HVAC details

- Other References:**
- AFH 32-1084 – Facilities Requirements
 - AFMAN 91-201 – Explosives Safety Standards
 - AFI 31-101 – The Physical Security Program
 - DoD 6055.9 STD – DoD Ammunition and Explosives Safety Standards

ARCHIVED

Please see the next page.



Figure 4.20
Above Ground Magazine
Storage -
Cannon AFB, NM



Figure 4.21
Above Ground Magazine
Storage -
Luke AFB, AZ

4.3.4

Category Code 422-258

Above Ground Magazine Storage

Above ground munitions storage magazines are used to store explosives. They do not afford the same degree of protection as an earth-covered magazine (ECM) and therefore require a greater Q-D to ensure the proper degree of protection for exposed sites and personnel.

4.3.4.1 Facility-Specific Construction Requirements

Above ground magazines may be made of any type of non-combustible material (e.g., metal, concrete, clay tile, cinder block, etc.) or may even consist of just an open pad.

4.3.4.2 Facility-Specific Spatial Requirements

1. The magazines may vary in size from 1,800 sq ft to 10,000 sq ft (167 m² to 918 m²) depending upon the volume of munitions to be stored.
2. Refer to Unit's Master Storage Plan, [DDESB TP-15](#), *Approved Protective Construction (Version 1.0)*, [DoD 6055.9-STD](#), and [AFMAN 91-201](#) for further guidance on storage space requirements.

4.3.4.3 Facility-Specific Mechanical Requirements

May require HVAC for climate control depending on assets to be stored and local climate conditions.

4.3.4.4 Facility-Specific Electrical Requirements

1. Provide grounding, surge protection, and LPS.
2. May require electrical outlets and interior/exterior lighting as described in [TM 5-811](#) and [AFMAN 91-201](#).

4.3.4.5 Other Specific Requirements

1. Doors require high security hasps and may need an intrusion detection system per [AFI 31-101](#).
2. Facility doors will be made of steel and may be hinged, sliding, or roll-up type.
3. Apron in front of doors must be large enough to permit safe operation of munitions support equipment.



Please see the next page.

ARCHIVED



Location: Barksdale AFB, Louisiana
Command: ACC
Facility Number: 7557
Date Constructed: 1995

Facility Overview

Facility is used to store munitions of all hazard classes and divisions. Facility has ample internal overhead lighting and ventilation to mitigate regional climate effects.

- Design**
- Large, corrugated metal construction with sloped metal roof
 - Large roll-up door for vehicle/trailer entry/exit
 - Emphasis on ventilation due to regional climate

Space Usage

Size (Total) 10,000 sq ft (929.03m²)



Roll-up and Personnel Doors



Surrounding Concrete Apron



Facility Elevation

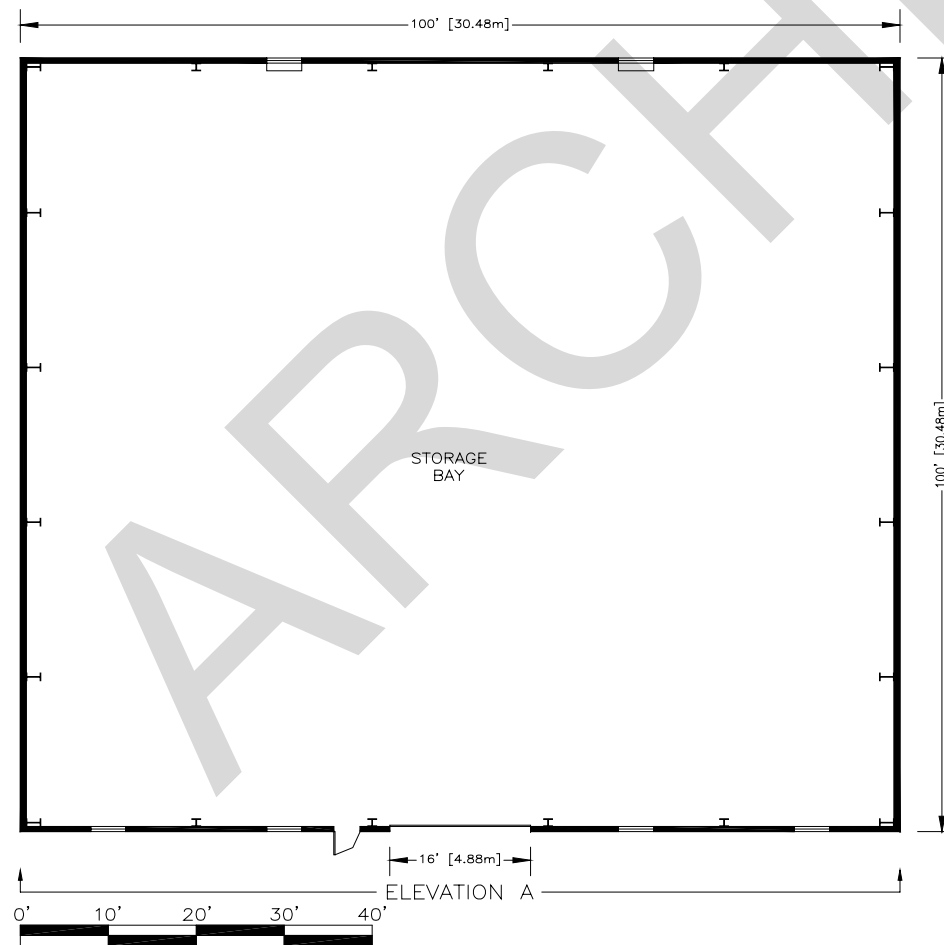

Facility Floor Plan

Category Code 422-258

Above Ground Magazine Storage

Design Related to Aircraft Type

Aircraft Type: Bomber
 Primary Aircraft: B-52

Stand Alone Facility

Consolidated Facility
Other Uses:

Single Wing

Multiple Wings

Structural

- Constructed of non-combustible material
- May vary in size from 1,800 sq ft to 10,000 sq ft (167 m² to 918m²) depending on volume of munitions to be stored
- Design exterior apron/pavement and composition to accommodate assigned weapon system(s) and MMHE
- Provide steel doors sufficient to accommodate size of assigned munitions weapon system(s)

Electrical

- Electrical service to the building (if required) must be buried underground per AFMAN 91-201
- Provide explosive-proof lights per AFMAN 91-201 where explosive vapors are present
- Provide UL-approved lighting fixtures in areas where explosive proof lighting is not required.
- May require electrical outlets and interior/exterior lighting

Fire/Safety

- Provide lightning and surge protection per NFPA 780, MIL HDBK 419, and AFMAN 91-201
- If required, provide barricades per AFMAN 91-201
- Barricade wall must meet two degree rule, and must be 3 ft (914.4 mm) wide at top in accordance with AFMAN 91-201

Force Protection

- Provide high security hasps and intrusion detection system per AFI 31-101
- Install exterior security lighting based on local threat assessment

Equipment

- May require climate control dependent on munitions type and local climate HVAC details

Other References:

- AFH 32-1084 – *Facilities Requirements*
- AFMAN 91-201 – *Explosives Safety Standards*
- AFI 31-101 – *The Physical Security Program*
- DoD 6055.9 STD – *DoD Ammunition and Explosives Safety Standards*

ARCHIVED

Please see the next page.

Location: Cannon AFB, New Mexico
Command: ACC
Facility Number: 2147
Date Constructed: 1988

Design

- Large, barrel roof ribbed metal construction K-span
- Flow-through access
- Large roll-up doors for vehicle/trailer entry/exit

Facility Overview

Facility is used to store munitions of all hazard classes and divisions. May be used to store Ready Munitions loaded on trailers. Facility has ample internal overhead lighting.

Space Usage

Size (Total) 5,000 sq ft (464.52m²)



Roll-up and Personnel Doors



Unobstructed Center Aisle

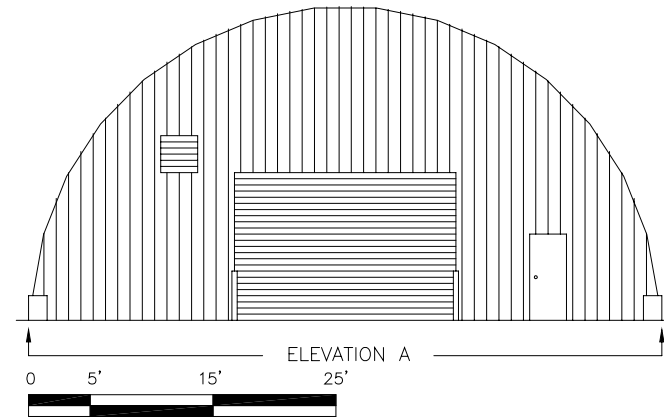

Facility Elevation

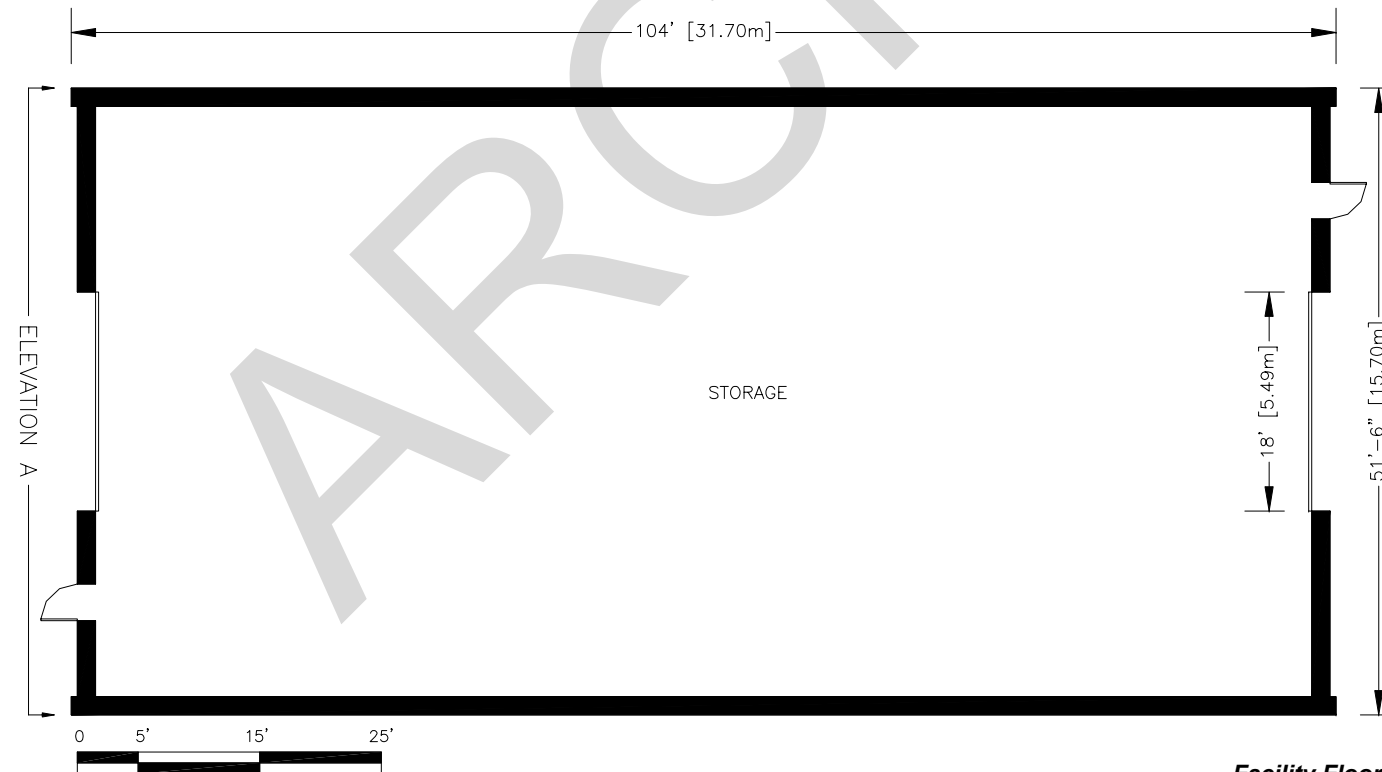

Facility Floor Plan

Category Code 422-258
Above Ground Magazine Storage

Design Related to Aircraft Type
 Aircraft Type: Fighter
 Primary Aircraft: F-16

Stand Alone Facility
 Consolidated Facility
Other Uses:

Single Wing
 Multiple Wings

Structural	<ul style="list-style-type: none"> • Constructed of non-combustible material • May vary in size from 1,800 sq ft (167m²) to 10,000 sq ft (918m²) depending on volume of munitions to be stored • Design exterior apron/pavement and composition to accommodate assigned weapon system(s) and MMHE • Provide steel doors sufficient to accommodate size of assigned munitions weapon system(s)
Electrical	<ul style="list-style-type: none"> • Electrical service to the building (if required) must be buried underground per AFMAN 91-201 • Provide explosive-proof lights per AFMAN 91-201 where explosive vapors are present • Provide UL-approved lighting fixtures in areas where explosive proof lighting is not required. • May require electrical outlets and interior/ exterior lighting
Fire/Safety	<ul style="list-style-type: none"> • Provide lightning and surge protection per NFPA 780, MIL HDBK 419, and AFMAN 91-201 • If required, provide barricades per AFMAN 91-201 • Barricade wall must meet two degree rule, and must be 3 ft (914.4mm) wide at top in accordance with AFMAN 91-201
Force Protection	<ul style="list-style-type: none"> • Provide high security hasps and intrusion detection system per AFI 31-101 • Install exterior security lighting based on local threat assessment
Equipment	<ul style="list-style-type: none"> • May require climate control dependent on munitions type and local climate HVAC details

Other References:

- AFH 32-1084 – *Facilities Requirements*
- AFMAN 91-201 – *Explosives Safety Standards*
- AFI 31-101 – *The Physical Security Program*
- DoD 6055.9 STD – *DoD Ammunition and Explosives Safety Standards*

ARCHIVED

Please see the next page.

Category Code 422-258 Above Ground Magazine Storage

Location: Eglin AFB, Florida
Command: ACC
Facility Number: 1290
Date Constructed: 1986

Facility Overview

Facility is used to store munitions of all hazard classes. May be used to store Ready Munitions loaded on trailers. Facility has ample internal overhead lighting and electrical outlets.

Design

- Large unobstructed interior space
- Large surrounding apron to support GOV and MMHE usage
- Eight wide roll-up doors enhance the ingress and egress of over-sized containers, vehicles, and trailers
- Multiple doors provide direct access that allows for the use of floor space usually reserved for maneuvering equipment inside the facility

Space Usage

Size (Total) 10,000 sq ft (929.03m²)



Exterior View



Large Surrounding Apron

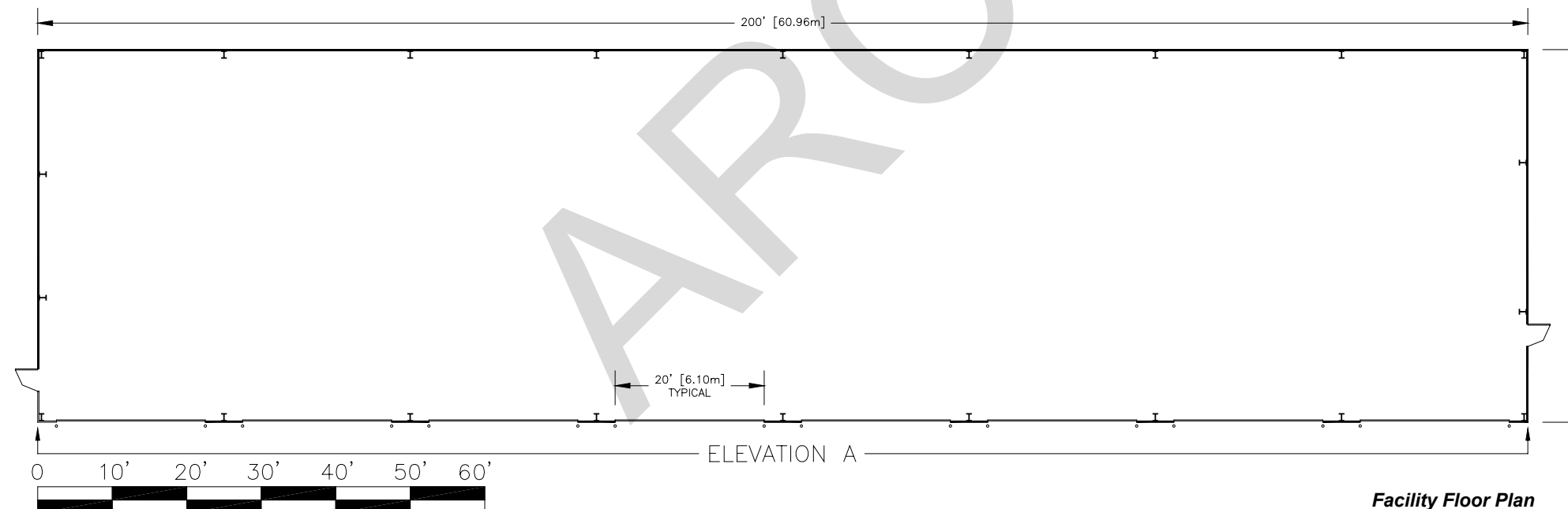
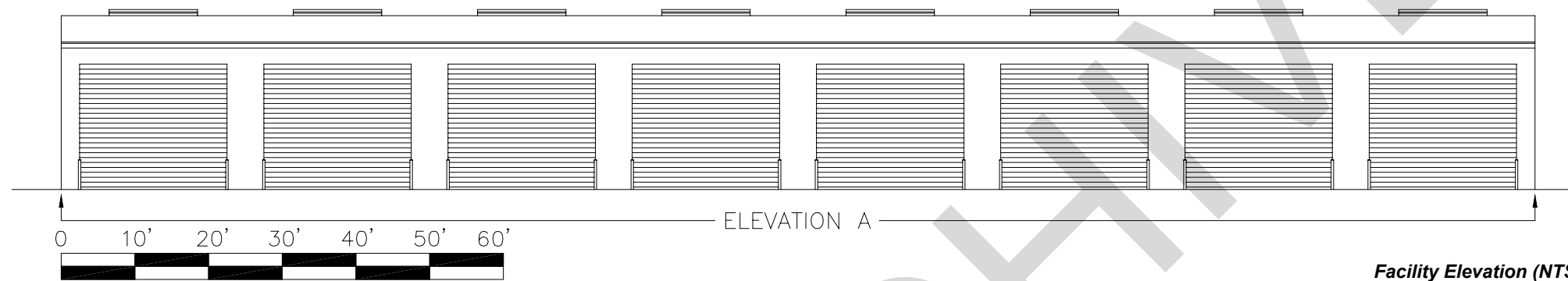

Design Related to Aircraft Type

Aircraft Type: Fighter
 Primary Aircraft: F-16

Stand Alone Facility

Consolidated Facility
 Other Uses:

Single Wing

Multiple Wings

Structural	<ul style="list-style-type: none"> • Constructed of non-combustible material • May vary in size from 1,800 sq ft (167m²) to 10,000 sq ft (918m²) depending on volume of munitions to be stored • Design exterior apron/pavement and composition to accommodate assigned weapon system(s) and MMHE • Provide steel doors sufficient to accommodate size of assigned munitions weapon system(s)
Electrical	<ul style="list-style-type: none"> • Electrical service to the building (if required) must be buried underground per AFMAN 91-201 • Provide explosive-proof lights per AFMAN 91-201 where explosive vapors are present • Provide UL-approved lighting fixtures in areas where explosive proof lighting is not required. • May require electrical outlets and interior/exterior lighting
Fire/Safety	<ul style="list-style-type: none"> • Provide lightning and surge protection per NFPA 780, MIL HDBK 419, and AFMAN 91-201 • If required, provide barricades per AFMAN 91-201 • Barricade wall must meet two degree rule and must be 3 ft (914.4mm) wide at top in accordance with AFMAN 91-201
Force Protection	<ul style="list-style-type: none"> • Provide high security hasps and intrusion detection system per AFI 31-101 • Install exterior security lighting based on local threat assessment
Equipment	<ul style="list-style-type: none"> • May require climate control dependent on munitions type and local climate HVAC details

Other References:

- AFH 32-1084 – Facilities Requirements
- AFMAN 91-201 – Explosives Safety Standards
- AFI 31-101 – The Physical Security Program
- DoD 6055.9 STD – DoD Ammunition and Explosives Safety Standards

ARCHIVED

Please see the next page.

Location: McChord AFB, Washington
Command: AMC
Facility Number: 369
Date Constructed: 1986

Design

- Large unobstructed interior space
- Three large roll-up doors for vehicle/trailer entry/exit
- Surrounding apron facilitates vehicle maneuverability



Above Ground Storage Magazine



Roll-up Bay Doors with Personnel Entrances at Both Ends

Facility Overview

Facility is used to store all hazard classes/divisions of munitions. Facility has ample internal overhead lighting and ventilation to mitigate regional climate effects.

Space Usage

Size (Total) 4,100 sq ft (380.90m²)

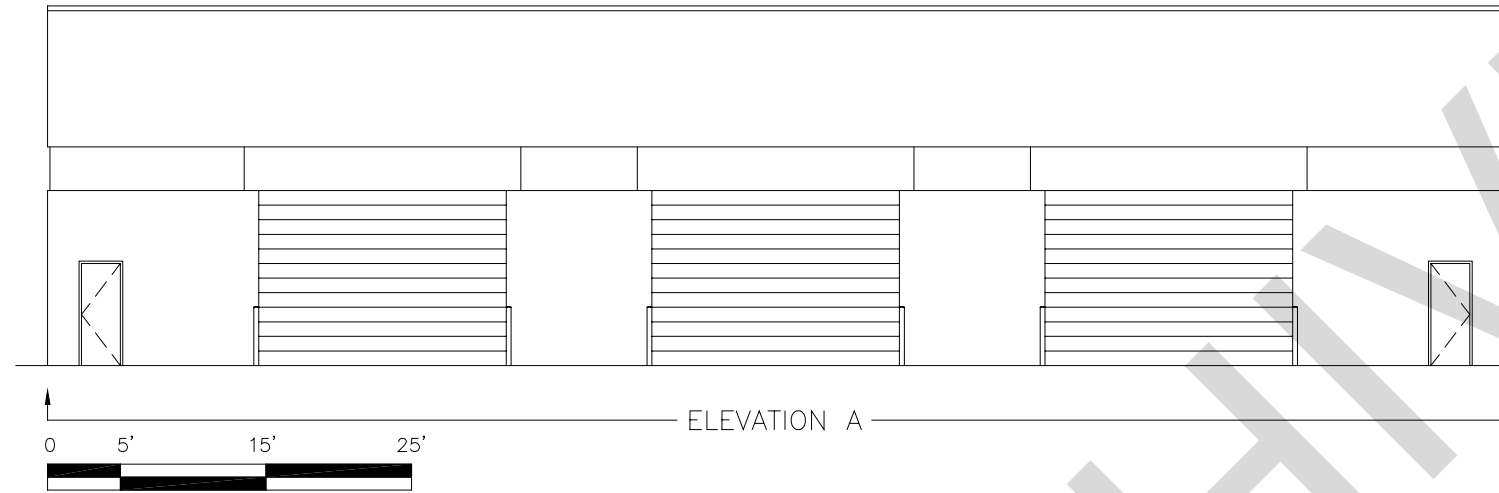

Facility Elevation

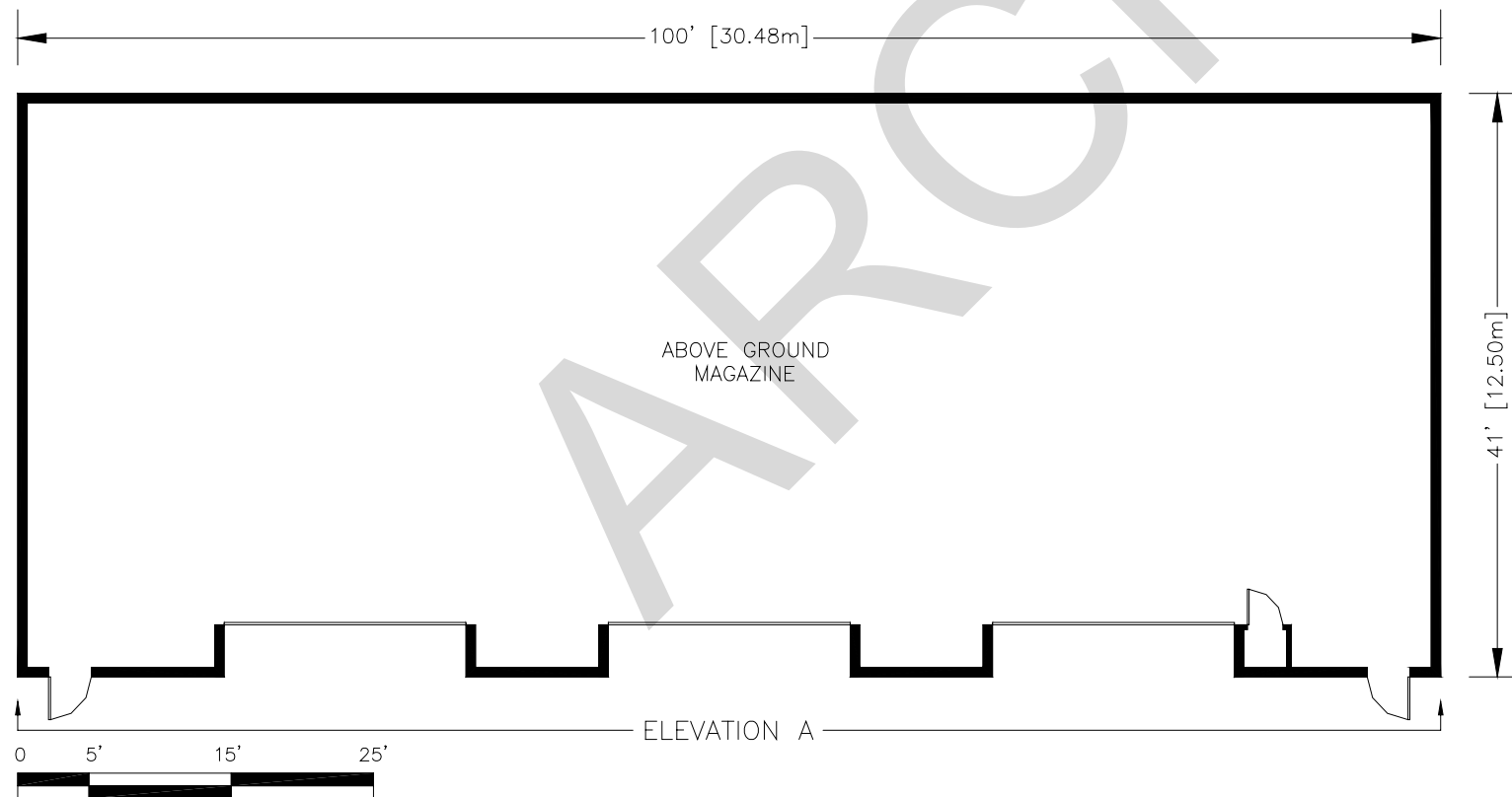

Facility Floor Plan

Category Code 422-258
Above Ground Magazine Storage

Design Related to Aircraft Type

Aircraft Type: Cargo
 Primary Aircraft: C-17

Stand Alone Facility

Consolidated Facility
Other Uses:

Single Wing

Multiple Wings

Structural	<ul style="list-style-type: none"> • Constructed of non-combustible material • May vary in size from 1,800 sq ft to 10,000 sq ft (167 m² to 918m²) depending on volume of munitions to be stored • Design exterior apron/pavement and composition to accommodate assigned weapon system(s) and MMHE • Provide steel doors sufficient to accommodate size of assigned munitions weapon system(s)
Electrical	<ul style="list-style-type: none"> • Electrical service to the building (if required) must be buried underground per AFMAN 91-201 • Provide explosive-proof lights per AFMAN 91-201 where explosive vapors are present • Provide UL-approved lighting fixtures in areas where explosive proof lighting is not required. • May require electrical outlets and interior/ exterior lighting
Fire/Safety	<ul style="list-style-type: none"> • Provide lightning and surge protection per NFPA 780, MIL HDBK 419, and AFMAN 91-201 • If required, provide barricades per AFMAN 91-201 • Barricade wall must meet two degree rule, and must be 3 ft (914.4 mm) wide at top in accordance with AFMAN 91-201
Force Protection	<ul style="list-style-type: none"> • Provide high security hasps and intrusion detection system per AFI 31-101 • Install exterior security lighting based on local threat assessment
Equipment	<ul style="list-style-type: none"> • May require climate control dependent on munitions type and local climate HVAC details

Other References:

- AFH 32-1084 – *Facilities Requirements*
- AFMAN 91-201 – *Explosives Safety Standards*
- AFI 31-101 – *The Physical Security Program*
- DoD 6055.9 STD – *DoD Ammunition and Explosives Safety Standards*

ARCHIVED

Please see the next page.



Figure 4.22
Storage Igloo -
Luke AFB, AZ

4.3.5 Category Code 422-264 Storage Igloo

Storage igloos are the preferred facility type for the storage of all explosives. They are ECMs and are either of a concrete or steel arch-type construction.

4.3.5.1 Facility-Specific Construction Requirements

1. Igloos are covered with a minimum of 24 in (610 mm) of earth covering. The earth covering must not contain stones/rocks larger than 6 in (152 mm) in diameter or weighing more than 10 lbs (4.5 kg).
2. The Munitions Storage Module (MSM), a pre-engineered concrete panel design, features vertical walls and a flat roof to maximize storage space. A 26 ft (7.9 m) wide, 14 ft (4.2 m) high door adds efficiency to warehousing operations.

4.3.5.2 Facility-Specific Spatial Requirements

1. The typical length is 80 ft (25.3 m). Variable lengths, in increments of 20 ft (6.0 m), provide flexibility to meet mission requirements. The design has been approved by DDESB for siting igloos with a maximum NEW of 500,000 lbs (227,273 kg).
2. The steel arch earth-covered igloo has a concrete floor, foundations, side arches, and a rear and front wall. The typical length is 80 ft (25.3 m) although it may be constructed in variable lengths in 2 ft (0.6 m) increments and in widths up to 30 ft (9.1 m). The arch is constructed of heavy gauge corrugated steel plates. The double leaf doors are of heavy blast-resistant steel.

4.3.5.3 Facility-Specific Mechanical Requirements

May require HVAC for climate and humidity control depending on assets to be stored and local climate conditions.

4.3.5.4 Facility-Specific Electrical Requirements

1. Provide grounding, surge protection, and LPS.
2. May require electrical outlets and interior/exterior lighting as described in [TM 5-811](#) and [AFMAN 91-201](#).

4.3.5.5 Other Specific Requirements

1. Doors require high security hasps and may need an intrusion detection system per [AFI 31-101](#).
2. Facility doors will be made of blast-resistant steel and may be hinged, rolling, or sliding type.



3. Apron in front of doors must be large enough to permit safe operation of munitions support equipment.
4. Assure adequate area and structural design of pads in front of facility.

ARCHIVED



Location: Hill AFB, Utah
Command: AFMC
Facility Number: 2522
Date Constructed: 2003

Facility Overview

This facility is used to store all types of explosives materiel. It is the preferred structure for storing mass-detonating explosives in hazard classes/divisions 1.1.

Design

- Igloos are spaced 67 ft (20.42m) apart to permit 250,000 lbs (113,400 kg) Net Explosives Weight (NEW) with future plans calling for a 100 ft (30.48m) separation to allow for 500,000 lbs (226,800 kg) NEW
- Slap bars are included
- 7-bar construction on doors
- Doors open to 25 ft (7.62m) wide to permit loading of oversized containers
- Vertical walls optimize stacking of assets

Space Usage

Size (Total) 2,046 sq ft (190.04m²)



Exterior Earth Cover



Igloo Interior

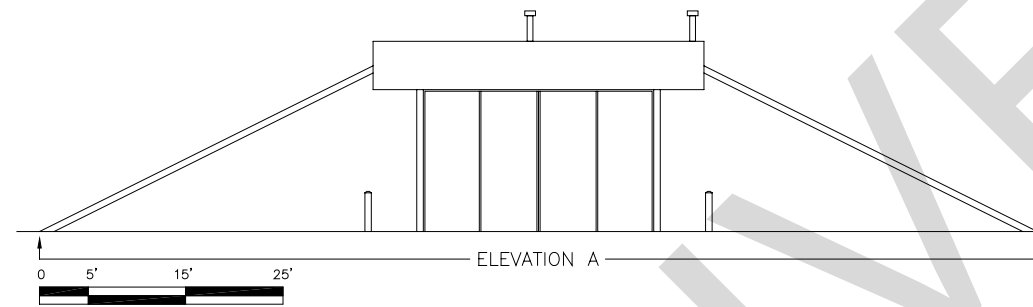

Facility Elevation

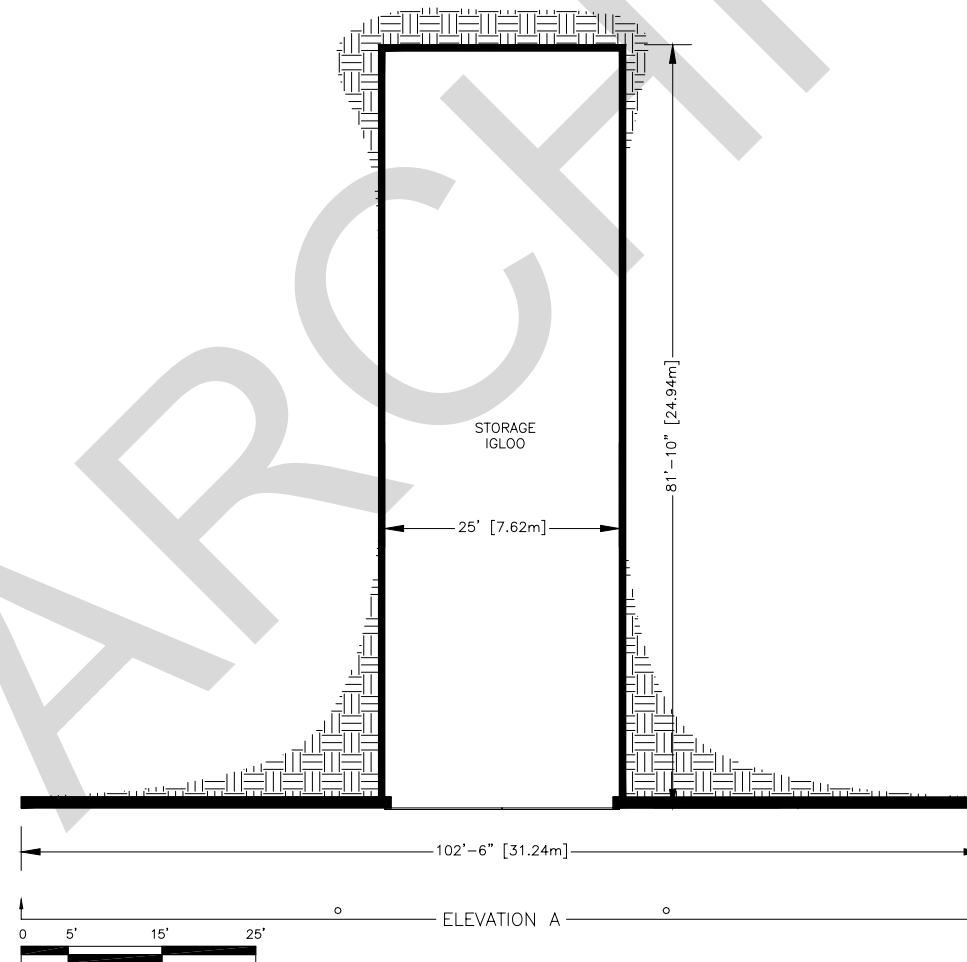

Facility Floor Plan

Category Code 422-264

Storage Igloo

- Design Related to Aircraft Type**
 Aircraft Type: Cargo and Fighter
 Primary Aircraft: C-5, C-17, F-16

- Stand Alone Facility**
- Consolidated Facility**
- Other Uses:**

- Single Wing**
- Multiple Wings**

Structural	<ul style="list-style-type: none"> • Most common facility size is 25 ft (7.62m) width x 80 ft (24.38m) length. Based on mission requirements, Hayman igloo length may vary by 20 ft (6.10m) increments. • Concrete, steel arch, or pre-cast box construction; earth cover must be a minimum of 24 in (609.6mm) • Design exterior apron/pavement and composition to accommodate weapon system and MMHE • Provide blast-resistant steel doors sufficient to accommodate size of assigned munitions weapon systems. Hayman igloos may be built with 11 ft (3.35m) – 14 ft (4.27m) tall doors of 7-bar construction.
Electrical	<ul style="list-style-type: none"> • Electrical service to building per AFMAN 91-201 and NFPA 780 • Provide UL-approved lighting in areas where explosives vapor or dust hazard are not present • Provide explosive-proof lights per AFMAN 91-201 • May require electrical outlets and interior/exterior lighting
Fire/Safety	<ul style="list-style-type: none"> • Provide lightning and surge protection per NFPA 780, MIL HDBK 419, and AFMAN 91-201 • Provide grounding system per AFI 32-1065 • If required, provide barricades per AFMAN 91-201 • Barricade wall must meet two degree rule, and must be 3 ft (914mm) wide at top in accordance with AFMAN 91-201
Force Protection	<ul style="list-style-type: none"> • Provide high security hasps and intrusion detection system per AFI 31-101 • Install exterior security lighting based on local threat assessment
Equipment	<ul style="list-style-type: none"> • May require climate control dependent on munitions type and local climate HVAC details

Other References:

- AFH 32-1084 – *Facilities Requirements*
- AFMAN 91-201 – *Explosives Safety Standards*
- AFI 31-101 – *The Physical Security Program*
- DoD 6055.9 STD – *DoD Ammunition and Explosives Safety Standards*

ARCHIVED

Please see the next page.

Category Code 422-264

Storage Igloo

Location: Shaw AFB, South Carolina
Command: ACC
Facility Number: 1892
Date Constructed: 2002

Facility Overview

This facility is used to store all types of explosive materials. It is the preferred structure for storing mass-detonating explosives in hazard class/division 1.1.

Design

- Slap bars are included
- Facility depth is 40 ft (12.19m²) to accommodate a specific mission
- Doors open to 25 ft (7.62m) width to permit loading of oversized containers
- Vertical walls optimize stacking of assets

Space Usage

Size (Total) 924 sq ft (85.66m²)



Storage Igloo



Igloo Interior

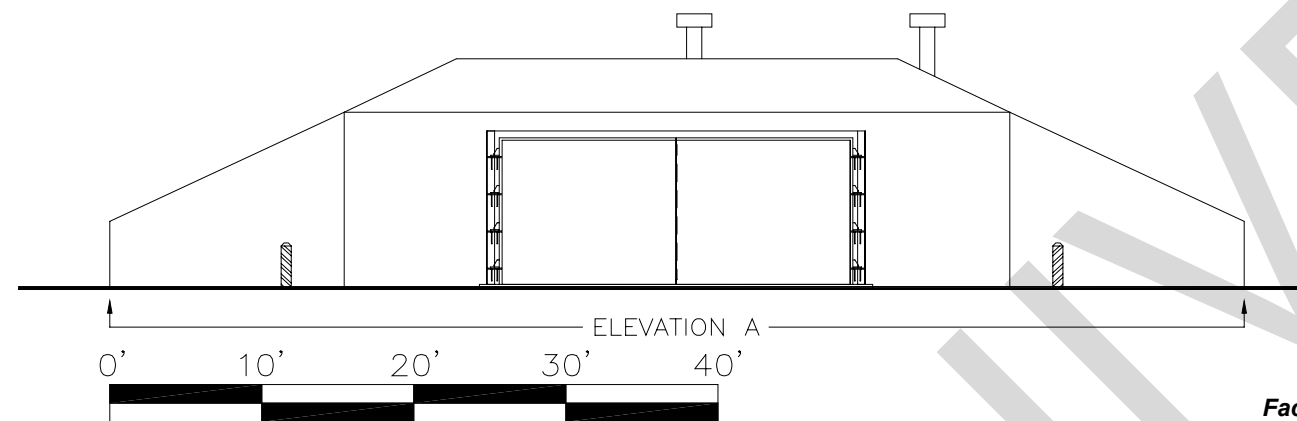

Facility Elevation

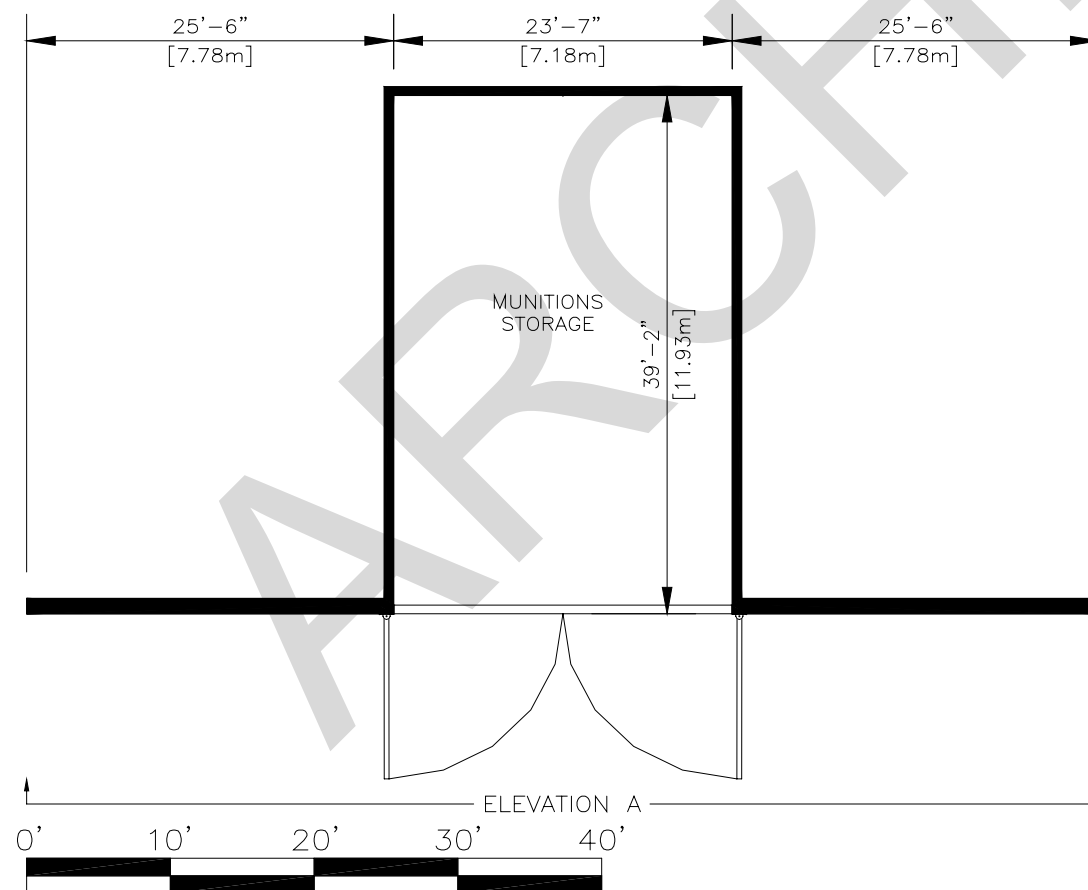

Facility Floor Plan

Design Related to Aircraft Type

Aircraft Type: Fighter
 Primary Aircraft: F-16

Stand Alone Facility

Consolidated Facility

Other Uses:

Single Wing

Multiple Wings

Structural	<ul style="list-style-type: none"> • Most common facility size is 25 ft (7.62m) width x 80 ft (24.38m) length. Based on mission requirements Hayman igloo length may vary by 20 ft (6.10m) increments. • Concrete, steel arch, or pre-cast box construction; earth cover must be a minimum of 24 in (609.6mm) • Design exterior apron/pavement and composition to accommodate weapon system and MMHE • Provide blast-resistant steel doors sufficient to accommodate size of assigned munitions weapon systems. Hayman igloos may be built with 11 ft (3.35m) – 14 ft (4.27m) tall doors of 7-bar construction.
Electrical	<ul style="list-style-type: none"> • Electrical service to building per AFMAN 91-201 and NFPA 780 • Provide UL-approved lighting in areas where explosives vapor or dust hazard are not present • Provide explosive-proof lights per AFMAN 91-201 • May require electrical outlets and interior/exterior lighting
Fire/Safety	<ul style="list-style-type: none"> • Provide lightning and surge protection per NFPA 780, MIL HDBK 419, and AFMAN 91-201 • Provide grounding system per AFI 32-1065 • If required, provide barricades per AFMAN 91-201 • Barricade wall must meet two degree rule, and must be 3 ft (914mm) wide at top in accordance with AFMAN 91-201
Force Protection	<ul style="list-style-type: none"> • Provide high security hasps and intrusion detection system per AFI 31-101 • Install exterior security lighting based on local threat assessment
Equipment	<ul style="list-style-type: none"> • May require climate control dependent on munitions type and local climate HVAC details

Other References:

- AFH 32-1084 – Facilities Requirements
- AFMAN 91-201 – Explosives Safety Standards
- AFI 31-101 – The Physical Security Program
- DoD 6055.9 STD – DoD Ammunition and Explosives Safety Standards

ARCHIVED

Please see the next page.

Location: Whiteman AFB, Missouri
Command: ACC
Facility Number: 4037
Date Constructed: 2002

Facility Overview

This facility is used to store all types of explosives material. It is the preferred structure for storing mass-detonating explosives in hazard class/division 1.1.

Design

- Doors open to 25 ft (7.62m) wide to permit storage of oversized containers and loaded trailers
- Vertical walls optimize stacking of assets
- Large surrounding apron facilitates maneuvering of trailers and equipment

Space Usage

Size (Total) 2,046 sq ft (190.04m²)



Large Surrounding Apron



Igloo Interior

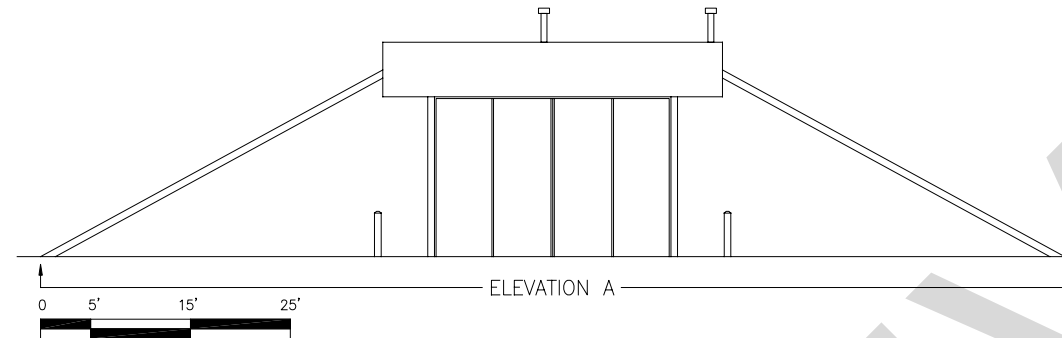

Facility Elevation

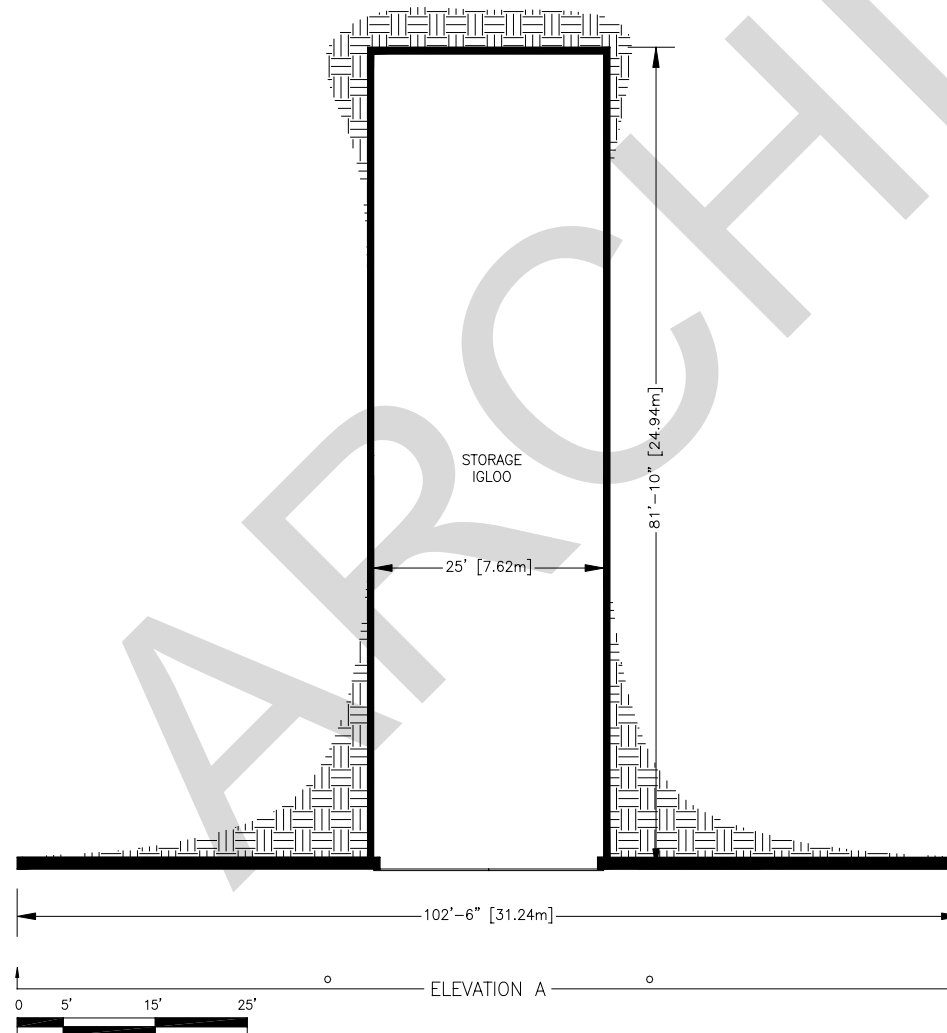

Facility Floor Plan

Category Code 422-264

Storage Igloo

- Design Related to Aircraft Type**
 Aircraft Type: Bomber
 Primary Aircraft: B-2

- Stand Alone Facility**
- Consolidated Facility**
- Other Uses:**

- Single Wing**
- Multiple Wings**

Structural	<ul style="list-style-type: none"> • Most common facility size is 25 ft (7.62m) width x 80 ft (24.38m) length. Based on mission requirements, Hayman igloo length may vary by 20 ft (6.10m) increments. • Concrete, steel arch, or pre-cast box construction; earth cover must be a minimum of 24 in (609.6mm) • Design exterior apron/pavement and composition to accommodate weapon system and MMHE • Provide blast-resistant steel doors sufficient to accommodate size of assigned munitions weapon systems. Hayman igloos may be built with 11 ft (3.35m) – 14 ft (4.27m) tall doors of 7-bar construction.
Electrical	<ul style="list-style-type: none"> • Electrical service to building per AFMAN 91-201 and NFPA 780 • Provide UL-approved lighting in areas where explosives vapor or dust hazard are not present • Provide explosive-proof lights per AFMAN 91-201 • May require electrical outlets and interior/exterior lighting
Fire/Safety	<ul style="list-style-type: none"> • Provide lightning and surge protection per NFPA 780, MIL HDBK 419, and AFMAN 91-201 • Provide grounding system per AFI 32-1065 • If required, provide barricades per AFMAN 91-201 • Barricade wall must meet two degree rule, and must be 3 ft (914mm) wide at top in accordance with AFMAN 91- 201
Force Protection	<ul style="list-style-type: none"> • Provide high security hasps and intrusion detection system per AFI 31-101 • Install exterior security lighting based on local threat assessment
Equipment	<ul style="list-style-type: none"> • May require climate control dependent on munitions type and local climate HVAC details

Other References:

- AFH 32-1084 – *Facilities Requirements*
- AFMAN 91-201 – *Explosives Safety Standards*
- AFI 31-101 – *The Physical Security Program*
- DoD 6055.9 STD – *DoD Ammunition and Explosives Safety Standards*

ARCHIVED

Please see the next page.



Figure 4.23
Inert Spares Storage -
Luke AFB, AZ



Figure 4.24
Inert Spares Storage -
Langley AFB, VA

4.3.6 Category Code 422-265 Inert Spares Storage

This building is used to store inert munitions components (e.g. inert bombs, fins, empty containers, chaff), materials, and support equipment (e.g., MMHE, AME).

4.3.6.1 Facility-Specific Construction Requirements

Inert storage facilities are made of any type of non-combustible material (e.g., metal, concrete, clay tile, cinder block, etc.) or may even consist of just an open pad.

4.3.6.2 Facility-Specific Spatial Requirements

1. Required floor space can be computed using the MSA's Unit Master Storage Plan.
2. Any facility may be used as an inert storage facility provided it meets Q-D requirements per [AFMAN 91-201](#).

4.3.6.3 Facility-Specific Mechanical Requirements

May require HVAC for climate and humidity control depending on assets to be stored and local climate conditions.

4.3.6.4 Facility-Specific Electrical Requirements

1. Provide grounding, surge protection, and LPS.
2. May require electrical outlets and interior/exterior lighting as described in [TM 5-811](#).

4.3.6.5 Other Specific Requirements

1. Doors may require high security hasps and may need an intrusion detection system per [AFI 31-101](#).
2. Facility doors will be made of steel and may be hinged, sliding, or roll-up type.
3. Apron in front of doors must be large enough to permit safe operation of munitions support equipment.



Please see the next page.

ARCHIVED



Location: Seymour-Johnson AFB
North Carolina
Command: ACC
Facility Number: 2220
Date Constructed: 1997

Facility Overview
This facility is used to store all types of inert munitions components, support equipment, and materials.

Design

- Roll-up bay doors allow for flow-through traffic
- Required interior lighting provided
- Tight weatherproof construction prevents leaks and pest infestation

Space Usage
Size (Total) 5,000 sq ft (464.52m²)



Surrounding Apron



Unobstructed Space for Maneuvering Equipment

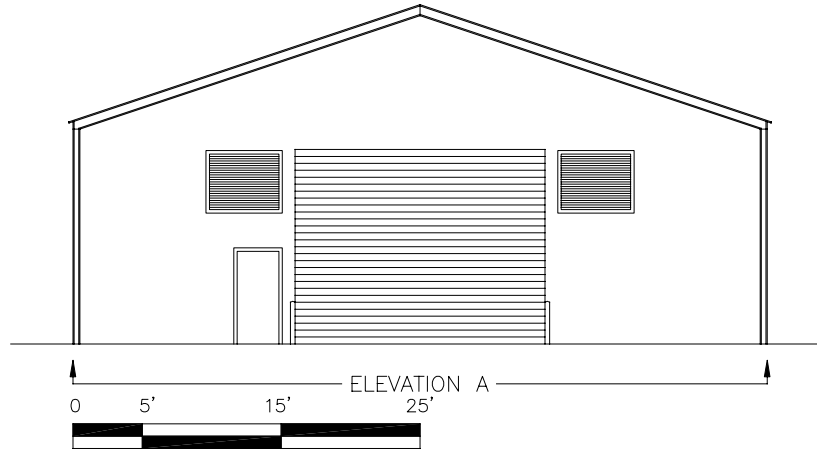

Facility Elevation

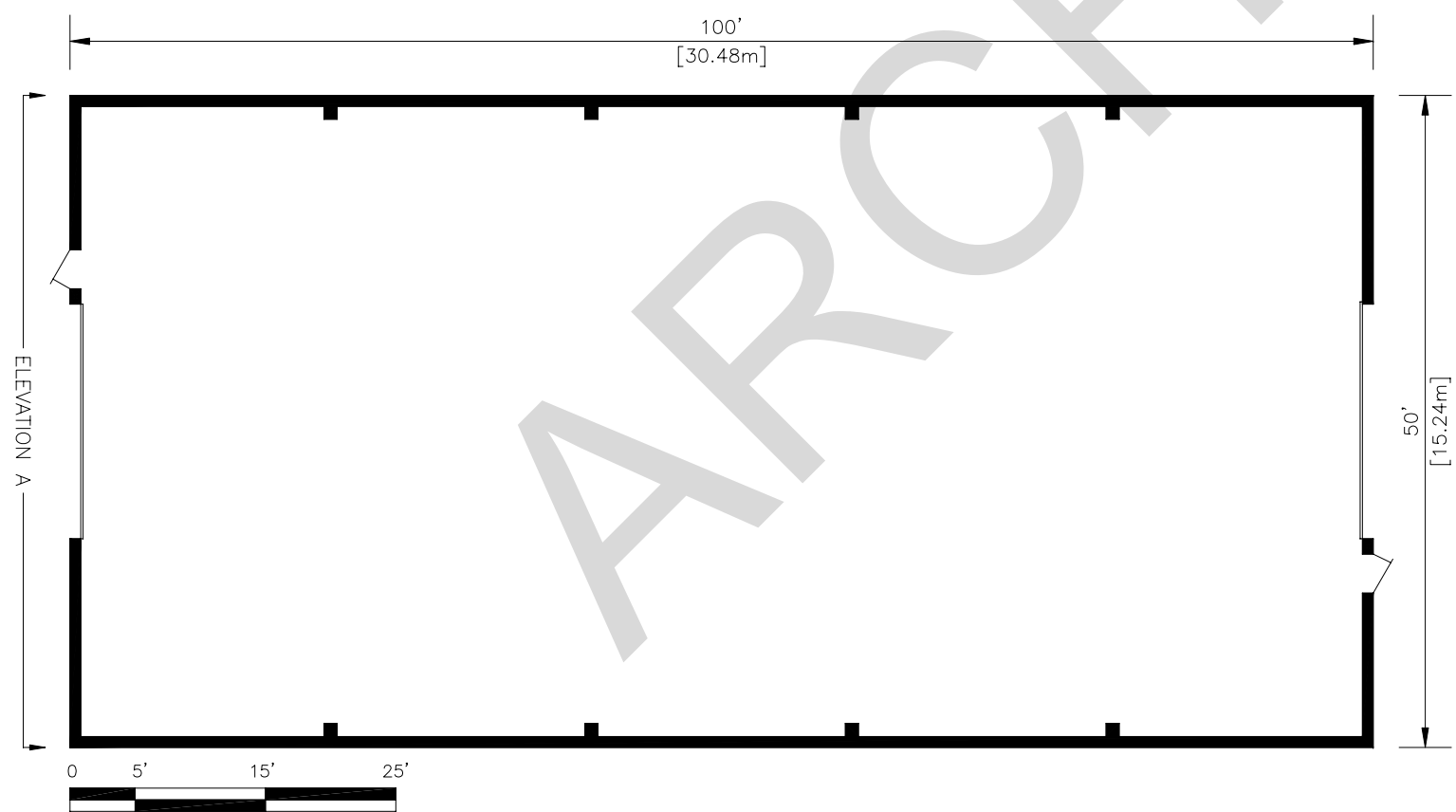

Facility Floor Plan

Category Code 422-265 Inert Spares Storage

- Design Related to Aircraft Type**
Aircraft Type: Fighter
Primary Aircraft: F-15

- Stand Alone Facility**
- Consolidated Facility**
- Other Uses:**

- Single Wing**
- Multiple Wings**

Structural	<ul style="list-style-type: none"> • Facility size dependent upon mission needs. Use the Unit Master Storage Plan to calculate floor space. • Design exterior apron/pavement and composition to accommodate weapon system and MMHE • Provide steel doors sufficient to accommodate size of assigned munitions weapon system(s)
Electrical	<ul style="list-style-type: none"> • Provide UL-approved interior lighting • May require electrical outlets
Fire/Safety	<ul style="list-style-type: none"> • Use non-combustible material per UFC 3-600-01 • Provide lightning and surge protection per NFPA 780, MIL HDBK 419, and AFMAN 91-20
Force Protection	<ul style="list-style-type: none"> • Provide high security hasps and intrusion detection system per AFI 31-101 • Install exterior security lighting based on local threat assessment
Equipment	<ul style="list-style-type: none"> • May require climate control dependent on munitions type and local climate

- Other References:**
- AFH 32-1084 – Facilities Requirements
 - AFMAN 91-201 – Explosives Safety Standards
 - AFI 31-101 – The Physical Security Program
 - DoD 6055.9 STD – DoD Ammunition and Explosives Safety Standards

ARCHIVED

Please see the next page.

4.3.7

Category Code 422-271

Module Barricaded Storage

This facility provides field storage for large quantities of explosives in unconstrained land areas. It is intended for use primarily in austere areas or other locations specifically approved under [AFMAN 91-201](#). Modular storage is only approved for certain munitions items such as high explosive bombs, similarly cased hazard class/division (HC/D) 1.1 munitions, 20 mm and 30 mm ammunition in metal shipping containers, and cluster bomb units (CBU) in authorized non-flammable shipping containers per [DoD 6055.9-STD](#) and [AFMAN 91-201](#). The maximum NEW permitted to be stored in each cell is 250,000 lbs (113,636 kg).

4.3.7.1 Facility-Specific Construction Requirements

1. The module is a series of connected cells with hard-surface storage pads separated from each other by barricades. Barricade walls are made of non-fragmenting materials (typically soil with no rocks/debris weighing more than 10 lbs (4.5 kg) or 6 in (152 mm) in diameter).
2. Pad may have non-combustible lightweight shed or roof covering.
3. Pad base may be concrete, asphalt, packed soil, or AM-2 matting.

4.3.7.2 Facility-Specific Spatial Requirements

The size of the module pads is determined by mission needs and available space (relative to meeting Q-D requirements). Refer to Unit Master Storage Plan, [DoD 6055.9-STD](#) and [AFMAN 91-201](#) for further guidance.

4.3.7.3 Facility-Specific Mechanical Requirements

Not applicable.

4.3.7.4 Facility-Specific Electrical Requirements

1. Must have a serviceable lightning protection system installed.
2. May require exterior lighting and grounding points, depending on weapons system stored.

4.3.7.5 Other Specific Requirements

Not applicable.



Please see the next page.

ARCHIVED



Location: Kadena AB, Japan
Command: PACAF
Facility Number: 42655
Date Constructed: 1977

Facility Overview

This facility provides a means of field storage for large quantities of explosives in areas where construction of earth-covered igloos is not feasible. Open storage of explosive munitions is considered to be a temporary storage alternative, not a preferred method.

Design

- Large unobstructed pads surrounded by berms
- Size is variable depending on mission requirements
- Overhead lightning protection system
- Overhead lighting for night operations
- May store as much as 250,000 lbs (113,398.1 kg) Net Explosives Weight if quantity distance requirements are met

Space Usage

Size (Total) 2,500 – 22,500 sq ft (232.26 – 2,090.32m²)



Retaining Wall



Pad with Containers

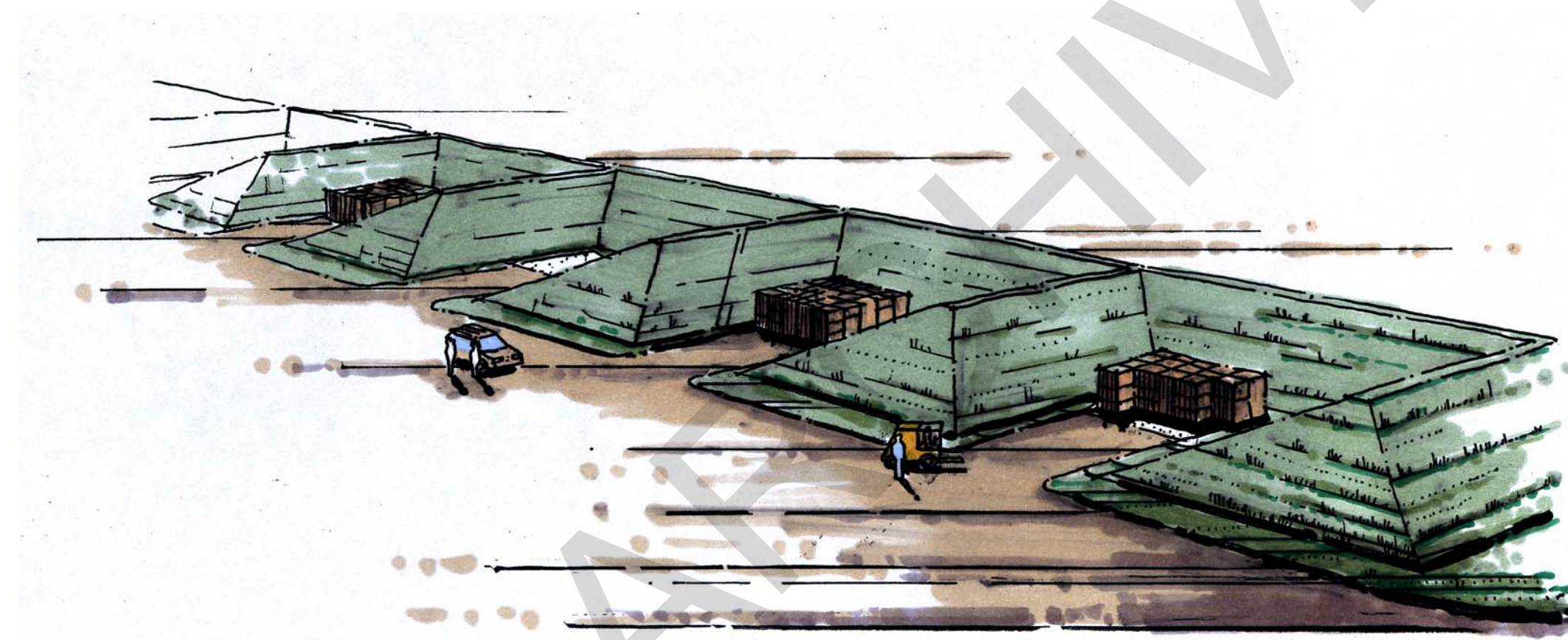

Facility Concept Drawing

Category Code 422-271

Module Barricaded Storage

- Design Related to Aircraft Type**
 Aircraft Type: Fighter
 Primary Aircraft: F-15

- Stand Alone Facility**
 Consolidated Facility
Other Uses:

- Single Wing**
 Multiple Wings

Structural	<ul style="list-style-type: none"> • Module barricade size dependent upon mission needs. Refer to AFMAN 91-201 and DoD 6055.9 STD. • Use asphalt, concrete, AM-2 matting, or packed soil to construct cell pavement/pad • Pad may have non-combustible lightweight shed or roof covering
Electrical	<ul style="list-style-type: none"> • May require exterior lighting
Fire/Safety	<ul style="list-style-type: none"> • Provide lightning protection per NFPA 780, MIL HDBK 419, and AFMAN 91-201
Force Protection	<ul style="list-style-type: none"> • Install exterior security lighting based on local threat assessment
Equipment	<ul style="list-style-type: none"> • No specific requirements noted

Other References:

- AFH 32-1084 – *Facilities Requirements*
- AFMAN 91-201 – *Explosives Safety Standards*
- AFI 31-101 – *The Physical Security Program*
- DoD 6055.9 STD – *DoD Ammunition and Explosives Safety Standards*

ARCHIVED

Please see the next page.

4.3.8 Category Code 422-275 Ancillary Explosives Facility



Figure 4.25
Ancillary Explosives Facility -
Munitions Loading/Unloading
Dock - Luke AFB, AZ

Facilities in this category code include rail classification yards, secure holding yards, inspection stations, interchange yards, loading docks, ready explosives facilities, and bomb preload stations to include the Munitions Assembly Conveyor (MAC). These facilities are defined in [AFH 32-1084](#). Flight line holding points are not included (listed as category code 422-277).

4.3.8.1 Facility-Specific Construction Requirements

1. Overhead cover may be required to protect personnel from the sun and other elements.
2. Fencing may be required based upon the security requirements outlined in [AFI 31-101](#).
3. Ground surfaces may require paving or other hardened surface (AM-2 matting, stone, etc.) as warranted by the traffic volume and gross weight of loaded munitions support equipment.
4. Barricades may be required based upon the location, hazard class, and NEW of explosives. Barricade walls are made of non-fragmenting materials (typically soil with no rocks or debris weighing more than 10 lbs (4.5 kg) or 6 in (152 mm) in diameter).
5. Sufficiently sized paved surfaces are required to meet traffic volume and turning radii of handling equipment and vehicles.



Figure 4.26
Ancillary Explosives Facility -
MAC Pad - Cannon AFB, NM

4.3.8.2 Facility-Specific Spatial Requirements

1. Installation explosives storage requirements are based on a unit's mission(s), support, training, weapon bed down plans, and operational plan requirements.
2. Storage requirements above current capabilities should be developed jointly with base safety and engineering offices.
3. Within rail classification, holding, and interchange yards, the length of the track is dependent upon volume of traffic at the base.
4. Rail tracks should be looped to permit two exit routes.



4.3.8.3 Facility-Specific Mechanical Requirements

May require HVAC for climate control in field offices supporting the assigned functions depending on local climate conditions.

4.3.8.4 Facility-Specific Electrical Requirements

1. Provide grounding, surge protection, and LPS.
2. Rails and related track material that is used in rail classification, holding, and interchange yards must be bonded, grounded, and insulated from the remaining track.
3. May require electrical outlets and interior/exterior lighting as described in [TM 5-811](#) and [AFMAN 91-201](#).
4. Secure holding area lighting must be automatically timed and positioned so as to not expose/silhouette guards. Lighting must extend 25 ft (7.6 m) beyond the perimeter of the holding area. [DoD 4500.9-R Regulation](#), *Defense Transportation Regulation (DTR) Part II* contains information on establishing a secure parking area.
5. Secure holding area must have a primary power source and an emergency backup power source that starts up when the primary fails.



Figure 4.27
Ancillary Explosives Facility -
Barksdale AFB, LA

4.3.8.5 Other Specific Requirements

1. Explosives safety criteria, Q-D, and storage compatibility groups must be considered for all items. Existing and proposed facilities must be able to store a NEW that meets mission requirements without violating Q-D criteria.

Q-D criteria does not apply to incoming vehicle and rail inspection stations used solely for inspections, or in interchange yards when the exchange is made and vehicles/railcars are promptly moved.
2. Rail trackage will be of standard gauge, clearance, and weight as required by interstate/host nation regulations. See [AFMAN 32-1125\(I\)](#), *Railroad Design and Rehabilitation* for additional guidance.
3. Rail trackage will connect with the common carrier delivering shipments to the base.
4. Vegetation control is strictly enforced along rail trackage per [AFMAN 91-201](#).
5. Secure holding area requires the following security items. [DoD 4500.9-R Regulation](#), *Defense Transportation Regulation (DTR) Part II* contains information on establishing a secure parking area.
 - a. Perimeter fencing



- b. Access control and a means (barriers) to stop unauthorized entry
 - c. Security-warning signs posted every 300 ft (91 m)
 - d. Duress system to notify security forces of unauthorized entry
 - e. Intrusion detection system or closed circuit television if the guard does not have direct visual observation of the area
6. Preload station (munitions assembly conveyor pad) requires legible on-site safety placarding as per [AFMAN 91-201](#).

ARCHIVED



Please see the next page.

ARCHIVED



Location: Barksdale AFB, Louisiana
Command: ACC
Facility Number: Vehicle Loading Dock
Date Constructed: 1951

Design

- Large apron around dock
- Overhead cover protects the dock
- Overhead cover has lighting and a lightning protection system

Facility Overview
 This facility is used to transfer explosives and inert material to commercial vehicles during munitions inbound and out-bound shipments. The facility is also used to support intra-area munitions movements by GOV.

Space Usage
 Size (Total) 2,100 sq ft (195.10m²)



Vehicle Loading Dock

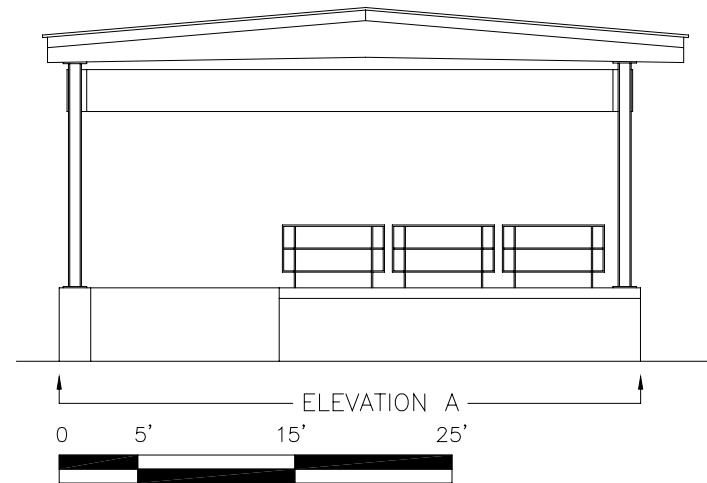

Facility Elevation

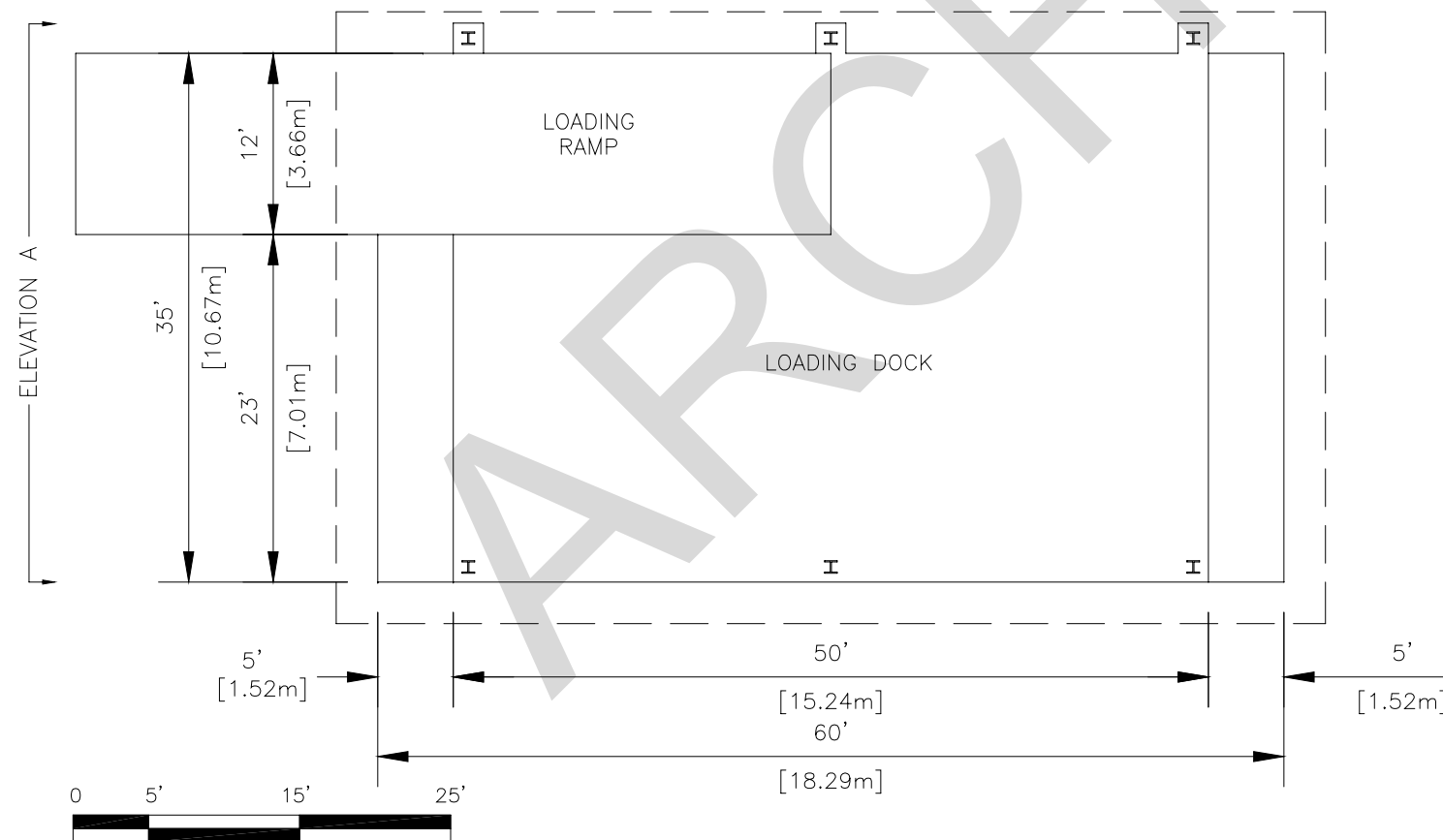

Facility Floor Plan

Category Code 422-275

Ancillary Explosives Facility

Design Related to Aircraft Type
 Aircraft Type: Bomber
 Primary Aircraft: B-52

Stand Alone Facility
 Consolidated Facility
Other Uses:

Single Wing
 Multiple Wings

Structural	<ul style="list-style-type: none"> • Pavements must be of sufficient composition to support munitions materiel and munitions Materiel handling equipment (MMHE) • Adequate access roads • Other structural component requirements will vary based on facility sub-category type, and may include: <ul style="list-style-type: none"> - Classification Yard - Holding Yard - Inspection Station - Interchange Yard - Loading Dock - Ready Explosives Facility - Bomb Preload Station
Electrical	<ul style="list-style-type: none"> • Electrical service to the area (if required) must be buried underground per AFMAN 91-201 • Provide explosive-proof lights per AFMAN 91-201 where explosive vapors are present • Provide UL-approved lighting fixtures in areas where explosive proof lighting is not required.
Fire/Safety	<ul style="list-style-type: none"> • Provide lightning and surge protection per NFPA 780, MIL HDBK 419, and AFMAN 91-201 • Provide grounding system per AFI 32-1065
Force Protection	<ul style="list-style-type: none"> • Install exterior security lighting based on local threat assessment • May require security fencing and gates
Equipment	<ul style="list-style-type: none"> • None

Other References:

- AFH 32-1084 – *Facilities Requirements*
- AFMAN 91-201 – *Explosives Safety Standards*
- AFI 31-101 – *The Physical Security Program*
- DoD 6055.9 STD – *DoD Ammunition and Explosives Safety Standards*

ARCHIVED

Please see the next page.

Location: Eglin AFB, Florida
Command: ACC (tenant)
Facility Number: Vehicle Holding Yard and Inspection Station
Date Constructed: 2001

Facility Overview
 This facility is used as a temporary holding point and inspection stations for in-bound and out-bound munitions shipments entering the base. The facility is located in a remote part of the base and has parking capability to accommodate up to four commercial tractor-trailer rigs.

Design

- Large area can accommodate up to four commercial tractor trailers
- Area is secured by fencing and gates
- Area has overhead lighting for night operations
- Hard-line telephone provides quick access to security forces and munitions personnel

Space Usage
 Size (Total) 27,000 sq ft (2,508.38m²)



Vehicle Turn-around



Overhead Lighting

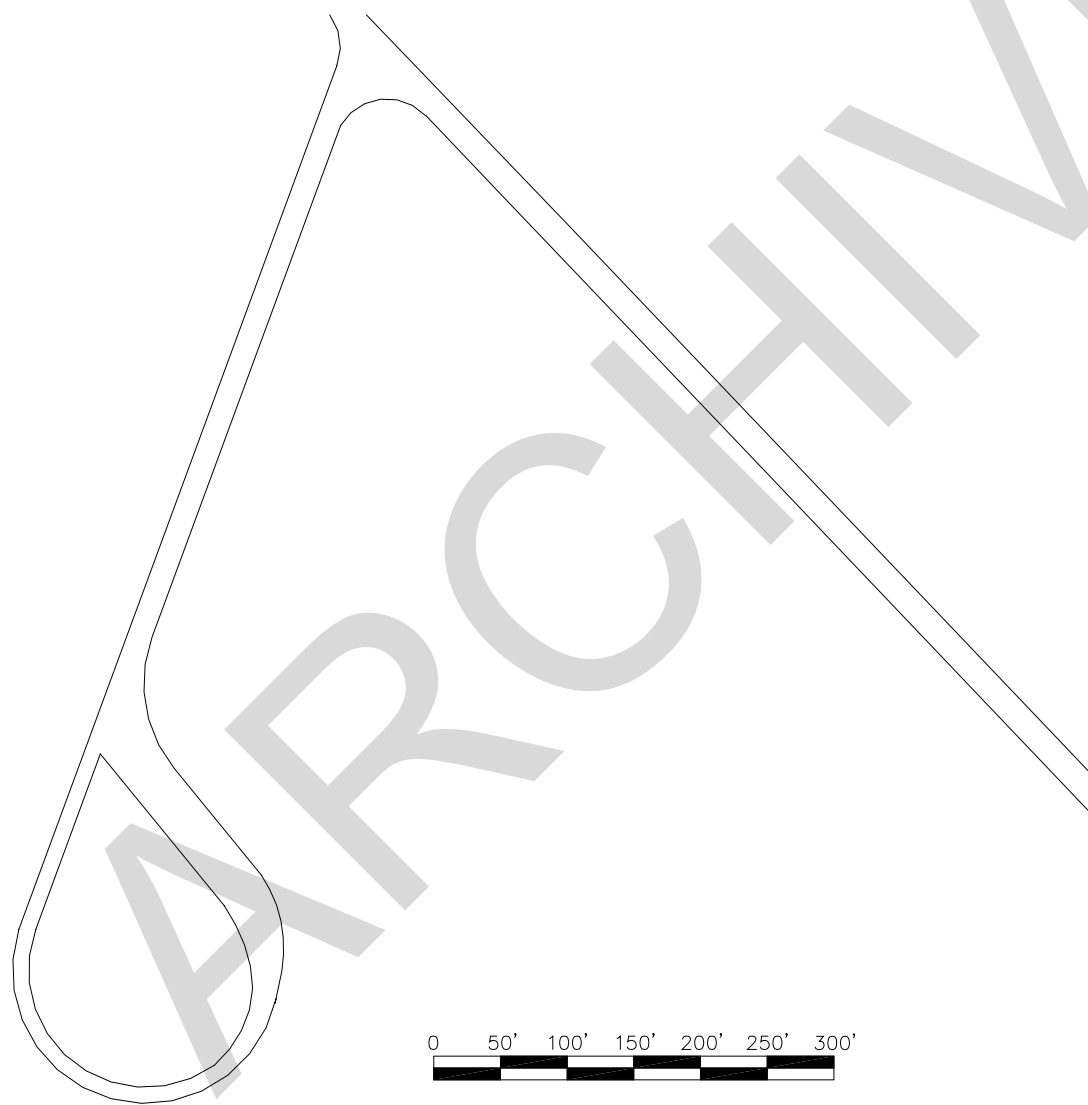

Facility Site Layout

Category Code 422-275

Ancillary Explosives Facility

Design Related to Aircraft Type
 Aircraft Type: Multiple
 Primary Aircraft: Multiple

Stand Alone Facility
 Consolidated Facility
 Other Uses:

Single Wing
 Multiple Wings

Structural	<ul style="list-style-type: none"> • Pavements must be of sufficient composition to support munitions material and munitions material handling equipment (MMHE) • Adequate access roads • Other structural component requirements will vary based on facility sub-category type. <ul style="list-style-type: none"> - Classification Yard - Holding Yard - Inspection Station - Interchange Yard - Loading Dock - Ready Explosives Facility - Bomb Preload Station
Electrical	<ul style="list-style-type: none"> • Electrical service to the area (if required) must be buried underground per AFMAN 91-201 • Provide UL-approved lighting in areas where explosives vapor or dust hazard are not present • Provide explosive-proof lights per AFMAN 91-201
Fire/Safety	<ul style="list-style-type: none"> • Provide lightning and surge protection per NFPA 780, MIL HDBK 419, and AFMAN 91-201 • Provide grounding system per AFI 32-1065
Force Protection	<ul style="list-style-type: none"> • Install exterior security lighting based on local threat assessment • May require security fencing and gates
Equipment	•None

Other References:

- AFH 32-1084 – *Facilities Requirements*
- AFMAN 91-201 – *Explosives Safety Standards*
- AFI 31-101 – *The Physical Security Program*
- DoD 6055.9 STD – *DoD Ammunition and Explosives Safety Standards*

ARCHIVED

Please see the next page.

Location: McChord AFB, Washington
Command: AMC
Facility Number: 825
Date Constructed: 1994

Facility Overview

This facility is designated as an authorized location to support fighter or bomber bomb build-up operations. The facility provides ample space to maneuver munitions support equipment and vehicles during bomb build-up operations.

Design

- Large area accommodates bomb buildup operations
- Surrounding apron facilitates maneuverability
- Close proximity to the flight line
- Overhead structure has power and compressed air outlets
- Area has overhead lighting for night operations

Space Usage

Size (Total) 20,540 sq ft (6,260.59m²)



Munitions Assembly Conveyor (MAC) Pad



Munitions Assembly Conveyor

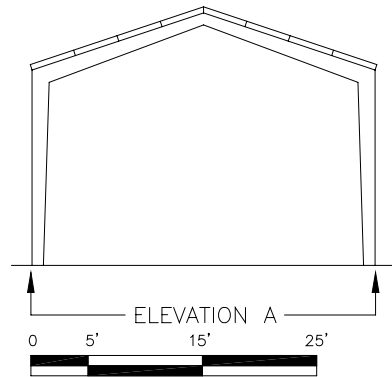

Facility Elevation

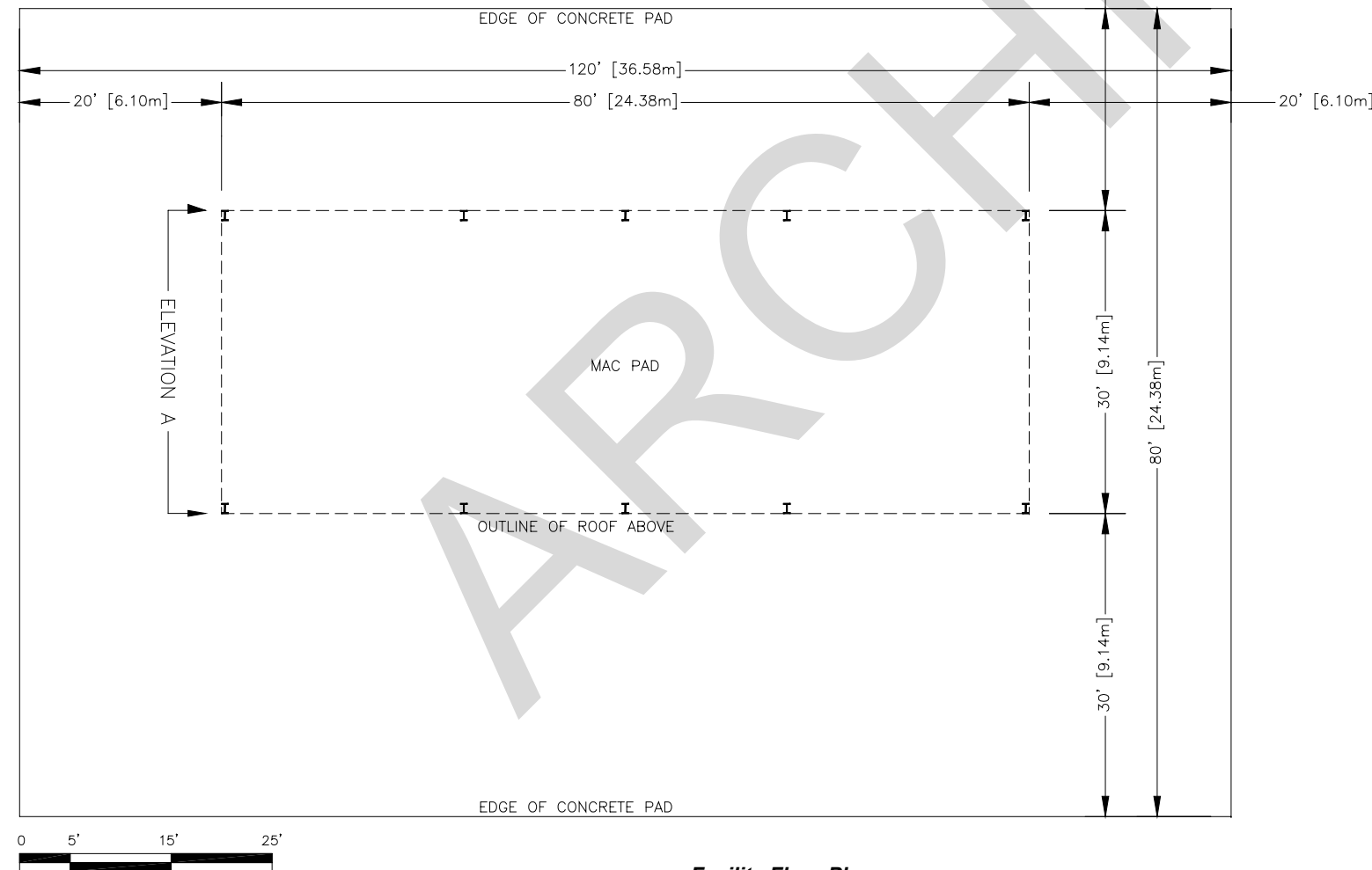

Facility Floor Plan

Category Code 422-275

Ancillary Explosives Facility

- Design Related to Aircraft Type**
 Aircraft Type: Multiple
 Primary Aircraft: Multiple

- Stand Alone Facility**
 Consolidated Facility
Other Uses:

- Single Wing**
 Multiple Wings

Structural	<ul style="list-style-type: none"> • Pavements must be of sufficient composition to support munitions material and munitions materiel handling equipment (MMHE) • Adequate access roads • Other structural component requirements will vary based on facility sub-category type. <ul style="list-style-type: none"> - Classification Yard - Holding Yard - Inspection Station - Interchange Yard - Loading Dock - Ready Explosives Facility - Bomb Pre-load Station
Electrical	<ul style="list-style-type: none"> • Electrical service to the area (if required) must be buried underground per AFMAN 91-201 • Provide UL-approved lighting in areas where explosive proof lighting is not required • Provide explosive-proof lights per AFMAN 91-201 where explosive vapors are present
Fire/Safety	<ul style="list-style-type: none"> • Provide lightning and surge protection per NFPA 780, MIL HDBK 419, and AFMAN 91-201 • Provide grounding system per AFI 32-1065
Force Protection	<ul style="list-style-type: none"> • Install exterior security lighting based on local threat assessment • May require security fencing and gates
Equipment	<ul style="list-style-type: none"> • None

Other References:

- AFH 32-1084 – *Facilities Requirements*
- AFMAN 91-201 – *Explosives Safety Standards*
- AFI 31-101 – *The Physical Security Program*
- DoD 6055.9 STD – *DoD Ammunition and Explosives Safety Standards*

ARCHIVED

Please see the next page.

Basic Design Standards for Munitions

Transportation Facilities

- [AFH 32-1084](#),
Facility Requirements
- [AFI 32-1021](#),
*Planning and
Programming
Military Construction
(MILCON) Projects*
- [AFMAN 91-201](#),
*Explosives Safety
Standards*
- [TM 5-1300/AFM 88-
22](#), *Structures to
Resist the Effects of
Accidental Explosives*
- [DoD 5100.76-M](#),
*Physical Security of
Sensitive
Conventional Arms,
Ammunition and
Explosives*
- [AFJMAN 32-8008,
Vol 1](#), *General
Provisions for
Airfield/Heliport
Pavement Design*
- [DoD 4500.9-R
Regulation](#), *Defense
Transportation
Regulation (DTR)
Part II*
- [UFC-3-260-01](#),
*Airfield and Heliport
Planning and Design.*
- [Mil HDBK 1013/1A](#),
*Design Guidelines for
Physical Security of
Facilities*
- [Technical Order](#)
(T.O.) 11A-1-61-4,
and pertinent
technical orders of the
11A, 11C, 11G, 11K,
11N, and 11P series.

4.4 Transportation Facilities

Transportation facilities provide for the movement of munitions materials and equipment to meet operating and mission requirements. These facilities include dangerous cargo pads, flight line munitions holding points, primary and alternate munitions movement routes, vehicle parking, and load and unload platforms (railheads).



Please see the next page.

ARCHIVED





Figure 4.28
Dangerous Cargo Pad -
McCord AFB, WA

4.4.1 Category Code 116-662 Pad, Dangerous Cargo

Dangerous cargo pads are paved areas for loading and unloading explosives and other hazardous cargo from aircraft. They are required at facilities where Q-D safety criteria would be violated (in relation to other critical resources) if the existing aprons were used for loading and unloading explosives or dangerous cargo. Do not site explosives or activities involving explosives within the Landing Lane Clear Zone and Accident Potential Zone. For further details, see [UFC 3-260-01](#), *Airfield and Heliport Planning and Design*, [AFI 32-7063](#), *Air Installation Compatibility Use Zone Program*, and [AFH 32-7084](#), *AICUZ Program Manager's Guide*.

Paved shoulders are provided around the perimeter of an apron to protect adjacent areas from jet blast, help mitigate foreign object damage (FOD), provide structural support for blast deflectors, permit equipment storage, and to facilitate drainage. Criteria for apron shoulders are presented in [UFC 3-260-01](#) for fixed-wing aircraft, and [AFH 32-1084](#) for rotary-wing aircraft. The surface adjacent to the paved shoulder should be graded to facilitate drainage and to prevent storm water from ponding on the outside edge of the shoulder.

4.4.1.1 Facility-Specific Construction Requirements

1. Access road surfaces should be constructed of concrete.
2. An access taxiway connecting the pad to a taxiway is required. Medium-load pavement designed to accommodate airlift aircraft should be installed for the pad and access taxiway.
3. Provide a revetment when required by Q-D criteria.
4. Provide a means to post applicable explosives safety fire/hazard symbols.



Figure 4.29
Dangerous Cargo Pad -
Langley AFB, VA

4.4.1.2 Facility-Specific Spatial Requirements

A paved roadway to the hazardous cargo pad for access by trucks and other vehicles should be provided.

1. The location of the pad must comply with the criteria outlined in [UFC 3-260-01](#), [DoD 6055.9-STD](#), and [AFMAN 91-201](#). The effects of jet blast turbulence and temperature should be considered during the siting and design processes.
2. A circular pad with a 110 ft (33.5 m) radius and 4,225 sq yd (3,530 m²) is authorized for installations other than Aerial Ports of Embarkation/Debarcation (APOE/APOD).
3. APOE/APODs that store or process in-transit explosives require two pads to accommodate C-141, C-5, C-17, and Boeing 747



aircraft. Additional pads are required where there is an unusually high volume of activity. Design details are:

- a. A semicircular pad is needed by large cargo aircraft up to and including the dimensions of the C-5.
 - b. The space requirement for each pad is about 8,900 sq yd (7,440 m²). The siting and configuration of the pads is based on 30,000 lb (13,600 kg) of NEW HC/D 1.1.
4. Hazardous cargo pads may be larger than these dimensions if the design aircraft cannot maneuver on the pad. Sources for obtaining information concerning minimum turning radii for various aircraft is presented in Army [ETL 1110-3-394](#), *Aircraft Characteristics for Airfield-Heliport Design and Evaluation*.
 5. Paved shoulders should be a minimum 10 ft (3.1 m) wide with lights installed. Wider shoulders are required for wide-bodied aircraft. Shoulders provide locations for lighting and control of FOD.
 6. Aprons should be sized to allow safe movement of aircraft under their own power and must provide sufficient space for parking fixed- and rotary-wing aircraft.

4.4.1.3 Facility-Specific Mechanical Requirements

Storm water runoff collection system including inlets, trench drains, manholes, and pipe should be provided. This system shall direct flows to a collection system to ensure flows do not impact airfield operations.

4.4.1.4 Facility-Specific Electrical Requirements

1. Telephone service, apron lighting, and airfield lighting are required for safety.
2. Apron edge lighting and airfield lighting must be blue, flush type taxiway lights around the edge of the pads in accordance with [AFI 32-1044](#), *Visual Air Navigation Systems* and [AFMAN 32-1076](#), *Design Standards for Visual Air Navigation Facilities*.
3. Grounding points must be provided on each hazardous cargo pad for aircraft and munitions materiel handling equipment (MMHE) grounding. These points are detailed in [UFC 3-260-01](#).

4.4.1.5 Other Special Requirements

1. Tie-down/mooring points/tie-down mooring eyes must be provided on each hazardous cargo pad. These points are detailed in [UFC 3-260-01](#).
2. Water/hydrants for firefighting will be included to serve the pad(s).



Location: Hill AFB, Utah
Command: AFMC
Facility Number: Pad 3
Date Constructed: 1964/2004

Facility Overview

Hazardous cargo pads are paved areas for loading and unloading explosives and other hazardous cargo from aircraft. Hazardous cargo pads are required at facilities where the existing aprons cannot be used for loading and unloading hazardous cargo. Pad 3 at Hill AFB is used for both loading and unloading munitions onto cargo aircraft, loading munitions onto combat aircraft, and as a parking area for loaded combat aircraft.

Design

- Sited for 30,000 lbs (13,608 kg) Net Explosives Weight (NEW)
- Large area allows for two simultaneous operations
- Excellent access to taxiways and munitions delivery routes
- Adequate maneuvering room for large vehicles
- Well marked with signage and directional markings

Space Usage

Size (Total) 146,665 sq ft (13,625.63m²)



Revetment and Lighting



Signage

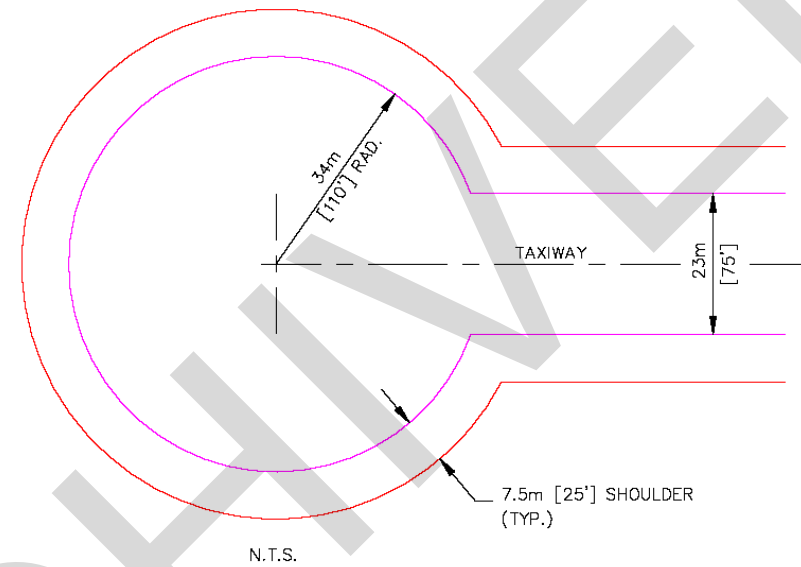

Circular Pad for Small Aircraft

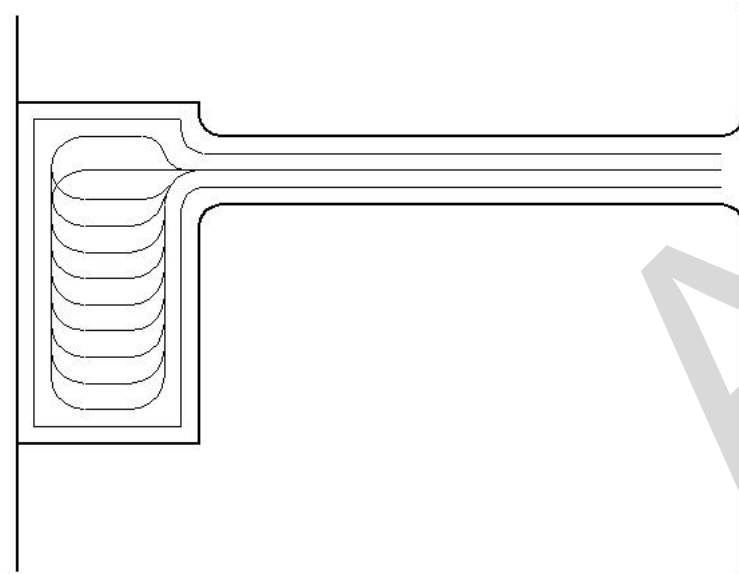

Plan View, Dangerous Cargo Pad at Hill AFB

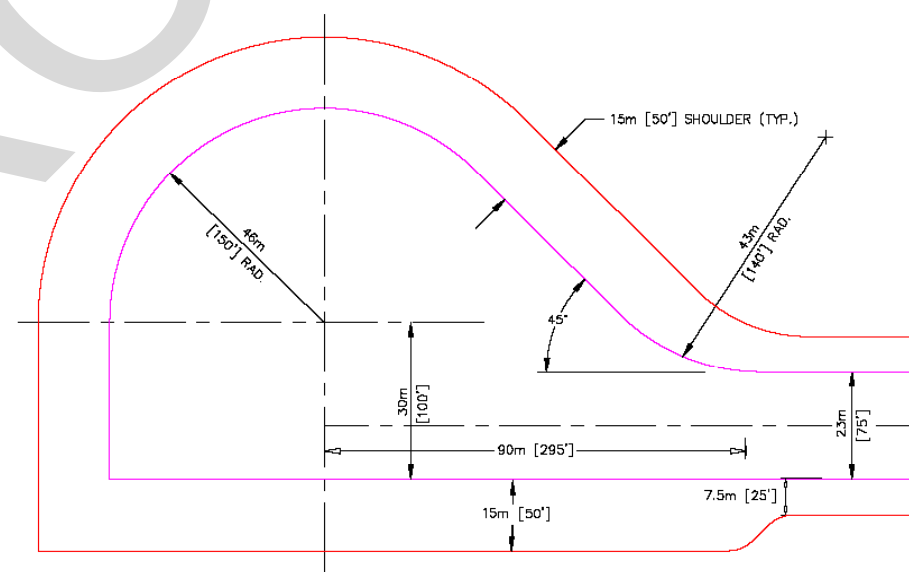

Semi-Circular Pad for large cargo aircraft and APOEs and APODs

Category Code 116-662
Pad, Dangerous Cargo

- Design Related to Aircraft Type**
 Aircraft Type: Cargo and Combat
 Primary Aircraft: C-5, C-17, F-16
- Stand Alone Facility**
- Consolidated Facility**
 Other Uses: Combat Aircraft Loading and Parking

- Single Wing**
- Multiple Wings**

Structural

- Locate pad per AFMAN 91-201, DoD 6055.9 STD, and UFC 3-260-01
- Pad size approximately 8,900 sq yd (7,441.20m²)
- Turning radii per ETL 1110-3-394
- For small cargo aircraft, the hazardous cargo pad is a circular pad.
- For APOE/APODs the hazardous cargo pad is a semi-circular pad.
- If APOE/APOD handles explosives, two pads authorized; 8,900 sq yd (7,441.20m²) each
- Medium load pavement (pad and access taxiway)
- Provide minimum 10 ft (3.00m) wide paved shoulders
- Between 25 ft (7.62m) and 50 ft (15.24m) wide paved shoulders for C-5, E-4, and Boeing 747 aircraft
- Provide revetment if required by explosives safety criteria
- Concrete access road

Electrical

- Install blue, flush-type taxiway lights in shoulder per AFI 32-1044 and AFMAN 32-1076
- Provide telephone service

Fire/Safety

- Site pad for up to 30,000 lbs (13,608 kg) NEW, 1.1 at APOE/APOD locations per AFMAN 91-201
- Provide aircraft and equipment grounding per AFI 32-1065, AFMAN 91-201, and UFC 3-260-01
- Provide aircraft tie-downs per UFC 3-260-01

Force Protection

- Install exterior security lighting based on local threat assessment

Equipment

- None

- Other References:**
- AFH 32-1084 – Facilities Requirements
 - AFMAN 91-201 – Explosives Safety Standards
 - AFI 31-101 – The Physical Security Program
 - DoD 6055.9 STD – DoD Ammunition and Explosives Safety Standards
 - UFC 3-260-01 – Airfield and Heliport Planning and Design

ARCHIVED

Please see the next page.



Figure 4.30
Munitions Holding Point -
Luke AFB, AZ

4.4.2 Category Code 422-277 Munitions Holding Point

The procedures for delivering munitions from the MSA to the aircraft vary based upon local and mission requirements. One option is direct delivery from the MSA to the flight line. The other option that can be selected by the Equipment Maintenance or Munitions Squadron Commander is to use a two-stage delivery process where a minimum amount of assembled munitions (usually one day's requirement) are temporarily moved to a flight line munitions holding point (also known as a holding area munitions (HAMS) yard) for delivery to the operational aircraft or subsequent return to the MSA.

4.4.2.1 Facility-Specific Construction Requirements

1. Provide paved roadways to the holding point gates for access of munitions handling equipment. Pavement used for access drives and aprons shall support the weight of munitions handling equipment and will not contribute to foreign object damage on the flight line. May be made of concrete, asphalt, or AM-2 matting.
2. The entire holding point shall be fenced and meet security requirements in **AFI 31-101**. Install an electrical motor-driven main vehicle access gate that is remotely controlled from the personnel shelter. Install a second, manually operated, vehicle access gate to provide drive-through capability.
3. The personnel shelter must have a bay window overlooking the holding pad and main entry gate.
4. Provide a revetment when required by Q-D criteria.



Figure 4.31
Munitions Holding Point -
McChord AFB, WA

4.4.2.2 Facility-Specific Spatial Requirements

1. The types and quantities of munitions, along with maneuvering room for munitions handling support equipment, dictate the space requirement for the holding point.
2. The number of personnel assigned determines the size of the personnel shelter. A common size is 250 sq ft (23 m²).
3. The location of the pad must comply with the criteria outlined in [UFC 3-260-01](#), [DoD 6055.9-STD](#), and [AFMAN 91-201](#). The effects of jet blast turbulence and temperature should be considered during the siting and design processes.



4.4.2.3 Facility-Specific Mechanical Requirements

Chapter 3, “General Design Guidance” contains basic criteria for the personnel shelter mechanical requirements (as dictated by climatic conditions).

4.4.2.4 Facility-Specific Electrical Requirements

1. Provide illumination on the holding point pad for night operations, as required.
2. Lightning protection will be installed per [NFPA 780](#), [DoD 6055.9-STD](#), and [AFMAN 91-201](#) unless the lightning protection system interferes with safety-of-flight operations.
3. Grounding points must be provided in sufficient quantities for units using ammunition-loading systems. Install grounding systems as per [AFI 32-1065](#).
4. Use [AFMAN 91-201](#) to determine the required separation of electrical utilities (e.g., lines, transformers) from the holding point based upon the amount of voltage and whether the utilities are above ground or below ground.
5. Use Chapter 3, “General Design Guidance” for the personnel shelter electrical requirements.

4.4.2.5 Other Specific Requirements

Provide a means to mount first aid fire extinguishers in the holding point area.



Location: Whiteman AFB, Missouri
Command: ACC
Facility Number: 4078
Date Constructed: 2002

Facility Overview

This facility is designed to hold limited quantities of assembled munitions for immediate delivery to the flight line. The facility is surrounded by a security fence that has two points of entry controlled by electronic gates.

Design

- Large area accommodates multiple munitions trailers and handling equipment
- Partial overhead cover
- Secured by fencing
- Protected by a lightning protection system

Space Usage

Size (Total) 64,320 sq ft (5,975.52m²)



Flight Line Munitions Holding Pad



Lightning Protection System

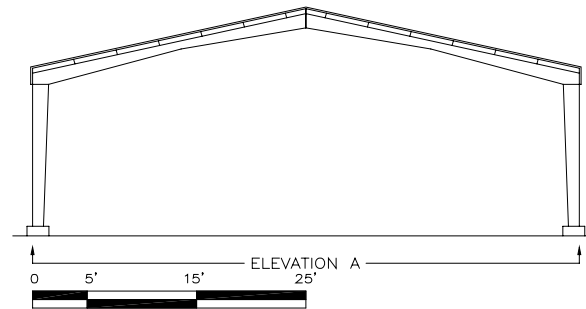

Facility Elevation

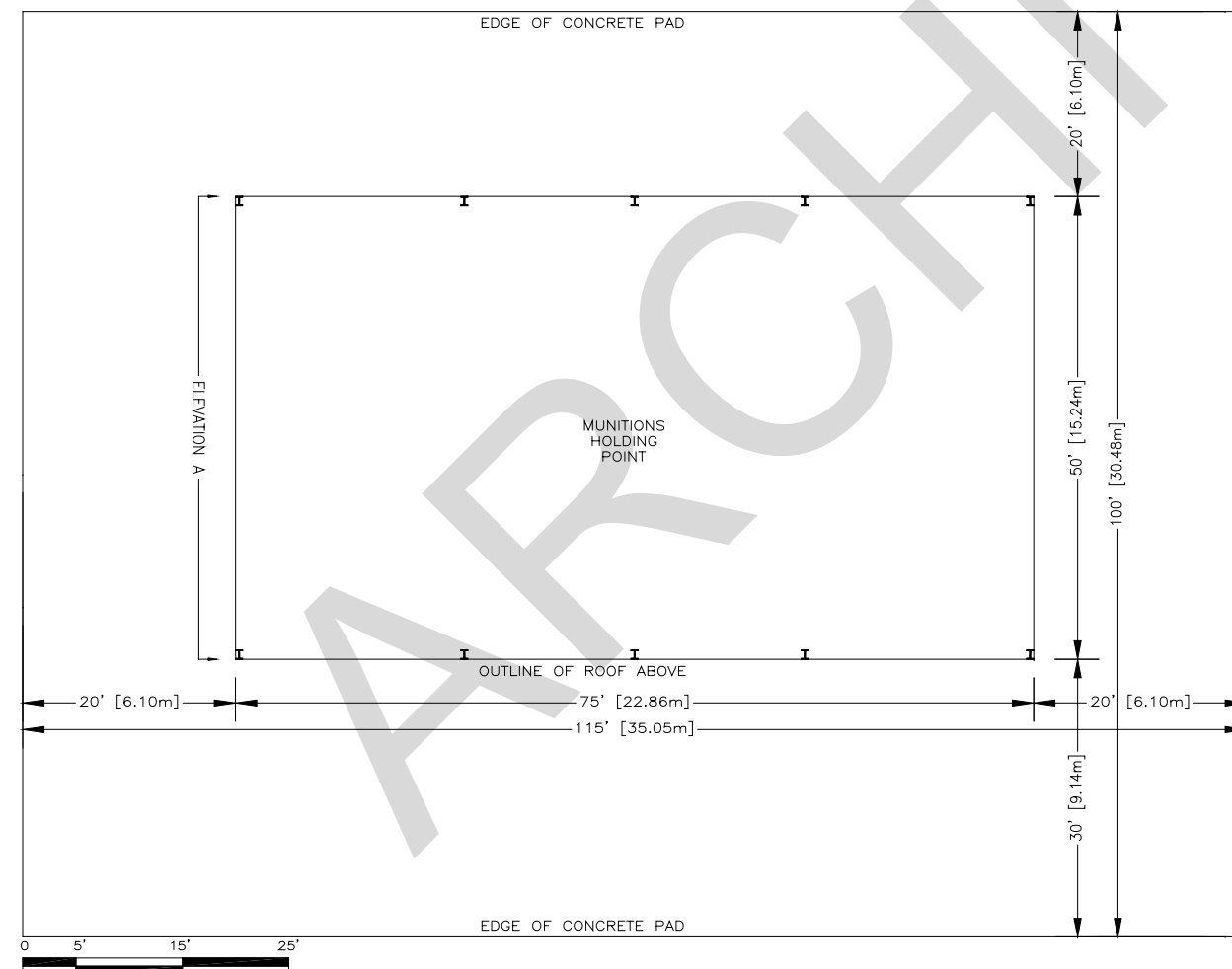

Facility Floor Plan

Category Code 422-277

Flight Line Munitions Holding Point

- Design Related to Aircraft Type**
 Aircraft Type: Bomber
 Primary Aircraft: B-2

- Stand Alone Facility**
 Consolidated Facility
Other Uses:

- Single Wing**
 Multiple Wings

Structural	<ul style="list-style-type: none"> • Pad size, composition, and load strength sufficient to accommodate the unit's daily munitions requirements, and allow for safe movement of MMHE • Provide personnel shelter latrine (portable or permanent) facilities • Provide fencing around pad • If shelter is provided, orient window so that it overlooks entire fenced area and entrance
Electrical	<ul style="list-style-type: none"> • Provide exterior lighting (as required) to permit night operations • If lighting required, provide a minimum 5 foot-candles interior lighting
Fire/Safety	<ul style="list-style-type: none"> • Provide lightning and surge protection per NFPA 780, MIL HDBK 419, and AFMAN 91-201, may not be required if it interferes with flight operations • Provide grounding system per AFI 32-1065 • Use non-combustible material per UFC 3-600-1 • Electrical utilities have required separation from the holding area. Distances are dependent upon amount of voltage the lines carry and functions the lines support
Force Protection	<ul style="list-style-type: none"> • Install exterior security lighting based on local threat assessment
Equipment	<ul style="list-style-type: none"> • Personnel shelter may require HVAC depending on local climate • Flight line holding point gate(s); primary gate - electrical, motor-driven, remotely controlled drive-through. Secondary gate - manually operated drive-through.

Other References:

- AFH 32-1084 – Facilities Requirements
- AFMAN 91-201 – Explosives Safety Standards
- AFI 31-101 – The Physical Security Program
- DoD 6055.9 STD – DoD Ammunition and Explosives Safety Standards

ARCHIVED

Please see the next page.

4.4.3 Category Code 851-147 Explosives Movement Routes



Figure 4.32
Explosives Movement Route -
Langley AFB, VA

These are primary and alternate routes used to transport explosives from one location on an installation to another. Although design criteria for Real Property Category Group 85 is generally applicable to all roads and streets on the installation, the primary purpose of this section is to assist in the selection and location of explosives movement routes.

Vehicle traffic volume, range of vehicular loads (weight), and mix of vehicles determines the dimensional requirements for roads. Additional information on road requirements can be found in [AFH 32-1084](#) and in [AFMAN 91-201](#). Curbs and gutters will not be provided in isolated areas (such as MSA, bulk fuel storage areas) or open storage and other facilities far removed from the main part of the base (unless required for stormwater control).



Figure 4.33
Explosives Movement
Route -
Barksdale AFB, LA

The safest primary and alternate explosives movement routes should be designated to cover each delivery route (delivery to MSA, delivery from MSA, delivery from MSA to flight line, etc.). The Base General Plan may aid in identifying these routes and explain any limitations on explosives quantities by HC/D. Routes near mission-oriented facilities, in areas that are densely populated, experience high-traffic volumes, or that pass through areas where schools, child development centers, youth centers, hospitals, recreational, or commercial areas are located, should be avoided. The routes should be confined to secondary roads where possible so that in the event of a mishap, the surrounding area may be evacuated. Roads should be of adequate geometry (e.g., turning radius) and structured to accommodate the MMHE and related explosives support vehicles. Roads and streets should also be able to support the typical loaded MMHE and vehicle weights associated with explosives movements.

The movement of munitions within a MSA to and from sited storage locations, and transportation of explosives in support of training working dogs is not restricted to designated routes per [AFMAN 91-201](#). Q-D criteria does not apply to munitions and explosives while being transported; however, precautions should be taken to ensure minimum exposure of people and property during all phases of transportation. The amount of time munitions and explosives are in the transportation mode must be limited to the minimum amount necessary to complete the task.

The transfer of explosives and munitions from storage areas to and from arm/disarm pads should occur on dedicated transfer roads. Where possible, transfer roads should be used exclusively for explosives and munitions transfer vehicles per [UFC 3-260-01](#).



Please see the next page.

ARCHIVED



4.4.4 Category Code 852-261 Vehicle Parking



Figure 4.34
Government Vehicle and
Equipment Parking -
Langley AFB, VA

This Cat Code applies to parking for government owned vehicles (GOV). For cold weather climates, Vehicle Operations Heated Parking (Category Code 214-426), IAW [AFH 32-1084](#) may be authorized.

Vehicular parking areas for munitions facilities are generally located adjacent to an activity whose function requires 24-hour access to a substantial number of its assigned vehicles. These areas are known as “subpools.” Authorization for subpool areas must be obtained from the transportation office and may include any parking space not identified by other real property category codes

Munitions GOV subpools require a paved or stabilized surface. Subpools may require floodlighting, a security fence at least 6 ft (1.8 m) high, and one or more controlled paved entrances when the operation presents a special need for safeguarding and night lighting.

Guidance for authorized vehicle operations subpools should follow [AFH 32-1084](#). Refer to Table 4.1, “Parking Space Requirements for Vehicle Operations Parking,” for additional vehicle parking space requirements.



Figure 4.35
Vehicle Parking -
Barksdale AFB, LA

4.4.4.1 Facility-Specific Construction Requirements

1. A paved or stabilized surface (e.g., concrete, asphalt, AM-2 matting, or packed stone, etc.) is required.
2. GOV and powered munitions trailer-parking areas should be located at least 100 ft (30 m) or intraline separation distance from explosives locations, unlike other motor pools which require inhabited building separation distances. The installation’s fire marshal and WSM may reduce these parking requirements for licensed explosives locations.

4.4.4.2 Facility-Specific Spatial Requirements

1. For additional GOV parking space guidance, refer to Aircraft Support Equipment Storage Yard (Category Code 852-273) and Non-Organizational Vehicle Parking (Category Code 852-262) in [AFH 32-1084](#).
2. Table 4.1 in this guide provides specific requirements to calculate the areas authorized for vehicle operations subpool parking. However, Table 4.1 does not take into account oversized and outsized vehicles and may require adjustments to meet circumstances at individual locations.



4.4.4.3 Facility-Specific Electrical Requirements

1. Areas may require floodlighting for security reasons or to meet the operational mission.
2. Provide exterior type electrical outlets at installations having severe winters to power vehicle engine heating devices.



Figure 4.36
Government Vehicle and
Equipment Parking -
Luke AFB, AZ

4.4.4.4 Other Specific Requirements

1. Vehicle parking areas should be well-drained to avoid standing water.
2. Areas should be enclosed with a 6 ft (1.8 m) fence, if not already cantoned.

Vehicle Space Factors	Gross Area	
	m ²	sq yd
50-100	3,180	3,800
101-150	4,870	5,825
151-250	8,110	9,700
251-350	11,400	13,600
351-450	14,600	17,500
451-650	21,100	25,250
651-850	27,200	32,500
851-1000	34,700	41,500

Table 4.1
Parking Space Requirements for Vehicle Operations Parking
(Source: [AFH 32-1084](#))



4.4.5 Category Code 890-158 Load and Unload Platform (Railhead)

Railroad trackage includes sidings, spurs, and tracks. Railroad construction should comply with guidelines found in [AFJMAN 32-1048](#), *Railroad Track Standards* and [AFMAN 32-1125\(I\)](#), *Railroad Design and Rehabilitation*. Guidelines for trackage are found in [AFH 32-1084](#). Construction of new rail facilities, or designation of existing rail facilities for the purpose of munitions movements, inspection, or holding must comply with the explosives safety guidelines found in [AFMAN 91-201](#). For information on railway construction and maintenance, refer to [American Railway Engineering and Maintenance-of-Way Association \(AREMA\)](#).

4.4.5.1 Facility-Specific Construction Requirements

- 1 Provide paved or stabilized surface (e.g., concrete, asphalt, AM-2 matting, or packed stone, etc.) for use by MMHE and other munitions support vehicles.
- 2 Access road, if required, should be constructed to accommodate the weight and turning radii of MMHE.
- 3 Railhead must have a loading ramp constructed of sufficient size to accommodate MMHE and rolling stock.

4.4.5.2 Facility-Specific Spatial Requirements

Land area for rail yards should be sufficient in size to ensure explosives-loaded vehicles/railcars are separated from each other by the applicable (based on NEW and type) above ground magazine distance. If the above ground magazine distance between vehicles/railcars cannot be met, vehicles/railcars should be parked in groups, with the above ground magazine separation between each group. Separation distances to other exposures (facilities or uses) should then be based on the total amount of explosives within a group of vehicles/railcars.

4.4.5.3 Facility-Specific Mechanical Requirements

If authorized, a stand-alone weather shelter not to exceed 250 sf (16 m²) will be provided for protection from the elements. Provide potable water, bathroom, sanitary sewer, and HVAC systems for the shelter.

4.4.5.4 Facility-Specific Electrical Requirements

1. Provide electrical system to support weather shelter.
2. Rails and related track material must be bonded, grounded, and insulated from the other railroad track on base.
3. Provide LPS.



4. As applicable, provide adequate lighting to meet local operational and security requirements.

4.4.5.5 Other Specific Requirements

1. Rail trackage will be of standard gauge, clearance, and weight as required by interstate/host nation regulations. See [AFMAN 32-1125\(D\)](#) for additional guidance.
2. If not within the confines of a controlled area (i.e., within the MSA), provide an enclosed area with a 6 ft (1.83 m) fence and control entry gate(s) to meet base security requirements.
3. Trackage layout should be looped to allow two ways of exit.
4. Intraline Q-D separation applies to all transfer operations involving explosives except for roll-on/roll-off operations (not involving lifting) and off-installation military van/International Organization for Standardization (MILVAN/ISO) container inter-/intra-modal transfers, including Trailer on Flat Cars (TOFC). This applies if containers are not stored or other operations are performed. Q-D separation is not required for these operations. The base WSM will determine the specific rules for safety distances for these types of operations.
5. Railheads for explosives-laden railcars should be located away from hazardous areas such as other explosives sites, Petroleum Oil Lubrication (POL) sites, populated areas, and flight lines. The area should be cantoned, with adequate Q-D standoff distances from public thoroughfares or boundary fences.



**Basic Design Standards
for Munitions
Administration Facilities**

- * [AFH 32-1084](#),
Facility Requirements
- * [AFI 32-1021](#),
*Planning and
Programming
Military Construction
(MILCON) Projects*
- * [AFMAN 91-201](#),
*Explosives Safety
Standards*
- * [TM 5-1300/AFM 88-
22](#), *Structures to
Resist the Effects of
Accidental Explosives*
- * [DoD 5100.76-M](#),
*Physical Security of
Sensitive
Conventional Arms,
Ammunition and
Explosives*
- * [DoD 6055.9-STD](#),
*Ammunition and
Explosives Safety
Standard*
- * [Mil HDBK 1013/1A](#),
*Design Guidelines for
Physical Security of
Facilities*
- * [AFI 21-201](#),
*Management and
Maintenance of
Non-Nuclear
Munitions*
- * [AFI 31-101](#), *The
Air Force
Installation Security
Program (FOUO)*

4.5 Munitions Administration Facilities

Administration facilities provide for the administrative affairs of the munitions community. For the purpose of this standard, administration facilities also house Line Delivery and Storage dispatch functions. The type of construction for administration facilities varies depending on local architectural standards. When siting the munitions administration facility, proximity to the primary work locations within the MSA should be considered to enhance productivity. Consult the Base Architectural Design Guide for additional guidance.



Please see the next page.

ARCHIVED





Figure 4.37
Munitions Administration
Facility - Luke AFB, AZ

4.5.1 Category Code 610-144 Munitions Administration Facility

These facilities house several functions including munitions operations, Combat Ammunition System (CAS), Munitions Control, flight/squadron leadership, dispatch, training, etc.

4.5.1.1 Facility-Specific Construction Requirements

1. Threat analysis may dictate using semi-hardened, splinter-protected, or hardened construction criteria.
2. Facilities housing the Munitions Control function must meet the following requirements:
 - a. Controlled area construction criteria outlined in **AFI 31-101**.
 - b. Solid wood or metal door with a mechanical or electrical lock and peephole or video monitoring device.
 - c. Floors covered with industrial grade carpeting, floor able to support the weight of safes.
 - d. Room completely enclosed as required in [AFI 21-201](#), *Management and Maintenance of Non-Nuclear Munitions*.

4.5.1.2 Facility-Specific Spatial Requirements



Figure 4.38
Munitions Administration
Facility - Cannon AFB, NM

1. Use the Unit Personnel Management Roster to help determine the number of personnel to be located in the facility. Using guidance provided in [AFH 32-1084](#), facility planners and designers should consider the types and numbers of building occupants and design for the types of activities within the facility.
2. The building gross floor area should not exceed 162 sf (15 m²) per person, plus authorized special purpose space. Refer to Table 4.2, “Munitions Squadron Administration Building” and Table 4.3, “Munitions Flight Administration Building Area Allocations” of this standard for size information on the average facility. Room sizes should be adjusted based on mission requirements.
3. A training area must be provided to support the Combat Munitions Training Program. Size of the classroom is based upon student throughput and space required for training aids.

4.5.1.3 Facility-Specific Mechanical Requirements

The facility shall be air-conditioned. HVAC requirements will be as prescribed by the applicable industry standard. HVAC requirements for



administrative areas must comply with requirements defined in Chapter 3, “General Design Guidance.”

4.5.1.4 Facility-Specific Electrical Requirements

- 1 A non-interruptible power supply is necessary to maintain operational capability.
- 2 Munitions Control requires sufficient 110 VAC power outlets to support radio base stations, status boards, computer systems, battery chargers, and other equipment as described in [TM 5-811](#) and [AFMAN 91-201](#). Munitions Control also needs standby and emergency power.
- 3 An LPS and surge protection is required.



Figure 4.39
Munitions Administration
Facility - McChord AFB, WA

4.5.1.5 Other Specific Requirements

Munitions Control requires: secure voice communications capability; two dedicated land mobile radio networks; dedicated phone lines to Explosives Ordnance Disposal, Fire Department, Security Forces, Command Post, Maintenance Operations Center, and all munitions work centers; and a local area network to operate Munitions Control 2000.

Functions	Net Area	
	sq ft	m ²
Squadron Commander	200	19
Commander's Secretary	120	11
First Sergeant	120	11
Section Commander	150	14
Orderly Room (6 people)	720	66
Safety/Quality Assurance (4 people)	480	44
Vehicle Control Officer	120	11
Resource Advisor	120	11
Maintenance Supervisor	150	14
Maintenance Superintendent	120	11
Subtotal	2,300	212
Circulation and Walls (15%)	272	25
Gross Total (MUNS Squadron Administration)	2,572	237
<i>Note: The Munitions Control and training functions may reside in the squadron administrative building.</i>		

Table 4.2
Munitions Squadron Administration Building (See Note)



Functions	Net Area	
	sq ft	m ²
Flight Commander, Flight Supervisor, or Munitions Accountable Systems Officer (MASO)	150	14
Superintendent (Flight, Production, Systems, or Materiel)	120	11
Inventory Control - CAS (4 people) (Adjust proportionally for each shift if element contains more personnel.)	480	44
Administration (4 people)	480	44
Conference Room (30 people)	525	49
Munitions Control (4 people) (Adjust proportionally for each shift if element contains more personnel.)	480	44
Weapons Vault	150	14
Facilities Management	120	11
Training Office	120	11
Vehicle Control NCO	120	11
Safety/QA	120	11
Training Rooms (2 for 30 people each)	900	84
Library	225	21
Break Areas	200	19
Restroom, Locker Room, Showers	500	47
Janitor Closets	50	5
Mechanical Room (verify with geographic location)	300	28
Subtotal	5,040	468
Circulation and Walls (15%)	718	67
Gross Total (MUNS Flight)	5,750	535

Table 4.3
Munitions Flight Administration Building Area Allocations



Location: Barksdale AFB, Louisiana
Command: ACC
Facility Number: 7305
Date Constructed: 1995

Design

- Lockers and showers provided
- Corrugated sheet metal and concrete block construction

Facility Overview

This facility houses several administrative functions to include munitions operations, combat ammunition system, munitions control, flight leadership, dispatch, and training. The balance of the building is used to repair, maintain, and inspect munitions trailers and related support equipment (Category Code 218-712).

Space Usage

Size (Total) 9,500 sq ft (882.58m²)
 Category Code 610-144 5,160 sq ft (479.38m²)
 Category Code 218-712 4,340 sq ft (391m²)



Exterior View

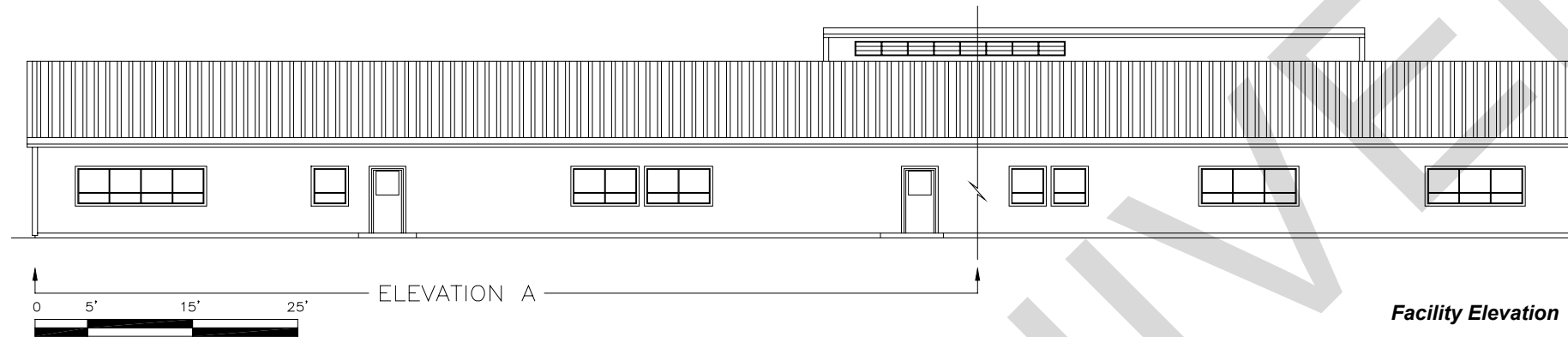

Facility Elevation

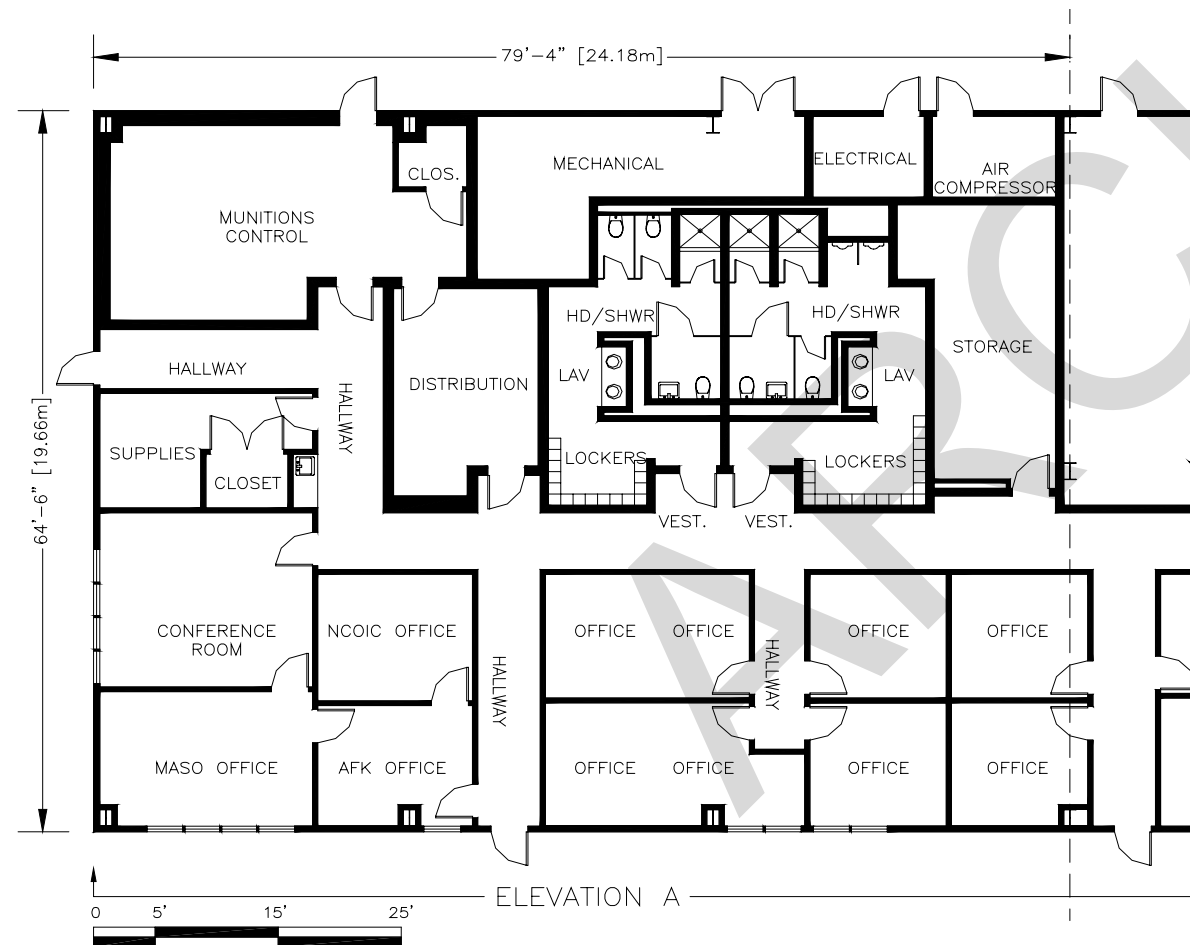

Facility Floor Plan

Category Code 610-144 Munitions Administration Facility

- Design Related to Aircraft Type**
 Aircraft Type: Bomber
 Primary Aircraft: B-52
- Stand Alone Facility**
- Consolidated Facility**
Other Uses: Aircraft Support Equipment Shop/Storage Facility/AGE Facility (218-712) – used for munitions trailer maintenance
- Single Wing**
- Multiple Wings**

Structural	<ul style="list-style-type: none"> • Facility size dependent upon mission and personnel assigned per AFH 32-1084 • Gross floor area not to exceed 162 sq ft (15.04m²) per person, plus authorized special purpose space • Provide latrine facilities to support assigned personnel • Ready/Conference/Training room sizing dependent upon student throughput and required training aids • Provide space for Munitions Control per AFI 21-201
Electrical	<ul style="list-style-type: none"> • Provide 110 VAC power and non-interruptible power supply • Provide emergency power generators to support critical and emergency services and intrusion detection • Provide UL-approved lighting • Minimum 5 foot-candles interior lighting
Fire/Safety	<ul style="list-style-type: none"> • Provide lightning and surge protection per NFPA 780 and MIL HDBK 419 • Provide grounding system per AFI 32-1065 • Provide blast-resistant windows as needed • Use non-combustible material per UFC 3-600-01 • Provide ventilation/exhaust systems per AFI 32-7040 • Provide emergency exit doors
Force Protection	<ul style="list-style-type: none"> • Security measures per AFI 31-101 • Install exterior security lighting based on local threat assessment
Equipment	<ul style="list-style-type: none"> • Provide dedicated HVAC system for Munitions Control room. Remainder of facility requires separate HVAC

- Other References:**
- AFH 32-1084 – Facilities Requirements
 - AFMAN 91-201 – Explosives Safety Standards
 - AFI 31-101 – The Physical Security Program
 - DoD 6055.9 STD – DoD Ammunition and Explosives Safety Standards

ARCHIVED

Please see the next page.

Location: Pope AFB, North Carolina
Command: AMC
Facility Number: 5003
Date Constructed: 2000

Facility Overview

This facility houses several administrative functions to include Munitions Control, flight supervision, and the accountability section.

Design

- Adequate space for the colocation of multiple functions
- Private office space for flight supervision

Space Usage

Size (Total) 3,623 sq ft (336.59m²)



Munitions Administration Building



Block Construction with Metal Roof

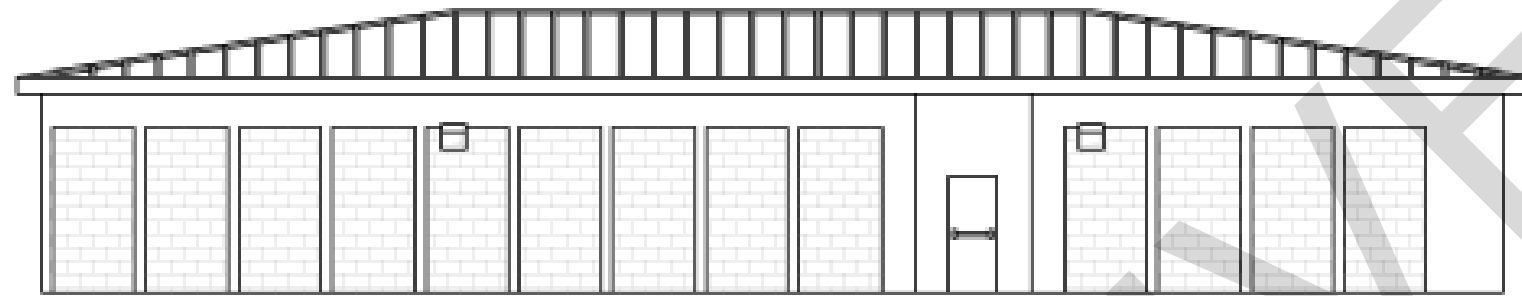

Facility Elevation (NTS)

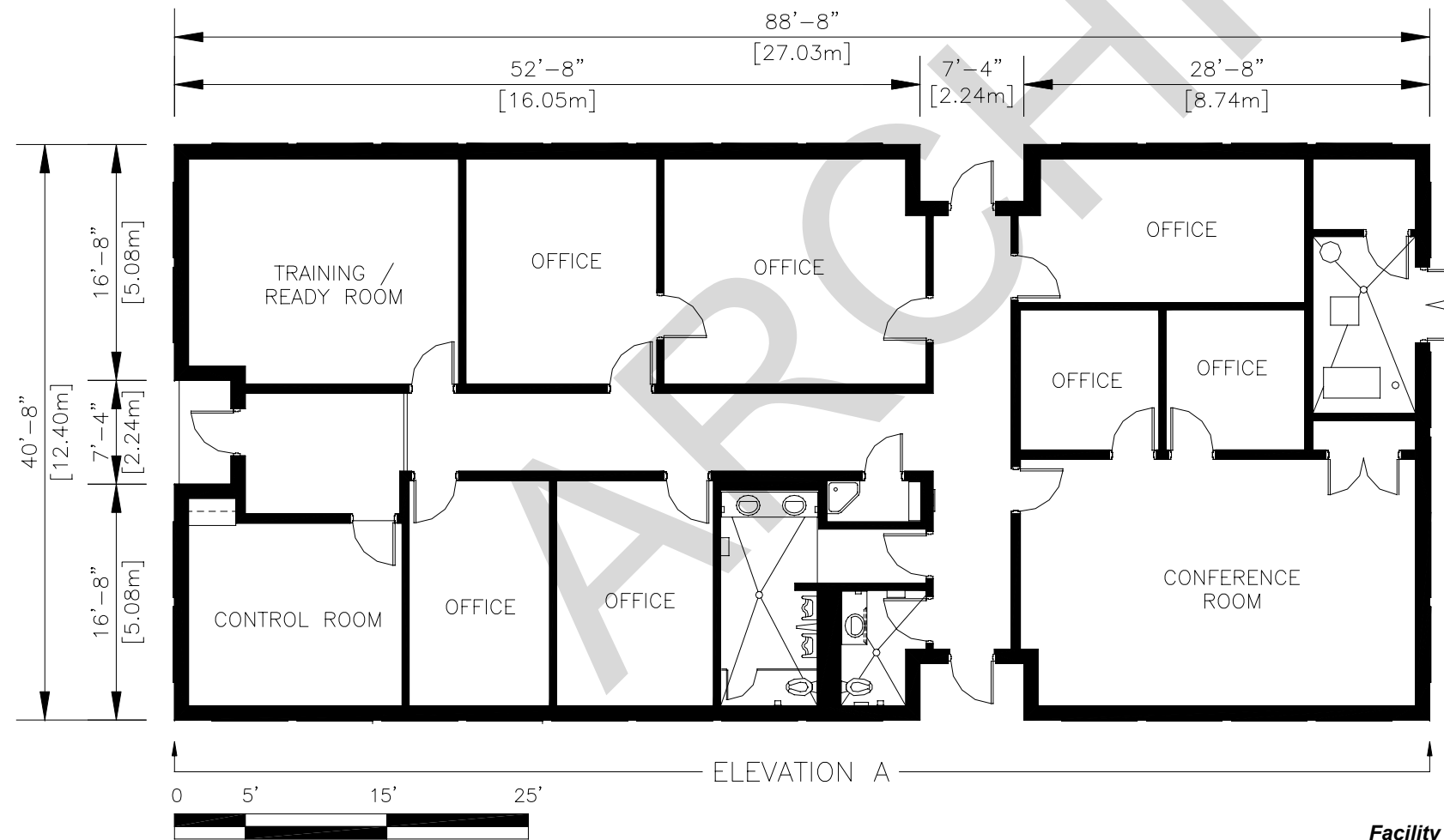

Facility Floor Plan

Category Code 610-144
Munitions Administration Facility

Design Related to Aircraft Type
 Aircraft Type: Fighter
 Primary Aircraft: A-10

Stand Alone Facility
 Consolidated Facility
 Other Uses:

Single Wing
 Multiple Wings

Structural

- Facility size dependent upon mission and personnel assigned per AFH 32-1084
- Gross floor area not to exceed 162 sq ft (15.04m²) per person, plus authorized special purpose space
- Provide latrine facilities to support assigned personnel
- Ready and/or training room sizing dependent upon student throughput and required training aids
- Provide space for Munitions Control per AFI 21-201

Electrical

- Provide 110 VAC power and non-interruptible power supply
- Provide emergency power generators to support critical and emergency services and intrusion detection
- Provide UL-approved lighting
- Minimum 5 foot-candles interior lighting

Fire/Safety

- Provide lightning and surge protection per NFPA 780 and MIL HDBK 419
- Provide grounding system per AFI 32-1065
- Provide blast-resistant windows as needed
- Use non-combustible material per UFC 3-600-01
- Provide ventilation/exhaust systems per AFI 32-7040
- Provide emergency exit doors

Force Protection

- Security measures per AFI 31-101
- Install exterior security lighting based on local threat assessment

Equipment

- Provide dedicated HVAC system for Munitions Control room. Remainder of facility requires separate HVAC

Other References:

- AFH 32-1084 – Facilities Requirements
- AFMAN 91-201 – Explosives Safety Standards
- AFI 31-101 – The Physical Security Program
- DoD 6055.9 STD – DoD Ammunition and Explosives Safety Standards

ARCHIVED

Please see the next page.

Location: Whiteman AFB, Missouri
Command: ACC
Facility Number: 4076
Date Constructed: 2002

Design

- Adequate space for the colocation of multiple functions
- Private office space for command element
- Large conference room



Munitions Administration Building



Common Area

Facility Overview

This facility houses several administrative functions to include the munitions squadron command element, munitions control, flight leadership, the munitions accountable systems officer, and the munitions accountability section.

Space Usage
 Size (Total) 9,684 sq ft (900 m)

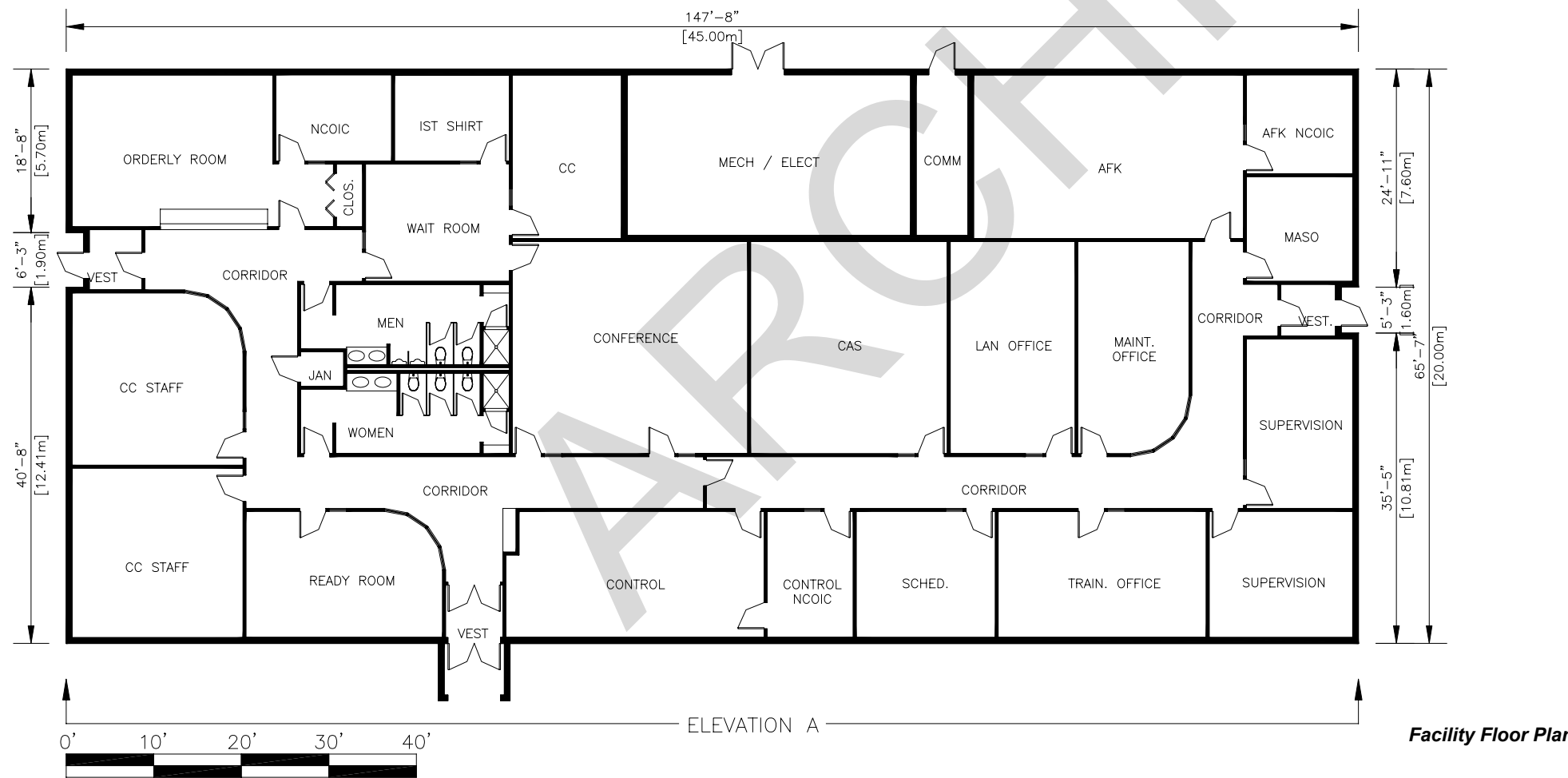
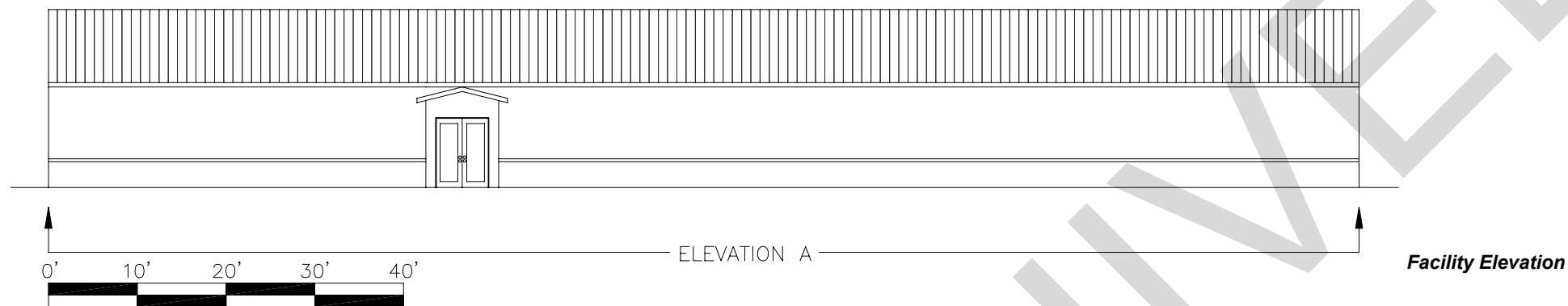

Category Code 610-144
Munitions Administration Facility

Design Related to Aircraft Type
 Aircraft Type: Bomber
 Primary Aircraft: B-2

Stand Alone Facility
 Consolidated Facility
Other Uses:

Single Wing
 Multiple Wings

Structural	<ul style="list-style-type: none"> • Facility size dependent upon mission and personnel assigned per AFH 32-1084 • Gross floor area not to exceed 162 sq ft (15.04m²) per person, plus authorized special purpose space • Provide latrine facilities to support assigned personnel • Ready and/or training room sizing dependent upon student throughput and required training aids • Provide space for Munitions Control per AFI 21-201
Electrical	<ul style="list-style-type: none"> • Provide 110 VAC power and non-interruptible power supply • Provide emergency power generators to support critical and emergency services and intrusion detection • Provide UL-approved lighting • Minimum 5 foot-candles interior lighting
Fire/Safety	<ul style="list-style-type: none"> • Provide lightning and surge protection per NFPA 780, MIL HDBK 419, and AFMAN 91-201 • Provide grounding system per AFI 32-1065 • Provide blast-resistant windows as needed • Use non-combustible material per UFC 3-600-01 • Provide ventilation/exhaust systems per AFI 32-7040 • Provide emergency exit doors per AFMAN 91-201
Force Protection	<ul style="list-style-type: none"> • Security measures per AFI 31-101 • Install exterior security lighting based on local threat assessment
Equipment	<ul style="list-style-type: none"> • Provide dedicated HVAC system for Munitions Control room. Remainder of facility requires separate HVAC

Other References:

- AFH 32-1084 – *Facilities Requirements*
- AFMAN 91-201 – *Explosives Safety Standards*
- AFI 31-101 – *The Physical Security Program*
- DoD 6055.9 STD – *DoD Ammunition and Explosives Safety Standards*

ARCHIVED

Please see the next page.



TABLE OF CONTENTS

CHAPTER 5: REFERENCES, FORMS, ABBREVIATIONS AND ACRONYMS, AND TERMS

5.1 REFERENCES 5-1

 5.1.1 United States Government 5-1

 5.1.2 Department of the Air Force 5-3

 5.1.3 Department of the Army 5-6

 5.1.4 Non-Government 5-6

5.2 FORMS 5-7

 5.2.1 Department of Defense 5-7

 5.2.2 Department of the Air Force 5-7

5.3 ABBREVIATIONS AND ACRONYMS 5-7

5.4 TERMS 5-11

ARCHIVED





LIST OF FIGURES

CHAPTER 5: REFERENCES, FORMS, ABBREVIATIONS AND ACRONYMS AND TERMS

FIGURE 5.1 : Typical Barricade Stack Relationship.....15

ARCHIVED





CHAPTER 5

REFERENCES, FORMS, ABBREVIATIONS AND ACRONYMS, AND TERMS

5.1 References

5.1.1 United States Government

5.1.1.1 Miscellaneous

Americans with Disabilities Act Accessibility Guidelines (ADAAG) Web Site (<http://www.access-board.gov/adaag/html/adaag.htm>)

Energy Star Web Site (<http://www.energystar.gov/>)

Environment Protection Agency (EPA) Web Site (<http://www.epa.gov/cpg/products/>)

Occupational Safety and Health Administration (OSHA) Web Site (<http://www.osha.gov/>)

Title 10, Code of Federal Regulations (CFR) 435, Chapter II, *Energy* (http://www.access.gpo.gov/nara/cfr/waisidx_02/10cfrv2_02.html)

Title 41 CFR, *Federal Property Management Regulation* (http://www.access.gpo.gov/nara/cfr/waisidx_02/41cfrv2_02.html)

Uniform Federal Accessibility Standard (UFAS) Web Site (<http://www.access-board.gov/ufas/ufas-html/ufas.htm>)

5.1.1.2 Department of Defense (DoD)

DoD Instruction (I) 2000.16, *DoD Antiterrorism Standards* (http://www.dtic.mil/whs/directives/corres/pdf/i200016_061401/i200016p.pdf)

DoD 4500.9-Regulation, *Defense Transportation Regulation (DTR)* Parts I-VI. (<http://www.transcom.mil/j5/pt/dtr-part-2-toc.pdf>)

DoD 5100.76-M Directive, *Physical Security of Sensitive Conventional Arms, Ammunition, and Explosives* (<http://www.cfisac.org/FSO%20Library/Misc/p510076m.pdf>)

DoD 6055.9-Standard, *DoD Ammunition and Explosives Safety Standards*. (http://www.dtic.mil/whs/directives/corres/pdf/60559std_0799/p60559s.pdf)

DoD *Energy Manager's Handbook* (<http://www.afcesa.af.mil/Directorate/CES/Mechanical/Energy>)



Department of Defense Explosives Safety Board (DDESB) Technical Paper 15 (TP-15), *Approved Protective Construction (Version 1.0)*, 02 Feb 2002.

OSD Pricing Guide

(<http://www.sam.usace.army.mil/en/cost/misc/OSDCOSTS/Osd1.xls>)

Military Handbook (MIL HDBK)

419A, *Grounding, Bonding, and Shielding for Equipment and Facilities*, 29 Dec 1987.

1013/1A, *Design Guidelines for Physical Security of Facilities*, 15 Dec 1993. (<http://www.dodssp.daps.mil/>)

1165, *Water Conservation*, 07 April 1997.

1190, *Facility Planning and Design Guide*, 01 Sept 1987.

Unified Facility Criteria (UFC)

UFC 3-120-01, *Air Force Sign Standard*, 06 Feb 2003.

UFC 3-190-04FA, *Design: Roofing And Waterproofing*, 17 Nov 2003

UFC 3-210-01A, *Design: Area Planning, Site Planning, and Design*, 01 Jul 2003

UFC 3-230-17FA, *Design: Drainage for Areas Other than Airfields*, 01 Jul 2003

UFC 3-230-18FA, *Design: General Provisions and Geometric Design for Roads, Streets, Walks, and Open Storage Areas*, 01 Jul 2003

UFC 3-250-01FA, *Design: Pavement Design for Roads, Streets, Walks and Open Storage Areas*, 01 Jul 2003

UFC 3-260-01, *Airfield and Heliport Planning and Design*, 01 Nov 2001

UFC 3-310-01, *Design: Load Assumptions for Buildings*, 30 June 2001

UFC 3-340-01, Design (FOUO): *Design and Analysis of Hardened Structures to Conventional Weapons Effects*, 30 June 2002

UFC 3-570-02N, *Design: Electrical Engineering Cathodic Protection*, 16 Jan 2004

UFC 3-600-1, Design: *Fire Protection Engineering for Facilities*, 20 Aug 2003.

UFC 3-701-03, *DoD Facilities Pricing Guide*, Version 5, Mar 2003.

UFC 4-010-01, Design: *DoD Minimum Antiterrorism Standards for Buildings*, 31 July 2002.

UFC 4-021-01, Design and O&M: *Mass Notification System*, 18 Dec 2002



5.1.2 Department of the Air Force

Air Force Catalog (AFCAT)

21-209, Volume 1, *Ground Munitions*, 03 Oct 2002.

Air Force Handbook (AFH)

AFH 32-1084, *Facility Requirements*, 01 Sept 1996

AFH 32-1163, *Engineering Weather Data*, 01 July 2000

AFH 32-7084, *AICUZ Program Manager's Guide*, 01 Mar 1999

Air Force Instruction (AFI)

AFI 10-245, *Air Force Antiterrorism (AT) Standards*, 21 Jun 2002.

AFI 10-503, *Base Unit Beddown Program*, 29 May 2003.

AFI 21-101, *Aerospace Equipment Maintenance Management*, 01 Oct 2002

AFI 21-201, *Management and Maintenance of Non-Nuclear Munitions*, 13 Jan 2003.

AFI 31-101, *The Air Force Installation Security Program (FOUO)*, 01 Mar 2003.

AFI 32-1021, *Planning and Programming of Military Construction (MILCON) Projects*, 24 Jan 2003.

AFI 32-1032, *Planning and Programming Appropriated Funded Maintenance, Repair, and Construction Projects*, 15 Oct 2003.

AFI 32-1044, *Visual Air Navigation Systems*, 04 Mar 1994.

AFI 32-1062, *Electrical Power Plant and Generators*, 10 May 1994

AFI 32-1063, *Electrical Power Systems*, 31 Mar 1994.

AFI 32-1065, *Grounding Systems*, 01 Oct 1998.

AFI 32-7040, *Air Quality Compliance*, 09 May 1994.

AFI 32-7044, *Storage Tank Compliance*, 13 Nov 2003.

AFI 32-7062, *USAF Comprehensive Planning*, 01 Oct 1997.

AFI 32-7063, *Air Installation Compatible Use Zone Program*, 17 Apr 2002.

AFI 32-7080, *Pollution Prevention Program*, 12 May 1994.

AFI 33-104, *Base-Level Planning and Implementation*, 10 May 2001.

AFI 33-133, *Joint Technical Architecture*, 01 July 2000

AFI 36-2217, *Munitions Requirements for Aircrew Training*, 01 Nov 2000.

AFI 90-901, *Operational Risk Management*, 01 April 2000.

Air Force Joint Manual (AFJMAN)

AFJMAN 32-1048, *Railroad Track Standards*, 08 April 1991.



AFJMAN 32-1070, *Plumbing*, 31 August 1993
AFJMAN 32-1083, *Electrical Interior Code*, 30 Nov 1995.

Air Force Manual (AFM/AFMAN)

AFM 88-3 Chapter 13, *Seismic Design for Buildings*, 20 Oct 1992.
AFM 88-9, *Electrical Design, Interior Electrical System*, 01 Sept 1983.
AFMAN 32-1050(I), *Seismic Design Guideline for Upgrading Existing Buildings*, 01 Sept 1988.
AFMAN 32-1076, *Design Standards for Visual Air Navigation Facilities*, 01 Dec 1997.
AFMAN 32-1089, *Air Force Military Construction and Family Housing Economic Analysis Guide*, 01 Aug 1996.
AFMAN 32-1125(I), *Railroad Design and Rehabilitation*, 01 March 2000.
AFMAN 33-105, *Engineering and Installation Services*, 21 June 2001.
AFMAN 91-201, *Explosives Safety Standards*, 18 Oct 2001.

Air Force Pamphlet (AFPAM)

AFPAM 90-902, *Operational Risk Management Guidelines Tools*, 14 Dec 2000.
AFPAM 32-1010, *Land Use Planning*, 01 Nov 1998.

Air Force Occupational Safety and Health (AFOSH)

AFOSH 91-501, *Air Force Consolidated Occupational Safety Standard*, 16 Sept 2002.

Other Related Air Force Information Sources

Air Force Center for Environment Excellence (AFCEE) Web Site

Air Force Architectural Compatibility Guide
(<http://www.afcee.brooks.af.mil/dc/dcd/arch/ACguide/liveACG/index.htm>)

Air Force Interior Design Guidelines
(<http://www.afcee.brooks.af.mil/dc/dcd/interior/intdespu.asp>)

Guide to Green Purchasing
(<http://www.afcee.brooks.af.mil/eq/ap/gg/guide.asp>)

USAF Installation Force Protection Guide
(<http://www.afcee.brooks.af.mil/dc/dcd/arch/force.pdf>)

USAF Landscape Design Guide
(<http://www.afcee.brooks.af.mil/dc/dcd/land/ldg/index.html>)

USAF Master Landscape Construction Specifications
(<http://www.afcee.brooks.af.mil/dc/dcd/land/mstrland/mlcs.asp>)

USAF Project Manager's Guide for Design and Construction.
(<http://www.afcee.brooks.af.mil/dc/products/pmguid/pmguide.pdf>)



Air Force Civil Engineer Support Agency (AFCESA) Web Site

AFCESA's Corrosion Control Program

(<http://www.afcesa.af.mil/Directorate/CES/Mechanical/Corrosion/Corrosion.htm>)

AFCESA's Electrical Program

(<http://www.afcesa.af.mil/Directorate/CES/Mechanical/ElectrSpt/default.htm>)

AFCESA's Fire and Life Safety Engineering Program

(<http://www.afcesa.af.mil/Directorate/CES/Mechanical/FireEngr/default.htm>)

AFCESA's Fire Detection and Alarm Systems

(<http://www.afcesa.af.mil/Directorate/CES/Mechanical/FireEngr/alarm.htm>)

AFCESA's Plumbing and Natural Gas Distribution System Program

(<http://www.afcesa.af.mil/Directorate/CES/Mechanical/PlumbingGas/plumbinggas.htm>)

Historical Air Force Construction Cost Handbook

(<http://www.afcesa.af.mil/directorate/ces/civil/CostEngr/CostEngr.htm>)

Parametric Cost Engineering System (PACES)

(<http://www.afcesa.af.mil/Publications/A-Gram/2002/Agram%2002-23pdf>)

Air Force Safety Center (AFSC) Web Site (<http://afsafety.af.mil/>)

Engineering Technical Letter (ETL)

ETL 86-16, *Direct Digital Control of Heating, Ventilation, and Air Conditioning*, 09 Dec 1986.

ETL 90-6, *Electrical System Grounding, Static Grounding and Lightning Protection*, 03 Oct 1990.

ETL 94-4, *Energy Usage Criteria for Facilities in the Military Construction Program*, 19 Aug 1994.

ETL 00-5, *Seismic Design for Building and other Structures*, 05 June 2000

ETL 00-6, *Air Force Carpet Standard*, 11 May 2000.

ETL 01-1, *Reliability & Maintainability Design Checklist*, 11 Oct 2001.

ETL 02-12, *Communication and Information Systems Criteria for Air Force Facilities*, 27 June 2002.

ETL 1110-3-394, *Aircraft Characteristics for Airfield-Heliport Design and Evaluations*, 27 Sept 1991.

Air Force Technical Order (TO)

TO 42A2-1-4, *Storage Control of Organic Coating Material (Paints and Allied Materials)*
(<http://www.pdsm.wpafb.af.mil/>)

OO-ALC Weapons Safety Home Page

(<http://www.hill.af.mil/safety/weapframe.htm>)



5.1.3

Department of the Army

Technical Instruction (TI) 809-4, *Seismic Design for Buildings*, 31 Dec 1998. (<http://www.hnd.usace.army.mil/techinfo/ti.htm>)

Technical Manual (TM) 5-811, *Electric Power Supply and Distribution Series*, 25 Feb 1991. (<http://www.usace.army.mil/publications/armytm/>)

TM 5-1300/AFR 88-22, *Structures to Resist the Effects of Accidental Explosives*, 19 Nov 1990.

5.1.4

Non-Government

American National Standards Institute (ANSI), Safety Code A156.3, Building Exits Web Site (<http://www.ansi.org/>)

American Railway Engineering and Maintenance-of-Way Association (AREMA) Web Site (<http://www.arena.org/>)

American Society of Heating, Refrigerating and Air-Conditioning Engineers (ASHRAE) Standard 62, Ventilation for Acceptable Indoor Air Quality Web Site (<http://www.ashrae.org/>)

American Water Works Association (AWWA) Standard C502, Dry-Barrel Fire Hydrants Web Site (<http://www.awwa.org/>)

Assessment System for Hazard Surveys (ASHS) Web Site (<http://www.ashs.isa.com/>)

Institute of Electrical and Electronic Engineers (IEEE) IAS P1100, Emerald Book Web Site (<http://www.iesna.org/>)

Illuminating Engineering Society's (IES) Illuminance Selection Procedures Web Site (<http://www.iesna.org/>)

IES Lighting Handbook Web Site (<http://www.iesna.org/>)

International Association of Plumbing and Mechanical Officials (IAPMO) Web Site (<http://www.iapmo.org/iapmo/publications.html>)

International Building Code (IBC) Web Site (<http://www.iccsafe.org/index.html>)

Leadership in Energy and Environmental Design (LEED) Web Site (http://usgbc.org/leed/leed_main.asp)

Lightning Protection Institute (LPI) Web Site (<http://www.lightning.org/>)

National Fire Protection Association (NFPA) Web Site (<http://www.nfpa.org/catalog/home/index.asp>)

NFPA 10, *Standards for Portable Fire Extinguisher*, 2002.

NFPA 13, *Installation of Sprinkler Systems*, 2002.

NFPA 14, *Installation of Standpipe and Hose Systems*, 2003.

NFPA 30, *Flammable and Combustible Liquids Code*, 2003.



NFPA 70, *National Electric Code*, 2002.

NFPA 72, *National Fire Alarm Code*, 2002.

NFPA 80, *Standards for Fire Doors and Windows*, 1999.

NFPA 101, *Life Safety Code*, 2003.

NFPA 780, *Standards for the Installation of Lightning Protection Systems*, 2000.

National Institute of Building Sciences Web Site (<http://www.nibs.org/>)

Underwriters Laboratories (UL) Web Site (<http://www.ul.com/>)

U.S. Green Building Council (USGBC) Web Site (<http://usgbc.org/>)

5.2 Forms

5.2.1

Department Of Defense

DD Form 1391, FY ____ **Military Construction Project Data**

5.2.2

Department of the Air Force

AF Form 332, **BCE Work Request**

AF Form 813, **Request for Environmental Impact Analysis**

AF Form 943, **Explosives Safety Site Plan/Waiver/Exemption**

5.3 Abbreviations and Acronyms

A-E	Architecture-Engineering
AA&E	Arms, Ammunition, and Explosives
ACC	Air Combat Command
ADAAG	Americans with Disabilities Act Accessibility Guidelines
AFCAT	Air Force Catalog
AFCEE	Air Force Center for Environmental Excellence
AFCESA	Air Force Civil Engineer Support Agency
AFH	Air Force Handbook
AFI	Air Force Instruction
AFJMAN	Air Force Joint Manual
AFM	Air Force Manual (old publications architecture)
AFMAN	Air Force Manual (new publications architecture)
AFMC	Air Force Materiel Command
AFOSH	Air Force Occupational Safety and Health
AFPAM	Air Force Pamphlet



AFR	Air Force Regulation (old publications architecture)
AFRC	Air Force Reserve Command
AFSC	Air Force Safety Center
AGE	Aerospace Ground Equipment
AICUZ	Air Installation Compatible Use Zone
AME	Alternate Mission Equipment
ANG	Air National Guard
ANSI	American National Standards Institute
APOD	Aerial Ports of Debarkation
APOE	Aerial Ports of Embarkation
ASHRAE	American Society of Heating, Refrigeration, and Air Conditioning Engineers
ASHS	Assessment System for Hazard Surveys
AT/FP	Anti-Terrorism/Force Protection
BCE	Base Civil Engineer
CAS	Combat Ammunition System
Cat Code	Real Property Category Code
CBU	Cluster Bomb Unit
CE	Civil Engineer
CFR	Code of Federal Regulations
CONUS	Continental United States
DD	Department of Defense (used for forms)
DDC	Direct Digital Control
DDESB	Department of Defense Explosives Safety Board
DoD	Department of Defense
ECM	Earth-covered Magazine
EED	Electro-explosive Device
EMR	Electromagnetic Radiation
EPA	Environmental Protection Agency
ES	Exposed Site
ESP	Explosives Site Plan
ETL	Engineering Technical Letter
EUCOM	European Command
FOD	Foreign Object Damage
FOUO	For Official Use Only



ft	Feet or Foot (measurement)
FPCON	Force Protection Condition
GOV	Government Owned Vehicle
HAMS	Holding Area Munitions
HC/D	Hazard Class/Division
HDBK	Handbook
HID	High Intensity Discharge
HVAC	Heating, Ventilation, and Air Conditioning
Hz	Hertz
IAPMO	International Association of Plumbing and Mechanical Officials
IAW	In Accordance With
IBC	International Building Code
IBD	Inhabited Building Distance
IDE	Intrusion Detection Equipment
IDS	Intrusion Detection System
IEEE	Institute of Electrical and Electronic Engineers
IES	Illuminating Engineering Society
IL	Intraline
IM	Intermagazine
IMF	Integrated Maintenance Facility
in	Inch
IPC	International Plumbing Code
ISO	International Organization for Standardization
JTA	Joint Technical Architecture
K	Thousands
kg	Kilogram
km	Kilometer
kPa	Kilo Pascals
lb	Pound
LCC	Life Cycle Costs
LEED	Leadership in Energy and Environmental Design
LPI	Lightning Protection Institute
LPS	Lightning Protection System
m	Meter



m ²	Square Meter
m ³	Cubic Meter
MAC	Munitions Assembly Conveyor
MAJCOM	Major Command
MASO	Munitions Accountable Systems Officer
MCE	Maximum Credible Event
MER	Multiple Ejector Racks
MIL	Military
MILCON	Military Construction
MILVAN	Military Van
mm	Millimeter
MMHE	Munitions Materiel Handling Equipment
MSA	Munitions Storage Area
MSM	Munitions Storage Module
MUNS	Munitions Squadron
MXG	Maintenance Group
NATO	North Atlantic Treaty Organization
NEC	National Electric Code
NEW	Net Explosives Weight
NFPA	National Fire Protection Agency
O&M	Operations and Maintenance
OCONUS	Overseas
OPR	Office of Primary Responsibility
OSD	Office of the Secretary of Defense
OSHA	Occupational Safety and Health Administration
PAA	Primary Assigned Aircraft
PACES	Parametric Cost Engineering System
PACAF	Pacific Air Forces
PACOM	Pacific Command
PES	Potential Explosion Site
PM	Program Manager
PMO	Program Management Office
POC	Point of Contact
POL	Petroleum, Oil, Lubricant



POV	Privately Owned Vehicle
psig	Pounds Per Square Inch Gauge
Q-D	Quantity-Distance
R&M	Reliability and Maintainability
SEW	Office Symbol for the Weapons Safety Function
sf	Square Foot (or Feet)
STD	Standard
sy	Square Yards
TCTO	Time Compliance Technical Order
TI	Technical Instruction
TM	Technical Manual
TNT	Trinitrotoluene
TO	Technical Order
TOFC	Trailer on Flat Cars
TP	Technical Paper
UFAS	Uniform Federal Accessibility Standard
UFC	Unified Facilities Criteria
UL	Underwriters Laboratories
UPS	Uninterrupted Power Supply
USAF	United States Air Force
USGBC	U.S. Green Building Council
VAC	Volts Alternating Current
WRM	War Reserve Materiel
WSM	Weapons Safety Manager
yd	Yards

5.4 Terms

Assessment System for Hazard Surveys (ASHS). It is a computer-aided tool that was first created to support the Air Force Explosives Hazard Reduction program. The primary function of ASHS II is to analyze an existing explosives storage or operational situation and identify the quantity-distance problems.

Barricade. An intervening barrier (natural or artificial) of such size, type, and construction as to limit the effect of low angle, high velocity fragments.



Cardinal Principle of Explosives Safety. Basic explosives safety principle is to expose the minimum number of people to the minimum amount of munitions for the minimum amount of time.

Charrette. An intensive conceptual design session usually held at the functional user site. It may last several days and is attended by the functional user, architecture-engineering (A-E), construction agent, the project management team, and sometimes by MAJCOM representatives.

Compatibility. Explosives are considered compatible if they may be stored or transported together without significantly increasing the probability of a mishap or, for a given quantity, the magnitude of the effects of a mishap.

Concurrent Operations. Two or more explosives operations within a single facility or location.

Deviation. Written authorization which allows a specific departure from the rules of AFMAN 91-201 other than quantity-distance criteria.

DoD Explosives Safety Board (DDESB). DoD organization charged with promulgating explosives safety policy and standards, and with reporting on the effectiveness of the implementation of such policy and standards.

Electro-explosive Device (EED). An explosive or pyrotechnic component initiated by the application of electricity.

Electromagnetic Radiation (EMR). Radiation made up of oscillating electric and magnetic fields and propagated with the speed of light. Includes gamma radiation, X-rays, ultraviolet, visible, and infrared radiation, and radar and radio waves.

Energy Star. Energy Star is a government-backed program helping businesses and individuals protect the environment through superior energy efficiency products.

Exception. An inclusive term for any departure from the requirements of AFMAN 91-201.

Exemption. A relatively long-term departure from a mandatory quantity-distance requirement standard of AFMAN 91-201.

Explosive. A substance or mixture of substances that under external influences, is capable of rapidly releasing energy in the form of gases and heat.

Explosives Clear Zone. The area around a Potential Explosion Site (PES) that is determined by the required inhabited building distance (IBD) separation. The IBD separation will be based on the sited, waived, exempted, or actual explosives limits of the PES site, whichever is greatest.

Explosives Site Plan (ESP). A package consisting of all the necessary information to assess compliance with explosives safety standards for an explosives storage or operating location and their impacted exposed sites. Once approved, the ESP identifies storage and operating limitations, and



provides a tool for managing the risks associated with the storage or operating location.

Exposed Site (ES). Any permanent facility, utility, Petroleum, Oil, and Lubricant (POL), site storage, at risk from either blast or fire effects of a Potential Explosion Site (PES). An ES may or may not contain explosives.

Field Office. Any office adjacent to or within an explosives area in which operational administrative functions pertaining to explosives are performed. Quantity-Distance criteria is not applied to the personnel in the offices of this potential explosion site who perform maintenance in the bays or provide first-level supervisory guidance to these workers.

Inhabited Building Distance (IBD). The minimum allowable distance between an inhabited building and a potential explosion site.

Intermagazine Distance (IM). The minimum distance allowed between two explosives locations. This distance is expected to prevent simultaneous detonation.

Inert. Contains no explosives, active chemicals, or pyrotechnics, but is not necessarily noncombustible.

Intraline Distance (IL). The minimum distance allowed between any two operating locations or other designated exposures. This distance is expected to prevent propagation.

License. Formal permission to store explosives or munitions outside the sited munitions storage area.

Maximum Credible Event (MCE). An MCE is defined as the largest quantity of explosives expected to explode at one time when an item in a stack or group of items is initiated or when explosives are stored at less than intermagazine distance apart.

MILCON COACH. An AFCEE-developed software-based technical tool for the Air Force construction community. This tool is intended to improve Air Force Project Managers' (PM) productivity and efficiency. MILCON Coach's goal is to harvest needed knowledge from PMs over time, store it electronically, and make it available to other PMs when it is needed. PMs can use the "lessons learned" feature to record useful advice for distribution in future program updates.

Net Explosives Weight (NEW). The total quantity, expressed in pounds, of explosives material or pyrotechnics in each item or round.

Operating Location. A building, facility, or site in which operations pertaining to the manufacturing, processing, handling, or assembling of ammunition or explosives is done.

Outsized. Military transportation term defining wide load, or something that extends beyond standard vehicle or pallet width.

Parametric Cost Engineering System (PACES). PACES is an Air Force integrated personal computer-based parametric budgeting and cost estimating system developed for military construction application. Parametric cost estimates can be prepared for new facility construction,



renovation, and life cycle costs. The parametric approach differs from traditional cost estimating methods by allowing the user to input a minimum amount of information to create a cost estimate; with model default quantities based on similar projects and experienced architectural and engineering assumptions. Pre-defined and documented engineering relationships link the primary parameters to detailed design assumptions and associated engineering quantities.

Potential Explosion Site (PES). A location or facility that contains or is expected to contain explosives.

Quantity-Distance (Q-D). The quantity of explosives material and distance separation relationships that provide definitive types of protection. These relationships are based on the level of risk considered acceptable for each stipulated exposure and are tabulated in the Q-D tables in AFMAN 91-201. Separation distances are not absolute safe distances but are relative protective or safe distances.

Real Property Category Code. Two 3-digit numbers separated by a hyphen that depict a description of a particular real property asset (i.e., complete facility or part of infrastructure). The category code describes the real property's function. It is essential the category codes are accurate to ensure the proper funding for repairs and/or replacement.

Risk Assessment. A method of determining and documenting hazards which may be present and controls for mitigating or eliminating those hazards.

Substantial Dividing Walls. Walls normally used between bays to prevent propagation of an explosion from one bay to another. They provide limited personnel protection. They are made of reinforced concrete at least 12 in. thick (304.8mm).

Two-Degree Rule. Properly constructed or natural barricades eliminate the risk of propagating explosions caused by low-angle, high-speed fragments and should prevent simultaneous detonation of an explosion. Barricade elevation is effective when a straight line, drawn from the top of the far edge of the stack edge away from the barricade at a two degree angle above the horizontal must pass through the 3-feet (915mm) width of the crest (berm) of the barricade. (See Figure 5.1 on next page)

Waiver. Written authority for a specific short-term (should be corrected within 5 years) departure from a mandatory quantity-distance requirement in AFMAN 91-201.



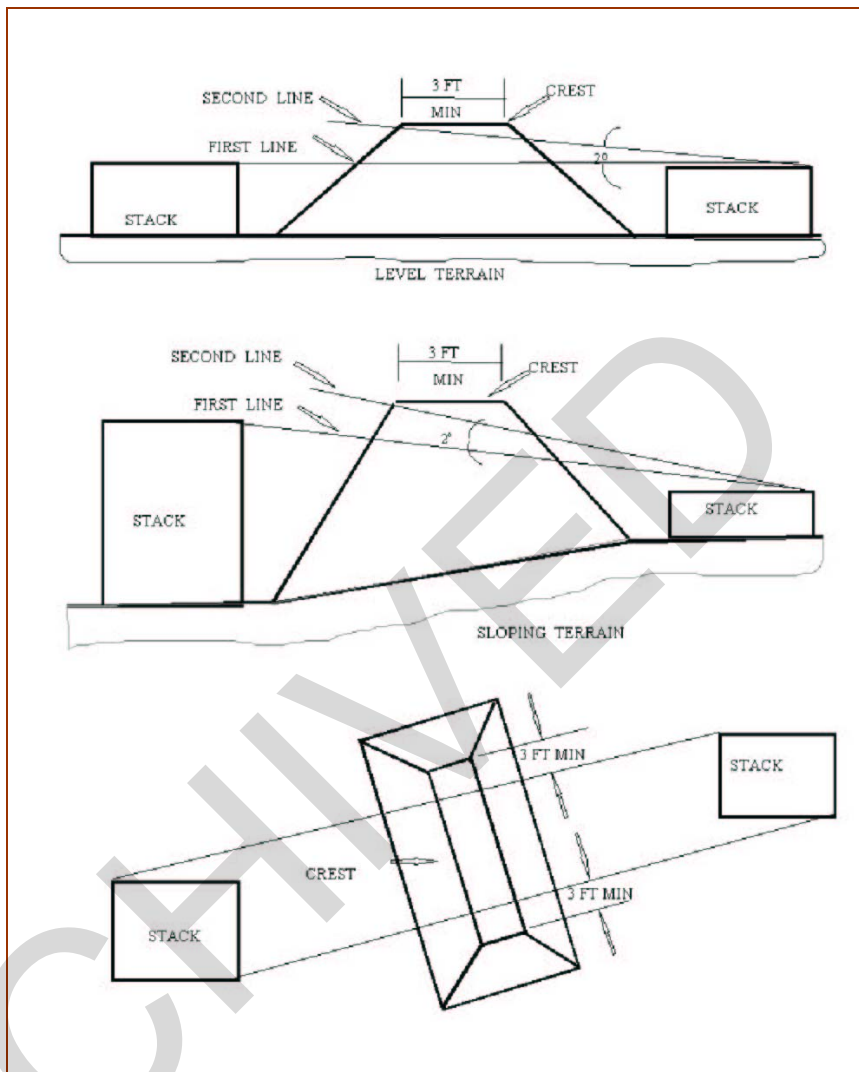

Figure 5.1:
Typical Barricade Stack Relationship





URS

7720 North 16th Street, Suite 100, Phoenix, Arizona 85020 Tel.: 602.371.1100

